

# RelaiXed – Assembly and Use Guide

The RelaiXed is a high-end pre-amplifier designed for balanced audio connections with IR remote control. The RelaiXed is a DIY design and has been published initially in the Dutch 'Elektor Audio Special' DIY magazine on December 7<sup>th</sup>, 2007. The design and publication are the result of a cooperation between Sander Sassen and me, Jos van Eijndhoven. This document is part of the design documentation on the website at: <http://jos.vaneijndhoven.net/relaixed>

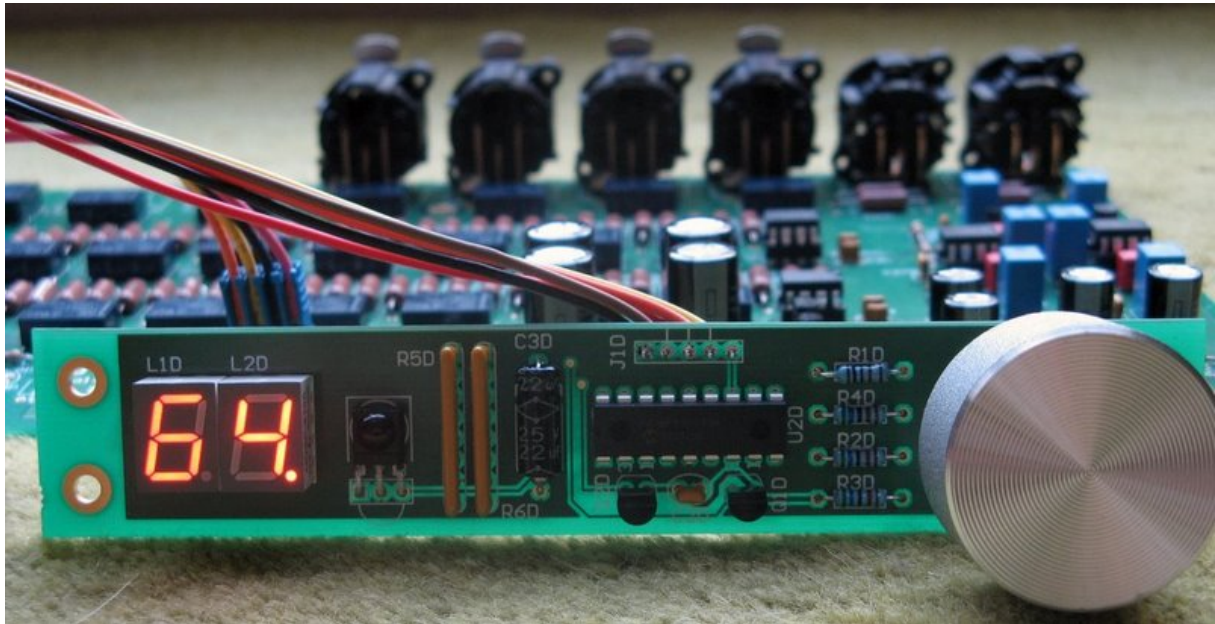

Document version Jan 26, 2009  
(Updated to reflect the behavior of the new Jan'09 firmware revision.)

The design of this preamp is protected under copyright, 2007. It is freely available for DIY home/hobby use. It is not allowed to use (parts of) the design for commercial use without explicit permission of the author.

## Acknowledgments

The RelaiXed preamplifier would never have been created if Sander Sassen had not stimulated me to launch this project. He commented on my early schematics, and deserves the credits for the publication in the Elector magazine. Guido Tent gave me the first opportunity for listening to the RelaiXed prototype as part of an audio system of astounding quality, giving valuable feedback on its sonic behavior. I thank Cees van Valkenburg for a painstaking rewrite of this document, transforming my original scribbling into real English language.

## Characteristics

The design of this preamp is based on an earlier design for a passive input, select and volume control for plain stereo (unbalanced) signals. The passive design was successfully applied in high-end audio systems of quite some DIY enthusiasts, mostly in the Netherlands. Its simple, passive design results in a very clean and open sound, although the inherent high output resistance limits its applicability (see <http://jos.vaneijndhoven.net/switchr/design.html>). To overcome such limitations the RelaiXed has been developed.

This preamplifier is designed to accept balanced stereo signals, usually fed through XLR connectors. This complements a number of power-amplifiers that recently appeared in the DIY world preferring balanced input signals, such as the Extrema (<http://www.hardwareanalysis.com>) and commercial designs such as the Class-D modules from <http://hypex.nl>. The RelaiXed maintains the 6-stage relay-based attenuator from the earlier passive design plus its IR remote control. Along with doubling for balanced operation, the major modification is the high-quality op-amp-based output stage with per channel separated power-supplies.

The preamp features infra-red remote functions as to volume control, input channel selection, 'mute', and -optionally- power on/off. Volume control and channel selection are executed through small-signal relays. Two series of six relays implement a 4-channel (balanced stereo) 64-step logarithmic attenuator. Such a combination of high-quality contact relays with prime quality resistors leads to superior volume control, audibly far better than conventional potentiometers employing a sliding contact over a resistive layer. The sealed relays maintain their contact quality over a practically unlimited time span.

The main ('relay') PCB carries the input selection relays, the attenuator, the active output stage, the power supply stabilization section and part of the digital control. With its on-board XLR connectors, this PCB must be mounted close to the chassis rear panel. An additional small 'display' PCB is designed for front panel mounting, and accommodates the IR-reception, a 2-digit 7-segment display for visual feedback, and an optional manual control switch. Note that no audio signals are routed to the front panel. The gold-plated PCB not only looks strikingly beautiful but is also very easy to solder, and some people believe that such gold finish positively affects sound quality.

The preamp has a volume range from 00 up to and including 64. Volume levels 01 to 64 span a dynamic range of 63dB with 1.0 dB steps. A 63-dB range in power corresponds to a range of for instance 0.1mW to 200W, depending on your power amplifier. Volume level 00 disables all input signals giving zero output.

The RelaiXed has been designed to provide a balanced audio path from input to output. However, many users will also want to connect conventional 'single ended' (cinch-based) input signals. The preamp supports that, by converting such inputs to balanced output signals. Six selectable inputs are provided. The design allows two configurations: 4 single-ended input channels and 2 balanced input channels, or 3 single-ended and 3 balanced ones. The RelaiXed has no dedicated IR remote control unit but meets different existing remote control protocols: the Philips RC5 and RC6 as well as the Sony SIRC protocol. As also other brands meet these protocols, it should be easy to find a compatible control device. In fact, any 'generic' IR remote control unit will be fine. Within these protocols, there is still much freedom to link specific buttons to functions. To meet such flexibility the preamp can 'learn' button code signals. This is accomplished through a set-up procedure explained later in this document.

## Comments to the schematics

### The attenuator:

The attenuator comprises 64 volume settings, created with a series of 6 stages. For each of 4 independent channels each stage has one switch and 2 resistors. Each switch has 2 states (relay on or off), so for each channel there are  $2 \times 2 \times 2 \times 2 \times 2 \times 2 = 64$  volume positions. The resistor values are selected such that the first stage gives 1.0 or 0 dB attenuation, the 2<sup>nd</sup> stage 2.0 or 0 dB, the 3<sup>rd</sup> 4.0 dB, ... , the 6<sup>th</sup> gives 32 or 0 dB attenuation. The switch positions and resistor values are selected such that the different stages do not influence each others attenuation. If you are interested, you can check more details regarding this topic on my other web pages at <http://jos.vaneijndhoven.net/switchr/switchdesign.html> and <http://jos.vaneijndhoven.net/switchr/switchprog.html>.

The clicking of the small relays results in a clear mechanical sound. If you do not want to hear that, you should not build this preamp. The design minimizes clicking noise in the audio signal by a) the attenuator circuitry, and b) optimized firmware timing in the relay control. Unfortunately, some parasitic capacitive coupling remains from the relay coils into the audio signal. Thanks to the symmetrical schematics, this signal does not appear as differential voltage in the balanced output signal. Although total silence cannot be guaranteed, clicks in the output signal do not seem to be noticeable.

### The power supply:

The power supply rectifiers are of the schottky type. This is because schottky rectifiers lack the 'reverse recovery time' effect common for 'normal' silicon p-n diodes. As a result, they generate less high-frequency switching noise. The remaining 'switching noise' is caused by the parasitic output inductance of the transformer, in combination with the fast switching-off of the diodes. These high-frequency noise components are filtered and dampened by the small 10nF and 47nF capacitors and 100 ohm series resistors. These resistors provide damping to suppress any 'ringing', and these small capacitors short-circuit this high-frequency noise to ground. I believe this configuration is superior to other designs where small capacitors over the diodes are used, allowing these high-frequency components to enter the power supply capacitor.

Regarding the analog power supplies, a positive and negative reference voltage is generated by a 'TL431' shunt regulator. R7P versus R12P (and R16P versus R13P) fix the reference voltage to 16.5 Volt. The JFETs coupled in series significantly improve the suppression of power supply hum (over having a series resistor only. The 100 $\mu$ F elco's further improve hum suppression, but are in fact included to suppress the noise generated by the voltage references. The voltage references are followed by two times two buffer-stages to deliver sufficient output current, separate for each audio opamp supply pin. The output current is delivered by the BC337 and BC327 transistors. To accurately maintain the output voltage with a low output impedance over a very wide frequency range these transistors are controlled in a stabilization loop by the op-amps.

A few measurements underline the quality of the power supply stabilization in the current design. For comparison the output of the LM7812 regulator on this same PCB is measured:

<b><i>Measured parameters</i></b>	<b><i>Discrete 16V audio supply stabilization</i></b>	<b><i>LM7812</i></b>
Output white noise density, in dBV/sqrt(Hz), measured at 1kHz	-170	-125
Same in nV/sqrt(Hz)	3	560
Output 100Hz hum, in dBV	-152	-85
Same in $\mu$ V	0.025	56
Output resistance at 1kHz	0.7m $\Omega$	20m $\Omega$
Same at 10kHz/100kHz/1MHz	7m $\Omega$ /73m $\Omega$ /230m $\Omega$	200m $\Omega$ /1 $\Omega$ /1 $\Omega$

**Some measurements on the audio signals:**

The audio signal bandwidth is from DC to 700kHz. On a 100kHz(!) square wave signal, the preamp delivers a smooth output signal without overshoot:



(This picture is a photo from my oscilloscope, showing input and output signal as green curve on black background, inserted here with inverted colors.)

At maximum volume (64) the input-to-output gain in differential mode is 3.1x, or 9.8dB. On a single-ended (cinch) input the gain 6.2x (single 1V in, 2x 3.1V out), or 15.6dB.

[An adjustment to obtain at maximum volume an exact unit gain (1.0x) is indicated in Appendix 1.]

Channel separation for cinch inputs (R-input driven, L-input grounded) is measured at 113dB at 1kHz, and 102dB at 10kHz.

With my hobby equipment I cannot measure the distortion in the audio output. The LM4562 op-amp data sheet specifies a 0.00003% distortion. Below is a spectrum analyzer picture of the output signal, measured with a 750Hz sine wave. This picture suggests a distortion level of -100dB, which is 0.001%. However, when I directly measure the preamp input signal, I obtain about the same picture (with the same noise floor), which means that the distortion is part of the input signal applied and/or part of the measurement device: my Creative Audigy-2 PC sound card.

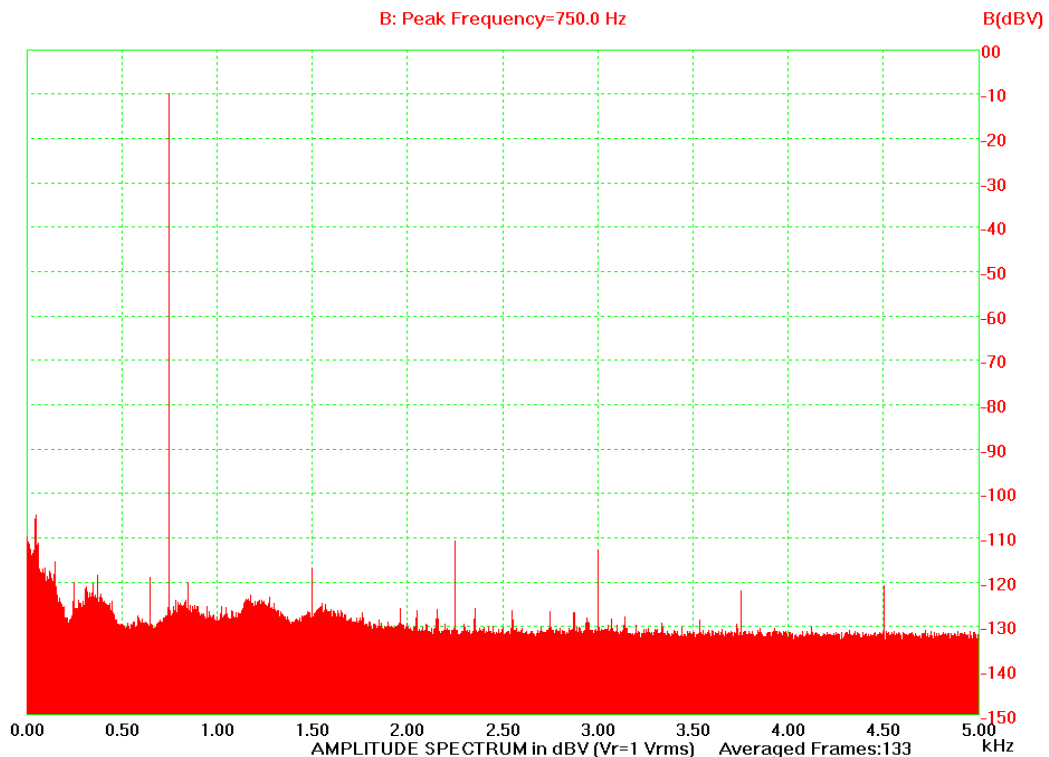

## Collecting the preamp components

A separate document is provided with a component table, that lists in detail component types, their PCB footprint, the component count to be ordered, and -as extra service- their part numbers in three electronic web shops.

As one can obtain most components easily from these shops, I intend to provide help only to acquire some specific parts. If needed you can send me an email request for:

- a) The PCB itself,
- b) The two micro controllers preprogrammed with their firmware,
- c) The LM4562 dual op-amps in DIL8 housing,
- d) A set of high-quality Dale RN60-series resistors for the resistors in the audio path.

Some comments on these components:

The LM4562 is a remarkable new op-amp, that really pushes the state-of-the-art for high-quality audio opamps. Its excellent sound is at least partially caused by its high bandwidth: the unity-gain bandwidth is about 55 MHz. As a result a high effective feedback ratio through the complete audio frequency band is attained, leading to very low distortion figures and very low phase/timing errors. Furthermore an impressively low voltage noise is specified. The high bandwidth and low noise result in a relatively high quiescent current, making them warm to touch. The high bandwidth requires a careful circuit design and proper PCB layout to prevent oscillations. In conclusion, the LM4562 is not quite suitable for experimentation-boards or simple drop-in replacement in any circuit. This preamp design can also accommodate pin-compatible replacement op-amps which are easier to obtain. Acceptable alternatives for the LM4562 are the OPA2134, OPA2604 or NE5532.

The attenuator requires a relatively large number of resistors. In high-end audio, stories circulate on the sonic qualities of various types of resistors. I am convinced that best audio quality is achieved -where possible- with simple, but well-designed circuits using high-quality components. However, I also know that high-quality audio components are often over-priced and applied in places where their return-on-investment is too low. With that in mind:

- I do NOT recommend to apply low-cost small (0.25W) metal-film resistors. Such resistors tend to add harshness to the sound.
- It is often claimed that the use of good-old (and inexpensive) carbon resistors results in better sound. Unfortunately, these resistors typically have a 5% tolerance, which I consider unacceptable for this attenuator. With such a tolerance not only the step size is inaccurate, the same holds for the similarity of the left and right (or + and -) channel. If you want to use 5% resistors, I advise to buy a larger quantity, measure their values, and apply matched components. (Their matching is more important than their absolute value.)
- The component table lists 0.5W or 1W metal film resistors with 1% accuracy. The preamp PCB was designed to fit resistors of this size: it has a hole-distance of 0.7" ( $\pm$  18 mm). Among the available brands, I propose that you check their data sheets on the 'current noise' specification, expressed in  $\mu\text{V/V}$ . Typically, the larger-power resistors show a better (lower) number. This current noise is not noticeable as noise-level in the audio. However, I believe that a better number indicates a better constructed resistor leading to improved sound quality.
- For this preamp I use the Dale 'RN60' series resistors. These are 0.5W 1% metal films and widely recognised in the audio world as very good sounding resistors. Unfortunately, this size and the values needed make them hard to obtain for the hobbyist. In a one-to-one comparison against Vishay-Beyslag MBE 1W resistors in one of my attenuators, I observed a somewhat cleaner and warmer sound from the Dales. Such differences are small, and whether they are audible also depends on your other audio components.
- Of course you are free to try significantly more expensive resistors, such as 'bulk metal foil' or 'tantalum' resistors, which are both recommended for their audio quality. I have no personal experience with them, but will be happy to hear your results!

### About resistor values:

Most metal film resistors have a 5-ring colour code, with a final brown ring indicating their 1% tolerance. Colour coding is documented for instance on [http://www.logwell.com/tech/components/1resistor\\_color\\_code.html](http://www.logwell.com/tech/components/1resistor_color_code.html) or with a calculator on [http://www.samengstrom.com/nxl/10116/5\\_band\\_resistor\\_color\\_code\\_page.en.html](http://www.samengstrom.com/nxl/10116/5_band_resistor_color_code_page.en.html). The Dale resistors indicate their value with a 4-digit number and one character. This corresponds with coloured ring coding: the first 3 digits provide a base value, and the 4<sup>th</sup> digit provides a powers-of-ten multiplier. This 4<sup>th</sup> digit must be read as the number of 0's after the first three digits. For example, a code of '8252F' indicates a value of '82500' ohms or 82.5 Kohms. The final 'F' indicates a 1% tolerance. Please mount these resistors in the PCB with this value code facing upwards, so that you can inspect proper placement in case difficulties with the attenuator are encountered. See my example:

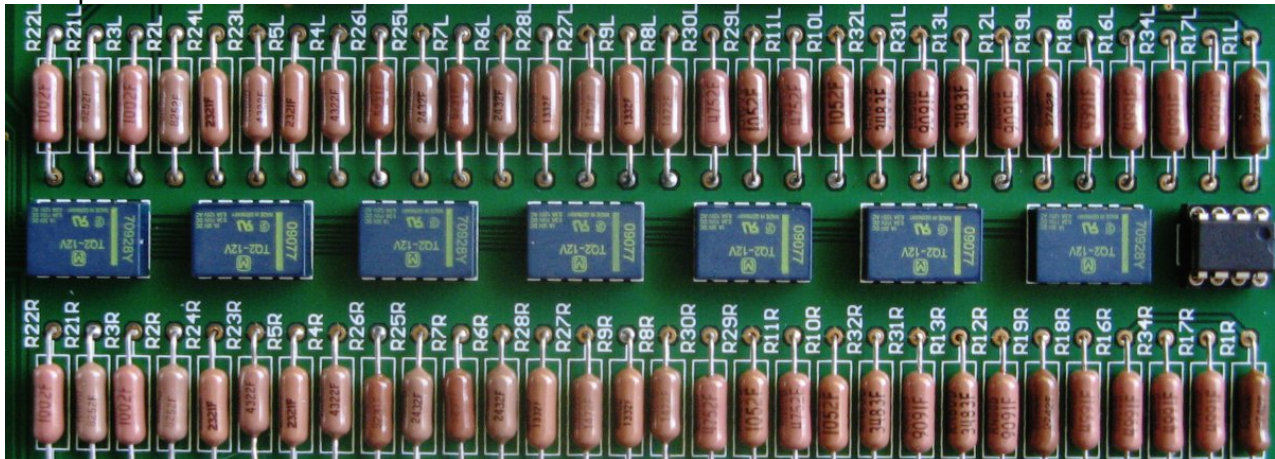

Appendix 1 shows a table with alternative resistor values should you want to buy your own set.

### About the 7-segment LED displays:

The design uses a pair of 7-segment displays in a 10-pin DIL housing, with a character height of 10 mm. They are of the 'common anode' type, so with a common connection to '+'. Note that such displays are available with different pin outs, so not any type will work in this PCB. Compare the pinning in the data sheets if you intend to buy other types than listed in my component table. The component table lists types with red LEDs. Red is well readable and creates a nice 'retro' look. Other colours are available as well. For instance Farnell has a pin-compatible blue version: 'FORGE EUROPA FN1-0392B050JGW' (part no.1200606), which is terribly expensive. Another compatible blue display is the Kingbright 'SA 39-11PBWA'. For yellow or green versions search in the Farnell site for 'HDSP-315'.

The display PCB also contains a pair of 'SIL' resistors: an 8-pin 'single-in-line' package containing 4 resistors. It seems that these are not so easy to obtain anymore. If you have difficulty with those, you can:

- Ask me. I will typically have some of these in house
- Apply traditional axial small (e.g. 0.1 W) resistors, mounted vertically (standing up). Probably you would like to bend them sideways, to avoid that they stand higher than the displays.
- Buy standard SMD resistors in size '0805', which you simply solder onto the soldering pads.

### Power supply components:

To obtain a more accurate match between the positive and negative reference voltage I prefer to use 1% accuracy resistors for R7P, R12P, R13P, R16P, and the TL431 'A' grade version (TL431ACL). If you find the J310 JFET not directly available, other JFETs are fine as long as they deliver enough current. The design is not sensitive to the actual value of the source current, which should be between 4mA and 8mA. Good replacements are the BF256C and BF245C. Note however that these two types have a different TO92 pin assignment: Their pin (1,

2, 3) connect to (drain, source, gate), whereas for the J310 this is (gate, source, drain). Therefore, you should mount a BF256/BF245 with its flat side of the package opposite to the indicated drawing on the PCB, and slightly bend the middle (source) wire to fit the rotated placement.

The 470pF capacitors (C30P, C33P, C35P, C37P) in the feedback of the power-supply opamps are an essential part of the power-supply behavior. Therefore, I suggest to pick a good-quality capacitor type for these. The generic low-cost 'multi-layer ceramic' will work without problem, but a better quality might have an audible effect. For myself I picked a small Wima foil (FKP2) capacitor, with polypropylene dielectric. Capacitors with 'NPO' dielectric are also good. These are often available as SMD capacitors: an '0805' (or even an '1206') package can be soldered on the PCB without much trouble.

For power-supply transformers, the schematics indicates a 2x6V, 6VA transformer for the digital section, and a 2x18V, 4VA transformer for the analog section. A low-power 2x7V transformer will also be fine for the digital power supply. If you would use a transformer with more power headroom (such as a 10VA type), it would typically create a rather high output voltage, since transformer output voltages are specified under maximum load. So, if your transformer is overpowered, I would advise to choose a lower voltage specification, such as 2x6V and 2x15V.

#### **About the PCB-mountable XLR connectors:**

The PCB footprint is designed to fit the Neutrik female NC3FAH or NC3FAAH series, and the male NC3MAH or NC3MAAH series. These connectors have a plastic housing and gold contacts. These 'series' still provide options like having a 'latch lock' (with a release push-button) or just a 'click and pull-back', having a 4<sup>th</sup> PCB pin that provides connection to the back panel, or having an internal connection between the back panel and the signal-ground pin 1. The PCB allows having a ground pin, but does not connect it: If you want to connect that to signal ground, you can add a small piece of wire between this pin 4 (labelled with 'G' on the PCB) and pin 1 at the bottom side of the PCB. If other XLR connectors are preferred, they must be wired manually to the PCB. An option would be a full-metal connector like the NC3FD-LX-B (e.g. part no. 1390117 at Farnell.com). As explained below, I prefer to NOT directly connect the chassis back panel to the PCB signal ground. If you end up with having a type that connects between the chassis (in the connector screw hole) and pin 1 and you do not want this connection, you can easily remove it from the connector. (Note that most literature claims that such a direct connection is fine.)

#### **About the rotary switch:**

The chosen type of switch provides rotary information to the microcontroller through two switch contacts that operate slightly out-of-phase with respect to each other. Furthermore, the switch also integrates a push-button. Several manufacturers provide such switches, I have experience with three specific types:

A:

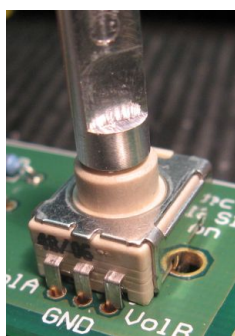

B:



C:



Type A, produced by DDM, is Conrad art.nr. 705594-89, which I have used for a long time already, and for which the PCB footprint was designed. It lacks a facility to screw it into a front plate. I only recently discovered type B in the Conrad catalog, art.nr. 700697-89. This switch from



Alps (type STEC11B03) seems a better choice: its clicks feel smoother, and the metal housing and shaft have a better fit, more suitable for heavy control knobs.

Type C is an Alps RK097 which I used for while as alternative to A (such as [here](#)). This one seems to me the best quality switch of these three, but it does not fit in the PCB. Both B and C can be mounted in a front-panel, providing freedom in choosing your own front layout, requiring 5 small wires from the switch to the PCB. If you are interested, I have a few of these type C switches in house. Bourns doe also produce several such switches, which might be easier available for you. A particular type no is for instance 'PEC11-4220F-S0024': 24 steps per rotation, with switch. From its datasheet it seems that its housing is slightly wider, meaning that its side tabs for mechanical fixture to the PCB will have a tight (or problematic) fit.

*Update in this Jan'09 revision:*

The schematics contain several capacitors from the stabilised voltages (V16 P/N L/R) to AGND. Each of these 4 power lines has a 1uF film cap, two 47nF and one 10nF multi-layer ceramic capacitor. These capacitors are meant to keep a clean power-supply and a stable operation of the audio opamps U1L and U1R. Due to the low output impedance of the power supply stabilization, these capacitors only become 'active' (have impact on the impedance) for frequencies in the range of 1MHz to 50MHz. In combination with the excellent 'power supply rejection' of the audio opamps, these capacitors should theoretically have no audible impact on the RelaiXed sonic quality. In practice however I have learned that these capacitors do have some audible effect. So, if you want the most out of your RelaiXed and/or want to do some experimentation, you can try some modifications here.

One update which seem to improve the sound quality is to replace the 47nF and 10nF capacitors: Normally these would be 'multi-layer ceramic' types with an 'X7R' type dielectric. Such are great for HF stabilisation, but not for fine audio. You can insert better quality capacitors with 'NP0' (or 'C0G') dielectric. As these are not easy to find in higher values, you can insert 10nF versions at all 12 locations. However, these 'NP0' caps are typically found only in SMD housing. The SMD '0805' housing will still fit this PCB: you can simple solder those on top of (across) the pair of 0.1" via's.

The relay-PCB and the display-PCB are connected by a one-to-one connection of the 5-pin headers J1D and J2D. *It is new for the Jan'09 firmware release* that pin 5 ('PGC') is used by the relay board to send back a handshake to the display board upon each switching command that the display board issues on pin 4 ('PGD'). Next to these two signal, obviously the GND signal on pin 3 must be interconnected. Pin2 ('+5V') is used to send a power supply from the relay board to the display. Pin 1 ('MCLR') is not used for normal RelaiXed operation, it is reserved for reprogramming the microcontroller. Interconnecting both pin 1's is not needed, but is also harmless.

For multi-channel audio operation, a single display PCB can control several relay PCB's in parallel. This is accomplished by:

- Pin 3 (GND), pin 4 (PGD), and pin 5 (PGC) are interconnected among the display PCB and **all** relay PCB's.
- Pin 2 (+5V) is connected from **only one** relay PCB to the display PCB.
- Pin 1 (MCLR) doesn't matter.

Some persons would like to implement a relay board as 'slave' in combination with a power amp monoblock, such that the relay board is located a few meters away from one shared display controller. That is still fine. For such a remote operation you would need to send GND and two signals (PGD and PGC), through a shielded cable.

## Building this preamplifier

The PCB assembly process hardly needs further explanation. The design relies on conventional, easy to handle through-hole components. All component identifiers are named (identified) with a number and a trailing character that corresponds to the schematic sheet. You find these component identifiers in the schematics, printed on the PCB, and listed in the component table as well.

The front panel PCB and the relay-PCB are produced as a single piece. I will have separated them before sending, so you will receive two separate PCBs. For mounting/soldering all components, choose a sequence with the lowest profile components first. That allows fixing of the components while PCB is upside-down on the desk. Hence they are fixed such that soldering does not change their position:

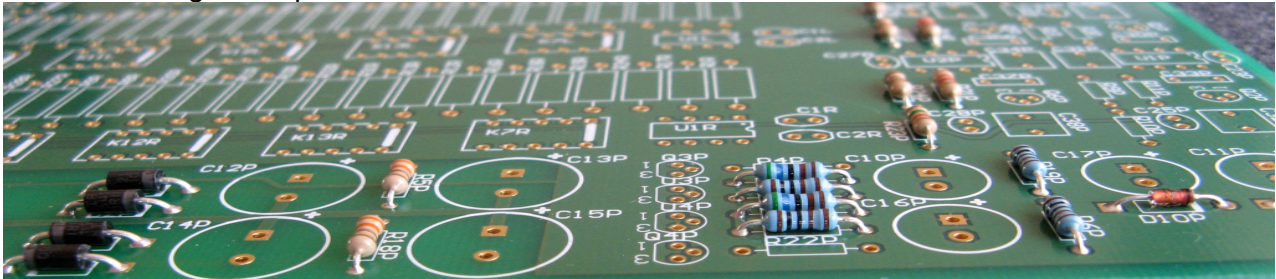

For easy and neat mounting of resistors and diodes it is convenient to use a lead bending tool such as in the neighbouring picture. You will benefit from spending a few euro's on this. Unfortunately, these tools are out of fashion. Here (in the Netherlands) they can still be obtained via 'Display.nl', part no. 08.90.212.



Normally, I prefer not to use IC sockets. However, for the RelaiXed I do advise to use IC sockets: Plugging the audio op amps into a socket has the advantage that at a later stage you can easily update the preamp to use a newer/different type for best sound quality. Plugging the two micro controllers into a socket has the strong advantage that you can later take them out easily, and mail them back to me for a firmware update (I admit: my software tends to need bug fixes.) PLEASE double- and triple- check the orientation of the relays, the led-displays and IC's before soldering: It will be almost impossible to 'de-solder' DIL (dual-in-line) components out of a PCB because of its through-metallised via's. Note that the PCB layout uses square terminals to identify pin 1 and round terminals for all other pins. The SIL-resistors R5D and R6D are symmetrical components, and can be placed in either orientation.

The voltage regulators U5P and U6P should be preferably flat-mounted on the PCB, and fixed with small M3 bolts. The PCB top-layer ground plane is bare-metal (pure gold ☺) underneath these ICs, which helps to conduct the heat away from them. There is no need for any insulation, as the back-side of these IC's is connected to ground anyhow. There is no need for heat-conducting paste between the IC's and the PCB: the dissipation is so low that under extreme conditions the IC's will become only mildly warm.

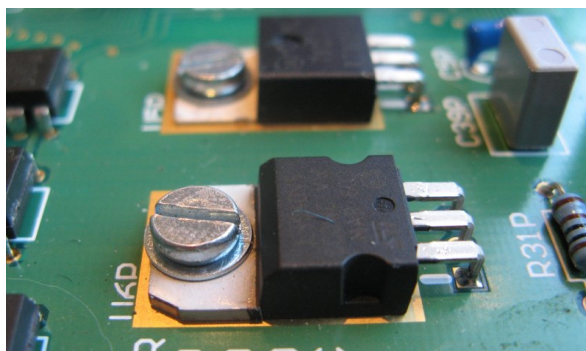

As exception to the 'normal' mounting order, prior to mounting the 4 op amps and the 2 micro controllers: complete all mounting except these 6 IC's and the XLR connectors. We can now first test the correct operation of the power supplies before inserting these IC's, avoiding the risk to blow them due to some earlier mistake. So, without the 4 op amps and 2 micro controllers U1D and U2D, you connect the two transformers, and power them up. Now the following voltages must be checked:

- a) On both ends of R5P, vs. AGND (e.g. pin 4 of U1P), a voltage between 21V and 28V must be measured.
- b) On both ends of R18P there must be a voltage between -21V and -28V and AGND.
- c) On both ends of R6P a voltage between 16V and 17V.
- d) On both ends of R19P a voltage between -16V and -17V.
- e) On U6P (L4940) vs. DGND (e.g. its middle pin) a voltage between 7.0V and 10.0V on the input (pin 1), and 5.0V on the output (pin 3).
- f) The same 5.0 V should be measured on pin 14 of both micro controllers U1D and U2D (with a connected front panel) vs. DGND. Note: L1D and L2D remain dark if U2D is not mounted.
- g) On U5P (LM7812) the voltage should be 15V to 20V on the input (pin 1), and 12V on the output (pin 3), relative to DGND.
- h) There is almost no DC voltage drop between the 2 terminals of R5P, R18P, R25P, R29P. (Later on, when the preamp is in full use, its power consumption will create a small DC voltage drop here.)
- i) R27P must has no DC voltage drop between its terminals.

Now you can switch off the preamp, let the capacitors discharge, and insert U1P and U2P. If you power up the transformers again, you should find 16V-17V on pin 8 of U1R and U1L, and -16V to -17V on pin 4 of U1R and U1L. If that is correct, you can switch off the preamp again, and finally insert U1L, U1R, U1D and U2D. The design imposes no constraints on the order of powering up the two transformers: the design is not damaged in any way if only one of the two transformers has power.

The LED L1P is always on if the digital power transformer is 'on'. This shows that the power is on, but also ensures a minimum load current for the LM7812 what it needs for correct operation. Alternatively, you can remove this LED and replace it with a wire-bridge, ensuring that the load current through R26P remains. Also, you can mount L1P somewhere in your front-panel instead of on the PCB. Note however, that the 2-digit front display also has its last 'decimal dot' always on as power indicator. Similarly, this also holds for the minimum current consumption from U6P, what it needs for correct operation.

The component list shows two types of rotary switches available from 'Conrad' that fit in the front-PCB. You are also free not to mount (not use) a rotary switch: The preamp can be operated solely from an IR remote control unit. Alternatively, I can also provide a front-mount high-quality Alps rotary switch that is not intended (fit) for PCB mounting, and can be positioned further away from the display if this is preferred.

J1D and J2D are 5-pin headers that connect to the adjacent PIC16F819 micro controller for the set of 5 pins that are used for 'ICSP' (in-circuit serial programming). The same headers also link the relay PCB and the front PCB. (I find it attractive to buy connectors complete with attached wires, as shown for instance in the Conrad component table. Although the component table -in agreement with the PCB layout- lists the need for 2x 5-pin connectors, you clearly need to buy only one of such a connector-with-wiring assembly.)

As tallest components, the XLR connectors must be soldered-in last.

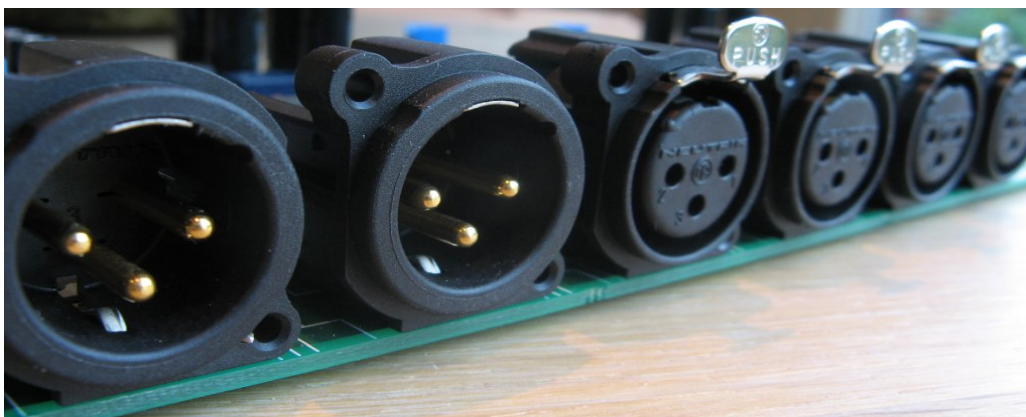

If you want to equip the preamp with 3 pair of XLR inputs plus 3 pair cinch inputs, diode D4D should NOT be mounted. Alternatively, if you want 2 XLR inputs and 4 cinch inputs, do insert D4D, and connect the 4<sup>th</sup> cinch pair to the pins marked with '+' on J4L and J4R.

Of course, remarks about basic soldering techniques are not needed, as you already have good skills in soldering... This is how the bottom side of my PCB looks like. A nice smooth and shiny soldering joint is made by having your soldering wire close to the

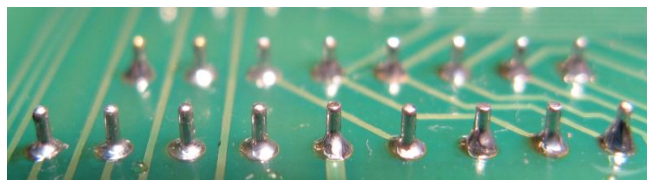

soldering pad, so that it melts on the pad. If you melt the solder on the tip of your soldering-iron, and wait a few seconds before applying it to the pad&component, it will not attach nicely. If you do a faster job, you get a better result, and reduce the risc of overheating your components. Traditional solder wire has a tin-lead metal mixture with about 40% lead. This the easiest type to work with. For environmental reasons, lead is currently being avoided for soldering. A beautiful alternative is the tin-copper-silver mixture. The (typically 3%) silver content is by some audio enthusiasts appraised for giving better sounding results. As all lead-free types, this has a somewhat higher melting temperature. Also, this type of solder cools down to a grayisch appearance, not very shiny. Finally, thin soldering wire like 0.5 to 0.7 mm, is strongly preferred for this kind of PCB assembly.

## Testing

The power supply voltages as have been checked in the previous chapter. You can test the correct sequence of the resistor-relay attenuator chain when your RelaiXed is finished and ready for operation: the powersupplies are up and running, the opamps are in place, the front-PCB is connected and can be operated from its rotary/pushbutton switch.

We will test the input-to-output amplification for a DC input voltage, separate for each of the 4 attenuator chains.

- Connect a DC voltmeter to the 'left negative' output, e.g. to the right end of R15L, with the meter GND (or -) to the ground plane, e.g. on the top side of R12L. (Of course, you could also use the XLR terminal connections.)
- Just for this measurement, make a temporary connection from the +5V supply to the 'in left pos' signal, e.g. on R3L, its front-side pin. You can pick +5V from the right pin of U6P, or from the left pin of R31P. See my photo:

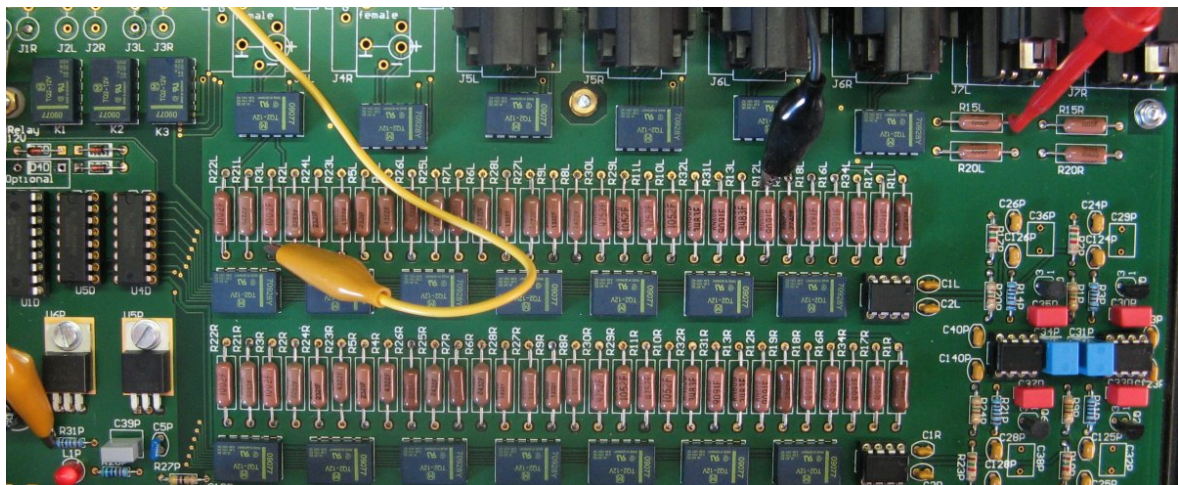

- Power-up both powersupply transformers.
- Turn the volume level up to '64'. Choose a balanced input channel, e.g. input '6'.
- The voltmeter should read about -9.7V (+/- 5%).
- If you reconnect the voltmeter to the 'left positive output', e.g. on the right side of R20L, you will measure +5.6V.
- Now reconnect the voltmeter to R15L. If you turn the volume down step-by-step, the voltage reading should go down regularly, according to the table below (omit the '-' sign). Due to rounding and to resistor inaccuracies, your actual reading can deviate about 5%.

Volume	Voltage	Volume	Voltage	Volume	Voltage	Volume	Voltage
64	9.70	48	1.54	32	0.244	16	0.0386
63	8.65	47	1.37	31	0.217	15	0.0344
62	7.70	46	1.22	30	0.194	14	0.0307
61	6.87	45	1.09	29	0.172	13	0.0273
60	6.12	44	0.97	28	0.154	12	0.0244
59	5.45	43	0.86	27	0.137	11	0.0217
58	4.86	42	0.77	26	0.122	10	0.0194
57	4.33	41	0.69	25	0.109	9	0.0172
56	3.86	40	0.61	24	0.097	8	0.0154
55	3.44	39	0.55	23	0.086	7	0.0137
54	3.07	38	0.49	22	0.077	6	0.0122
53	2.73	37	0.43	21	0.069	5	0.0109
52	2.44	36	0.39	20	0.061	4	0.0097
51	2.17	35	0.34	19	0.055	3	0.0086
50	1.94	34	0.31	18	0.049	2	0.0077
49	1.72	33	0.27	17	0.043	1	0.0069

- h) Do the same type of measurement for the other three attenuator chains:
  - i. Connect the +5V to R22L, front-side pin, connect the voltmeter to R20L
  - ii. Connect the +5V to R3R, front-side pin, connect the voltmeter to R15R
  - iii. Connect the +5V to R22R, front-side pin, connect the voltmeter to R20R

Note the logarithmic behavior of the attenuator: for every step the voltage changes with a factor of about 1.12x, which corresponds to a 1dB change in sound level. If your preamp passes this test, congratulations! You have built a correctly working preamp!

If you power-up (only) the low-voltage digital supply on the relay board, you can check the voltages on the 5-pin connector to the display board: at pin 2 (+5V) and at pin 4(PGD) you should measure +5V, the other three pins should read as 0V. This remains so if the display-board is connected.

*It is new for the Jan'09 firmware release that the display board and relay board perform a handshake operation through their 5-pin connector. If the display shows 'E1.' the pin 5 is not at 0V (idle). Probably, the display pin 5 is not properly connected to the relay board (is left open). If the display shows 'EO.' the relay board does not confirm proper reception of a switching command and something else is wrong. (The signal is inadvertently tied to GND, or the relay firmware is not properly installed.)*

## Chassis routing and grounding considerations

How to ground audio equipment is a topic with endless discussions. My personal preference is to apply the following set of rules for ALL the chassis of your audio set:

- a) Connect a 'real earth' through the power-cord and connector to each chassis. If a 'real earth' is not available, at least connects all chassis/cabinets are connected to each other.
- b) Use high-quality audio connectors (cinch, speaker, XLR) that are isolated from the cabinet.
- c) Inside the cabinet all signal grounds (left and right, input and output) are tied together. (In this preamp on the PCB ground plane.)
- d) A damping resistor of for instance 47 or 100ohm is applied in each cabinet as the only connection between the chassis and signal ground. (Preferably close to the chassis back panel and audio connectors.)

The direct earth-to-chassis connection provides safety ground. The damping resistor prevents cycling of significant stray currents between different devices through the power-ground cord and the signal ground connections. Note that 'official' XLR documents prescribe that it is best to make a hard-wired connection between the chassis and the signal-ground at the point of the back panel of the cabinet. I agree that this is good for HF rejection, but it is -in my opinion- not a good strategy in combination with (unbalanced) cinch connectors.

The preamp design provides an option to drive a power relay to switch the 230V AC line of its own audio (2x18V) transformer and/or other equipment such as a power-amplifier. This gives the capability to use your remote control to switch on/off your complete audio set.

If the power relay is applied as in the schematics below to switch-off everything except the 2x7V digital power supply transformer, the preamp power consumption is minimized in the power-down mode. My (somewhat crude) measurement shows a remaining power consumption on the 230V AC line of 1.2W. This power is mainly due to losses in the low-cost transformer. At an electricity cost of €0.20/kWh, this permanently powered preamp will cost you about 0.6ct/day or €2.10/yr on energy. If you do not insert the relay, both power supplies are in operation continuously, and the preamp takes 10W. Most of this power is dissipated in the analogue power supply. Of course, the IR reception remains operational in power down mode, and allows to switch back to normal operation.

The power measurements listed above clearly show different transformer qualities. The above 1.2W was consumed by a low-cost 2x6V-5VA print-mount transformer of roughly €5,=. Doing the same measurement with a duo of small 7VA toroid transformers of about €15, gives a power reading of 8W in full operation and a drop to 0.1W (!) in preamp power-down mode. Although this 0.1W is clearly below my measurement accuracy, these measurements do show that it is very well possible to design always-on equipment with really negligible power consumption.

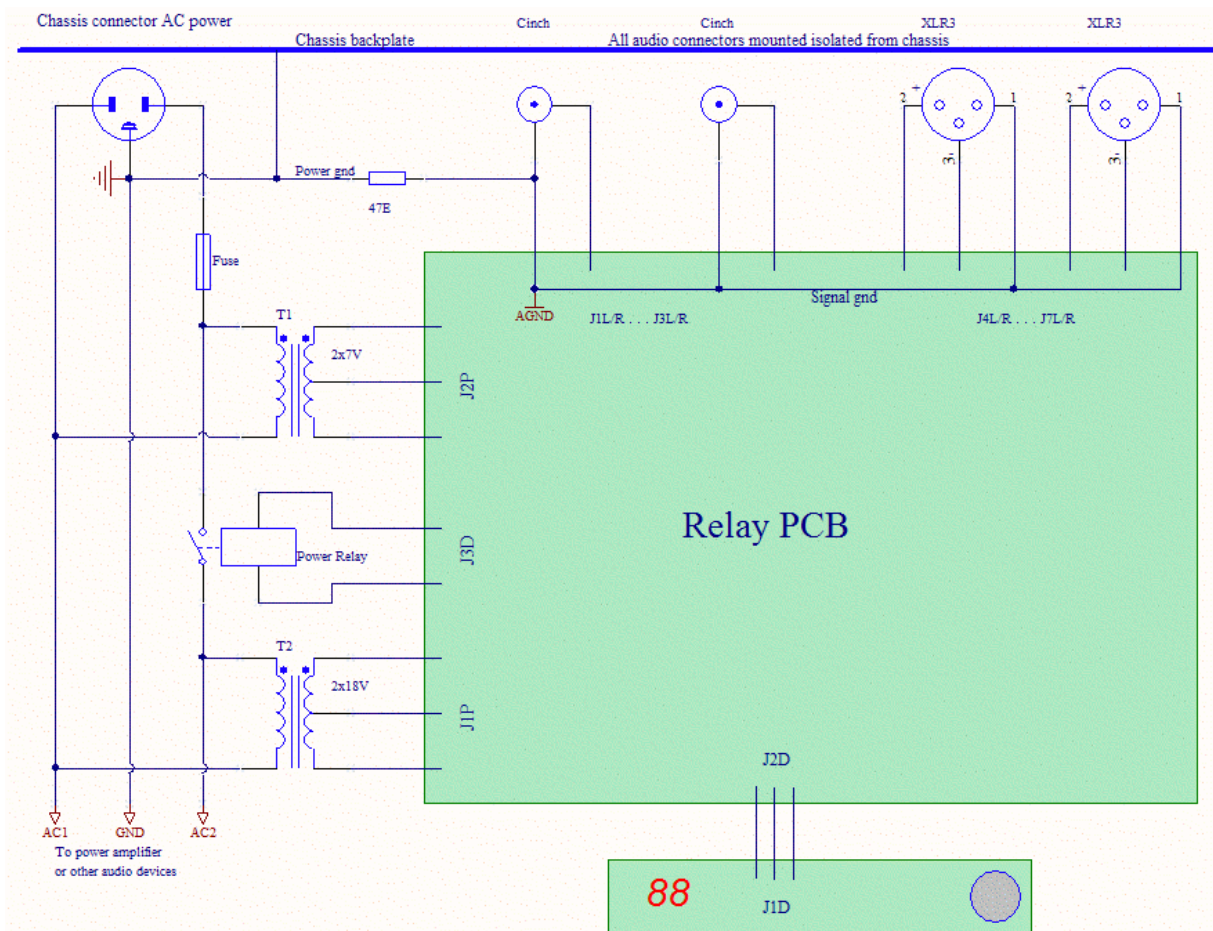

If you intend to switch a heavy transformer of a power amplifier, it is probably a good idea to add a 'varistor' across the primary side of the transformer. A varistor will prevent that switching-off the transformer creates a high-voltage arc across the relays contacts. The varistor will thus help in maintaining a proper lifetime of the relay. In any case, I would select a significantly over-powered relay, to obtain a trouble-free and very long lifetime.

As alternative to using the power-relay inside the preamp chassis, you can also consider using it externally: Lead the two relay control wires from J3D to a (low-voltage type) DC-plug-connector to the back of your preamp. Build the relay inside a power-line socket strip, intended for main power distribution. To connect to the preamp create a low-voltage wire from the relay-coil to a DC-plug, to connect to the preamp. You can now switch a bunch of external equipment with your remote control....



## Remote controller compatibility

First thing to do, is to find your own remote control hand-held that transmits IR signals in a format that is understood by the preamp. There are many different formats, some of them are shared by multiple companies/brands. Clearly, within each format, many different codes are used for activating different functions on different devices. Your preamp understands the classic Philips RC5 and their newer RC6 format, as well as the Sony SIRC protocol. For technical information on these formats see for instance the nice website at <http://www.sbprojects.com/knowledge/ir/ir.htm>. All generic (multi-brand) IR remotes can send these formats.

I verified with some remotes from JVC and Samsung (that use other unsupported protocols) that those do not interfere by causing unintended activity.

*Note: the text below, including the following chapters, was revised to reflect the new behavior of the Jan.'09 firmware release.*

If you power-up RelaiXed (the display PCB), and everything works fine, the display starts to count up from '**10.**' to '**30.**' in steps of 2, about a second per step. This reflects the ramp-up of the audio volume, towards the volume that was used before power-down. During this volume-rampup immediately following power-up, the preamp is sensitive to enter a special programming mode.

In sending a IR signal to the device during this volume-rampup three reactions are possible:

- '**--.**' This indicates that the device cannot deal with the format of the received IR signal. You have to find yourself a different remote (or, for a multi-brand remote, experiment with a different mode) to control the attenuator.
- '**P1.**' A 'P' and one digit indicate entering programming mode. More on that in the next chapter. This mode is automatically left after idling for about 5 seconds.
- '**31.**' A two-digit numeric result means that the device performs a volume adjustment on an understood button function.
- '**C1.**' A 'C' and one digit indicate the selection of another audio input channel.
- '**E1.**' or '**E0.**' signals an error in the display-to-relay board connections.

After the initial volume-rampup is finished, and program-mode isn't activated, only the latter two reactions can appear on the display. The preamp will silently ignore all IR-signals that are not understood. (Assuming they target some other device.) In its initial firmware state, the preamp is sensitive to volume and channel IR commands in Philips' RC5 protocol, in accordance with a default (television) device setting.

## Configuring IR reception

With a compatible IR-remote you can proceed with learning your preamp to react properly on your favourite buttons.

- a. Within 10 seconds or so after power-up, during the volume ramp-up, you press the '9' digit button on your remote. The attenuator reacts with '**P1.**' on its display. (The preamp will detect this '9' button from all RC5/RC6/SIRC remotes, irrespective of any device selection.)
- b. You can freely press '9' repeatedly, thereby cycling through '**P1.**', '**P2.**', ... '**P9.**', '**P1.**'... If you do not press anything for about 5 seconds, the display will go back to show '**C1.**' (the currently selected input channel) and '**15.**' (the current volume), indicating that you have left the programming mode.
- c. If the display shows '**P1.**', and you press any button other than '9', that button code is stored in non-volatile memory and will be used later for 'Volume Up'. The display reacts with '**1.**' to confirm the programming of function 1. If you receive a '**PF.**' reaction, the attenuator failed to extract a proper IR code. In any case, pressing '9' again will move you to the next button to configure.

In repeating steps b. and c. (and/or a.), you can configure the following button codes:

- '**P1.**' Volume Up
- '**P2.**' Volume Down
- '**P3.**' Mute on/off
- '**P4.**' Input channel Up
- '**P5.**' Input channel Down
- '**P6.**' Input channel select number 1
- '**P7.**' Input channel select number 6 (highest channel number)
- '**P8.**' Power-down
- '**P9.**' Display mode

The numeric keypad on your remote can be used to select the audio input channel. For this purpose, the signals of the first button '1' and the last button '6' must be programmed. As an exception, by choosing another value than '6', you may program a different number of input channels. Programming a value of '4' restricts later channel selections from 1 to 4 only.

Some persons prefer to use a small remote in combination with the attenuator, which only has 4 or 5 buttons. With these, you can do volume up/down and channel up/down, but obviously not numeric input channel selection. To program the codes of such a remote in the attenuator, you seem to miss the '9' button to enter programming mode. In this case, you can use the '9' button of some other remote that you will not use later to operate the attenuator.

The 'power down' button not only activates an optionally connected power-relay to switch off, but also switches-off all on-board relays, thereby silencing the output signal. In the power-down mode the preamp does not respond to volume up/down or mute commands. All RelaiXed functions are activated again if a channel-select or a 'power down' command is given.

P9 is not intended to enable an extra button function. It changes the mode of the display itself. In the default mode, the preamp continuously displays the current volume setting, except in power-down mode where it only shows '█.'. If the P9 location is programmed with a different key as P8, e.g. some digit, the preamp displays a reaction to the last command, i.e. by showing the most recent input channel selected or the newly selected volume level during about a second. Hereafter the display will always return to idle (black). Some people prefer such a normally-black display. If you program P9 with the same button as P8, you will go back to the initial behaviour with a continuous volume-level display.

Note that the attenuator not only learns (stores) the specific buttons that you choose from your remote. It also stores the 'device code' that the remote issues as part of the normal IR protocol. Therefore, if your remote has a 'device select' function to control different devices, the attenuator will learn to only react on your selected device. This will help to avoid confusion with different IR-receivers in your A/V system.

## Ready to use

At power-up you see the attenuator ramping-up its audio volume in 10 steps of 2dB, reaching the volume it had before the last power-down. Also, it will select the last used audio input channel. The volume ramp-up is immediately terminated when you select a new volume or input channel. Sending a command will display the new volume set or input channel selected. Channel select up/down wraps cyclic over the available inputs. Pressing digit 1 to 6 selects the corresponding input channel. The 'mute' command both mutes and un-mutes. Changing the volume during mute directly restores the previous volume. The 'power down' command performs power down but also power-up when issued after a short delay. Power-up is also induced by input channel selection.

The preamp normally can be built with the rotary switch in the front-panel, although having this switch may be considered optional. Turning the rotary increases or decreases the audio volume. This type of switch has no end-point: it gives purely incremental (relative) updates. At the scale end-points (volume 64 and 00) the volume level is clipped by the micro controller firmware. If the preamp is in the 'mute' state, turning the volume ends this. The rotary switch type proposed also has a built-in push-button. Clicking this (pressing on the knob), switches to the next audio input channel. After channel '6' it cycles back to '1'. If the preamp was in 'power down' mode, the first click will only power-up the preamp. If you keep the button pressed for about 5 seconds the preamp will turn-off (go to power-down state).

The preamp display PCB stores its last used volume and channel selection in non-volatile (EPROM) memory. If the AC power is restored, it starts up with these (saved) settings.

Happy listening!

Jos van Eijndhoven

Jan 2009

## Appendix1: Resistor table

Values for the audio-grade resistors in the attenuator stages and the opamp output stage can be chosen from different value series. The courser (E12 and E24) values give some non-uniformity in the intended 1.0dB gain-difference per volume step. (In detail: the E12 series results in a RMS average deviation of 0.2dB, the E48 series in an average deviation of 0.04dB) For any E-series, the use of 1% resistors is recommended for uniformity between the four audio channels. The Dale resistor set that I can provide is according the E96 series of values.

<b>Resistor Ids (-L and -R)</b>	<b>E12</b>	<b>E24</b>	<b>E48</b>	<b>E96</b>
R2, R21	82K	82K	82.5K	82.5K
R3, R22	10K	10K	10.0K	10.0K
R4, R23	47K	43K	44.2K	43.2K
R5, R24	2.2K	2.4K	2.26K	2.32K
R6, R25	27K	24K	23.7K	24.3K
R7, R26	5.6K	5.1K	5.11K	5.23K
R8, R27	15K	15K	14.7K	14.7K
R9, R28	15K	13K	13.3K	13.3K
R10, R29	10K	11K	10.5K	10.5K
R11, R30	47K	47K	46.4K	47.5K
R12, R31	10K	9.1K	9.09K	9.09K
R13, R32	330K	360K	348K	348K
R1, R19	27K	27K	27.4K	27.4K
R16, R17, R18, R34	4.7K	4.7K	4.87K	4.99K
R15, R20	100R	100R	100R	100R

### Adjusting the parameters of the output stage:

The (differential) gain of the opamp stage (at maximum volume) is determined by (feedback resistor / attenuator output resistance) and is  $(R1 / 8.9K)$ . For the 'standard' resistors this is about 3x. You can adjust this gain by changing the values of R1L/R1R/R19L/R19R to a different value. If a supposedly balanced input signal contains a common-mode component, this common-mode signal is amplified to a common-mode output with a gain of  $((R1//2xR16) / \text{attenuator output resistance})$ , which is about 0.8x. When R1,R19 is modified to choose a different gain, I propose to proportionally adjust R16,R17,R18,R34. If you reduce the value of R16 relatively to R1, you improve the common-mode rejection of the design. However this comes at the cost of a strongly increasing DC offset voltage at the outputs.

One particular adjustment that people have asked me, is to set the maximum gain of the design (the gain at maximum volume) to unity (0 dB). This is achieved by choosing the following:

<b>Resistor Ids (-L and -R)</b>	<b>E12</b>	<b>E24</b>	<b>E48</b>	<b>E96</b>
R1, R19	10K	9.1K	9.09K	8.87K
R16, R17, R18, R34	1.5K	1.5K	1.47K	1.50K

## Appendix 2: Building RelaiXed with cinch-inputs only

The regular RelaiXed configuration combines 3 or 4 single-ended (cinch) inputs with 3 respectively 2 balanced (XLR) inputs. Some persons have asked me to configure RelaiXed to operate with 6 cinch inputs. This can be achieved in different ways, depending on the intent to simultaneously reduce the component cost. With the modifications proposed below, the RelaiXed output will remain a symmetrical, balanced signal through its default XLR connectors.

### De-configuration A)

Relais K7L and K7R switch the output gain configuration to use a balanced input (when in rest) or a single-ended input (when activated). When all inputs are single-ended, this switching is not needed, and the 'single-ended' configuration can be obtained by simply NOT mounting these two relays. In this case, also diodes D1D to D4D have become superfluous, and can be omitted. The lower attenuator chains (R21L to R32L, R19L, R21R to R32R, and R19R) are not used, and those 26 resistors can also be omitted.

In this set-up, obtained by just omitting components, the relais K4L/R to K6L/R and K8L/R to K13L/R all remain, although only one switch contact per relay is used. Note that also all opamps remain, with the full power-supply circuit, to create the balanced output signals.

The cinch input signals for input channels 4,5, and 6 are wired to the '+' inputs of the balanced connector footprint on the PCB ('left' cinch signal to the 'left' XLR footprint, and the 'right' cinch signal to the 'right' XLR footprint.)

### De-configuration B)

You would only save significantly on component cost, if more relais could be omitted. This is obtained with this somewhat more complex alternative: the relais K1 to K3, K4L to K6L, and K8L to K13L remain, and all K\*R relays are omitted, as well as both K7L/R relais. So, just 12 relais remain of the original 23.

The signal that is named 'inleftneg' in the schematics will be rewired to function as 'inrightpos'. All resistors around the 'right' attenuator relais are omitted: R2R to R13R, R21R to R32R, and R19R. You also remove R19L. You keep the -L and -R versions of R1, R16, R17, R18, R34.

You add a wire against the bottom-side of the PCB to connect (short-cut) the signals 'inleftneg' and 'inrightpos', for instance between pin 3 of K3 and pin 8 of K4L.

You add a wire from pin 8 of (the absent) K7L to the nearby topside (backside) of R13R (which also connects to pin 6 of U1R). Again, you keep all opamps, and the full power-supply circuit.

For the cinch input channels 4,5, and 6, you wire the 'left' input signals to the 'left +' XLR footprints, and the 'right' inputs to the 'left -' XLR footprints. The J4R, J5R, and J6R footprints remain unused.

This B-configuration ends up with a resistor-relay layout where the left- and right- channel signals are somewhat strongly intertwined. I did not measure or listen whether this has audible consequences.