

Replacement Packing for Dozens of Elevator Models

THE BEST "PRESSURE-BALANCED" PACKING

All packing featured on the following pages is top-grade "Pressure-Balanced" packing. Adams packing works well in all elevators. . . and you'll notice the greatest improvement in elevators with rough start-up.

Adams packing can reduce break-away friction up to 35%. Adams packing also reduces running friction and seal-related noises in all elevators, increasing the life of the seal.

BEARING RINGS AND PACKING KITS

Starting on the next page, you'll find general-purpose packing and Packing Kits. The description for each kit gives the following helpful information:

- Original manufacturer's name and model numbers
- List of kit contents
- Easy-reference ordering table
- Piston diameter
- Schematic diagram

Bearing rings are not always necessary. But when they are, you'll find bearing rings listed in each manufacturer's section. This information is provided for each type:

- Easy-to-use ordering table
- Bearing ring dimensions
- Piston diameter
- Schematic diagram

DIAGRAMS SHOW EACH COMPONENT

Helpful drawings of each OEM packing stack and bearing ring eliminate guesswork when ordering a replacement.

Dimensions are given for each component.

This section has been designed to help you save time and labor by ordering the right part the first time.

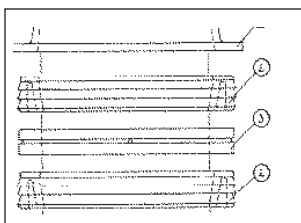

DIAMETER TAPE MEASURE

A560D. Measures diameter in centimeters and inches. "Must have" for every toolbox.

GLOSSARY OF PACKING TERMS

Seal — A rubber and/or fibrous washer-like ring used to keep hydraulic oil from escaping out of the cylinder head as the piston moves up and down. Seals are generally used in combination with other packing elements (described below). Seals are also known by the names "glands" and "gland rings."

Wiper — The top-most element in a packing set. The wiper keeps dirt from entering the closed system of hydro fluid by "wiping" the piston clean as it moves up and down through the packing box at the top of the cylinder.

Lantern ring — Used between two seals to collect excess hydraulic oil and allow it to be forced out of the cylinder head. This oil run-off can then be fed by hose or pipe directly back into the oil tank or into a pit can for recycling later.

Bearing ring — Heavy-duty packing element (usually at the top or bottom of the packing box) that keeps the piston centered in the box opening.

KRAMM PACKING: ONE-SIZE-FITS-ALL GCI WORM GEAR PACKING

Made from solid mineral lubricants, graphite, & adhesives.

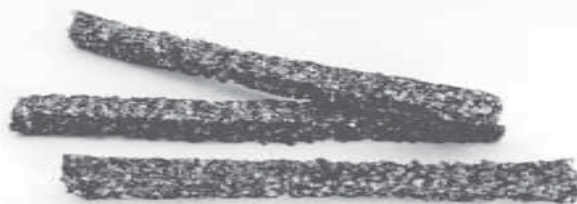

Adams part no. GPX100. One lb./pkg.

PACKING KITS AND COMPONENTS

FIT 17 JACK DIAMETERS

Seals (gland rings) are "Pressure-Balanced" type. They form a tight seal even without firm compression. These seals are recommended for applications from 0-1500 psi. All seals are 5/8" thick.

One or two seals form a positive seal under all conditions. Check the application for the number of seals required. When using two seals, sandwich an oil-return lantern ring between the seals. Additional lantern rings can be ordered separately.

Use Adams economical general purpose packing any time you can match the packing jack diameter to the hydro being serviced, and when the height of the packing stack completely fills the packing box (or if you plan to fill any gaps with another packing material).

Refer to the ordering table below to find part numbers for the diameters of the jack and packing box you are servicing. Remember, don't get caught short; if you're not sure what part is causing the leak, order the entire kit...*you'll be glad you did!*

NOTE: Packing is available for jack diameters as narrow as 3" and as wide as 17 7/8". Standard sizes are listed in the table below; some are shown in photo at right.

Each Adams packing set contains:



Packing components are available from stock for jack diameters from 4" up to 10 5/8"

PACKING KITS & COMPONENTS

Jack diameter	Packing box diameter	Complete packing set	P/N's for Separate Components		
			Seal (gland ring)	Wiper ring (& clips)	Lantern ring
4"	5"	GP4000	GP4000G	GP4000W	GP4000L
4 3/8"	5 3/8"	GP4375	GP4375G	GP4375W	GP4375L
4 1/2"	5 1/2"	GP4500	GP4500G	GP4500W	GP4500L
5"	6"	GP5000	GP5000G	GP5000W	GP5000L
5 1/4"	6 1/4"	GP5250	GP5250G	GP5250W	GP5250L
5 3/8"	6 3/8"	GP5375	GP5375G	GP5375W	GP5375L
5 7/16"	6 7/16"	GP5437	GP5437G	GP5437W	GP5437L
5 1/2"	6 1/2"	GP5500	GP5500G	GP5500W	GP5500L
5 3/4"	6 3/4"	GP5750	GP5750G	GP5750W	GP5750L
6"	7"	GP6000	GP6000G	GP6000W	GP6000L
6 1/2"	7 1/2"	GP6500	GP6500G	GP6500W	GP6500L
7"	8"	GP7000	GP7000G	GP7000W	GP7000L
7 1/2"	8 1/2"	GP7500	GP7500G	GP7500W	GP7500L
8"	9"	GP8000	GP8000G	GP8000W	GP8000L
8 1/2"	9 1/2"	GP8500	GP8500G	GP8500W	GP8500L
9 1/2"	10 1/2"	GP9500	GP9500G	GP9500W	GP9500L
10 5/8"	11 5/8"	GP10625	GP10625G	GP10625W	GP10625L



PACKING PULLERS

GP100. Set of two pulling tools to help simplify the tough job of removing and replacing worn hydraulic packing elements.

Screwdriver-type handles, flexible stems, and threaded ends for reaching and grabbing in tight places at almost any angle.

AMCO/WHITE EVANS HYDRAULIC PACKING KITS

Each hydraulic packing kit for AMCO/White Evans consists of:

- Two (2) seals
- One (1) wiper

AMCO/WHITE EVANS		
Adams part no.	Piston Description	Bearing No.
GK03500WE	3 1/2"	GB03500B6
GK04000WE	4"	GB04000B6
GK04375WE	4 3/8"	GB04375B6
GK04500WE	4 1/2"	GB04500B6
GK05000WE	5"	GB05000B6
GK05375WE	5 3/8"	GB05375B6
GK05437WE	5 7/16"	GB05437B6
GK05500WE	5 1/2"	GB05500B6
GK06000WE	6"	GB06000B6
GK06500WE	6 1/2"	GB06500B6
GK07500WE	7 1/2"	GB07500B6
GK08500WE	8 1/2"	GB08500B6
GK09500WE	9 1/2"	GB09500B6
GK10625WE	10 3/8"	GB10625B6
GK12625WE	12 3/8"	GB12625B6

BORE-MAX HYDRAULIC PACKING KITS

Each hydraulic packing kit for Bore-Max consists of:

- Two (2) seals
- One (1) wiper

BORE-MAX		
Adams part no.	Piston diameter	Bearing no.*
GK04375B	4 3/8"	GB04375B25
GK05000B	5"	GB05000B25
GK05500B	5 1/2"	GB05500B25
GK06000B	6"	GB06000B25
GK06500B	6 1/2"	GB06500B25
GK07000B	7"	GB07000B25
GK07500B	7 1/2"	GB07500B25
GK08500B	8 1/2"	GB08500B25

*Bearing rings are not included with these kits; they must be ordered separately. See Bearing rings, in "Other Manufacturers" section of this catalog.

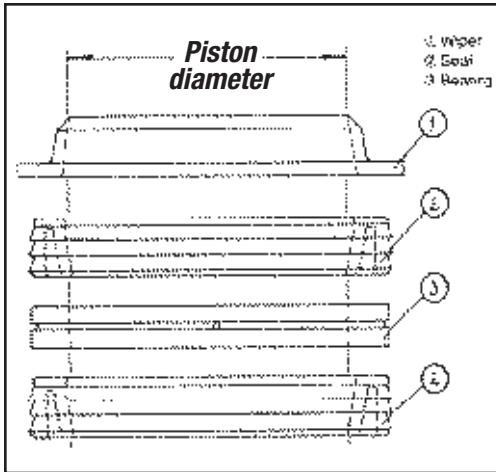

*Bearing rings are not included with these kits; they must be ordered separately. The B6-series rings are combination lantern/bearing rings; see Bearing Rings in "Other Manufacturers" section of this catalog.

CANTON	
Adams part no.	Piston diameter
TX-904-N4	3 1/2"
TX-904-P3	7"
G0-904-M7	7 1/2"
TX-904-R2	10 1/2"
TX-904-X3	3 1/2" x 5 1/2"

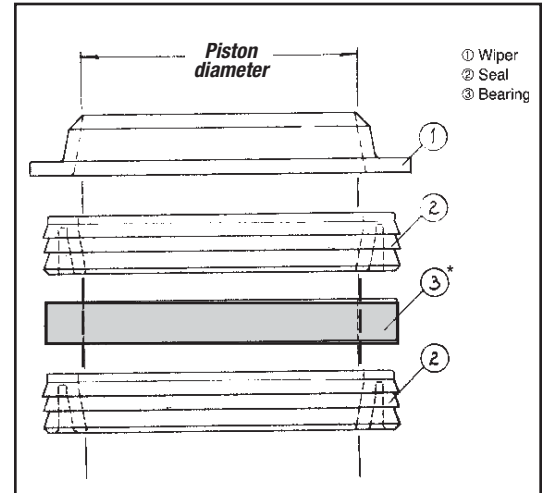

ARMOR HYDRAULIC PACKING KITS

Each hydraulic packing kit for Armor consists of:

- One (1) seal
- One (1) wiper
- One (1) O-ring

ARMOR			
Adams part no.	Piston diameter	Adams part no.	Piston diameter
GK04000A	4"	GK07562A	7 9/16"
GK04250A	4 1/4"	GK08562A	8 9/16"
GK04437A	4 7/16"	GK09562A	9 9/16"
GK05000A	5"	GK10687A	10 11/16"
GK05500A	5 1/2"	GK12687A	12 11/16"
GK06562A	6 9/16"		

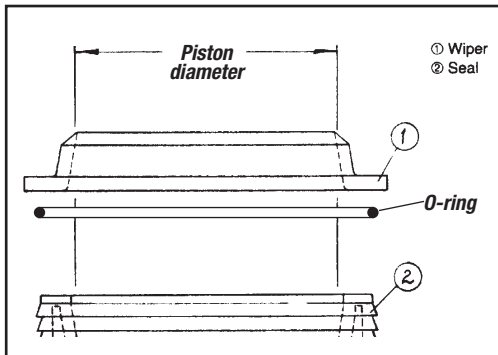

CEMCO (CORBETT) HYDRAULIC PACKING KITS

Each hydraulic packing kit for Cemco consists of:

- Two (2) seals
- One (1) wiper

CEMCO		
Adams part no.	Piston diameter	Bearing no.*
GK03500C	3 1/2"	GB03500B8
GK03750C	3 3/4"	GB03750B8
GK04000C	4"	GB04000B8
GK04375C	4 3/8"	GB04375B8
GK04437C	4 7/16"	GB04437B8
GK04500C	4 1/2"	GB04500B8
GK05000C	5"	GB05000B8
GK05437C	5 7/16"	GB05437B8
GK05500C	5 1/2"	GB05500B8
GK06000C	6"	GB06000B8
GK06500C	6 1/2"	GB06500B8
GK07000C	7"	GB07000B8
GK07500C	7 1/2"	GB07500B8
GK08000C	8"	GB08000B8
GK08500C	8 1/2"	GB08500B8
GK09000C	9"	GB09000B8
GK09500C	9 1/2"	GB09500B8
GK10000C	10"	GB10000B8
GK10500C	10 1/2"	GB10500B8
GK10625C	10 3/8"	GB10625B8
GK12500C	12 1/2"	GB12500B8
GK12625C	12 3/8"	GB12625B8

*Bearing rings are not included with these kits; they must be ordered separately. See Bearing rings, in "Other Manufacturers" section of this catalog.

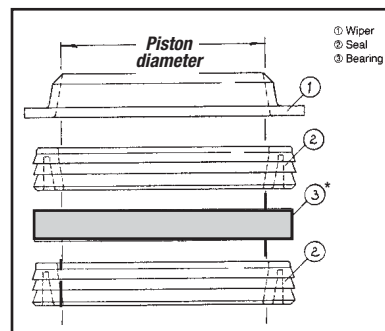

DOVER HYDRAULIC PACKING KITS

Each hydraulic packing kit for Dover consists of:

- One (1) seal
- One (1) wiper
- One (1) lantern ring

DOVER	
Adams part no.	Piston diameter
GK04375D	4 ³ / ₈ "
GK05437D	5 ⁷ / ₁₆ "
GK06500D	6 ¹ / ₂ "
GK07500D	7 ¹ / ₂ "
GK08500D	8 ¹ / ₂ "
GK09500D	9 ¹ / ₂ "
GK10625D	10 ⁵ / ₈ "
GK12625D*	12 ⁵ / ₈ "
GK03875DS	3 ⁷ / ₈ "

*Available on special order only; please allow three weeks for delivery.

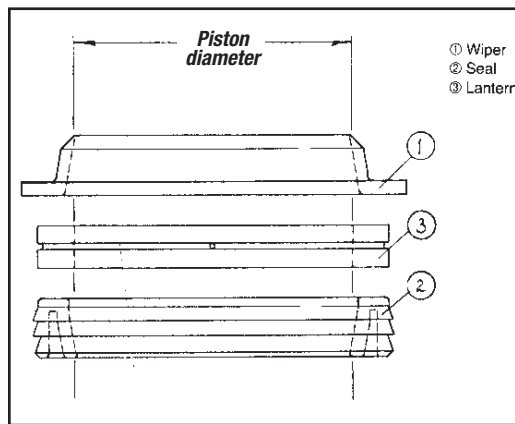

DOVER 3-S STACK PACKING FOR IVO INVERTED HYDRO HYDRAULIC PACKING KIT

Our hydraulic packing kit for Dover 3-S Stack Packing consists of:

- Three (3) seals, split
- One (1) wiper
- Three (3) lantern rings (gaskets)

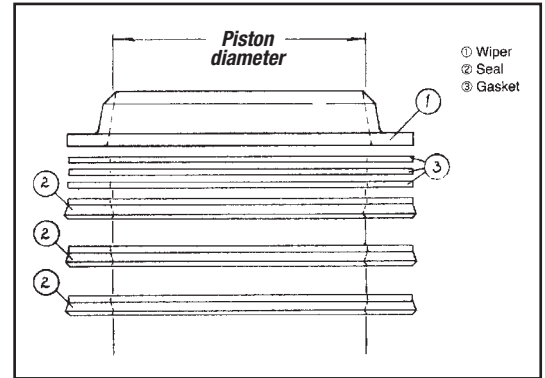

DOVER 3-S STACK PACKING

Adams part no.	Piston diameter
GK03875DSP	3 ⁷ / ₈ "

DOVER 3S*, 4S, 5S, & 6S HYDRAULIC PACKING KITS

Each hydraulic packing kit for Dover 3S, 4S, 5S, & 6S consists of:

- One (1) seal (Rotoseal)TM
- One (1) wiper



DOVER 3-S SOLID SEAL HYDRAULIC PACKING KIT

Our hydraulic packing kit for Dover 3-S Solid Seal consists of:

- One (1) seal
- One (1) wiper

DOVER 3-S SOLID SEAL	
Adams part no.	Piston diameter
GK03875DS	3 ⁷ / ₈ "

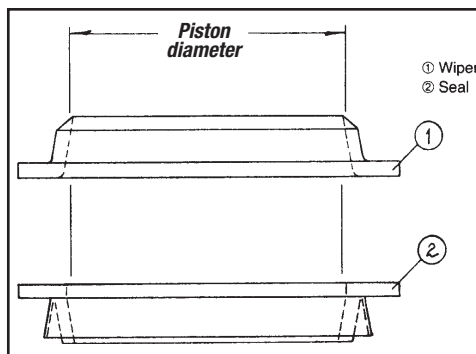
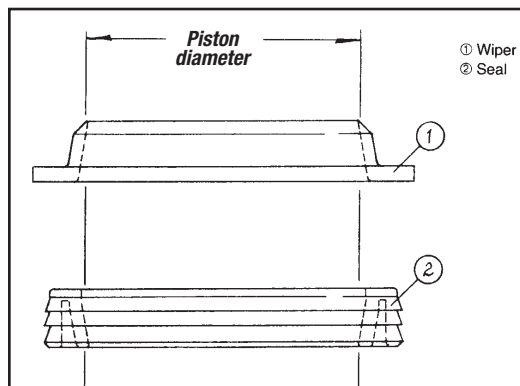

DOVER 3S, 4S, 5S, & 6S

Adams part no.	Piston diameter
GK04375DR	4 ³ / ₈ "
GK05437DR	5 ⁷ / ₁₆ "
GK06500DR	6 ¹ / ₂ "

Rotoseal — Reg TM Dover Elevator Company

HYDRAULIC PACKING

The seals and wipers listed below are top-grade Adams "pressure-balanced" packing.

Our packing works well in all elevators...but you'll notice the greatest improvement in elevators with rough start-up.

This packing can reduce break-away friction up to 35%. It also minimizes running friction and seal-related noises in all elevators, increasing the life of the seal.

Adams part no.	Type	Piston diameter	Replaces Dover part nos.
DP3000	Seal	3 ¹ / ₂ "	9787239, 28723
DP3100	Wiper	3 ¹ / ₂ "	9730349, 77034
DP4000	Seal	4 ³ / ₈ "	9787240, JB-221-1
DP4100	Wiper	4 ³ / ₈ "	9705272, JB-219-3
DP5000	Seal	5 ⁷ / ₁₆ "	9787252, JC-221-1
DP5100	Wiper	5 ⁷ / ₁₆ "	9705442, JC-219-3
DP6000	Seal	6 ¹ / ₂ "	9787264, JD221-1
DP6100	Wiper	6 ¹ / ₂ "	9705612, JD219-3

ECCO (LJ/FJ) HYDRAULIC PACKING KITS

Each hydraulic packing kit for ECCO consists of:

- Two (2) seals
- One (1) wiper
- One (1) lantern ring

ECCO	
Adams part no.	Piston diameter
GK03437EE	3 ⁷ / ₁₆ "
GK03875EE	3 ⁷ / ₈ "
GK04000EE	4"
GK04375EE	4 ³ / ₈ "
GK05000EE	5"
GK05437EE	5 ⁷ / ₁₆ "
GK06000EE	6"
GK06500EE	6 ¹ / ₂ "
GK07500EE	7 ¹ / ₂ "
GK08500EE	8 ¹ / ₂ "
GK10625EE	10 ⁵ / ₈ "
GK12625EE	12 ⁵ / ₈ "

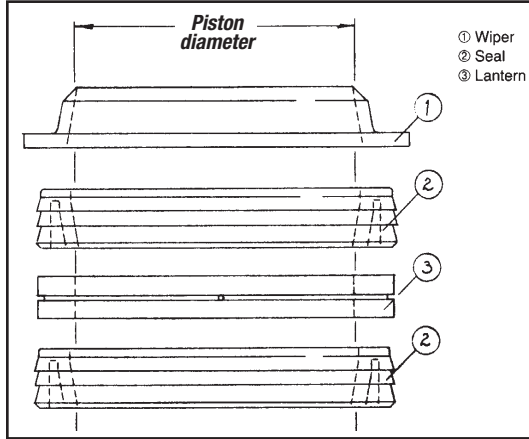

ESCO P-3/P-5/P-7 HYDRAULIC PACKING KITS

Each hydraulic packing kit for ESCO P-3/P-5/P-7 consists of:

- Two (2) seals
- One (1) wiper
- One (1) lantern ring

ESCO P-3/P-5/P-7	
Adams part no.	Piston diameter
GK04000EP	4"
GK04500EP	4 ¹ / ₂ "
GK05000EP	5"
GK05500EP	5 ¹ / ₂ "
GK06000EP	6"
GK07000EP	7"
GK08000EP	8"
GK09000EP	9"
GK10625EP	10 ⁵ / ₈ "
GK12625EP	12 ⁵ / ₈ "
GK13875EP	13 ⁷ / ₈ "

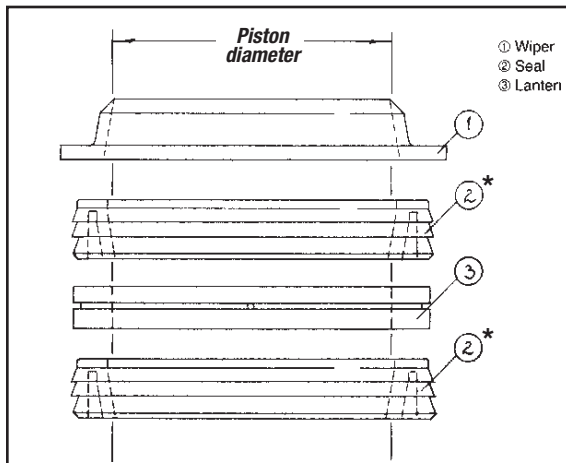

*For model P-4, invert seals.

ESCO P-6 VICTAULIC HYDRAULIC PACKING KITS

Each hydraulic packing kit for ESCO P-6

Victaulic consists of:

- One (1) seal
- One (1) wiper

ESCO P-6 VICTAULIC		
Adams part no.	Piston diameter	Bearing no.*
GK04000EPV	4"	GB04000B5
GK04500EPV	4 ¹ / ₂ "	GB04500B5
GK05000EPV	5"	GB05000B5
GK05500EPV	5 ¹ / ₂ "	GB05500B5
GK06000EPV	6"	GB06000B5
GK06500EPV	6 ¹ / ₂ "	GB06500B5
GK07000EPV	7"	GB07000B5

*Bearing rings are not included with these kits; they must be ordered separately. See Bearing rings, in "Other Manufacturers" section of this catalog.

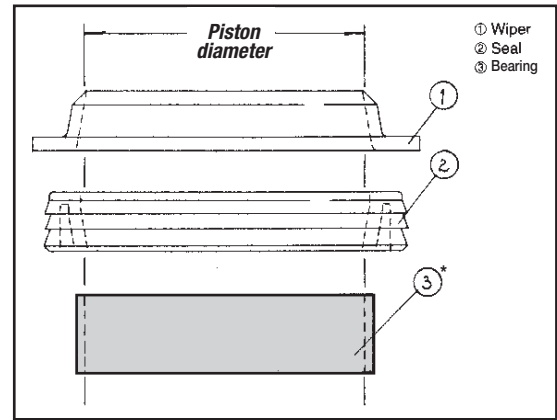

GENERAL (FLORIDA) HYDRAULIC PACKING KITS

Each hydraulic packing kit for

General (Florida) consists of:

- One (1) seal
- One (1) wiper
- One (1) bearing

GENERAL (FLORIDA)	
Adams part no.	Piston diameter
GK03437G	3 ⁷ / ₁₆ "
GK03937G	3 ¹⁵ / ₁₆ "
GK04437G	4 ⁷ / ₁₆ "
GK04500G	4 ¹ / ₂ "
GK05437G	5 ⁷ / ₁₆ "
GK05500G	5 ¹ / ₂ "
GK06437G	6 ⁷ / ₁₆ "
GK06500G	6 ¹ / ₂ "
GK07500G	7 ¹ / ₂ "
GK08500G	8 ¹ / ₂ "
GK09500G	9 ¹ / ₂ "

NOTE: Bearing rings are included with these kits.

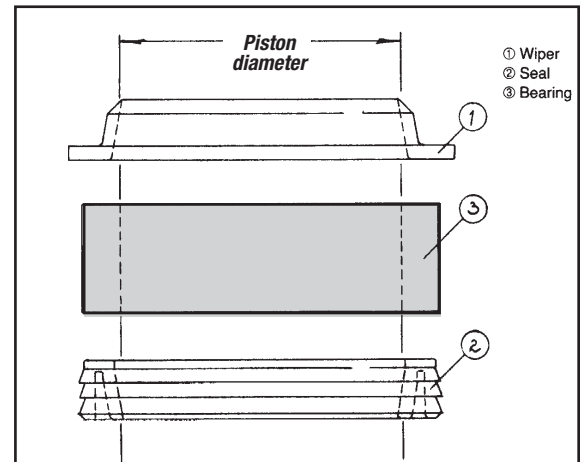

GENERAL "G" HEAD HYDRAULIC PACKING KITS

Each hydraulic packing kit for General (Florida) "G" Head consists of:

- One (1) seal
- One (1) wiper

GENERAL "G" HEAD		
Adams part no.	Piston diameter	Bearing no.*
GK03500GG	3 1/2"	GB03500B21
GK04000GG	4"	GB04000B21
GK04437GG	4 7/16"	GB04437B21
GK04500GG	4 1/2"	GB04500B21
GK05000GG	5"	GB05000B21
GK05437GG	5 7/16"	GB05437B21
GK05500GG	5 1/2"	GB05500B21
GK06437GG	6 7/16"	GB06437B21
GK06500GG	6 1/2"	GB06500B21
GK07500GG	7 1/2"	GB07500B21

*Bearing rings are not included with these kits; they must be ordered separately. See Bearing rings, in "Other Manufacturers" section of this catalog.

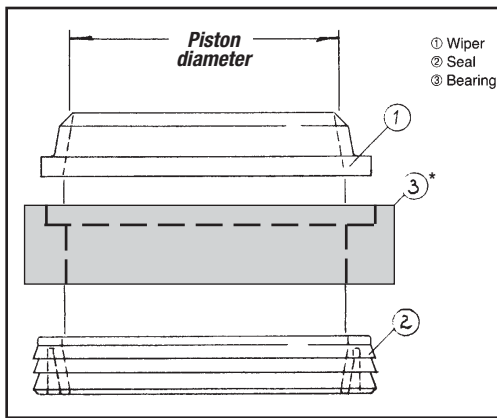

NORTHERN ELEVATOR HYDRAULIC PACKING KITS

Each hydraulic packing kit for Northern Elevator consists of:

- One (1) seal
- One (1) wiper

NORTHERN ELEVATOR	
Adams part no.	Piston diameter
GK03000N	3"
GK03500N	3 1/2"
GK04000N	4"
GK04500N	4 1/2"
GK05000N	5"
GK05500N	5 1/2"
GK06000N	6"
GK06500N	6 1/2"

*Includes one seal, one lantern, one wiper.

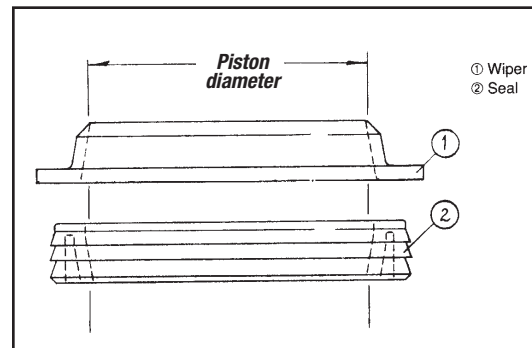

MONTGOMERY HYDRAULIC PACKING KITS

Each hydraulic packing kit for Montgomery consists of:

- Two (2) seals
- One (1) wiper
- One (1) lantern ring

MONTGOMERY	
Adams part no.	Piston diameter
GK03937M	3 15/16"
GK04375M	4 3/8"
GK04500M	4 1/2"
GK05437M	5 7/16"
GK05500M*	5 1/2"
GK05750M	5 3/4"
GK06562M	6 9/16"
GK07500M	7 1/2"
GK08562M	8 9/16"
GK09500M	9 1/2"
GK10715M	10 18/25"
GK12625M	12 5/8"

*Includes one seal, one lantern, one wiper.

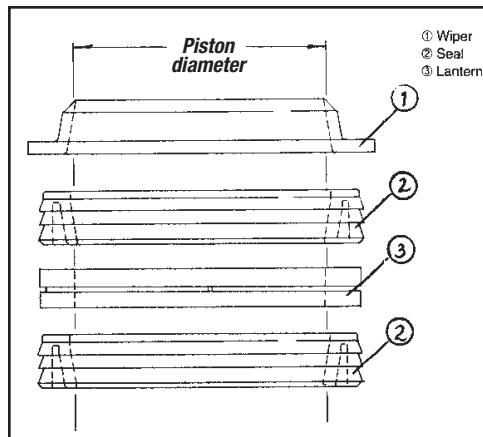

OTIS/CAST IRON HYDRAULIC PACKING KITS

Each hydraulic packing kit for Otis/Cast Iron consists of:

- Two (2) seals
- One (1) wiper
- One (1) lantern ring

OTIS/CAST IRON		
Adams part no.	Piston diameter	Bearing no.*
GK03875OC	3 7/8"	GB03875B1
GK04375OC	4 3/8"	GB04375B1
GK05437OC	5 7/16"	GB05437B1
GK06500OC	6 1/2"	GB06500B1
GK07500OC	7 1/2"	GB07500B1
GK08500OC	8 1/2"	GB08500B1
GK09500OC	9 1/2"	GB09500B1
GK10625OC	10 5/8"	GB10625B1
GK12625OC	12 5/8"	GB12625B1

*Bearing rings are not included with these kits; they must be ordered separately. See Bearing rings, in "OTIS" section of this catalog.

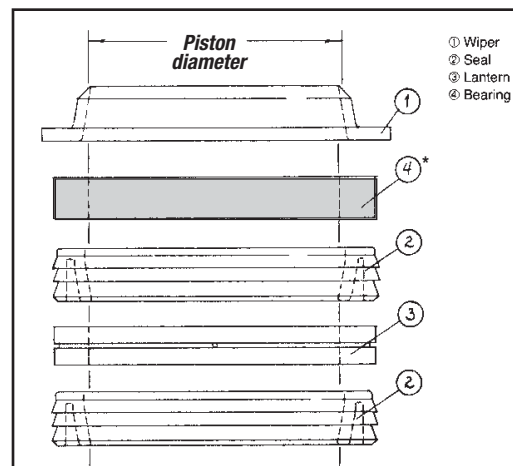

OTIS/HIGH PRESSURE HYDRAULIC PACKING KIT

Our hydraulic packing kit for Otis/High Pressure

consists of:

- One (1) seal
- One (1) wiper

OTIS/HIGH PRESSURE		
Adams part no.	Piston diameter	Bearing no.*
GK02750HP	2 3/4"	GB02750B4

*Bearing rings are not included with these kits; they must be ordered separately. See Bearing rings, in "OTIS" section of this catalog.

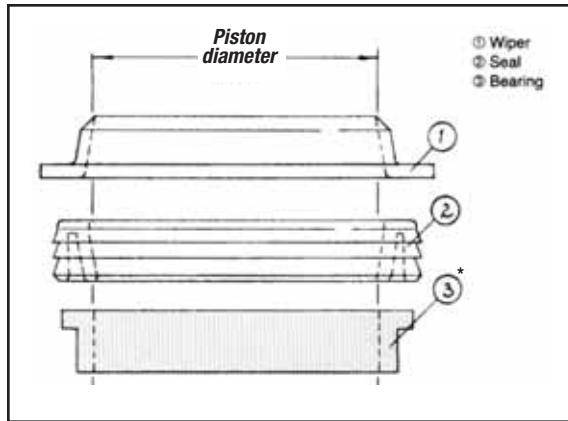

OTIS/TELESCOPIC HYDRAULIC PACKING KITS

Each hydraulic packing kit for Otis/Telescopic consists of:

- Three (3) seals, graduated sizes
- Two (2) wipers, graduated sizes

OTIS/TELESCOPIC	
Adams part no.	Otis series no.
GK1500OT	1500
GK2000OT	2000
GK2500OT	2500
GK4000OT	4000

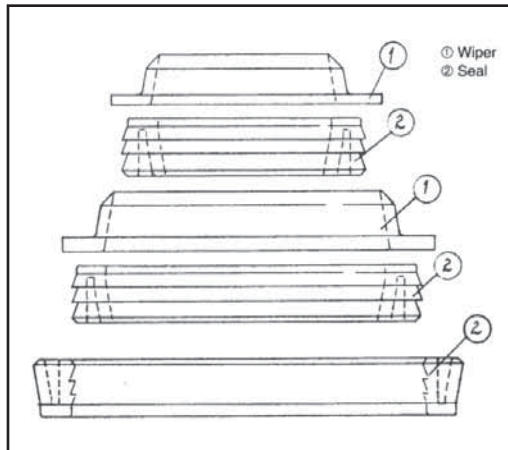

OTIS/WELDED HEAD HYDRAULIC PACKING KITS

Each hydraulic packing kit for Otis/Welded Head consists of:

- Two (2) seals
- One (1) wiper
- One (1) lantern ring

OTIS/WELDED HEAD			
Adams part no.	Piston diameter		Bearing no.*
	Actual	Otis desig.	
GK04375OW	4 3/8"	4 1/2"	GB04375B4
GK04875OW	4 7/8"	5"	GB04875B4
GK05437OW	5 7/16"	5 1/2"	GB05437B4
GK06500OW	6 1/2"	6 1/2"	GB06500B4

*Bearing rings are not included with these kits; they must be ordered separately. See Bearing rings, in "OTIS" section of this catalog.

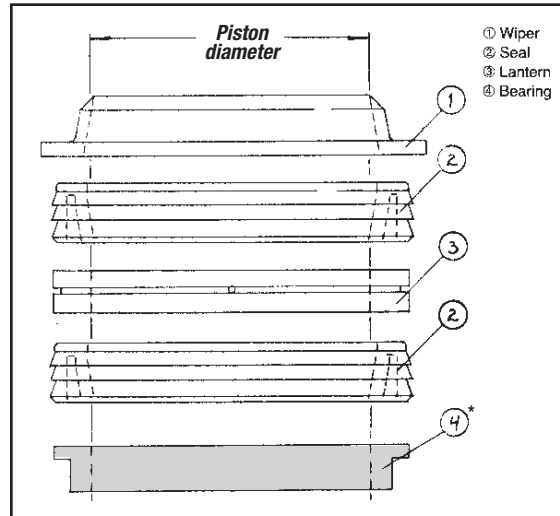

SOUTHEASTERN (SH-4/5, SF-5, SE-6) HYDRAULIC PACKING KITS

Each hydraulic packing kit for Southeastern consists of:

- One (1) seal
- One (1) wiper

SOUTHEASTERN			
Adams part no.	Replaces Southeastern	Piston diameter	Bearing no.*
GK04375OW	4 3/8"	4 1/2"	GB04375B4
GK04875OW	4 7/8"	5"	GB04875B4
GK05437OW	5 7/16"	5 1/2"	GB05437B4
GK06500OW	6 1/2"	6 1/2"	GB06500B4

*Bearing rings are not included with these kits; they must be ordered separately on page 398.

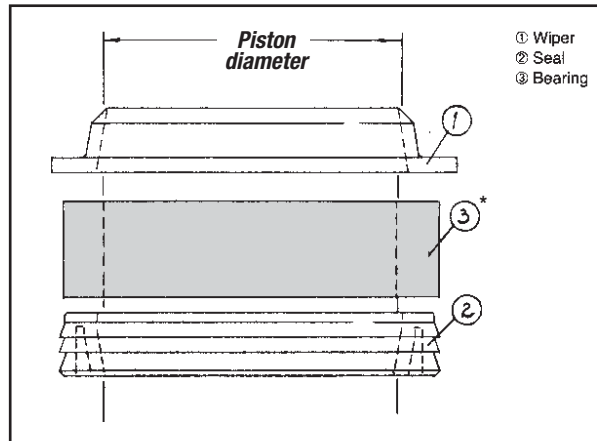

SOUTHEASTERN (SE-7/8/9/12, SH-10) HYDRAULIC PACKING KITS

Each hydraulic packing kit for Southeastern consists of:

- Two (2) seals
- One (1) wiper
- One (1) lantern ring

SOUTHEASTERN		
Adams part no.	Replaces Southeastern	Piston diameter
GK07500S	SE-7	7 1/2"
GK08500S	SE-8	8 1/2"
GK09500S	SE-9	9 1/2"
GK10625S	SH-10	10 5/8"
GK12625S	SE-12	12 5/8"

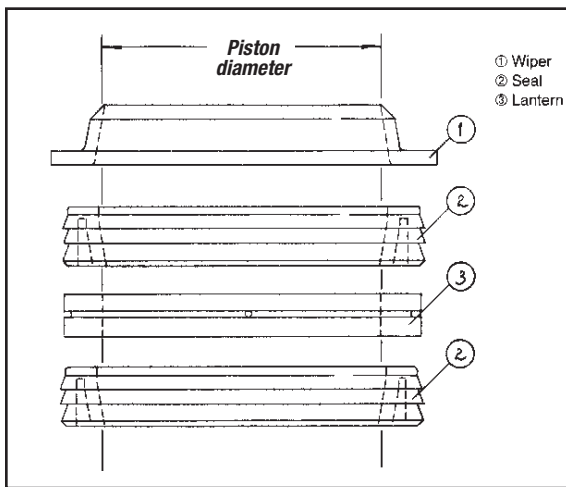

U.S. ELEVATOR/SPLIT SEAL STACK PACKING HYDRAULIC PACKING KITS

Each hydraulic packing kit for U.S. Elevator consists of:

- Three (3) seals, split
- One (1) wiper
- One (1) lantern ring, split

U.S./SPLIT SEAL	
Adams part no.	Piston diameter
GK04000USP	4"
GK04500USP	4 1/2"
GK05000USP	5"
GK05500USP	5 1/2"
GK06000USP	6"
GK06500USP	6 1/2"
GK07000USP	7"
GK07500USP	7 1/2"
GK08000USP	8"
GK09000USP	9"
GK10625USP	10 5/8"
GK12625USP	12 5/8"

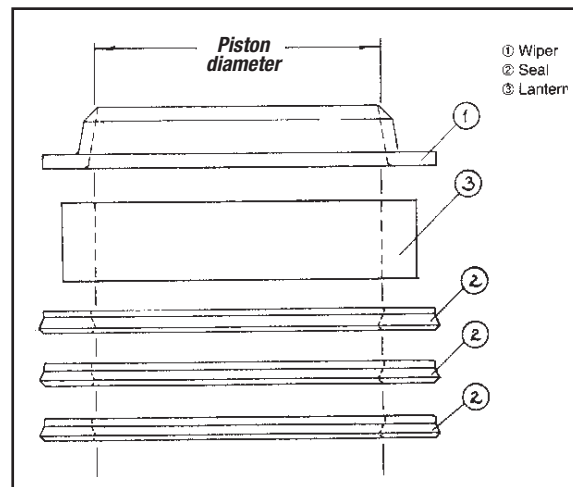

U.S. ELEVATOR/MT HEAD HYDRAULIC PACKING KITS

Each hydraulic packing kit for U.S. Elevator consists of:

- Two (2) seals
- One (1) wiper

U.S./MT HEAD		
Adams part no.	U.S. Elevator part no.	Piston diameter
GK04000UMT	MT 4	4"
GK04500UMT	MT 4 1/2	4 1/2"
GK05000UMT	MT 5	5"
GK05500UMT	MT 5 1/2	5 1/2"
GK06000UMT	MT 6	6"
GK06500UMT	MT 6 1/2	6 1/2"
GK07000UMT	MT 7	7"
GK08000UMT	MT 8	8"

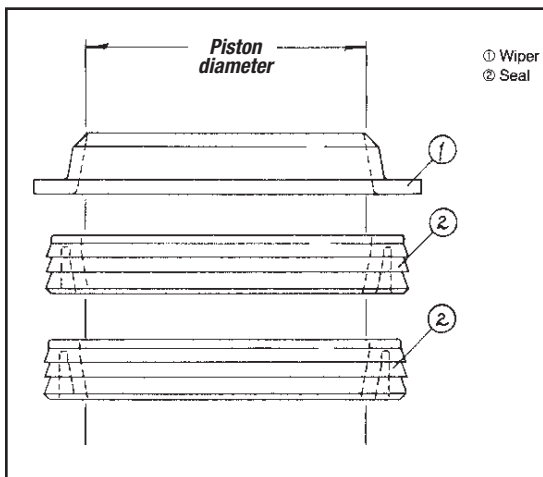

WESTINGHOUSE HYDRAULIC PACKING KITS

Each hydraulic packing kit for Westinghouse consists of:

- Two (2) seals

WESTINGHOUSE	
Adams part no.	Piston diameter
GK03500W	3 1/2"
GK03750W	3 3/4"
GK04000W	4"
GK04500W	4 1/2"
GK05500W	5 1/2"
GK06000W	6"
GK06500W	6 1/2"
GK07000W	7"
GK08000W	8"

