

THE COPY

2

AD-A219 789

REPORT DOCUMENTATION PAGE			Form Approved OMB No. 0704-0188	
Public reporting burden for this collection of information is estimated to average 1 hour per response, including the time for reviewing instructions, searching existing data sources, gathering and maintaining the data needed, and completing and reviewing the collection of information. Send comments regarding this burden estimate or any other aspect of this collection of information, including suggestions for reducing this burden, to Washington Headquarters Services, Directorate for Information Operations and Reports, 1215 Jefferson Davis Highway, Suite 1204, Arlington, VA 22202-4302, and to the Office of Management and Budget, Paperwork Reduction Project (0704-0188), Washington, DC 20503.				
1. AGENCY USE ONLY (Leave blank)	2. REPORT DATE 26 February 1990	3. REPORT TYPE AND DATES COVERED Final Report, 1 Dec 86 to 30 Nov 89		
4. TITLE AND SUBTITLE NUMERICAL CONFORMAL MAPPING AND APPLICATIONS			5. FUNDING NUMBERS AFOSR87-0102 61102F 2304/A3	
6. AUTHOR(S) Lloyd N. Trefethen				
7. PERFORMING ORGANIZATION NAME(S) AND ADDRESS(ES) Department of Mathematics Massachusetts Institute of Technology Cambridge, MA 02139			8. PERFORMING ORGANIZATION REPORT NUMBER APOSR-TR-90-0356	
9. SPONSORING/MONITORING AGENCY NAME(S) AND ADDRESS(ES) AFOSR/NM Building 410 Bolling AFB, DC 20332-6448			10. SPONSORING/MONITORING AGENCY REPORT NUMBER afosr-87-0102	
11. SUPPLEMENTARY NOTES				
12a. DISTRIBUTION/AVAILABILITY STATEMENT Approved for public release; distribution unlimited.			12b. DISTRIBUTION CODE	
13. ABSTRACT (Maximum 200 words) During the period covered by the grant, ten papers were written. Titles include "Error Bounds for Newton Refinement of Solutions to Algebraic Riccati Equations", "Computable Bounds for the Sensitivity of Algebraic Riccati Equations", and "Estimating the Distance to the Nearest Uncontrollable Pair through the Algebraic Riccati Equation". (KR)				
14. SUBJECT TERMS			15. NUMBER OF PAGES 18	
			16. PRICE CODE	
17. SECURITY CLASSIFICATION OF REPORT UNCLASSIFIED	18. SECURITY CLASSIFICATION OF THIS PAGE UNCLASSIFIED	19. SECURITY CLASSIFICATION OF ABSTRACT UNCLASSIFIED	20. LIMITATION OF ABSTRACT SAR	

DTIC ELECTE
MAR 28 1990
S E D

Final Technical Report

“Numerical Conformal Mapping and Applications”

AFOSR-87-0102
12/1/86–11/30/89

Lloyd N. Trefethen
Associate Professor of Applied Mathematics
Department of Mathematics
Massachusetts Institute of Technology

26 February 1990

Summary

This grant supported three years of research by Prof. Trefethen and several graduate students, including the thesis research of Louis Howell (PhD January 1990, M.I.T.). Progress was made in the following areas:

Algorithms for numerical conformal mapping

- Development of an algorithm for computing ideal 2D jet flows
- Development of an algorithm for mapping highly elongated polygons
- Comparison of quadrature methods in numerical conformal mapping
- Proof of divergence of existing Schwarz-Christoffel algorithms
- Improvement of algorithms for mapping circular polygons
- Derivation of a formula for mapping highly elongated circular polygons
- Review of “Schwarz-Christoffel Mapping in the 1980’s”
- Release of second edition of *SCPACK User’s Guide*

Applications of complex analysis in scientific computing

- Comparison of matrix iterative algorithms based on complex approximation
- Discovery that eigenvalue-based algorithms are unreliable
- Analysis of spectra and pseudo-spectra of Toeplitz matrices
- Development of a new hybrid algorithm for nonsymmetric matrix iterations
- Development of a Lax-stability criterion based on complex stability regions
- Development of algorithms for polynomial interpolation and least-squares

Contents

- Summary, 1
- Contents, 2
1. Introduction, 3
 2. History of grant AFOSR-87-0102, 4
 3. Personnel, 4
 4. Reports and publications, 5
 5. Technical results: algorithms for numerical conformal mapping, 6
 - 5.1. An algorithm for computing ideal 2D jet flows, 6
 - 5.2. An algorithm for mapping highly elongated polygons, 7
 - 5.3. Quadrature methods in numerical conformal mapping, 8
 - 5.4. Divergence of Schwarz-Christoffel algorithms, 9
 - 5.5. Algorithms for mapping circular polygons, 10
 - 5.6. A formula for mapping highly elongated circular polygons, 11
 - 5.7. "Schwarz-Christoffel Mapping in the 1980's," 12
 - 5.8. Second edition of *SCPACK User's Guide*, 12
 6. Technical results: applications of complex analysis in scientific computing, 13
 - 6.1. Matrix iterative algorithms based on complex approximation, 13
 - 6.2. Unreliability of eigenvalue-based algorithms, 14
 - 6.3. Spectra and pseudo-spectra of Toeplitz matrices, 15
 - 6.4. A hybrid GMRES algorithm for nonsymmetric matrix iterations, 16
 - 6.5. A Lax-stability criterion based on complex stability regions, 17
 - 6.6. Stable algorithms for polynomial interpolation and least-squares, 18

Accession For	
NTIS GRA&I	<input checked="" type="checkbox"/>
DTIC TAB	<input type="checkbox"/>
Unannounced	<input type="checkbox"/>
Justification _____	
By _____	
Distribution/	
Availability Code 5	
Dist	Avail and/or Special
A-1	



1. Introduction

Conformal mapping is as old as complex analysis, and has always been one of the branches of complex analysis most closely tied to applications. Mathematically, the problem is to find an analytic function that maps a complicated domain in the complex plane onto a simple one. The applications come about because such maps preserve solutions to Laplace's equation, as well as having other useful properties, with the result that they simplify many problems in heat conduction, electrostatics, electromagnetics, fluid mechanics, probability, and other fields.

The difficulty with conformal mapping is that except in certain special cases, the function in question cannot be determined analytically. One must resort to *numerical conformal mapping*, and in the past few decades a branch of numerical analysis has sprung up with this name. Numerical conformal mapping is not as central a topic in scientific computing as solution of differential equations, zerofinding, or linear programming, to name a few, but it persists year after year as a sideline of genuine importance.

I have been working on numerical conformal mapping since 1978, when Peter Henrici visited Stanford while I was in my second year as a graduate student. My interests have centered on ideas related to the Schwarz-Christoffel transformation, which is a formula for the conformal mapping of polygons. Like all conformal maps, Schwarz-Christoffel maps require numerical computation in all but the most trivial cases. In 1983 I produced a Fortran package called SCPACK for carrying out these computations, and in the years since then, SCPACK has become widely used.

The purpose of this grant was to support continued research in numerical conformal mapping, applications of conformal maps, and related topics. Understandably enough, the starting point of my work turned out to be the Schwarz-Christoffel transformation, and my student Louis Howell and I made substantial progress on a number of problems in this area. This work is summarized in Section 5. Then, while progress in those topics continued, the research also took another turn. One application of conformal mapping, investigated by Varga and Reichel and Tal-Ezer and others, is the derivation of coefficients for iterative methods for large matrix problems $Ax = b$. Soon after I became interested in this kind of application, I realized that the standard way of treating matrices in these problems—namely, assuming that the spectrum defines a meaningful domain for conformal mapping or other approximation methods—is inappropriate in some cases when the matrices are far from normal. And so some of the later research covered by this grant has been in a new area: *the complex analysis and numerical analysis of highly non-normal matrices*. This work is summarized in Section 6.

Most of the projects supported by this grant involved extensive computations on a network of Sun workstations, with mouse input and graphical output. I believe my early computations of this kind, in 1985, may have been the first fully interactive computations of conformal maps ever carried out anywhere. Five years later, so much has changed technologically that that statement seems astonishing.

2. History of grant AFOSR-87-0102

3/1/85 Proposal submitted
 8/26/86 Announcement of initial grant
 12/1/86 1st year starting date (\$65,117)
 5/28/87 1st year Research Progress and Forecast Report submitted
 7/22/87 Announcement of first extension
 7/??/87 1st year Research Summary submitted
 12/1/87 2nd year starting date (\$62,483)
 3/9/88 1st year Annual Technical Report submitted
 6/28/88 2nd year Research Progress and Forecast Report submitted
 9/2/88 Announcement of second extension
 12/1/88 3rd year starting date (\$66,400)
 1/18/89 2nd year Annual Technical Report submitted
 2/26/90 Final Technical Report submitted (this document)

3. Personnel

As the Principal Investigator, I was supported by this grant for three months per year, enabling me to reduce my teaching load by one-third. This had a considerable impact on my amount of time available for research on numerical conformal mapping. The work was distributed throughout the year, representing somewhere between one-third and one half of my research output.

A graduate student named Louis Howell worked with me on numerical conformal mapping throughout the three years, supported primarily by this grant. Howell finished his PhD thesis last month, with the title *Computation of Conformal Maps by Modified Schwarz-Christoffel Transformations*, and has now taken a job at Lawrence Livermore National Laboratory.

Some further work on this project has been performed with the collaboration of Noël Nachtigal, a third-year graduate student in our group, who received one month of support from this grant, and Satish Reddy, another third-year graduate student, who did not receive support from this grant.

In the final year this grant supported a two-month visit to MIT by Lothar Reichel (IBM Bergen Scientific Centre and University of Kentucky), which led to several of the results and publications described below.

4. Reports and publications

The following reports and publications were supported in whole or in part by this grant. Copies of these reports will be sent to the AFOSR under separate cover. Further papers will probably be written later by Howell concerning the topics of his thesis, [7].

- [1] F. Dias, A. R. Elcrat, and L. N. Trefethen, "Ideal jet flow in two dimensions," *Journal of Fluid Mechanics* 185 (1987), 275–288.
- [2] L. H. Howell and L. N. Trefethen, "A modified Schwarz-Christoffel transformation for highly elongated regions," *SIAM Journal on Scientific and Statistical Computing*, to appear.
- [3] L. N. Trefethen, "Approximation theory and numerical linear algebra," in J.C. Mason and M.G. Cox, eds., *Algorithms for Approximation II*, to appear.
- [4] L. N. Trefethen, "Schwarz-Christoffel Mapping in the 1980s," Numerical Analysis Report 89-1, Dept. of Mathematics, M.I.T., January 1989.
- [5] L. N. Trefethen, "SCPACK User's Guide," Numerical Analysis Report 89-2, Dept. of Mathematics, M.I.T., January 1989.
- [6] S. C. Reddy and L. N. Trefethen, "Lax-stability of fully discrete spectral methods via stability regions and pseudo-eigenvalues," in *Proc. International Conf. on Spectral and High Order Methods*, to appear.
- [7] L. H. Howell, *Computation of Conformal Maps by Modified Schwarz-Christoffel Transformations*, PhD thesis and Numerical Analysis Report 90-1, Dept. of Mathematics, M.I.T., January 1990.
- [8] N. M. Nachtigal, S. C. Reddy, and L. N. Trefethen, "How fast are nonsymmetric matrix iterations?," to be submitted to *SIAM Journal on Scientific and Statistical Computing*.
- [9] N. M. Nachtigal, L. Reichel, and L. N. Trefethen, "A hybrid GMRES algorithm for nonsymmetric matrix iterations", to be submitted to *SIAM Journal on Scientific and Statistical Computing*.
- [10] L. Reichel and L. N. Trefethen, "Eigenvalues and pseudo-eigenvalues of Toeplitz and block-Toeplitz matrices," in preparation.
- [11] L. Reichel, "Newton interpolation in Leja points," to appear in *BIT*.
- [12] L. Reichel, "Fast QR decomposition of Vandermonde-like matrices and polynomial least squares approximation," to appear in *SIAM J. Matrix Anal. Applics.*

5. Technical results: numerical conformal mapping

5.1. An algorithm for computing ideal 2D jet flows

The first topic of research supported by this grant was the computation of ideal two-dimensional free-streamline jet flows by conformal mapping (joint work with Frédéric Dias and Alan Elcrat). The mathematical formulation goes back to Helmholtz in 1868, and in certain situations, these idealized models can yield excellent predictions of fluid behavior. Potential applications include design of airfoils, hydrofoils, and propellers (analysis of cavitation), and various other hydrodynamical problems involving weirs, blades and dams.

Traditionally, problems of this kind have been solved by use of the hodograph domain, but that method requires a separate analysis of every flow geometry, the calculation of double integrals for every point of the flow, and the use of Riemann surfaces that may be intractable. A principal contribution of our work was the observation that the introduction of a modified Schwarz-Christoffel integral makes it possible to dispense with the hodograph domain and obtain a faster solution involving a single integral, with no need for separate analysis of each geometry or the use of Riemann surfaces. We have implemented the resulting algorithm in an interactive Fortran package called JET, which computes the ideal jet flow through any polygonal nozzle to arbitrary precision.

This work has been published in [1]. An example of a jet flow calculated by the new method is reproduced below. The nozzle shown is actually a polygon, with the quarter-circular lip approximated by 16 straight segments.

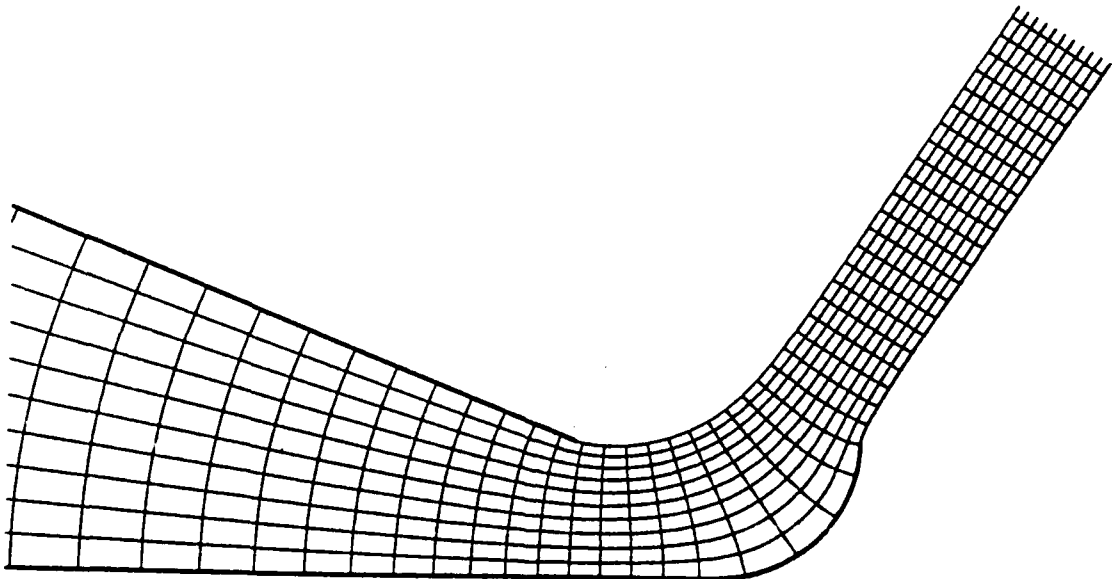

5.2. An algorithm for mapping highly elongated polygons

A long-standing problem in numerical conformal mapping has been the treatment of elongated domains. For well-understood reasons, the conformal map of, say, a disk or half-plane onto a rectangle of aspect ratio 25 is generally impossible even to represent in floating-point arithmetic, let alone to compute with. The problem lies in the mapping itself, not in the algorithm intended to compute it. Many conformal mapping algorithms run into trouble caused by this so-called "crowding phenomenon," and my own SCPACK is no exception. Unfortunately, many applications in fluid dynamics and electronics require the use of elongated geometries.

During 1987, Louis Howell and I implemented an idea for getting around this problem for the important special case of highly elongated polygons: a modified Schwarz-Christoffel formula based on the idea of mapping from an infinite strip rather than a disk or half-plane. It works very well, enabling us to map regions with aspect ratios in the tens of thousands. Our paper [2] on this subject will appear in the next issue of *SIAM Journal on Scientific and Statistical Computing*.

The figure below illustrates an elongated 23-sided polygon that has been mapped to a rectangle by the new method, to essentially full machine precision. (The aspect ratio of the rectangle is 156.6241139.) The curves plotted are conformal images of horizontal and vertical lines in the rectangle. This region is far beyond the capabilities of any other conformal mapping methods that I know of.

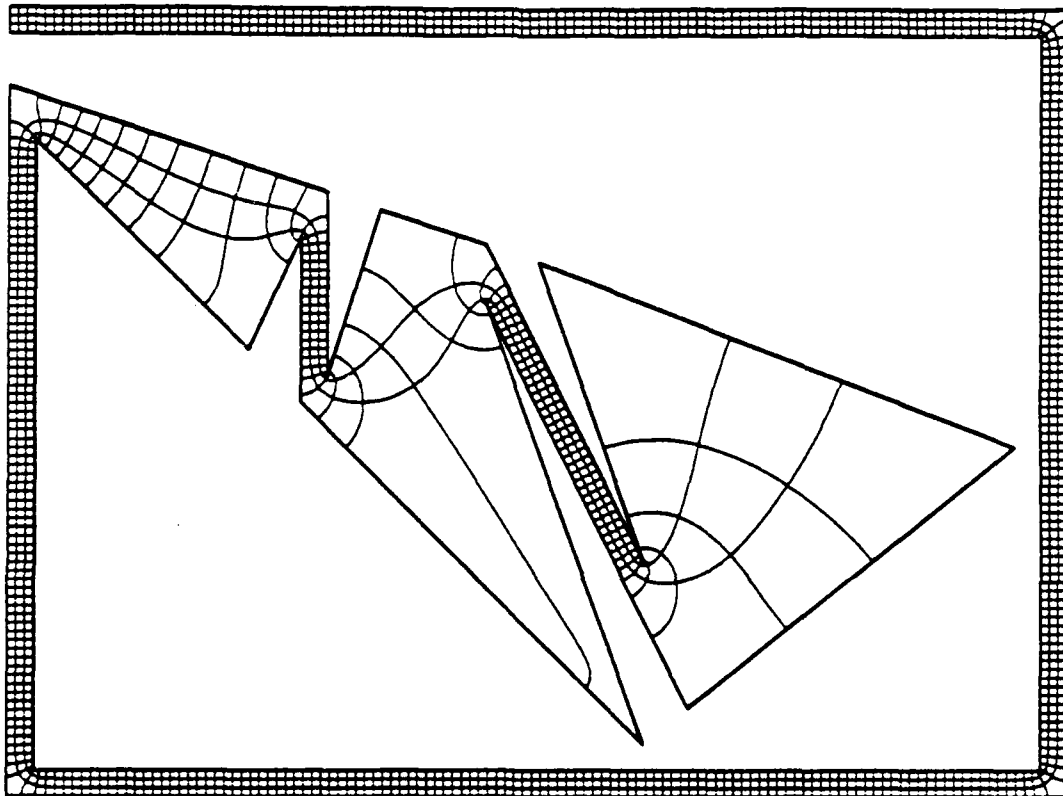

5.3. Quadrature methods in numerical conformal mapping

Successful implementation of the Schwarz-Christoffel transformation and other related methods of numerical conformal mapping depends on the rapid and reliable evaluation of integrals with endpoint singularities. Many methods for the evaluation of such integrals have been proposed over the years. Among those with a reasonable claim to be close to optimal, the leading candidates are compound Gauss-Jacobi quadrature (used in SCPACK) and various more fully adaptive methods coupled with singularity removal via subtraction (Kantorovich and Krylov) or change of variables (Dias).

These quadrature methods have been compared in the past, but not from a modern point of view. For example, a PhD thesis by E.-S. Meyer in 1979 devoted many pages to a comparison of methods for Schwarz-Christoffel integrals, but ended up rejecting Gauss-Jacobi methods on the grounds that the required coefficients are hard to obtain—which is simply not true anymore, thanks to software such as GAUSSQ by Golub and Welsch. In the past two years, therefore, Howell and I decided to carry out an extensive and more up-to-date comparison of various integration schemes for Schwarz-Christoffel problems. We believe the result is, relatively speaking, definitive.

Our conclusion is that for Schwarz-Christoffel problems, compound Gauss-Jacobi methods are faster than other integration methods by a factor of two or more. This factor can be thought of as the cost of adaptation, for the Gauss-Jacobi approach avoids adaptation by using a priori knowledge of the location of singularities.

For example, the lengths of the sides in the 10-sided polygon below can be evaluated to 10-digit accuracy by compound Gauss-Jacobi quadrature with 112 integrand evaluations. The best result we have found for a competing method is 538 integrand evaluations, achieved by a complex version of the adaptive code QUANC8 coupled with a change of variables to eliminate singularities. Lower accuracy specifications narrow the gap somewhat, but compound Gauss-Jacobi quadrature remains the winner.

These results are described in [7].

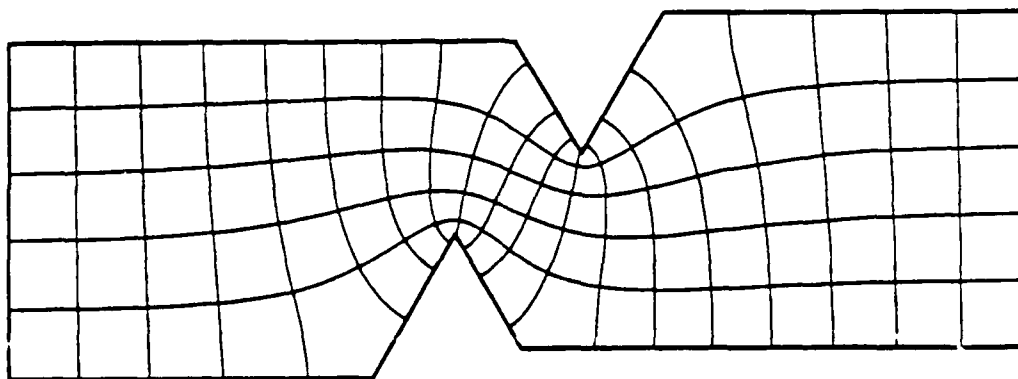

5.4. Divergence of Schwarz-Christoffel algorithms

In practice, SCPACK nearly always constructs conformal maps successfully—that is, solves the Schwarz-Christoffel *parameter problem* correctly. The same is true of the quite different algorithm for solving the parameter problem used by R. T. Davis and others. Nevertheless, theorems guaranteeing convergence of these algorithms have never been proved, and in the course of his work supported by this grant, Louis Howell discovered that there is a good reason: both algorithms diverge in some cases. These results are described in Howell's thesis, [7], and will be written up for publication later.

I will illustrate here the potential divergence of SCPACK only, since that is the more surprising result. To solve the parameter problem, SCPACK adjusts parameters iteratively until the lengths of the sides of the polygon are correct. This amounts to solving a system of nonlinear equations, and to do this, a standard piece of software is used (NS01A), which guarantees descent of an appropriate objective function at every step.

The example below, due to Howell, explains why this process cannot always converge. Suppose the initial guess is the polygon on the left and the target is the polygon on the right. To get from one polygon to the other without changing any of the angles, SCPACK will have to shorten the long slits a great deal so that they can pass around each other. In doing so, the side lengths will temporarily have to move far from their correct values. In other words there is a potential barrier between the initial guess and the target, which no descent method based on a side-length formulation can cross.

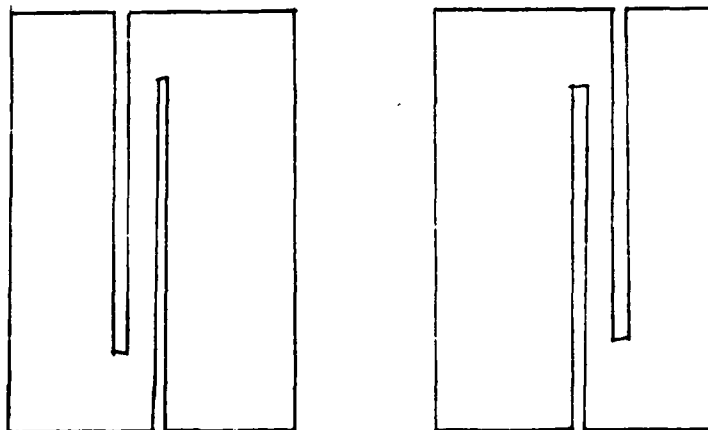

SCPACK does indeed fail, we found, when applied to examples like this. On the basis of this and other examples we have devised, we now believe that none of the existing algorithms for Schwarz-Christoffel mapping are globally convergent for all polygons.

So far, despite a number of attempts, Howell and I have not been able to devise an algorithm for Schwarz-Christoffel mapping that is guaranteed to converge in all cases. However, thanks to examples like this one and an associated theory developed in his thesis, we believe we are close to this goal.

5.5. Algorithms for mapping circular polygons

Since Schwarz in 1869, it has been known that the Schwarz-Christoffel integral can be generalized to an ordinary differential equation for the conformal mapping of *circular polygons*: planar regions bounded by straight line segments and/or circular arcs. Such regions come up surprisingly often in applications, and the set of circular polygons also has the aesthetic advantage that it is closed under Möbius transformations.

The numerical realization of this Schwarzian o.d.e. is quite another matter. At least twenty independent implementations of the Schwarz-Christoffel integral have been attempted over the years, but only once to my knowledge has the Schwarzian o.d.e. been implemented numerically in the past—by Bjørstad and Grosse (*SIAM J. Sci. Stat. Comp.*, 1987). Unfortunately, like most of the early implementations of the Schwarz-Christoffel integral itself, their attempt met with *only partial success*. The problem of mapping circular polygons proves to be highly ill-conditioned, at least in its standard formulation, with the effect that the convergence of the Bjørstad/Grosse implementation is somewhat problematical.

In his thesis [7], Louis Howell made substantial progress on this problem, without solving it completely. The details are many and cannot quickly be summarized, but here is a kind of engineering summary: the conformal mapping of circular arc polygons is now two or three times as practicable as it used to be, thanks to Howell's innovations in several parts of the problem. The definitive treatment of the circular polygon problem remains to be carried out, but I expect Howell's thesis will prove the foundation for that definitive treatment when it finally appears.

The picture below shows the mapping of a particular circular polygon to the unit disk. The interior curves are conformal images of concentric circles and radius vectors in the disk.

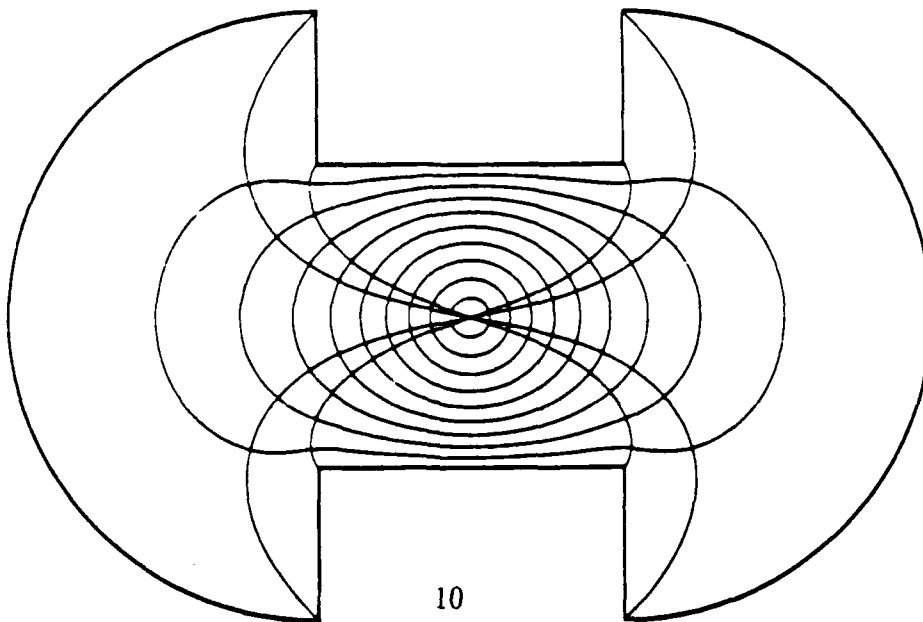

5.6. A formula for mapping highly elongated circular polygons

Section 5.2 mentioned the success we have had with an algorithm for mapping highly elongated polygons, with the motivation of combating the troublesome phenomenon of "crowding." Combining this idea with the material of Section 5.5 suggests the possibility of new algorithms for mapping highly elongated circular polygons.

In his thesis [7], Howell derives a Schwarz-Christoffel kind of formula for this purpose. To the best of our knowledge, this has not been done before. This formula will permit the mapping of domains like the one sketched below, which could certainly not be handled by the standard Schwarzian o.d.e. in floating-point arithmetic. We have not yet implemented this idea numerically.

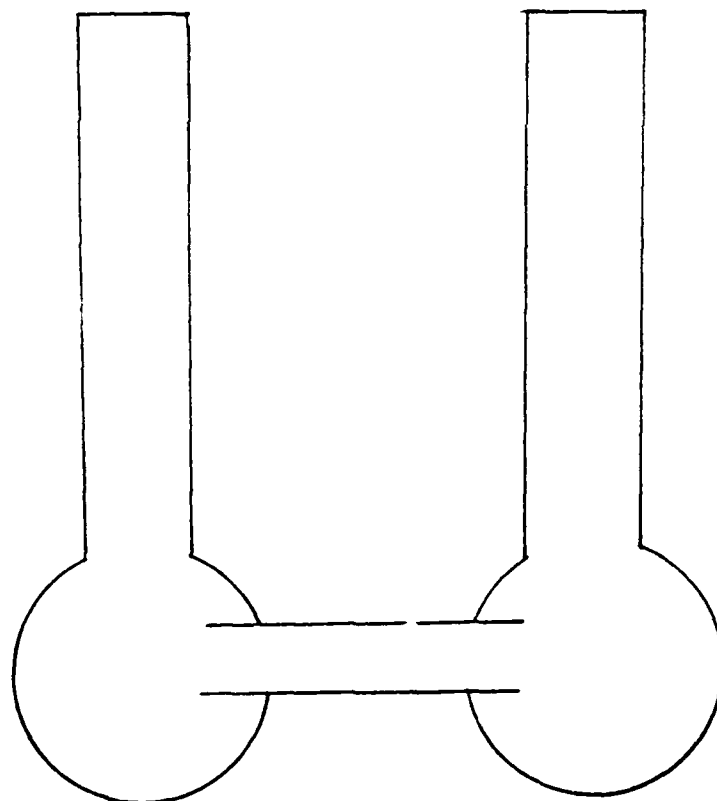

5.7. "Schwarz-Christoffel Mapping in the 1980's"

I have not made much progress towards completing the book I envision entitled *Schwarz-Christoffel Maps*. In January of 1989, however, I delivered an invited talk at the the Complex Analysis session of the American Mathematical Society meeting in Phoenix on "Schwarz-Christoffel Mapping in the 1980's," and out of that talk developed a collection of annotated transparencies, [4], which comes surprisingly close to a sketch of my eventual book—of course, with the details missing. This is not a paper for publication, but I have circulated it widely as a technical report, and I think it is the most comprehensive survey in existence of modern applications of Schwarz-Christoffel maps.

5.8. Second edition of *SCPACK User's Guide*

The first *SCPACK User's Guide* was released as an ICASE Internal Report in 1983. *SCPACK* has proved surprisingly durable since then, but its *User's Guide* came to seem increasingly old-fashioned. In January of 1989 I updated the *User's Guide* in a second edition, [5], circulated as an MIT Numerical Analysis Report, and this is now the standard reference for users of *SCPACK*.

6. Technical results: applications of complex analysis in scientific computing

6.1. Matrix iterative algorithms based on complex approximation

Since the 1950s, connections have been seen between complex analysis and the convergence of iterative algorithms for solving large systems of equations $Ax = b$. Midway through the course of the research supported by this grant, I became interested in these problems because of the possibility of using numerical conformal maps to calculate coefficients for such iterations. For example, suppose the spectrum of a matrix A is known to lie in the region Ω below. Then parameters for an effective matrix iteration can be derived via polynomial interpolation of the function z^{-1} in *Fejér points* along the boundary of Ω —the images of roots of unity under a conformal map $f(z)$ of the exterior of the unit disk onto the exterior of Ω . The figure shows 64 such Fejér points, computed with a version of SCPACK modified to map exteriors of polygons.

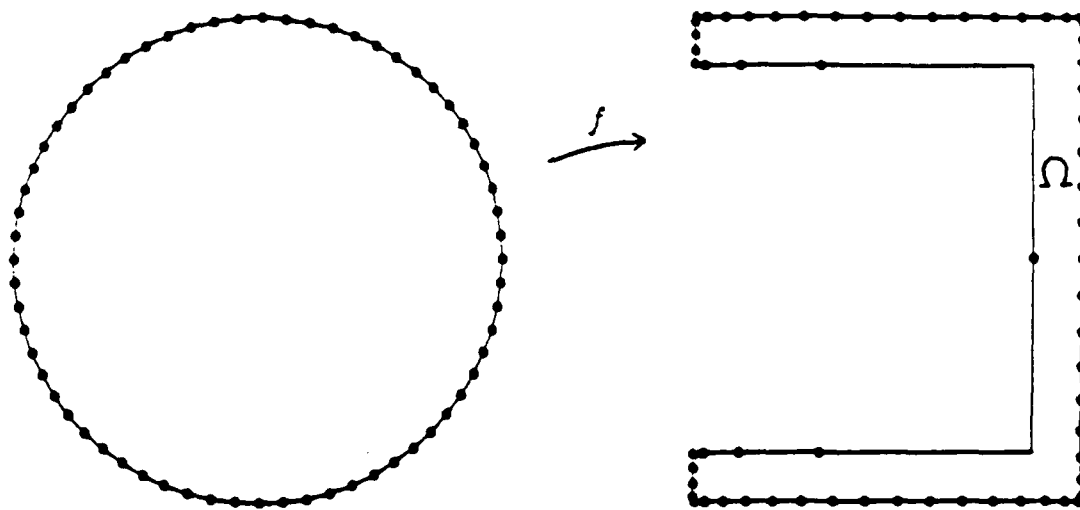

My interest in examples like this led ultimately to research supported by this grant in several directions. The first was the preparation of the report [3], which is a summary of various connections, both old and new, between matrix iterations and real and complex approximation theory. The second has been the report [8], which to the best of my knowledge is the first systematic attempt to assess and compare the convergence properties of the leading parameter-free matrix iterations for nonsymmetric matrix problems. The iterations investigated in [8] are known as CGNR, GMRES, and CGS. A point we emphasize in this paper is that the convergence of CGNR depends on the singular values of A , while the convergence of GMRES and CGS depends on the eigenvalues—assuming A happens to be normal (i.e., having orthogonal eigenvectors) or close to normal.

6.2. Unreliability of eigenvalue-based algorithms

The most interesting outgrowth of the work just described, however, was the discovery that it is a mistake to pay too much attention to the eigenvalues of a matrix if it is far from normal. In particular, the standard practice of basing algorithms on eigenvalues or estimates of eigenvalues is a dangerous one. When a matrix is far from normal, its eigenvectors may form so ill-conditioned a basis that the eigenvalues have negligible importance for practical computations. What matter more are what I call the *pseudo-eigenvalues*: those numbers λ with the property that λ is an eigenvalue of $A + E$ for some perturbation matrix E with $\|E\| \leq \epsilon$.

For example, let A be the 200×200 upper triangular Toeplitz matrix whose first row is $(1, 3/4, 3/8, 3/16, \dots)$. The spectrum of A is just the singleton $\{1\}$, which might suggest a matrix iteration based on polynomials of the form $(1 - z)^n$. However, for small ϵ , the ϵ -pseudo-spectrum is approximately the disk $|z - 3/2| \leq 1$, which suggests the quite different iteration based on $(1 - \frac{2}{3}z)^n$. The figure below shows that the first iteration leads to geometric divergence, while the second leads to geometric convergence down to the level of machine epsilon.

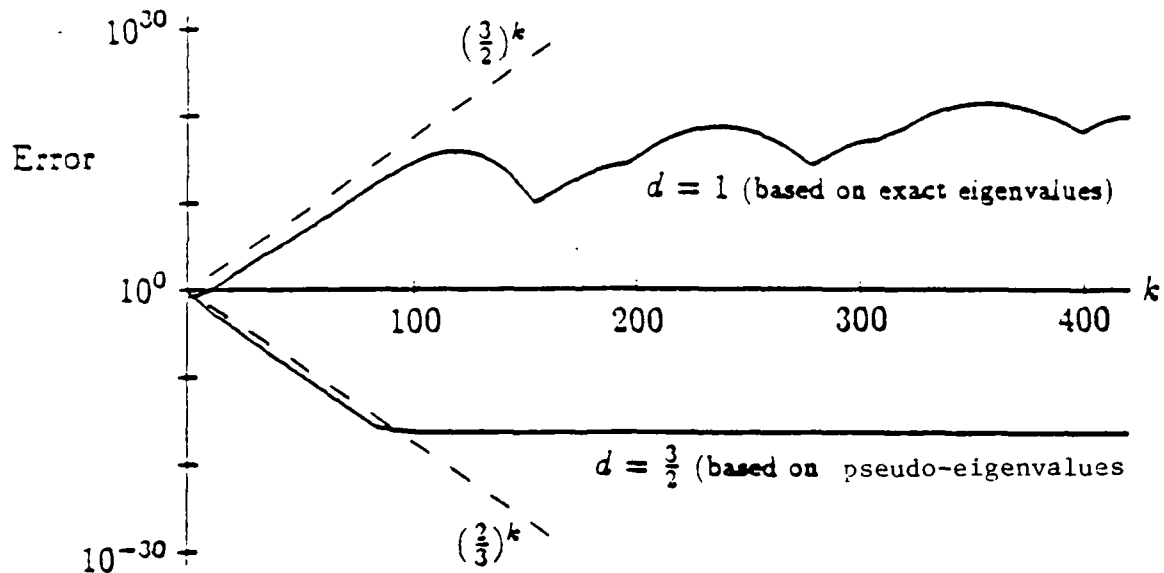

This example is artificial, but matrices equally far from normal arise in many applications—for example in Gauss-Seidel and SOR iterations, in the modeling of convection-diffusion problems, and in the solution of differential equations by spectral methods. In all of these situations and in others, our work shows that methods of complex analysis may be useful, but only if they are based on a set of pseudo-eigenvalues rather than the set of exact eigenvalues. These observations are being published in [3] and [8]. In addition, I plan quite a bit of further work in this area.

6.3. Spectra and pseudo-spectra of Toeplitz matrices

The example on the last page illustrated that the spectrum of a Toeplitz matrix may be very different from its pseudo-spectrum, and that the latter may matter more in practice.* Toeplitz matrices arise in many applications in differential equations, integral equations, spline approximation, signal processing, and other fields. During Lothar Reichel's two-month visit to MIT in 1989, supported by this grant, he and I found that Toeplitz matrices provide an interesting family of matrices with which to study the behavior of pseudo-eigenvalues. For example, consider the 100×100 Toeplitz matrix with 1 on the super-diagonal, 1 on the sub-sub-diagonal, and 0 elsewhere. The solid dots in the figure below, lying along three straight spikes, represent the spectrum of this matrix. The circles, however, show what happens to the eigenvalues when random perturbations of size $\epsilon = 10^{-4}$ are added to the matrix elements. These are examples of ϵ -pseudo-eigenvalues for a particular value of ϵ , and in any computation involving a tolerance of this order, such pseudo-eigenvalues will probably have more practical significance than the exact ones.

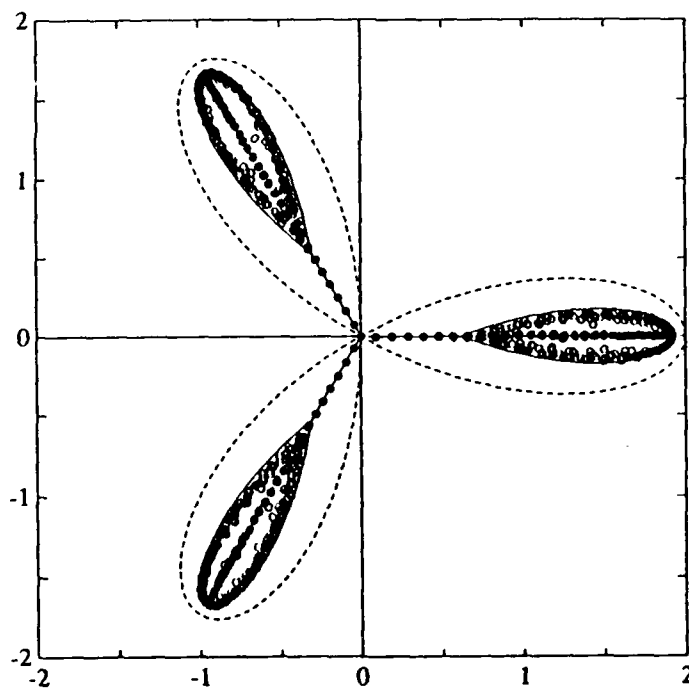

Reichel and I are preparing a paper, [10], containing a number of theorems and examples on this subject of spectra and pseudo-spectra of Toeplitz matrices. The solid curves in the figure above show the estimate for the pseudo-spectrum derived in this paper, and the dashed curves show what happens in the limit $N \rightarrow \infty$, where we get the spectrum of the associated Toeplitz operator.

*A Toeplitz matrix is one that has constant entries along diagonals.

6.4. A hybrid GMRES algorithm for nonsymmetric matrix iterations

Another outgrowth of our new approach to eigenvalues has been a new hybrid iterative algorithm for large nonsymmetric systems of equations $Ax = b$. This is joint work with Reichel and my student Noël Nachtigal. In investigating existing hybrid algorithms, which are generally based on estimating eigenvalues by the so-called Arnoldi process, we found that breakdown and divergence were possible because of the same unreliability of the use of eigenvalues discussed in Section 6.2. A different approach based on GMRES rather than Arnoldi, avoiding eigenvalues entirely, turns out to be better both theoretically and in practice. We are convinced that this is the most reliable and also the most natural hybrid iterative algorithm yet developed.

For illustration, the figure below shows the performance of our algorithm when applied to a Toeplitz matrix studied in a paper by Joe Grcar, with subdiagonal entry -1 and elements 1 on the main diagonal and the first three superdiagonals. The dimension is $N = 1000$, and the figure shows the error as a function of work for restarted GMRES and our hybrid GMRES. The hybrid algorithm is the clear winner.

This work will be published in [9].

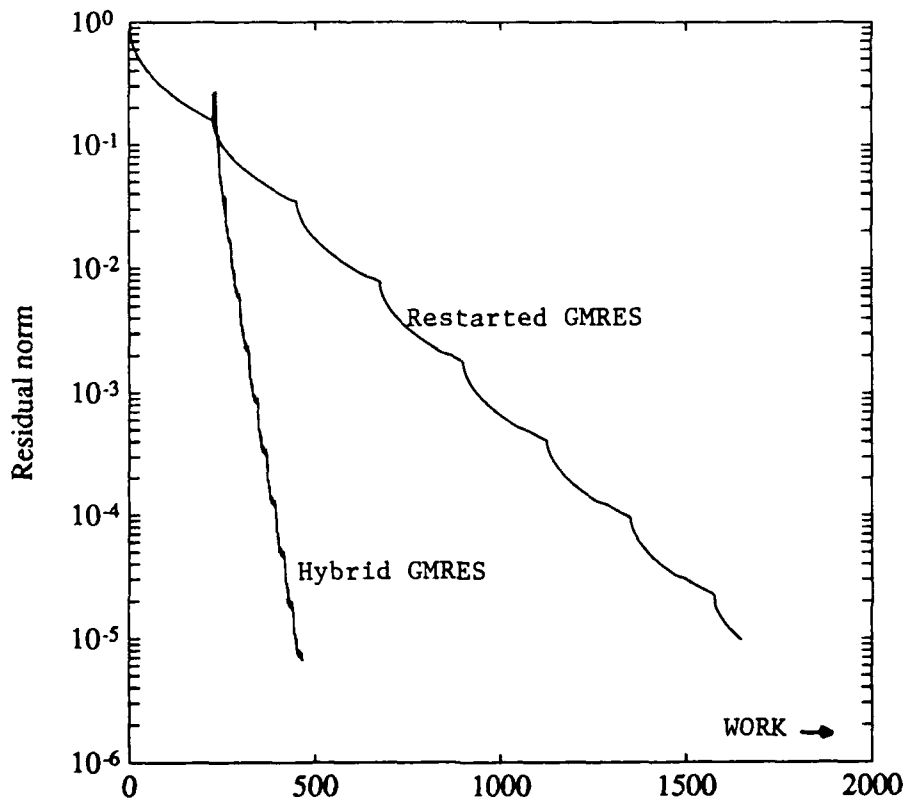

6.5. A Lax-stability criterion based on complex stability regions

Another area where complex analysis appears in numerical analysis is in the idea of *stability regions* for determining stability of discretizations of ordinary or partial differential equations. In particular, suppose a time-dependent partial differential equation is discretized in space by finite differences, finite elements, or spectral methods, then discretized in time by some o.d.e. formula such as an Adams-Bashforth or Runge-Kutta formula. This kind of separation of space and time discretizations is called the *Method of Lines*. Will the result be stable? The conventional wisdom is that to test for stability, one should test whether the eigenvalues of the spatial discretization operator lie in the stability region for the time-stepping formula. It has long been recognized, however, that this condition is necessary but not sufficient for stability.

My student Satish Reddy and I have found that the proper way to analyze such problems is once again to replace eigenvalues by pseudo-eigenvalues. In [6] and in another paper to follow, we prove theorems to the following effect:

Theorem. *A method of lines discretization is stable if and only if all the ϵ -pseudo-eigenvalues lie within a distance $O(\epsilon) + O(\Delta t)$ of the stability region as $\epsilon \rightarrow 0$ and $\Delta t \rightarrow 0$.*

In other words, roughly speaking, the old necessary conditions become necessary and sufficient, if eigenvalues are replaced by pseudo-eigenvalues.

These distinctions have important consequences for practical computations. For example, the picture below shows a solution of $u_t = u_x$ on $[-1, 1]$ by a Legendre spectral collocation method. Because the time step is too large, an instability has appeared at the boundary. According to eigenvalue analysis, one would have expected this computation to be stable, but the pseudo-eigenvalues tell otherwise.

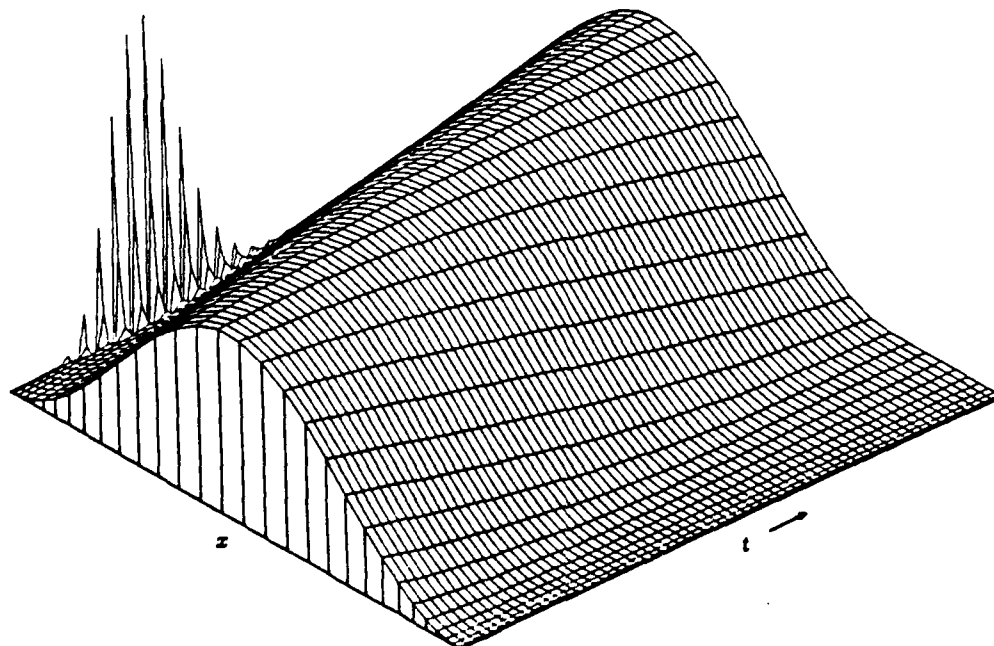

6.6. Stable algorithms for polynomial interpolation and least-squares

Finally, I will briefly mention the papers [11] and [12] by Lothar Reichel, which were completed during his visit to MIT supported by this grant. Both concern new and more stable algorithms, based on methods of complex analysis, for problems of polynomial approximation. In [11], Reichel shows that whereas polynomial interpolation on a real or complex set can be highly unstable if the usual Newton interpolation formula is used, the instability largely vanishes if the interpolation points are chosen and ordered according to what is known as a *Leja sequence*. In [12], he investigates a new and more stable algorithm for determining polynomials orthogonal with respect to an inner product, which leads to a new method for QR decomposition of Vandermonde-like matrices and thence to an improved algorithm for polynomial least-squares approximation.