

REPORT OF APOLLO 13 REVIEW BOARD

NATIONAL AERONAUTICS AND SPACE ADMINISTRATION

—

.

.

—

.

.

—



NATIONAL AERONAUTICS AND SPACE ADMINISTRATION
APOLLO 13 REVIEW BOARD

June 15, 1970

The Honorable Thomas O. Paine
Administrator
National Aeronautics and Space Administration
Washington, D.C. 20546

Dear Dr. Paine:

Pursuant to your directives of April 17 and April 21, 1970, I am transmitting the final Report of the Apollo 13 Review Board.

Concurrent with this transmittal, I have recessed the Board, subject to call.

We plan to reconvene later this year when most of the remaining special tests have been completed, in order to review the results of these tests to determine whether any modifications to our findings, determinations, or recommendations are necessary. In addition, we will stand ready to reconvene at your request.

Sincerely yours,

A handwritten signature in black ink, reading "Edgar M. Cortright", is positioned below the typed name.

Edgar M. Cortright
Chairman

PREFACE

The Apollo 13 accident, which aborted man's third mission to explore the surface of the Moon, is a harsh reminder of the immense difficulty of this undertaking.

The total Apollo system of ground complexes, launch vehicle, and spacecraft constitutes the most ambitious and demanding engineering development ever undertaken by man. For these missions to succeed, both men and equipment must perform to near perfection. That this system has already resulted in two successful lunar surface explorations is a tribute to those men and women who conceived, designed, built, and flew it.

Perfection is not only difficult to achieve, but difficult to maintain. The imperfection in Apollo 13 constituted a near disaster, averted only by outstanding performance on the part of the crew and the ground control team which supported them.

The Apollo 13 Review Board was charged with the responsibilities of reviewing the circumstances surrounding the accident, of establishing the probable causes of the accident, of assessing the effectiveness of flight recovery actions, of reporting these findings, and of developing recommendations for corrective or other actions. The Board has made every effort to carry out its assignment in a thorough, objective, and impartial manner. In doing so, the Board made effective use of the failure analyses and corrective action studies carried out by the Manned Spacecraft Center and was very impressed with the dedication and objectivity of this effort.

The Board feels that the nature of the Apollo 13 equipment failure holds important lessons which, when applied to future missions, will contribute to the safety and effectiveness of manned space flight.

This page left blank intentionally.

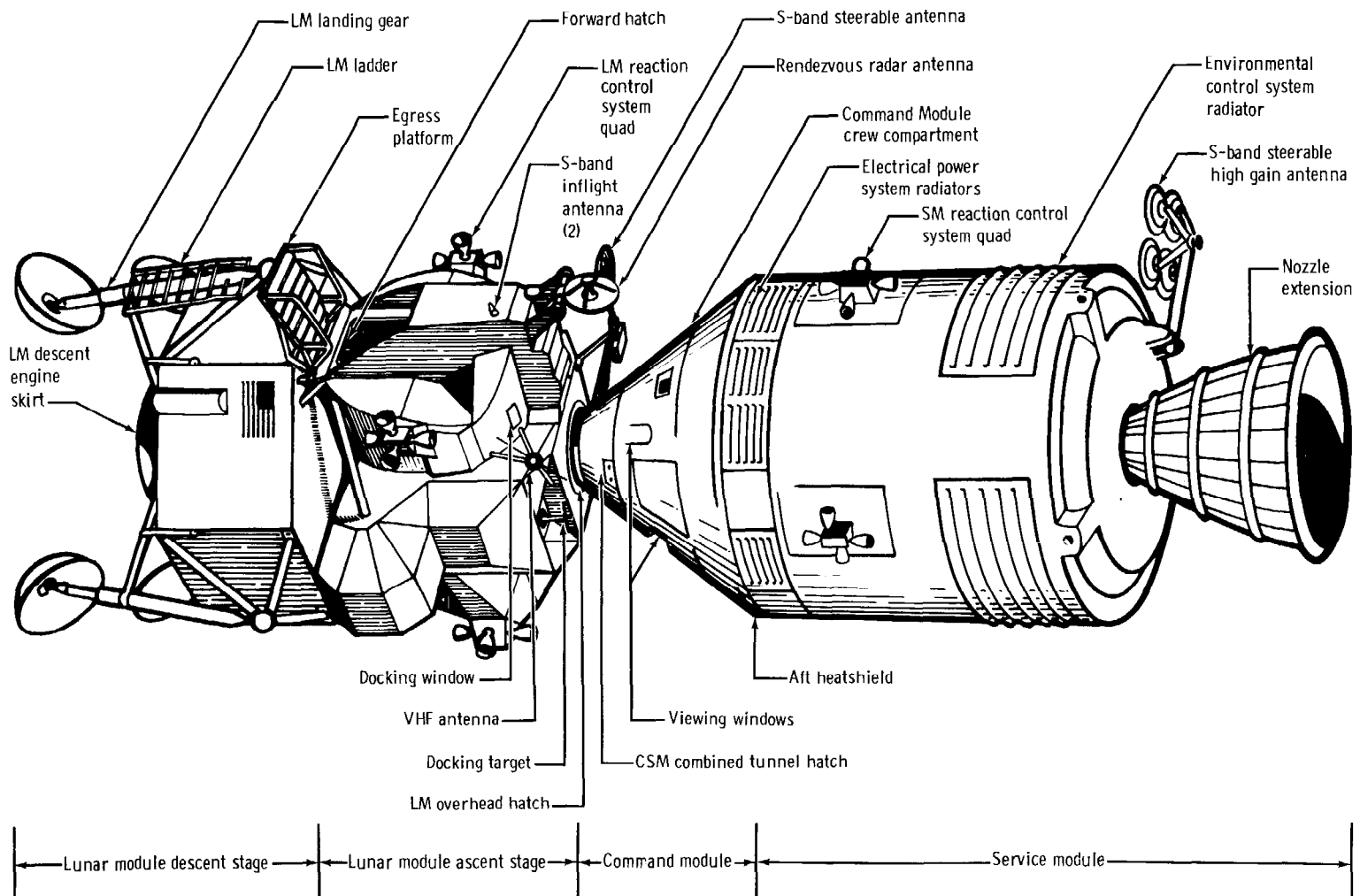

Apollo 13 space vehicle configuration.

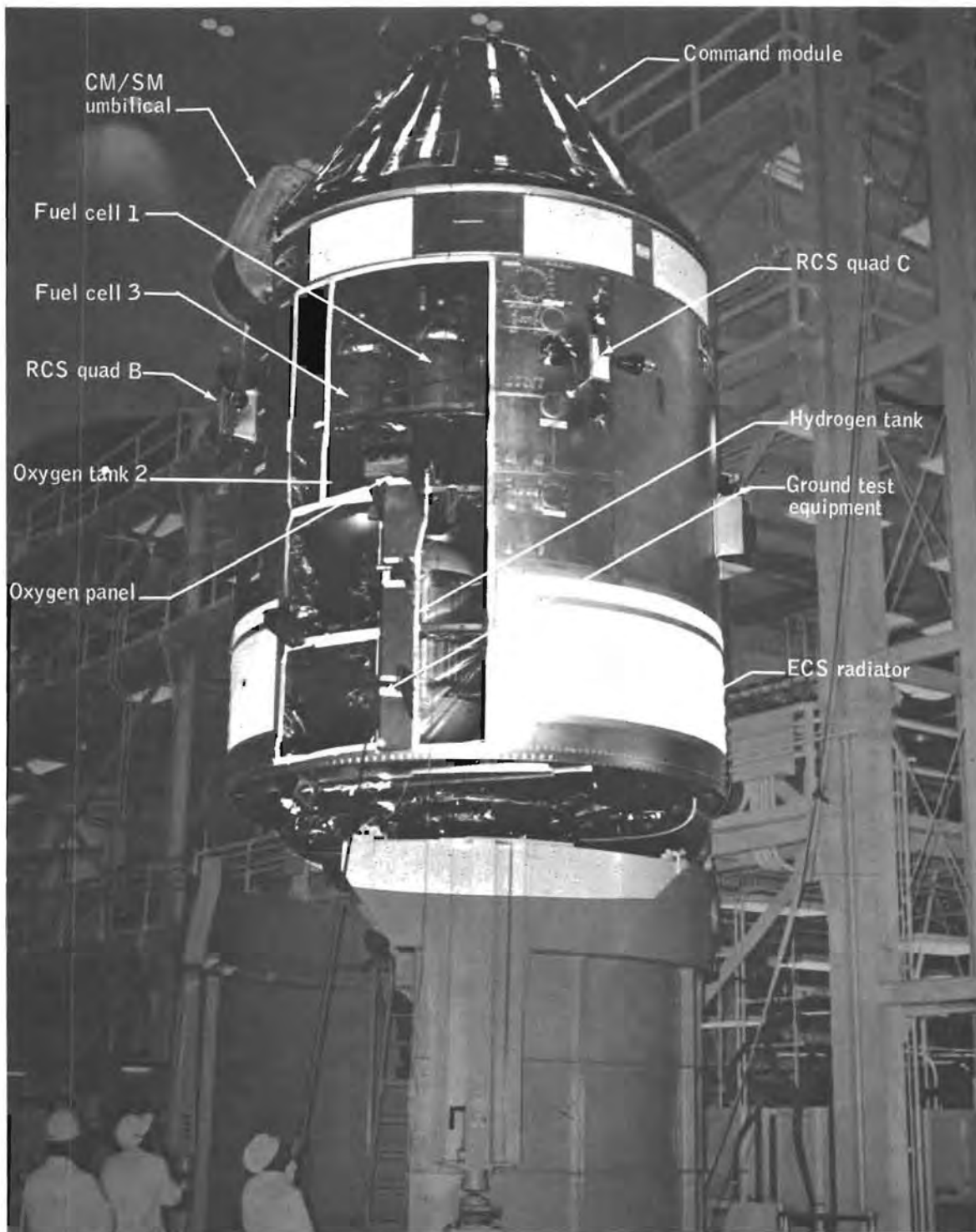

CSM in ground test with bay 4 panel removed.

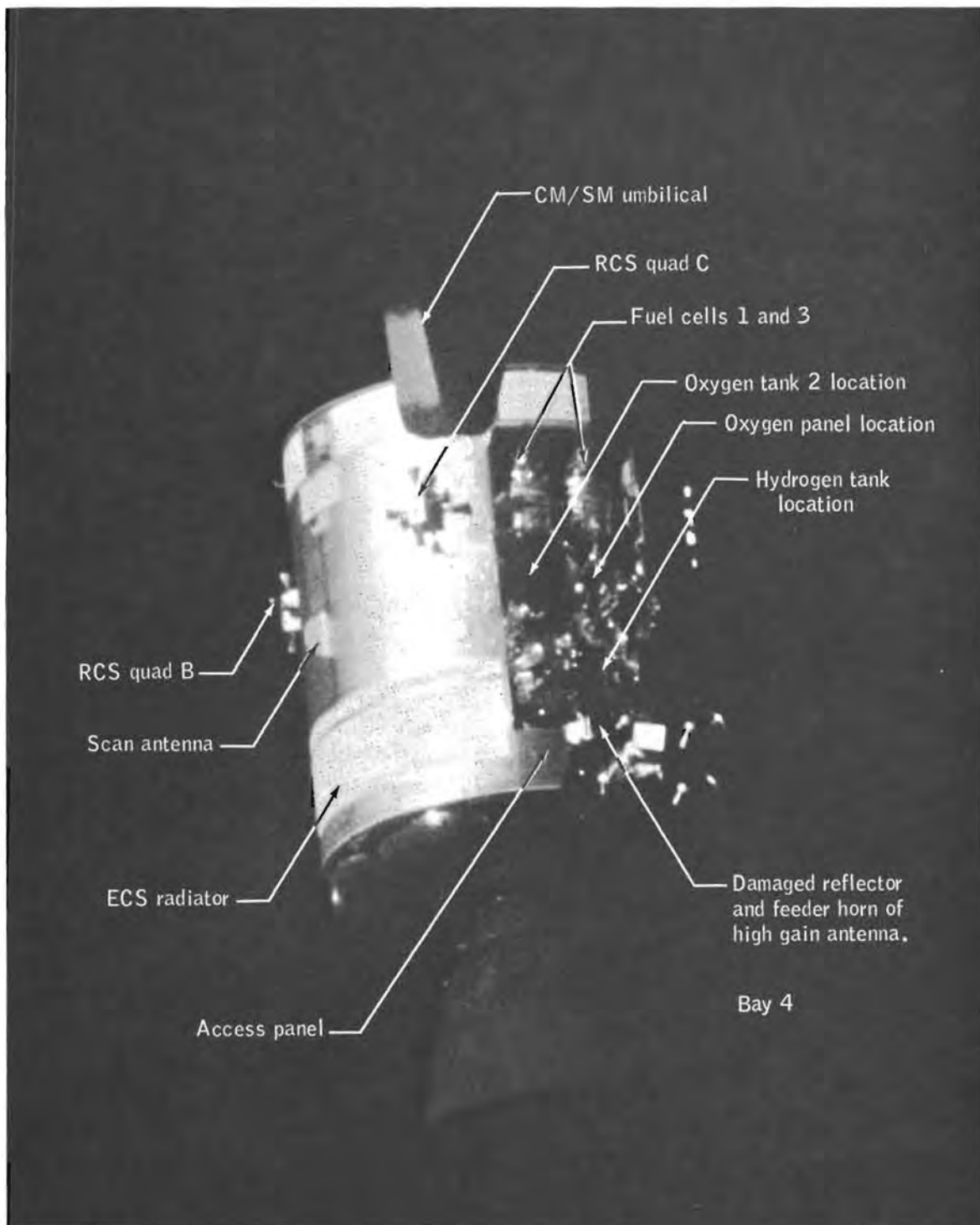

Inflight photograph of service module showing damage to bay 4.

This page left blank intentionally.

TABLE OF CONTENTS

	Page
LETTER OF TRANSMITTAL	
PREFACE	iii
TABLE OF CONTENTS	ix
CHAPTER 1 - AUTHORITIES	
Memorandum, April 17, 1970, from Administrator and Deputy Administrator to Mr. Edgar M. Cortright	1-1
Memorandum, April 21, 1970, from Administrator and Deputy Administrator to Mr. Edgar M. Cortright	1-4
Memorandum, April 20, 1970, from Administrator and Deputy Administrator to Dr. Charles D. Harrington, Chairman, Aerospace Safety Advisory Panel	1-6
Memorandum, April 20, 1970, from Administrator to Mr. Dale D. Myers, Associate Administrator for Manned Space Flight	1-7
NASA Management Instruction 8621.1, Subject: Mission Failure Investigation Policy and Procedures, April 14, 1966	1-8
NASA Management Instruction 1156.14, Subject: Aerospace Safety Advisory Panel, December 7, 1967	1-10
CHAPTER 2 - BOARD HISTORY AND PROCEDURES	
Part 1. Summary of Board History and Procedures	2-1
Part 2. Biography of Board Members, Observers, and Panel Chairmen	2-3
Part 3. Board Organization and General Assignments for Board Panels	2-17
Part 4. Summary of Board Activities	2-27

	Page
CHAPTER 3 - DESCRIPTION OF APOLLO 13 SPACE VEHICLE AND MISSION	
Part 1. Apollo/Saturn V Space Vehicle	3-2
Part 2. Apollo 13 Mission Description	3-26
CHAPTER 4 - REVIEW AND ANALYSIS OF APOLLO 13 ACCIDENT	
Part 1. Introduction	4-1
Part 2. Oxygen Tank No. History	4-2
Part 3. Apollo 13 Flight	4-25
Part 4. Summary Analysis of the Accident	4-36
Part 5. Apollo 13 Recovery	4-44
CHAPTER 5 - FINDINGS, DETERMINATIONS, AND RECOMMENDATIONS	
Part 1. Introduction	5-1
Part 2. Assessment of Accident	5-5
Part 3. Supporting Considerations	5-12
Part 4. Recommendations	5-40
APPENDIX A - BASELINE DATA: APOLLO 13 FLIGHT SYSTEMS AND OPERATIONS	
APPENDIX B - REPORT OF MISSION EVENTS PANEL	
APPENDIX C - REPORT OF MANUFACTURING AND TEST PANEL	
APPENDIX D - REPORT OF DESIGN PANEL	
APPENDIX E - REPORT OF PROJECT MANAGEMENT PANEL	
APPENDIX F - SPECIAL TESTS AND ANALYSES	
APPENDIX G - BOARD ADMINISTRATIVE PRODECURES	
APPENDIX H - BOARD RELEASES AND PRESS STATEMENTS	

CHAPTER 1

AUTHORITIES



NATIONAL AERONAUTICS AND SPACE ADMINISTRATION
WASHINGTON, D.C. 20546

OFFICE OF THE ADMINISTRATOR

April 17, 1970

TO : Mr. Edgar M. Cortright

SUBJECT : Establishment of Apollo 13 Review Board

REFERENCES: (a) NMI 8621.1 - Mission Failure Investigation Policy
and Procedures

(b) NMI 1156.14 - Aerospace Safety Advisory Panel

1. It is NASA policy as stated in Reference (a) "to investigate and document the causes of all major mission failures which occur in the conduct of its space and aeronautical activities and to take appropriate corrective actions as a result of the findings and recommendations."

2. Because of the serious nature of the accident of the Apollo 13 spacecraft which jeopardized human life and caused failure of the Apollo 13 lunar mission, we hereby establish the Apollo 13 Review Board (hereinafter referred to as the Board) and appoint you Chairman. The members of the Board will be qualified senior individuals from NASA and other Government agencies. After consultation with you, we will:

(a) Appoint the members of the Board and make any subsequent changes necessary for the effective operation of the Board; and

(b) Arrange for timely release of information on the operations, findings, and recommendations of the Board to the Congress, and, through the NASA Office of Public Affairs, to the public. The Board will report its findings and recommendations directly to us.

3. The Board will:

(a) Review the circumstances surrounding the accident to the spacecraft which occurred during the flight of Apollo 13 and the subsequent flight and ground actions taken to recover, in order to establish the probable cause or causes of the accident and assess the effectiveness of the recovery actions.

(b) Review all factors relating to the accident and recovery actions the Board determines to be significant and relevant, including studies, findings, recommendations, and other actions that have been or may be undertaken by the program offices, field centers, and contractors involved.

- (c) Direct such further specific investigations as may be necessary.
- (d) Report as soon as possible its findings relating to the cause or causes of the accident and the effectiveness of the flight and ground recovery actions.
- (e) Develop recommendations for corrective or other actions, based upon its findings and determinations or conclusions derived therefrom.
- (f) Document its findings, determinations, and recommendations and submit a final report.

4. As Chairman of the Board you are delegated the following powers:

(a) To establish such procedures for the organization and operation of the Board as you find most effective; such procedures shall be part of the Board's records. The procedures shall be furnished the Aerospace Safety Advisory Panel for its review and comment.

(b) To establish procedures to assure the execution of your responsibilities in your absence.

(c) To designate such representatives, consultants, experts, liaison officers, observers, or other individuals as required to support the activities of the Board. You shall define their duties and responsibilities as part of the Board's records.

(d) To keep us advised periodically concerning the organization, procedures, operations of the Board and its associated activities.

5. By separate action we are requesting the Aerospace Safety Advisory Panel established by Reference (b) to review both the procedures and findings of the Board and submit its independent report to us.

6. By separate action we are directing the Associate Administrator for Manned Space Flight to:

(a) Assure that all elements of the Office of Manned Space Flight cooperate fully with the Board and provide records, data, and technical support as requested.

(b) Undertake through the regular OMSF organization such reviews, studies, and supporting actions as are required to develop recommendations to us on corrective measures to be taken prior to the Apollo 14 mission with respect to hardware, operational procedures, and other aspects of the Apollo program.

7. All elements of NASA will cooperate with the Board and provide full support within their areas of responsibility.



George M. Low
Deputy Administrator



T. O. Paine
Administrator



NATIONAL AERONAUTICS AND SPACE ADMINISTRATION

WASHINGTON, D.C. 20546

OFFICE OF THE ADMINISTRATOR

April 21, 1970

TO : Mr. Edgar M. Cortright

SUBJECT : Membership of Apollo 13 Review Board

Reference: Memorandum to you of April 17, subject: Establishment of
Apollo 13 Review Board

In accordance with paragraph 2(a) of Reference (a), the membership of
the Apollo 13 Review Board is established as follows:

Members:

Mr. Edgar M. Cortright, Chairman (Director, Langley Research Center)
Mr. Robert F. Allnutt (Assistant to the Administrator, NASA Hqs.)
Mr. Neil Armstrong (Astronaut, Manned Spacecraft Center)
Dr. John F. Clark (Director, Goddard Space Flight Center)
Brig. General Walter R. Hedrick, Jr. (Director of Space, DCS/R&D,
Hqs., USAF)
Mr. Vincent L. Johnson (Deputy Associate Administrator-Engineering,
Office of Space Science and Applications)
Mr. Milton Klein (Manager, AEC-NASA Space Nuclear Propulsion Office)
Dr. Hans M. Mark (Director, Ames Research Center)

Counsel:

Mr. George Malley (Chief Counsel, Langley Research Center)

OMSF Technical Support:

Mr. Charles W. Mathews (Deputy Associate Administrator, Office of
Manned Space Flight)

Observers:

Mr. William A. Anders (Executive Secretary, National Aeronautics
and Space Council)

Dr. Charles D. Harrington (Chairman, NASA Aerospace Safety
Advisory Panel)
Mr. I. I. Pinkel (Director, Aerospace Safety Research and
Data Institute, Lewis Research Center)

Congressional Liaison:

Mr. Gerald J. Mossinghoff (Office of Legislative Affairs, NASA Hqs.)

Public Affairs Liaison:

Mr. Brian Duff (Public Affairs Officer, Manned Spacecraft Center)

In accordance with applicable NASA instruction, you are authorized to
appoint such experts and additional consultants as are required for
the effective operations of the Board.

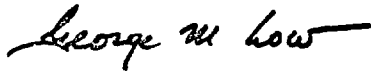

George M. Low
Deputy Administrator



T. O. Paine
Administrator



NATIONAL AERONAUTICS AND SPACE ADMINISTRATION
WASHINGTON, D.C. 20546

April 20, 1970

OFFICE OF THE ADMINISTRATOR

TO : Dr. Charles D. Harrington
Chairman, Aerospace Safety Advisory Panel

SUBJECT : Review of Procedures and Findings of Apollo 13 Review Board

Attachment: (a) Memorandum dated April 17, 1970, to Mr. Edgar M. Cortright, subject: Establishment of Apollo 13 Review Board

References: (a) Section 6, National Aeronautics and Space Administration Authorization Act, 1968

(b) NMI 1156.14 - Aerospace Safety Advisory Panel

1. In accordance with References (a) and (b), the Aerospace Safety Advisory Panel (hereafter referred to as the Panel) is requested to review the procedures and findings of the Apollo 13 Review Board (hereafter referred to as the Board) established by Attachment (a).
2. The procedures established by the Board will be made available to the Panel for review and comment as provided in paragraph 4(a) of Attachment (a).
3. As Chairman of the Panel, you are designated an Observer on the Board. In this capacity, you, or another member of the Panel designated by you, are authorized to be present at those regular meetings of the Board you desire to attend. You are also authorized to receive oral progress reports from the Chairman of the Board or his designee from time to time to enable you to keep the Panel fully informed on the work of the Board.
4. The final report and any interim reports of the Board will be made available promptly to the Panel for its review.
5. The Panel is requested to report to us on the procedures and findings of the Board at such times and in such form as you consider appropriate, but no later than 10 days after the submission to us of the final report of the Board.

A handwritten signature in cursive script that reads "George M. Low".

George M. Low
Deputy Administrator

A handwritten signature in cursive script that reads "T. O. Paine".

T. O. Paine
Administrator

Enclosure

cc: Mr. Edgar M. Cortright, Chairman, Apollo 13 Review Board
M/Mr. Dale Myers



NATIONAL AERONAUTICS AND SPACE ADMINISTRATION
WASHINGTON, D.C. 20546

April 20, 1970

OFFICE OF THE ADMINISTRATOR

TO : Mr. Dale D. Myers
Associate Administrator for Manned Space Flight

SUBJECT : Apollo 13 Review

References: (a) Memorandum dated April 17, 1970, to Mr. Edgar M. Cortright, subject: Establishment of Apollo 13 Review Board

(b) Memorandum dated April 20, 1970, to Dr. Charles D. Harrington, subject: Review of Procedures and Findings of Apollo 13 Review Board

1. As indicated in paragraph 6 of Reference (a), you are directed to:

- (a) Assure that all elements of the Office of Manned Space Flight cooperate fully with the Board in providing records, data, and technical support as requested.
- (b) Undertake through the regular OMSF organization such reviews, studies, and supporting actions as are required to develop timely recommendations to us on corrective measures to be taken prior to the Apollo 14 mission with respect to hardware, operational procedures, flight crews, and other aspects of the Apollo program.

2. The recommendations referred to in paragraph 1(b) above should be submitted to us in such form and at such time as you deem appropriate, but a report should be submitted no later than ten days after the Apollo 13 Review Board submits its final report.

3. The assignments to the Apollo 13 Review Board and to the Aerospace Safety Advisory Panel by References (a) and (b), respectively, in no way relieve you of your continuing full responsibility for the conduct of the Apollo and other OMSF programs.

A handwritten signature in cursive script that reads "George M. Low".

Deputy Administrator

A handwritten signature in cursive script that reads "J. Edgar Hoover".

Administrator

cc: Mr. Edgar M. Cortright, Chairman, Apollo 13 Review Board
Mr. Charles D. Harrington, Chairman, Aerospace Safety Advisory Panel



NMI 8621.1 _____

April 14, 1966

Effective date

Management Instruction

SUBJECT: MISSION FAILURE INVESTIGATION POLICY AND PROCEDURES

1. PURPOSE

This Instruction establishes the policy and procedures for investigating and documenting the causes of all major mission failures which occur in the conduct of NASA space and aeronautical activities.

2. APPLICABILITY

This Instruction is applicable to NASA Headquarters and field installations.

3. DEFINITION

For the purpose of this Instruction, the following term shall apply:

In general, a failure is defined as not achieving a major mission objective.

4. POLICY

- a. It is NASA policy to investigate and document the causes of all major mission failures which occur in the conduct of its space and aeronautical activities and to take appropriate corrective actions as a result of the findings and recommendations.
- b. The Deputy Administrator may conduct independent investigations of major failures in addition to those investigations required of the Officials-in-Charge of Headquarters Program Offices as set forth in paragraph 5a.

5. PROCEDURES

- a. Officials-in-Charge of Headquarters Program Offices are responsible, within their assigned areas, for:
 - (1) Informing promptly the Deputy Administrator of each major failure and apprising him of the nature of the failure, status of investigations, and corrective or other actions which are or will be taken.

April 14, 1966

(2) Determining the causes or probable causes of all failures, taking corrective or other actions, and submitting written reports of such determinations and actions to the Deputy Administrator.

b. When the Deputy Administrator decides to conduct an independent investigation, he will:

(1) Establish a (name of project) Review Board, comprised of appropriate NASA officials;

(2) Define the specific responsibilities of each Board, encompassing such tasks as:

(a) Reviewing the findings, determinations and corrective or other actions which have been developed by contractors, field installations and the Official-in-Charge of cognizant Headquarters Program Office and presenting the Board's conclusions as to their adequacy to the Deputy Administrator.

(b) Reviewing the findings during the course of investigations with cognizant field installation and Headquarters officials.

(c) Recommending such additional steps (for example additional tests) as are considered desirable, to determine the technical and operational causes or probable causes of failure, and to obtain evidence of nontechnical contributing factors.

(d) Developing recommendations for corrective and other actions, based on all information available to the Board.

(e) Documenting findings, determinations and recommendations for corrective or other actions and submitting such documentation to the Deputy Administrator.

c. Procedures for implementing the Board's recommendations shall be determined by the Deputy Administrator.

6. CANCELLATION

NASA Management Manual Instruction 4-1-7 (T.S. 760), March 24, 1964.

R. C. Searle

Deputy Administrator

DISTRIBUTION:
SDL 1



NMI 1156.14

December 7, 1967

Effective date

Management Instruction

SUBJECT: AEROSPACE SAFETY ADVISORY PANEL

1. PURPOSE

This Instruction sets forth the authority for, and the duties, procedures, organization, and support of the Aerospace Safety Advisory Panel.

2. AUTHORITY

The Aerospace Safety Advisory Panel (hereafter called the "Panel") was established under Section 6 of the National Aeronautics and Space Administration Authorization Act, 1968 (PL 90-67, 90th Congress, 81 Stat. 168, 170). Since the Panel was established by statute, its formation and use are not subject to the provisions of Executive Order 11007 or of NMI 1150.2, except to the extent that such provisions are made applicable to the Panel under this Instruction.

3. DUTIES

- a. The duties of the Panel are set forth in Section 6 of the National Aeronautics and Space Administration Authorization Act, 1968, as follows:

"The Panel shall review safety studies and operations plans referred to it and shall make reports thereon, shall advise the Administrator with respect to the hazards of proposed or existing facilities and proposed operations and with respect to the adequacy of proposed or existing safety standards, and shall perform such other duties as the Administrator may request."

- b. Pursuant to carrying out its statutory duties, the Panel will review, evaluate, and advise on all elements of NASA's safety system, including especially the industrial safety, systems safety,

December 7, 1967

and public safety activities, and the management of these activities. These key elements of NASA's safety system are identified and delineated as follows:

- (1) Industrial Safety. This element includes those activities which, on a continuing basis, provide protection for the well being of personnel and prevention of damage to property involved in NASA's business and exposed to potential hazards associated with carrying out this business. Industrial safety relates especially to the operation of facilities in the many programs of research, development, manufacture, test, operation, and maintenance. Industrial safety activities include, but are not limited to, such functions as:
 - (a) Determination of industrial safety criteria.
 - (b) Establishment and implementation of safety standards and procedures for operation and maintenance of facilities, especially test and hazardous environment facilities.
 - (c) Development of safety requirements for the design of new facilities.
 - (d) Establishment and implementation of safety standards and procedures for operation of program support and administrative aircraft.
- (2) Systems Safety. This element includes those activities specifically organized to deal with the potential hazards of complex R&D systems that involve many highly specialized areas of technology. It places particular emphasis on achieving safe operation of these systems over their life cycles, and it covers major systems for aeronautical and space flight activities, manned or unmanned, including associated ground-based research, development, manufacturing, and test activities. Systems safety activities include, but are not limited to, such functions as:
 - (a) Determination of systems safety criteria, including criteria for crew safety.
 - (b) Determination of safety data requirements.
 - (c) Performance of systems safety analyses.

- (d) Establishment and implementation of systems safety plans.
- (3) Public Safety. This element includes those activities which, on a continuing basis, provide protection for the well being of people and prevention of damage to property not involved in NASA's business, but which may nevertheless be exposed to potential hazards associated with carrying out this business. Public safety activities include, but are not limited to, such functions as:
- (a) Determination of public safety criteria.
 - (b) Establishment and control of public safety hazards associated with facility and systems tests and operations.
 - (c) Establishment and implementation, as required, of emergency or catastrophe control plans.
- (4) Safety Management. This element includes both the program and functional organizations of NASA and its contractors involved in the identification of potential hazards and their elimination or control as set forth in the foregoing description of safety activities. It also includes the management systems for planning, implementing, coordinating, and controlling these activities. These management systems include, but are not limited to, the following:
- (a) The authorities, responsibilities, and working relationships of the organizations involved in safety activities, and the assessment of their effectiveness.
 - (b) The procedures for insuring the currency and continuity of safety activities, especially systems safety activities which may extend over long periods of time and where management responsibilities are transferred during the life cycles of the systems.
 - (c) The plans and procedures for accident/incident investigations, including those for the follow-up on corrective actions and the feedback of accident/incident information to other involved or interested organizations.
 - (d) The analysis and dissemination of safety data.

4. PROCEDURES

- a. The Panel will function in an advisory capacity to the Administrator, and, through him, to those organizational elements responsible for management of the NASA safety activities.
- b. The Panel will be provided with all information required to discharge its advisory responsibilities as they pertain to both NASA and its contractors' safety activities. This information will be made available through the mechanism of appropriate reports, and by means of in situ reviews of safety activities at the various NASA and contractor sites, as deemed necessary by the Panel and arranged through the Administrator. The Panel will thus be enabled to examine and evaluate not only the general status of the NASA safety system, but also the key elements of the planned and on-going activities in this system.

5. ORGANIZATIONa. Membership

- (1) The Panel will consist of a maximum of nine members, who will be appointed by the Administrator. Appointments will be for a term of six years, except that, in order to provide continuity of membership, one-third of the members appointed originally to the Panel will be appointed for a term of two years, one-third for a term of four years, and one-third for a term of six years.
- (2) Not more than four members of the Panel shall be employees of NASA, nor shall such NASA members constitute a majority of the composition of the Panel at any given time.
- (3) Compensation and travel allowances for Panel members shall be as specified in Section 6 of the NASA Authorization Act, 1968.

b. Officers

- (1) The Officers of the Panel shall be a Chairman and a Vice Chairman, who shall be selected by the Panel from their membership to serve for one-year terms.
- (2) The Chairman, or Vice Chairman in his absence, shall preside at all meetings of the Panel and shall have the usual powers of a presiding officer.

c. Committees

- (1) The Panel is authorized to establish special committees, as necessary and as approved by the Administrator, to carry out specified tasks within the scope of duties of the Panel.
- (2) All such committee activities will be considered an inseparable extension of Panel activities, and will be in accordance with all applicable procedures and regulations set forth in this Instruction.
- (3) The Chairman of each special committee shall be a member of the Aerospace Safety Advisory Panel. The other committee members may or may not be members of the Panel, as recommended by the Panel and approved by the Administrator.
- (4) Appointment of Panel members to committees as officers or members will be either for one year, for the duration of their term as Panel members, or for the lifetime of the committee, whichever is the shortest. Appointments of non-Panel members to committees will be for a period of one year or for the lifetime of the committee, whichever is shorter.
- (5) Compensation and travel allowances for committee members who are not members of the Panel shall be the same as for members of the Panel itself, except that compensation for such committee members appointed from outside the Federal Government shall be at the rate prescribed by the Administrator for comparable services.

d. Meetings

- (1) Regular meetings of the Panel will be held as often as necessary and at least twice a year. One meeting each year shall be an Annual Meeting. Business conducted at this meeting will include selecting the Chairman and the Vice Chairman of the Panel, recommending new committees and committee members as required or desired, approving the Panel's annual report to the Administrator, and such other business as may be required.
- (2) Special meetings of the Panel may be called by the Chairman, by notice served personally upon or by mail or telegraph to the usual address of each member at least five days prior to the meeting.

- (3) Special meetings shall be called in the same manner by the Chairman, upon the written request of three members of the Panel.
- (4) If practicable, the object of a special meeting should be sent in writing to all members, and if possible a special meeting should be avoided by obtaining the views of members by mail or otherwise, both on the question requiring the meeting and on the question of calling a special meeting.
- (5) All meetings of special committees will be called by their respective chairmen pursuant to and in accordance with performing their specified tasks.
- (6) Minutes of all meetings of the Panel, and of special committees established by the Panel, will be kept. Such minutes shall, at a minimum, contain a record of persons present, a description of matters discussed and conclusions reached, and copies of all reports received, issued, or approved by the Panel or committee. The accuracy of all minutes will be certified to by the Chairman of the Panel (or by the Vice Chairman in his absence) or of the committee.

e. Reports and Records

- (1) The Panel shall submit an annual report to the Administrator.
- (2) The Panel will submit to the Administrator reports on all safety reviews and evaluations with comments and recommendations as deemed appropriate by the Panel.
- (3) All records and files of the Panel, including agendas, minutes of Panel and committee meetings, studies, analyses, reports, or other data compilations or work papers, made available to or prepared by or for the Panel, will be retained by the Panel.

f. Avoidance of Conflicts of Interest

- (1) Nongovernmental members of the Panel, and of special committees established by the Panel, are "Special Government Employees" within the meaning of NHB 1900.2A, which sets forth guidance to NASA Special Government Employees regarding the avoidance of conflicts of interest and the observance of ethical standards of conduct. A

copy of NHB 1900.2A and related NASA instructions on conflicts of interest will be furnished to each Panel or committee member at the time of his appointment as a NASA consultant or expert.

- (2) Nongovernmental members of the Panel or a special committee will submit a "NASA Special Government Employees Confidential Statement of Employment and Financial Interests" (NASA Form 1271) prior to participating in the activities of the Panel or a special committee.

6. SUPPORT

- a. A staff, to be comprised of full-time NASA employees, shall be established to support the Panel. The members of this staff will be fully responsive to direction from the Chairman of the Panel.
- b. The director of this staff will serve as Executive Secretary to the Panel. The Executive Secretary of the Panel, in accordance with the specific instructions from the Chairman of the Panel, shall:
 - (1) Administer the affairs of the Panel and have general supervision of all arrangements for safety reviews and evaluations, and other matters undertaken by the Panel.
 - (2) Insure that a written record is kept of all transactions, and submit the same to the Panel for approval at each subsequent meeting.
 - (3) Insure that the same service is provided for all special committees of the Panel.

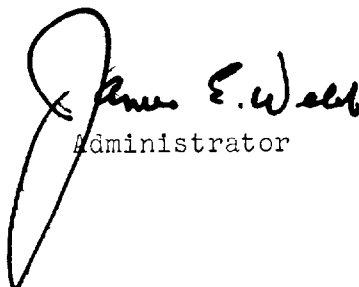
Administrator

CFR Title 14, Chapter 5, Subpart 1209.5.

CHAPTER 2

BOARD HISTORY AND PROCEDURES

PART 1. SUMMARY OF BOARD HISTORY AND PROCEDURES

The Apollo 13 Review Board was established on April 17, 1970, by the NASA Administrator and Deputy Administrator under the authority of NASA Management Instruction 8621.1, dated April 14, 1966. In the letter establishing the Board, Mr. Edgar M. Cortright, Director of Langley Research Center, was appointed as Chairman and the general responsibilities of the Board were set forth. The seven additional members of the Board were named in a letter from the Administrator and the Deputy Administrator to the Chairman, dated April 21, 1970. This letter also designated a Manned Space Flight Technical Support official, a Counselor to the Board, several other supporting officials, and several observers from various organizations. In addition, in a letter dated April 20, 1970, to Dr. Charles D. Harrington, Chairman of the NASA Aerospace Safety Advisory Panel, that Panel was requested to review the Board's procedures and findings.

The Review Board convened at the Manned Spacecraft Center, Houston, Texas, on Tuesday, April 21, 1970. Four Panels of the Board were formed, each under the overview of a member of the Board. Each of the Panels was chaired by a senior official experienced in the area of review assigned to the Panel. In addition, each Panel was manned by a number of specialists, thereby providing a nucleus of expertise for the review activity. During the period of the Board's review activities, the Chairmen of the four Panels were responsible for the conduct of evaluations, analyses, and other studies bearing on their Panel assignments, for preparing preliminary findings and recommendations, and for developing other information for the Board's consideration. To overview these Panel efforts, each member of the Board assumed specific responsibilities related to the overall review.

In addition to the direct participants in the Board activity, a number of observers and consultants also attended various meetings of the Board or its constituent Panels. These individuals assisted the Review Board participants with advice and counsel in their areas of expertise and responsibilities.

While the Board's intensive review activities were underway, the Manned Spacecraft Center Apollo 13 Investigation Team, under James A. McDivitt, Colonel, USAF, was also conducting its own analysis of the accident on Apollo 13. Coordination between the Investigation Team work and the Apollo 13 Review Board activities was effected through the MSF Technical Support official and by maintaining a close and continuing working relationship between the Panel Chairmen and officials of the MSC Investigation Team.

The Board Chairman established a series of administrative procedures to guide the Board's activities. In addition, specific assignments of responsibility were made to all individuals involved in the Board's activities so as to insure an efficient review activity. Overall logistic and administrative support was provided by MSC.

The Board conducted both Executive and General Sessions. During the Executive Sessions, plans were agreed upon for guiding the Board's activities and for establishing priorities for tests, analyses, studies, and other Board efforts. At the General Sessions, status of Panel activities was reviewed by the Board with a view towards coordination and integration of all review activities. In addition, Board members regularly attended daily status meetings of the Manned Spacecraft Center Investigation Team.

In general, the Board relied on Manned Spacecraft Center postmission evaluation activities to provide the factual data upon which evaluation, assessment, and analysis efforts could be based. However, the Board, through a regular procedure, also levied specific data collection, reduction, and analysis requirements on MSC. Test support for the Board was conducted primarily at MSC but also included tests run at other NASA Centers. Members of the Board and its Panels also visited a number of contractor facilities to review manufacturing, assembly, and test procedures applicable to the Apollo 13 mission.

The Chairman of the Board provided the NASA Deputy Administrator with oral progress reports. These reports summarized the status of Review Board activities at the time and outlined the tasks still ahead. All material used in these interim briefings was incorporated into the Board's official files.

As a means of formally transmitting its findings, determinations, and recommendations, the Board chose the format of this Final Report which includes both the Board's judgments as well as the reports of the individual Panels.

A general file of all the data and information collected and examined by the Board has been established at the Langley Research Center, Hampton, Virginia. In addition, the MSC Investigation Team established a file of data at MSC.

PART 2. BIOGRAPHIES OF BOARD MEMBERS, OBSERVERS, AND PANEL CHAIRMEN

CHAIRMAN OF THE APOLLO 13 REVIEW BOARD

EDGAR M. CORTRIGHT
NASA Langley Research Center

Edgar M. Cortright, 46, Director of the NASA Langley Research Center, Hampton, Virginia, is Chairman of the Apollo 13 Review Board.

Mr. Cortright has been an aerospace scientist and administrator for 22 years. He began his career at NASA's Lewis Research Center, Cleveland, Ohio, in 1948 and for the next 10 years specialized in research on high-speed aerodynamics there.

In October 1958, Mr. Cortright was named Chief of Advanced Technology Programs at NASA Headquarters, Washington, D. C., where he directed initial formulation of NASA's Meteorological Satellite Program. In 1960, he became Assistant Director for Lunar and Planetary Programs and directed the planning and implementation of such projects as Mariner, Ranger, and Surveyor.

Mr. Cortright became Deputy Director of the Office of Space Sciences in 1961, and Deputy Associate Administrator for Space Science and Applications in 1963, in which capacities he served as General Manager of NASA's space flight program using automated spacecraft. He joined the Office of Manned Space Flight as Deputy Associate Administrator in 1967 and served in a similar capacity until he was appointed Director of the Langley Research Center in 1968.

He is a Fellow of the American Institute of Aeronautics and Astronautics and of the American Astronautical Society. He has received the Arthur S. Fleming Award, the NASA Medal for Outstanding Leadership, and the NASA Medal for Distinguished Service.

Mr. Cortright is the author of numerous technical reports and articles, and compiled and edited the book, "Exploring Space With a Camera."

He is a native of Hastings, Pennsylvania, and served as a U.S. Navy officer in World War II. He received Bachelor and Master of Science degrees in aeronautical engineering from the Rensselaer Polytechnic Institute.

Mr. and Mrs. Cortright are the parents of two children.

MEMBERS OF THE APOLLO 13 REVIEW BOARD

ROBERT F. ALLNUTT
NASA Headquarters

Robert F. Allnutt, 34, Assistant to the NASA Administrator, Washington, D. C., is a member of the Apollo 13 Review Board.

Mr. Allnutt was named to his present position this year. Prior to that, he had been Assistant Administrator for Legislative Affairs since 1967.

He joined NASA in 1960 as a patent attorney at the Langley Research Center, Hampton, Virginia. In 1961, he was transferred to NASA Headquarters, Washington, D. C.

Mr. Allnutt served as Patent Counsel for Communications Satellite Corporation from January to September 1965, when he returned to NASA Headquarters as Assistant General Counsel for Patent Matters.

He is admitted to the practice of law in the District of Columbia and the state of Virginia and is a member of the American Bar Association and the Federal Bar Association.

Mr. Allnutt was graduated from Virginia Polytechnic Institute with a B.S. degree in industrial engineering. He received Juris Doctor and Master of Laws degrees from George Washington University Law School.

Mr. and Mrs. Allnutt are the parents of two sons. The family lives in Washington, D. C.

NEIL A. ARMSTRONG
NASA Astronaut

Neil A. Armstrong, 39, NASA astronaut, is a member of the Apollo 13 Review Board.

Commander of the Apollo 11 mission and the first man on the Moon, Mr. Armstrong has distinguished himself as an astronaut and as an engineering test pilot.

Prior to joining the astronaut team at the Manned Spacecraft Center, Houston, Texas, in 1962, Mr. Armstrong was an X-15 rocket aircraft project pilot at the NASA Flight Research Center, Edwards, California.

Mr. Armstrong joined NASA at the Lewis Research Center, Cleveland, Ohio, in 1955, and later transferred to the Flight Research Center as an aeronautical research pilot.

His initial space flight was as command pilot of Gemini VIII, launched March 16, 1966. He performed the first successful docking of two vehicles in space. The flight was terminated early due to a malfunctioning thruster, and the crew was cited for exceptional piloting skill in overcoming the problem and accomplishing a safe landing. He has served on backup crews for both Gemini and Apollo.

Mr. Armstrong is a Fellow of the Society of Experimental Test Pilots, Associate Fellow of the American Institute of Aeronautics and Astronautics, and member of the Soaring Society of America. He has received the Institute of Aerospace Sciences Octave Chanute Award, the AIAA Astronautics Award, the NASA Exceptional Service Medal, the John F. Montgomery Award, and the Presidential Medal of Freedom.

He is a native of Wapakoneta, Ohio, and received a B.S. degree in aeronautical engineering from Purdue University and a M.S. degree from the University of Southern California. He was a naval aviator from 1949 to 1952 and flew 78 combat missions during the Korean action.

Mr. and Mrs. Armstrong have two sons.

JOHN F. CLARK
NASA Goddard Space Flight Center

Dr. John F. Clark, 49, Director of the NASA Goddard Space Flight Center, Greenbelt, Maryland, is a member of the Apollo 13 Review Board.

He is an internationally known authority on atmospheric and space sciences, holds four patents in electronic circuits and systems, and has written many scientific papers on atmospheric physics, electronics, and mathematics.

Dr. Clark joined NASA in 1958 and served in the Office of Space Flight Programs at NASA Headquarters until 1961 when he was named Director of Geophysics and Astronomy Programs, Office of Space Sciences. From 1962 until 1965, he was Director of Sciences and Chairman of the Space Science Steering Committee, Office of Space Science and Applications.

In 1965, Dr. Clark was appointed Deputy Associate Administrator for Space Science and Applications (Sciences), and later that year, Acting Director of Goddard. He was named director of the center in 1966.

Dr. Clark began his career in 1942 as an electronics engineer at the Naval Research Laboratory, Washington, D.C. From 1947 to 1948 he was Assistant Professor of Electronic Engineering at Lehigh University, Bethlehem, Pennsylvania. He returned to NRL in 1948; and prior to joining NASA, served as head of the Atmospheric Electricity Branch there.

He is a member of the American Association of Physics Teachers, American Geophysical Union, Scientific Research Society of America, Philosophical Society of Washington, the International Scientific Radio Union, and the Visiting Committee on Physics, Lehigh University. He received the NASA Medals for Exceptional Service, Outstanding Leadership, and Distinguished Service.

Dr. Clark was born in Reading, Pennsylvania. He received a B.S. degree in electrical engineering from Lehigh University, M.S. degree in mathematics from George Washington University, and Ph. D. in physics from the University of Maryland.

Dr. and Mrs. Clark have two children and live in Silver Springs, Maryland.

WALTER R. HEDRICK, JR.
Headquarters, USAF

Brig. Gen. Walter R. Hedrick, Jr., 48, Director of Space, Office of the Deputy Chief of Staff for Research and Development, Headquarters, USAF, Washington, D.C., is a member of the Apollo 13 Review Board.

He has participated in most of the Air Force's major nuclear test projects and has extensive experience as a technical project officer and administrator.

General Hedrick joined the Army Air Corps as an aviation cadet in 1941 and flew in combat with the 86th Fighter Bomber Group during World War II. After the War, he was assigned to the 19th Air Force, the 14th Air Force, and as a project officer under Air Force Secretary Stuart Symington. From 1952 to 1955, he was assigned to the Air Force Office of Atomic Energy.

In 1955, he was assigned to the Technical Operations Division, Air Force Special Weapons Command, Kirtland Air Force Base, New Mexico. In 1957, he was named Commander of the 4951st Support Squadron, Eniwetok; and the following year, he was reassigned to Kirtland AFB as Assistant to the Group Commander and later as Air Commander of the 4925th Test Group.

General Hedrick joined the Special Systems Office, Air Force Ballistics Division, Los Angeles, in 1960. He was named Commander of

the Satellite Control Facility in 1965, and in 1966, he was appointed Deputy Commander, Air Force Systems Command. He received his present assignment in 1967.

General Hedrick is a Command Pilot and has received numerous Air Force awards.

His home town is Fort Worth, Texas, and he attended Texas Technological College, Lubbock, prior to joining the service. He received B.S. and M.S. degrees in physics from the University of Maryland.

General and Mrs. Hedrick are the parents of two sons.

VINCENT L. JOHNSON
NASA Headquarters

Vincent L. Johnson, 51, Deputy Associate Administrator for Space Science and Applications (Engineering), NASA Headquarters, is a member of the Apollo 13 Review Board.

Mr. Johnson was appointed to his present position in 1967. Prior to that time, he had been Director of the Launch Vehicle and Propulsion Programs Division, Office of Space Science and Applications, since 1964. He was responsible for the management and development of the light and medium launch vehicles used for NASA's unmanned earth orbital and deep space programs. His division also directed studies of future unmanned launch vehicle and propulsion system requirements.

Mr. Johnson joined NASA in 1960, coming from the Navy Department where he had been an engineer with the Bureau of Weapons. His first assignments with NASA were as Program Manager for the Scout, Delta, and Centaur launch vehicles.

He was a naval officer during World War II, serving with the Bureau of Ordnance. Prior to that, he was a physicist with the Naval Ordnance Laboratory.

Mr. Johnson was born in Red Wing, Minnesota, and attended the University of Minnesota.

He and Mrs. Johnson live in Bethesda, Maryland. They are the parents of two children.

MILTON KLEIN
NASA Headquarters

Milton Klein, 46, Manager, Space Nuclear Propulsion Office, NASA Headquarters, is a member of the Apollo 13 Review Board.

Mr. Klein has been in his present position since 1967. Prior to that he had been Deputy Manager since 1960. The Space Nuclear Propulsion Office is a joint activity of the Atomic Energy Commission (AEC) and the National Aeronautics and Space Administration. The office conducts the national nuclear rocket program. He is also Director of the Division of Space Nuclear Systems of the AEC, responsible for space nuclear electric power activities.

Mr. Klein became associated with atomic energy work in 1946, when he was employed by the Argonne National Laboratory. In 1950, he joined the AEC's Chicago Operations Office as staff chemical engineer. Later, he was promoted to Assistant Manager for Technical Operations. Generally engaged in reactor development work for stationary power plants, he had a primary role in the power reactor demonstration program.

Mr. Klein was born in St. Louis, Missouri. He served in the U.S. Navy during World War II.

He has a B.S. degree in chemical engineering from Washington University and a Master of Business Administration degree from Harvard University.

Mr. and Mrs. Klein and their three children live in Bethesda, Maryland.

HANS M. MARK
NASA Ames Research Center

Dr. Hans M. Mark, 40, Director of the NASA Ames Research Center, Moffett Field, California, is a member of the Apollo 13 Review Board.

Prior to being appointed Director of the Ames Research Center he was, from 1964 to 1969, Chairman of the Department of Nuclear Engineering at the University of California, Berkeley, California.

An expert in nuclear and atomic physics, he served as Reactor Administrator of the University of California's Berkeley Research Reactor, professor of nuclear engineering and a research physicist at the University's Lawrence Radiation Laboratory, Livermore, California,

and consultant to the U.S. Army and the National Science Foundation. He has written many scientific papers.

Except for 2 years as an Assistant Professor of Physics at the Massachusetts Institute of Technology from 1958 to 1960, Dr. Mark's administrative, academic, and research career has been centered at the University of California (Berkeley).

Dr. Mark received his A.B. degree in physics from the University of California, Berkeley, in 1951, and returned there as a research physicist in 1955, one year after receiving his Ph. D. in physics from M.I.T.

He is a Fellow of the American Physical Society and a member of the American Geophysical Union, the American Society for Engineering Education and the American Nuclear Society.

Dr. Mark was born in Mannheim, Germany, and came to the United States when he was 11 years old. He became a naturalized U.S. citizen in 1945.

Dr. and Mrs. Mark are the parents of two children.

COUNSEL TO THE APOLLO 13 REVIEW BOARD
GEORGE T. MALLEY
NASA Langley Research Center

George T. Malley, 57, Chief Counsel, Langley Research Center, Hampton, Virginia, is the Legal Counsel to the Apollo 13 Review Board. He also served as Counsel to the Apollo 204 Review Board.

Mr. Malley is the Senior Field Counsel of NASA and has been assigned to Langley since 1959. He was with the Office of the General Counsel, Department of the Navy, from 1950 to 1959, where he specialized in admiralty and international law.

He is a retired Navy officer and served on active duty from 1939 to 1946, mainly in the South Pacific. His last assignment was commanding officer of the U.S.S. Fentress.

Mr. Malley has an A.B. degree from the University of Rochester and an LL.B. degree from Cornell University Law School. He is a native of Rochester, New York, and is a member of the New York Bar and the Federal Bar Association.

Mr. and Mrs. Malley and their two children live in Newport News, Virginia.

MANNED SPACE FLIGHT TECHNICAL SUPPORT
CHARLES W. MATHEWS
NASA Headquarters

Charles W. Mathews, 49, Deputy Associate Administrator for Manned Space Flight, NASA Headquarters, Washington, D. C., directs the Office of Manned Space Flight technical support to the Apollo 13 Review Board.

Mr. Mathews has been a research engineer and project manager for NASA and its predecessor, the National Advisory Committee for Aeronautics (NACA), since 1943. In his present assignment, he serves as general manager of manned space flight.

Prior to his appointment to this position in 1968, he had been Director, Apollo Applications Program, NASA Headquarters, since January 1967.

Mr. Mathews was Gemini Program Manager at the Manned Spacecraft Center, Houston, Texas, from 1963 until 1967. Prior to that time, he was Deputy Assistant Director for Engineering and Development and Chief of the Spacecraft Technology Division at MSC.

Mr. Mathews transferred to MSC (then the Space Task Group) when Project Mercury became an official national program in 1958. He served as Chief of the Operation Division. He had been at the Langley Research Center, Hampton, Virginia, since 1943 engaged in aircraft flight research and automatic control of airplanes. He became involved in manned spacecraft studies prior to the first Sputnik flights, and he conducted early studies on reentry. Mr. Mathews was chairman of the group which developed detailed specifications for the Mercury spacecraft.

Mr. Mathews has been awarded the NASA Distinguished Service Medal and the NASA Outstanding Leadership Medal. He has received the NASA Group Achievement Award - Gemini Program Team.

He is a Fellow of the American Astronautical Society and an Associate Fellow of the American Institute of Aeronautics and Astronautics. He is the author of numerous technical articles published by NASA.

Mr. Mathews, a native of Duluth, Minnesota, has a B.S. degree in aeronautical engineering from Rensselaer Polytechnic Institute, Troy, New York.

Mr. and Mrs. Mathews live in Vienna, Virginia. They have two children.

APOLLO 13 REVIEW BOARD OBSERVERS

WILLIAM A. ANDERS
National Aeronautics and Space Council

William A. Anders, 36, Executive Secretary, National Aeronautics and Space Council, Washington, D.C., is an official observer of the Apollo 13 Review Board.

Prior to being appointed to his present position in 1969, Mr. Anders was a NASA astronaut and an Air Force lieutenant colonel. He was lunar module pilot on the Apollo 8 lunar orbital mission, man's first visit to the vicinity of another celestial body.

Mr. Anders joined the NASA astronaut team at the Manned Spacecraft Center, Houston, Texas, in 1963. In addition to his Apollo 8 flight, he served as backup pilot for Gemini 11 and backup command module pilot for Apollo 11, the first lunar landing mission.

Mr. Anders was commissioned a second lieutenant in the Air Force upon graduation from the U.S. Naval Academy. After flight training, he served as a pilot in all-weather interceptor squadrons of the Air Defense Command. Prior to becoming an astronaut, he was a nuclear engineer and instructor pilot at the Air Force Weapons Laboratory, Kirtland Air Force Base, New Mexico.

He is a member of the American Nuclear Society and has been awarded the Air Force Commendation Medal, Air Force Astronaut Wings, the NASA Distinguished Service Medal, and the New York State Medal for Valor.

Mr. Anders was born in Hong Kong. He received a B.S. degree from the U.S. Naval Academy and an M.S. degree in nuclear engineering from the Air Force Institute of Technology.

Mr. and Mrs. Anders are the parents of five children.

CHARLES D. HARRINGTON
Douglas United Nuclear, Inc.

Dr Charles D Harrington, 59, President and General Manager, Douglas United Nuclear, Inc., Richland, Washington, is an official observer of the Apollo 13 Review Board.

Dr. Harrington, who has been associated with all phases of the chemical and nuclear industrial fields since 1941, is Chairman of the Aerospace Safety Advisory Panel, a statutory body created by Congress.

From 1941 to 1961, he was employed by the Mallinckrodt Chemical Works, St. Louis, Missouri. Dr. Harrington started with the company as a research chemist and in 1960, after a procession of research and management positions, was appointed Vice President, Mallinckrodt Nuclear Corporation and Vice President, Mallinckrodt Chemical Works.

In 1961, when the fuel material processing plant of Mallinckrodt became the Chemicals Division of United Nuclear Corporation, Dr. Harrington was named Vice President of that division.

He became Senior Vice President, United Nuclear Corporation, Centreville, Maryland, in 1963.

In 1965, Dr. Harrington was appointed President and General Manager, Douglas United Nuclear, Inc. The company manages production reactors and fuels fabrication facilities at Hanford, Washington, for the Atomic Energy Commission.

He is the co-author of a book, "Uranium Production Technology," and has written numerous technical papers. He has received the Mid-West Award of the American Chemical Society for contributions to technology in the nuclear energy field.

He is director of several corporations, including United Nuclear, as well as professional councils and societies.

Dr. Harrington has M.S., M.A., and Ph. D. degrees in chemistry from Harvard University.

I. IRVING PINKEL
NASA Lewis Research Center

I. Irving Pinkel, 57, Director, Aerospace Safety Research and Data Institute at the NASA Lewis Research Center, Cleveland, Ohio, is an official observer of the Apollo 13 Review Board.

Until recently, he directed research at Lewis Research Center on rocket propellant and electric power generation systems for space vehicles, compressors and turbines for advanced aircraft engines, and lubrication systems for rotating machines for these systems.

Mr. Pinkel entered Government scientific service in 1935 as a physicist with the U.S. Bureau of Mines, Pittsburgh, Pennsylvania. In 1940, he joined the staff of the Langley Research Center, Hampton, Virginia, as a physicist. When the Lewis Research Center was built in 1942, he transferred there.

He has been elected to Phi Beta Kappa, Sigma Xi, honorary scientific society, and Pi Mu Epsilon, honorary mathematics fraternity. He is an Ohio Professional Engineer, served on the former NACA subcommittees on Meteorological Problems, Icing Problems, Aircraft Fire Prevention and Flight Safety, and is a member of the NASA Research and Technology Advisory Subcommittee on Aircraft Operating Problems. He has been a Special Lecturer, Case Institute of Technology Graduate School.

Mr. Pinkel has received the Flight Safety Foundation Award for contributions to the safe utilization of aircraft, the Laura Taber Barbour Award for development of a system for suppressing aircraft crash fires, the NACA Distinguished Service Medal, and the NASA Sustained Superior Performance Award.

He was born in Gloversville, New York, and was graduated from the University of Pennsylvania.

Mr. and Mrs. Pinkel live in Fairview Park, Ohio. They are the parents of two sons.

JAMES E. WILSON, JR.
Committee on Science and Astronautics
United States House of Representatives

James E. Wilson, Jr., 39, Technical Consultant, United States House of Representatives Committee on Science and Astronautics, is an official observer of the Apollo 13 Review Board.

Mr. Wilson has been technical consultant to the Committee since 1963. From 1961 to 1963, he was Director of Research and Development, U.S. Naval Propellant Plant, Indian Head, Maryland. Mr. Wilson managed the Polaris Program at Indian Head from 1956 to 1961.

From 1954 to 1956, Mr. Wilson served as an officer in the U.S. Army Signal Corps. He was a development engineer with E. I. DuPont, Wilmington, Delaware, from 1953 to 1954.

Mr. Wilson is a member of Phi Sigma Alpha, a National Honor Society; American Institute of Chemical Engineers; American Chemical Society; and American Ordnance Association.

Mr. Wilson is co-author of several publications of the House Committee on Science and Astronautics.

He received a B.S. degree in chemical engineering from the University of Maine and a Master of Engineering Administration degree from George Washington University.

Mr. and Mrs. Wilson live in LaPlata, Maryland. They have two children.

APOLLO 13 REVIEW BOARD PANEL CHAIRMEN

SEYMOUR C. HIMMEL
NASA Lewis Research Center

Dr. Seymour C. Himmel, Assistant Director for Rockets and Vehicles, Lewis Research Center, Cleveland, Ohio, heads the Design Panel of the Apollo 13 Review Board.

Dr. Himmel joined Lewis in 1948 as an aeronautical research scientist. He has occupied supervisory positions since 1953.

He has been awarded the NASA Exceptional Service Medal and the NASA Group Achievement Award as manager of the Agena Project Group. Dr. Himmel has served on a number of advisory committees. He is an Associate Fellow of the American Institute of Aeronautics and Astronautics, and a member of Tau Beta Pi and Pi Tau Sigma. He is the author of more than 25 technical papers.

Dr. Himmel has a Bachelor of Mechanical Engineering degree from the College of the City of New York and M.S. and Ph. D. degrees from Case Institute of Technology.

Dr. and Mrs. Himmel live in Lakewood, Ohio.

EDWIN C. KILGORE
NASA Langley Research Center

Edwin C. Kilgore, 47, Deputy Chief, Engineering and Technical Services, Langley Research Center, Hampton, Virginia, heads the Project Management Panel of the Apollo 13 Review Board.

Mr. Kilgore joined the Langley science staff in 1944 and served in a variety of technical and management positions until promotion to his present position in 1968.

He has received the Honorary Group Achievement Award for his role in achieving a record of 97 consecutive successes for solid propellant rocket motors and the NASA-Lunar Orbiter Project Group Achievement Award for outstanding performance. He is a member of Pi Tau Sigma, honorary mechanical engineering society.

Mr. Kilgore was born in Coeburn, Virginia. He was graduated from Virginia Polytechnic Institute with a B.S. degree in mechanical engineering.

Mr. and Mrs. Kilgore and their two daughters live in Hampton.

HARRIS M. SCHURMEIER

California Institute of Technology Jet Propulsion Laboratory

Harris M. Schurmeier, 45, Deputy Assistant Laboratory Director for Flight Projects, California Institute of Technology Jet Propulsion Laboratory, Pasadena, California, heads the Manufacturing and Test Panel of the Apollo 13 Review Board.

Mr. Schurmeier was appointed to his current position in 1969. Prior to that he was Mariner Mars 1969 Project Manager, Voyager Capsule System Manager and Deputy Manager of the Voyager Project, and Ranger Project Manager at JPL.

He has received the NASA Medals for Exceptional Scientific Achievement and Exceptional Service. In addition, he has received the Astronautics Engineer Award, and the NASA Public Service Award.

He was born in St. Paul, Minnesota. He has received a B.S. degree in mechanical engineering, M.S. degree in aeronautical engineering, and a professional degree in aeronautical engineering from the California Institute of Technology.

Mr. Schurmeier was a naval officer in World War II. He and his wife and four children live in Altadena, California.

FRANCIS B. SMITH
NASA Headquarters

Francis B. Smith, 47, Assistant Administrator for University Affairs, NASA Headquarters, is leader of the Mission Events Panel of the Apollo 13 Review Board.

Mr. Smith has been in his present position since 1967. Prior to that he had been Assistant Director, Langley Research Center, Hampton, Virginia, since 1964. He joined the Langley science staff in 1947. He is an expert in several fields, including radio telemetry, radar, electronic tracking systems, and missile and range instrumentation.

Mr. Smith was born in Piedmont, South Carolina, and received a B.S. degree in electrical engineering from the University of South Carolina, where he was elected to Phi Beta Kappa. He remained at the University as an instructor from 1943 to 1944 and then served in the U.S. Navy until 1946.

Mr. and Mrs. Smith and their three children live in Reston, Virginia.

PART 3. BOARD ORGANIZATION AND GENERAL ASSIGNMENTS FOR BOARD PANELS

BOARD ORGANIZATION

After reviewing the scope of the Board's charter, the Chairman and Board Members agreed upon the Panel and Support Office structure depicted on the following organization chart. Each Panel was assigned specific responsibilities for reviewing major elements of the overall Board task, with particular emphasis upon establishing a sound and independent technical data base upon which findings, determinations, and recommendations by the Board could be based. The Panels were staffed with individual NASA specialists and established working arrangements with the Manned Space Flight line organization personnel working in analogous areas.

The Board's support offices were structured to provide necessary staff, logistics, and administrative support without duplication of available MSC assistance.

In addition to this structure, the Board and Panels also utilized the special assistance of expert consultants.

Panel assignments, complete Panel membership, and the official Board organization approved by the Chairman are included in this part of the Board report.

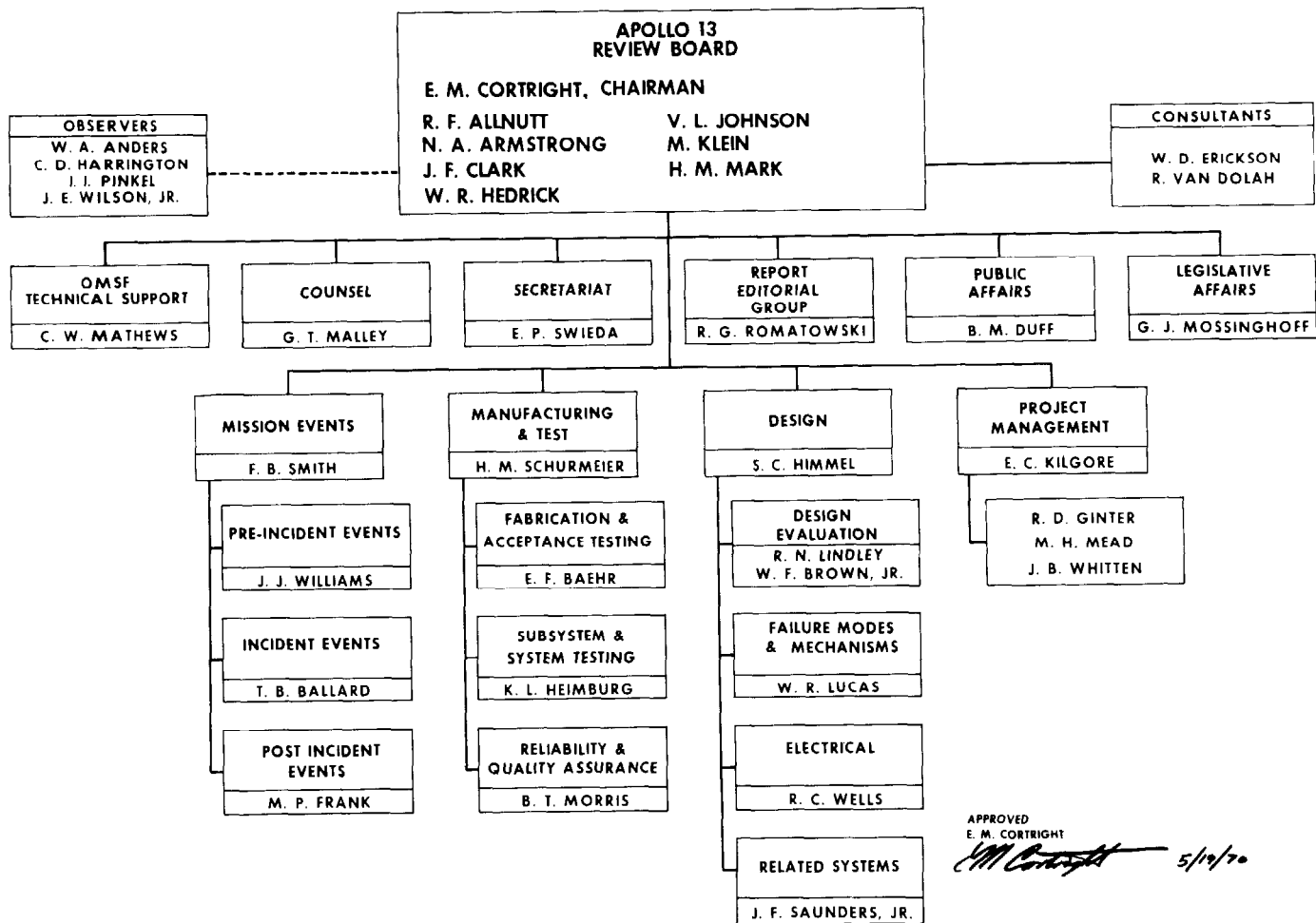

2-18

APOLLO 13 REVIEW BOARD ORGANIZATION

GENERAL ASSIGNMENTS FOR BOARD PANELS
(AS DOCUMENTED IN THE BOARD'S ADMINISTRATIVE PROCEDURES)

Panel 1 - Mission Events Panel

It shall be the task of the Mission Events Panel to provide a detailed and accurate chronology of all pertinent events and actions leading to, during, and subsequent to the Apollo 13 incident. This information, in narrative and graphical time history form, will provide the Apollo 13 Review Board an official events record on which their analysis and conclusions may be based. This record will be published in a form suitable for inclusion in the Review Board's official report.

The Panel will report all significant events derived from telemetry records, air-to-ground communications transcripts, crew and control center observations, and appropriate documents such as the flight plan, mission technique description, Apollo Operation Handbook, and crew checklists. Correlation between various events and other observations related to the failure will be noted. Where telemetry data are referenced, the Panel will comment as appropriate on its significance, reliability, accuracy, and on spacecraft conditions which might have generated the data.

The chronology will consist of three major sections: Preincident Events, Incident Events, and Postincident Events. The decision-making process leading to the safe recovery, referencing the relevant contingency plans and available alternates, will be included.

Preincident Events. - This section will chronicle the progress of the flight from the countdown to the time of the incident. All action and data relevant to the subsequent incident will be included.

Incident Events. - This section will cover that period of time beginning at 55 hours and 52 minutes after lift-off and continuing so long as abnormal system behavior is relevant to the failure.

Postincident Events. - This section will document the events and activities subsequent to the incident and continuing to mission termination (Splash). Emphasis will be placed on the rationale used on mission completion strategy.

Panel 1 Membership

Mr. F. B. Smith, Panel Chairman
Assistant Administrator for University Affairs
NASA Headquarters
Washington, D. C.

Dr. Tom B. Ballard
Aerospace Technologist
Flight Instrument Division
Langley Research Center
Hampton, Virginia

Mr. M. P. Frank
Flight Director
Flight Control Division
Manned Spacecraft Center
Houston, Texas

Mr. John J. Williams
Director, Spacecraft Operations
Kennedy Space Center
Florida

Mr. Neil Armstrong, Board Member and Panel Monitor
Astronaut
Manned Spacecraft Center
Houston, Texas

Panel 2 - Manufacturing and Test Panel

The Manufacturing and Test Panel shall review the manufacturing and testing, including the associated reliability and quality assurance activities, of the flight hardware components involved in the flight failure as determined from the review of the flight data and the analysis of the design. The purpose of this review is to ascertain the adequacy of the manufacturing procedures, including any modifications, and the pre-flight test and checkout program, and any possible correlation of these activities with the inflight events.

The Panel shall consist of three activities:

Fabrication and Acceptance Testing.- This will consist of reviewing the fabrication, assembly, and acceptance testing steps actually used during the manufacturing of the specific flight hardware elements involved. Fabrication, assembly, and acceptance testing procedures and records will be reviewed, as well as observation of actual operations when appropriate.

Subsystem and System Testing.- This will consist of reviewing all the flight qualification testing from the completion of the component-level acceptance testing up through the countdown to lift-off for the specific hardware involved. Test procedures and results will be reviewed

as well as observing specific tests where appropriate. Results of tests on other serial number units will also be reviewed when appropriate.

Reliability and Quality Assurance.- This will be an overview of both the manufacturing and testing, covering such things as parts and material qualification and control, assembly and testing procedures, and inspection and problem/failure reporting and closeout.

Panel 2 Membership

Mr. Harris M. Schurmeier, Panel Chairman
Deputy Assistant Laboratory Director for Flight Projects
Jet Propulsion Laboratory
Pasadena, California

Mr. Edward F. Baehr
Assistant Chief, Launch Vehicles Division
Deputy Manager, Titan Project
Lewis Research Center
Cleveland, Ohio

Mr. Karl L. Heimborg
Director, Astronautics Laboratory
Marshall Space Flight Center
Huntsville, Alabama

Mr. Brooks T. Morris
Manager, Quality Assurance and Reliability Office
Jet Propulsion Laboratory
Pasadena, California

Dr. John F. Clark, Board Member and Panel Monitor
Director
Goddard Space Flight Center
Greenbelt, Maryland

Panel 3 - Design Panel

The Design Panel shall examine the design of the oxygen and associated systems to the extent necessary to support the theory of failure. After such review the Panel shall indicate a course of corrective action which shall include requirements for further investigations and/or re-design. In addition, the Panel shall establish requirements for review of other Apollo spacecraft systems of similar design.

The Panel shall consist of four subdivisions:

Design Evaluation.- This activity shall review the requirements and specifications governing the design of the systems, subsystems and components, their derivation, changes thereto and the reasons therefor; and the design of the system in response to the requirements, including such elements as design approach, material selection, stress analysis, development and qualification test programs, and results. This activity shall also review and evaluate proposed design modifications, including changes in operating procedures required by such modifications.

Failure Modes and Mechanisms.- This activity shall review the design of the systems to ascertain the possible sources of failure and the manner in which failures may occur. In this process, they shall attempt to correlate such modes with the evidence from flight and ground test data. This shall include considerations such as: energy sources, materials compatibility, nature of pressure vessel failure, effects of environment and service, the service history of any suspect systems and components, and any degradation that may have occurred.

Electrical.- This activity shall review the design of all electrical components associated with the theory of failure to ascertain their adequacy. This activity shall also review and evaluate proposed design modifications, including changes in operating procedures required by such modifications.

Related Systems.- This activity shall review the design of all systems similar to that involved in the Apollo 13 incident with the view to establishing any commonality of design that may indicate a need for redesign. They shall also consider the possibility of design modifications to permit damage containment in the event of a failure.

Panel 3 Membership

Dr. Seymour C. Himmel, Panel Chairman
Assistant Director for Rockets and Vehicles
Lewis Research Center
Cleveland, Ohio

Mr. William F. Brown, Jr.
Chief, Strength of Materials Branch
Materials and Structures Division
Administration Directorate
Lewis Research Center
Cleveland, Ohio

Mr. R. N. Lindley
Special Assistant to the Associate Administrator for Manned Space Flight
NASA Headquarters
Washington, D. C.

Dr. William R. Lucas
Director, Program Development
Marshall Space Flight Center
Huntsville, Alabama

Mr. J. F. Saunders, Jr.
Project Officer for Command and Service Module
Office of Manned Space Flight
NASA Headquarters
Washington, D. C.

Mr. Robert C. Wells
Head, Electric Flight Systems Section
Vehicles Branch
Flight Vehicles and Systems Division
Office of Engineering and Technical Services
Langley Research Center
Hampton, Virginia

Mr. Vincent L. Johnson, Board Member and Panel Monitor
Deputy Associate Administrator for Engineering
Office of Space Science and Applications
NASA Headquarters
Washington, D. C.

Panel 4 - Project Management Panel

The Project Management Panel will undertake the following tasks:

1. Review and assess the effectiveness of the management structure employed in Apollo 13 in all areas pertinent to the Apollo 13 incident. This review will encompass the organization, the responsibilities of organizational elements, and the adequacy of the staffing.
2. Review and assess the effectiveness of the management systems employed on Apollo 13 in all areas pertinent to the Apollo 13 incident. This task will include the management systems employed to control the appropriate design, manufacturing, and test operations; the processes used to assure adequate communications between organizational elements; the processes used to control hardware and functional interfaces; the safety processes involved; and protective security.

3. Review the project management lessons learned from the Apollo 13 mission from the standpoint of their applicability to subsequent Apollo missions.

Tasks 1 and 2, above, should encompass both the general review of the processes used in Apollo 13 and specific applicability to the possible cause or causes of the mission incident as identified by the Board.

Panel 4 Membership

E. C. Kilgore, Panel Chairman
Deputy Chief, Office of Engineering and Technical Services
Langley Research Center
Hampton, Virginia

R. D. Ginter
Director of Special Programs Office
Office of Advanced Research and Technology
NASA Headquarters
Washington, D.C.

Merrill H. Mead
Chief of Programs and Resources Office
Ames Research Center
Moffett Field, California

James B. Whitten
Assistant Chief, Aeronautical and Space Mechanics Division
Langley Research Center
Hampton, Virginia

Milton Klein, Board Member and Panel Monitor
Manager, AEC-NASA Space Nuclear Propulsion Office
Washington, D.C.

Board Observers

William A. Anders
Executive Secretary
National Aeronautics and Space Council
Washington, D.C.

Dr. Charles D. Harrington
Chairman
NASA Aerospace Safety Advisory Panel
Washington, D.C.

I. Irving Pinkel
Director
Aerospace Safety Research and Data Institute
Lewis Research Center
Cleveland, Ohio

Mr. James E. Wilson
Technical Consultant to the Committee on Science and Astronautics
United States House of Representatives
Washington, D.C.

Apollo 13 Review Board Support Staff

Brian M. Duff
Public Affairs Officer
Manned Spacecraft Center
Houston, Texas

Gerald J. Mossinghoff
Director of Congressional Liaison
NASA Headquarters
Washington, D.C.

Edward F. Parry
Counsel to Office of Manned Space Flight
NASA Headquarters
Washington, D.C.

Raymond G. Romatowski
Deputy Assistant Director for Administration
Langley Research Center
Hampton, Virginia

Ernest P. Swieda
Deputy Chief, Skylab Program Control Office
Kennedy Space Center, Florida

Consultants to the Board

Dr. Wayne D. Erickson, Head
Aerothermochemistry Branch
Langley Research Center
Hampton, Virginia

Dr. Robert Van Dolah
Acting Research Director
Safety Research Center
Bureau of Mines
Pittsburgh, Pennsylvania

MSC Support to the Board

These persons were detailed by MSC to support the Apollo 13 Review Board during its review activity at MSC. They are identified by MSC position title.

Roy C. Aldridge
Assistant to the Director of Administration

Mary Chandler
Secretary

Jamie Moon
Technical Editor

Rex Cline
Technical Writer/Editor

Dorothy Newberry
Administrative Assistant

Evon Collins
Program Analyst

Lettie Reed
Editorial Assistant

Leroy Cotton
Equipment Specialist

Charlene Rogozinski
Secretary

Maureen Cruz
Travel Clerk

Joanne Sanchez
Secretary

Janet Harris
Clerk Stenographer

Billie Schmidt
Employee Development Specialist

Marjorie Harrison
Secretary

Frances Smith
Secretary

Phyllis Hayes
Secretary

George Sowers
Management Presentations Officer

William N. Henderson
Management Analyst

Elaine Stemerick
Secretary

Sharon Laws
Secretary

Mary Thompson
Administrative Assistant

Carolyn Lisenbee
Secretary

Alvin C. Zuehlke
Electrical Engineer

Judy Miller
Secretary

PART 4. SUMMARY OF BOARD ACTIVITIES

APRIL 19, 1970

Chairman E. M. Cortright met with Langley officials to begin planning the Apollo 13 Review Board approach. Tentative list of Panel Members and other specialists were developed for consideration.

APRIL 20, 1970

Chairman Cortright met with the NASA Administrator, Deputy Administrator, and key NASA officials in Washington, D.C., to discuss Board membership.

The Chairman met with NASA Office of Manned Space Flight top officials while enroute to MSC on NASA aircraft and discussed program organization plans for review of the accident, and coordination with Apollo 13 Review Board activity.

APRIL 21, 1970

Chairman Cortright met with MSC officials to discuss Apollo 13 Review Board support.

A formal MSC debriefing of the Apollo 13 crew was conducted for MSC officials and Apollo 13 Review Board personnel already at MSC.

Detailed discussions between early arrivals on the Review Board and the MSC Investigation Team were held to provide quick-look data on the Apollo 13 accident and to develop detailed procedures for MSC support of the Apollo 13 Board.

Chairman Cortright met with members of the Press to report on early activity of the Board and to inform them of plans for keeping the Press current on Board activities.

The first meeting of the Board was held at 8 p.m. to discuss Board composition, structure, assignments, and scope of review. Preliminary plans were developed for appointing various specialists to assist the Board in its analysis and evaluation.

APRIL 22, 1970

The Board met with Colonel McDivitt's MSC Investigation Team to review the progress made by MSC in identifying causes of the accident and in developing an understanding of sequences and relationships between known inflight events. In addition, MSC officials briefed the Board on MSC Investigation Team structure and assignments.

The Board met with Panel 1 of the MSC Investigation Team for detailed discussion of inflight events and consideration of early conclusions on implications of preliminary data analysis.

The Board held its second meeting to discuss MSC investigative efforts and additional appointments of Panel specialists.

Board members attended Panel 1 evening roundup of day's evaluation activities, which included detailed discussions of specific studies, data reductions, and support test activities already underway.

APRIL 23, 1970

The Apollo 13 Review Board established itself in proximity to the MSC Investigation Team in Building 45, and arranged for all administrative and logistics support to the Board.

A daily schedule of meetings, reviews, briefings, and discussions was established, including preliminary plans for contractor meetings, special support tests, and accumulation of accident-related information.

Initial task assignments and responsibilities were made to Board Panels as guidance for detailed review work. Individual Board members were assigned Panel overview responsibilities or other special tasks.

Administrative procedures were developed for Board activity, particularly to provide efficient interface with MSC personnel.

Board and Panel Members again met with MSC officials to further review the sequence of events in the Apollo 13 mission and to examine early hypotheses concerning causes of these events.

The Board convened for an evening meeting to discuss the progress to date and to coordinate Panel activities for the next few days. Discussion centered upon immediate requirements for data collection and analysis.

Chairman Cortright appointed additional NASA specialists in order to bring Panels up to strength.

APRIL 24, 1970

Board Members, Panel Chairmen, and MSC officials reviewed additional data analysis made by MSC and contractor personnel with particular emphasis upon the service module (SM) cryogenic system.

The Board convened and reviewed the progress to date. Tentative approvals were given for Board trips to North American Rockwell (NR), Downey, California, Beech Aircraft, Boulder, Colorado, and other locations.

Chairman Cortright briefed the Press on progress to date.

Panel Chairmen and Members continued their detailed analysis of failure modes, test histories, mission events, and other data bearing upon the accident.

Board Members and Panel Chairmen met with Mr. Norman Ryker of NR on NR's activities involving design, qualification, and tests of SM cryogenic oxygen tanks.

APRIL 25, 1970

The Board met to discuss details of onsite inspections of command service module (CSM) flight hardware at principal contractor installations.

Panels examined in detail probable failure modes based on data analyzed at that time.

Specific plans were discussed by the Board relating to evaluation of oxygen tank assembly and checkout operations, including review of component histories.

The MSC Investigation Team members briefed Board personnel on Kennedy Space Center checkout operations of the service module cryogenic and electric power systems, including a detailed briefing covering oxygen tank detanking operations.

APRIL 26, 1970

Board and Panel Members traveled to North American Rockwell, Downey, for detailed briefings by NR engineers and management. NR reviewed its

progress in an intensive analysis of the Apollo 13 malfunction, including a review of approved special tests. Oxygen tank, fuel cell components, assemblies, and other hardware were also inspected.

APRIL 27, 1970

An Executive Session of the Board met to discuss progress of specific analyses required to verify tentative conclusions on oxygen tank failure and service module EPS failure.

Additional Board specialists arrived at MSC and received detailed briefings by MSC and Board personnel on selected aspects of the Apollo 13 data.

Panel Members received and assessed a preliminary MSC evaluation of the Apollo 13 accident, including tentative conclusions on the most probable failure modes.

Procedures were established to provide information flow on the status of review to Board observers.

The Board reviewed work plans for the coming week with each Panel and established review priorities and special task assignments.

APRIL 28, 1970

Chairman Cortright outlined a plan for the Board's preliminary report scheduled for presentation to the Deputy Administrator during his visit to MSC on May 1. Each Panel Chairman was to summarize the status of his Panel's activities for Dr. George Low on Friday, April 29, 1970.

Board Member Neil Armstrong completed arrangements to provide each Board Member and Panel Chairman an opportunity for detailed simulation of the Apollo 13 inflight accident using MSC's CSM simulation equipment.

Board and Panel Members reviewed enhanced photographs of the Apollo 13 service module at the MSC Photographic Laboratory.

Dr. von Elbe of Atlantic Research Company briefed Board and Panel Members on cryogenics and combustion phenomena.

A representative of the Manufacturing and Test Panel performed an onsite inspection at Beech Aircraft, Boulder.

Manufacture and Test Panel personnel reviewed detanking procedures followed at KSC during the Apollo 13 countdown demonstration test (CDDT).

Board and Panel personnel reviewed progress to date at a general Board meeting involving all Review Board personnel.

APRIL 29, 1970

Dr. Charles Harrington, Board Observer and Chairman of the Aerospace Safety Advisory Panel, arrived for a 2-day detailed review of Board procedures and progress in the accident review.

The Board reviewed North American Rockwell preliminary recommendations involving oxygen tank redesign.

The Board continued to review and examine oxygen tank ignition sources and combustion propagation processes with specialists from MSC, other NASA Centers, and contractor personnel.

The Mission Events Panel continued to examine and record details of all significant mission events as a basis for other Panel evaluations and study.

Chairman Cortright convened two Board meetings to review Panel progress to date and to discuss work plans for the next several days.

The Project Management Panel visited North American Rockwell at Downey to review detailed procedures for acceptance tests, subcontractor inspections, project documentation, and other management interface areas.

APRIL 30, 1970

The Safety Advisory Panel continued discussions with Board Chairman and MSC officials on progress of total Apollo 13 review efforts.

Panel Members reviewed instrumentation used in Apollo 13 spacecraft in order to establish the validity of telemetry data being used in Board analysis.

Chairman Cortright convened two Board meetings to review progress of the work and to discuss preliminary findings of the Board.

Project Management personnel visited Beech Aircraft Corporation to review procedures used for assembly of cryogenic oxygen tanks and to discuss communication and information systems within the Apollo Program.

Panels continued to review detailed data in their respective areas.

MAY 1, 1970

Board and Panel personnel participated in a joint MSC/Apollo 13 Review Board status presentation to the NASA Deputy Administrator. The meeting covered all significant Apollo 13 findings and early conclusions on the cause of the accident and appropriate remedial actions.

The MSC staff briefed Board Members on initial evaluations of proposed design changes in oxygen tank system.

Panel Members continued to assess data accumulated from the Apollo 13 mission with particular emphasis upon the design and performance of electric power systems used in the service module.

Board Members and Panel Chairmen reviewed specific test matrix being proposed by Apollo 13 Review Board specialists covering most significant unknowns involved in understanding failure mechanisms.

MAY 2, 1970

Board Members met in General Session to discuss preparation of a complete "failure tree" as an additional guide in conducting a complete review and investigation. Specific aspects of this approach were reviewed.

The Project Management Panel reviewed oxygen tank reliability history and quality assurance criteria used in assembly, test, and checkout of these systems.

Panel specialists continued reviewing data from the mission with emphasis upon integrating various data points into logical failure mode patterns established by MSC and Board personnel.

MAY 3, 1970

Chairman Cortright and Board Members conducted a detailed review of individual Panel status and progress and established milestones for additional analytical work and preparation of preliminary findings.

The Board and Panel agreed to tentative report structure, including required exhibits, tables, drawings, and other reference data.

The Board established a system for tabulating all significant mission events and explanatory data, including the support tests required to clarify questions raised by events.

Panel Members worked on individual analyses with particular attention to developing requirements for additional test activity in support of tentative conclusions.

The Board agreed to strengthen its technical reviews of combustion propagation and electrical design by adding specialists in these areas.

MAY 4, 1970

The Design Panel continued its intensive review of the "shelf drop" incident at NR involving the cryogenic oxygen flight tank used in Apollo 13 in order to understand possible results of this event.

The Mission Events Panel continued to analyze telemetry data received by MSC, with particular attention on data received in proximity to the data dropout period during the Apollo 13 mission and on fan turnons during the flight.

The Board transmitted a formal listing of 62 requests for data, analyses, and support tests required for Board review activity.

The Board continued to meet with individual Panels and support offices to review the status of preliminary findings and work completed.

MAY 5, 1970

The Board met in General Session to discuss the scope and conduct of support test activity, including careful documentation of test methods and application of test results.

MSC personnel briefed Panel Members on availability of additional telemetry data in the MSC data bank in order to insure Board consideration of all possible useful data.

Panels commenced initial drafting of preliminary findings in specific areas, including summary descriptions of system performance during the Apollo 13 flight.

The Board met with the MSC Investigation Team for complete review of the proposed test program.

MAY 6, 1970

Board Members, MSC personnel, and Members of NASA's Aerospace Safety Advisory Panel met for detailed discussions and evaluation of accident review status and progress. The review covered oxygen tank questions, recovery operations, and a mission simulation by MSC astronauts.

Panel Members continued to work on the preparation of preliminary Panel drafts.

Chairman Cortright transmitted additional requests for tests to MSC and modified procedures for control of overall test activity relating to the Apollo 13 accident.

MAY 7, 1970

The General Board Session reviewed complete analysis and test support activities being conducted for the Board and MSC at various governmental and contractor installations.

Board and Panel Members met to discuss Ames laboratory tests concerning liquid oxygen combustion initiation energies required in the cryogenic oxygen tank used in the Apollo 13 SM.

Panel 1 Members reviewed mission control equipment and operating procedures used during the Apollo 13 mission and reviewed actual mission events in detail.

The Panels continued to develop preliminary drafts of their reviews and analyses for consideration by the Board.

MAY 8, 1970

Dr. Robert Van Dolah, Bureau of Mines, joined the Board as a consultant on combustion propagation and reviewed Apollo 13 Review Board data developed to date.

The General Board Session convened to review proposed report format and scope. An agreement was reached on appendices, on the structure of the report, and on the degree of detail to be included in individual Panel reports.

Chairman Cortright assigned additional specific test overview responsibilities to members of the Apollo 13 Review activity.

Panel 1 conducted a formal interview with the MSC Flight Director covering all significant mission events from the standpoint of ground controllers.

Panels 2 through 4 continued developing preliminary reports. Panel 4 announced a formal schedule of interviews of MSC, contractors, and NASA Headquarters personnel.

Board Members explored in detail possible failure mode sequences developed by MSC personnel involving ignition and combustion within the SM cryogenic oxygen tank.

The Board recessed for 3 days, leaving a cadre of personnel at MSC to edit preliminary drafts developed by the Panels and to schedule further activity for the week of May 11.

MAY 9, 1970

Board in recess.

MAY 10, 1970

Board in recess.

MAY 11, 1970

Board in recess. MSC support personnel continued work obtaining additional technical data for Board review.

MAY 12, 1970

Board Members returned to MSC.

Board Members attended a General Session to review progress and status of the report.

Panel Chairmen reported on individual progress of work and established schedules for completion of analyses and evaluations.

Chairman Cortright reported on the Langley Research Center support test program aimed at simulation of SM panel ejection energy pulses.

MAY 13, 1970

Board Members reviewed preliminary drafts of report chapter on Review and Analysis and Panel 1 report on Mission Events.

Mission Events Panel Members interviewed Electrical, Electronic, and Communications Engineer (EECOM) and one of the Apollo 13 Flight Directors on activities which took place in the Mission Control Center (MCC) during and after the flight accident period.

Panel 4, Project Management Panel, conducted interviews with principal Apollo 13 program personnel from MSC and contract organizations.

Panel Members continued drafting preliminary versions of Panel reports for review by the Board.

Manufacturing and Test Panel representatives discussed program for oxygen tank testing to be conducted at Beech Aircraft.

Board Members met in General Session to review report milestones and required test data for the week ahead.

MAY 14, 1970

Board met in General Session to review Panel report progress and to agree to firm schedules for completion of all Review Board assignments.

Project Management Panel continued to interview key Apollo project personnel from NASA Centers and contractors.

Panel Members circulated first drafts of all Panel reports to Board Members for review and correction.

MAY 15, 1970

Mission Events Panel personnel interviewed Apollo 13 Command Module Pilot John Swigert to verify event chronology compiled by the Panel and to review crew responses during Apollo 13 mission.

Project Management Panel continued interviewing key project personnel with NASA Centers and contractors.

MSC personnel provide Board Members and Panel Chairmen with a detailed briefing on all support tests and analyses being performed in connection with the MSC and Board reviews.

Board Members met in Executive Session to review preliminary drafts of Panel reports and findings and determinations and to provide additional instructions and guidance to Panel Chairmen.

Panel Members continued to review and edit early Panel drafts and to compile reference data in support of findings.

MAY 16, 1970

Board met in General Session to review further revisions of preliminary findings and determinations and to establish working schedules for completion of the Board report.

Panel Members continued to edit and refine Panel reports on basis of discussions with MSC personnel and further analysis of Apollo 13 documentation.

MAY 17, 1970

Draft material for all parts of Board report was reviewed by Panel Members and staff. Changes were incorporated in all draft material and recirculated for additional review and comment.

Board Members met in General Session to review report progress and to examine results from recent support tests and analyses being conducted at various Government and contractor installations.

The Apollo 13 Review Board discussed a continuing series of support tests for recommendation to MSC following presentation of report and recess of the Board.

MAY 18, 1970

Board Members reviewed Special Tests and Analyses Appendix of the report and examined results of completed tests.

Board met in General Session to discuss control procedures for reproduction and distribution of Board report.

Mission Events Panel distributed a final draft of their report for review by Board Members.

Board reviewed a preliminary draft of findings and determinations prepared by Panel Chairmen, Board Members, and Board Chairman.

A Manufacture and Test Panel representative reviewed special oxygen tank test programs at Beech Aircraft.

MAY 19, 1970

Board Members met in Executive Session to continue evaluation and assessment of preliminary findings, determinations, and recommendations prepared by individual Board Members and Panel Chairmen.

Board met in General Session to review final draft of Mission Events Panel report.

Manufacture and Test Panel preliminary report was distributed to Board Members for review and comment.

Design Panel preliminary report was distributed to Board Members for review and comment.

Design Panel Members met with MSC Team officials to discuss further test and analyses support for the Board.

MAY 20, 1970

Board Members met in Executive Session to review and evaluate reports from the Design Panel and from the Manufacturing and Test Panel.

Project Management Panel distributed final draft of its report to Board Members for review and comment.

Chairman Cortright met with Mr. Bruce Lundin of the Aerospace Safety Advisory Panel to discuss progress of Board review and analysis.

MAY 21, 1970

Board Members met in Executive Session for final review of Project Management Panel report.

Board Members and others met with MSC officials to review in detail the activities and actions taken after the Apollo 20⁴ accident concerning ignition flammability for materials and control in the CSM.

A third draft of preliminary findings, determinations, and recommendations was developed and circulated by the Chairman for review and comment.

Arrangements were made with NASA Headquarters officials for packaging, delivery, and distribution of the Board's final report.

Mission Events Panel conducted an interview with Lunar Module Pilot Haise to review selected mission events bearing on the accident.

MAY 22, 1970

Mission Events Panel representatives met with MSC officials to review in detail several events which occurred during later flight stages.

Board met in Executive Session to assess latest drafts of findings, determinations, and recommendations circulated by the Chairman.

Board met in General Session to review total progress in all report areas and to establish final schedule for preparation of Board report.

Langley Research Center representative M. Ellis briefed the Board on ignition and combustion of materials in oxygen atmosphere tests being conducted in support of the Apollo 13 Review.

Board Observer I. I. Pinkel briefed the Board on Lewis Research Center fire propagation tests involving Teflon.

MAY 23, 1970

Board Members reviewed Chapter 4 of Board report entitled "Review and Analysis."

Panel Chairmen reviewed draft findings and determinations prepared by the Board.

MAY 24, 1970

Board Members reviewed NASA Aerospace Safety Panel report covering Apollo activities during the period of 1968-69.

Board met in Executive Session for detailed review of support test status and progress and of documentation describing the results of test activity.

Board met in Executive Session for further review of findings, determinations, and recommendations.

MAY 25, 1970

Board met in Executive Session to review test progress and decided to postpone submittal of final report until June 8 in order to consider results of Langley Research Center panel ejection tests.

Board Members continued to review MSC Investigation Team preliminary drafts and refine Apollo 13 data in the various Board appendices.

Board met in Executive Session for further consideration of findings, determinations, and recommendations.

MAY 26, 1970

Board met in General Session and interviewed Astronaut James Lovell regarding crew understanding of inflight accident.

Board Members reviewed proposed MSC tank combustion test and agreed to test methodology and objectives.

Panel Members continued preparation of individual Panel reports.

MAY 27, 1970

Board and Panel Members received a detailed briefing on thermostatic switch failure during MSC heater tube temperature tests.

Aerospace Safety Advisory Panel met with Chairman Cortright, Board Members, and Panel Chairmen to review Board progress and status of findings and conclusions.

Board met in General Session to review status of Panel reports, documentation of test data and results, and plans for report typing and review.

Board agreed to recess for several days to accumulate additional test information on panel separation and full scale tank ignition data.

MAY 28, 1970

Board in recess.

MAY 29, 1970

Board in recess.

MAY 30, 1970

Board in recess.

MAY 31, 1970

Board in recess.

JUNE 1, 1970

Board Members returned to MSC.

Board and Panel Members met in General Session to discuss revisions of Panel reports in light of latest information regarding thermostatic switch failure during CDDT at KSC.

Board approved new schedule for Board report calling for final versions of Panel reports by Monday, June 8.

JUNE 2, 1970

Chairman Cortright briefed the Press on the status of the Board's work and future plans.

Board and Panel Members participated in a detailed interview and discussion with MSC and contractor personnel regarding specific coordination steps taken during oxygen tank no. 2 detanking operations at KSC.

Board Members met in Executive Session to review latest test results and to assess status of Board findings and determinations.

JUNE 3, 1970

Board and Panel Members met with MSC Program Office personnel for a detailed update of recent MSC information and analyses stemming from ongoing test programs.

Board Members and Panel Chairmen completed final reviews of Panel reports and also reviewed final draft of findings, determinations, and recommendations.

Board and Panel Members received a detailed briefing on thermostatic switch questions with emphasis upon actions of various organizations during and after detanking operations at KSC.

JUNE 4, 1970

Board Members met in Executive Session and completed final revisions of Chapter 4 of the Board summary.

Board and Panel Members witnessed a special full-scale tank ignition test performed at MSC.

Panel Chairmen completed final revisions of individual Panel reports and submitted copy to the Reports Editorial Office.

Board met in Executive Session and agreed to final schedule for report printing and delivery to the Administrator on June 15, 1970.

JUNE 5, 1970

Board Members met in Executive Session and completed work on Chapter 5 of the Board Summary Report (Findings, Determinations, and Recommendations).

Board Members reviewed final version of Project Management Panel report and authorized printing as Appendix E.

Board Members Hedrick and Mark completed final tabulation of test support activities performed for the Board.

Board Members reviewed films of special test activities performed at various NASA Centers.

JUNE 6, 1970

Board met in Executive Session throughout the day and completed its review of Chapter 5 of its report (Findings, Determinations, and Recommendations).

Board Members completed review of analyses to be incorporated in Appendix F, Special Tests and Analyses.

JUNE 7, 1970

The Board met in Executive Session and approved plans and schedules for final editorial review and publication of the Board report.

The Chairman recessed the Board until June 15 at which time the Board is scheduled to reconvene in Washington, D.C., to present its report to the NASA Administrator and Deputy Administrator.

This page left blank intentionally.

CHAPTER 3
DESCRIPTION OF APOLLO 13 SPACE VEHICLE
AND MISSION SUMMARY

This chapter is extracted from Mission Operation Report No. M-932-70, Revision 3, published by the Program and Special Reports Division (XP), Executive Secretariat, NASA Headquarters, Washington, D.C.

Discussion in this chapter is broken into two parts. Part 1 is designed to acquaint the reader with the flight hardware and with the mission monitoring, support, and control functions and capabilities. Part 2 describes the Apollo 13 mission and gives a mission sequence of events summary.

PART 1 APOLLO/SATURN V SPACE VEHICLE

The primary flight hardware of the Apollo Program consists of the Saturn V launch vehicle and Apollo spacecraft (fig. 3-1). Collectively, they are designated the Apollo/Saturn V space vehicle (SV). Selected major systems and subsystems of the space vehicle may be summarized as follows.

SATURN V LAUNCH VEHICLE

The Saturn V launch vehicle (LV) is designed to boost up to 300,000 pounds into a 105-nautical mile earth orbit and to provide for lunar payloads of over 100,000 pounds. The Saturn V LV consists of three propulsive stages (S-IC, S-II, S-IVB), two interstages, and an instrument unit (IU).

S-IC Stage

The S-IC stage (fig. 3-2) is a large cylindrical booster, 138 feet long and 33 feet in diameter, powered by five liquid propellant F-1 rocket engines. These engines develop a nominal sea level thrust total of approximately 7,650,000 pounds. The stage dry weight is approximately 288,000 pounds and the total loaded stage weight is approximately 5,031,500 pounds. The S-IC stage interfaces structurally and electrically with the S-II stage. It also interfaces structurally, electrically, and pneumatically with ground support equipment (GSE) through two umbilical service arms, three tail service masts, and certain electronic systems by antennas. The S-IC stage is instrumented for operational measurements or signals which are transmitted by its independent telemetry system.

S-II Stage

The S-II stage (fig. 3-3) is a large cylindrical booster, 81.5 feet long and 33 feet in diameter, powered by five liquid propellant J-2 rocket engines which develop a nominal vacuum thrust of 230,000 pounds each for a total of 1,150,000 pounds. Dry weight of the S-II stage is approximately 78,050 pounds. The stage approximate loaded gross weight is 1,075,000 pounds. The S-IC/S-II interstage weighs 10,460 pounds. The S-II stage is instrumented for operational and research and development measurements which are transmitted by its independent telemetry system. The S-II stage has structural and electrical interfaces with the S-IC and S-IVB stages, and electric, pneumatic, and fluid interfaces with GSE through its umbilicals and antennas.

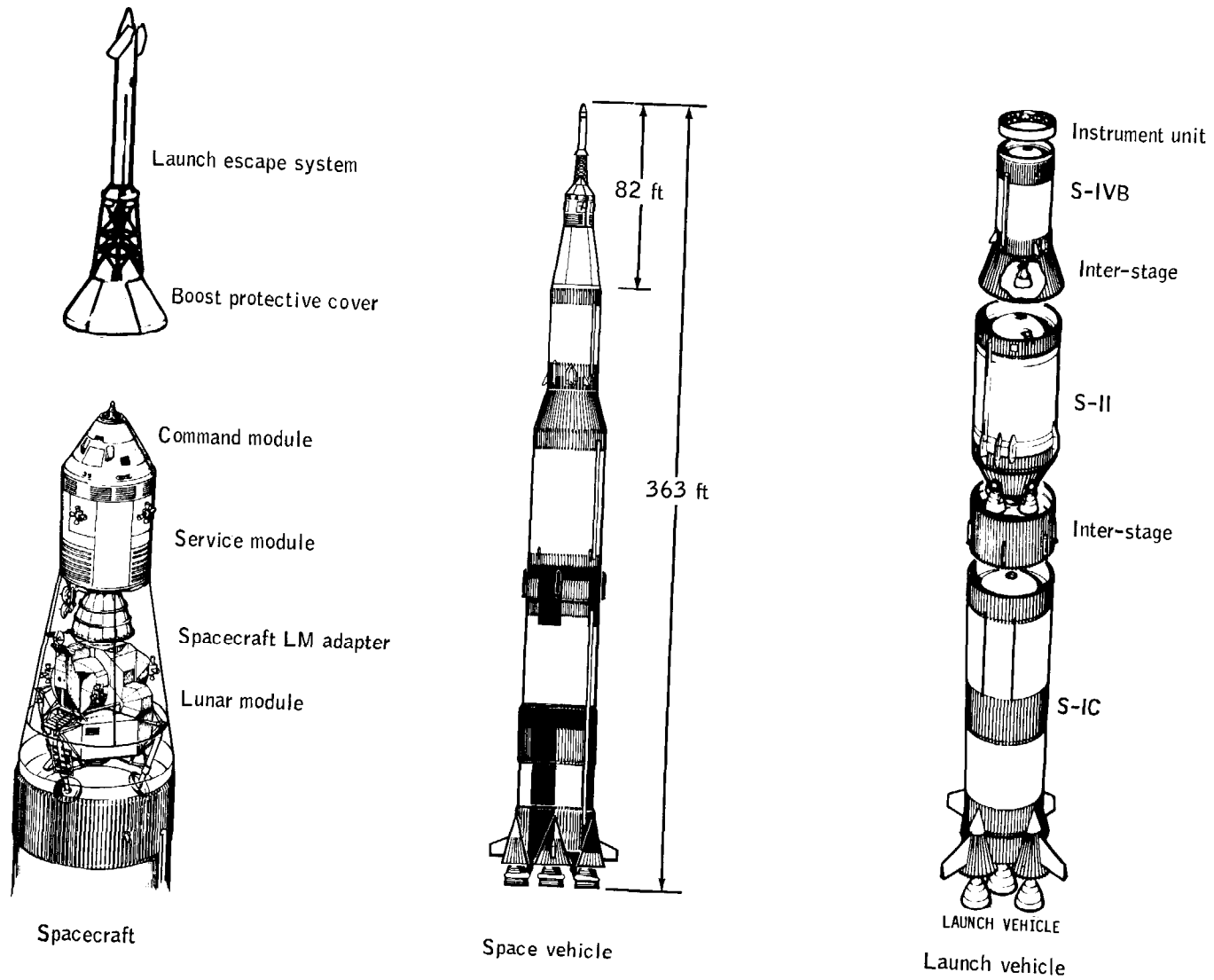

Figure 3-1.- Apollo/Saturn V space vehicle.

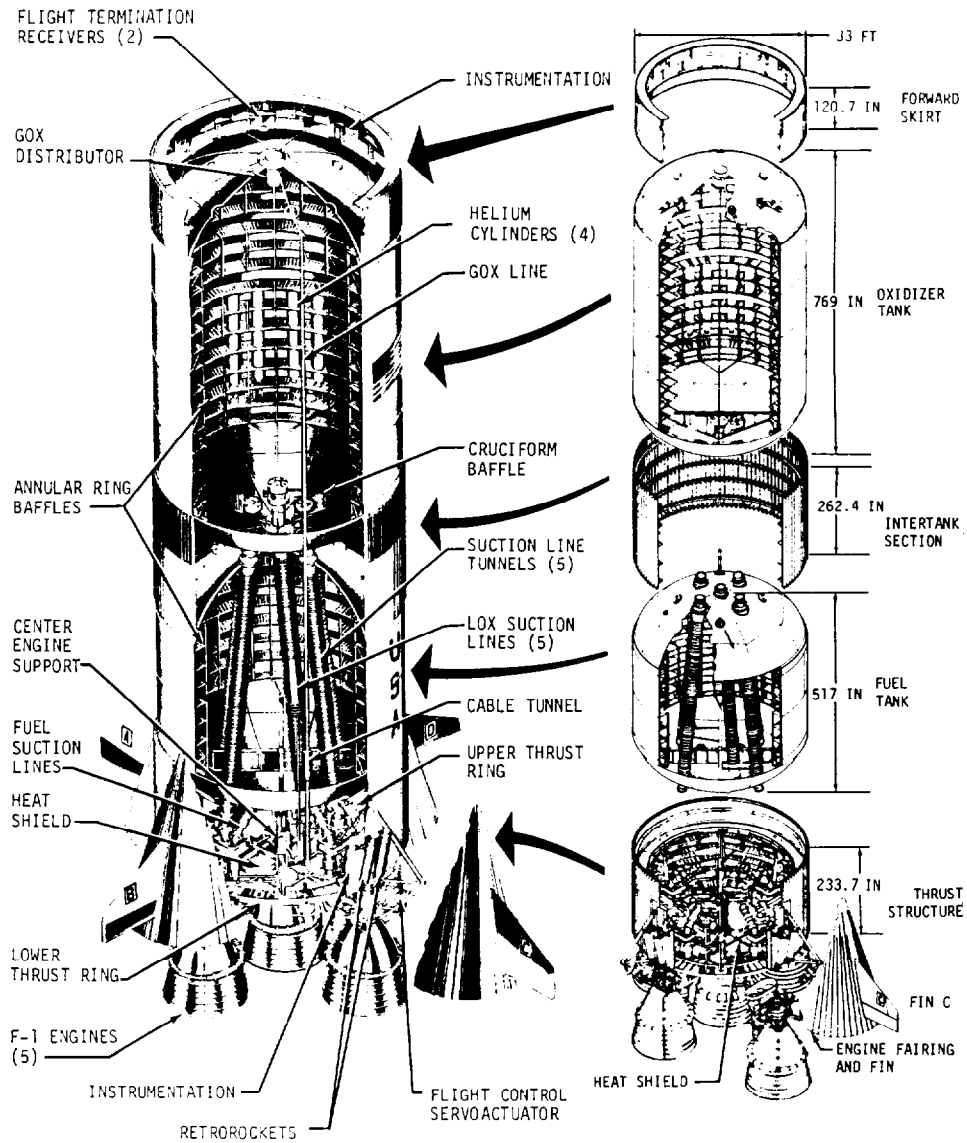

Figure 3-2.- S-IC stage.

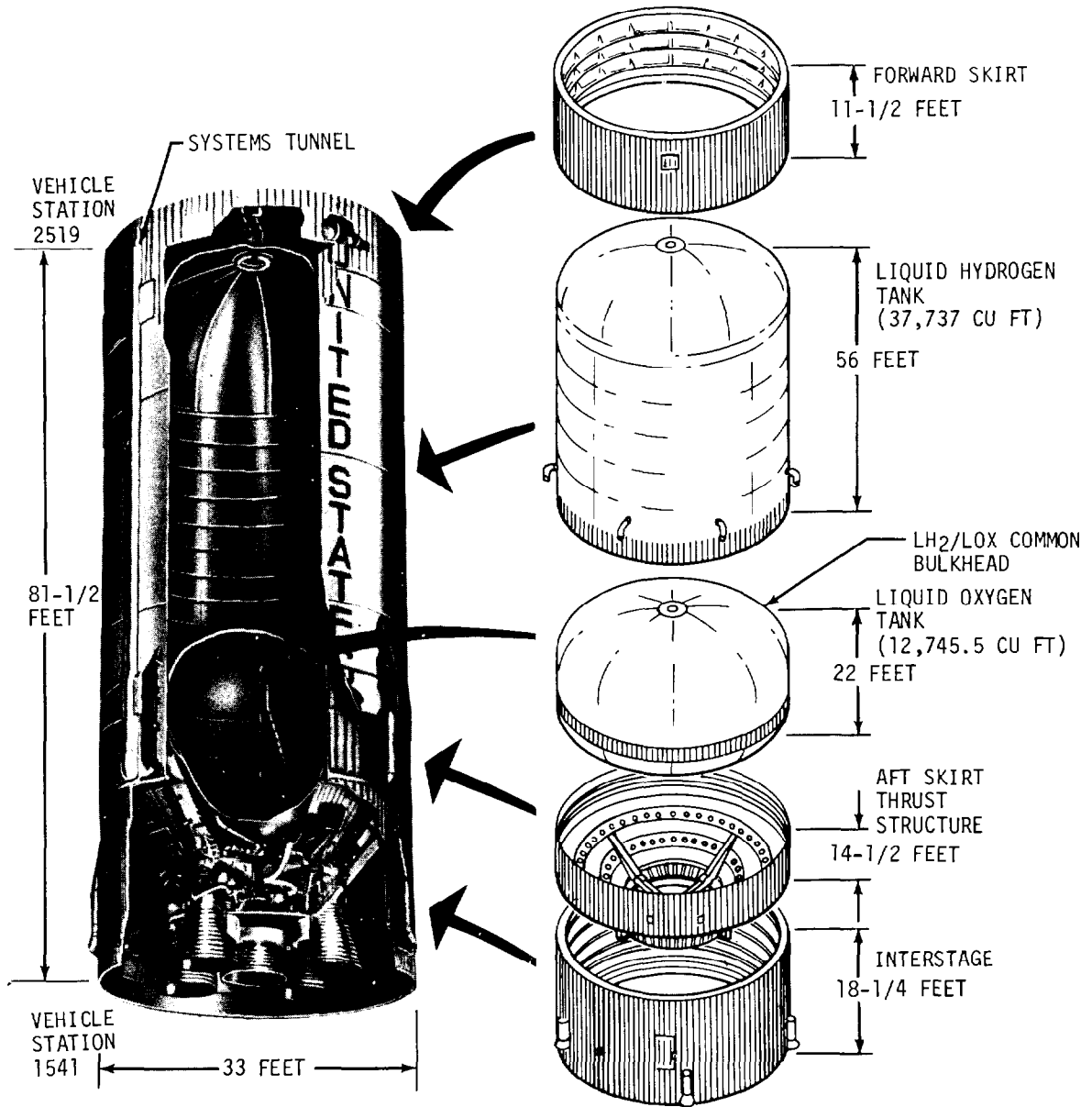

Figure 3-3.- S-II stage.

S-IVB Stage

The S-IVB stage (fig. 3-4) is a large cylindrical booster 59 feet long and 21.6 feet in diameter, powered by one J-2 engine. The S-IVB stage is capable of multiple engine starts. Engine thrust is 203,000 pounds. This stage is also unique in that it has an attitude control capability independent of its main engine. Dry weight of the stage is 25,050 pounds. The launch weight of the stage is 261,700 pounds. The interstage weight of 8100 pounds is not included in the stated weights. The stage is instrumented for functional measurements or signals which are transmitted by its independent telemetry system.

The high performance J-2 engine as installed in the S-IVB stage has a multiple start capability. The S-IVB J-2 engine is scheduled to produce a thrust of 203,000 pounds during its first burn to earth orbit and a thrust of 178,000 pounds (mixture mass ratio of 4.5:1) during the first 100 seconds of translunar injection. The remaining translunar injection acceleration is provided at a thrust level of 203,000 pounds (mixture mass ratio of 5.0:1). The engine valves are controlled by a pneumatic system powered by gaseous helium which is stored in a sphere inside a start bottle. An electrical control system that uses solid stage logic elements is used to sequence the start and shutdown operations of the engine.

Instrument Unit

The Saturn V launch vehicle is guided from its launch pad into earth orbit primarily by navigation, guidance, and control equipment located in the instrument unit (IU). The instrument unit is a cylindrical structure 21.6 feet in diameter and 3 feet high installed on top of the S-IVB stage. The unit weighs 4310 pounds and contains measurements and telemetry, command communications, tracking, and emergency detection system components along with supporting electrical power and the environmental control system.

APOLLO SPACECRAFT

The Apollo spacecraft (S/C) is designed to support three men in space for periods up to 2 weeks, docking in space, landing on and returning from the lunar surface, and safely entering the earth's atmosphere. The Apollo S/C consists of the spacecraft-to-IM adapter (SLA), the service module (SM), the command module (CM), the launch escape system (LES), and the lunar module (LM). The CM and SM as a unit are referred to as the command and service module (CSM).

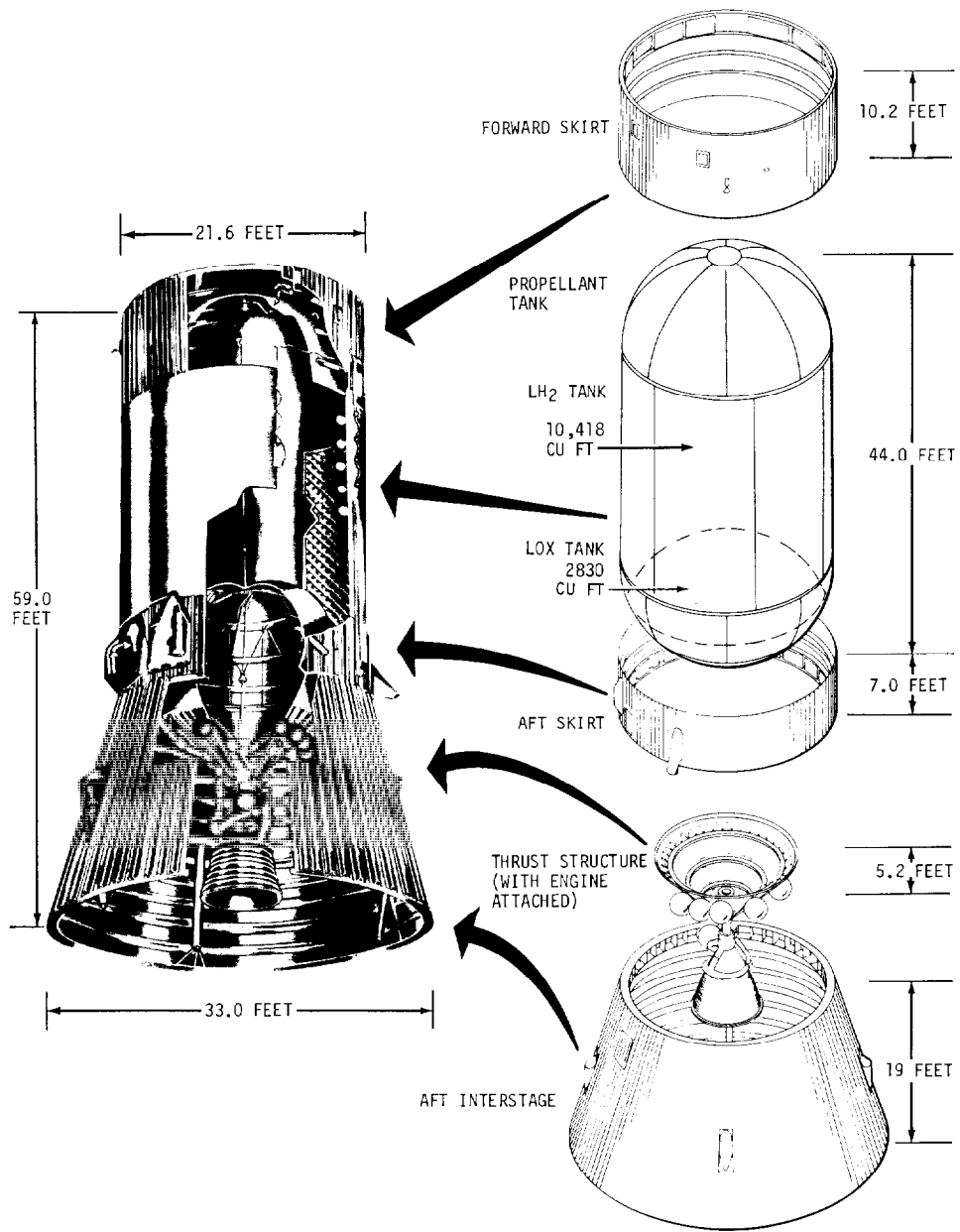

Figure 3-4.- S-IVB stage.

Spacecraft-to-LM Adapter

The SLA (fig. 3-5) is a conical structure which provides a structural load path between the LV and SM and also supports the LM. Aerodynamically, the SLA smoothly encloses the irregularly shaped LM and transitions the space vehicle diameter from that of the upper stage of the LV to that of the SM. The SLA also encloses the nozzle of the SM engine and the high gain antenna.

Spring thrusters are used to separate the LM from the SLA. After the CSM has docked with the LM, mild charges are fired to release the four adapters which secure the LM in the SLA. Simultaneously, four spring thrusters mounted on the lower (fixed) SLA panels push against the LM landing gear truss assembly to separate the spacecraft from the launch vehicle.

Service Module

The service module (SM)(fig. 3-6) provides the main spacecraft propulsion and maneuvering capability during a mission. The SM provides most of the spacecraft consumables (oxygen, water, propellant, and hydrogen) and supplements environmental, electrical power, and propulsion requirements of the CM. The SM remains attached to the CM until it is jettisoned just before CM atmospheric entry.

Structure.- The basic structural components are forward and aft (upper and lower) bulkheads, six radial beams, four sector honeycomb panels, four reaction control system honeycomb panels, aft heat shield, and a fairing. The forward and aft bulkheads cover the top and bottom of the SM. Radial beam trusses extending above the forward bulkhead support and secure the CM. The radial beams are made of solid aluminum alloy which has been machined and chem-milled to thicknesses varying between 2 inches and 0.018 inch. Three of these beams have compression pads and the other three have shear-compression pads and tension ties. Explosive charges in the center sections of these tension ties are used to separate the CM from the SM.

An aft heat shield surrounds the service propulsion engine to protect the SM from the engine's heat during thrusting. The gap between the CM and the forward bulkhead of the SM is closed off with a fairing which is composed of eight electrical power system radiators alternated with eight aluminum honeycomb panels. The sector and reaction control system panels are 1 inch thick and are made of aluminum honeycomb core between two aluminum face sheets. The sector panels are bolted to the radial beams. Radiators used to dissipate heat from the environmental control subsystem are bonded to the sector panels on opposite sides of the SM. These radiators are each about 30 square feet in area.

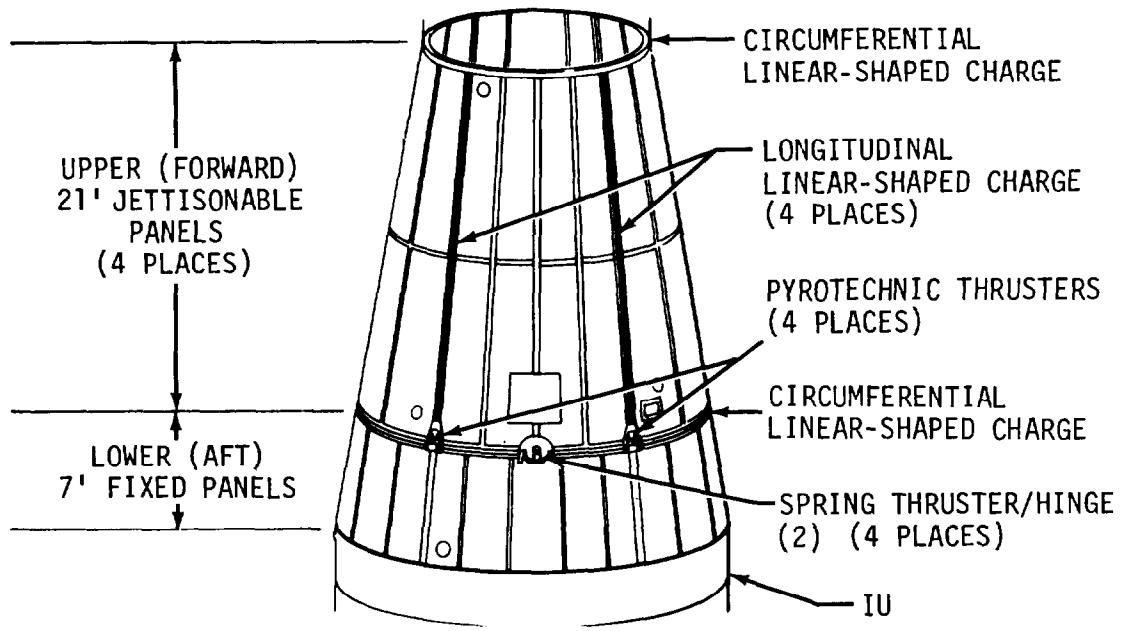

Figure 3-5.- Spacecraft-to-LM adapter.

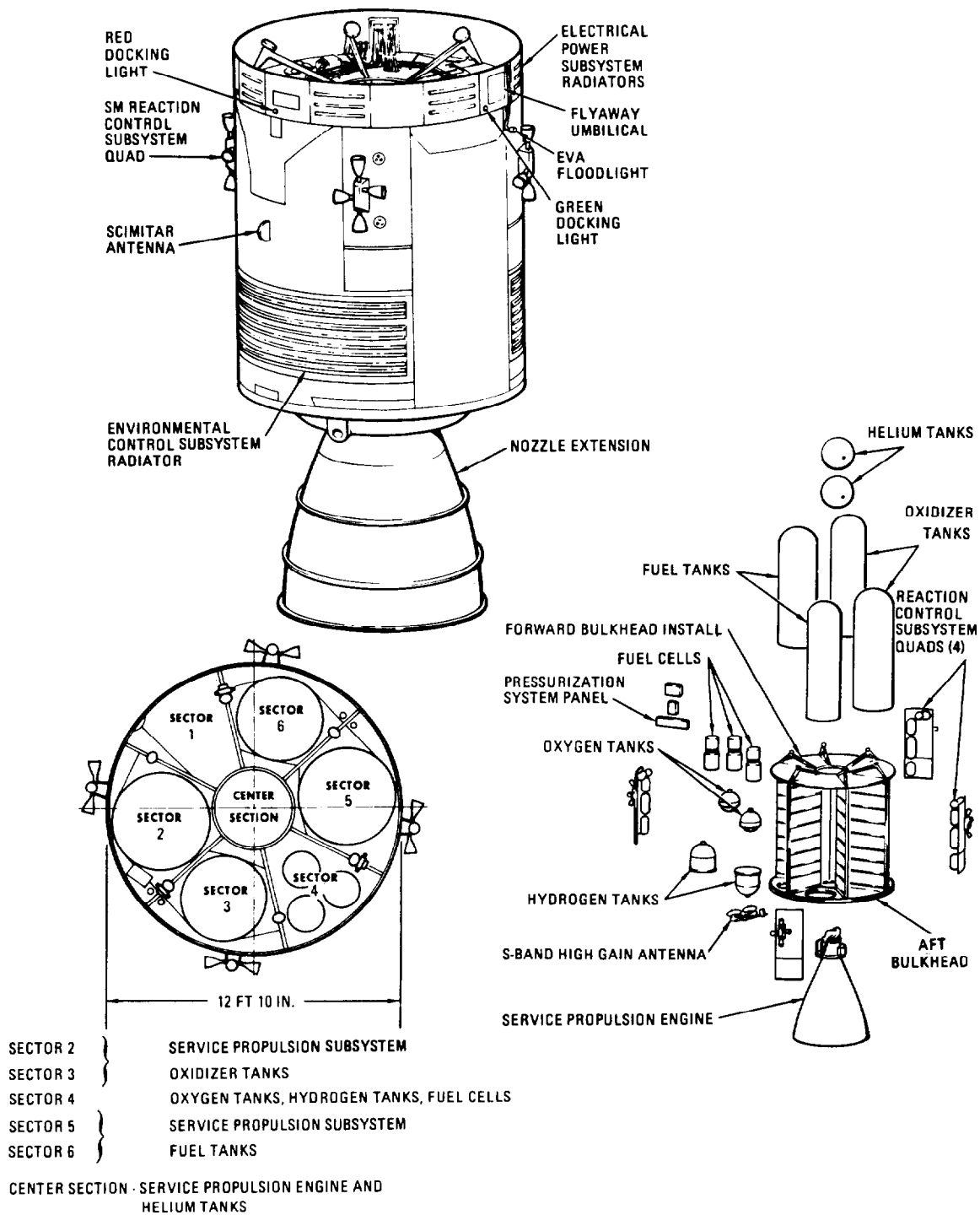

Figure 3-6.- Service module.

The SM interior is divided into six sectors, or bays, and a center section. Sector one is currently void. It is available for installation of scientific or additional equipment should the need arise. Sector two has part of a space radiator and a reaction control system (RCS) engine quad (module) on its exterior panel and contains the service propulsion system (SPS) oxidizer sump tank. This tank is the larger of the two tanks that hold the oxidizer for the SPS engine. Sector three has the rest of the space radiator and another RCS engine quad on its exterior panel and contains the oxidizer storage tank. This tank is the second of two SPS oxidizer tanks and feeds the oxidizer sump tank in sector two. Sector four contains most of the electrical power generating equipment. It contains three fuel cells, two cryogenic oxygen and two cryogenic hydrogen tanks, and a power control relay box. The cryogenic tanks supply oxygen to the environmental control subsystem and oxygen and hydrogen to the fuel cells. Sector five has part of an environmental control radiator and an RCS engine quad on the exterior panel and contains the SPS engine fuel sump tank. This tank feeds the engine and is also connected by feed lines to the storage tank in sector six. Sector six has the rest of the environmental control radiator and an RCS engine quad on its exterior and contains the SPS engine fuel storage tank which feeds the fuel sump tank in sector five. The center section contains two helium tanks and the SPS engine. The tanks are used to provide helium pressurant for the SPS propellant tanks.

Propulsion.- Main spacecraft propulsion is provided by the 20500-pound thrust SPS. The SPS engine is a restartable, non-throttleable engine which uses nitrogen tetroxide (N_2O_4) as an oxidizer and a 50-50 mixture of hydrazine and unsymmetrical-dimethylhydrazine (UDMH) as fuel. (These propellants are hypergolic, i.e., they burn spontaneously when combined without need for an igniter.) This engine is used for major velocity changes during the mission, such as midcourse corrections, lunar orbit insertion, transearth injection, and CSM aborts. The SPS engine responds to automatic firing commands from the guidance and navigation system or to commands from manual controls. The engine assembly is gimbal-mounted to allow engine thrust-vector alignment with the spacecraft center of mass to preclude tumbling. Thrust-vector alignment control is maintained by the crew. The SM RCS provides for maneuvering about and along three axes.

Additional SM systems.- In addition to the systems already described, the SM has communication antennas, umbilical connections, and several exterior mounted lights. The four antennas on the outside of the SM are the steerable S-band high-gain antenna, mounted on the aft bulkhead; two VHF omnidirectional antennas, mounted on opposite sides of the module near the top; and the rendezvous radar transponder antenna, mounted in the SM fairing.

Seven lights are mounted in the aluminum panels of the fairing. Four lights (one red, one green, and two amber) are used to aid the astronauts in docking: one is a floodlight which can be turned on to give astronauts visibility during extravehicular activities, one is a flashing beacon used to aid in rendezvous, and one is a spotlight used in rendezvous from 500 feet to docking with the LM.

SM/CM separation.- Separation of the SM from the CM occurs shortly before entry. The sequence of events during separation is controlled automatically by two redundant service module jettison controllers (SMJC) located on the forward bulkhead of the SM.

Command Module

The command module (CM) (fig. 3-7) serves as the command, control, and communications center for most of the mission. Supplemented by the SM, it provides all life support elements for three crewmen in the mission environments and for their safe return to the earth's surface. It is capable of attitude control about three axes and some lateral lift translation at high velocities in earth atmosphere. It also permits LM attachment, CM/LM ingress and egress, and serves as a buoyant vessel in open ocean.

Structure.- The CM consists of two basic structures joined together: the inner structure (pressure shell) and the outer structure (heat shield). The inner structure, the pressurized crew compartment, is made of aluminum sandwich construction consisting of a welded aluminum inner skin, bonded aluminum honeycomb core, and outer face sheet. The outer structure is basically a heat shield and is made of stainless steel-brazed honeycomb brazed between steel alloy face sheets. Parts of the area between the inner and outer sheets are filled with a layer of fibrous insulation as additional heat protection.

Display and controls.- The main display console (MDC) (fig. 3-8) has been arranged to provide for the expected duties of crew members. These duties fall into the categories of Commander, CM Pilot, and LM Pilot, occupying the left, center, and right couches, respectively. The CM Pilot also acts as the principal navigator. All controls have been designed so they can be operated by astronauts wearing gloves. The controls are predominantly of four basic types: toggle switches, rotary switches with click-stops, thumb-wheels, and push buttons. Critical switches are guarded so that they cannot be thrown inadvertently. In addition, some critical controls have locks that must be released before they can be operated.

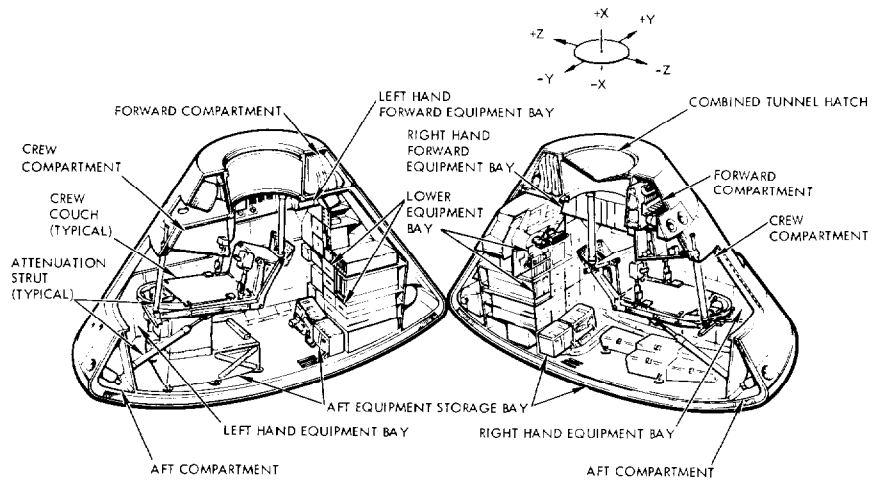
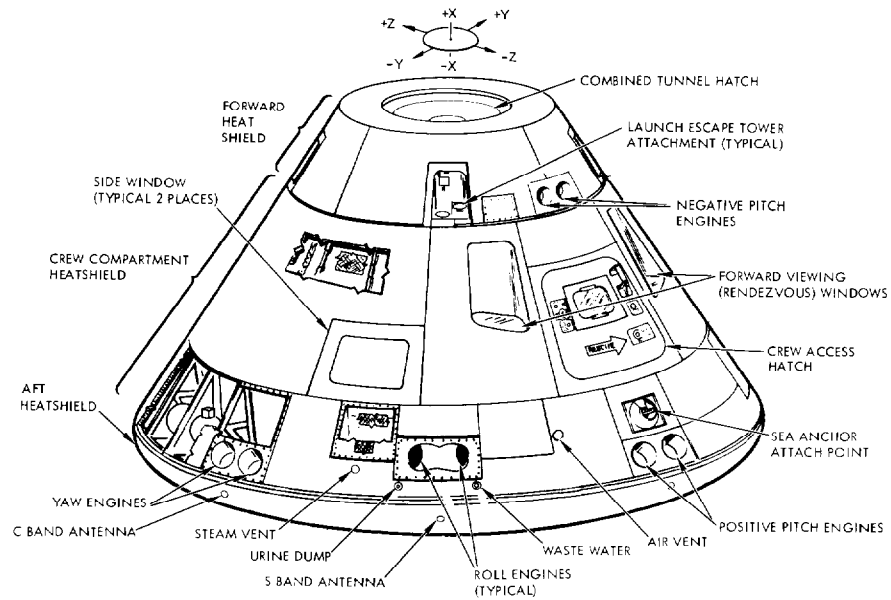
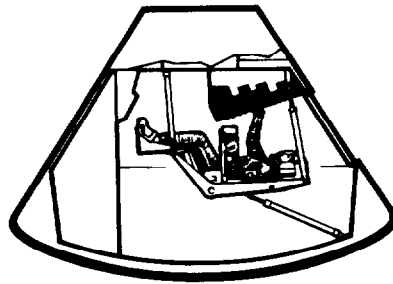
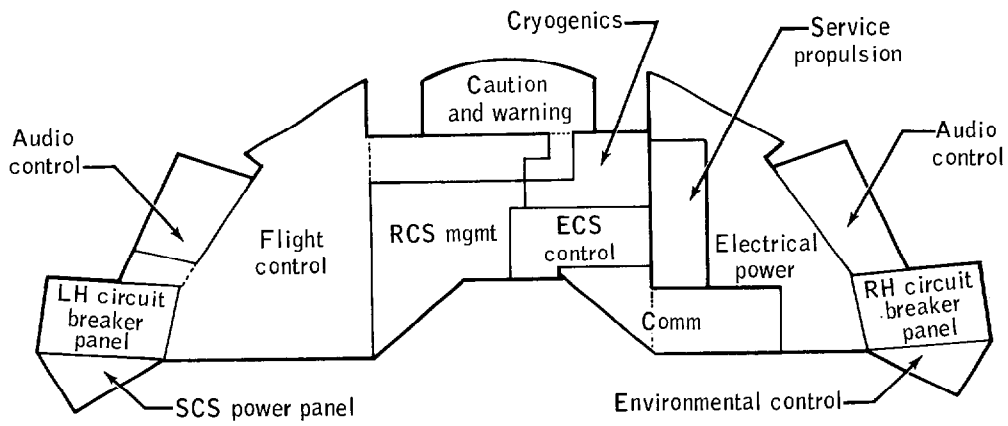

Figure 3-7.- Command module.



- Launch vehicle emergency detection
- Flight attitude
- Mission sequence
- Velocity change monitor
- Entry monitor
- Propellant gauging
- Environment control
- Communications control
- Power distribution
- Caution and warning

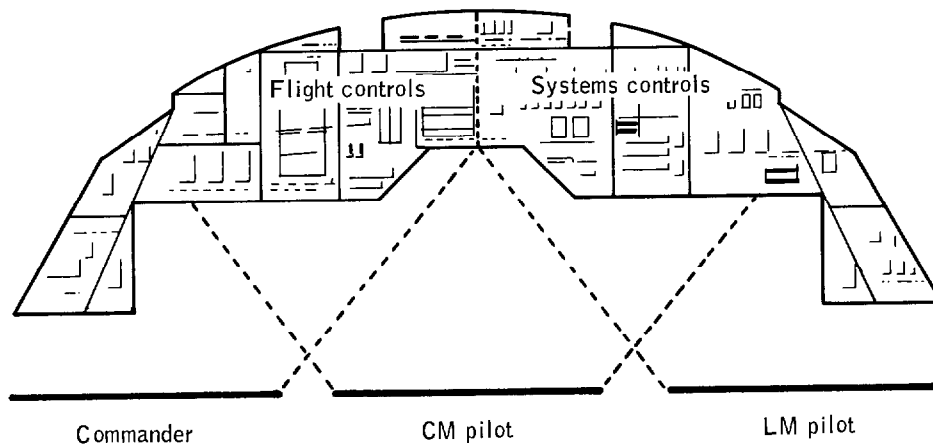

Figure 3-8.- CM main display console.

Flight controls are located on the left center and left side of the MDC, opposite the Commander. These include controls for such subsystems as stabilization and control, propulsion, crew safety, earth landing, and emergency detection. One of two guidance and navigation computer panels also is located here, as are velocity, attitude, and altitude indicators.

The CM Pilot faces the center of the console, and thus can reach many of the flight controls, as well as the system controls on the right side of the console. Displays and controls directly opposite him include reaction control, propellant management, caution and warning, environmental control, and cryogenic storage systems. The rotation and translation controllers used for attitude, thrust vector, and translation maneuvers are located on the arms of two crew couches. In addition, a rotation controller can be mounted at the navigation position in the lower equipment bay.

Critical conditions of most spacecraft systems are monitored by a caution and warning system. A malfunction or out-of-tolerance condition results in illumination of a status light that identifies the abnormality. It also activates the master alarm circuit, which illuminates two master alarm lights on the MDC and one in the lower equipment bay and sends an alarm tone to the astronauts' headsets. The master alarm lights and tone continue until a crewman resets the master alarm circuit. This can be done before the crewmen deal with the problem indicated. The caution and warning system also contains equipment to sense its own malfunctions.

Lunar Module

The lunar module (LM) (fig. 3-9) is designed to transport two men safely from the CSM, in lunar orbit, to the lunar surface, and return them to the orbiting CSM. The LM provides operational capabilities such as communications, telemetry, environmental support, transportation of scientific equipment to the lunar surface, and returning surface samples with the crew to the CSM.

The lunar module consists of two stages: the ascent stage and the descent stage. The stages are attached at four fittings by explosive bolts. Separable umbilicals and hardline connections provide subsystem continuity to operate both stages as a single unit until separate ascent stage operation is desired. The LM is designed to operate for 48 hours after separation from the CSM, with a maximum lunar stay time of 44 hours. Table 3-1 is a weight summary of the Apollo/Saturn 5 space vehicle for the Apollo 13 mission.

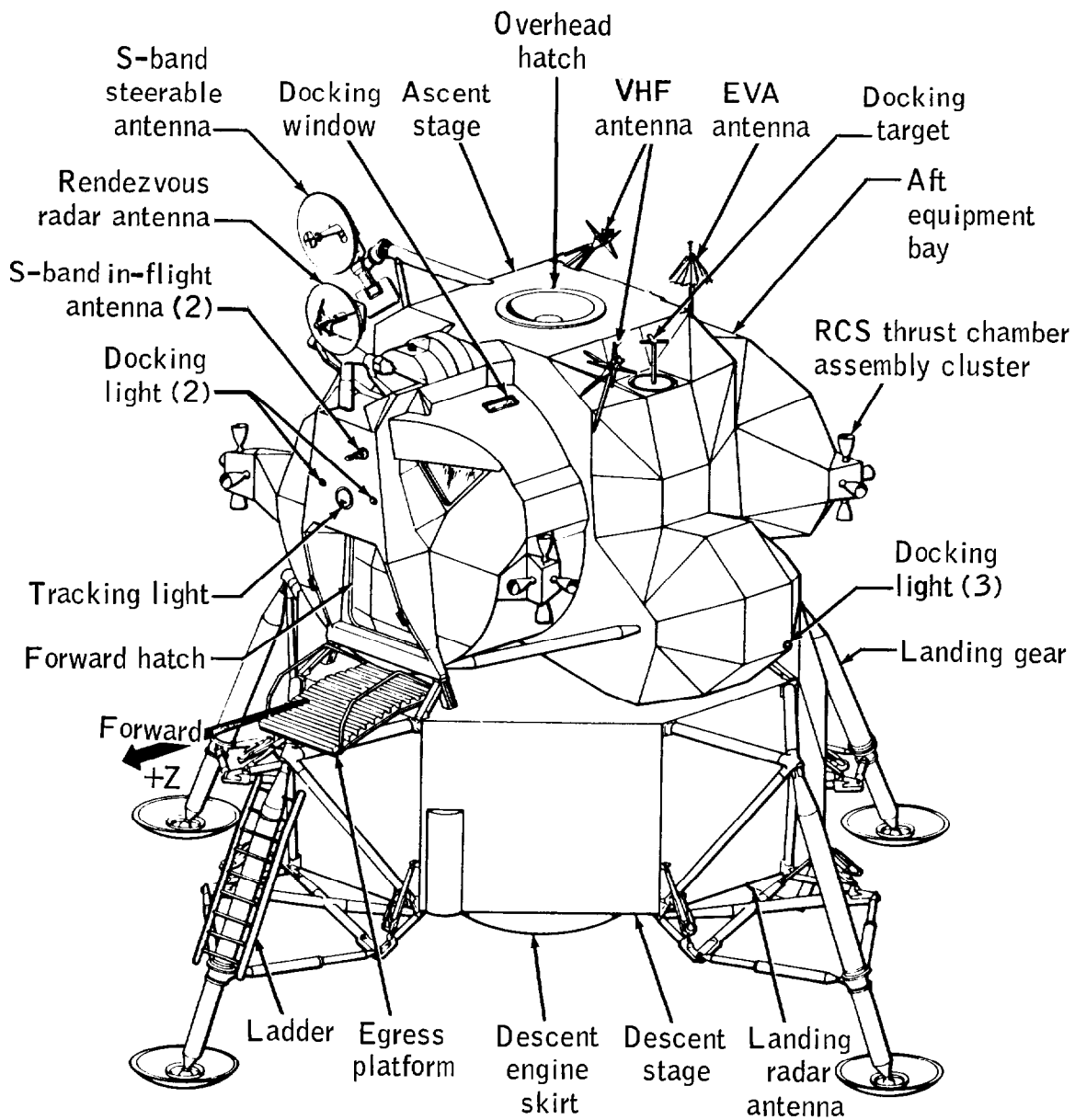

Figure 3-9.- Lunar module.

TABLE 3-I.- APOLLO 13 WEIGHT SUMMARY (WEIGHT IN POUNDS)

Stage/module	Inert weight	Total expendables	Total weight	Final separation weight
S-IC	288000	4746870	5034870	363403
S-IC/S-II interstage	11464	---	11464	---
S-II stage	78050	996960	1075010	92523
S-II/S-IVB interstage	8100	---	8100	---
S-IVB stage	25050	236671	261721	35526
Instrument unit	4482	---	4482	---
Launch vehicle at ignition 6,395,647				
Spacecraft-LM adapter	4044	---	4044	---
Lunar module	9915	23568	33483	*33941
Service module	10532	40567	51099	**14076
Command module	12572	---	12572	**11269 (Landing)
Launch escape system	9012	---	9012	---

* CSM/LM separation
 ** CM/SM separation

TABLE 3-I.- APOLLO 13 WEIGHT SUMMARY (WEIGHT IN POUNDS) - Concluded

Stage/module	Inert weight	Total expendables	Total weight	Final separation weight
Spacecraft at ignition 110,210				
Space vehicle at ignition			6505857	
S-IC thrust buildup			(-)84598	
Space vehicle at lift-off			6421259	
Space vehicle at orbit insertion			299998	

Main propulsion.- Main propulsion is provided by the descent propulsion system (DPS) and the ascent propulsion system (APS). Each system is wholly independent of the other. The DPS provides the thrust to control descent to the lunar surface. The APS can provide the thrust for ascent from the lunar surface. In case of mission abort, the APS and/or DPS can place the LM into a rendezvous trajectory with the CSM from any point in the descent trajectory. The choice of engine to be used depends on the cause for abort, on how long the descent engine has been operating, and on the quantity of propellant remaining in the descent stage. Both propulsion systems use identical hypergolic propellants. The fuel is a 50-50 mixture of hydrazine and unsymmetrical-dimethylhydrazine and the oxidizer is nitrogen tetroxide. Gaseous helium pressurizes the propellant feed systems. Helium storage in the DPS is at cryogenic temperatures in the super-critical state and in the APS it is gaseous at ambient temperatures.

Ullage for propellant settling is required prior to descent engine start and is provided by the +X axis reaction engines. The descent engine is gimballed, throttleable, and restartable. The engine can be throttled from 1050 pounds of thrust to 6300 pounds. Throttle positions above this value automatically produce full thrust to reduce combustion chamber erosion. Nominal full thrust is 9870 pounds. Gimbal trim of the engine compensates for a changing center of gravity of the vehicle and is automatically accomplished by either the primary guidance and navigation system (PGNS) or the abort guidance system (AGS). Automatic throttle and on/off control is available in the PGNS mode of operation.

The AGS commands on/off operation but has no automatic throttle control capability. Manual control capability of engine firing functions has been provided. Manual thrust control override may, at any time, command more thrust than the level commanded by the LM guidance computer (LGC).

The ascent engine is a fixed, non-throttleable engine. The engine develops 3500 pounds of thrust, sufficient to abort the lunar descent or to launch the ascent stage from the lunar surface and place it in the desired lunar orbit. Control modes are similar to those described for the descent engine. The APS propellant is contained in two spherical titanium tanks, one for oxidizer and the other for fuel. Each tank has a volume of 36 cubic feet. Total fuel weight is 2008 pounds, of which 71 pounds are unusable. Oxidizer weight is 3170 pounds, of which 92 pounds are unusable. The APS has a limit of 35 starts, must have a propellant bulk temperature between 50° F and 90° F prior to start, must not exceed 460 seconds of burn time, and has a system life of 24 hours after pressurization.

Electrical power system.- The electrical power system (EPS) contains six batteries which supply the electrical power requirements of the LM during undocked mission phases. Four batteries are located in the descent stage and two in the ascent stage. Batteries for the explosive devices system are not included in this system description. Postlaunch LM power is supplied by the descent stage batteries until the LM and CSM are docked. While docked, the CSM supplies electrical power to the LM up to 296 watts (peak). During the lunar descent phase, the two ascent stage batteries are paralleled with the descent stage batteries for additional power assurance. The descent stage batteries are utilized for LM lunar surface operations and checkout. The ascent stage batteries are brought on the line just before ascent phase staging. All batteries and busses may be individually monitored for load, voltage, and failure. Several isolation and combination modes are provided.

Two inverters, each capable of supplying full load, convert the dc to ac for 115-volt, 400-hertz supply. Electrical power is distributed by the following busses: LM Pilot's dc bus, Commander's dc bus, and ac busses A and B.

The four descent stage silver-zinc batteries are identical and have a 400 ampere-hour capacity at 28 volts. Because the batteries do not have a constant voltage at various states of charge/load levels, "high" and "low" voltage taps are provided for selection. The "low voltage" tap is selected to initiate use of a fully charged battery. Cross-tie circuits in the busses facilitate an even discharge of the batteries regardless of distribution combinations. The two silver-zinc ascent stage batteries are identical to each other and have a 296 ampere-hour

capacity at 28 volts. The ascent stage batteries are normally connected in parallel for even discharge. Because of design load characteristics, the ascent stage batteries do not have and do not require high and low voltage taps.

Nominal voltage for ascent stage and descent stage batteries is 30.0 volts. Reverse current relays for battery failure are one of many components designed into the EPS to enhance EPS reliability. Cooling of the batteries is provided by the environmental control system cold rail heat sinks. Available ascent electrical energy is 17.8 kilowatt hours at a maximum drain of 50 amps per battery and descent energy is 46.9 kilowatt hours at a maximum drain of 25 amps per battery.

MISSION MONITORING, SUPPORT, AND CONTROL

Mission execution involves the following functions: prelaunch checkout and launch operations; tracking the space vehicle to determine its present and future positions; securing information on the status of the flight crew and space vehicle systems (via telemetry); evaluation of telemetry information; commanding the space vehicle by transmitting real-time and updata commands to the onboard computer; and voice communication between flight and ground crews.

These functions require the use of a facility to assemble and launch the space vehicle (see Launch Complex), a central flight control facility, a network of remote stations located strategically around the world, a method of rapidly transmitting and receiving information between the space vehicle and the central flight control facility, and a real-time data display system in which the data are made available and presented in usable form at essentially the same time that the data event occurred.

The flight crew and the following organizations and facilities participate in mission control operations:

- a. Mission Control Center (MCC), Manned Spacecraft Center (MSC), Houston, Texas. The MCC contains the communication, computer display, and command systems to enable the flight controllers to effectively monitor and control the space vehicle.
- b. Kennedy Space Center (KSC), Cape Kennedy, Florida. The space vehicle is launched from KSC and controlled from the Launch Control Center (LCC). Prelaunch, launch, and powered flight data are collected at the Central Instrumentation Facility (CIF) at KSC from the launch pads, CIF receivers, Merritt Island Launch Area (MILA), and the down-range Air Force Eastern Test Range (AFETR) stations. These data are

transmitted to MCC via the Apollo Launch Data System (ALDS). Also located at KSC (AFETR) is the Impact Predictor (IP), for range safety purposes.

c. Goddard Space Flight Center (GSFC), Greenbelt, Maryland. GSFC manages and operates the Manned Space Flight Network (MSFN) and the NASA communications (NASCOM) network. During flight, the MSFN is under the operational control of the MCC.

d. George C. Marshall Space Flight Center (MSFC), Huntsville, Alabama. MSFC, by means of the Launch Information Exchange Facility (LIEF) and the Huntsville Operations Support Center (HOSC) provides launch vehicle systems real-time support to KSC and MCC for preflight, launch, and flight operations.

A block diagram of the basic flight control interfaces is shown in figure 3-10.

Vehicle Flight Control Capability

Flight operations are controlled from the MCC. The MCC has two flight control rooms, but only one control room is used per mission. Each control room, called a Mission Operations Control Room (MOCR), is capable of controlling individual Staff Support Rooms (SSR's) located adjacent to the MOCR. The SSR's are manned by flight control specialists who provide detailed support to the MOCR. Figure 3-11 outlines the organization of the MCC for flight control and briefly describes key responsibilities. Information flow within the MOCR is shown in figure 3-12.

The consoles within the MOCR and SSR's permit the necessary interface between the flight controllers and the spacecraft. The displays and controls on these consoles and other group displays provide the capability to monitor and evaluate data concerning the mission and, based on these evaluations, to recommend or take appropriate action on matters concerning the flight crew and spacecraft.

Problems concerning crew safety and mission success are identified to flight control personnel in the following ways:

- a. Flight crew observations
- b. Flight controller real-time observations
- c. Review of telemetry data received from tape recorder playback
- d. Trend analysis of actual and predicted values

- e. Review of collected data by systems specialists
- f. Correlation and comparison with previous mission data
- g. Analysis of recorded data from launch complex testing

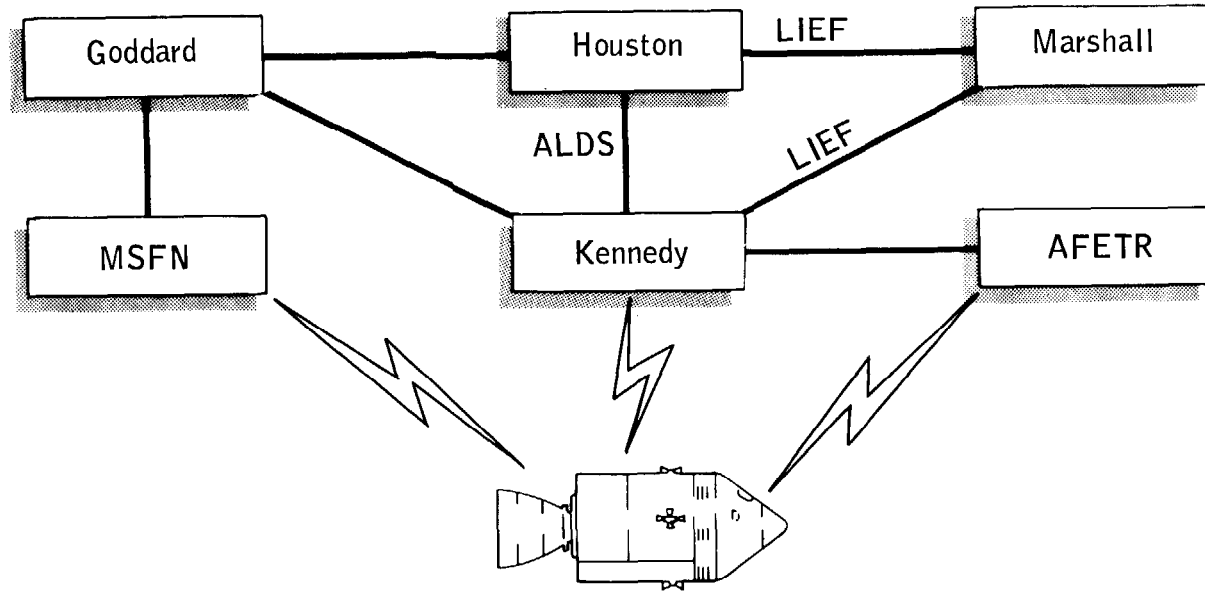

ALDS - Apollo Launch Data System
LIEF - Launch Information Exchange Facility

Figure 3-10.- Basic telemetry, command, and communication interfaces for flight control.

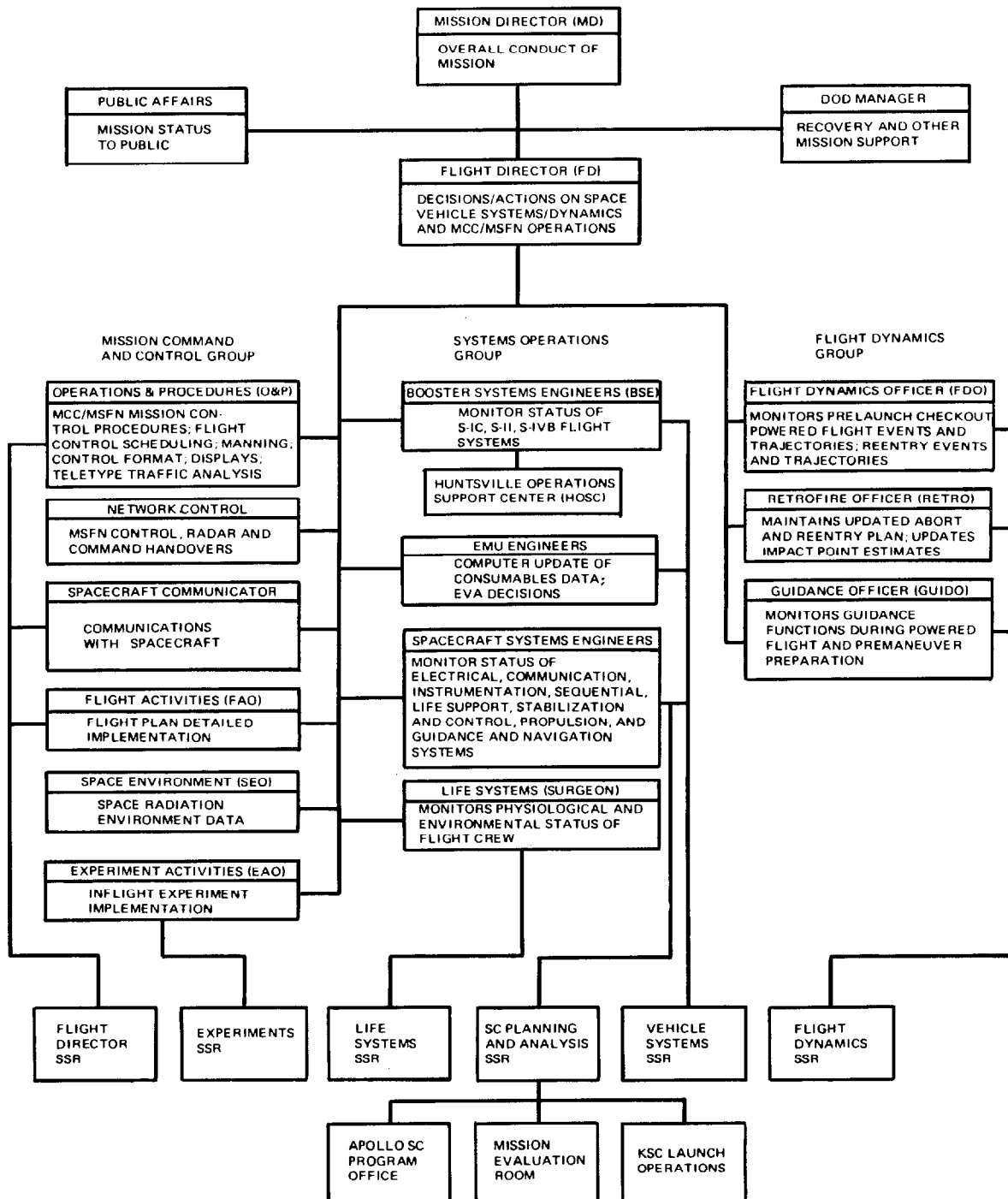

Figure 3-11.- Mission Control Center organization.

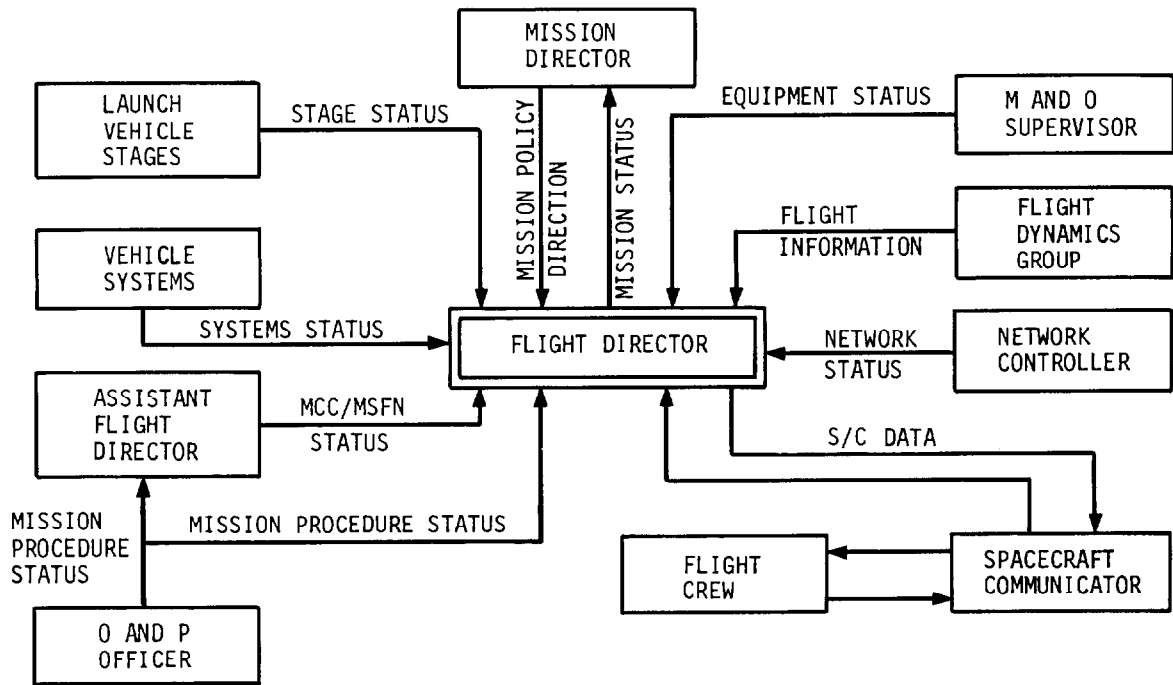

Figure 3-12.- Information flow within the Mission Operations Control Room.

PART 2. APOLLO 13 MISSION DESCRIPTION

PRIMARY MISSION OBJECTIVES

The primary mission objectives were as follows:

Perform selenological inspection, survey, and sampling of materials in a preselected region of the Fra Mauro Formation.

Deploy and activate an Apollo Lunar Surface Experiments Package (ALSEP).

Develop man's capability to work in the lunar environment.

Obtain photographs of candidate exploration sites.

Table 3-II lists the Apollo 13 mission sequence of major events and the time of occurrence in ground elapsed time.

TABLE 3-II. - APOLLO 13 MISSION SEQUENCE OF EVENTS

Event	Ground elapsed time (hr:min:sec)
Range zero (02:13:00.0 p.m. e.s.t., April 11)	00:00:00
Earth parking orbit insertion	00:12:40
Second S-IVB ignition	02:35:46
Translunar injection	02:41:47
CSM/S-IVB separation	03:06:39
Spacecraft ejection from S-IVB	04:01:03
S-IVB APS evasive maneuver	04:18:01
S-IVB APS maneuver for lunar impact	05:59:59
Midcourse correction - 2 (hybrid transfer)	30:40:50
Cryogenic oxygen tank anomaly	55:54:53
Midcourse correction - 4	61:29:43
S-IVB lunar impact	77:56:40
Pericyynthion plus 2-hour maneuver	79:27:39
Midcourse correction - 5	105:18:32
Midcourse correction - 7	137:39:49
Service module jettison	138:02:06
Lunar module jettison	141:30:02
Entry interface	142:40:47
Landing	142:54:41

Launch and Earth Parking Orbit

Apollo 13 was successfully launched on schedule from Launch Complex 39A, Kennedy Space Center, Florida, at 2:13 p.m. e.s.t., April 11, 1970. The launch vehicle stages inserted the S-IVB/instrument unit (IU)/spacecraft combination into an earth parking orbit with an apogee of 100.2 nautical miles (n. mi.) and a perigee of 98.0 n. mi. (100-n. mi. circular planned). During second stage boost, the center engine of the S-II stage cut off about 132 seconds early, causing the remaining four engines to burn approximately 34 seconds longer than predicted. Space vehicle velocity after S-II boost was 223 feet per second (fps) lower than planned. As a result, the S-IVB orbital insertion burn was approximately 9 seconds longer than predicted with cutoff velocity within about 1.2 fps of planned. Total launch vehicle burn time was about 44 seconds longer than predicted. A greater than 3-sigma probability of meeting translunar injection (TLI) cutoff conditions existed with remaining S-IVB propellants.

After orbital insertion, all launch vehicle and spacecraft systems were verified and preparation was made for translunar injection (TLI). Onboard television was initiated at 01:35 ground elapsed time (g.e.t.) for about 5.5 minutes. The second S-IVB burn was initiated on schedule for TLI. All major systems operated satisfactorily and all end conditions were nominal for a free-return circumlunar trajectory.

Translunar Coast

The CSM separated from the LM/IU/S-IVB at about 03:07 g.e.t. Onboard television was then initiated for about 72 minutes and clearly showed CSM "hard docking," ejection of the CSM/LM from the S-IVB at about 04:01 g.e.t., and the S-IVB auxiliary propulsion system (APS) evasive maneuver as well as spacecraft interior and exterior scenes. The SM RCS propellant usage for the separation, transposition, docking, and ejection was nominal. All launch vehicle safing activities were performed as scheduled.

The S-IVB APS evasive maneuver by an 8-second APS Ullage burn was initiated at 04:18 g.e.t. and was successfully completed. The liquid oxygen dump was initiated at 04:39 g.e.t. and was also successfully accomplished. The first S-IVB APS burn for lunar target point impact was initiated at 06:00 g.e.t. The burn duration was 217 seconds, producing a differential velocity of approximately 28 fps. Tracking information available at 08:00 g.e.t. indicated that the S-IVB/IU would impact at 6°53' S., 30°53' W. versus the targeted 3° S., 30° W. Therefore, the second S-IVB APS (trim) burn was not required. The gaseous nitrogen pressure dropped in the IU ST-124-M3 inertial platform at 18:25 g.e.t. and the S-IVB/IU no longer had attitude control but began tumbling slowly.

At approximately 19:17 g.e.t., a step input in tracking data indicated a velocity increase of approximately 4 to 5 fps. No conclusions have been reached on the reason for this increase. The velocity change altered the lunar impact point closer to the target. The S-IVB/IU impacted the lunar surface at 77:56:40 g.e.t. (08:09:40 p.m. e.s.t. April 14) at 2.4° S., 27.9° W., and the seismometer deployed during the Apollo 12 mission successfully detected the impact. The targeted impact point was 125 n. mi. from the seismometer. The actual impact point was 74 n. mi. from the seismometer, well within the desired 189-n. mi. (350-km) radius.

The accuracy of the TLI maneuver was such that spacecraft midcourse correction No. 1 (MCC-1), scheduled for 11:41 g.e.t., was not required. MCC-2 was performed as planned at 30:41 g.e.t. and resulted in placing the spacecraft on the desired, non-free-return circumlunar trajectory with a predicted closest approach to the moon on 62 n. mi. All SPS burn parameters were normal. The accuracy of MCC-3 was such that MCC-3, scheduled for 55:26 g.e.t., was not performed. Good quality television coverage of the preparations and performance of MCC-2 was received for 49 minutes beginning at 30:13 g.e.t.

At approximately 55:55 g.e.t. (10:08 p.m. e.s.t.), the crew reported an undervoltage alarm on the CSM main bus B. Pressure was rapidly lost in SM oxygen tank no. 2 and fuel cells 1 and 3 current dropped to zero due to loss of their oxygen supply. A decision was made to abort the mission. The increased load on fuel cell 2 and decaying pressure in the remaining oxygen tank led to the decision to activate the LM, power down the CSM, and use the LM systems for life support.

At 61:30 g.e.t., a 38-fps midcourse maneuver (MCC-4) was performed by the LM DPS to place the spacecraft in a free-return trajectory on which the CM would nominally land in the Indian Ocean south of Mauritius at approximately 152:00 g.e.t.

Transearch Coast

At pericyynthion plus 2 hours (79:28 g.e.t.), a LM DPS maneuver was performed to shorten the return trip time and move the earth landing point. The 263.4-second burn produced a differential velocity of 860.5 fps and resulted in an initial predicted earth landing point in the mid-Pacific Ocean at 142:53 g.e.t. Both LM guidance systems were powered up and the primary system was used for this maneuver. Following the maneuver, passive thermal control was established and the LM was powered down to conserve consumables; only the LM environmental control system (ECS) and communications and telemetry systems were kept powered up.

The LM DPS was used to perform MCC-5 at 105:19 g.e.t. The 15-second burn (at 10-percent throttle) produced a velocity change of about 7.8 fps

and successfully raised the entry flight path angle to -6.52° .

The CSM was partially powered up for a check of the thermal conditions of the CM with first reported receipt of S-band signal at 101:53 g.e.t. Thermal conditions on all CSM systems observed appeared to be in order for entry.

Due to the unusual spacecraft configuration, new procedures leading to entry were developed and verified in ground-based simulations. The resulting timeline called for a final midcourse correction (MCC-7) at entry interface (EI) -5 hours, jettison of the SM at EI -4.5 hours, then jettison of the LM at EI -1 hour prior to a normal atmospheric entry by the CM.

MCC-7 was successfully accomplished at 137:40 g.e.t. The 22.4-second LM RCS maneuver resulted in a predicted entry flight path angle of -6.49° . The SM was jettisoned at 138:02 g.e.t. The crew viewed and photographed the SM and reported that an entire panel was missing near the S-band high-gain antenna and a great deal of debris was hanging out. The CM was powered up and then the LM was jettisoned at 141:30 g.e.t. The EI at 40,000 feet was reached at 142:41 g.e.t.

Entry and Recovery

Weather in the prime recovery area was as follows: broken stratus clouds at 2000 feet; visibility 10 miles; 6-knot ENE winds; and wave height 1 to 2 feet. Drogue and main parachutes deployed normally. Visual contact with the spacecraft was reported at 142:50 g.e.t. Landing occurred at 142:54:41 g.e.t. (01:07:41 p.m. e.s.t., April 17). The landing point was in the mid-Pacific Ocean, approximately $21^{\circ}40'$ S., $165^{\circ}22'$ W. The CM landed in the stable 1 position about 3.5 n. mi. from the prime recovery ship, USS IWO JIMA. The crew, picked up by a recovery helicopter, was safe aboard the ship at 1:53 p.m. e.s.t., less than an hour after landing.

This page left blank intentionally.

CHAPTER 4

REVIEW AND ANALYSIS OF APOLLO 13 ACCIDENT

PART 1. INTRODUCTION

It became clear in the course of the Board's review that the accident during the Apollo 13 mission was initiated in the service module cryogenic oxygen tank no. 2. Therefore, the following analysis centers on that tank and its history. In addition, the recovery steps taken in the period beginning with the accident and continuing to reentry are discussed.

Two oxygen tanks essentially identical to oxygen tank no. 2 on Apollo 13, and two hydrogen tanks of similar design, operated satisfactorily on several unmanned Apollo flights and on the Apollo 7, 8, 9, 10, 11, and 12 manned missions. With this in mind, the Board placed particular emphasis on each difference in the history of oxygen tank no. 2 from the history of the earlier tanks, in addition to reviewing the design, assembly, and test history.

PART 2. OXYGEN TANK NO. 2 HISTORY

DESIGN

On February 26, 1966, the North American Aviation Corporation, now North American Rockwell (NR), prime contractor for the Apollo command and service modules (CSM), awarded a subcontract to the Beech Aircraft Corporation (Beech) to design, develop, fabricate, assemble, test, and deliver the Block II Apollo cryogenic gas storage subsystem. This was a follow-on to an earlier subcontract under which the somewhat different Block I subsystem was procured.

As the simplified drawing in figure 4-1 indicates, each oxygen tank has an outer shell and an inner shell, arranged to provide a vacuum space to reduce heat leak, and a dome enclosing paths into the tank for transmission of fluids and electrical power and signals. The space between the shells and the space in the dome are filled with insulating materials. Mounted in the tank are two tubular assemblies. One, called the heater tube, contains two thermostatically protected heater coils and two small fans driven by 1800 rpm motors to stir the tank contents. The other, called the quantity probe, consists of an upper section which supports a cylindrical capacitance gage used to measure electrically the quantity of fluid in the tank. The inner cylinder of this probe serves both as a fill and drain tube and as one plate of the capacitance gage. In addition, a temperature sensor is mounted on the outside of the quantity probe near the head. Wiring for the gage, the temperature sensor, the fan motors, and the heaters passes through the head of the quantity probe to a conduit in the dome. From there the wiring runs to a connector which ties it electrically to the appropriate external circuits in the CSM. The routing of wiring and lines from the tank through the dome is shown in figure 4-2.

As shown in figure 4-2, the fill line from the exterior of the SM enters the oxygen tank and connects to the inner cylinder of the capacitance gage through a coupling of two Teflon adapters or sleeves and a short length of Inconel tubing. The dimensions and tolerances selected are such that if "worst case" variations in an actual system were to occur, the coupling might not reach from the fill line to the gage cylinder (fig. 4-3). Thus, the variations might be such that a very loose fit would result.

The supply line from the tank leads from the head of the quantity probe to the dome and thence, after passing around the tank between the inner and outer shells, exits through the dome to supply oxygen to the fuel cells in the service module (SM) and the environmental control system (ECS) in the command module (CM). The supply line also connects

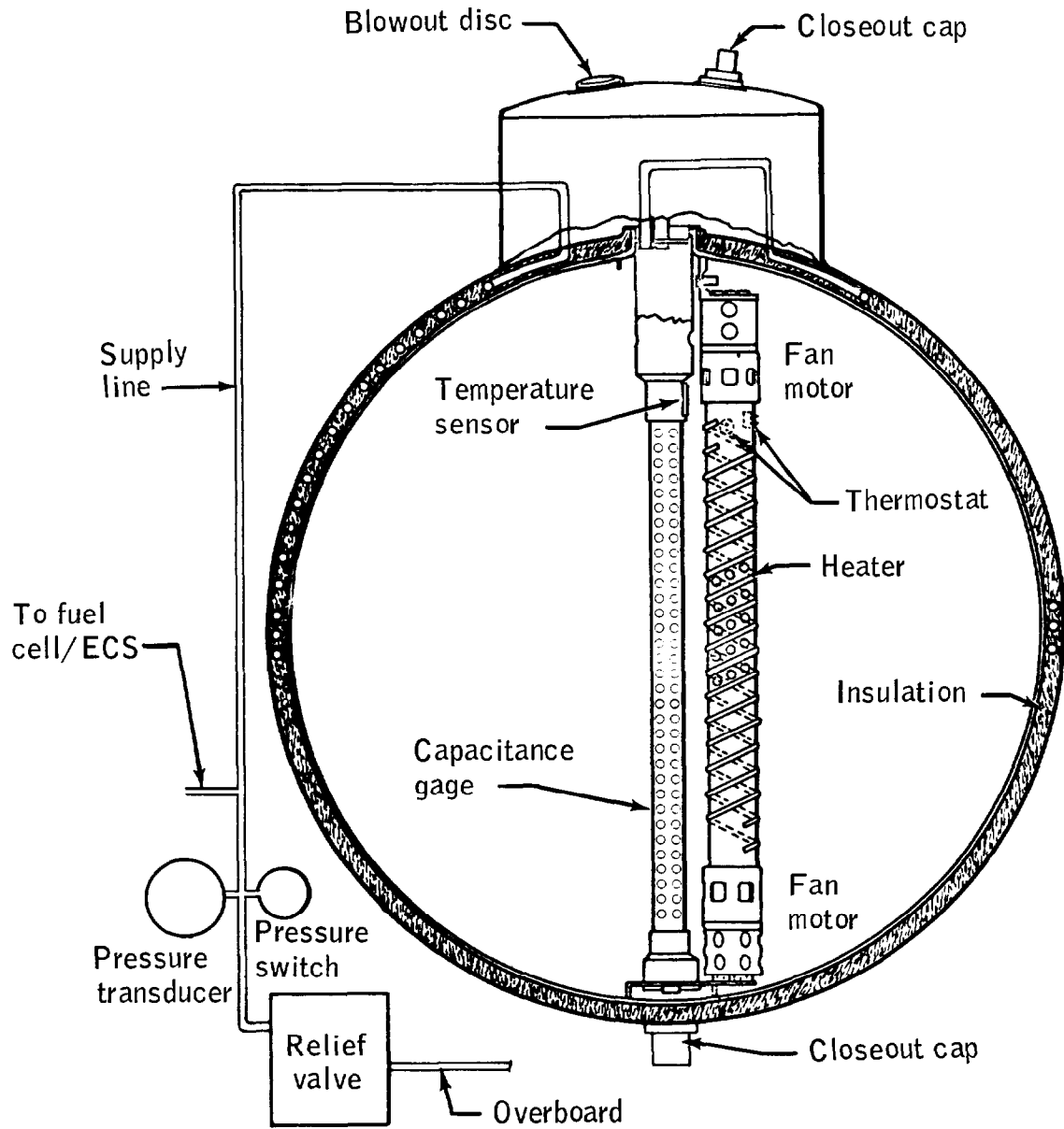

Figure 4-1.- Oxygen tank no. 2 internal components.

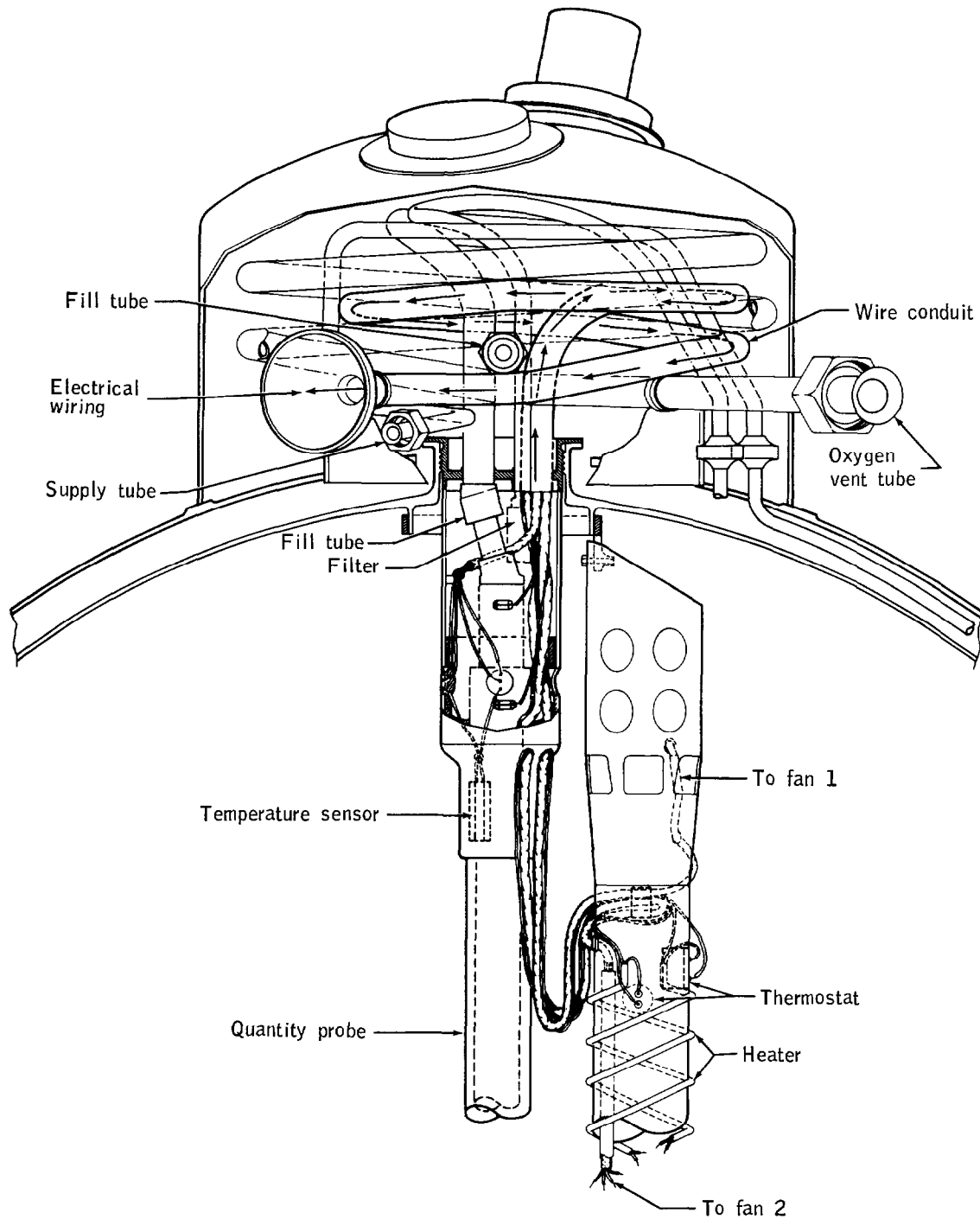

Figure 4-2.- Oxygen tank wiring and lines.

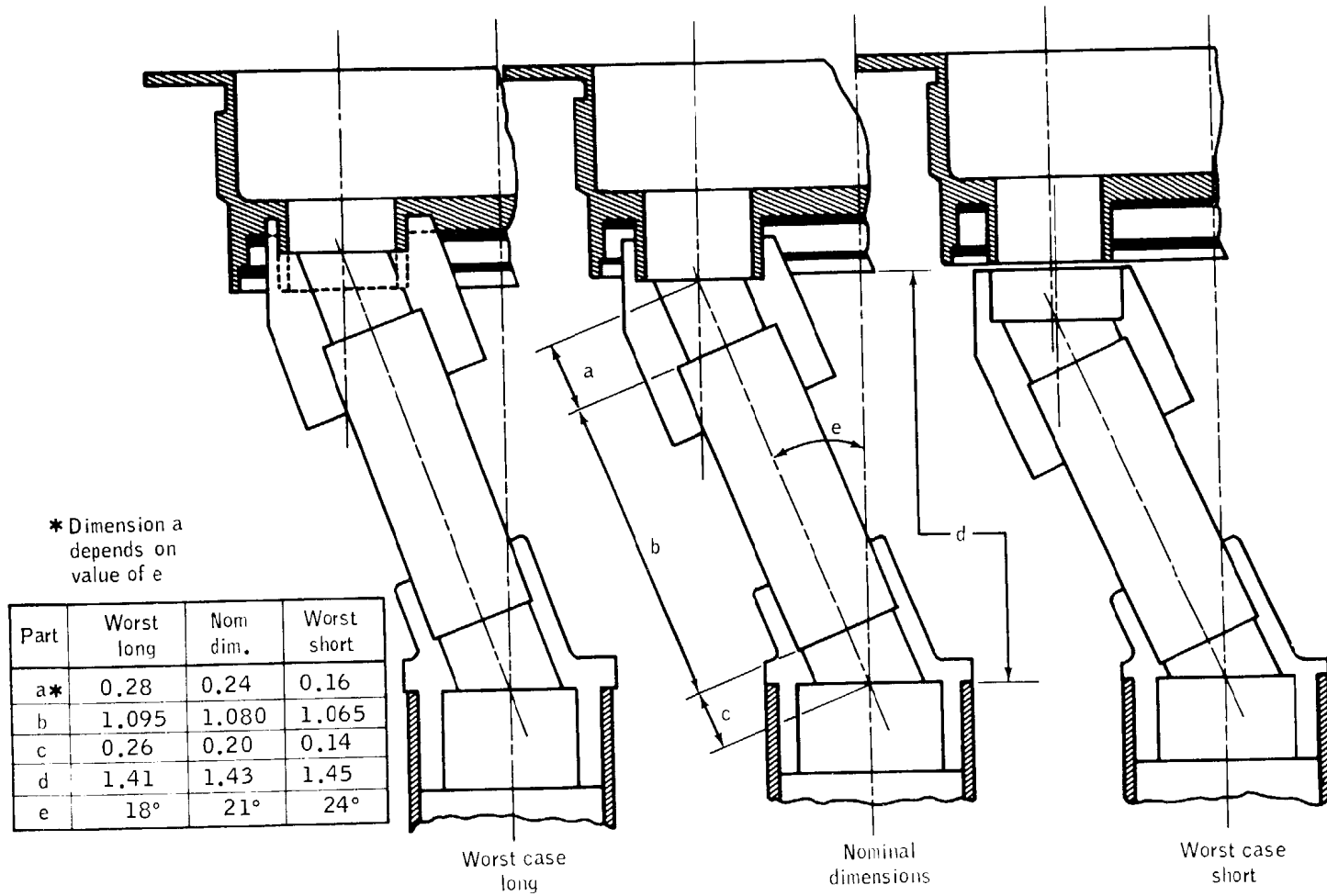

Figure 4-3.- Nominal and adverse tolerance cases.

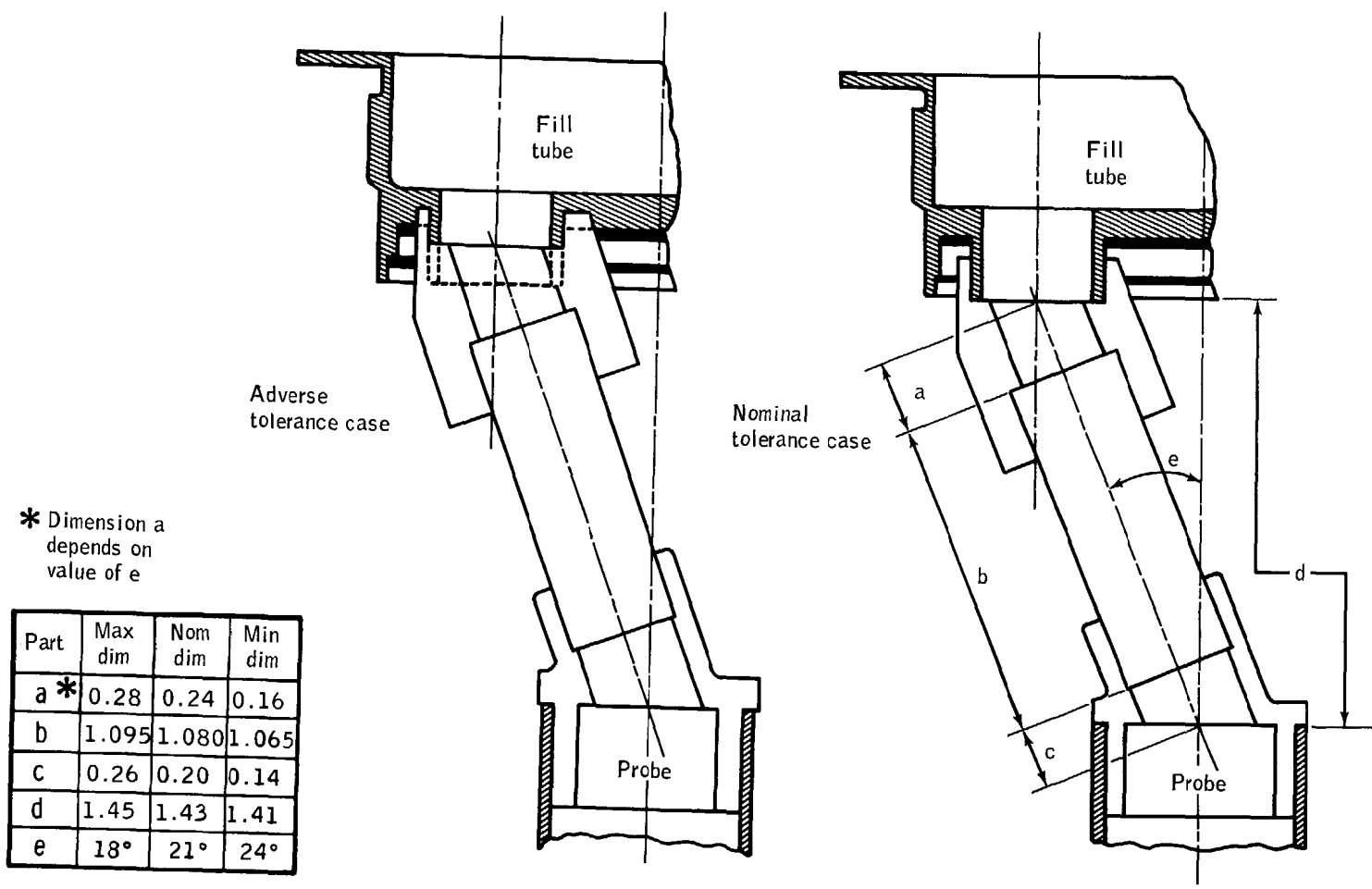

Figure 4-3.- Nominal and adverse tolerance cases.

to a relief valve. Under normal conditions, pressure in the tank is measured by a pressure gage in the supply line and a pressure switch near this gage is provided to turn on the heaters in the oxygen tank if the pressure drops below a preselected value. This periodic addition of heat to the tank maintains the pressure at a sufficient level to satisfy the demand for oxygen as tank quantity decreases during a flight mission.

The oxygen tank is designed for a capacity of 320 pounds of supercritical oxygen at pressures ranging between 865 to 935 pounds per square inch absolute (psia). The tank is initially filled with liquid oxygen at -297° F and operates over the range from -340° F to $+80^{\circ}$ F. The term "supercritical" means that the oxygen is maintained at a temperature and pressure which assures that it is a homogeneous, single-phase fluid.

The burst pressure of the oxygen tank is about 2200 psi at -150° F, over twice the normal operating pressure at that temperature. The relief valve is designed to relieve pressure in the oxygen tank overboard at a pressure of approximately 1000 psi. The oxygen tank dome is open to the vacuum between the inner and outer tank shell and contains a rupture disc designed to blow out at about 75 psi.

The approximate amounts of principal materials within the oxygen tank are set forth in table 4-I.

TABLE 4-I.- MATERIALS WITHIN OXYGEN TANK

Material	Approximate quantity, lb	Available energy, Btu
Teflon-wire insulation sleeving and solid	1.1	2,400
Aluminum (all forms)	0.8	20,500
Stainless steel	2.4	15,000
Inconel alloys	1.7	2,900

Two oxygen tanks are mounted on a shelf in bay 4 of the SM, as shown in figure 4-4. Figures 4-5 through 4-8 are photographs of portions

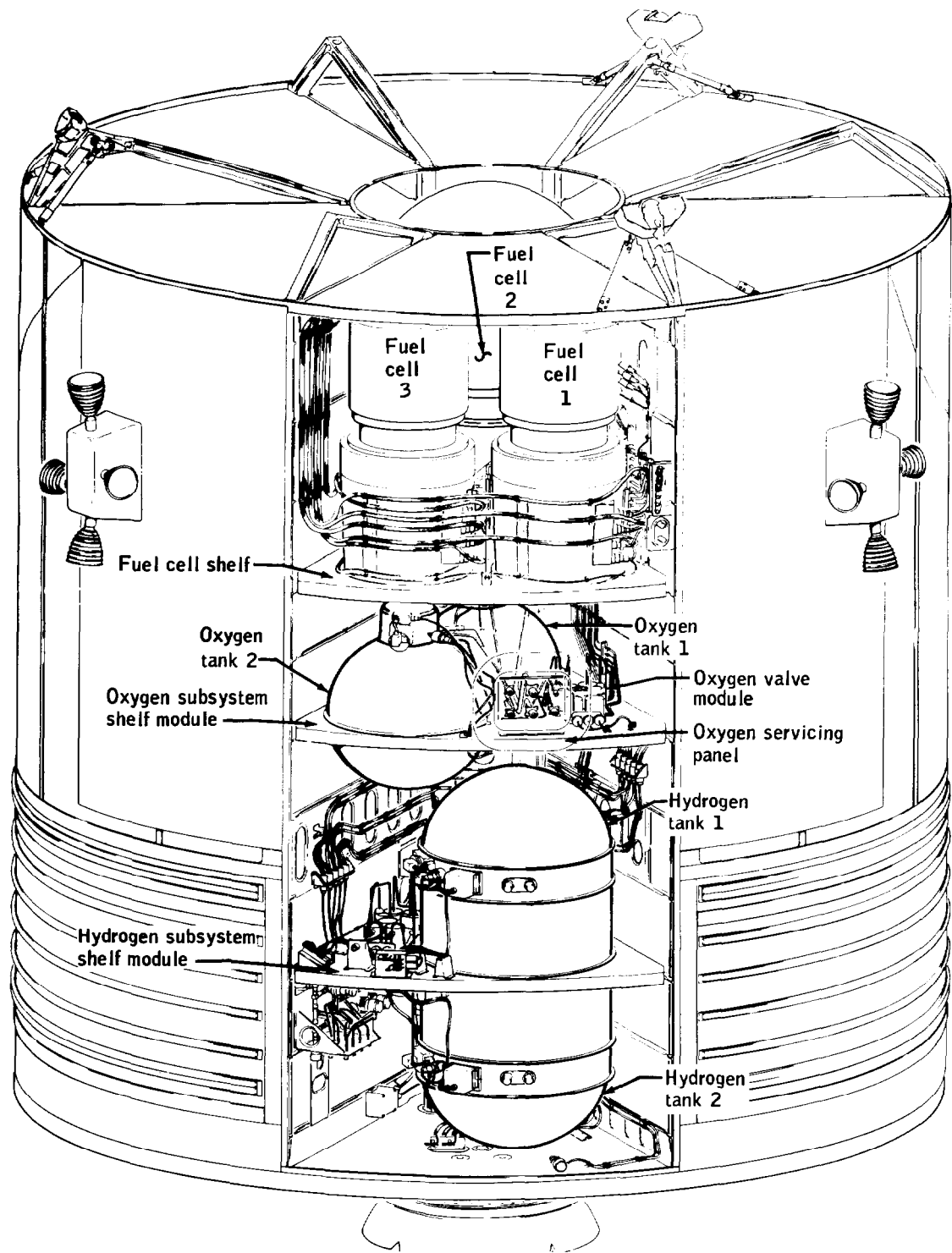

Figure 4-4.- Arrangement of fuel cells and cryogenic systems in bay 4.

This page left blank intentionally.

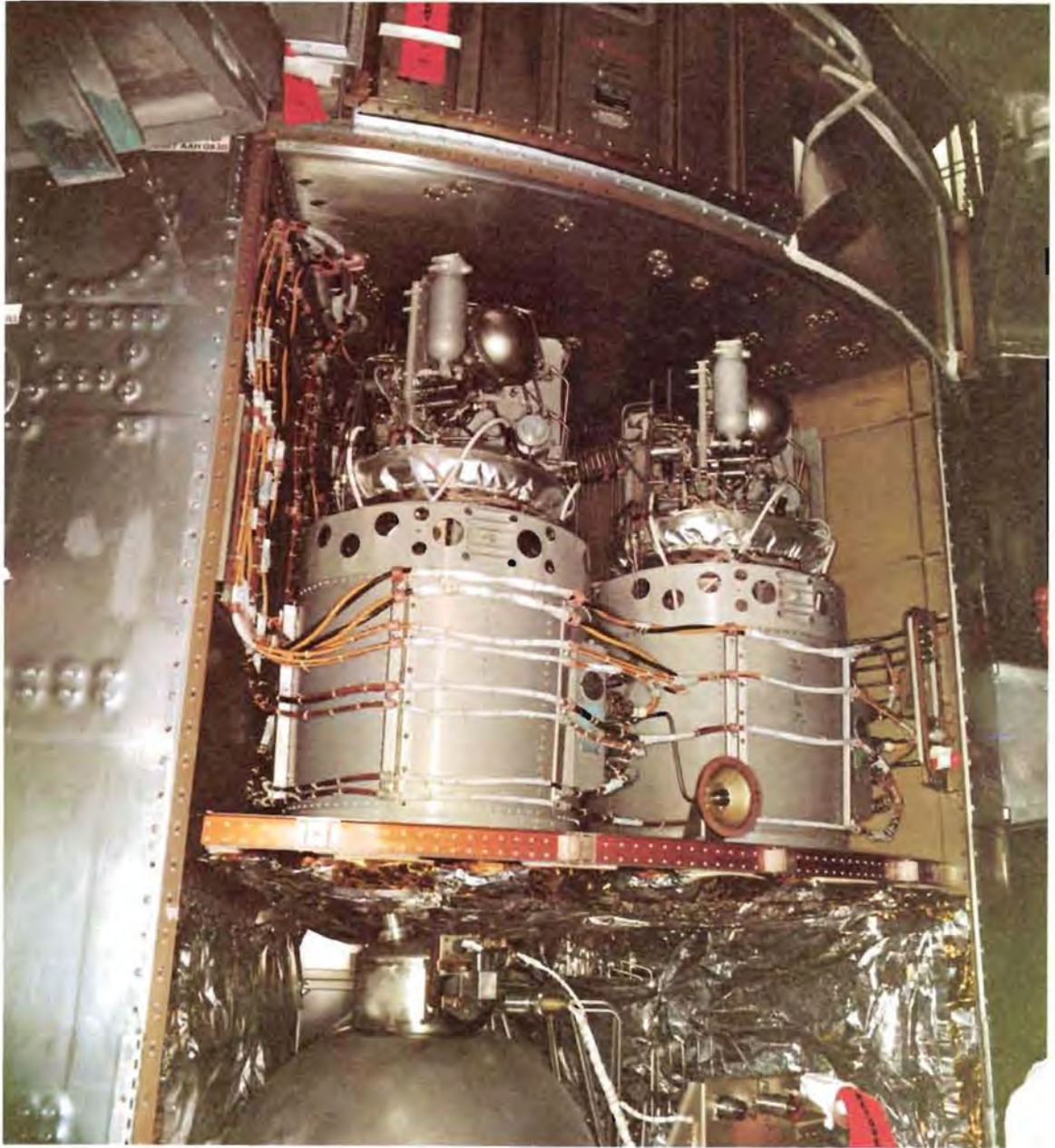
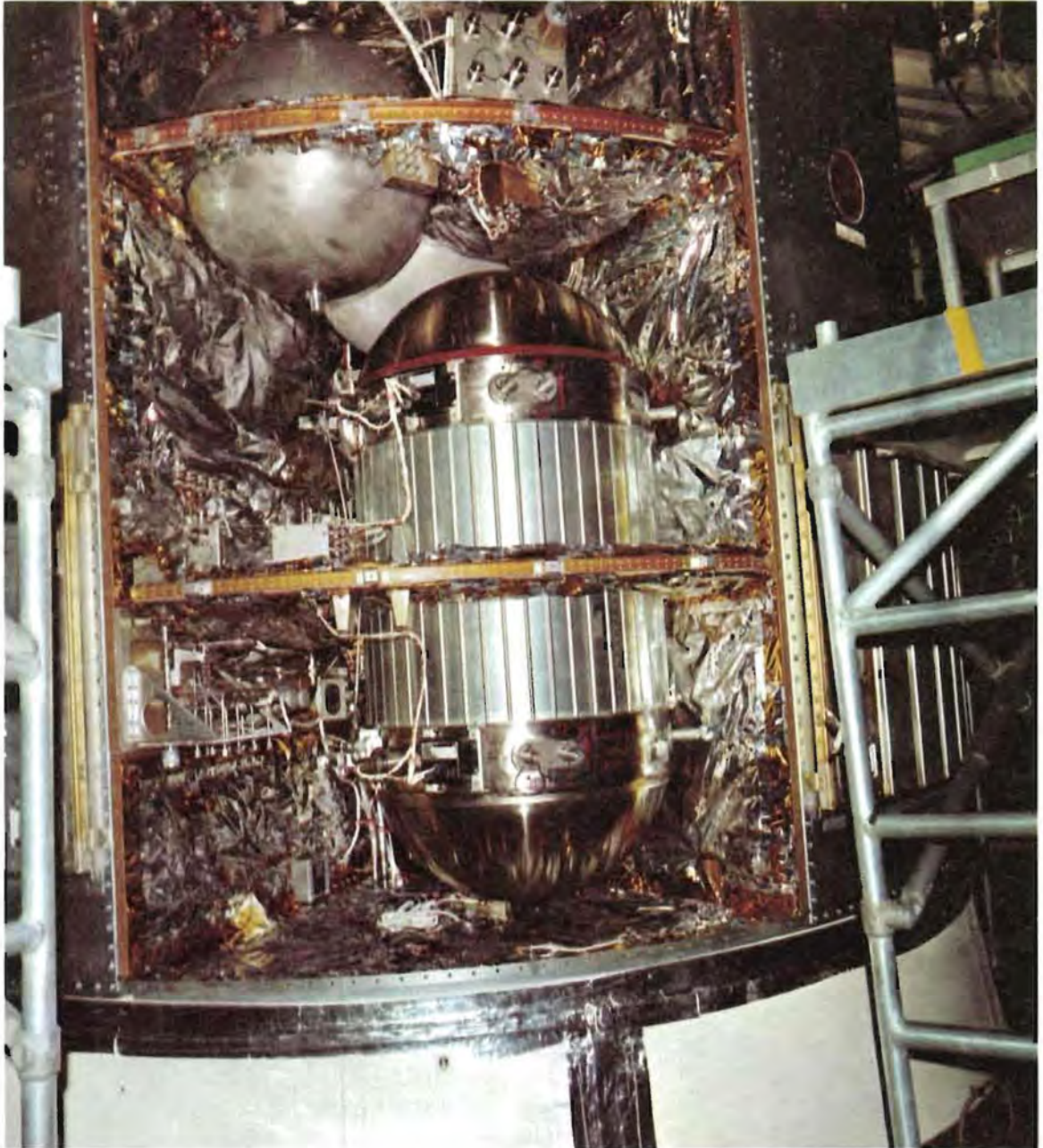

Figure 4-5.- Fuel cells shelf.



Figure 4-6.- Oxygen tank shelf.



4-7.-
Figure ~~X-X-X~~ Hydrogen tank shelf.

4-13/4-14



4-8.-
Figure ~~XXX~~ Inside view of panel covering bay 4.



of the Apollo 13 service module (SM 109) at the North American Rockwell plant prior to shipment to KSC. Figure 4-5 shows the fuel cell shelf, with fuel cell 1 on the right, fuel cell 3 on the left, and fuel cell 2 behind cells 1 and 3. The top of oxygen tank no. 2 can be seen at the lower left. Figure 4-6 shows the oxygen tank shelf, with oxygen tank no. 2 at left center. Figure 4-7 shows the hydrogen tank shelf with hydrogen tank no. 1 on top and hydrogen tank no. 2 below. The bottom of the oxygen shelf shows some of the oxygen system instrumentation and wiring, largely covered by insulation. Figure 4-8 is a photograph of the bay 4 panel, which was missing from the service module after the accident.

A more detailed description of the oxygen tank design is contained in Appendix D to this report.

MANUFACTURE

The manufacture of oxygen tank no. 2 began in 1966. Under subcontracts with Beech, the inner shell of the tank was manufactured by the Airite Products Division of Electrada Corporation; the quantity probe was made by Simmonds Precision Products, Inc.; and the fans and fan motors were produced by Globe Industries, Inc.

The Beech serial number assigned to the oxygen tank no. 2 flown in the Apollo 13 was 10024XTA0008. It was the eighth Block II oxygen tank built. Twenty-eight Block I oxygen tanks had previously been built by Beech.

The design of the oxygen tank is such that once the upper and lower halves of the inner and outer shells are assembled and welded, the heater assembly must be inserted in the tank, moved to one side, and bolted in place. Then the quantity probe is inserted into the tank and the heater assembly wires (to the heaters, the thermostats, and the fan motors) must be pulled through the head of the quantity probe and the 32-inch coiled conduit in the dome. Thus, the design requires during assembly a substantial amount of wire movement inside the tank, where movement cannot be readily observed, and where possible damage to wire insulation by scraping or flexing cannot be easily detected before the tank is capped off and welded closed.

Several minor manufacturing flaws were discovered in oxygen tank no. 2 in the course of testing. A porosity in a weld on the lower half of the outer shell necessitated grinding and rewelding. Rewelding was also required when it was determined that incorrect welding wire had been inadvertently used for a small weld on a vacuum pump mounted on

the outside of the tank dome. The upper fan motor originally installed was noisy and drew excessive current. The tank was disassembled and the heater assembly, fans, and heaters were replaced with a new assembly and new fans. The tank was then assembled and sealed for the second time, and the space between the inner and outer shells was pumped down over a 28-day period to create the necessary vacuum.

TANK TESTS AT BEECH

Acceptance testing of oxygen tank no. 2 at Beech included extensive dielectric, insulation, and functional tests of heaters, fans, and vacuum pumps. The tank was then leak tested at 500 psi and proof tested at 1335 psi with helium.

After the helium proof test, the tank was filled with liquid oxygen and pressurized to a proof pressure of 1335 psi by use of the tank heaters powered by 65 V ac. Extensive heat-leak tests were run at 900 psi for 25 to 30 hours over a range of ambient conditions and out-flow rates. At the conclusion of the heat-leak tests, about 100 pounds of oxygen remained in the tank. About three-fourths of this was released by venting the tank at a controlled rate through the supply line to about 20 psi. The tank was then emptied by applying warm gas at about 30 psi to the vent line to force the liquid oxygen (LOX) in the tank out the fill line (see fig. 4-2). No difficulties were recorded in this detanking operation.

The acceptance test indicated that the rate of heat leak into the tank was higher than permitted by the specifications. After some reworking, the rate improved, but was still somewhat higher than specified. The tank was accepted with a formal waiver of this condition. Several other minor discrepancies were also accepted. These included oversized holes in the support for the electrical plug in the tank dome, and an oversized rivet hole in the heater assembly just above the lower fan. None of these items were serious, and the tank was accepted, filled with helium at 5 psi, and shipped to NR on May 3, 1967.

ASSEMBLY AND TEST AT NORTH AMERICAN ROCKWELL

The assembly of oxygen shelf serial number 0632AAG3277, with Beech oxygen tank serial number 10024XTA0009 as oxygen tank no. 1 and serial number 10024XTA0008 as oxygen tank no. 2, was completed on March 11, 1968. The shelf was to be installed in SM 106 for flight in the Apollo 10 mission.

Beginning on April 27, the assembled oxygen shelf underwent standard proof-pressure, leak, and functional checks. One valve on the shelf leaked and was repaired, but no anomalies were noted with regard to oxygen tank no. 2, and therefore no rework of oxygen tank no. 2 was required. None of the oxygen tank testing at NR requires use of LOX in the tanks.

On June 4, 1968, the shelf was installed in SM 106.

Between August 3 and August 8, 1968, testing of the shelf in the SM was conducted. No anomalies were noted.

Due to electromagnetic interference problems with the vac-ion pumps on cryogenic tank domes in earlier Apollo spacecraft, a modification was introduced and a decision was made to replace the complete oxygen shelf in SM 106. An oxygen shelf with approved modifications was prepared for installation in SM 106. On October 21, 1968, the oxygen shelf was removed from SM 106 for the required modification and installation in a later spacecraft.

The oxygen shelf was removed in the manner shown in figure 4-9. After various lines and wires were disconnected and bolts which hold the shelf in the SM were removed, a fixture suspended from a crane was placed under the shelf and used to lift the shelf and extract it from bay 4. One shelf bolt was mistakenly left in place during the initial attempt to remove the shelf; and as a consequence, after the front of the shelf was raised about 2 inches, the fixture broke, allowing the shelf to drop back into place. Photographs of the underside of the fuel cell shelf in SM 106 indicate that the closeout cap on the dome of oxygen tank no. 2 may have struck the underside of that shelf during this incident. At the time, however, it was believed that the oxygen shelf had simply dropped back into place and an analysis was performed to calculate the forces resulting from a drop of 2 inches. It now seems likely that the shelf was first accelerated upward and then dropped.

The remaining bolt was then removed, the incident recorded, and the oxygen shelf was removed without further difficulty. Following removal, the oxygen shelf was retested to check shelf integrity, including proof-pressure tests, leak tests, and functional tests of pressure transducers and switches, thermal switches, and vac-ion pumps. No cryogenic testing was conducted. Visual inspection revealed no problem. These tests would have disclosed external leakage or serious internal malfunctions of most types, but would not disclose fill line leakage within oxygen tank no. 2. Further calculations and tests conducted during this investigation, however, have indicated that the forces experienced by the shelf were probably close to those originally

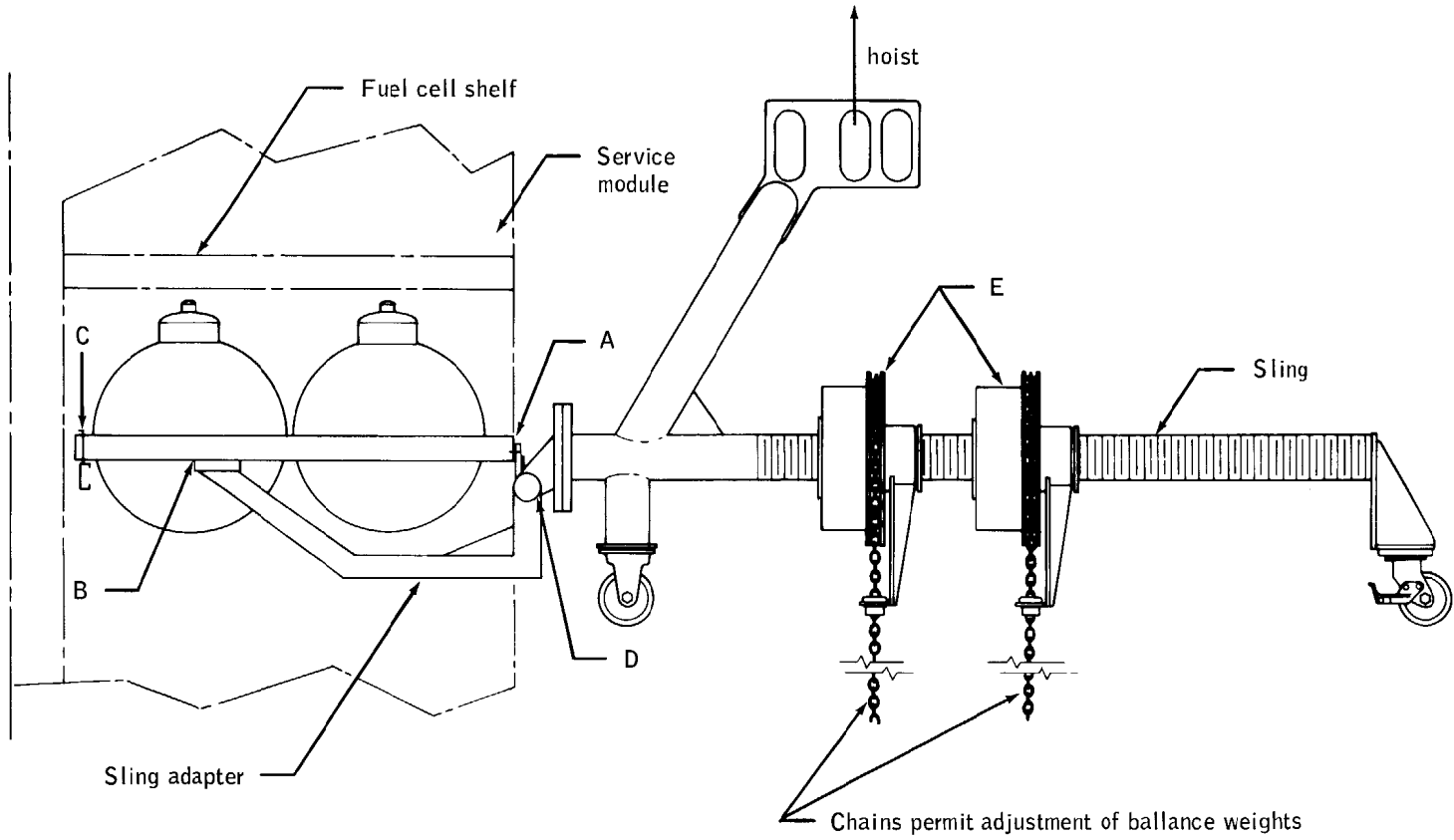

Figure 4-9.- Hoist and sling arrangement - oxygen shelf.

calculated assuming a 2-inch drop only. The probability of tank damage from this incident, therefore, is now considered to be rather low, although it is possible that a loosely fitting fill tube could have been displaced by the event.

The shelf passed these tests and was installed in SM 109 on November 22, 1968. The shelf tests accomplished earlier in SM 106 were repeated in SM 109 in late December and early January, with no significant problems, and SM 109 was shipped to Kennedy Space Center (KSC) in June of 1969 for further testing, assembly on the launch vehicle, and launch.

TESTING AT KSC

At the Kennedy Space Center the CM and the SM were mated, checked, assembled on the Saturn V launch vehicle, and the total vehicle was moved to the launch pad.

The countdown demonstration test (CDDT) began on March 16, 1970. Up to this point, nothing unusual about oxygen tank no. 2 had been noted during the extensive testing at KSC. The oxygen tanks were evacuated to 5mm Hg followed by an oxygen pressure of about 80 psi. After the cooling of the fuel cells, cryogenic oxygen loading and tank pressurization to 331 psi were completed without abnormalities. At the time during CDDT when the oxygen tanks are normally partially emptied to about 50 percent of capacity, oxygen tank no. 1 behaved normally, but oxygen tank no. 2 only went down to 92 percent of its capacity. The normal procedure during CDDT to reduce the quantity in the tank is to apply gaseous oxygen at 80 psi through the vent line and to open the fill line. When this procedure failed, it was decided to proceed with the CDDT until completion and then look at the oxygen detanking problem in detail. An Interim Discrepancy Report was written and transferred to a Ground Support Equipment (GSE) Discrepancy Report, since a GSE filter was suspected.

On Friday, March 27, 1970, detanking operations were resumed, after discussions of the problem had been held with KSC, MSC, NR, and Beech personnel participating, either personally or by telephone. As a first step, oxygen tank no. 2, which had self-pressurized to 178 psi and was about 83 percent full, was vented through its fill line. The quantity decreased to 65 percent. Further discussions between KSC, MSC, NR, and Beech personnel considered that the problem might be due to a leak in the path between the fill line and the quantity probe due to loose fit in the sleeves and tube. Referring to figure 4-2, it will be noted that such a leak would allow the gaseous oxygen (GOX) being supplied to the vent line to leak directly to the fill line without forcing any

significant amount of LOX out of the tank. At this point, a discrepancy report against the spacecraft system was written.

A "normal" detanking procedure was then conducted on both oxygen tanks, pressurizing through the vent line and opening the fill lines. Tank no. 1 emptied in a few minutes. Tank no. 2 did not. Additional attempts were made with higher pressures without effect, and a decision was made to try to "boil off" the remaining oxygen in tank no. 2 by use of the tank heaters. The heaters were energized with the 65 V dc. GSE power supply, and, about 1-1/2 hours later, the fans were turned on to add more heat and mixing. After 6 hours of heater operation, the quantity had only decreased to 35 percent, and it was decided to attempt a pressure cycling technique. With the heaters and fans still energized, the tank was pressurized to about 300 psi, held for a few minutes, and then vented through the fill line. The first cycle produced a 7-percent quantity decrease, and the process was continued, with the tank emptied after five pressure/vent cycles. The fans and heaters were turned off after about 8 hours of heater operation.

Suspecting the loosely fitting fill line connection to the quantity probe inner cylinder, KSC personnel consulted with cognizant personnel at MSC and at NR and decided to test whether the oxygen tank no. 2 could be filled without problems. It was decided that if the tank could be filled, the leak in the fill line would not be a problem in flight, since it was felt that even a loose tube resulting in an electrical short between the capacitance plates of the quantity gage would result in an energy level too low to cause any other damage.

Replacement of the oxygen shelf in the CM would have been difficult and would have taken at least 45 hours. In addition, shelf replacement would have had the potential of damaging or degrading other elements of the SM in the course of replacement activity. Therefore, the decision was made to test the ability to fill oxygen tank no. 2 on March 30, 1970, twelve days prior to the scheduled Saturday, April 11, launch, so as to be in a position to decide on shelf replacement well before the launch date.

Accordingly, flow tests with GOX were run on oxygen tank no. 2 and on oxygen tank no. 1 for comparison. No problems were encountered, and the flow rates in the two tanks were similar. In addition, Beech was asked to test the electrical energy level reached in the event of a short circuit between plates of the quantity probe capacitance gage. This test showed that very low energy levels would result. On the filling test, oxygen tanks no. 1 and no. 2 were filled with LOX to about 20 percent of capacity on March 30 with no difficulty. Tank no. 1 emptied in the normal manner, but emptying oxygen tank no. 2 again required pressure cycling with the heaters turned on.

As the launch date approached, the oxygen tank no. 2 detanking problem was considered by the Apollo organization. At this point, the "shelf drop" incident on October 21, 1968, at NR was not considered and it was felt that the apparently normal detanking which had occurred in 1967 at Beech was not pertinent because it was believed that a different procedure was used by Beech. In fact, however, the last portion of the procedure was quite similar, although a slightly lower GOX pressure was utilized.

Throughout these considerations, which involved technical and management personnel of KSC, MSC, NR, Beech, and NASA Headquarters, emphasis was directed toward the possibility and consequences of a loose fill tube; very little attention was paid to the extended operation of heaters and fans except to note that they apparently operated during and after the detanking sequences.

Many of the principals in the discussions were not aware of the extended heater operations. Those that did know the details of the procedure did not consider the possibility of damage due to excessive heat within the tank, and therefore did not advise management officials of any possible consequences of the unusually long heater operations.

As noted earlier in this chapter, and shown in figure 4-2, each heater is protected with a thermostatic switch, mounted on the heater tube, which is intended to open the heater circuit when it senses a temperature of 80° F. In tests conducted at MSC since the accident, however, it was found that the switches failed to open when the heaters were powered from a 65 V dc supply similar to the power used at KSC during the detanking sequence. Subsequent investigations have shown that the thermostatic switches used, while rated as satisfactory for the 28 V dc spacecraft power supply, could not open properly at 65 V dc. Qualification and test procedures for the heater assemblies and switches do not at any time test the capability of the switches to open while under full current conditions. A review of the voltage recordings made during the detanking at KSC indicates that, in fact, the switches did not open when the temperature indication from within the tank rose past 80° F. Further tests have shown that the temperatures on the heater tube may have reached as much as 1000° F during the detanking. This temperature will cause serious damage to adjacent Teflon insulation, and such damage almost certainly occurred.

None of the above, however, was known at the time and, after extensive consideration was given to all possibilities of damage from a loose fill tube, it was decided to leave the oxygen shelf and oxygen tank no. 2 in the SM and to proceed with preparations for the launch of Apollo 13.

The manufacture and test history of oxygen tank no. 2 is discussed in more detail in Appendix C to this report.

PART 3. THE APOLLO 13 FLIGHT

The Apollo 13 mission was designed to perform the third manned lunar landing. The selected site was in the hilly uplands of the Fra Mauro formation. A package of five scientific experiments was planned for emplacement on the lunar surface near the lunar module (LM) landing point: (1) a lunar passive seismometer to measure and relay meteoroid impact and moonquakes and to serve as the second point in a seismic net begun with the Apollo 12 seismometer; (2) a heat flow device for measuring the heat flux from the lunar interior to the surface and surface material conductivity to a depth of 3 meters; (3) a charged-particle lunar environment experiment for measuring solar wind proton and electron effects on the lunar environment; (4) a cold cathode gage for measuring density and temperature variations in the lunar atmosphere; and (5) a dust detector experiment.

Additionally, the Apollo 13 landing crew was to gather the third set of selenological samples of the lunar surface for return to earth for extensive scientific analysis. Candidate future landing sites were scheduled to be photographed from lunar orbit with a high-resolution topographic camera carried aboard the command module.

During the week prior to launch, backup Lunar Module Pilot Charles M. Duke, Jr., contracted rubella. Blood tests were performed to determine prime crew immunity, since Duke had been in close contact with the prime crew. These tests determined that prime Commander James A. Lovell and prime Lunar Module Pilot Fred Haise were immune to rubella, but that prime Command Module Pilot Thomas K. Mattingly III did not have immunity. Consequently, following 2 days of intensive simulator training at the Kennedy Space Center, backup Command Module Pilot John L. Swigert, Jr., was substituted in the prime crew to replace Mattingly. Swigert had trained for several months with the backup crew, and this additional work in the simulators was aimed toward integrating him into the prime crew so that the new combination of crewmen could function as a team during the mission.

Launch was on time at 2:13 p.m., e.s.t., on April 11, 1970, from the KSC Launch Complex 39A. The spacecraft was inserted into a 100-nautical-mile circular earth orbit. The only significant launch phase anomaly was premature shutdown of the center engine of the S-II second stage. As a result, the remaining four S-II engines burned 34 seconds longer than planned and the S-IVB third stage burned a few seconds longer than planned. At orbital insertion, the velocity was within 1.2 feet per second of the planned velocity. Moreover, an adequate propellant margin was maintained in the S-IVB for the translunar injection burn.

Orbital insertion was at 00:12:39 ground elapsed time (g.e.t.). The initial one and one-half earth orbits before translunar injection (TLI) were spent in spacecraft systems checkout and included television transmissions as Apollo 13 passed over the Merritt Island Launch Area, Florida, tracking station.

The S-IVB restarted at 02:35:46 g.e.t. for the translunar injection burn, with shutdown coming some 5 minutes 51 seconds later. Accuracy of the Saturn V instrument unit guidance for the TLI burn was such that a planned midcourse correction maneuver at 11:41:23 g.e.t. was not necessary. After TLI, Apollo 13 was calculated to be on a free-return trajectory with a predicted closest approach to the lunar surface of 210 nautical miles.

The CSM was separated from the S-IVB about 3 hours after launch, and after a brief period of stationkeeping, the crew maneuvered the CSM to dock with the LM vehicle in the LM adapter atop the S-IVB stage. The S-IVB stage was separated from the docked CSM and LM shortly after 4 hours into the mission.

In manned lunar missions prior to Apollo 13, the spent S-IVB third stages were accelerated into solar orbit by a "slingshot" maneuver in which residual liquid oxygen was dumped through the J-2 engine to provide propulsive energy. On Apollo 13, the plan was to impact the S-IVB stage on the lunar surface in proximity to the seismometer emplaced in the Ocean of Storms by the crew of Apollo 12.

Two hours after TLI, the S-IVB attitude thrusters were ground commanded on to adjust the stage's trajectory toward the designated impact at latitude 3° S. by longitude 30° W. Actual impact was at latitude 2.4° S. by longitude 27.9° W.--74 nautical miles from the Apollo 12 seismometer and well within the desired range. Impact was at 77:56:40 g.e.t. Seismic signals relayed by the Apollo 12 seismometer as the 30,700-pound stage hit the Moon lasted almost 4 hours and provided lunar scientists with additional data on the structure of the Moon.

As in previous lunar missions, the Apollo 13 spacecraft was set up in the passive thermal control (PTC) mode which calls for a continuous roll rate of three longitudinal axis revolutions each hour. During crew rest periods and at other times in translunar and transearth coast when a stable attitude is not required, the spacecraft is placed in PTC to stabilize the thermal response by spacecraft structures and systems.

At 30:40:49 g.e.t., a midcourse correction maneuver was made using the service module propulsion system. The crew preparations for the burn and the burn itself were monitored by the Mission Control Center (MMC) at MSC by telemetered data and by television from the spacecraft. This midcourse correction maneuver was a 23.2 feet per second hybrid

transfer burn which took Apollo 13 off a free-return trajectory and placed it on a non-free-return trajectory. A similar trajectory had been flown on Apollo 12. The objective of leaving a free-return trajectory is to control the arrival time at the Moon to insure the proper lighting conditions at the landing site. Apollo 8, 10, and 11 flew a pure free-return trajectory until lunar orbit insertion. The Apollo 13 hybrid transfer maneuver lowered the predicted closest approach, or pericyynthion, altitude at the Moon from 210 to 64 nautical miles.

From launch through the first 46 hours of the mission, the performance of oxygen tank no. 2 was normal, so far as telemetered data and crew observations indicate. At 46:40:02, the crew turned on the fans in oxygen tank no. 2 as a routine operation. Within 3 seconds, the oxygen tank no. 2 quantity indication changed from a normal reading of about 82 percent full to an obviously incorrect reading "off-scale high," of over 100 percent. Analysis of the electrical wiring of the quantity gage shows that this erroneous reading could be caused by either a short circuit or an open circuit in the gage wiring or a short circuit between the gage plates. Subsequent events indicated that a short was the more likely failure mode.

At 47:54:50 and at 51:07:44, the oxygen tank no. 2 fans were turned on again, with no apparent adverse effects. The quantity gage continued to read off-scale high.

Following a rest period, the Apollo 13 crew began preparations for activating and powering up the LM for checkout. At 53:27 g.e.t., the Commander (CMR) and Lunar Module Pilot (LMP) were cleared to enter the LM to commence inflight inspection of the LM. Ground tests before launch had indicated the possibility of a high heat-leak rate in the LM descent stage supercritical helium tank. Crew verification of actual pressures found the helium pressure to be within normal limits. Supercritical helium is stored in the LM for pressurizing propellant tanks.

The LM was powered down and preparations were underway to close the LM hatch and run through the presleep checklist when the accident in oxygen tank no. 2 occurred.

At 55:52:30 g.e.t., a master alarm on the CM caution and warning system alerted the crew to a low pressure indication in the cryogenic hydrogen tank no. 1. This tank had reached the low end of its normal operating pressure range several times previously during the flight. At 55:52:58, flight controllers in the MCC requested the crew to turn on the cryogenic system fans and heaters.

The Command Module Pilot (CMP) acknowledged the fan cycle request at 55:53:06 g.e.t., and data indicate that current was applied to the oxygen tank no. 2 fan motors at 55:53:20.

About 1-1/2 minutes later, at 55:54:53.555, telemetry from the spacecraft was lost almost totally for 1.8 seconds. During the period of data loss, the caution and warning system alerted the crew to a low voltage condition on dc main bus B. At about the same time, the crew heard a loud "bang" and realized that a problem existed in the spacecraft.

The events between fan turnon at 55:53:20 and the time when the problem was evident to the crew and Mission Control are covered in some detail in Part 4 of this chapter, "Summary Analysis of the Accident." It is now clear that oxygen tank no. 2 or its associated tubing lost pressure integrity because of combustion within the tank, and that effects of oxygen escaping from the tank caused the removal of the panel covering bay 4 and a relatively slow leak in oxygen tank no. 1 or its lines or valves. Photos of the SM taken by the crew later in the mission show the panel missing, the fuel cells on the shelf above the oxygen shelf tilted, and the high-gain antenna damaged.

The resultant loss of oxygen made the fuel cells inoperative, leaving the CM with batteries normally used only during reentry as the sole power source and with only that oxygen contained in a surge tank and repressurization packages (used to repressurize the CM after cabin venting). The LM, therefore, became the only source of sufficient electrical power and oxygen to permit safe return of the crew to Earth.

The various telemetered parameters of primary interest are shown in figure 4-10 and listed in table 4-11.

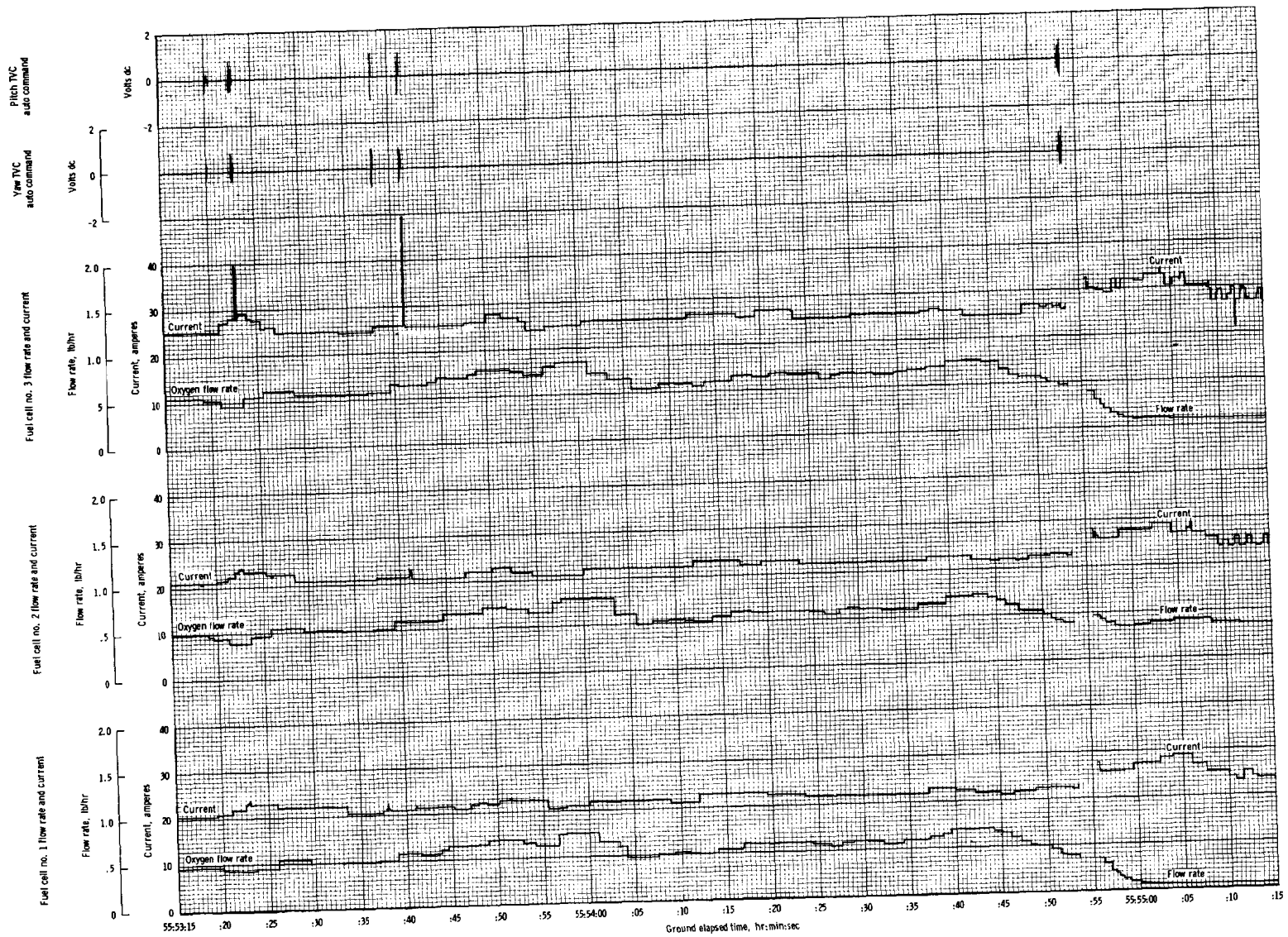

Figure 4-10.- Telemetry record.

4-30

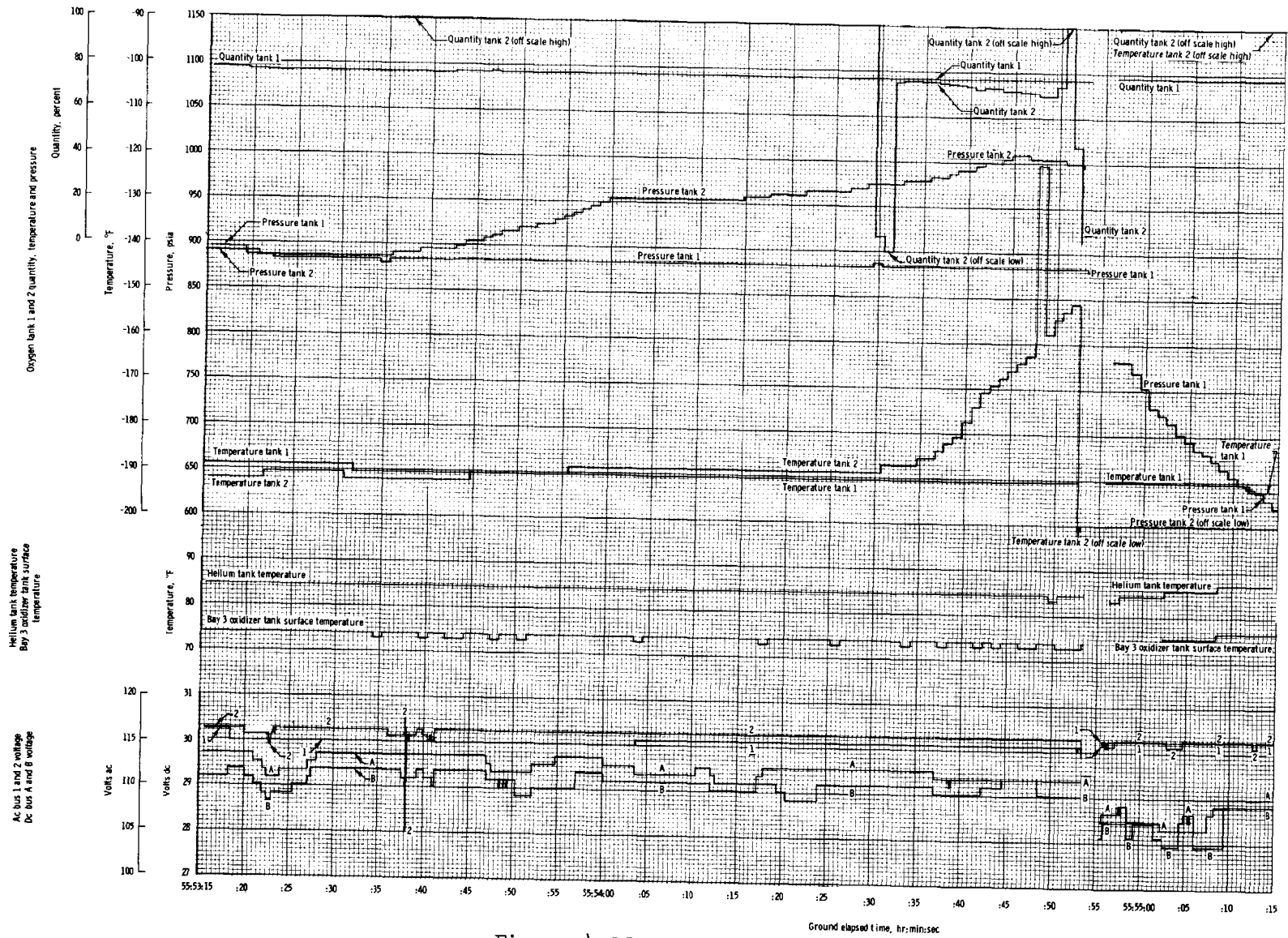

Figure 4-10.- Concluded.

TABLE 4-II.- DETAILED CHRONOLOGY FROM
2.5 MINUTES BEFORE THE ACCIDENT TO 5 MINUTES AFTER THE ACCIDENT

<u>Time, g.e.t.</u>	<u>Event</u>
Events During 52 Seconds Prior to First Observed Abnormality	
55:52:31	Master caution and warning triggered by low hydrogen pressure in tank no. 1. Alarm is turned off after 4 seconds.
55:52:58	Ground requests tank stir.
55:53:06	Crew acknowledges tank stir.
55:53:18	Oxygen tank no. 1 fans on.
55:53:19	Oxygen tank no. 1 pressure decreases 8 psi.
55:53:20	Oxygen tank no. 2 fans turned on.
55:53:20	Stabilization control system electrical disturbance indicates a power transient.
55:53:21	Oxygen tank no. 2 pressure decreases 4 psi.
Abnormal Events During 90 Seconds Preceding the Accident	
55:53:22.718	Stabilization control system electrical disturbance indicates a power transient.
55:53:22.757	1.2-volt decrease in ac bus 2 voltage.
55:53:22.772	11.1-amp rise in fuel cell 3 current for one sample.
55:53:36	Oxygen tank no. 2 pressure begins rise lasting for 24 seconds.
55:53:38.057	11-volt decrease in ac bus 2 voltage for one sample.
55:53:38.085	Stabilization control system electrical disturbance indicates a power transient.

TABLE 4-II.- DETAILED CHRONOLOGY FROM
2.5 MINUTES BEFORE THE ACCIDENT TO 5 MINUTES AFTER THE ACCIDENT - Continued

<u>Time, g.e.t.</u>	<u>Event</u>
55:53:41.172	22.9-amp rise in fuel cell 3 current for one sample.
55:53:41.192	Stabilization control system electrical disturbance indicates a power transient.
55:54:00	Oxygen tank no. 2 pressure rise ends at a pressure of 953.8 psia.
55:54:15	Oxygen tank no. 2 pressure begins to rise.
55:54:30	Oxygen tank no. 2 quantity drops from full scale for 2 seconds and then reads 75.3 percent.
55:54:31	Oxygen tank no. 2 temperature begins to rise rapidly.
55:54:43	Flow rate of oxygen to all three fuel cells begins to decrease.
55:54:45	Oxygen tank no. 2 pressure reaches maximum value of 1008.3 psia.
55:54:48	Oxygen tank no. 2 temperature rises 40° F for one sample (invalid reading).
55:54:51	Oxygen tank no. 2 quantity jumps to off-scale high and then begins to drop until the time of telemetry loss, indicating failed sensor.
55:54:52	Oxygen tank no. 2 temperature reads -151.3° F.
55:54:52.703	Oxygen tank no. 2 temperature suddenly goes off-scale low, indicating failed sensor.
55:54:52.763	Last telemetered pressure from oxygen tank no. 2 before telemetry loss is 995.7 psia.
55:54:53.182	Sudden accelerometer activity on X, Y, and Z axes.
55:54:53.220	Stabilization control system body rate changes begin.

TABLE 4-II.- DETAILED CHRONOLOGY FROM
2.5 MINUTES BEFORE THE ACCIDENT TO 5 MINUTES AFTER THE ACCIDENT - Continued

<u>Time, g.e.t.</u>	<u>Event</u>
55:54:53.323	Oxygen tank no. 1 pressure drops 4.2 psi.
55:54:53.5	2.8-amp rise in total fuel cell current.
55:54:53.542	X, Y, and Z accelerations in CM indicate 1.17g, 0.65g and 0.65g, respectively.
	1.8-Second Data Loss
55:54:53.555	Loss of telemetry begins.
55:54:53.555+	Master caution and warning triggered by dc main bus B undervoltage. Alarm is turned off in 6 seconds. All indications are that the cryogenic oxygen tank no. 2 lost pressure in this time period and the panel separated.
55:54:54.741	Nitrogen pressure in fuel cell 1 is off-scale low indicating failed sensor.
55:54:55.35	Recovery of telemetry data.
	Events During 5 Minutes Following the Accident
55:54:56	Service propulsion system engine valve body temperature begins a rise of 1.65° F in 7 seconds.
55:54:56	Dc main bus A decreases 0.9 volt to 28.5 volts and dc main bus B decreases 0.9 volt to 29.0 volts.
55:54:56	Total fuel cell current is 15 amps higher than the final value before telemetry loss. High current continues for 19 seconds.
55:54:56	Oxygen tank no. 2 temperature reads off-scale high after telemetry recovery, probably indicating failed sensors.
55:54:56	Oxygen tank no. 2 pressure reads off-scale low following telemetry recovery, indicating a broken supply line, a tank pressure below 19 psi, or a failed sensor.

TABLE 4-II.- DETAILED CHRONOLOGY FROM
2.5 MINUTES BEFORE THE ACCIDENT TO 5 MINUTES AFTER THE ACCIDENT - Continued

<u>Time, g.e.t.</u>	<u>Event</u>
55:54:56	Oxygen tank no. 1 pressure reads 781.9 psia and begins to drop steadily.
55:54:57	Oxygen tank no. 2 quantity reads off-scale high following telemetry recovery indicating failed sensor.
55:54:59	The reaction control system helium tank C temperature begins a 1.66° F increase in 36 seconds.
55:55:01	Oxygen flow rates to fuel cells 1 and 3 approached zero after decreasing for 7 seconds.
55:55:02	The surface temperature of the service module oxidizer tank in bay 3 begins a 3.8° F increase in a 15-second period.
55:55:02	The service propulsion system helium tank temperature begins a 3.8° F increase in a 32-second period.
55:55:09	Dc main bus A voltage recovers to 29.0 volts; dc main bus B recovers to 28.8 volts.
55:55:20	Crew reports, "I believe we've had a problem here."
55:55:35	Crew reports, "We've had a main B bus undervolt."
55:55:49	Oxygen tank no. 2 temperature begins steady drop lasting 59 seconds, probably indicating failed sensor.
55:56:10	Crew reports, "Okay right now, Houston. The voltage is looking good, and we had a pretty large bang associated with the caution and warning there. And as I recall, main B was the one that had had an amp spike on it once before."
55:56:38	Oxygen tank no. 2 quantity becomes erratic for 69 seconds before assuming an off-scale-low state, indicating failed sensor.

TABLE 4-II.- DETAILED CHRONOLOGY FROM
2.5 MINUTES BEFORE THE ACCIDENT TO 5 MINUTES AFTER THE ACCIDENT - Concluded

<u>Time, g.e.t.</u>	<u>Event</u>
55:57:04	Crew reports, "That jolt must have rocked the sensor on--see now--oxygen quantity 2. It was oscillating down around 20 to 60 percent. Now it's full-scale high again."
55:57:39	Master caution and warning triggered by dc main bus B undervoltage. Alarm is turned off in 6 seconds.
55:57:40	Dc main bus B drops below 26.25 volts and continues to fall rapidly.
55:57:44	Ac bus 2 fails within 2 seconds
55:57:45	Fuel cell 3 fails.
55:57:59	Fuel cell 1 current begins to decrease.
55:58:02	Master caution and warning caused by ac bus 2 being reset. Alarm is turned off after 2 seconds.
55:58:06	Master caution and warning triggered by dc main bus A undervoltage. Alarm is turned off in 13 seconds.
55:58:07	Dc main bus A drops below 26.25 volts and in the next few seconds levels off at 25.5 volts.
55:58:07	Crew reports, "ac 2 is showing zip."
55:58:25	Crew reports, "Yes, we got a main bus A undervolt now, too, showing. It's reading about 25-1/2. Main B is reading zip right now."
56:00:06	Master caution and warning triggered by high hydrogen flow rate to fuel cell 2. Alarm is turned off in 2 seconds.

PART 4. SUMMARY ANALYSIS OF THE ACCIDENT

Combustion in oxygen tank no. 2 led to failure of that tank, damage to oxygen tank no. 1 or its lines or valves adjacent to tank no. 2, removal of the bay 4 panel and, through the resultant loss of all three fuel cells, to the decision to abort the Apollo 13 mission. In the attempt to determine the cause of ignition in oxygen tank no. 2, the course of propagation of the combustion, the mode of tank failure, and the way in which subsequent damage occurred, the Board has carefully sifted through all available evidence and examined the results of special tests and analyses conducted by the Apollo organization and by or for the Board after the accident. (For more information on details of mission events, design, manufacture and test of the system, and special tests and analyses conducted in this investigation, refer to Appendices B, C, D, E, and F of this report.)

Although tests and analyses are continuing, sufficient information is now available to provide a reasonably clear picture of the nature of the accident and the events which led up to it. It is now apparent that the extended heater operation at KSC damaged the insulation on wiring in the tank and thus made the wiring susceptible to the electrical short circuit which probably initiated combustion within the tank. While the exact point of initiation of combustion may never be known with certainty, the nature of the occurrence is sufficiently understood to permit taking corrective steps to prevent its recurrence.

The Board has identified the most probable failure mode.

The following discussion treats the accident in its key phases: initiation, propagation of combustion, loss of oxygen tank no. 2 system integrity, and loss of oxygen tank no. 1 system integrity.

INITIATION

Key Data

55:53:20* Oxygen tank no. 2 fans turned on.
55:53:22.757 1.2-volt decrease in ac bus 2 voltage.

*In evaluating telemetry data, consideration must be given to the fact that the Apollo pulse code modulation (PCM) system samples data in time and quantizes in amplitude. For further information, reference may be made to Part B7 of Appendix B.

55:53:22.772 11.1-ampere "spike" recorded in fuel cell 3 current followed by drop in current and rise in voltage typical of removal of power from one fan motor--indicating opening of motor circuit.

55:53:36 Oxygen tank no. 2 pressure begins to rise.

The evidence points strongly to an electrical short circuit with arcing as the initiating event. About 2.7 seconds after the fans were turned on in the SM oxygen tanks, an 11.1-ampere current spike and simultaneously a voltage-drop spike were recorded in the spacecraft electrical system. Immediately thereafter, current drawn from the fuel cells decreased by an amount consistent with the loss of power to one fan. No other changes in spacecraft power were being made at the time. No power was on the heaters in the tanks at the time and the quantity gage and temperature sensor are very low power devices. The next anomalous event recorded was the beginning of a pressure rise in oxygen tank no. 2, 13 seconds later. Such a time lag is possible with low-level combustion at the time. These facts point to the likelihood that an electrical short circuit with arcing occurred in the fan motor or its leads to initiate the accident sequence. The energy available from the short circuit was probably 10 to 20 joules. Tests conducted during this investigation have shown that this energy is more than adequate to ignite Teflon of the type contained within the tank. (The quantity gage in oxygen tank no. 2 had failed at 46:40 g.e.t. There is no evidence tying the quantity gage failure directly to accident initiation, particularly in view of the very low energy available from the gage.)

This likelihood of electrical initiation is enhanced by the high probability that the electrical wires within the tank were damaged during the abnormal detanking operation at KSC prior to launch.

Furthermore, there is no evidence pointing to any other mechanism of initiation.

PROPAGATION OF COMBUSTION

Key Data

55:53:36 Oxygen tank no. 2 pressure begins rise (same event noted previously).

55:53:38.057 11-volt decrease recorded in ac bus 2 voltage.

55:53:41.172 22.9-ampere "spike" recorded in fuel cell 3 current, followed by drop in current and rise in voltage typical of one fan motor -- indicating opening of another motor circuit.

55:54:00 Oxygen tank no. 2 pressure levels off at 954 psia.

55:54:15 Oxygen tank no. 2 pressure begins to rise again.

55:54:30 Oxygen tank no. 2 quantity gage reading drops from full scale (to which it had failed at 46:40 g.e.t.) to zero and then read 75-percent full. This behavior indicates the gage short circuit may have corrected itself.

55:54:31 Oxygen tank no. 2 temperature begins to rise rapidly.

55:54:45 Oxygen tank no. 2 pressure reading reaches maximum recorded value of 1008 psia.

55:54:52.763 Oxygen tank no. 2 pressure reading had dropped to 996 psia.

The available evidence points to a combustion process as the cause of the pressure and temperature increases recorded in oxygen tank no. 2. The pressure reading for oxygen tank no. 2 began to increase about 13 seconds after the first electrical spike, and about 55 seconds later the temperature began to increase. The temperature sensor reads local temperature, which need not represent bulk fluid temperature. Since the rate of pressure rise in the tank indicates a relatively slow propagation of burning, it is likely that the region immediately around the temperature sensor did not become heated until this time.

There are materials within the tank that can, if ignited in the presence of supercritical oxygen, react chemically with the oxygen in exothermic chemical reactions. The most readily reactive is Teflon used for electrical insulation in the tank. Also potentially reactive are metals, particularly aluminum. There is more than sufficient Teflon in the tank, if reacted with oxygen, to account for the pressure and temperature increases recorded. Furthermore, the pressure rise took place over a period of more than 69 seconds, a relatively long period, and one which would be more likely characteristic of Teflon combustion than metal-oxygen reactions.

While the data available on the combustion of Teflon in supercritical oxygen in zero-g are extremely limited, those which are available indicate that the rate of combustion is generally consistent with these

observations. The cause of the 15-second period of relatively constant pressure first indicated at 55:53:59.763 has not been precisely determined; it is believed to be associated with a change in reaction rate as combustion proceeded through various Teflon elements.

While there is enough electrical power in the tank to cause ignition in the event of a short circuit or abnormal heating in defective wire, there is not sufficient electric power to account for all of the energy required to produce the observed pressure rise.

LOSS OF OXYGEN TANK NO. 2 SYSTEM INTEGRITY

Key Data

55:54:52	Last valid temperature indication (-151° F) from oxygen tank no. 2.
55:54:52.763	Last pressure reading from oxygen tank no. 2 before loss of data--996 psia.
55:54:53.182	Sudden accelerometer activity on X, Y, and Z axes.
55:54:53.220	Stabilization control system body rate changes begin.
55:54:53.555*	Loss of telemetry data begins.
55:54:55.35	Recovery of telemetry data.
55:54:56	Various temperature indications in SM begin slight rises.
55:54:56	Oxygen tank no. 2 temperature reads off-scale high.
55:54:56	Oxygen tank no. 2 pressure reads off-scale low.

After the relatively slow propagation process described above took place, there was a relatively abrupt loss of oxygen tank no. 2 integrity. About 69 seconds after the pressure began to rise, it reached the peak recorded, 1008 psia, the pressure at which the cryogenic oxygen tank relief valve is designed to be fully open. Pressure began a decrease for 8 seconds, dropping to 996 psia before readings were lost. Virtually

*Several bits of data have been obtained from this "loss of telemetry data" period.

all signals from the spacecraft were lost about 1.85 seconds after the last presumably valid reading from within the tank, a temperature reading, and 0.8 second after the last presumably valid pressure reading (which may or may not reflect the pressure within the tank itself since the pressure transducer is about 20 feet of tubing length distant). Abnormal spacecraft accelerations were recorded approximately 0.42 second after the last pressure reading and approximately 0.38 second before the loss of signal. These facts all point to a relatively sudden loss of integrity. At about this time, several solenoid valves, including the oxygen valves feeding two of the three fuel cells, were shocked to the closed position. The "bang" reported by the crew also probably occurred in this time period. Telemetry signals from Apollo 13 were lost for a period of 1.8 seconds. When signal was reacquired, all instrument indicators from oxygen tank no. 2 were off-scale, high or low. Temperatures recorded by sensors in several different locations in the SM showed slight increases in the several seconds following reacquisition of signal. Photographs taken later by the Apollo 13 crew as the SM was jettisoned show that the bay 4 panel was ejected, undoubtedly during this event.

Data are not adequate to determine precisely the way in which the oxygen tank no. 2 system lost its integrity. However, available information, analyses, and tests performed during this investigation indicate that most probably the combustion within the pressure vessel ultimately led to localized heating and failure at the pressure vessel closure. It is at this point, the upper end of the quantity probe, that the 1/2-inch Inconel conduit is located, through which the Teflon-insulated wires enter the pressure vessel. It is likely that the combustion progressed along the wire insulation and reached this location where all of the wires come together. This, possibly augmented by ignition of the metal in the upper end of the probe, led to weakening and failure of the closure or the conduit, or both.

Failure at this point would lead immediately to pressurization of the tank dome, which is equipped with a rupture disc rated at about 75 psi. Rupture of this disc or of the entire dome would then release oxygen, accompanied by combustion products, into bay 4. The accelerations recorded were probably caused by this release.

Release of the oxygen then began to pressurize the oxygen shelf space of bay 4. If the hole formed in the pressure vessel were large enough and formed rapidly enough, the escaping oxygen alone would be adequate to blow off the bay 4 panel. However, it is also quite possible that the escape of oxygen was accompanied by combustion of Mylar and Kapton (used extensively as thermal insulation in the oxygen shelf compartment, figure 4-11, and in the tank dome) which would augment the

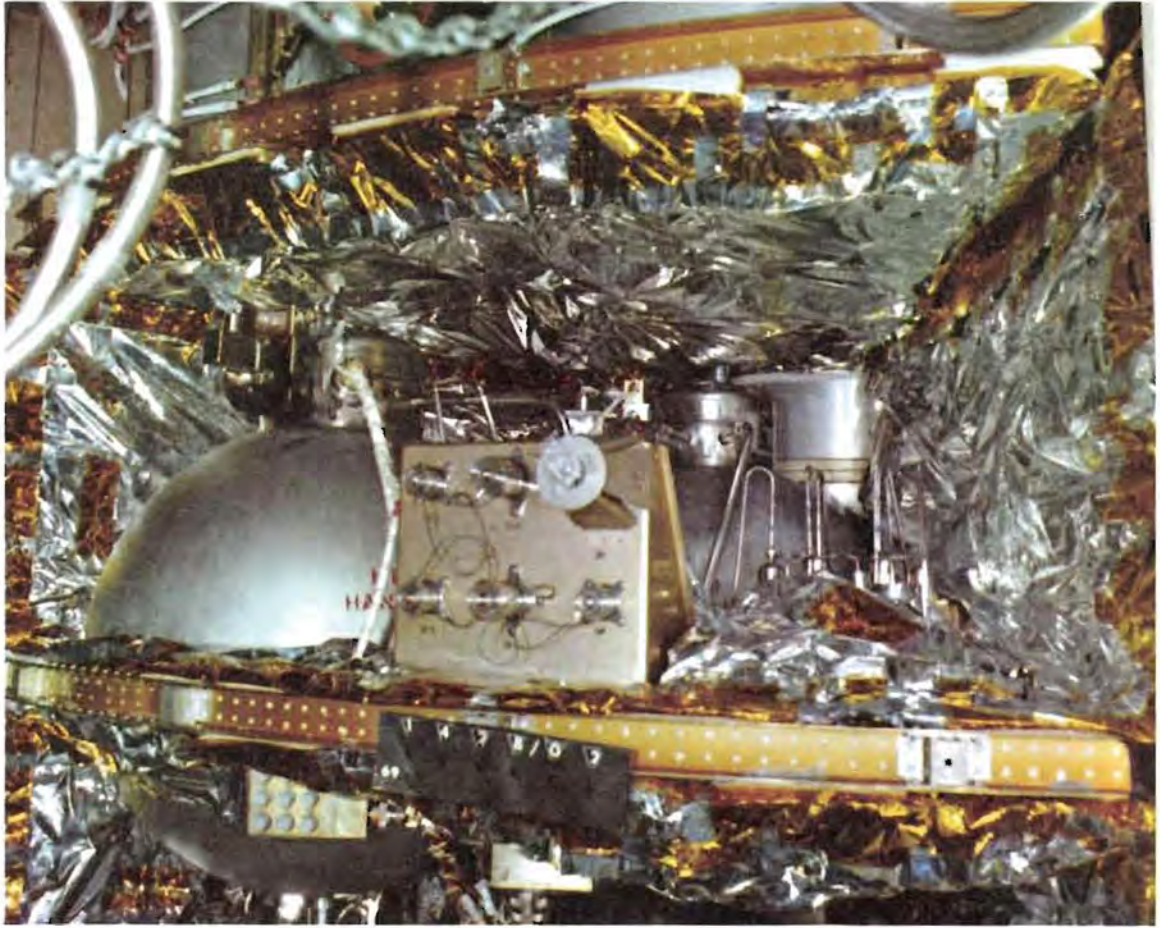

4-11.-
Figure ~~XX-XX~~ Closeup view of oxygen tank shelf.

pressure caused by the oxygen itself. The slight temperature increases recorded at various SM locations indicate that combustion external to the tank probably took place. Further testing may shed additional light on the exact mechanism of panel ejection. The ejected panel then struck the high-gain antenna, disrupting communications from the spacecraft for the 1.8 seconds.

LOSS OF OXYGEN TANK NO. 1 INTEGRITY

Key Data

55:54:53.323 Oxygen tank no. 1 pressure drops 4 psia (from 883 psia to 879 psia).

55:54:53.555 to Loss of telemetry data.
55:54:55.35

55:54:56 Oxygen tank no. 1 pressure reads 782 psia and drops steadily. Pressure drops over a period of 130 minutes to the point at which it was insufficient to sustain operation of fuel cell no. 2.

There is no clear evidence of abnormal behavior associated with oxygen tank no. 1 prior to loss of signal, although the one data bit (4 psi) drop in pressure in the last tank no. 1 pressure reading prior to loss of signal may indicate that a problem was beginning. Immediately after signal strength was regained, data show that tank no. 1 system had lost its integrity. Pressure decreases were recorded over a period of approximately 130 minutes, indicating that a relatively slow leak had developed in the tank no. 1 system. Analysis has indicated that the leak rate is less than that which would result from a completely ruptured line, but could be consistent with a partial line rupture or a leaking check or relief valve.

Since there is no evidence that there was any anomalous condition arising within oxygen tank no. 1, it is presumed that the loss of oxygen tank no. 1 integrity resulted from the oxygen tank no. 2 system failure. The relatively sudden, and possibly violent, event associated with loss of integrity of the oxygen tank no. 2 system could have ruptured a line to oxygen tank no. 1, or have caused a valve to leak because of mechanical shock.

PART 5. APOLLO 13 RECOVERY

UNDERSTANDING THE PROBLEM

In the period immediately following the caution and warning alarm for main bus B undervoltage, and the associated "bang" reported by the crew, the cause of the difficulty and the degree of its seriousness were not apparent.

The 1.8-second loss of telemetered data was accompanied by the switching of the CSM high-gain antenna mounted on the SM adjacent to bay 4 from narrow beam width to wide beam width. The high-gain antenna does this automatically 200 milliseconds after its directional lock on the ground signal has been lost.

A confusing factor was the repeated firings of various SM attitude control thrusters during the period after data loss. In all probability, these thrusters were being fired to overcome the effects that oxygen venting and panel blowoff were having on spacecraft attitude, but it was believed for a time that perhaps the thrusters were malfunctioning.

The failure of oxygen tank no. 2 and consequent removal of the bay 4 panel produced a shock which closed valves in the oxygen supply lines to fuel cells 1 and 3. These fuel cells ceased to provide power in about 3 minutes, when the supply of oxygen between the closed valves and the cells was depleted. Fuel cell 2 continued to power ac bus 1 through dc main bus A, but the failure of fuel cell 3 left dc main bus B and ac bus 2 unpowered (see fig. 4-12). The oxygen tank no. 2 temperature and quantity gages were connected to ac bus 2 at the time of the accident. Thus, these parameters could not be read once fuel cell 3 failed at 55:57:44 until power was applied to ac bus 2 from main bus A.

The crew was not alerted to closure of the oxygen feed valves to fuel cells 1 and 3 because the valve position indicators in the CM were arranged to give warning only if both the oxygen and hydrogen valves closed. The hydrogen valves remained open. The crew had not been alerted to the oxygen tank no. 2 pressure rise or to its subsequent drop because a hydrogen tank low pressure warning had blocked the cryogenic subsystem portion of the caution and warning system several minutes before the accident.

When the crew heard the bang and got the master alarm for low dc main bus B voltage, the Commander was in the lower equipment bay of the command module, stowing a television camera which had just been in use.

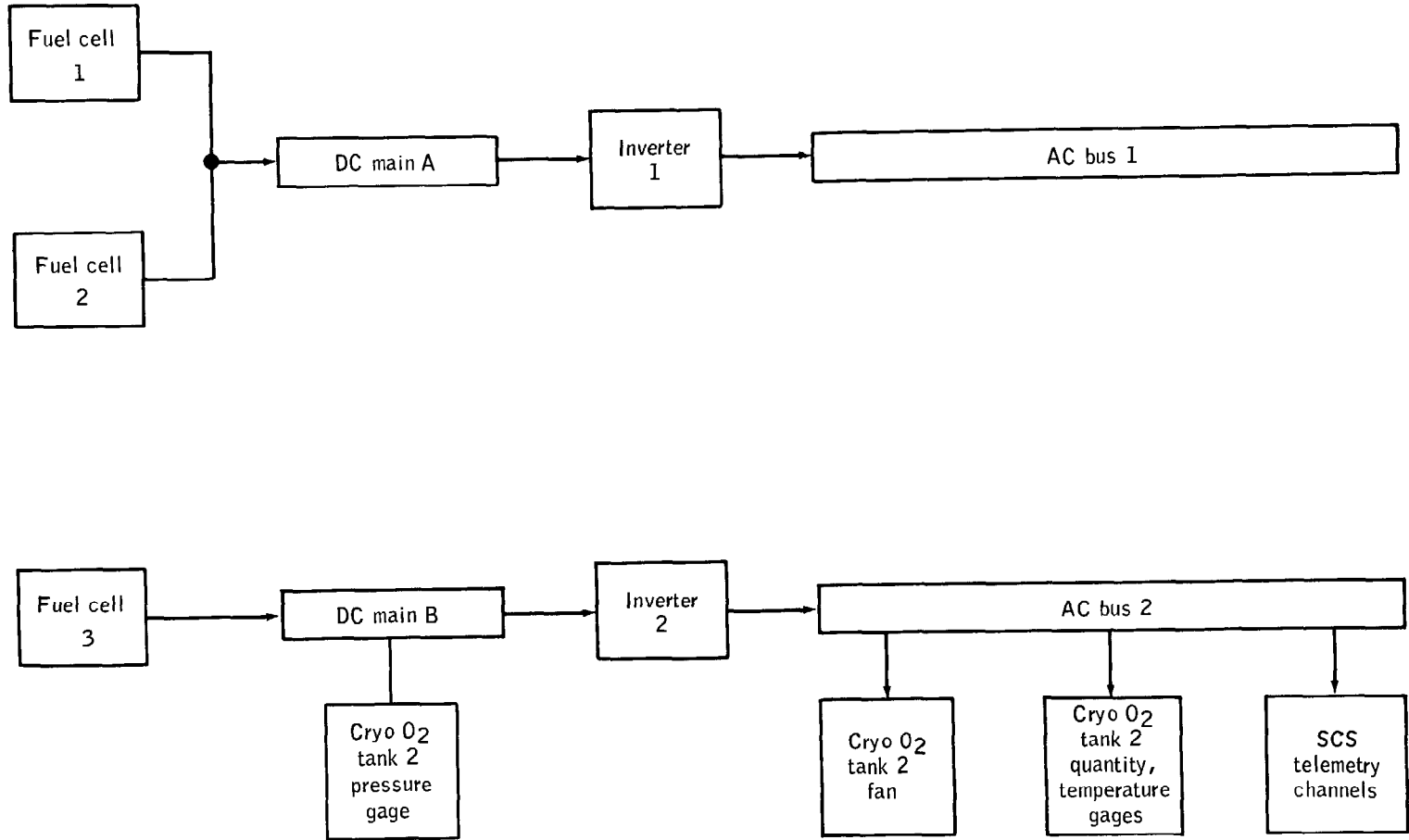

Figure 4-12.- Electrical configuration at 55:54:53 g.e.t.

The Lunar Module Pilot was in the tunnel between the CSM and the LM, returning to the CSM. The Command Module Pilot was in the left-hand couch, monitoring spacecraft performance. Because of the master alarm indicating low voltage, the CMP moved across to the right-hand couch where CSM voltages can be observed. He reported that voltages were "looking good" at 55:56:10. At this time, main bus B had recovered and fuel cell 3 did not fail for another 1-1/2 minutes. He also reported fluctuations in the oxygen tank no. 2 quantity, followed by a return to the off-scale high position. (See fig. 4-13 for CM panel arrangement).

When fuel cells 1 and 3 electrical output readings went to zero, the ground controllers could not be certain that the cells had not somehow been disconnected from their respective busses and were not otherwise all right. Attention continued to be focused on electrical problems.

Five minutes after the accident, controllers asked the crew to connect fuel cell 3 to dc main bus B in order to be sure that the configuration was known. When it was realized that fuel cells 1 and 3 were not functioning, the crew was directed to perform an emergency powerdown to lower the load on the remaining fuel cell. Observing the rapid decay in oxygen tank no. 1 pressure, controllers asked the crew to switch power to the oxygen tank no. 2 instrumentation. When this was done, and it was realized that oxygen tank no. 2 had failed, the extreme seriousness of the situation became clear.

During the succeeding period, efforts were made to save the remaining oxygen in the oxygen tank no. 1. Several attempts were made, but had no effect. The pressure continued to decrease.

It was obvious by about 1-1/2 hours after the accident that the oxygen tank no. 1 leak could not be stopped and that shortly it would be necessary to use the LM as a "lifeboat" for the remainder of the mission.

By 58:40 g.e.t., the LM had been activated, the inertial guidance reference transferred from the CSM guidance system to the LM guidance system, and the CSM systems were turned off.

RETURN TO EARTH

The remainder of the mission was characterized by two main activities--planning and conducting the necessary propulsion maneuvers to return the spacecraft to Earth, and managing the use of consumables in such a way that the LM, which is designed for a basic mission with two crewmen for a relatively short duration, could support three men and serve as the actual control vehicle for the time required.

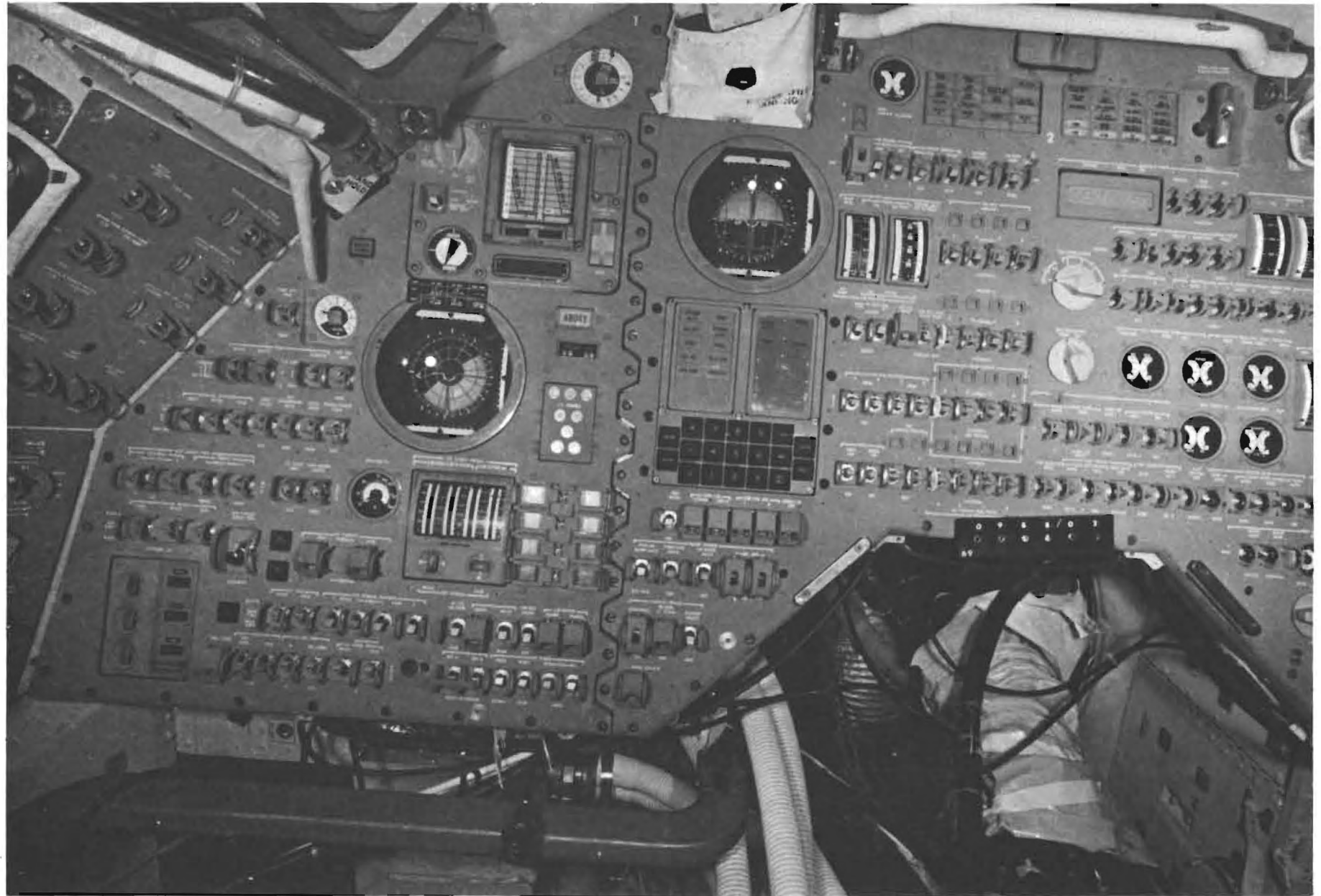

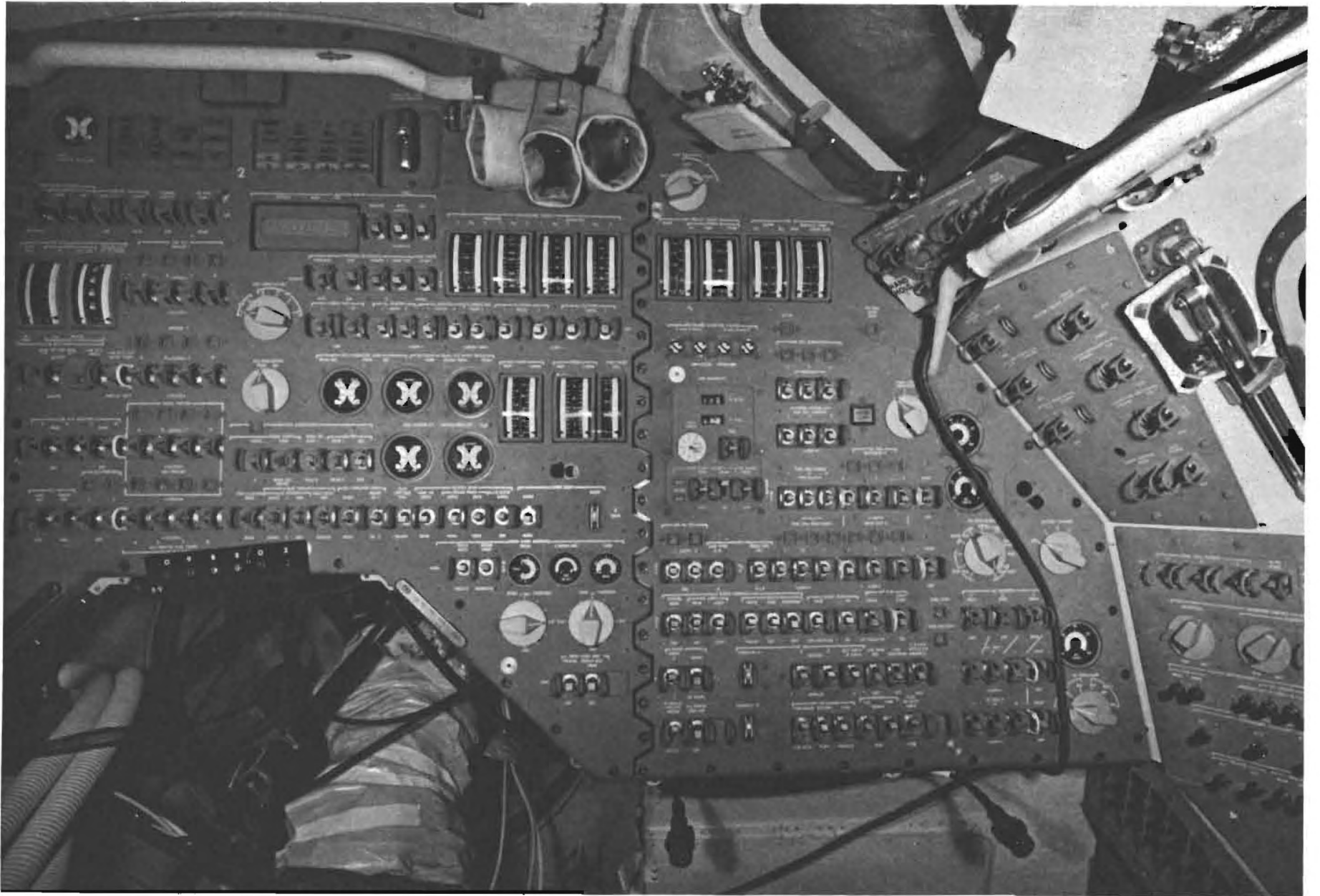

Figure 4-13.- Main display panel.

One significant anomaly was noted during the remainder of the mission. At about 97 hours 14 minutes into the mission, the LMP reported hearing a "thump" and observing venting from the LM. Subsequent data review shows that the LM electrical power system experienced a brief but major abnormal current flow at that time. There is no evidence that this anomaly was related to the accident. Analysis by the Apollo organization is continuing.

A number of propulsion options were developed and considered. It was necessary to return the spacecraft to a free-return trajectory and to make any required midcourse corrections. Normally, the service propulsion system (SPS) in the SM would be used for such maneuvers. However, because of the high electrical power requirements for using that engine, and in view of its uncertain condition and the uncertain nature of the structure of the SM after the accident, it was decided to use the LM descent engine if possible.

The minimum practical return time was 133 hours g.e.t. to the Atlantic Ocean, and the maximum was 152 hours g.e.t. to the Indian Ocean. Recovery forces were deployed in the Pacific. The return path selected was for splashdown in the Pacific Ocean at 142:40 g.e.t. This required a minimum of two burns of the LM descent engine. A third burn was subsequently made to correct the normal maneuver execution variations in the first two burns. One small velocity adjustment was also made with reaction control system thrusters. All burns were satisfactory. Figures 4-14 and 4-15 depict the flight plan followed from the time of the accident to splashdown.

The most critical consumables were water, used to cool the CSM and LM systems during use; CSM and LM battery power, the CSM batteries being for use during reentry and the LM batteries being needed for the rest of the mission; LM oxygen for breathing; and lithium hydroxide (LiOH) filter cannisters used to remove carbon dioxide from the spacecraft cabin atmosphere. These consumables, and in particular the water and LiOH cannisters, appeared to be extremely marginal in quantity shortly after the accident, but once the LM was powered down to conserve electric power and to generate less heat and thus use less water, the situation improved greatly. Engineers at MSC developed a method which allowed the crew to use materials on board to fashion a device allowing use of the CM LiOH cannisters in the LM cabin atmosphere cleaning system (see fig. 4-16). At splashdown, many hours of each consumable remained available (see figs. 4-17 through 4-19 and table 4-III).

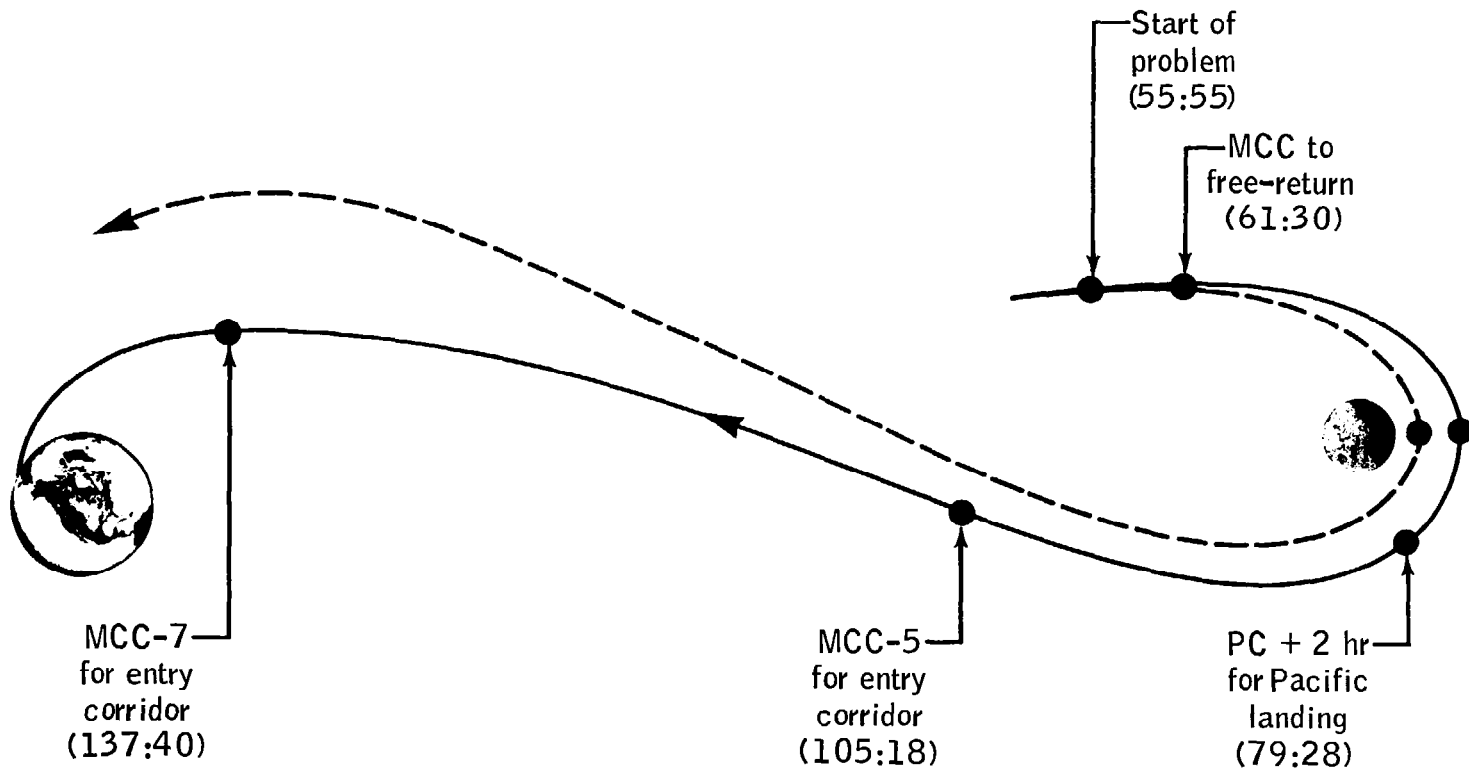

Figure 4-14.- Translunar trajectory phase.

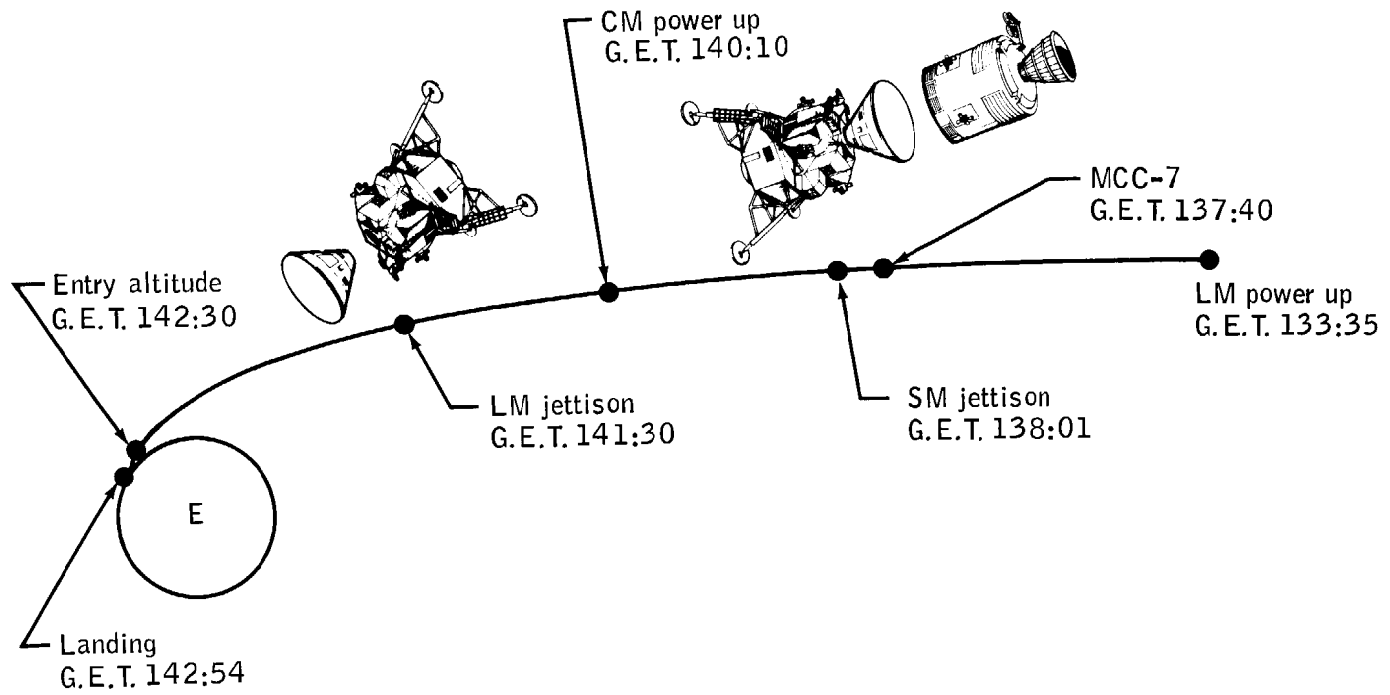

Figure 4-15.- Final trajectory phase.

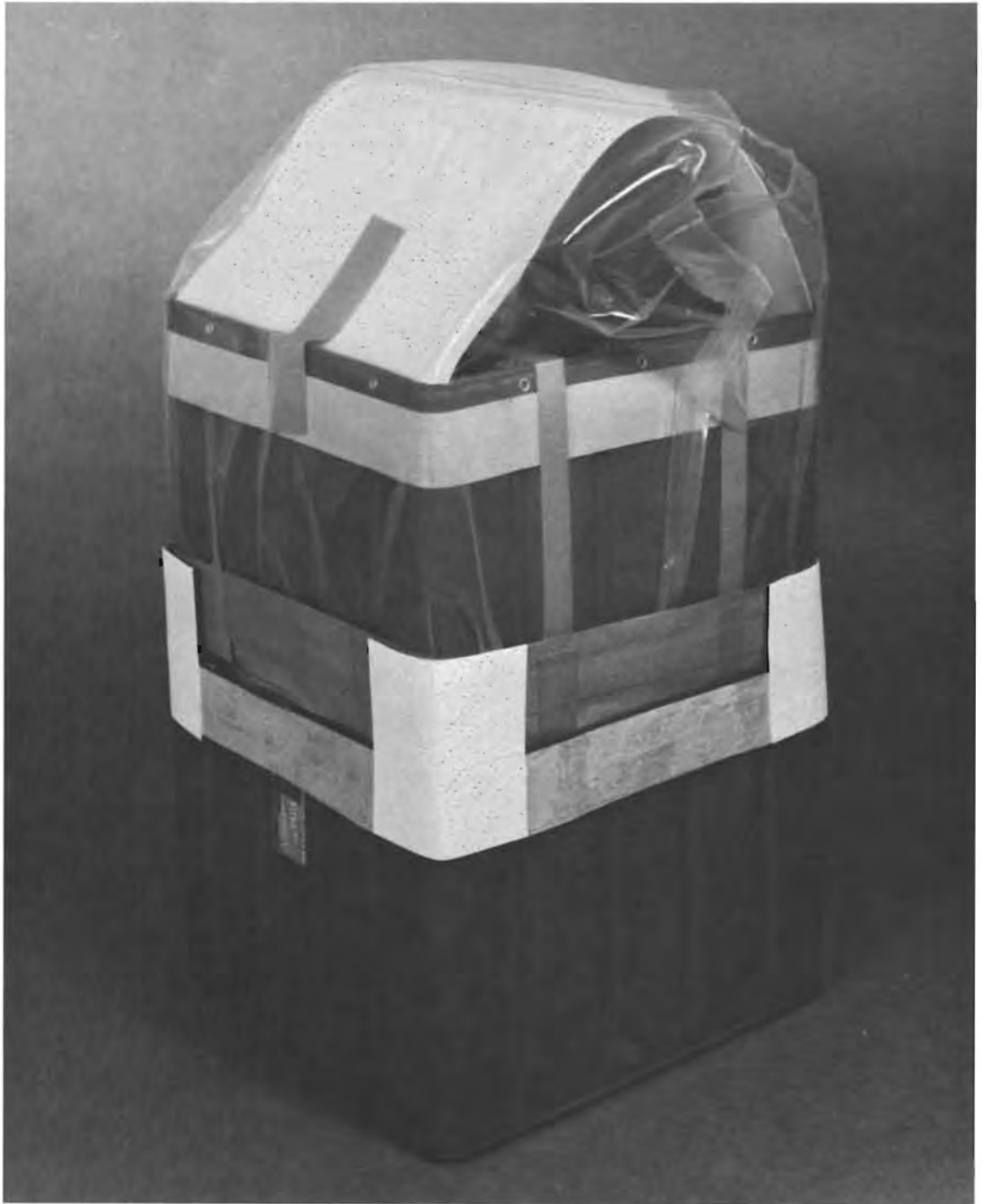

Figure 4-16.- Lithium hydroxide canister modification.

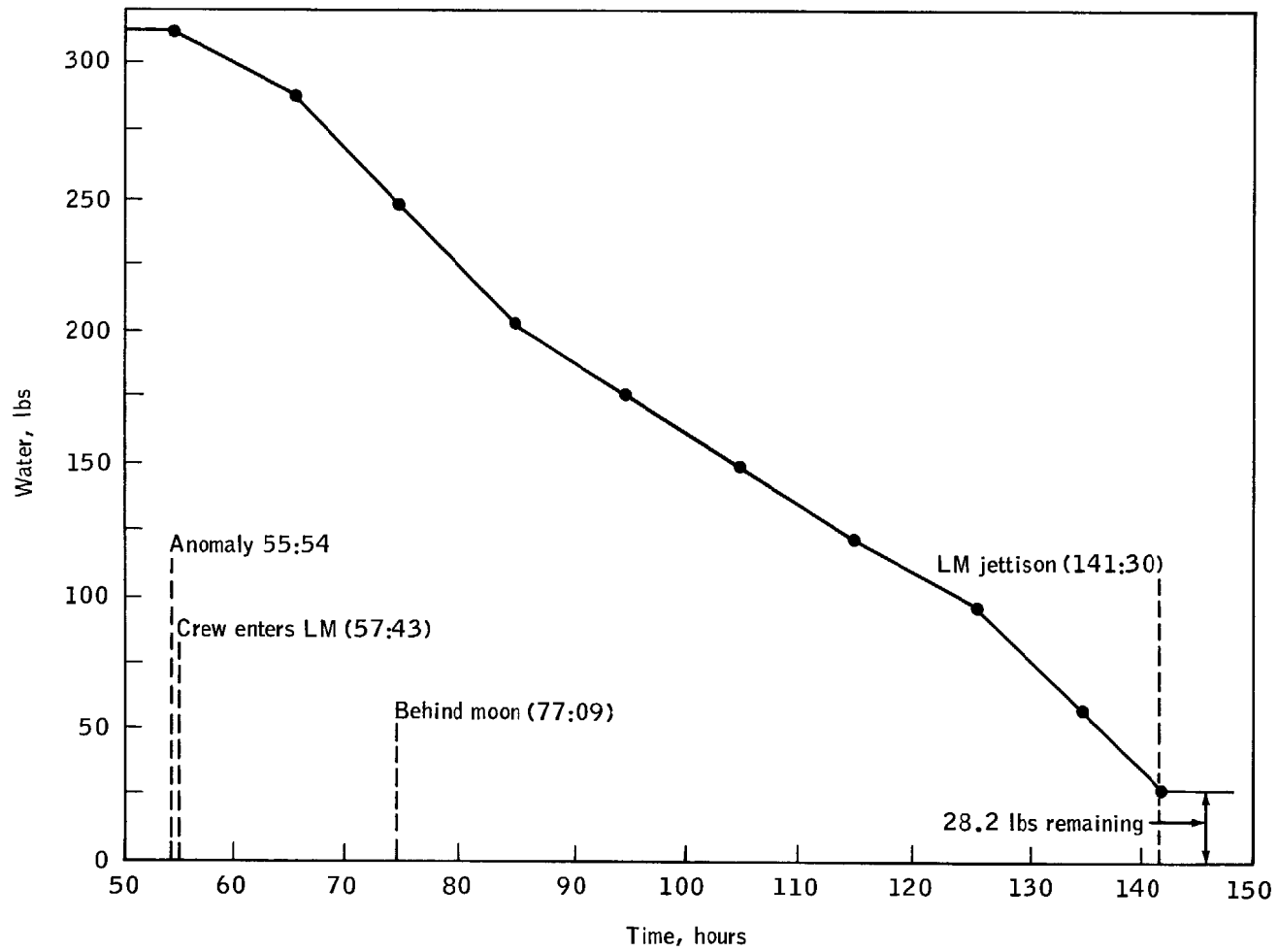

Figure 4-17.- Usable remaining water.

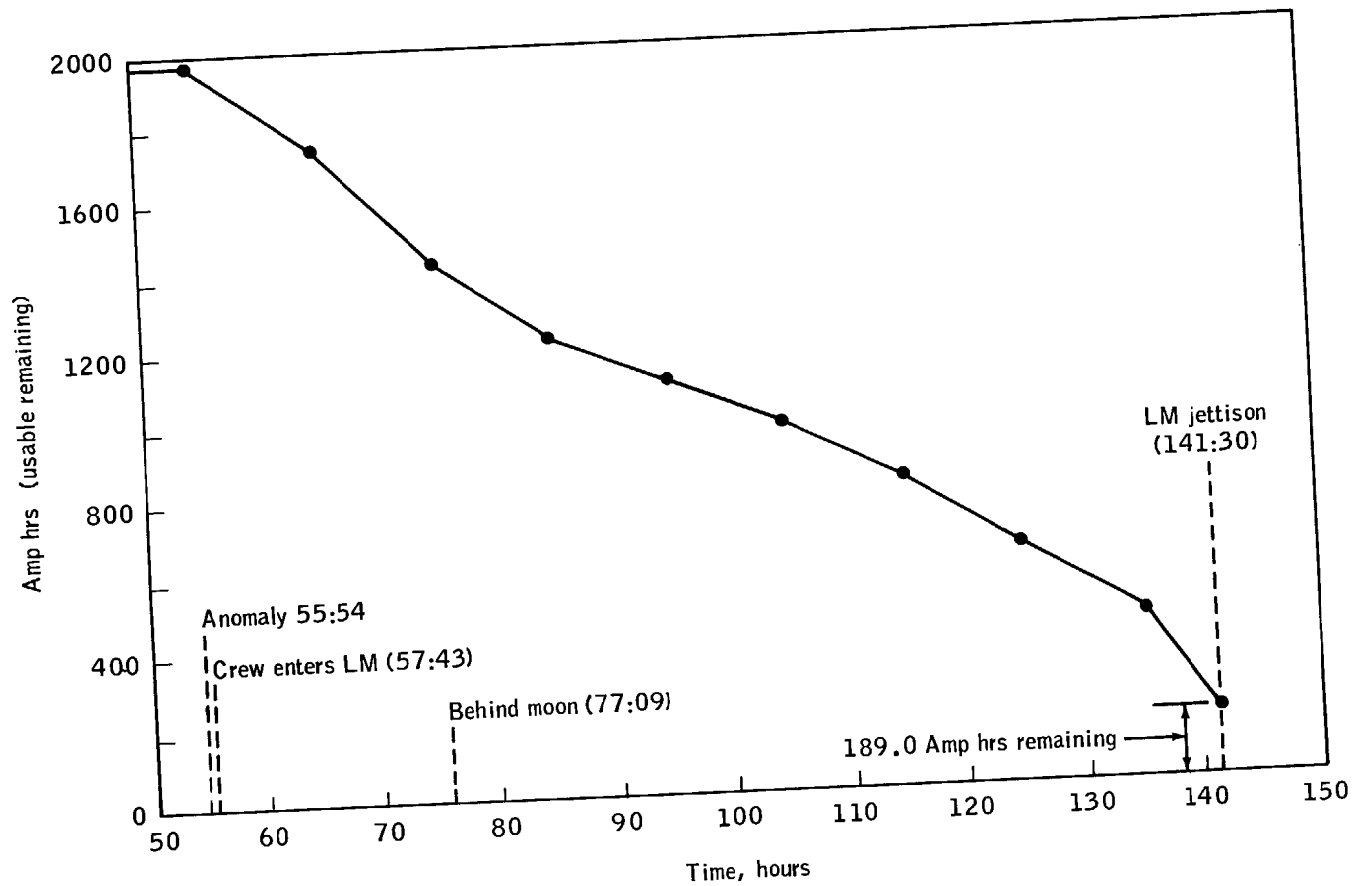

Figure 4-18.- Electrical power system consumables status.

45-7

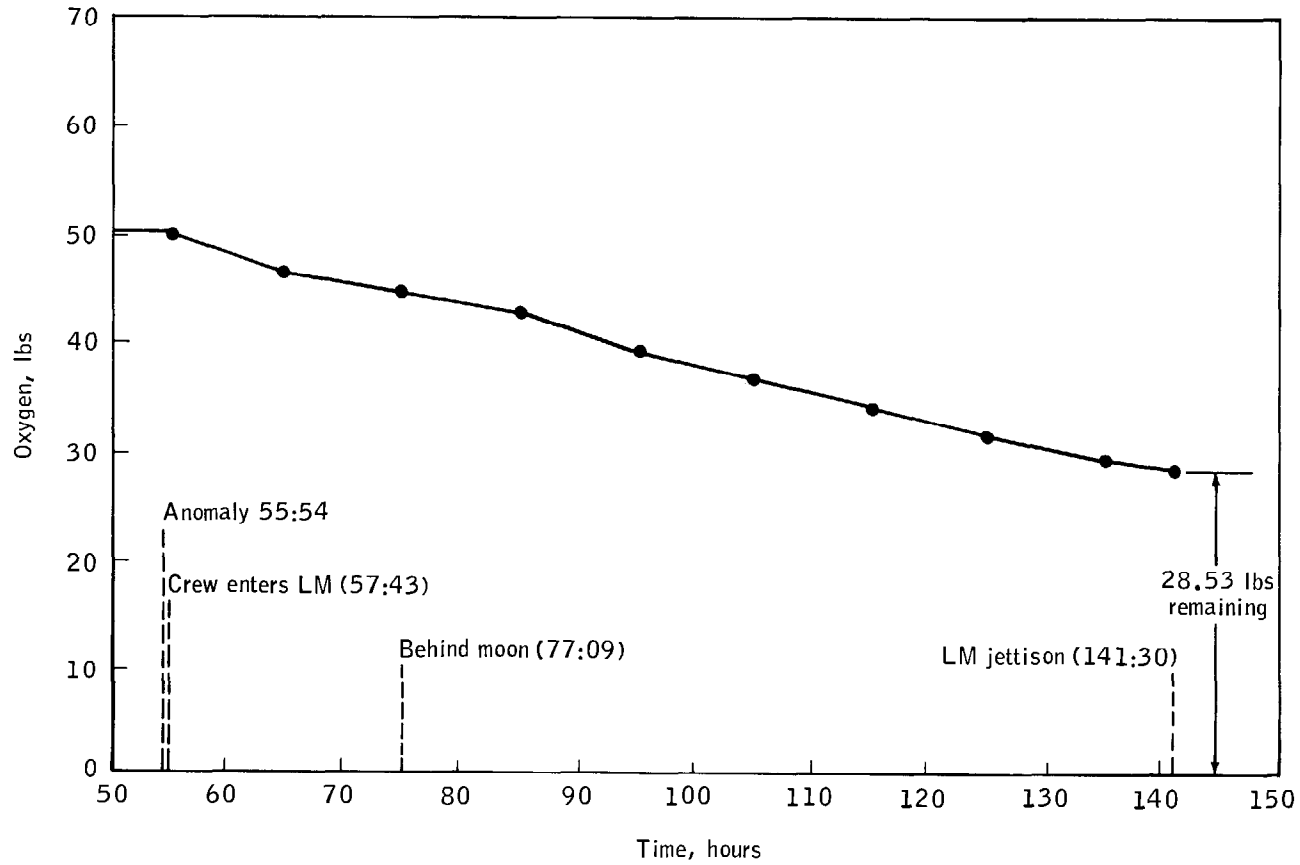

Figure 4-19.- Usable remaining oxygen.

TABLE 4-III.- CABIN ATMOSPHERE CARBON DIOXIDE
REMOVAL BY LITHIUM HYDROXIDE

Required	85 hours
Available in LM	53 hours
Available in CM	182 hours

A more detailed recounting of the events during the Apollo 13 launch countdown and mission will be found in Appendix B to this report.

This page left blank intentionally.

CHAPTER 5

FINDINGS, DETERMINATIONS, AND RECOMMENDATIONS

PART 1. INTRODUCTION

The following findings, determinations, and recommendations are the product of about 7 weeks of concentrated review of the Apollo 13 accident by the Apollo 13 Review Board. They are based on that review, on the accident investigation by the Manned Spacecraft Center (MSC) and its contractors, and on an extensive series of special tests and analyses performed by or for the Board and its Panels.

Sufficient work has been done to identify and understand the nature of the malfunction and the direction which the corrective actions must take. All indications are that an electrically initiated fire in oxygen tank no. 2 in the service module (SM) was the cause of the accident. Accordingly, the Board has concentrated on this tank; on its design, manufacture, test, handling, checkout, use, failure mode, and eventual effects on the rest of the spacecraft. The accident is generally understood, and the most probable cause has been identified. However, at the time of this report, some details of the accident are not completely clear.

Further tests and analyses, which will be carried out under the overall direction of MSC, will continue to generate new information relative to this accident. It is possible that this evidence may lead to conclusions differing in detail from those which can be drawn now. However, it is most unlikely that fundamentally different results will be obtained.

Recommendations are provided as to the general direction which the corrective actions should take. Significant modifications should be made to the SM oxygen storage tanks and related equipments. The modified hardware should go through a rigorous requalification test program. This is the responsibility of the Apollo organization in the months ahead.

In reaching its findings, determinations, and recommendations, it was necessary for the Board to review critically the equipment and the organizational elements responsible for it. It was found that the accident was not the result of a chance malfunction in a statistical sense, but rather resulted from an unusual combination of mistakes, coupled with a somewhat deficient and unforgiving design. In brief, this is what happened:

a. After assembly and acceptance testing, the oxygen tank no. 2 which flew on Apollo 13 was shipped from Beech Aircraft Corporation to North American Rockwell (NR) in apparently satisfactory condition.

b. It is now known, however, that the tank contained two protective thermostatic switches on the heater assembly, which were inadequate and would subsequently fail during ground test operations at Kennedy Space Center (KSC).

c. In addition, it is probable that the tank contained a loosely fitting fill tube assembly. This assembly was probably displaced during subsequent handling, which included an incident at the prime contractor's plant in which the tank was jarred.

d. In itself, the displaced fill tube assembly was not particularly serious, but it led to the use of improvised detanking procedures at KSC which almost certainly set the stage for the accident.

e. Although Beech did not encounter any problem in detanking during acceptance tests, it was not possible to detank oxygen tank no. 2 using normal procedures at KSC. Tests and analyses indicate that this was due to gas leakage through the displaced fill tube assembly.

f. The special detanking procedures at KSC subjected the tank to an extended period of heater operation and pressure cycling. These procedures had not been used before, and the tank had not been qualified by test for the conditions experienced. However, the procedures did not violate the specifications which governed the operation of the heaters at KSC.

g. In reviewing these procedures before the flight, officials of NASA, NR, and Beech did not recognize the possibility of damage due to overheating. Many of these officials were not aware of the extended heater operation. In any event, adequate thermostatic switches might have been expected to protect the tank.

h. A number of factors contributed to the presence of inadequate thermostatic switches in the heater assembly. The original 1962 specifications from NR to Beech Aircraft Corporation for the tank and heater assembly specified the use of 28 V dc power, which is used in the spacecraft. In 1965, NR issued a revised specification which stated that the heaters should use a 65 V dc power supply for tank pressurization; this was the power supply used at KSC to reduce pressurization time. Beech ordered switches for the Block II tanks but did not change the switch specifications to be compatible with 65 V dc.

i. The thermostatic switch discrepancy was not detected by NASA, NR, or Beech in their review of documentation, nor did tests identify the incompatibility of the switches with the ground support equipment (GSE) at KSC, since neither qualification nor acceptance testing required switch cycling under load as should have been done. It was a serious oversight in which all parties shared.

j. The thermostatic switches could accommodate the 65 V dc during tank pressurization because they normally remained cool and closed. However, they could not open without damage with 65 V dc power applied. They were never required to do so until the special detanking. During this

procedure, as the switches started to open when they reached their upper temperature limit, they were welded permanently closed by the resulting arc and were rendered inoperative as protective thermostats.

k. Failure of the thermostatic switches to open could have been detected at KSC if switch operation had been checked by observing heater current readings on the oxygen tank heater control panel. Although it was not recognized at that time, the tank temperature readings indicated that the heaters had reached their temperature limit and switch opening should have been expected.

l. As shown by subsequent tests, failure of the thermostatic switches probably permitted the temperature of the heater tube assembly to reach about 1000° F in spots during the continuous 8-hour period of heater operation. Such heating has been shown by tests to severely damage the Teflon insulation on the fan motor wires in the vicinity of the heater assembly. From that time on, including pad occupancy, the oxygen tank no. 2 was in a hazardous condition when filled with oxygen and electrically powered.

m. It was not until nearly 56 hours into the mission, however, that the fan motor wiring, possibly moved by the fan stirring, short circuited and ignited its insulation by means of an electric arc. The resulting combustion in the oxygen tank probably overheated and failed the wiring conduit where it enters the tank, and possibly a portion of the tank itself.

n. The rapid expulsion of high-pressure oxygen which followed, possibly augmented by combustion of insulation in the space surrounding the tank, blew off the outer panel to bay 4 of the SM, caused a leak in the high-pressure system of oxygen tank no. 1, damaged the high-gain antenna, caused other miscellaneous damage, and aborted the mission.

The accident is judged to have been nearly catastrophic. Only outstanding performance on the part of the crew, Mission Control, and other members of the team which supported the operations successfully returned the crew to Earth.

In investigating the accident to Apollo 13, the Board has also attempted to identify those additional technical and management lessons which can be applied to help assure the success of future space flight missions; several recommendations of this nature are included.

The Board recognizes that the contents of its report are largely of a critical nature. The report highlights in detail faults or deficiencies in equipment and procedures that the Board has identified. This is the nature of a review board report.

It is important, however, to view the criticisms in this report in a broader context. The Apollo spacecraft system is not without shortcomings, but it is the only system of its type ever built and successfully demonstrated. It has flown to the Moon five times and landed twice. The tank which failed, the design of which is criticized in this report, is one of a series which had thousands of hours of successful operation in space prior to Apollo 13.

While the team of designers, engineers, and technicians that build and operate the Apollo spacecraft also has shortcomings, the accomplishments speak for themselves. By hardheaded self-criticism and continued dedication, this team can maintain this nation's preeminence in space.

PART 2. ASSESSMENT OF ACCIDENT

FAILURE OF OXYGEN TANK NO. 2

1. Findings

- a. The Apollo 13 mission was aborted as the direct result of the rapid loss of oxygen from oxygen tank no. 2 in the SM, followed by a gradual loss of oxygen from tank no. 1, and a resulting loss of power from the oxygen-fed fuel cells.
- b. There is no evidence of any forces external to oxygen tank no. 2 during the flight which might have caused its failure.
- c. Oxygen tank no. 2 contained materials, including Teflon and aluminum, which if ignited will burn in supercritical oxygen.
- d. Oxygen tank no. 2 contained potential ignition sources: electrical wiring, unsealed electric motors, and rotating aluminum fans.
- e. During the special detanking of oxygen tank no. 2 following the countdown demonstration test (CDDT) at KSC, the thermostatic switches on the heaters were required to open while powered by 65 V dc in order to protect the heaters from overheating. The switches were only rated at 30 V dc and have been shown to weld closed at the higher voltage.
- f. Data indicate that in flight the tank heaters located in oxygen tanks no. 1 and no. 2 operated normally prior to the accident, and they were not on at the time of the accident.
- g. The electrical circuit for the quantity probe would generate only about 7 millijoules in the event of a short circuit and the temperature sensor wires less than 3 millijoules per second.
- h. Telemetry data immediately prior to the accident indicate electrical disturbances of a character which would be caused by short circuits accompanied by electrical arcs in the fan motor or its leads in oxygen tank no. 2.
- i. The pressure and temperature within oxygen tank no. 2 rose abnormally during the 1-1/2 minutes immediately prior to the accident.

Determinations

- (1) The cause of the failure of oxygen tank no. 2 was combustion within the tank.
- (2) Analysis showed that the electrical energy flowing into the tank could not account for the observed increases in pressure and temperature.
- (3) The heater, temperature sensor, and quantity probe did not initiate the accident sequence.
- (4) The cause of the combustion was most probably the ignition of Teflon wire insulation on the fan motor wires, caused by electric arcs in this wiring.
- (5) The protective thermostatic switches on the heaters in oxygen tank no. 2 failed closed during the initial portion of the first special detanking operation. This subjected the wiring in the vicinity of the heaters to very high temperatures which have been subsequently shown to severely degrade Teflon insulation.
- (6) The telemetered data indicated electrical arcs of sufficient energy to ignite the Teflon insulation, as verified by subsequent tests. These tests also verified that the 1-ampere fuses on the fan motors would pass sufficient energy to ignite the insulation by the mechanism of an electric arc.
- (7) The combustion of Teflon wire insulation alone could release sufficient heat to account for the observed increases in tank pressure and local temperature, and could locally overheat and fail the tank or its associated tubing. The possibility of such failure at the top of the tank was demonstrated by subsequent tests.
- (8) The rate of flame propagation along Teflon-insulated wires as measured in subsequent tests is consistent with the indicated rates of pressure rise within the tank.

SECONDARY EFFECTS OF TANK FAILURE

2. Findings

- a. Failure of the tank was accompanied by several events including:

A "bang" as heard by the crew.

Spacecraft motion as felt by the crew and as measured by the attitude control system and the accelerometers in the command module (CM).

Momentary loss of telemetry.

Closing of several valves by shock loading.

Loss of integrity of the oxygen tank no. 1 system.

Slight temperature increases in bay 4 and adjacent sectors of the SM.

Loss of the panel covering bay 4 of the SM, as observed and photographed by the crew.

Displacement of the fuel cells as photographed by the crew.

Damage to the high-gain antenna as photographed by the crew.

- b. The panel covering of bay 4 could be blown off by pressurization of the bay. About 25 psi of uniform pressure in bay 4 is required to blow off the panel.
- c. The various bays and sectors of the SM are interconnected with open passages so that all would be pressurized if any one were supplied with a pressurant at a relatively slow rate.
- d. The CM attachments would be failed by an average pressure of about 10 psi on the CM heat shield and this would separate the CM from the SM.

Determinations

- (1) Failure of the oxygen tank no. 2 caused a rapid local pressurization of bay 4 of the SM by the high-pressure oxygen that escaped from the tank. This pressure pulse may have blown off the panel covering bay 4. This possibility was substantiated by a series of special tests.
- (2) The pressure pulse from a tank failure might have been augmented by combustion of Mylar or Kapton insulation or both when subjected to a stream of oxygen and hot particles emerging from the top of the tank, as demonstrated in subsequent tests.

- (3) Combustion or vaporization of the Mylar or Kapton might account for the discoloration of the SM engine nozzle as observed and photographed by the crew.
- (4) Photographs of the SM by the crew did not establish the condition of the oxygen tank no. 2.
- (5) The high-gain antenna damage probably resulted from striking by the panel, or a portion thereof, as it left the SM.
- (6) The loss of pressure on oxygen tank no. 1 and the subsequent loss of power resulted from the tank no. 2 failure.
- (7) Telemetry, although good, is insufficient to pin down the exact nature, sequence, and location of each event of the accident in detail.
- (8) The telemetry data, crew testimony, photographs, and special tests and analyses already completed are sufficient to understand the problem and to proceed with corrective actions.

OXYGEN TANK NO. 2 DESIGN

3. Findings

- a. The cryogenic oxygen storage tanks contained a combination of oxidizer, combustible material, and potential ignition sources.
- b. Supercritical oxygen was used to minimize the weight, volume, and fluid-handling problems of the oxygen supply system.
- c. The heaters, fans, and tank instrumentation are used in the measurement and management of the oxygen supply.

Determinations

- (1) The storage of supercritical oxygen was appropriate for the Apollo system.
- (2) Heaters are required to maintain tank pressure as the oxygen supply is used.
- (3) Fans were used to prevent excessive pressure drops due to stratification, to mix the oxygen to improve accuracy of

quantity measurements, and to insure adequate heater input at low densities and high oxygen utilization rates. The need for oxygen stirring on future flights requires further investigation.

- (4) The amount of material in the tank which could be ignited and burned in the given environment could have been reduced significantly.
- (5) The potential ignition sources constituted an undue hazard when considered in the light of the particular tank design with its assembly difficulties.
- (6) NASA, the prime contractor, and the supplier of the tank were not fully aware of the extent of this hazard.
- (7) Examination of the high-pressure oxygen system in the service module following the Apollo 204 fire, which directed attention to the danger of fire in a pure oxygen environment, failed to recognize the deficiencies of the tank.

PREFLIGHT DAMAGE TO TANK WIRING

4. Findings

- a. The oxygen tank no. 2 heater assembly contained two thermostatic switches designed to protect the heaters from overheating.
- b. The thermostatic switches were designed to open and interrupt the heater current at $80^{\circ} \pm 10^{\circ}$ F.
- c. The heaters are operated on 28 V dc in flight and at NR.
- d. The heaters are operated on 65 V ac at Beech Aircraft Corporation and 65 V dc at the Kennedy Space Center. These higher voltages are used to accelerate tank pressurization.
- e. The thermostatic switches were rated at 7 amps at 30 V dc. While they would carry this current at 65 V dc in a closed position, they would fail if they started to open to interrupt this load.
- f. Neither qualification nor acceptance testing of the heater assemblies or the tanks required thermostatic switch opening to be checked at 65 V dc. The only test of switch opening

was a continuity check at Beech in which the switch was cycled open and closed in an oven.

- g. The thermostatic switches had never operated in flight because this would only happen if the oxygen supply in a tank were depleted to nearly zero.
- h. The thermostatic switches had never operated on the ground under load because the heaters had only been used with a relatively full tank which kept the switches cool and closed.
- i. During the CDDT, the oxygen tank no. 2 would not detank in a normal manner. On March 27 and 28, a special detanking procedure was followed which subjected the heater to about 8 hours of continuous operation until the tanks were nearly depleted of oxygen.
- j. A second special detanking of shorter duration followed on March 30, 1970.
- k. The oxygen tanks had not been qualification tested for the conditions encountered in this procedure. However, specified allowable heater voltages and currents were not exceeded.
- l. The recorded internal tank temperature went off-scale high early in the special detanking. The thermostatic switches would normally open at this point but the electrical records show no thermostatic switch operation. These indications were not detected at the time.
- m. The oxygen tank heater controls at KSC contained ammeters which would have indicated thermostatic switch operation.

Determinations

- (1) During the special detanking of March 27 and 28 at KSC, when the heaters in oxygen tank no. 2 were left on for an extended period, the thermostatic switches started to open while powered by 65 V dc and were probably welded shut.
- (2) Failure of the thermostatic switches to open could have been detected at KSC if switch operation had been checked by observing heater current readings on the oxygen tank heater control panel. Although it was not recognized at the time, the tank temperature readings indicated that the heaters had reached their temperature limit and switch opening should have been expected.

- (3) The fact that the switches were not rated to open at 65 V dc was not detected by NASA, NR, or Beech in their reviews of documentation or in qualification and acceptance testing.
- (4) The failed switches resulted in severe overheating. Subsequent tests showed that heater assembly temperatures could have reached about 1000° F.
- (5) The high temperatures severely damaged the Teflon insulation on the wiring in the vicinity of the heater assembly and set the stage for subsequent short circuiting. As shown in subsequent tests, this damage could range from cracking to total oxidation and disappearance of the insulation.
- (6) During and following the special detanking, the oxygen tank no. 2 was in a hazardous condition whenever it contained oxygen and was electrically energized.

PART 3. SUPPORTING CONSIDERATIONS

DESIGN, MANUFACTURING, AND TEST

5. Finding

The pressure vessel of the supercritical oxygen tank is constructed of Inconel 718, and is moderately stressed at normal operating pressure.

Determination

From a structural viewpoint, the supercritical oxygen pressure vessel is quite adequately designed, employing a tough material well chosen for this application. The stress analysis and the results of the qualification burst test program confirm the ability of the tank to exhibit adequate performance in its intended application.

6. Findings

- a. The oxygen tank design includes two unsealed electric fan motors immersed in supercritical oxygen.
- b. Fan motors of this design have a test history of failure during acceptance test which includes phase-to-phase and phase-to-ground faults.
- c. The fan motor stator windings are constructed with Teflon-coated, ceramic-insulated, number 36 AWG wire. Full phase-to-phase and phase-to-ground insulation is not used in the motor design.
- d. The motor case is largely aluminum.

Determinations

- (1) The stator winding insulation is brittle and easily fractured during manufacture of the stator coils.
- (2) The use of these motors in supercritical oxygen was a questionable practice.

7. Findings

- a. The cryogenic oxygen storage tanks contained materials that could be ignited and which will burn under the conditions

prevailing within the tank, including Teflon, aluminum, solder, and Drilube 822.

- b. The tank contained electrical wiring exposed to the super-critical oxygen. The wiring was insulated with Teflon.
- c. Some wiring was in close proximity to heater elements and to the rotating fan.
- d. The design was such that the assembly of the equipment was essentially "blind" and not amenable to inspection after completion.
- e. Teflon insulation of the electrical wiring inside the cryogenic oxygen storage tanks of the SM was exposed to relatively sharp metal edges of tank inner parts during manufacturing assembly operations.
- f. Portions of this wiring remained unsupported in the tank on completion of assembly.

Determinations

- (1) The tank contained a hazardous combination of materials and potential ignition sources.
- (2) Scraping of the electrical wiring insulation against metal inner parts of the tank constituted a substantial cumulative hazard during assembly, handling, test, checkout, and operational use.
- (3) "Cold flow" of the Teflon insulation, when pressed against metal corners within the tank for an extended period of time, could result in an eventual degradation of insulation protection.
- (4) The externally applied electrical tests (500-volt Hi-pot) could not reveal the extent of such possible insulation damage but could only indicate that the relative positions of the wires at the time of the tests were such that the separation or insulation would withstand the 500-volt potential without electrical breakdown.
- (5) The design was such that it was difficult to insure against these hazards.
- (6) There is no evidence that the wiring was damaged during manufacturing.

9. Findings

- a. Dimensioning of the short Teflon and Inconel tube segments of the cryogenic oxygen storage tank fill line was such that looseness to the point of incomplete connection was possible in the event of worst-case tolerance buildup.
- b. The insertion of these segments into the top of the tank quantity probe assembly at the point of its final closure and welding was difficult to achieve.
- c. Probing with a hand tool was used in manufacturing to compensate for limited visibility of the tube segment positions.

Determination

It was possible for a tank to have been assembled with a set of relatively loose fill tube parts that could go undetected in final inspection and be subsequently displaced.

10. Findings

- a. The Apollo spacecraft system contains numerous pressure vessels, many of which carry oxidants, plus related valves and other plumbing.
- b. Investigation of potential hazards associated with these other systems was not complete at the time of the report, but is being pursued by the Manned Spacecraft Center.
- c. One piece of equipment, the fuel cell oxygen supply valve module, has been identified as containing a similar combination of high-pressure oxygen, Teflon, and electrical wiring as in the oxygen tank no. 2. The wiring is unfused and is routed through a 10-amp circuit breaker.

Determination

The fuel cell oxygen supply valve module has been identified as potentially hazardous.

11. Findings

- a. In the normal sequence of cryogenic oxygen storage tank integration and checkout, each tank undergoes shipping, assembly into an oxygen shelf for a service module, factory transportation to facilitate shelf assembly test, and then integration of shelf assembly to the SM.

- b. The SM undergoes factory transportation, air shipment to KSC, and subsequent ground transportation and handling.

Determination

There were environments during the normal sequence of operations subsequent to the final acceptance tests at Beech that could cause a loose-fitting set of fill tube parts to become displaced.

12. Findings

- a. At North American Rockwell, Downey, California, in the attempt to remove the oxygen shelf assembly from SM 106, a bolt restraining the inner edge of the shelf was not removed.
- b. Attempts to lift the shelf with the bolt in place broke the lifting fixture, thereby jarring the oxygen tanks and valves.
- c. The oxygen shelf assembly incorporating S/N XTAA0008 in the tank no. 2 position, which had been shaken during removal from SM 106, was installed in SM 109 one month later.
- d. An analysis, shelf inspection, and a partial retest emphasizing electrical continuity of internal wiring were accomplished before reinstallation.

Determinations

- (1) Displacement of fill tube parts could have occurred, during the "shelf drop" incident at the prime contractor's plant, without detection.
- (2) Other damage to the tank may have occurred from the jolt, but special tests and analyses indicate that this is unlikely.
- (3) The "shelf drop" incident was not brought to the attention of project officials during subsequent detanking difficulties at KSC.

13. Finding

Detanking, expulsion of liquid oxygen out the fill line of the oxygen tank by warm gas pressure applied through the vent line, was a regular activity at Beech Aircraft, Boulder, Colorado, in emptying a portion of the oxygen used in end-item acceptance tests.

Determination

The latter stages of the detanking operation on oxygen tank no. 2 conducted at Beech on February 3, 1967, were similar to the standard procedure followed at KSC during the CDDT.

14. Findings

- a. The attempt to detank the cryogenic oxygen tanks at KSC after the CDDT by the standard procedures on March 23, 1970, was unsuccessful with regard to tank no. 2.
- b. A special detanking procedure was used to empty oxygen tank no. 2 after CDDT. This procedure involved continuous protracted heating with repeated cycles of pressurization to about 300 psi with warm gas followed by venting.
- c. It was employed both after CDDT and after a special test to verify that the tank could be filled.
- d. There is no indication from the heater voltage recording that the thermostatic switches functioned and cycled the heaters off and on during these special detanking procedures.
- e. At the completion of detanking following CDDT, the switches are only checked to see that they remain closed at -75° F as the tank is warmed up. They are not checked to verify that they will open at $+80^{\circ}$ F.
- f. Tests subsequent to the flight showed that the current associated with the KSC 65 V dc ground powering of the heaters would cause the thermostatic switch contacts to weld closed if they attempted to interrupt this current.
- g. A second test showed that without functioning thermostatic switches, temperatures in the 800° to 1000° F range would exist at locations on the heater tube assembly that were in close proximity with the motor wires. These temperatures are high enough to damage Teflon and melt solder.

Determinations

- (1) Oxygen tank no. 2 (XTA 0008) did not detank after CDDT in a manner comparable to its performance the last time it had contained liquid oxygen, i.e., in acceptance test at Beech.
- (2) Such evidence indicates that the tank had undergone some change of internal configuration during the intervening events of the previous 3 years.

- (3) The tank conditions during the special detanking procedures were outside all prior testing of Apollo CSM cryogenic oxygen storage tanks. Heater assembly temperatures measured in subsequent tests exceeded 1000° F.
- (4) Severe damage to the insulation of electrical wiring internal to the tank, as determined from subsequent tests, resulted from the special procedure.
- (5) Damage to the insulation, particularly on the long unsupported lengths of wiring, may also have occurred due to boiling associated with this procedure.
- (6) MSC, KSC, and NR personnel did not know that the thermostatic switches were not rated to open with 65 V dc GSE power applied.

15. Findings

- a. The change in detanking procedures on the cryogenic oxygen tank was made in accordance with the existing change control system during final launch preparations for Apollo 13.
- b. Launch operations personnel who made the change did not have a detailed understanding of the tank internal components, or the tank history. They made appropriate contacts before making the change.
- c. Communications, primarily by telephone, among MSC, KSC, NR, and Beech personnel during final launch preparations regarding the cryogenic oxygen system included incomplete and inaccurate information.
- d. The MSC Test Specification Criteria Document (TSCD) which was used by KSC in preparing detailed tank test procedures states the tank allowable heater voltage and current as 65 to 85 V dc and 9 to 17 amperes with no restrictions on time.

Determinations

- (1) NR and MSC personnel who prepared the TSCD did not know that the tank heater thermostatic switches would not protect the tank.
- (2) Launch operations personnel assumed the tank was protected from overheating by the switches.

- (3) Launch operations personnel at KSC stayed within the specified tank heater voltage and current limits during the detanking at KSC.

16. Findings

- a. After receipt of the Block II oxygen tank specifications from NR, which required the tank heater assembly to operate with 65 V dc GSE power only during tank pressurization, Beech Aircraft did not require their Block I thermostatic switch supplier to make a change in the switch to operate at the higher voltage.
- b. NR did not review the tank or heater to assure compatibility between the switch and the GSE.
- c. MSC did not review the tank or heater to assure compatibility between the switch and the GSE.
- d. No tests were specified by MSC, NR, or Beech to check this switch under load.

Determinations

- (1) NR and Beech specifications governing the powering and the thermostatic switch protection of the heater assemblies were inadequate.
- (2) The specifications governing the testing of the heater assemblies were inadequate.

17. Finding

The hazard associated with the long heater cycle during detanking was not given consideration in the decision to fly oxygen tank no. 2.

Determinations

- (1) MSC, KSC, and NR personnel did not know that the tank heater thermostatic switches did not protect the tank from overheating.
- (2) If the long period of continuous heater operation with failed thermostatic switches had been known, the tank would have been replaced.

18. Findings

- a. Management controls requiring detailed reviews and approvals of design, manufacturing processes, assembly procedures, test procedures, hardware acceptance, safety, reliability, and flight readiness are in effect for all Apollo hardware and operations.
- b. When the Apollo 13 cryogenic oxygen system was originally designed, the management controls were not defined in as great detail as they are now.

Determination

From review of documents and interviews, it appears that the management controls existing at that time were adhered to in the case of the cryogenic oxygen system incorporated in Apollo 13.

19. Finding

The only oxygen tank no. 2 anomaly during the final countdown was a small leak through the vent quick disconnect, which was corrected.

Determination

No indications of a potential inflight malfunction of the oxygen tank no. 2 were present during the launch countdown.

MISSION EVENTS THROUGH ACCIDENT

20. Findings

- a. The center engine of the S-II stage of the Saturn V launch vehicle prematurely shut down at 132 seconds due to large 16 hertz oscillations in thrust chamber pressure.
- b. Data indicated less than 0.1g vibration in the CM.

Determinations

- (1) Investigation of this S-II anomaly was not within the purview of the Board except insofar as it relates to the Apollo 13 accident.

- (2) The resulting oscillations or vibration of the space vehicle probably did not affect the oxygen tank.

21. Findings

- a. Fuel cell current increased between 46:40:05 and 46:40:08 indicating that oxygen tank no. 1 and tank no. 2 fans were turned on during this interval.
- b. The oxygen tank no. 2 quantity indicated off-scale high at 46:40:08.

Determinations

- (1) The oxygen tank no. 2 quantity probe short circuited at 46:40:08.
- (2) The short circuit could have been caused by either a completely loose fill tube part or a solder splash being carried by the moving fluid into contact with both elements of the probe capacitor.

22. Findings

- a. The crew acknowledged Mission Control's request to turn on the tank fans at 55:53:06.
- b. Spacecraft current increased by 1 ampere at 55:53:19.
- c. The oxygen tank no. 1 pressure decreased 8 psi at 55:53:19 due to normal destratification.

Determination

The fans in oxygen tank no. 1 were turned on and began rotating at 55:53:19.

23. Findings

- a. Spacecraft current increased by 1-1/2 amperes and ac bus 2 voltage decreased 0.6 volt at 55:53:20.
- b. Stabilization and Control System (SCS) gimbal command telemetry channels, which are sensitive indicators of electrical transients associated with switching on or off of certain spacecraft electrical loads, showed a negative initial transient during oxygen tank no. 2 fan turnon cycles and a positive initial transient during oxygen tank no. 2 fan turnoff

cycles during the Apollo 13 mission. A negative initial transient was measured in the SCS at 55:53:20.

- c. The oxygen tank no. 2 pressure decreased about 4 psi when the fans were turned on at 55:53:21.

Determinations

- (1) The fans in oxygen tank no. 2 were turned on at 55:53:20.
- (2) It cannot be determined whether or not they were rotating because the pressure decrease was too small to conclusively show destratification. It is likely that they were.

24. Finding

An 11.1-amp spike in fuel cell 3 current and a momentary 1.2-volt decrease were measured in ac bus 2 at 55:53:23.

Determinations

- (1) A short circuit occurred in the circuits of the fans in oxygen tank no. 2 which resulted in either blown fuses or opened wiring, and one fan ceased to function.
- (2) The short circuit probably dissipated an energy in excess of 10 joules which, as shown in subsequent tests, is more than sufficient to ignite Teflon wire insulation by means of an electric arc.

25. Findings

- a. A momentary 11-volt decrease in ac bus 2 voltage was measured at 55:53:38.
- b. A 22.9-amp spike in fuel cell 3 current was measured at 55:53:41.
- c. After the electrical transients, CM current and ac bus 2 voltage returned to the values indicated prior to the turn-on of the fans in oxygen tank no. 2.

Determination

Two short circuits occurred in the oxygen tank no. 2 fan circuits between 55:53:38 and 55:53:41 which resulted in either blown fuses or opened wiring, and the second fan ceased to function.

26. Finding

Oxygen tank no. 2 telemetry showed a pressure rise from 887 to 954 psia between 55:53:36 and 55:54:00. It then remained nearly constant for about 15 seconds and then rose again from 954 to 1008 psia, beginning at 55:54:15 and ending at 55:54:45.

Determinations

- (1) An abnormal pressure rise occurred in oxygen tank no. 2.
- (2) Since no other known energy source in the tank could produce this pressure buildup, it is concluded to have resulted from combustion initiated by the first short circuit which started a wire insulation fire in the tank.

27. Findings

- a. The pressure relief valve was designed to be fully open at about 1000 psi.
- b. Oxygen tank no. 2 telemetry showed a pressure drop from 1008 psia at 55:54:45 to 996 psia at 55:54:53, at which time telemetry data were lost.

Determination

This drop resulted from the normal operation of the pressure relief valve as verified in subsequent tests.

28. Findings

- a. At 55:54:29, when the pressure in oxygen tank no. 2 exceeded the master caution and warning trip level of 975 psia, the CM master alarm was inhibited by the fact that a warning of low hydrogen pressure was already in effect, and neither the crew nor Mission Control was alerted to the pressure rise.
- b. The master caution and warning system logic for the cryogenic system is such that an out-of-tolerance condition of one measurement which triggers a master alarm prevents another master alarm from being generated when any other parameter in the same system becomes out-of-tolerance.
- c. The low-pressure trip level of the master caution and warning system for the cryogenic storage system is only 1 psi below the specified lower limit of the pressure switch which controls the tank heaters. A small imbalance in hydrogen tank

pressures or a shift in transducer or switch calibration can cause the master caution and warning to be triggered preceding each heater cycle. This occurred several times on Apollo 13.

- d. A limit sense light indicating abnormal oxygen tank no. 2 pressure should have come on in Mission Control about 30 seconds before oxygen tank no. 2 failed. There is no way to ascertain that the light did, in fact, come on. If it did come on, Mission Control did not observe it.

Determinations

- (1) If the pressure switch setting and master caution and warning trip levels were separated by a greater pressure differential, there would be less likelihood of unnecessary master alarms.
- (2) With the present master caution and warning system, a spacecraft problem can go unnoticed because of the presence of a previous out-of-tolerance condition in the same subsystem.
- (3) Although a master alarm at 55:54:29 or observance of a limit sense light in Mission Control could have alerted the crew or Mission Control in sufficient time to detect the pressure rise in oxygen tank no. 2, no action could have been taken at that time to prevent the tank failure. However, the information could have been helpful to Mission Control and the crew in diagnosis of spacecraft malfunctions.
- (4) The limit sense system in Mission Control can be modified to constitute a more positive backup warning system.

29. Finding

Oxygen tank no. 2 telemetry showed a temperature rise of 38° F beginning at 55:54:31 sensed by a single sensor which measured local temperature. This sensor indicated off-scale low at 55:54:53.

Determinations

- (1) An abnormal and sudden temperature rise occurred in oxygen tank no. 2 at approximately 55:54:31.
- (2) The temperature was a local value which rose when combustion had progressed to the vicinity of the sensor.
- (3) The temperature sensor failed at 55:54:53.

30. Finding

Oxygen tank no. 2 telemetry indicated the following changes:
(1) quantity decreased from off-scale high to off-scale low in 2 seconds at 55:54:30, (2) quantity increased to 75.3 percent at 55:54:32, and (3) quantity was off-scale high at 55:54:51 and later became erratic.

Determinations

- (1) Oxygen tank no. 2 quantity data between 55:54:32 and 55:54:50 may represent valid measurements.
- (2) Immediately preceding and following this time period, the indications were caused by electrical faults.

31. Findings

- a. At about 55:54:53, or about half a second before telemetry loss, the body-mounted linear accelerometers in the command module, which are sampled at 100 times per second, began indicating spacecraft motions. These disturbances were erratic, but reached peak values of 1.17g, 0.65g, and 0.65g in the X, Y, and Z directions, respectively, about 13 milliseconds before data loss.
- b. The body-mounted roll, pitch, and yaw rate gyros showed low-level activity for 1/4 second beginning at 55:54:53.220.
- c. The integrating accelerometers indicated that a velocity increment of approximately 0.5 fps was imparted to the spacecraft between 55:54:53 and 55:54:55.
- d. Doppler tracking data measured an incremental velocity component of 0.26 fps along a line from the Earth to the spacecraft at approximately 55:54:55.
- e. The crew heard a loud "bang" at about this time.
- f. Telemetry data were lost between approximately 55:54:53 and 55:54:55 and the spacecraft switched from the narrow-beam antenna to the wide-beam antenna.
- g. Crew observations and photographs showed the bay 4 panel to be missing and the high-gain antenna to be damaged.

Determinations

- (1) The spacecraft was subjected to abnormal forces at approximately 55:54:53. These disturbances were reactions resulting from failure and venting of the oxygen tank no. 2 system and subsequent separation and ejection of the bay 4 panel.
- (2) The high-gain antenna was damaged either by the panel or a section thereof from bay 4 at the time of panel separation.

32. Finding

Temperature sensors in bay 3, bay 4, and the central column of the SM indicated abnormal increases following reacquisition of data at 55:54:55.

Determination

Heating took place in the SM at approximately the time of panel separation.

33. Findings

- a. The telemetered nitrogen pressure in fuel cell 1 was off-scale low at reacquisition of data at 55:54:55.
- b. Fuel cell 1 continued to operate for about 3 minutes past this time.
- c. The wiring to the nitrogen sensor passes along the top of the shelf which supports the fuel cells immediately above the oxygen tanks.

Determinations

- (1) The nitrogen pressure sensor in fuel cell 1 or its wiring failed at the time of the accident.
- (2) The failure was probably caused by physical damage to the sensor wiring or shock.
- (3) This is the only known instrumentation failure outside the oxygen system at that time.

34. Finding

Oxygen tank no. 1 pressure decreased rapidly from 879 psia to 782 psia at approximately 55:54:54 and then began to decrease more slowly at 55:54:56.

Determination

A leak caused loss of oxygen from tank no. 1 beginning at approximately 55:54:54.

35. Findings

- a. Oxygen flow rates to fuel cells 1 and 3 decreased in a 5-second period beginning at 55:54:55, but sufficient volume existed in lines feeding the fuel cells to allow them to operate about 3 minutes after the oxygen supply valves were cut off.
- b. The crew reported at 55:57:44 that five valves in the reaction control system (RCS) were closed. The shock required to close the oxygen supply valves is of the same order of magnitude as the shock required to close the RCS valves.
- c. Fuel cells 1 and 3 failed at about 55:58.

Determination

The oxygen supply valves to fuel cells 1 and 3, and the five RCS valves, were probably closed by the shock of tank failure or panel ejection or both.

MISSION EVENTS AFTER ACCIDENT

36. Findings

- a. Since data presented to flight controllers in Mission Control are updated only once per second, the 1.8-second loss of data which occurred in Mission Control was not directly noticed. However, the Guidance Officer did note and report a "hardware restart" of the spacecraft computer. This was quickly followed by the crew's report of a problem.
- b. Immediately after the crew's report of a "bang" and a main bus B undervolt, all fuel cell output currents and all bus voltages were normal, and the cryogenic oxygen tank indications were as follows:

Oxygen tank no. 1: Pressure: Several hundred psi below
normal

Quantity: Normal

Temperature: Normal

Oxygen tank no. 2: Pressure: Off-scale low

Quantity: Off-scale high

Temperature: Off-scale high

- c. The nitrogen pressure in fuel cell 1 indicated zero, which was incompatible with the hydrogen and oxygen pressures in this fuel cell, which were normal. The nitrogen pressure is used to regulate the oxygen and hydrogen pressure, and hydrogen and oxygen pressures in the fuel cell would follow the nitrogen pressure.
- d. Neither the crew nor Mission Control was aware at the time that oxygen tank no. 2 pressure had risen abnormally just before the data loss.
- e. The flight controllers believed that a probable cause of these indications could have been a cryogenic storage system instrumentation failure, and began pursuing this line of investigation.

Determination

Under these conditions it was reasonable to suspect a cryogenic storage system instrumentation problem, and to attempt to verify the readings before taking any action. The fact that the oxygen tank no. 2 quantity measurement was known to have failed several hours earlier also contributed to the doubt about the credibility of the telemetered data.

37. Findings

- a. During the 3 minutes following data loss, neither the flight controllers nor the crew noticed the oxygen flows to fuel cells 1 and 3 were less than 0.1 lb/hr. These were unusually low readings for the current being drawn.
- b. Fuel cells 1 and 3 failed at about 3 minutes after the data loss.

- c. After the fuel cell failures, which resulted in dc main bus B failure and the undervoltage condition on dc main bus A, Mission Control diverted its prime concern from what was initially believed to be a cryogenic system instrumentation problem to the electrical power system.
- d. Near-zero oxygen flow to fuel cells 1 and 3 was noted after the main bus B failure, but this was consistent with no power output from the fuel cells.
- e. The flight controllers believed that the fuel cells could have been disconnected from the busses and directed the crew to connect fuel cell 1 to dc main bus A and fuel cell 3 to dc main bus B.
- f. The crew reported the fuel cells were configured as directed and that the talkback indicators confirmed this.

Determinations

- (1) Under these conditions it was logical for the flight controllers to attempt to regain power to the busses since the fuel cells might have been disconnected as a result of a short circuit in the electrical system. Telemetry does not indicate whether or not fuel cells are connected to busses, and the available data would not distinguish between a disconnected fuel cell and a failed one.
- (2) If the crew had been aware of the reactant valve closure, they could have opened them before the fuel cells were starved of oxygen. This would have simplified subsequent actions.

38. Finding

The fuel cell reactant valve talkback indicators in the spacecraft do not indicate closed unless both the hydrogen and oxygen valves are closed.

Determinations

- (1) If these talkbacks were designed so that either a hydrogen or oxygen valve closure would indicate "barberpole," the Apollo 13 crew could possibly have acted in time to delay the failure of fuel cells 1 and 3, although they would nevertheless have failed when oxygen tank no. 1 ceased to supply oxygen.

- (2) The ultimate outcome would not have been changed, but had the fuel cells not failed, Mission Control and the crew would not have had to contend with the failure of dc main bus B and ac bus 2 or attitude control problems while trying to evaluate the situation.

Reaction Control System

39. Findings

- a. The crew reported the talkback indicators for the helium isolation valves in the SM RCS quads B and D indicated closed shortly after the dc main bus B failure. The secondary fuel pressurization valves for quads A and C also were reported closed.
- b. The SM RCS quad D propellant tank pressures decreased until shortly after the crew was requested to confirm that the helium isolation valves were opened by the crew.
- c. During the 1-1/2-hour period following the accident, Mission Control noted that SM RCS quad C propellant was not being used, although numerous firing signals were being sent to it.
- d. Both the valve solenoids and the onboard indications of valve position of the propellant isolation valves for quad C are powered by dc main bus B.
- e. During the 1-1/2-hour period immediately following the accident, Mission Control advised the crew which SM RCS thrusters to power and which ones to unpower.

Determinations

- (1) The following valves were closed by shock at the time of the accident:

Helium isolation valves in quads B and D

Secondary fuel pressurization valves in quads A and C
- (2) The propellant isolation valves in quad C probably were closed by the same shock.
- (3) Mission Control correctly determined the status of the RCS system and properly advised the crew on how to regain automatic attitude control.

Management of Electrical System

40. Findings

- a. After fuel cell 1 failed, the total dc main bus A load was placed on fuel cell 2 and the voltage dropped to approximately 25 volts, causing a caution and warning indication and a master alarm.
- b. After determining the fuel cell 2 could not supply enough power to dc main bus A to maintain adequate voltage, the crew connected entry battery A to this bus as an emergency measure to increase the bus voltage to its normal operating value.
- c. Mission Control directed the crew to reduce the electrical load on dc main bus A by following the emergency powerdown checklist contained in the onboard Flight Data File.
- d. When the power requirements were sufficiently reduced so that the one remaining fuel cell could maintain adequate bus voltage, Mission Control directed the crew to take the entry battery off line.
- e. Mission Control then directed the crew to charge this battery in order to get as much energy back into it as possible, before the inevitable loss of the one functioning fuel cell.

Determinations

- (1) Emergency use of the entry battery helped prevent potential loss of dc main bus A, which could have led to loss of communications between spacecraft and ground and other vital CM functions.
- (2) Available emergency powerdown lists facilitated rapid reduction of loads on the fuel cell and batteries.

Attempts to Restore Oxygen Pressure

41. Findings

- a. After determining that the CM problems were not due to instrumentation malfunctions, and after temporarily securing a stable electrical system configuration, Mission Control sought to improve oxygen pressures by energizing the fan and heater circuits in both oxygen tanks.

- b. When these procedures failed to arrest the oxygen loss, Mission Control directed the crew to shut down fuel cells 1 and 3 by closing the hydrogen and oxygen flow valves.

Determinations

- (1) Under more normal conditions oxygen pressure might have been increased by turning on heaters and fans in the oxygen tanks; no other known actions had such a possibility.
- (2) There was a possibility that oxygen was leaking downstream of the valves; had this been true, closing of the valves might have preserved the remaining oxygen in oxygen tank no. 1.

Lunar Module Activation

42. Findings

- a. With imminent loss of oxygen from oxygen tanks no. 1 and no. 2, and failing electrical power in the CM, it was necessary to use the lunar module (LM) as a "lifeboat" for the return to Earth.
- b. Mission Control and the crew delayed LM activation until about 15 minutes before the SM oxygen supply was depleted.
- c. There were three different LM activation checklists contained in the Flight Data File for normal and contingency situations; however, none of these was appropriate for the existing situation. It was necessary to activate the LM as rapidly as possible to conserve LM consumables and CM reentry batteries to the maximum extent possible.
- d. Mission Control modified the normal LM activation checklist and referred the crew to specific pages and instructions. This bypassed unnecessary steps and reduced the activation time to less than an hour.
- e. The LM inertial platform was aligned during an onboard checklist procedure which manually transferred the CM alignment to the LM.

Determinations

- (1) Initiation of LM activation was not undertaken sooner because the crew was properly more concerned with attempts to conserve remaining SM oxygen.
- (2) Mission Control was able to make workable on-the-spot modifications to the checklists which sufficiently shortened the time normally required for powering up the LM.

43. Findings

- a. During the LM powerup and the CSM powerdown, there was a brief time interval during which Mission Control gave the crew directions which resulted in neither module having an active attitude control system.
- b. This caused some concern in Mission Control because of the possibility of the spacecraft drifting into inertial platform gimbal lock condition.
- c. The Command Module Pilot (CMP) stated that he was not concerned because he could have quickly reestablished direct manual attitude control if it became necessary.

Determination

This situation was not hazardous to the crew because had gimbal lock actually occurred, sufficient time was available to re-establish an attitude reference.

44. Findings

- a. LM flight controllers were on duty in Mission Control at the time of the accident in support of the scheduled crew entry into the LM.
- b. If the accident had occurred at some other time during the translunar coast phase, LM system specialists would not have been on duty, and it would have taken at least 30 minutes to get a fully manned team in Mission Control.

Determination

Although LM flight controllers were not required until more than an hour after the accident, it was beneficial for them to be present as the problem developed.

LM Consumables Management

45. Findings

- a. The LM was designed to support two men on a 2-day expedition to the lunar surface. Mission Control made major revisions in the use rate of water, oxygen, and electrical power to sustain three men for the 4-day return trip to the Earth.
- b. An emergency powerdown checklist was available in the Flight Data File on board the LM. Minor revisions were made to the list to reduce electrical energy requirements to about 20 percent of normal operational values with a corresponding reduction in usage of coolant loop water.
- c. Mission Control determined that this maximum powerdown could be delayed until after 80 hours ground elapsed time, allowing the LM primary guidance and navigation system to be kept powered up for the second abort maneuver.
- d. Mission Control developed contingency plans for further reduction of LM power for use in case an LM battery problem developed. Procedures for use of CM water in the LM also were developed for use if needed.
- e. Toward the end of the mission, sufficient consumable margins existed to allow usage rates to be increased above earlier planned levels. This was done.
- f. When the LM was jettisoned at 141:30 the approximate remaining margins were:

Electrical power	4-1/2 hours
Water	5-1/2 hours
Oxygen	124 hours

Determinations

- (1) Earlier contingency plans and available checklists were adequate to extend life support capability of the LM well beyond its normal intended capability.
- (2) Mission Control maintained the flexibility of being able to further increase the LM consumables margins.

Modification of LM Carbon Dioxide Removal System

46. Findings

- a. The lithium hydroxide (LiOH) cartridges, which remove water and carbon dioxide from the LM cabin atmosphere, would have become ineffective due to saturation at about 100 hours.
- b. Mission rules set maximum allowable carbon dioxide partial pressure at 7.5mm Hg. LiOH cartridges are normally changed before cabin atmosphere carbon dioxide partial pressure reaches this value.
- c. Manned Spacecraft Center engineers devised and checked out a procedure for using the CM LiOH cannisters to achieve carbon dioxide removal. Instructions were given on how to build a modified cartridge container using materials in the spacecraft.
- d. The crew made the modification at 93 hours, and carbon dioxide partial pressure in the LM dropped rapidly from 7.5mm Hg to 0.1mm Hg.
- e. Mission Control gave the crew further instructions for attaching additional cartridges in series with the first modification. After this addition, the carbon dioxide partial pressure remained below 2mm Hg for the remainder of the Earth-return trip.

Determination

The Manned Spacecraft Center succeeded in improvising and checking out a modification to the filter system which maintained carbon dioxide concentration well within safe tolerances.

LM Anomaly

47. Findings

- a. During the time interval between 97:13:53 and 97:13:55, LM descent battery current measurements on telemetry showed a rapid increase from values of no more than 3 amperes per battery to values in excess of 30 amperes per battery. The exact value in one battery cannot be determined because the measurement for battery 2 was off-scale high at 60 amperes.

- b. At about that time the Lunar Module Pilot (LMP) heard a "thump" from the vicinity of the LM descent stage.
- c. When the LMP looked out the LM right-hand window, he observed a venting of small particles from the general area where the LM descent batteries 1 and 2 are located. This venting continued for a few minutes.
- d. Prior to 97:13 the battery load-sharing among the four batteries had been equal, but immediately after the battery currents returned to nominal, batteries 1 and 2 supplied 9 of the 11 amperes total. By 97:23 the load-sharing had returned to equal.
- e. There was no electrical interface between the LM and the CSM at this time.
- f. An MSC investigation of the anomaly is in progress.

Determinations

- (1) An anomalous incident occurred in the LM electrical system at about 97:13:53 which appeared to be a short circuit.
- (2) The thump and the venting were related to this anomaly.
- (3) The apparent short circuit cleared itself.
- (4) This anomaly was not directly related to the CSM or to the accident.
- (5) This anomaly represents a potentially serious electrical problem.

CM Battery Recharging

48. Findings

- a. About one half of the electrical capacity of reentry battery A (20 of 40 amp-hours) was used during emergency conditions following the accident. A small part of the capacity of reentry battery B was used in checking out dc main bus B at 95 hours. The reduced charge remaining in the batteries limited the amount of time the CM could operate after separation from the LM.

- b. Extrapolation of LM electrical power use rates indicated a capacity in excess of that required for LM operation for the remainder of the flight.
- c. Mission Control worked out a procedure for using LM battery power to recharge CM batteries A and B. This procedure used the electrical umbilical between the LM and the CM which normally carried electrical energy from the CM to the LM. The procedure was nonstandard and was not included in checklists.
- d. The procedure was initiated at 112 hours and CM batteries A and B were fully recharged by 128 hours.

Determination

Although there is always some risk involved in using new, untested procedures, analysis in advance of use indicated no hazards were involved. The procedure worked very well to provide an extra margin of safety for the reentry operation.

Trajectory Changes For Safe Return to Earth

49. Findings

- a. After the accident, it became apparent that the lunar landing could not be accomplished and that the spacecraft trajectory must be altered for a return to Earth.
- b. At the time of the accident, the spacecraft trajectory was one which would have returned it to the vicinity of the Earth, but it would have been left in orbit about the Earth rather than reentering for a safe splashdown.
- c. To return the spacecraft to Earth, the following midcourse corrections were made:

A 38-fps correction at 61:30, using the LM descent propulsion system (DPS), required to return the spacecraft to the Earth.

An 81-fps burn at 79:28, after swinging past the Moon, using the DPS engine, to shift the landing point from the Indian Ocean to the Pacific and to shorten the return trip by 9 hours.

A 7.8-fps burn at 105:18 using the DPS engine to lower Earth perigee from 87 miles to 21 miles.

A 3.2-fps correction at 137:40 using LM RCS thrusters, to assure that the CM would reenter the Earth's atmosphere at the center of its corridor.

- d. All course corrections were executed with expected accuracy and the CM reentered the Earth's atmosphere at 142:40 to return the crew safely at 142:54, near the prime recovery ship.
- e. Without the CM guidance and navigation system, the crew could not navigate or compute return-to-Earth maneuver target parameters.

Determinations

- (1) This series of course corrections was logical and had the best chance of success because, as compared to other options, it avoided use of the damaged SM; it put the spacecraft on a trajectory, within a few hours after the accident, which had the best chance for a safe return to Earth; it placed splash-down where the best recovery forces were located; it shortened the flight time to increase safety margins in the use of electrical power and water; it conserved fuel for other course corrections which might have become necessary; and it kept open an option to further reduce the flight time.
- (2) Mission Control trajectory planning and maneuver targeting were essential for the safe return of the crew.

Entry Procedures and Checklists

50. Findings

- a. Preparation for reentry required nonstandard procedures because of the lack of SM oxygen and electrical power supplies.
- b. The SM RCS engines normally provide separation between the SM and the CM by continuing to fire after separation.
- c. Apollo 13 SM RCS engines could not continue to fire after separation because of the earlier failure of the fuel cells.
- d. The CM guidance and navigation system was powered down due to the accident. The LM guidance and navigation system had also been powered down to conserve electrical energy and water. A spacecraft inertial attitude reference had to be established prior to reentry.

- e. The reentry preparation time had to be extended in order to accomplish the additional steps required by the unusual situation.
- f. In order to conserve the CM batteries, LM jettison was delayed as long as practical. The LM batteries were used to supply part of the power necessary for CM activation.
- g. The procedures for accomplishing the final course correction and the reentry preparation were developed by operations support personnel under the direction of Mission Control.
- h. An initial set of procedures was defined within 12 hours after the accident. These were refined and modified during the following 2 days, and evaluated in simulators at MSC and KSC by members of the backup crew.
- i. The procedures were read to the crew about 24 hours prior to reentry, allowing the crew time to study and rehearse them.
- j. Trajectory evaluations of contingency conditions for LM and SM separation were conducted and documented prior to the mission by mission-planning personnel at MSC.
- k. Most of the steps taken were extracted from other procedures which had been developed, tested, and simulated earlier.

Determinations

- (1) The procedures developed worked well and generated no new hazards beyond those unavoidably inherent in using procedures which have not been carefully developed, simulated, and practiced over a long training period.
- (2) It is not practical to develop, simulate, and practice procedures for use in every possible contingency.

51. Findings

- a. During the reentry preparations, after SM jettison, there was a half-hour period of very poor communications with the CM due to the spacecraft being in a poor attitude with the LM present.
- b. This condition was not recognized by the crew or by Mission Control.

Determination

Some of the reentry preparations were unnecessarily prolonged by the poor communications, but since the reentry preparation timeline was not crowded, the delay was more of a nuisance than an additional hazard to the crew.

52. Findings

- a. The crew maneuvered the spacecraft to the wrong LM roll attitude in preparation for LM jettison. This attitude put the CM very close to gimbal lock which, had it occurred, would have lost the inertial attitude reference essential for an automatic guidance system control of reentry.
- b. If gimbal lock had occurred, a less accurate but adequate attitude reference could have been reestablished prior to reentry.

Determination

The most significant consequence of losing the attitude reference in this situation would have been the subsequent impact on the remaining reentry preparation timeline. In taking the time to reestablish this reference, less time would have been available to accomplish the rest of the necessary procedures. The occurrence of gimbal lock in itself would not have significantly increased the crew hazard.

PART 4. RECOMMENDATIONS

1. The cryogenic oxygen storage system in the service module should be modified to:

a. Remove from contact with the oxygen all wiring, and the unsealed motors, which can potentially short circuit and ignite adjacent materials; or otherwise insure against a catastrophic electrically induced fire in the tank.

b. Minimize the use of Teflon, aluminum, and other relatively combustible materials in the presence of the oxygen and potential ignition sources.

2. The modified cryogenic oxygen storage system should be subjected to a rigorous requalification program, including careful attention to potential operational problems.

3. The warning systems on board the Apollo spacecraft and in the Mission Control Center should be carefully reviewed and modified where appropriate, with specific attention to the following:

a. Increasing the differential between master alarm trip levels and expected normal operating ranges to avoid unnecessary alarms.

b. Changing the caution and warning system logic to prevent an out-of-limits alarm from blocking another alarm when a second quantity in the same subsystem goes out of limits.

c. Establishing a second level of limit sensing in Mission Control on critical quantities with a visual or audible alarm which cannot be easily overlooked.

d. Providing independent talkback indicators for each of the six fuel cell reactant valves plus a master alarm when any valve closes.

4. Consumables and emergency equipment in the LM and the CM should be reviewed to determine whether steps should be taken to enhance their potential for use in a "lifeboat" mode.

5. The Manned Spacecraft Center should complete the special tests and analyses now underway in order to understand more completely the details of the Apollo 13 accident. In addition, the lunar module power system anomalies should receive careful attention. Other NASA Centers should continue their support to MSC in the areas of analysis and test.

6. Whenever significant anomalies occur in critical subsystems during final preparation for launch, standard procedures should require a presentation of all prior anomalies on that particular piece of equipment, including those which have previously been corrected or explained. Furthermore, critical decisions involving the flightworthiness of subsystems should require the presence and full participation of an expert who is intimately familiar with the details of that subsystem.

7. NASA should conduct a thorough reexamination of all of its spacecraft, launch vehicle, and ground systems which contain high-density oxygen, or other strong oxidizers, to identify and evaluate potential combustion hazards in the light of information developed in this investigation.

8. NASA should conduct additional research on materials compatibility, ignition, and combustion in strong oxidizers at various g levels; and on the characteristics of supercritical fluids. Where appropriate, new NASA design standards should be developed.

9. The Manned Spacecraft Center should reassess all Apollo spacecraft subsystems, and the engineering organizations responsible for them at MSC and at its prime contractors, to insure adequate understanding and control of the engineering and manufacturing details of these subsystems at the subcontractor and vendor level. Where necessary, organizational elements should be strengthened and in-depth reviews conducted on selected subsystems with emphasis on soundness of design, quality of manufacturing, adequacy of test, and operational experience.

This page left blank intentionally.