

# RETROFITTING SCT/PPT EXCITATION SYSTEMS WITH DIGITAL CONTROL

John A. Estes, Jr., E<sup>2</sup> Power Systems, Inc.  
Richard C. Schaefer, Basler Electric Company

Increases in power demand continue to burden power suppliers. *Efficiency, reliability, improved control* and *uptime* are key words to describe power production needs in today's power starved industry.

Many operating power plants utilize excitation systems dating back to the 1960s and 1970s, using the original OEM-provided equipment. Such trade names as SCT/PPT, Alterrex, Magastat, Silver Stat, Regulux, Amplidyne, and PRX excitation systems represent a large majority of excitation systems that are either obsolete or difficult to maintain in operating power plants today. These tradename excitation systems are common on utility, industrial, and municipal steam and gas turbine generators.

Each of these obsolete excitation systems represented a unique control design that today can be upgraded to a modern digital control excitation system. New "digitally" controlled systems will streamline the unit startup, improve the generator response, provide better monitoring and protection to the generating system, and make the Operator's job easier.

This paper will review a specific excitation system retrofit of the SCT/PPT (Saturable Current Transformer/Power Potential Transformer) Static Excitation System and the various factors involving a rehabilitation project that includes new equipment, design interface, installation, and commissioning. A successful retrofit project begins with proper planning to ensure that the new installation meets the schedule and on-time commitment for power production.

## I. Introduction

The SCT/PPT excitation system, manufactured by the General Electric Company, was a popular excitation system design in the 1970s. It was used on new units, as well as being utilized as a retrofit on the older generating systems. These units were main field static exciter systems, popular on medium sized synchronous machines (5 – 250 MVA generators)



Figure 1: Main field-excited steam turbine generator

and applied on both gas and steam turbine generators (see Figure 1).

The SCT/PPT excitation system is a compound-type static exciter, which makes it ideal for handling very high short-time increases in generator loads, such as the starting of large motors or riding through single- or three-phase faults, even when the generator terminal voltage is virtually zero. Thus, these high inrush type loads actually boost the excitation levels, which helps reduce voltage dips and speed voltage recovery time.

The SCT/PPT excitation system uses both a generator stator voltage source (PPT) and a generator stator current source (SCT) as the power source for the main field. When the generator is off-line and not supplying current to a load, the excitation field current is supplied by the 3-phase, power potential transformer. When the generator is on-line and supplying current to the system load, a portion of the excitation field current is supplied by the three saturable current transformers. Since there is both a current source and a voltage source used in this compound-type excitation system, linear reactors are utilized to prevent the PPT from being shorted when the SCTs are saturated. These three magnetic components (PPT, SCTs and Linear Reactors) constitute the power magnetics for this compound-type excitation system, all of which have been

designed specifically for each generator to ensure the correct amount of excitation field current is available for all load conditions. This makes the SCT/PPT compound-type excitation system very desirable (see Figure 2).



Figure 2: SCTs and linear reactors located on the Generator Neutral Bus

Aging, obsolescence, and maintainability have become concerns as today's power starved economies dictate a need for reliable power. The SCT/PPT excitation system offers valuable assets to any power plant and system that is connected. Likewise, the power magnetics still demonstrate a very high degree of reliability in most systems today.

The voltage regulator portion of this compound-type excitation system, however, has become the "weakest link" with age and, hence, is the subject of this paper.

The ingredients of a successful retrofit are understanding the operation of the existing system, designing the interface of the new equipment to the existing system, and planning to meet the demands of power production.

## II. Existing Equipment

The SCT/PPT excitation system supplies excitation current to the generator field by utilizing power from the generator stator terminals and regulating this excitation current to maintain the desired terminal voltage. The block diagram for the SCT/PPT compound-type excitation system is illustrated in Figure 3. The static excitation system consists of

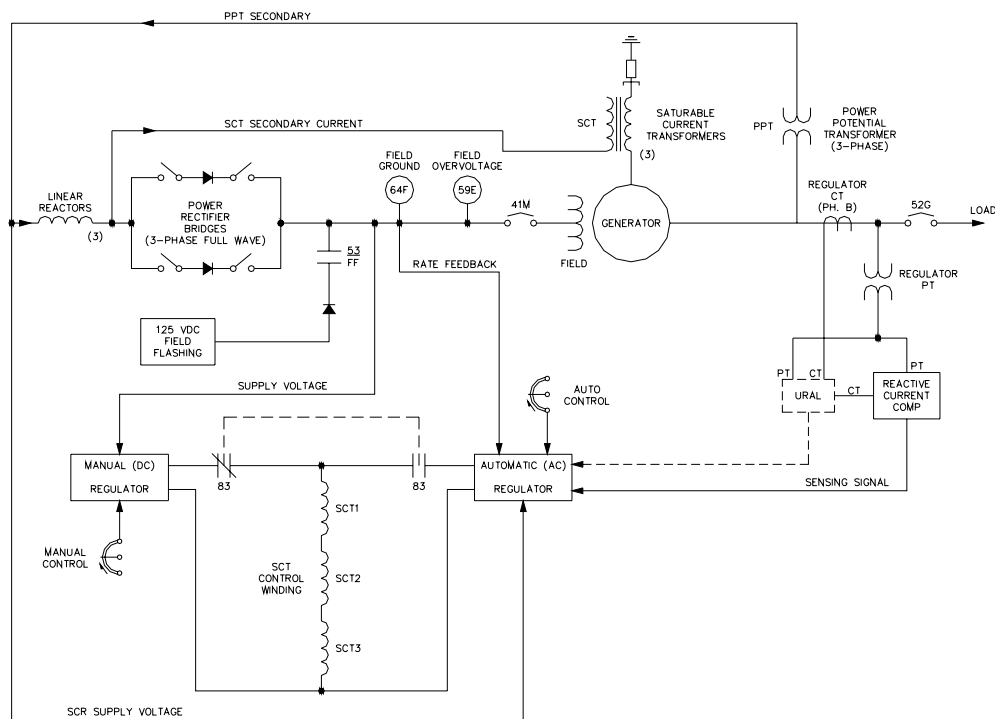

Figure 3: Block diagram of a typical SCT-PPT excitation system.

three basic components: the power magnetics (SCTs, PPT and linear reactors), the power rectifier bridge, and the voltage regulators (AC and DC). This static excitation system uses a combination of three linear reactors, three saturable current transformers, and a 3-phase, power potential transformer that are interconnected to provide an AC voltage into a power rectifier bridge(s). The output of the power rectifier bridge(s) supplies DC power directly to the main field of the generator.

The primary of the 3-phase, power potential transformer (PPT) is connected wye to the generator main leads. The secondaries of the saturable current transformers (SCTs) are delta connected and in parallel with a set of linear reactors connected in series with the delta connected secondary of the PPT. The combination of the power potential transformer (PPT) and the linear reactors is designed to provide all excitation current requirements at no-load conditions on the generator. The primaries of the three saturable current transformers (SCTs) are connected in series with the neutral leads of the generator. As the generator supplies more output armature current, more current is realized at the SCTs.

Under normal steady-state conditions, the phasor summation between the PPT/linear reactors and the SCTs provides the correct compensated voltage and current to the generator field for all loads at any power factor. But even during a three-phase short circuit on the generator terminals when the generator voltage collapses, the system will still supply the ceiling excitation current requirements to help the generator provide fault current output for coordinated relay tripping. In general, this compound-type static excitation system will ride through a fault, or a severe large motor starting condition, while other excitation systems, such as potential source, may collapse and trip off-line.

The AC output from the power magnetics is directed into the power rectifier bridge(s). (See Figure 4.) The 3-phase AC input is rectified to produce the DC current and voltage input to the generator field. The power rectifier bridge(s) is sized to handle the designed maximum outputs from the power magnetics of the SCT/PPT static excitation system, including the resultant currents from a three-phase fault on the generator terminals, and high field forcing required to meet motor starting requirements.

On most of the SCT/PPT systems, there are two or more parallel (redundant) full-wave diode bridges.



*Figure 4: Dual Power Rectifier Bridge Assembly located in the Generator Auxiliary Compartment*

To control and trim the output of the power magnetics during load changes, voltage adjustments, heating of the generator field, etc. there is a DC control winding embedded in each of the secondaries of the SCTs (see Figure 5). This DC control winding controls the magnetizing impedance of the SCTs and, thus, changes the saturation level of the SCT and the output into the main field rectifiers. An increase in DC current in the control winding will result in the SCTs saturating quicker and less output amperes available from the SCT secondaries. Hence, the excitation current to the generator field is reduced. Conversely, if the DC control current is lowered, the excitation current to the generator field is increased.

The output of either the Automatic (AC) Voltage Regulator or the Manual (DC) Voltage Regulator controls this DC control winding current. The voltage regulator utilized with the SCT/PPT excitation system is unique from most other regulators such that the magnitude at its output is opposite of the resultant voltage into the main field and power rectifier bridge. (See Figures 6 and 7.)

# Retrofitting SCT/PPT Excitation Systems with Digital Control

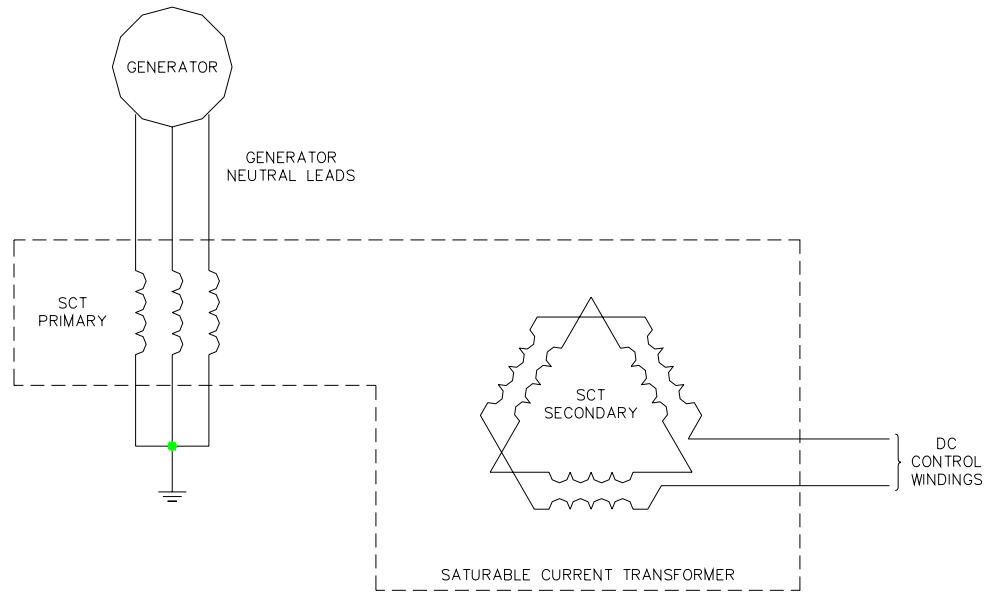

Figure 5: Applying DC amps through the control windings embedded in each of the SCT secondaries.



Figure 7: Voltage regulator and exciter field rheostat in the excitation switchgear lineup for a 40MVA steam turbine-generator

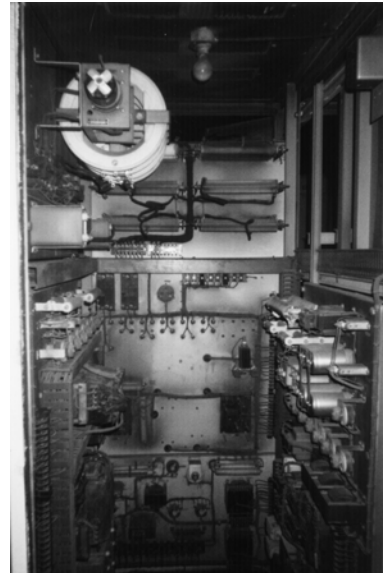

Figure 6: Automatic Voltage Regulator Gas Turbine-Generator unit

During normal steady-state operation, the SCT control winding current will remain essentially constant. If a disturbance occurs such that the terminal voltage should rise above normal, the output of the Automatic (AC) Voltage Regulator would rise to increase the amount of SCT control winding current. With the increase in control winding current, the DC saturation level to the SCT secondaries would be increased, providing less available output from the SCT secondaries and lowering the generator terminal voltage. If generator terminal voltage drops below the Operator's set point, the Automatic Voltage Regulator output would decrease the amount of SCT control winding current, allowing for an increase in the generator terminal voltage due to a decrease in the SCT core saturation.

Optional control accessories were normally resolved as part of each application. Most of these optional control accessories, such as the regulator auto tracking panel, the volts per Hertz regulator panel, the bus voltage matching panel, etc., were normally only utilized on the larger generators. For larger generators, the SCT/PPT excitation systems might also include optional "limit" panels, such as an Underexcited Reactive Ampere Limiter or a Maximum Excitation Limiter. When functioning properly, these limiters will provide a takeover signal only to the automatic (AC) Voltage Regulator to help prevent damage to the generator.

The output of the backup Manual (DC) Voltage Regulator also controlled the level of DC control winding current to the SCTs. But the Manual (DC) Voltage Regulator only controlled or maintained the level of excitation current to the generator field. It did not regulate the generator terminal voltage. On the SCT/PPT static excitation system, the level of generator field current can be set via a field rheostat setting or from the output of the DC voltage regulator.

The Manual (DC) Voltage Regulator was used only when the Automatic (AC) Voltage Regulator is out of service and being repaired.

For generator protection, the SCT/PPT excitation system usually included only a 59E Generator Field Overvoltage relay or module that would cause a transfer from the Automatic (AC) Voltage Regulator to Manual (DC) Voltage Regulator after a short time delay.

### Reliability Concerns

For most SCT/PPT excitation systems today, the power magnetics and the power rectifier bridge(s) continues to demonstrate high reliability. The major reasons for favoring a system retrofit are due to problems encountered by the old and obsolete voltage regulator that is no longer supportable.

Today, management at utility, industrials, and municipal power plants throughout the world has been directed to maintain or improve the existing levels of plant availability and to enhance the useful operating life of each generating system. To meet these needs, new digital systems have demonstrated that extended operating life can be achieved with increased unit flexibility, control and performance. Reasons and concerns noted for justification to retrofit a new static excitation or voltage regulator system include:

- The Automatic (AC) Voltage Regulator is out-of-service due to failure.
- The motor operated rheostats (see Figure 8) have developed worn shafts, cams, and open potentiometers that are no longer supportable.



Figure 8: Motor operated pot for AC and DC voltage regulator

- The limiters, such as the URAL, (see Figure 9) cannot be repaired or tuned due to the lack of renewable parts.



Figure 9: Underexcited Reactive Ampere Limit panel

- Reliability concerns and lack of in-house expertise.
- The turbine-generator requires the application of a new Power System Stabilizer.
- Increased need to extend the MVAR Capabilities of the generator via better protection and limiter circuitry.
- To eliminate the operating restrictions of the older equipment.
- Lack of flexibility by today's standards of control and protection.
- On most gas turbine applications, there is a lack of three-phase voltage sensing for balance loading between generator phases.
- Overexcitation limiting to prevent rotor overheating is not available with the existing system and generator protection is limited to generator field overvoltage or Volts/Hertz.
- Increased automatic control via Distributive Control system or PLC cannot be supported by the existing hardware.
- Manual control does not track the voltage regulator; hence transfer to manual control can cause a system upset.

- Systems now require better operating performance and better response time for improved transient stability.

At the time of design, the SCT/PPT excitation system was the state-of-the-art. But today, with new demands of plant control, Operator interface, voltage regulation, auto synchronization, and machine protection, the design criteria of the past have long placed compromises on today's operating system for reliability.

### III. Site Requirement

#### Determining the Retrofit Project

A retrofit of the SCT/PPT static excitation system can take one of two different paths:

1. Replacement of just the voltage regulator circuitry that controls the control winding of the saturable current transformer (SCT).
2. Complete static excitation system replacement, including the removal of all power magnetics (SCTs, PPT, and linear reactors), the power rectifier bridge(s), the generator field breaker (if supplied) and the voltage regulator system.

If the system has been properly maintained and the equipment is located in a clean, dry location, one can expect that the power magnetics and the power rectifier bridge(s) could be used for an extended time. For larger generators, the old generator field breaker could be a cause for concern, but retrofit of the breaker could be included with the changeout of the voltage regulator system if necessary.

A review of the maintenance data and the work orders completed on the SCT/PPT excitation system over the past years can help plant management personnel make a decision for which is the best solution, the voltage regulator replacement or the entire SCT/PPT excitation system.

Although both solutions are common, the more popular retrofit approach is to replace only the voltage regulator system and keep the existing power magnetics and power rectifier bridge(s) because of the lower replacement cost.

Addressing the Retrofit Requirements

Once the decision for a retrofit project is decided, the hardware and installation requirements need to be reviewed.

The Equipment

In digital control, standard features are now provided that previously were not attainable to achieve a higher level of control and generator performance. Most of the new digital control systems include:

1. Both Off-line and On-line over excitation current limiters. Off-line overexcitation prevents generator overvoltage when the circuit breaker is open by limiting the field current to low levels so to not exceed the volts/Hertz ratio of the generator.
2. Autotracking provides a means for safely transferring between the automatic voltage regulator and manual voltage regulator, and vice versa, without operator intervention.
3. Where previously the generator voltage needed to be manually adjusted to match the utility bus voltage for generator paralleling, voltage-matching feature can be software enabled that will automatically match the generator voltage to the bus voltage.
4. The old SCT/PPT voltage regulator required manual control for voltage startup. The new digital controller can be programmed for a specific time to have the generator voltage buildup to rated output without voltage overshoot under automatic voltage regulator control.
5. Some of the old analog voltage regulators were equipped with an under excitation limiter (URAL) that required painstaking effort to set potentiometers to achieve a circular characteristic for the generator reactive capability limit. Today, five points can be programmed based upon the generator capability curve and, within minutes, the UEL is ready for operation.
6. Where before, performance was limited to a half wave controlled rectifier bridge, the new digital controller offers a two quadrant control rectifier into the SCT control winding. The two-quadrant bridge provides both positive and negative control, which hastens generator response.
7. In prior systems, a loss of voltage sensing would inevitably result in a trip of the generator due to

overvoltage. In digital control, simply programming the internal protection for transfer to manual control in the event of loss of voltage sensing will provide continued reliable operation of the generator at critical periods of machine operation.

8. With a digital control system, the generating plant-operating mode can be selectable by the Operator for voltage regulation, VAR regulation, or Power Factor regulation.
9. Additional generator protection and annunciation is available in the digital voltage regulator systems including microprocessor watchdog timer, field overvoltage, field overcurrent, generator overvoltage, generator undervoltage, and rotor field temperature.
10. With the digital control system, redundant controllers can be provided that will transfer automatically to the backup digital controller in the event of a fault of the primary controller to keep the system operating (see Figure 10).



Figure 10: Dual digital control modules with automatic transfer and a local alarm/status LED

11. Less than one-second voltage response time to a system disturbance.
12. HMI (Human Machine Interface) panel for touch control and system monitoring / generator metering.
13. Volts per Hertz Limiter/Regulator.

14. Reactive droop compensation or line drop compensation.
15. Communication via RS-285 ports with commissioning software for setup and calibration of the excitation (ASCI) or RS-485 (Modbus™).

#### Project Considerations

The benefits of evaluating the entire generating system often extend beyond just the static excitation or voltage regulator system. When planning for the retrofit project, there are many other considerations that have to be taken into account to determine the extent of the project prior to the commitment to the issuance of any purchase orders:

1. Where will the new equipment be installed?
2. Will it be better to have the new excitation system “shipped-loose” on panels and install into the existing excitation switchgear or have it all included in a new enclosure?
3. How is this existing unit operated within the system? Is it connected to a Unit Step-Up Transformer or tied to a common bus with other generators?
4. What is the rating of the generator per the nameplate data? Is the generator design data available?
5. How will the unit be controlled, and where will it be controlled?
6. Is this a base loaded synchronous machine that dictates the need for redundant digital controllers?
7. To meet the commitments for power production, when does the equipment need to be ordered to allow for sufficient manufacturing lead times?
8. Often, a quick review of the generator protection will find the system lacking important functions that can ensure long life with additional monitoring. Additionally, as the machine continues to age, a closer examination of the synchronous machine protection can better safeguard the generator to ensure its longevity. Today’s multifunction relays can offer simple solutions to generator protection as well as realistic saving over the traditional electro mechanical relays.
9. Automatic synchronization should be another consideration to further automate the old processes to improve on-line synchronization time, accuracy, and repeatable performance. With new multifunction relays, synch check

- function provides a final check before synchronization to ensure that all systems are go!
10. During the installation, will in-house craft labor for the demolition and installation activities be used, with technical direction being provided by the equipment manufacturer? Or is a full “turnkey installation” project preferred?
  11. Who will handle the detailed design and associated documentation for the interface of the new equipment into the old system, in-house personnel or the equipment manufacturer?

#### Order Placement for the New Equipment

System options for this retrofit project have been reviewed and discussed. Now it is time for the final decisions.

Whether it is a detailed specification developed by an engineering firm or from the proposals received from the various equipment manufacturers, the end user must now move to place the order for the new digital voltage regulator system.

#### **IV. Installation – The Retrofit**

##### Site Visit

The success of any project is planning. One needs to know the scope of work, establish the milestones, and determine the strategies needed to complete the project on time and without surprises.

All of the tasks need to be determined for this project and will have to fit into a project timeline determined by the extent of the outage. This includes such tasks as *equipment manufacturing and delivery, interface design, ordering of installation materials, equipment delivery, demolition, installation, system testing, system startup and commissioning, training, and documentation*. For a successful project, a project schedule that outlines how the job will be performed is needed.

##### Initial Meeting

Communication is the key to any successful project, so an initial meeting is required to convey needs between the end user and the installer to make sure a complete understanding of the project and all expectations are understood. Items that need to be discussed include:



1. Schedules – To establish new equipment availability, demolition, and removal of the old equipment and installation of the new systems.
2. Project responsibilities and contacts are established.
3. Functional review of operation of the new upgraded SCT/PPT excitation system.
4. Review – Construction procedures and site safety issues.
5. Review – Location of the new equipment.
6. Review – All drawings (system elementaries, connections, and interconnections) of the existing system.
7. Review – Generator design data and curves.
8. Discuss – Whether to reuse the existing cable and conduit runs or to find the optimum direction for new cabling, conduit, and wire tray.
9. Review – Operator interface to the new upgraded excitation system, type of control, digital interface or contacts, alarms, and interface (see Figure 11).
10. Documentation – format for the final drawings.
11. Technical training schedule.
12. Coordination of work – With other vendors, e.g. turbine work.



*Figure 11: Existing generator controls and metering located at the BTG control panel are interfaced to the new digital control system*

Once a clear understanding is reached, the Project Schedule can be created.

During the initial site visit, the operation of the existing excitation system should be inspected. Known problems should be discussed with the end-user's operations and maintenance personnel. Unit data (Voltage, MV, MVAR, Amps, Field Volts, Field

Amps, SCT Control Amps, PPT secondary amps, SCT secondary amps, etc.) should be recorded over a varying operating range of the unit to help ensure that there are no unforeseen problems with the existing system.

#### Equipment Interface Design – Old to the New

To properly complete the interface of the new voltage regulator system, the designer must have a clear understanding and working knowledge of how this particular SCT/PPT excitation system works and how it was previously controlled and operated. The designer must look at the system configuration for this generating system in developing the interface design, such as unit connection to the bus, single or multiple machine, black start requirement, interconnection to the utility, etc.

Not all SCT/PPT excitation systems are controlled and operated the same. Startup and shutdown control sequence can vary drastically among the different types of gas turbine systems, and the control of the steam turbine systems. Startup control interface to a turbine, shutdown sequences, and the interface to the status of the generator breaker, the 86G lockout relay, and the generator field breaker need to be resolved.

Digital excitation systems can provide other avenues of control besides discrete contact. This can be accomplished via a RS 485 serial communication port for interfacing to existing control systems using protocols such as Modbus™ or DNP to control, meter, and obtain annunciation.

Engineering of the interface design requires development of an interconnection drawing for the new equipment to interface with the existing system. The design will vary based on whether the new equipment is supplied in a new enclosure or if it utilizes the existing cabinet and provides subpanels for mounting into those cabinets. The engineering interface drawing needs to provide a clear trail of the old and new interconnect for the hardware along with customer information specifics. Project information that needs to be supplied by the designer as part of the interface design should include:

1. Construction Drawing Package
  - a. System One-Line Drawings
  - b. System Interconnection Drawings
  - c. Electrical Construction Details

- i. Specification of all Installation Materials
  - ii. Bill of Material to include the installation materials, additional interface relays, control switches, indicating lights, meters, etc.
  - iii. Demolition details
  - iv. Installation details
  - v. Interface details
  - vi. Electrical layout
  - vii. Grounding details
  - viii. Cable and Conduit schedule
  - ix. Wire Schedule for all of the modification work
  - x. Equipment Interconnection Diagram
2. Connection and Elementary Detail Drawings of the new SCT/PPT excitation system
  3. Documentation Package in Project Book Format
    - a. Generator and Excitation System Data
    - b. All instruction manuals to apply to all of the equipment
    - c. New recommended operational procedures
    - d. Elementary and Construction Drawing Package
    - e. Software settings for the new excitation system
    - f. Spare and Renewal Parts information
    - g. Startup and Test Engineering Report

Technical Direction or Total Turnkey

Depending upon the end user, the actual installation may take one of two different directions.

The end user may choose to use his own craft labor to complete the on-site demolition and installation activities so that they can become familiar with the new equipment. In this case, technical direction is provided to the end user to address questions and facilitate the project while installation is taking place. Technical direction may involve a continued on site presence or just periodic checks of the installation.

Alternatively, the installer may provide all craft labor and assume total responsibility for the demolition as well as installation of the new equipment.

Demolition and Installation

A detailed demolition plan and wiring list as supplied with the *interface design* must be followed. Care must be taken so that only those devices and individual wires are removed from the existing system so that other systems, such as the generator control and protection circuitry, are not affected as a result of this retrofit (see Figure 12).

Upon completion of the demolition and removal of the hardware, installation can begin. Care should be

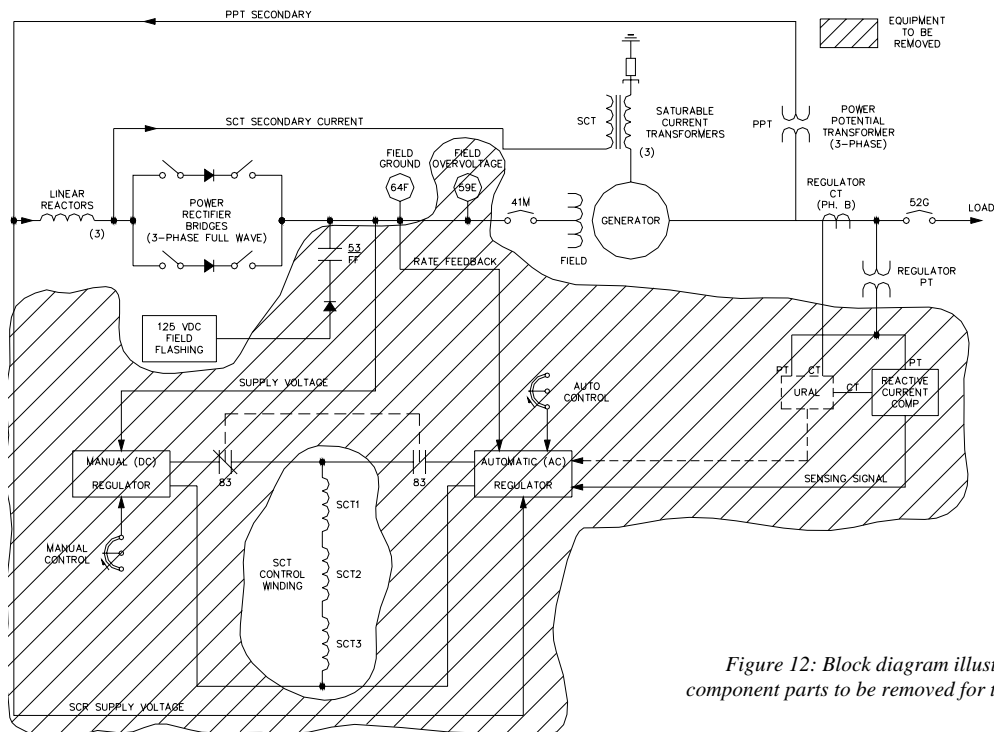

Figure 12: Block diagram illustrating component parts to be removed for the retrofit.

taken that all of the equipment and installation materials are available on site prior to the start of the installation (see Figure 13).



Figure 13: Retrofit of a new digital voltage regulator system into SCT-PPT excitation switchgear lineup

Project management tasks should be planned in advance. These tasks may include site safety, craft

labor supervision, and associated recordings and weekly progress reports to the end-user.

### System Testing

Checkout and testing of all new equipment, devices, and interconnection cables must be completed prior to energization of the new upgraded SCT/PPT excitation system. It is suggested that a “checklist” between the end user and the installer be developed so that, when the system testing is completed, there is a record for future use.

After the initial wire checks are completed, preliminary checks are made to the DC control circuits to verify control and sequencing of the equipment. A “dummy load” simulation with the new voltage regulator will provide confidence of a successful starting, prior to spinning the turbine, to avoid problems involving wiring errors.

Additionally, checks should be completed to the “old” integral components of the SCT/PPT excitation system prior to startup of the new system so that no surprises are encountered at startup. This work scope could be completed in parallel with the demolition and installation activities at the site. The checks may include:

1. SCT Control Winding circuitry
2. SCT Suppression Winding circuitry
3. Power rectifier bridge(s) and the associated hardware

With the system testing completed, all initial operating parameters of the new digital control system can be determined and reviewed with the end user. This would include the generator nameplate data, limiter thresholds, generator protection settings, traverse rates for set point changes, output contact status, alarms, etc. The new upgraded SCT/PPT excitation system is now ready for the unit running checks.

### Startup and Commissioning

This phase of the project includes the Off-Line (Full Speed No-Load) and On-Line setup and testing of the upgraded SCT/PPT excitation system. Equipment required for the setup and testing of the new upgraded system includes a laptop computer, a printer connected to the laptop, an oscilloscope, an oscillograph to monitor the generator field voltage and terminal voltage, a phase rotation meter, and some digital meters for troubleshooting (see Figure 14).



Figure 14: Start-up and commissioning of the new digital voltage regulator system is easier with all adjustments for setting the generator response, limits, protection, etc. at your fingertips via the serial port connection to your laptop computer.

After the unit startup sequence, generator softstart, and bus voltage matching operation is verified, the PID and limiter gain settings are tested to verify the performance expectations of the system. Step responses of 2-5% are typical parameters used to evaluate performance of the generator with the new excitation system. The oscillograph or the internal oscillography capability records the results of the step change performance to analyze the overall system response.

3. Human-Machine Interface (HMI) operation
4. System control
5. Alarms
6. Final software settings
7. Software interface for calibration
8. System Drawing review
9. Maintenance requirements

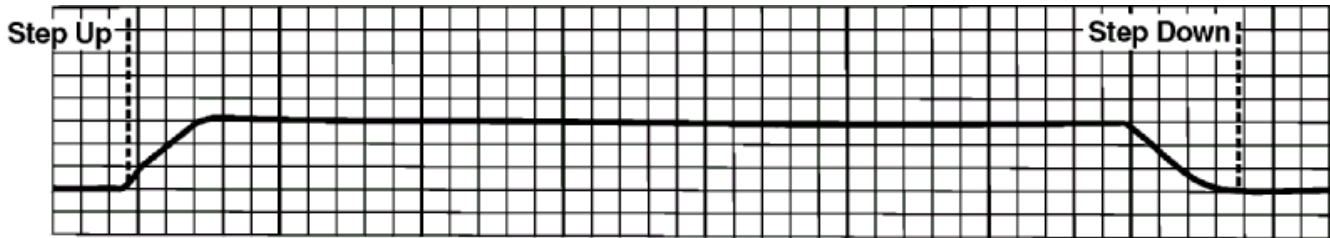

Figure 15: Illustrates 2% generator voltage step change and .5 second time response.

Similarly, the protection setting verification is often done with test sets to prove that the suggested values programmed into the new digital control system provide the desired trip and alarm characteristics. It is recommended that, as part of the commissioning process, this new upgraded excitation system be operated in all possible system configurations prior to the sign-off of the testing process by the end user. This would include:

1. Full-load operation on the unit to verify that control, gain, limiter performance, and reactive droop or line drop compensation is set up properly.
2. Verify single or multiple unit operation.
3. If this unit is intended for black-start, verify that the new digital control system will provide proper operation.

#### Technical Training

Training is an important requirement to ensure operators, technicians, and engineers are familiar with the hardware after personnel associated with the installation and startup depart.

The course outline should include:

1. Operation of the new excitation system (see Figure 16)
2. Protection and limiting functions

#### **V. Successful Installation**

The upgrade project was a success due to the planning that took place prior to the commencement of any of the on-site activities. Generator performance and protection has been enhanced due to the implementation of the new “digital” voltage regulator system. Reliability and maintenance issues have been address with this new system. The Unit Operators are happier because their jobs have been made easier due to the control and monitoring features provided.

The true test of a successful installation project depends entirely on the completeness of the final project documentation. The drawings and documentation should be complete and detailed such that someone other than the installer can come in and look through the project books and be able to readily troubleshoot the system.

“Refresher” training seminars can help keep this a successful installation for years to come.

# Retrofitting SCT/PPT Excitation Systems with Digital Control

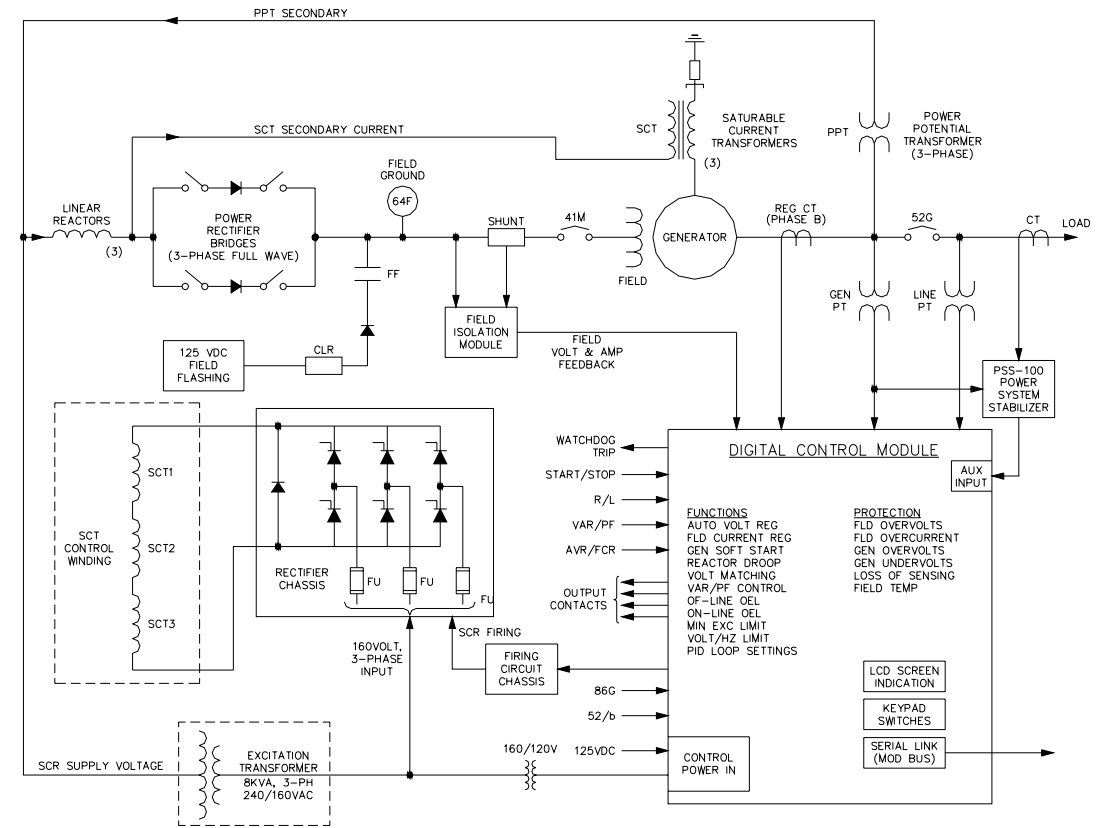

Figure 16: Block diagram of the new retrofit digital voltage regulator on a SCT-PPT static excitation system for a steam turbine-generator unit.

## Authors:

**John A. Estes, Jr.**  
**President**  
**E<sup>2</sup> Power Systems, Inc.**  
 7961 Shaffer Parkway, Unit #2  
 Littleton, CO 80127  
 TEL: 303-988-6659  
 FAX: 303-988-5714  
[Jestes@e2psi.com](mailto:Jestes@e2psi.com)

**Richard C. Schaefer**  
**Senior Application Specialist**  
**Basler Electric Company**  
 Route 143 Box 269  
 Highland, IL 62249  
 TEL: 618-654-2341 x757  
 FAX: 618-654-2351  
[RichSchaefer@Basler.com](mailto:RichSchaefer@Basler.com)