

# Models 2088, 2090P, and 2090F Pressure Transmitters



**ROSEMOUNT®**

FISHER-ROSEMOUNT™ Managing The Process Better.™



## Models 2088, 2090P, and 2090F Pressure Transmitters

### NOTICE

Read this manual before working with the product. For personal and system safety, and for optimum product performance, make sure you thoroughly understand the contents before installing, using, or maintaining this product.

Within the United States, Rosemount Inc. has two toll-free assistance numbers.

**Customer Central:** 1-800-999-9307 (7:00 a.m. to 7:00 p.m. CST)  
Technical support, quoting, and order-related questions.

**North American Response Center:** 1-800-654-7768 (24 hours a day – Includes Canada)  
Equipment service needs.

For equipment service or support needs outside the United States, contact your local Rosemount representative.

### CAUTION

The products described in this document are NOT designed for nuclear-qualified applications.

Using non-nuclear qualified products in applications that require nuclear-qualified hardware or products may cause inaccurate readings.

For information on Rosemount nuclear-qualified products, contact your local Rosemount Sales Representative.

*Rosemount Model 2088 Smart Pressure Transmitters may be protected by one or more U.S. and foreign patents issued and pending.*

*Rosemount Models 2088, 2090P, and 2090F Pressure Transmitters may be protected by one or more of the following U.S. Patent Nos.: 4,970,898 and 5,083,091. May depend on model. Other foreign patents issued and pending.*

*Rosemount, the Rosemount logotype, and SMART FAMILY are registered trademarks of Rosemount Inc. Coplanar is a trademark of Rosemount Inc.*

*HART is a registered trademark of the HART Communication Foundation.*

*Teflon is a registered trademark of E.I. du Pont de Nemours & Co.*

*Neobee is a registered trademark of Stepan Chemical Company.*

*Hastelloy is a registered trademark of Haynes International.*

*Tri-Clamp is a registered trademark of Tri-Clover Inc. of the Alfa-Laval Group.*

*PMC is a registered trademark of Paper Machine Company.*

*Viton is a registered trademark of E.I. Du Pont de Numours & Co.*

Cover Photo: 2088-006AB



Fisher-Rosemount satisfies all obligations coming from legislation to harmonize product requirements in the European Union.



# ROSEMOUNT®

FISHER-ROSEMOUNT™ Managing The Process Better.™

#### Rosemount Inc.

8200 Market Boulevard  
Chanhassen, MN 55317 USA  
Tel 1-800-999-9307  
Fax (612) 949-7001  
© 2000 Rosemount Inc.



[www.rosemount.com](http://www.rosemount.com)



# Table of Contents

## IMPORTANT

Procedures and instructions in this manual may require special precautions to ensure the safety of the personnel performing the operations. Information that raises potential safety issues is indicated by a warning symbol (⚠). **Refer to the safety messages, listed at the beginning of each section, before performing an operation preceded by this symbol.**

### SECTION 1 Introduction

Using this Manual .....	1-1
Safety Messages .....	1-1

### SECTION 2 Commissioning the Transmitter

Overview .....	2-1
Safety Messages .....	2-1
Warnings .....	2-1
Commission: On the Bench or In the Loop .....	2-2
Commissioning the Smart Transmitter .....	2-2
Set up the Smart Transmitter and the Communicator ....	2-2
Review Configuration Data .....	2-2
Review .....	2-3
Check Output .....	2-3
Process Variables .....	2-3
Basic Setup .....	2-3
Tag .....	2-3
Output Units .....	2-3
Rerange .....	2-3
Damping .....	2-4
Detailed Setup .....	2-5
Meter Setup .....	2-5
Burst Mode .....	2-5
Save, Recall, or Clone Configuration Data .....	2-6
Enable or Disable Local Span and Zero Buttons .....	2-6
Calibration .....	2-6
Calibration Overview .....	2-6
Sensor Trim .....	2-7
Output Trim .....	2-8
Diagnostics and Service .....	2-10
Multidrop Communication .....	2-10

### SECTION 3 Installation

Overview .....	3-1
Safety Messages .....	3-1
Warnings .....	3-1
General Considerations .....	3-3
Environmental Considerations .....	3-3
Temperature .....	3-3
Moisture and Corrosives .....	3-3
Hazardous Locations Installations .....	3-3

Mechanical Considerations	3-4
Mounting	3-4
Impulse Piping	3-5
Access Requirements	3-6
Model 2090P	3-7
Model 2090F	3-10
Electrical Considerations	3-11
Power Supply	3-11
Field Wiring	3-11
Failure Mode and Security Jumpers	3-12
Failure Mode	3-12
Jumper Locations	3-13
Transmitter Security	3-13
Zero and Span Adjustments	3-14
Rerange Procedure	3-14

**SECTION 4  
Maintenance and  
Troubleshooting**

Safety Messages	4-1
Troubleshooting	4-3
Downscale Alarm	4-4
Disassembly Procedure	4-5
Reassembly Procedure	4-5
Returning Rosemount Products and/or Materials	4-6

**SECTION 5  
Specifications and  
Reference Data**

Overview	5-1
Functional Specifications	5-1
Performance Specifications	5-3
Physical Specifications	5-5
Spare Parts	5-7
Ordering Information	5-10
Calibration	5-12
Tagging	5-12

**APPENDIX A  
LCD Meter**

LCD Meter	A-1
Safety Messages	A-1
Warnings	A-1
Custom Meter Configuration	A-2
Diagnostic Messages	A-3

**APPENDIX B  
Model 275 HART  
Communicator**

Overview	B-1
Safety Messages	B-1
Warnings	B-1
Connections and Hardware	B-4
Communicator Keys	B-5
Fast Key Sequences	B-7
Menus and Functions	B-7
Main Menu	B-7
Online Menu	B-8
Diagnostic Messages	B-9

---

<b>APPENDIX C</b> <b>Model 2088</b> <b>Low Power Option</b>	Overview .....	C-1
	Safety Messages .....	C-1
	Commissioning the Transmitter .....	C-1
	Installation .....	C-1
	Wiring .....	C-2
	Calibration .....	C-3
	Selector Switch .....	C-3
	Potentiometer Adjustment .....	C-4
	Setting the Zero .....	C-4
	Setting the Span .....	C-5
	Transient Protection Option .....	C-6
	Installation Procedures .....	C-6
	Transient Protection Board Installation .....	C-6
	Transient Protection Board Wiring .....	C-6
Specifications .....	C-7	
Functional Specifications .....	C-7	
Performance Specifications .....	C-7	
 <b>APPENDIX D</b> <b>Approval Drawings</b>	Overview .....	D-1
 <b>APPENDIX E</b> <b>European ATEX Directive</b> <b>Information</b>		





# Introduction

## USING THIS MANUAL

This manual provides information on commissioning, installing, and operating the Rosemount Models 2088, 2090P, and 2090F Pressure Transmitters. The manual is organized into the following sections:

### **Section 2: Commission the Transmitter**

provides information on commissioning and operating the transmitters, software functions, configuration parameters, and on-line variables.

### **Section 3: Installation**

provides mechanical and electrical installation instructions.

### **Section 4: Maintenance and Troubleshooting**

provides basic troubleshooting instructions, including sensing module checkout, disassembly, and reassembly procedures.

### **Section 5: Specifications and Reference Data**

provides functional specifications, physical specifications, performance specifications, for the Model 2088, 2090P, and 2090F Pressure Transmitters.

### **Appendix A: LCD Meter**

provides operating instructions for the optional LCD meter.

### **Appendix B: Model 275 HART Communicator**

contains a communicator overview, a HART Communicator menu tree for the Model 2088 Smart, and a table of HART Communicator fast key sequences. A table of diagnostic messages associated with this communicator is also included.

### **Appendix C: Low Power Option**

provides installation and calibration information specific to the Low Power Option.

### **Appendix D: Transient Protection Option**

provides installation, wiring, and specification information for the transient protection option

### **Appendix E: Approval Drawings**

provides the drawings necessary to install the transmitter in hazardous location.

### **Appendix F: European ATEX Directive Information**

provides information on European ATEX compliance.

## SAFETY MESSAGES

Procedures and instructions in this manual may require special precautions to ensure the safety of the personnel performing the operations. Information that raises potential safety issues is indicated by a warning symbol (⚠). Refer to the safety messages, listed at the beginning of each section, before performing an operation preceded by this symbol.



# Commissioning the Transmitter

## OVERVIEW

This section contains information on commissioning the transmitter. Commissioning involves reviewing configuration data, setting the 4 and 20 mA points, configuring the transmitter to recognize accessories such as an LCD meter, and testing the transmitter output.

## SAFETY MESSAGES

This section contains procedures that require connecting a communicator to the transmitter, or making connections in an explosive atmosphere. The following safety messages apply to all procedures throughout this section requiring cover removal and communicator or ammeter connection to the transmitter terminal block. Keep the following safety messages in mind whenever you perform an operation requiring cover removal or the connection of a communicator or other device to a measurement loop.

## Warnings

### WARNING

#### Explosions could result in death or serious injury:

- Do not remove the transmitter covers in explosive atmospheres when the circuit is alive.
- Before connecting a HART-based communicator in an explosive atmosphere, make sure the instruments in the loop are installed in accordance with intrinsically safe or non-incendive field wiring practices.
- Both transmitter covers must be fully engaged to meet explosion-proof requirements.

### WARNING

#### High voltage that may be present on leads could cause electrical shock:

- Avoid contact with leads and terminals.

## COMMISSION: ON THE BENCH OR IN THE LOOP

Commission the Model 2088 Transmitter before or after installation. It may be useful to commission the transmitter on the bench before installation to ensure proper operation, to familiarize yourself with transmitter functionality, and to avoid exposing the transmitter electronics to the plant environment.

Commissioning consists of :

- Reviewing configuration data
- Setting output units
- Setting the 4 and 20 mA points
- Configuring the transmitter for any non-standard accessories or functions, and testing the transmitter output

## COMMISSIONING THE SMART TRANSMITTER

### Set up the Smart Transmitter and the Communicator

 To configure the smart transmitter on the bench, connect the transmitter and the communicator as shown in Figure 2-1. To power the transmitter you will need a power supply capable of providing 10.5 to 36.0 V dc and a meter to measure output current. To enable communication, a resistance of at least 250 ohms must be present between the communicator loop connection and the power supply. You can connect the communicator leads at any termination point in the signal loop, but it is most convenient to connect them to the terminals labeled "COMM" on the terminal block.

After you connect the bench equipment as shown in Figure 2-1, turn on the communicator by pressing the ON/OFF key. The communicator will search for a HART-compatible device and will indicate when the connection is made. If the connection is not made, the communicator will indicate that no device was found.

FIGURE 2-1. Connecting a HART Communicator to a Transmitter Loop.

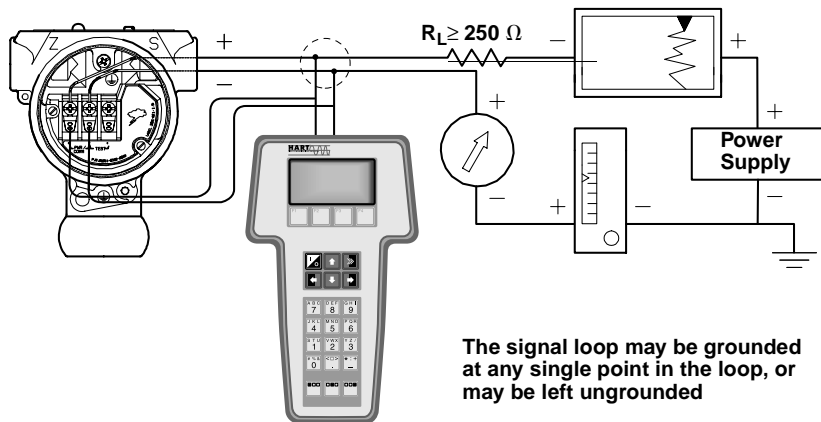

2088S-2088C02C

## REVIEW CONFIGURATION DATA

Review all of the factory-set configuration data to ensure that it reflects the needs of your application before operating the transmitter in an actual installation.

## Review

HART Fast Keys	1, 5
----------------	------

Review the transmitter configuration parameters set at the factory to ensure accuracy and compatibility with your particular application. After activating the review function, scroll through the data list to check each variable. Refer to “Basic Setup” in this section of the manual if a change to the transmitter configuration data is necessary.

## CHECK OUTPUT

Before performing other transmitter on-line operations, review the digital output parameters to ensure that the transmitter is operating properly and is configured to the appropriate process variables.

## Process Variables

HART Fast Keys	1, 1
----------------	------

The process variables for the Model 2088 provide the transmitter output, and are continuously updated. The *Process Variables* menu displays the following process variables:

- Pressure
- Percent Range
- Analog Output

## BASIC SETUP

From the *Basic Setup* menu you can configure the transmitter for certain basic variables. In many cases, all of these variables are pre-configured at the factory. Configuration may be required if your transmitter is not configured or if the configuration variables need revision.

## Tag

HART Fast Keys	1, 3, 1
----------------	---------

The *Tag* variable is the easiest way to identify and distinguish between transmitters in multi-transmitter environments. Use this variable to label transmitters electronically according to the requirements of your application. The tag you define is automatically displayed when a HART-based communicator establishes contact with the transmitter at power-up. The tag may be up to eight characters long and has no impact on the primary variable readings of the transmitter.

## Output Units

HART Fast Keys	1, 3, 2
----------------	---------

The *Unit* command sets the desired primary variable units. Set the transmitter output to one of the following engineering units:

- inH<sub>2</sub>O
- inHg
- ftH<sub>2</sub>O
- mmH<sub>2</sub>O
- psi
- bar
- mbar
- inH<sub>2</sub>O @ 4 °C
- g/cm<sup>2</sup>
- kg/cm<sup>2</sup>
- Pa
- kPa
- torr
- atm
- mmH<sub>2</sub>O @ 4 °C

### NOTE

After changing units, press SEND (F2) so the microprocessor will recalculate the associated variables (4–20 mA points, for example). The Model 2088 Smart recalculates all variables that depend on units. After the transmitter recalculates the variables, you may change any of the remaining parameters.

## Rerange

HART Fast Keys	1, 3, 3
----------------	---------



The *Range Values* command sets the 4 and 20 mA points (lower and upper range values). Setting the range values to the limits of expected readings maximizes transmitter performance; the transmitter is most accurate when operated within the expected pressure ranges for your application. In practice, you may reset the transmitter range values as often as necessary to reflect changing process conditions.

**NOTE**

Regardless of the range points, the Model 2088 Smart will measure and report all readings within the digital limits of the sensor. For example, if the 4 and 20 mA points are set to 0 and 10 inH<sub>2</sub>O, and the transmitter detects a pressure of 25 inH<sub>2</sub>O, it digitally outputs the 25 in H<sub>2</sub>O reading and a 250% percent of span reading. However, there may be up to ±5.0% error associated with output outside of the range points.

---

You may use one of three methods to rerange the transmitter. Each method is unique; examine all three closely before deciding which method to use.

**Method 1:Rerange Using the Communicator**

Reranging using only the communicator is the easiest and most popular way to rerange the transmitter. This method changes the values of the analog 4 and 20 mA points independently without a pressure input.

To rerange using only the communicator enter the fast-key sequence above, select *1 Keypad input*, and follow the on-line instructions. Or enter the values directly from the HOME screen.

**Method 2:Rerange Using the Communicator and a Pressure Source or Process Pressure**

Reranging using the communicator and a pressure source or process pressure is a way of reranging the transmitter when specific 4 and 20 mA points are not known. This method changes the values of the analog 4 and 20 mA points. When you set the 4 mA point the span is maintained; when you set the 20 mA point the span changes.

To rerange using the communicator and a pressure source or process pressure enter the fast-key sequence above, select *2 Apply values*, and follow the on-line instructions.

**Method 3:Rerange Using the Local Zero and Span Buttons and a Pressure Source or Process Pressure**

Reranging using the local zero and span adjustments and a pressure source is a way of reranging the transmitter when specific 4 and 20 mA points are not known and a communicator is not available. When you set the 4 mA point the span is maintained; when you set the 20 mA point the span changes.

**Damping**

HART Fast Keys	1. 3. 5
----------------	---------

The *Damping* command changes the response time of the transmitter to smooth variations in output readings caused by rapid changes in input. Determine the appropriate damping setting based on the necessary response time, signal stability, and other requirements of the loop dynamics of your system. The default damping value is 0.50 seconds and can be reset in fixed increments of 0.05, 0.10, 0.20, 0.40, 0.80, 1.60, 3.20, 6.40, 12.8, or 25.6 seconds.

## DETAILED SETUP

### Meter Setup

HART Fast Keys	1, 3, 6
----------------	---------

The *Meter Type* command allows you to configure the transmitter for use with an LCD meter. Transmitters shipped without meters are set to “NONE.” Change the meter settings as often as necessary to reflect changing process or application conditions. To change the meter settings, and thereby configure the transmitter to recognize the LCD meter, perform the following procedure.

1. Select 1 Device setup, 3 Basic setup, 6 Meter type to prepare to change the meter settings.
2. Select the appropriate variable configuration from the “Meter type” screen, and press enter.

---

#### NOTE

Selecting “None” from the meter type screen will disable the meter.

---

3. Select SEND to download the new meter configuration information to the transmitter.

For a more detailed description of the LCD meter features and diagnostic messages, refer to “LCD Meter” on page A-1.

### Burst Mode

HART Fast Keys	1, 4, 3, 3, 3
----------------	---------------

*Burst Mode* sets the transmitter to maintain digital contact with a Digital Control System that has custom software to support burst mode. When the Model 2088 Smart is configured for burst mode, it provides faster digital communication from the transmitter to the control system by eliminating the time required for the control system to request information from the transmitter.

*Burst mode* is compatible with use of the analog signal. Because HART® protocol features simultaneous digital and analog data transmission, the analog value can drive other equipment in the loop while the control system is receiving the digital information. Burst mode applies only to the transmission of dynamic data (pressure and temperature in engineering units, pressure in percent of range, and/or analog output in mA), and does not affect the way other transmitter data is accessed.

Access to information other than dynamic transmitter data is obtained through the normal poll/response method of HART communication. A HART-based communicator or the control system may request any of the information that is normally available while the transmitter is in burst mode. Between each message sent by the transmitter, a short pause allows the HART-based communicator or a control system to initiate a request. The transmitter will receive the request, process the response message, and then continue “bursting” the data approximately three times per second.

## Save, Recall, or Clone Configuration Data

HART Fast Keys	left arrow, 3 (note)
----------------	----------------------

Data that was entered off-line can be stored in the communicator memory and downloaded to other transmitters later. Data also can be copied from a transmitter in order to be sent to other transmitters in a process known as “cloning”. This is especially useful if you work with a large number of transmitters that require the same configuration data.

## Enable or Disable Local Span and Zero Buttons

HART Fast Keys	1, 4, 4, 1, 7
----------------	---------------

The *Local Keys* command allows you to enable or disable the local span and zero buttons. Disabling the local keys will prevent unauthorized reranging using the span and zero buttons, but will not prevent reranging using the communicator. To prevent all changes to the configuration data, use the transmitter security jumper (see “Transmitter Security” on page 3-13).

## CALIBRATION

Calibrating the transmitter increases the precision of your measurement system. You may use one or more of a number of trim functions when calibrating.

To understand the trim functions, it is necessary to understand that smart transmitters operate differently from analog transmitters. An important difference is that smart transmitters are factory-characterized; they are shipped with a standard sensor curve stored in the transmitter firmware. In operation, the transmitter uses this information to produce a process variable output, in engineering units, dependent on the sensor input. The trim functions allow you to make corrections to the factory-stored characterization curve by digitally altering the transmitter’s interpretation of the sensor input.

The trim functions should not be confused with the rerange functions. Although the rerange command matches a sensor input to a 4–20 mA output—as in conventional calibration—it does not affect the transmitter’s interpretation of the input.

## Calibration Overview

Complete calibration of the Model 2088 Smart Pressure Transmitter involves one or more of the following tasks:

### Configure the Analog Output Parameters

- Set Process Variable Units (Page 2-3)
- Rerange (Page 2-3)
- Set Output Type (Page 2-3)
- Set Damping (Page 2-4)

### Calibrate the Sensor

- Full Trim (Page 2-8)
- Zero Trim (Page 2-7)

### Calibrate the 4–20 mA Output

- Digital to Analog Trim (Page 2-9) or
- Scaled Digital to Analog Trim (Page 2-9)

Figure 2-2 illustrates the Model 2088 Smart Pressure Transmitter data flow. This data flow can be summarized in four major steps:

1. A change in pressure is measured by a change in the sensor output (Sensor Signal).
2. The sensor signal is converted to a digital format that can be understood by the microprocessor (Analog-to-Digital Signal Conversion).
3. Corrections are performed in the microprocessor to obtain a digital representation of the process input (Digital PV).
4. The Digital PV is converted to an analog value (Digital-to-Analog Signal Conversion).



FIGURE 2-2. Transmitter Data Flow with Calibration Options.

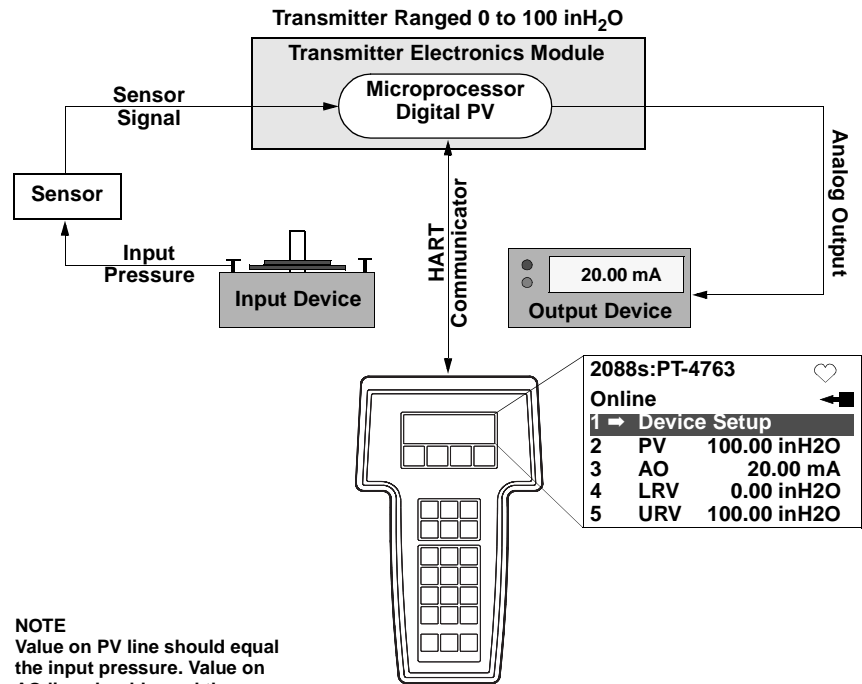

**NOTE**  
Value on PV line should equal the input pressure. Value on AO line should equal the output device reading.

1151-1151F05B

### Deciding Which Trim Procedure to Use

To decide which trim procedure to use, you must first determine whether the analog-to-digital section or the digital-to-analog section of the transmitter electronics is in need of calibration. To do so, refer to Figure 2-2 and perform the following procedure:

1. Connect a pressure source, a HART communicator, and a digital readout device to the transmitter.
2. Establish communication between the transmitter and the communicator.
3. Apply pressure (100 in H<sub>2</sub>O, for example).
4. Compare the applied pressure to the Process Variable (PV) line on the Communicator Online Menu. If the PV reading on the communicator does not match the applied pressure, and you are certain your test equipment is accurate, perform a sensor trim.
5. Compare the Analog Output (AO) line on the communicator online menu to the digital readout device. If the AO reading on the communicator does not match the digital readout device, and you are certain your test equipment is accurate, perform an output trim.

### Sensor Trim

You can trim the sensor using either the full trim or the zero trim function. The trim functions vary in complexity, and their use is application-dependent. Both alter the transmitter’s interpretation of the input signal.

#### Zero Trim

HART Fast Keys	1, 2, 3, 3, 1
----------------	---------------

A *Zero Trim* is a single-point adjustment. It is useful for compensating for mounting position effects, and is most effective when performed with the transmitter installed in its final mounting position. Since this correction maintains the slope of the characterization curve, it should not be used in place of a full trim over the full sensor range.

**NOTE**  
Use full trim on absolute transmitters; do not use zero trim.

To calibrate the sensor using the *Zero Trim* function, perform the following procedure.

1. Vent the transmitter and attach a communicator to the measurement loop.
2. From the communicator main menu select *1 Device setup, 2 Diagnostics and service, 3 Calibration, 3 Sensor trim, 1 Zero trim* to prepare to adjust the zero trim.

---

**NOTE**

The transmitter must be within 3% of true zero (zero based) in order to calibrate using the zero trim function.

---

3. Follow the commands provided by the communicator to complete the adjustment of the zero trim.

**Full Trim**

HART Fast Keys	1, 2, 3, 3
----------------	------------

A *Full Trim* is a two-point sensor calibration where two end-point pressures are applied, and all output is linearized between them. You should always adjust the low trim value first to establish the correct offset. Adjustment of the high trim value provides a slope correction to the characterization curve based on the low trim value. The factory-established characterization curve is not changed by this procedure. The trim values allow you to optimize performance over your specified measuring range at the calibration temperature.

To calibrate the sensor using the *Full Trim* function, perform the following procedure.

1. Assemble and power the entire calibration system including a transmitter, communicator, power supply, pressure input source, and readout device.

---

**NOTE**

Use a pressure input source that is at least three times more accurate than the transmitter, and allow the input pressure to stabilize for 10 seconds before entering any values.

---

2. From the communicator main menu select *1 Device setup, 2 Diagnostics and service, 3 Calibration, 3 Sensor trim, 2 Lower sensor trim* to prepare to adjust the lower trim point.

---

**NOTE**

Select pressure input values so that the low and high values are equal to or outside the 4 and 20 mA points. Do not attempt to obtain reverse output by reversing the high and low points. The transmitter allows approximately a 5% URL deviation from the characterized curve established at the factory.

---

3. Follow the commands provided by the communicator to complete the adjustment of the lower value.
4. Repeat the procedure for the upper value, replacing *2 Lower sensor trim* with *3 Upper sensor trim* in Step 2.

**Output Trim**

The *Output Trim* commands allow you to alter the transmitter's conversion of the input signal to a 4–20 mA output (see Figure 2-2 on page 2-7). Adjust the analog output signal at regular intervals to maintain precision. You can trim the transmitter output using either the digital to analog trim or the scaled digital to analog trim function.

**Digital to Analog Trim**

<b>HART Comm.</b>	1, 2, 3, 2, 1
<b>Model 268</b>	F4, F4, F3, F1, F1

To perform a *Digital-to-Analog Trim*, perform the following procedure.

1. From the HOME screen, select *1 Device setup, 2 Diag/Service, 3 Calibration, 4 D/A trim*. Select “OK” to after you set the control loop to manual.
2. Connect an accurate reference meter to the transmitter at the “Connect reference meter” prompt. To do so, connect the positive lead to the positive terminal and the negative lead to the test terminal in the transmitter terminal compartment, or shunt the transmitter power through the reference meter at some point.
3. Select “OK” after connecting the reference meter.
4. Select “OK” at the “Setting fld dev output to 4 mA” prompt.  
The transmitter outputs 4.00 mA.
5. Record the actual value from the reference meter, and enter it at the “Enter meter value” prompt.  
The communicator prompts you to verify whether or not the output value equals the value on the reference meter.
6. Select *1 Yes* if the reference meter value equals the transmitter output value, or *2 No* if it does not.  
If you select *1 Yes*, proceed to Step 7.  
If you select *2 No*, repeat Step 5.
7. Select “OK” at the “Setting fld dev output to 20 mA” prompt, and repeat Steps 5 and 6 until the reference meter value equals the transmitter output value.

Select “OK” after you return the control loop to automatic control.

**Scaled Digital to Analog Trim**

<b>HART Comm.</b>	1, 2, 3, 2, 2
<b>Model 268</b>	F4, F4, F3, F1, F2

The *Scaled Digital-to-Analog Trim* command matches the 4 and 20 mA points to a user-selectable reference scale other than 4 and 20 mA (1 to 5 volts if measuring across a 250 ohm load, or 0 to 100 percent if measuring from a DCS, for example). To perform a scaled D/A trim, connect an accurate reference meter to the transmitter and trim the output signal to scale as outlined in the Output Trim procedure.

**NOTE**

Use a precision resistor for optimum accuracy. If you add a resistor to the loop, ensure that the power supply is sufficient to power the transmitter to a 20 mA output with the additional loop resistance.

## DIAGNOSTICS AND SERVICE

### Test Device

HART Fast Keys	1, 2, 1, 1
----------------	------------

The *Test Device* command initiates a more extensive diagnostic routine than that performed continuously by the transmitter. The transmitter test routine can identify an electronics failure. If the transmitter test detects a problem, the communicator displays messages to indicate the source of the problem.

### Loop Test

HART Fast Keys	1, 2, 2
----------------	---------

The *Loop Test* command verifies the output of the transmitter, the integrity of the loop, and the operations of any recorders or similar devices installed in the loop. To initiate a loop test, perform the following procedure:

1. Connect a reference meter to the transmitter. To do so, either connect the meter to the test terminals on the transmitter terminal block, or shunt the power to the transmitter through the meter at some point in the loop.
2. From the HOME screen, Select *1 Device Setup, 2 Diagnostics and Service, 2 Loop Test*, to prepare to perform a loop test.
3. Select “OK” after you set the control loop to manual.  
The communicator displays the loop test menu.
4. Select a discreet milliamp level for the transmitter to output. At the “Choose analog output” prompt, select *1 4mA, 2 20mA*, or select *3 other* to manually input a value between 4 and 20 milliamps.
5. Check the current meter installed in the test loop to verify that it reads the value you commanded the transmitter to output. If the readings do not match, the transmitter requires an output trim or the current meter is malfunctioning.

After completing the test procedure, the display returns to the loop test screen and allows you to choose another output value.

## MULTIDROP COMMUNICATION

Multidropping transmitters refers to the connection of several transmitters to a single communications transmission line. Communication between the host and the transmitters takes place digitally with the analog output of the transmitters deactivated. Many of the Rosemount SMART FAMILY transmitters can be multidropped. With the HART communications protocol, up to 15 transmitters can be connected on a single twisted pair of wires or over leased phone lines. Note that Burst Mode Operation is not compatible with multidrop communications.

The application of a multidrop installation requires consideration of the update rate necessary from each transmitter, the combination of transmitter models, and the length of the transmission line. Multidrop installations are not recommended where intrinsic safety is a requirement. Communication with the transmitters can be accomplished with commercially available Bell 202 modems and a host implementing the HART protocol. Each transmitter is identified by a unique address (1-15) and responds to the commands defined in the HART protocol.

Figure 2-3 shows a typical multidrop network. This figure is not intended as an installation diagram. Contact Rosemount product support with specific requirements for multidrop applications.

FIGURE 2-3. Typical Multidrop Network.

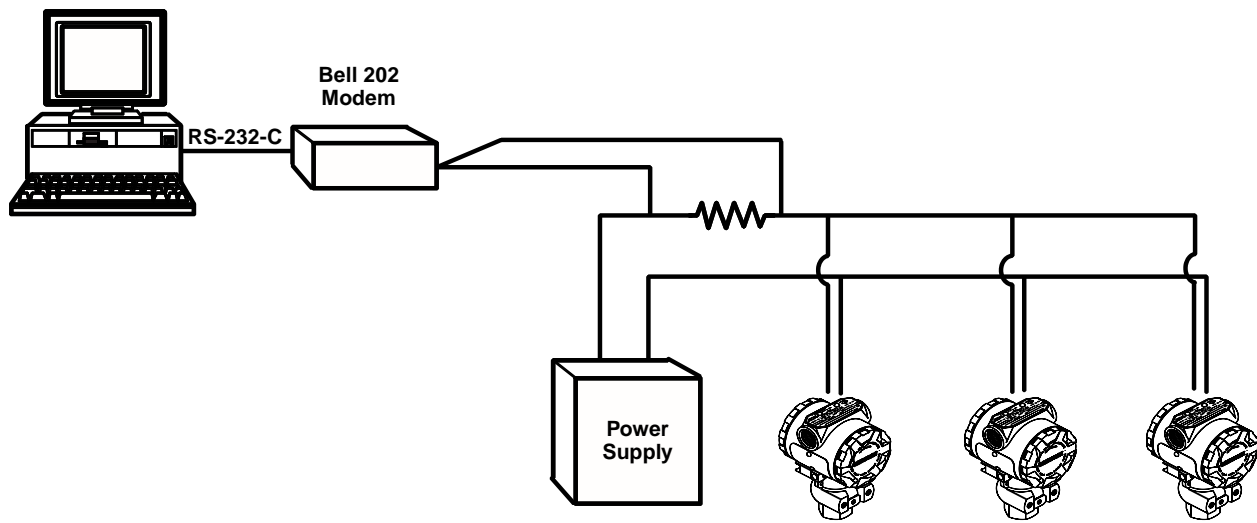

HART-based communicators can test, configure, and format a multidropped transmitter the same way as a transmitter in a standard point-to-point installation.

**NOTE**

The transmitter is set to address 0 at the factory, allowing it to operate in the standard point-to-point manner with a 4–20 mA output signal. To activate multidrop communication, you must change the transmitter address to a number from 1 to 15. This change deactivates the 4–20 mA analog output, locking it to 4 mA. It also disables the failure mode alarm signal, which is controlled by the upscale/downscale jumper position.

**Changing a Transmitter Address**

HART Fast Keys	1, 4, 3, 3, 1
----------------	---------------

To change the address of a multidropped transmitter, follow these fast key sequences. To activate multidrop communication, the transmitter address must be changed to a number from 1 to 15.

**Communicating with a Multidropped Transmitter**

HART Fast Keys	1, 4, 3, 3, 2
----------------	---------------

To communicate with a multidropped transmitter for the purpose of testing, configuring, or formatting.

**Polling a Multidropped Loop**

HART Fast Keys	Left Arrow, 4, 1, 1
----------------	---------------------

Polling a multidropped loop determines the model, address, and number of transmitters on the given loop.

**NOTE**

The Model 275 HART Communicator requires you to use the Utility Menu to perform an auto poll. This menu is available from the Main Menu of the HART Communicator. Press the left arrow to move from the Online Menu to the Main Menu. Press 4 from the Main Menu to access the Utility Menu.



# Installation

## OVERVIEW

This section is designed to guide you through a successful Models 2088, 2090F, or 2090P Transmitter installation. Starting with an installation flowchart, this section contains information on installation considerations and transmitter options. Dimensional drawings are also included in this section.

## SAFETY MESSAGES

Instructions and procedures in this section may require special precautions to ensure the safety of the personnel performing the operations. Information that raises potential safety issues is indicated by a warning symbol (⚠). Please refer to the following safety messages before performing an operation preceded by this symbol.

### Warnings

#### ⚠ WARNING

##### Explosions could result in death or serious injury:

- Do not remove the transmitter cover in explosive atmospheres when the circuit is alive.
- Before connecting a HART-based communicator in an explosive atmosphere, make sure the instruments in the loop are installed in accordance with intrinsically safe or non-incendive field wiring practices.
- Verify that the operating atmosphere of the transmitter is consistent with the appropriate hazardous locations certifications.
- Both transmitter covers must be fully engaged to meet explosion-proof requirements.

#### ⚠ WARNING

##### Failure to follow these installation guidelines could result in death or serious injury:

- Make sure only qualified personnel perform the installation.

#### ⚠ WARNING

##### High voltage that may be present on leads could cause electrical shock:

- Avoid contact with leads and terminals.

#### ⚠ WARNING

Use appropriately rated sanitary clamps and gaskets during installation. The maximum working pressure of the clamp and gasket must be greater than or equal to the working pressure range of the transmitter. Failure to use proper clamps and gaskets can cause process leaks and can result in death or serious injury.

FIGURE 3-1. Installation Flowchart.

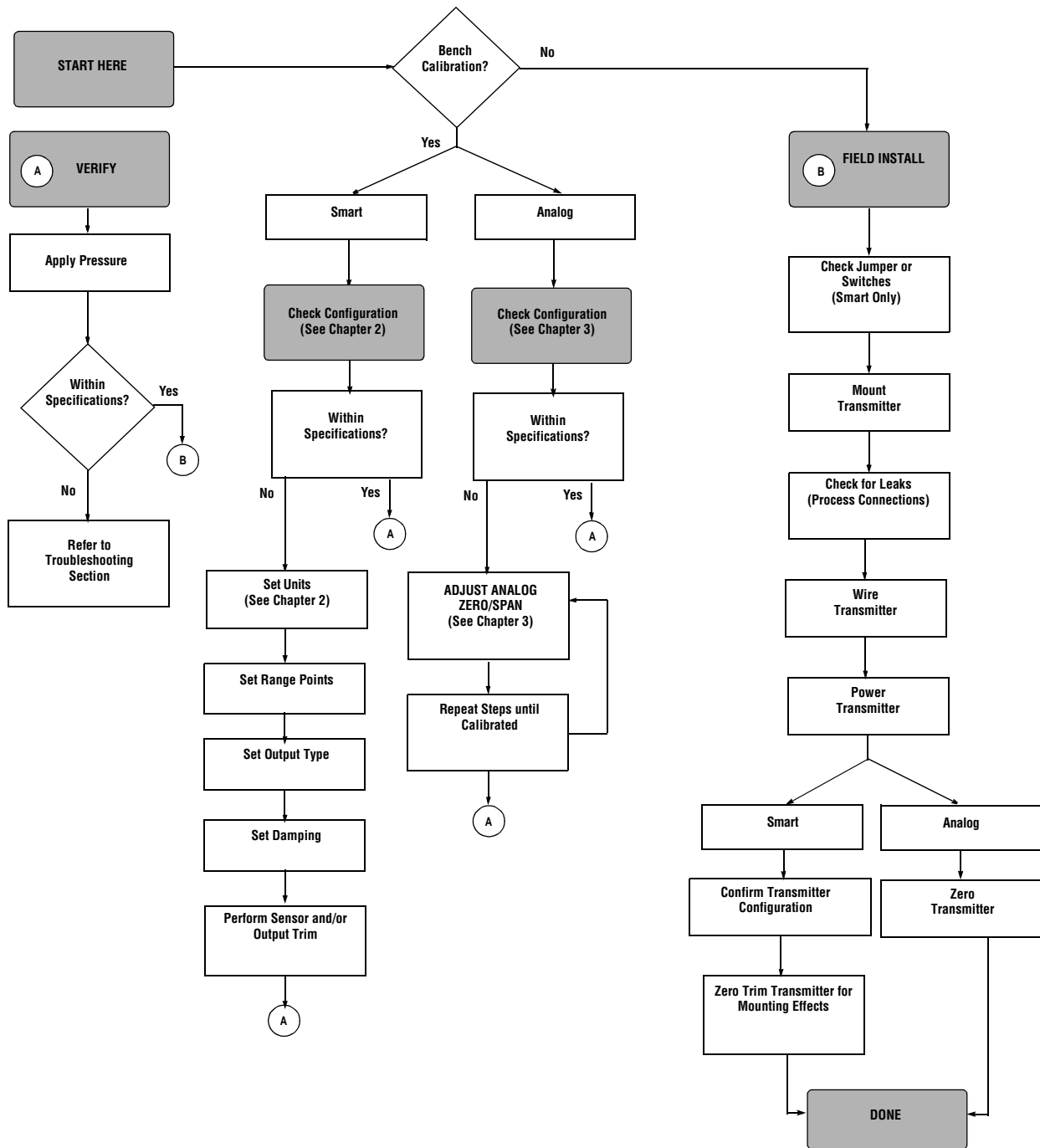



## GENERAL CONSIDERATIONS

The accuracy of the pressure measurement depends on proper installation of the transmitter and impulse piping. The piping between the process and transmitter must accurately transmit pressure to the transmitter. Mount the transmitter close to the process and use a minimum of impulse piping to achieve the best accuracy. Keep in mind, however, the need for convenient access, safety of personnel, practical field calibration, and a suitable transmitter environment. In general, install the transmitter to minimize vibration, shock, and temperature fluctuations.

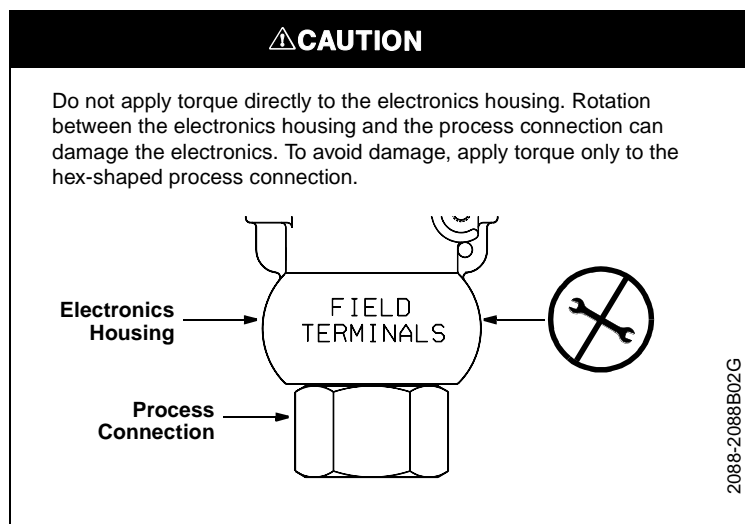

## ENVIRONMENTAL CONSIDERATIONS

### Temperature

Mount the transmitter in a manner that minimizes variations in ambient temperature.

### Moisture and Corrosives

The transmitter is designed to resist attack by moisture and corrosives. The electronics module is fully encapsulated and mounted in a compartment that is sealed from the power-side conduit entries. O-ring seals protect both compartments when the covers are installed.

In humid environments, it is possible for moisture to accumulate in the conduit lines and reach the terminal compartment of the transmitter housing. To prevent moisture from entering the terminal compartment, mount the transmitter at a high point in the conduit run, if possible. Also, remove the terminal compartment cover periodically and inspect the terminals for moisture and corrosion.

### Hazardous Locations Installations

Models 2088, 2090P, and 2090F transmitters are designed with explosion-proof electronics enclosures and circuitry that complies with intrinsic safety requirements and non-incendive operation. Individual transmitters are clearly tagged with approvals. Refer to Section 5: Specifications and Reference Data for a complete list of available approvals. To maintain certified ratings for installed transmitters, install with applicable installation codes and approval drawings.

#### NOTE

Once a device labeled with multiple approval types is installed, it should not be reinstalled using any other approval types. Permanently mark the approval label to distinguish it from unused approval types.

## MECHANICAL CONSIDERATIONS

### Mounting

#### Model 2088

The Model 2088 Smart Transmitter weighs approximately 2.44 lb (1,11 kg). The Model 2088 Analog Transmitter weighs approximately 1.9 lb (0,86 kg). In many cases, its compact size and light weight makes it possible to mount the Model 2088 directly to the impulse line without using an additional mounting bracket. When this is not desirable, mount directly to a wall, panel, or two-inch pipe using the optional mounting bracket (see Figure 3-2).

The Model 2088 also offers several process connections. Use your plant-approved thread sealant to ensure a leak-proof connection.

#### Model 2090P

The Model 2090P is designed to be mounted directly to the process pipe using a weld spud (see Figure 3-7). Mount the transmitter using an existing weld spud, or install a new one using the instructions on page 3-7.

#### Model 2090F

The Model 2090F is designed to be mounted directly to the process pipe using a standard sanitary fitting (see Figure 3-8). The transmitter is available with either a 1.5- or 2-inch Tri-Clamp® connection.

FIGURE 3-2. Transmitter Mounting Configurations with Optional Bracket.

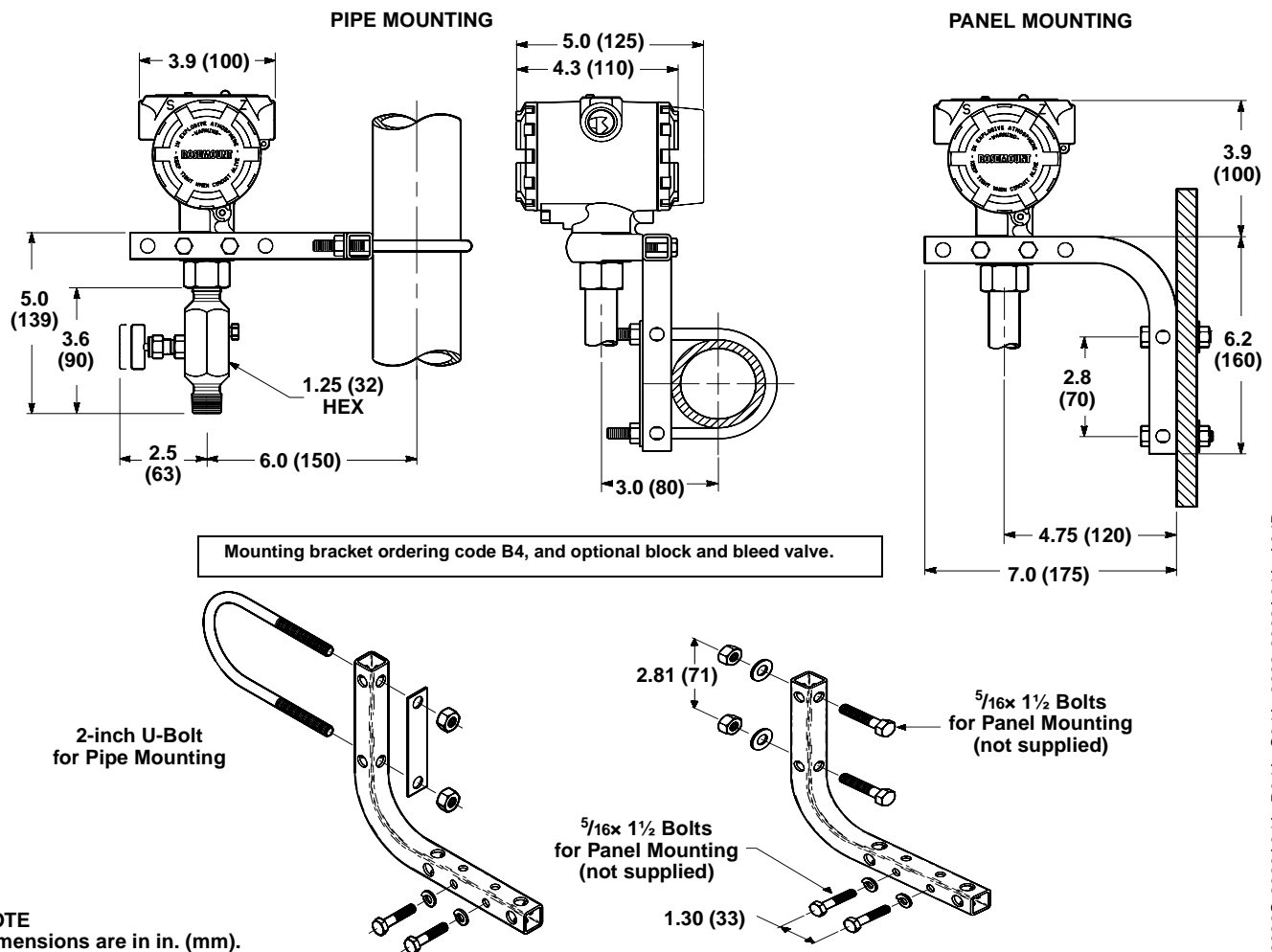

NOTE  
Dimensions are in in. (mm).

2088S-2088A04A, B04A, C04A; 2088-2088A04A, A04B

## Impulse Piping

Impulse piping configurations depend on specific measurement conditions. Use the following information and Figure 3-3 as a guideline when installing impulse piping.

**Liquids:** Make the line tap on the side of the pipe to prevent sediment deposits from plugging the impulse line or transmitter. Mount the transmitter level with or below the tap so gases vent into the process line.

**Gases:** Make line taps on either the top or the side of the process line. Mount the transmitter level with or above the line tap so liquids drain into the process line.

**Steam:** Make line taps in the side of the process line. Mount the transmitter below the line tap to ensure that the impulse line remains filled with condensate.

### NOTE

Installing a “T”-connection with a shut-off valve in the impulse line between the transmitter and the valve to the process line will allow you to vent the transmitter to atmosphere, thereby enabling calibration without removing the transmitter.

FIGURE 3-3. Transmitter Mounting Configurations for Liquids, Gases, and Steam.

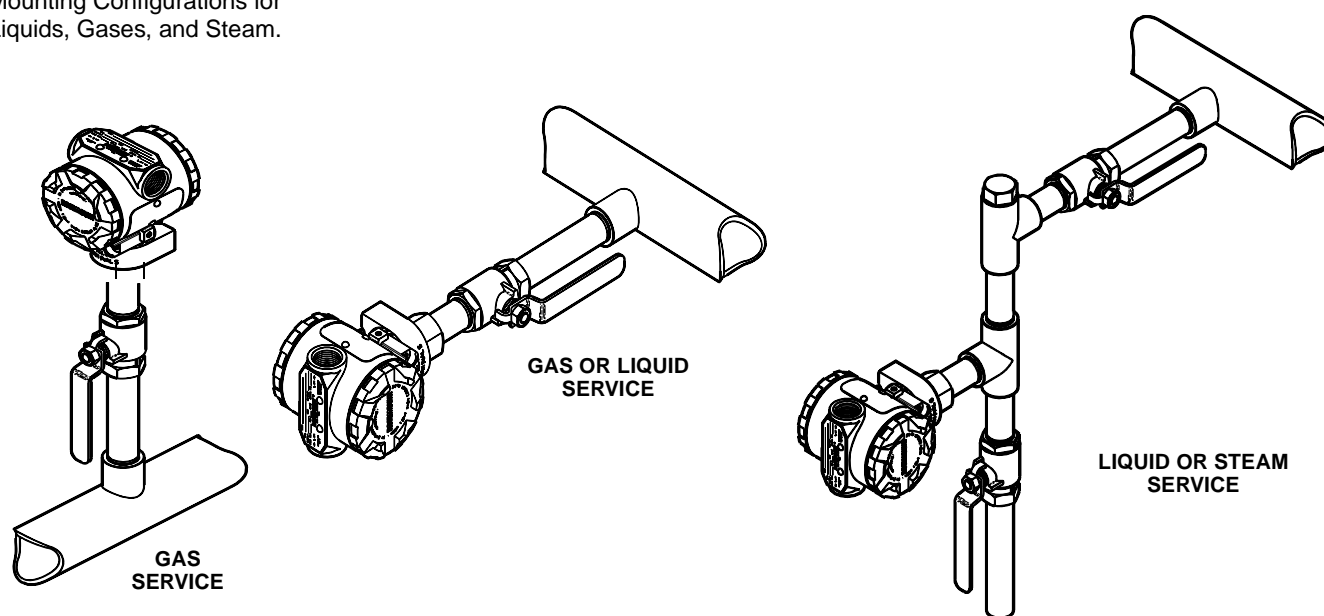

2088-2088A01A, C, B

### NOTE

In steam or other high-temperature services, the temperature at the process connection must not exceed the process temperature limit of the transmitter, which is 250 °F (121 °C).

In steam service above 250 °F (121 °C), fill impulse lines with water to prevent steam from contacting the transmitter. Condensate chambers are not necessary since the volumetric displacement of the Model 2088 is negligible.

**Access Requirements**

When choosing a mounting location and position, take into account the need for access to the transmitter.

Make wiring terminations through the conduit openings at the top of the electronics housing. The field terminal side of the transmitter is clearly marked on the transmitter neck. Test terminals are incorporated on the terminal block; you do not need access to the electronics compartment to perform calibration procedures.

The transmitter electronics compartment contains the electronics module with failure mode and security jumpers, and the optional LCD meter. Consider the need for access to both compartments when installing the transmitter. Refer to Figure 3-4 for transmitter dimensional drawings.

FIGURE 3-4. Smart Transmitter Dimensional Drawings.

**Model 2088**

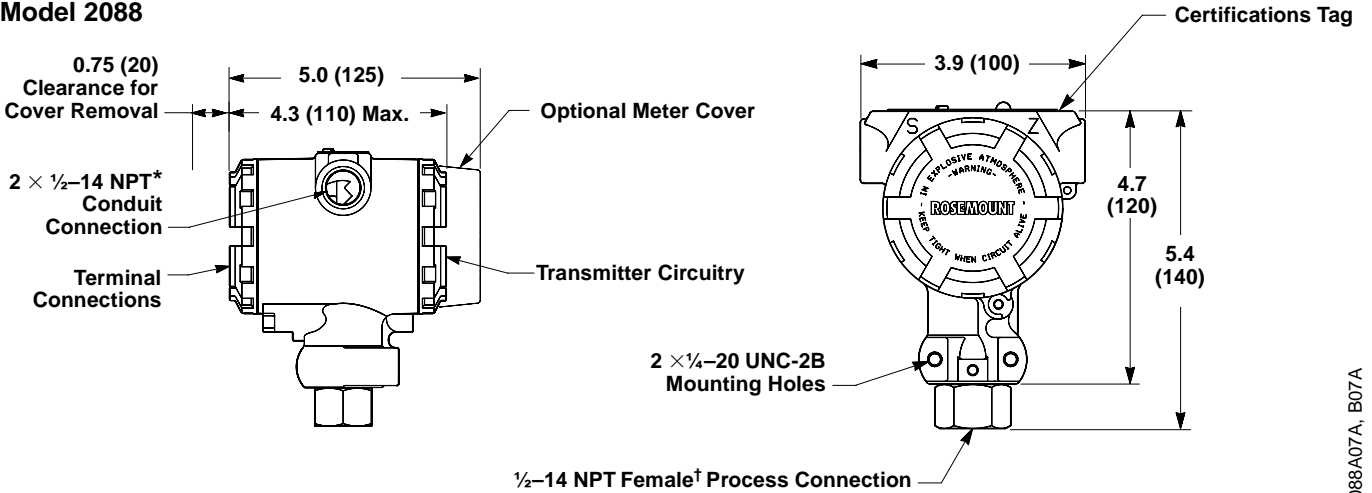

\* M20 × 1.5 Female (CM20), PG 13.5, and G 1/2 Female (PF 1/2) also available as options.  
 † DIN 16288 G 1/2 Male, RC 1/2 Female (PT 1/2), and M20 × 1.5 Male (CM20) also available.

2088S-2088A07A, B07A

**Model 2090P (1.5-in.)**

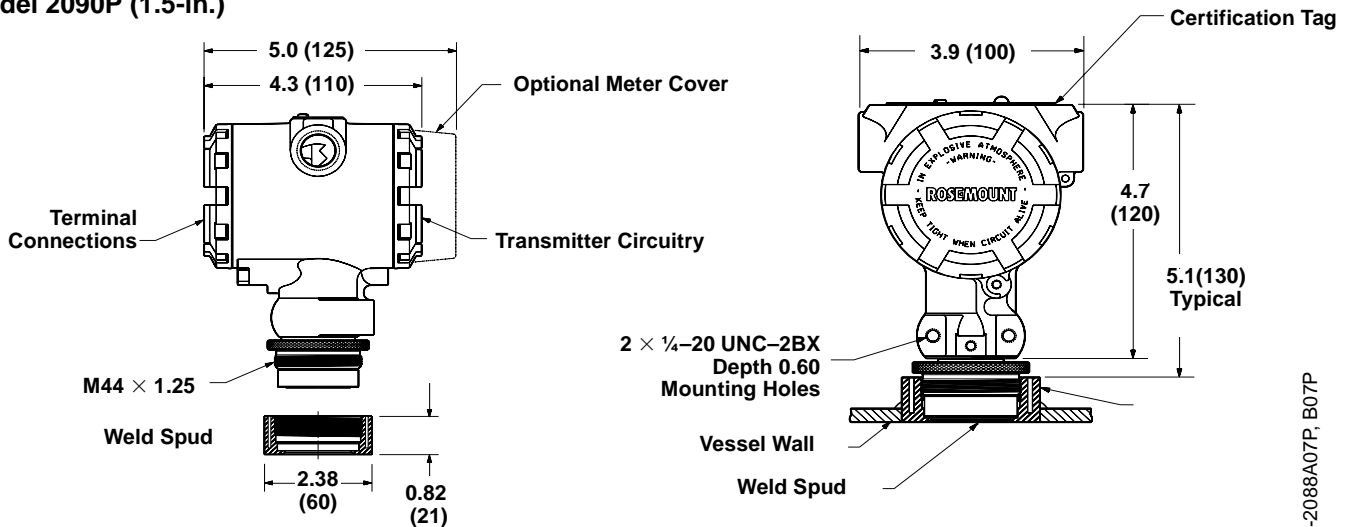

NOTE: Dimensions are in in. (mm).

2090-2088A07P, B07P

**Model 2090P Compatible with 1-in. PMC® Process Connection**

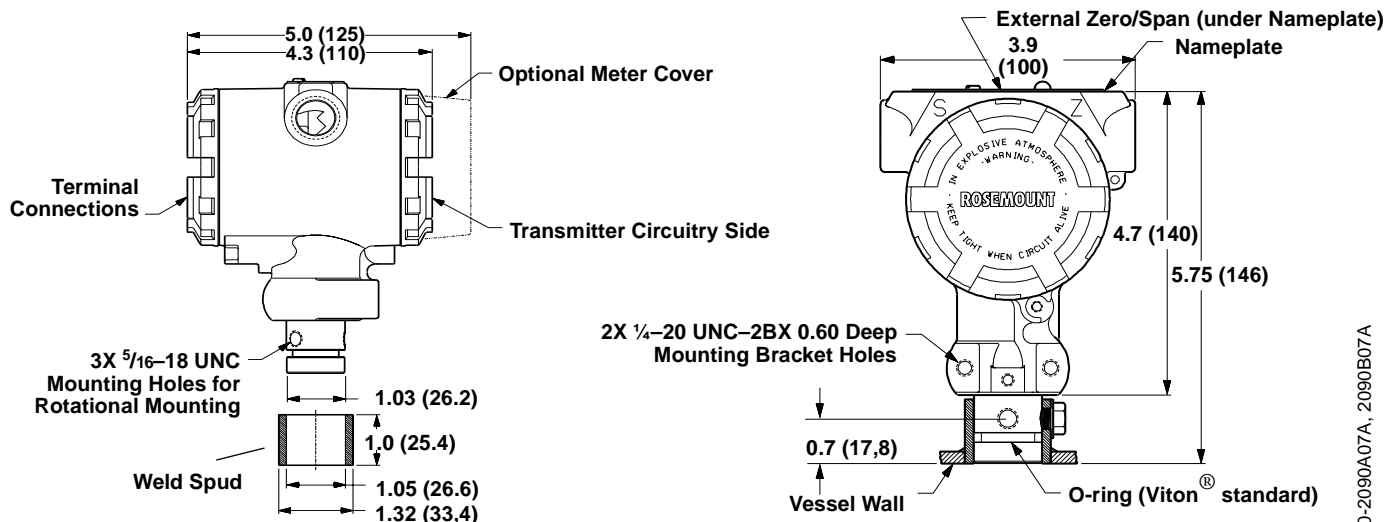

**Model 2090F**

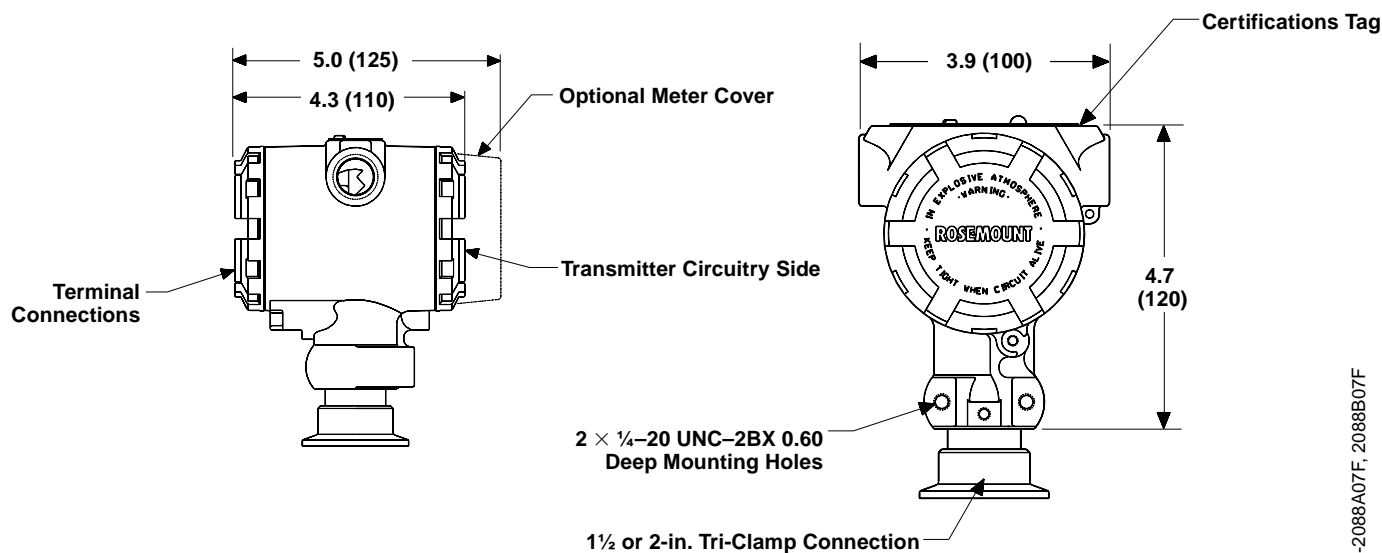

\* M20 x 1.5 Female (M20) and PG 13.5 also available.  
 NOTE: Dimensions are in inches (millimeters).

**Model 2090P**

Installing the Model 2090P transmitter involves attaching a weld spud to the tapped process vessel, attaching the transmitter to the weld spud, and making electrical connections. If you intend to use an existing weld spud, proceed to the transmitter section of this installation procedure.

**NOTE**

The Model 2090P Isolating Diaphragm can be mounted flush with the inside diameter of any vessel larger than three inches in diameter.

**CAUTION**

Installation of the weld spud should be performed by a skilled welder using a TIG welder. Improper installation may result in weld spud distortion.

**Weld Spud**

1. Using the appropriate size hole saw, cut a hole in the process vessel to accept the weld spud. The diameter for a weld spud with heat isolator groove is 2.37 inch (60 mm); when compatible with 1-in. PMC<sup>®</sup> process connection style spud, diameter is 1.32 in. (33,4 mm). The hole should produce a tight, uniform fit when coupled with the weld spud.
2. Bevel the edge of the vessel hole to accept filler material (see Figure 3-5).
3. Remove the weld spud from the transmitter and remove the Teflon<sup>®</sup> gasket from the weld spud.

**⚠ CAUTION**

Excessive heat will distort the weld spud. Weld in sections, as shown in Figure 3-5, cooling each section with a wet cloth. Allow adequate cooling between passes.

To reduce the chances of distorting the weld spud (for 1.5-in. connection), use a heat sink—Rosemount Part Number 02088-0196-0001.

4. Position the weld spud in the vessel hole, place heat sink and tack spud in place using the welding sequence shown in Figure 3-5. Cool each section with a wet cloth before proceeding to the next section.
5. Weld the spud in place using 0.030 to 0.045 in. (0,762 to 1,143 mm) stainless steel rod as filler in the bevelled area. Using between 100 and 125 amps., adjust the amperage for 0.080 in. (2,032 mm) penetration.

**Transmitter**

1. After the weld spud has cooled, remove the heat sink and install the Teflon gasket into the weld spud. Ensure that the gasket is properly positioned within the weld spud; improper placement could cause a process leak (see Figure 3-6).
2. Position the transmitter into the spud and begin to engage the threads. Rotate the transmitter prior to seating the threads completely to enable access to the housing compartments, the conduit entry, and the local indicator.
3. Hand tighten the transmitter using the knurled retaining ring, then snug an additional 1/8 turn with adjustable pliers.

**IMPORTANT**

Do not over-tighten the retaining ring. A spanner wrench (P/N 02088-0193-0001) hole is located on the knurled portion of the retaining ring to assist in transmitter removal if it is over-tightened.

---

FIGURE 3-5. Installing the Weld Spud.

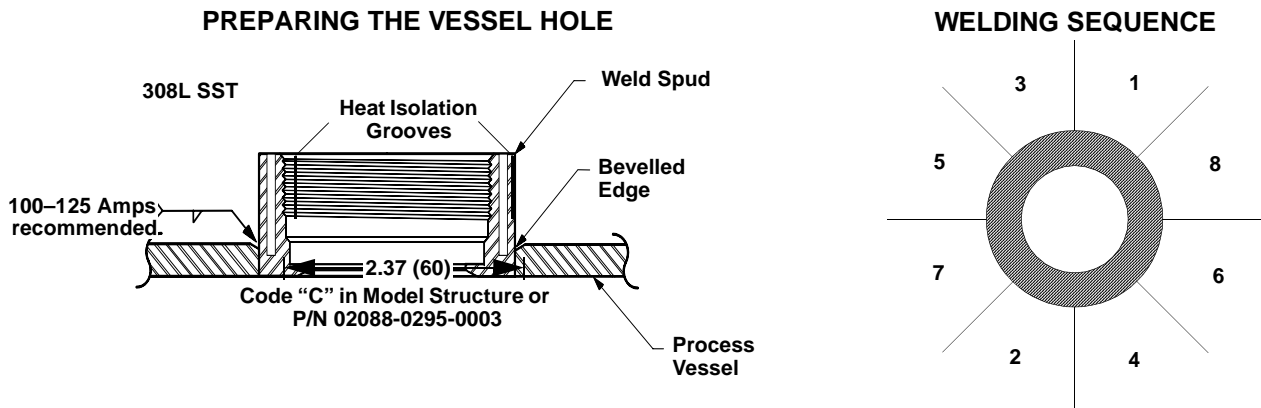

2090-0208E07B

FIGURE 3-6. Teflon Gasket Placement.

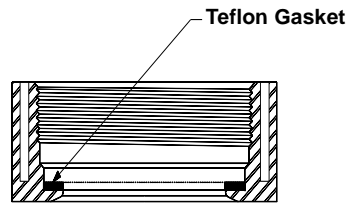

2090-2088E07A

FIGURE 3-7. Model 2090P Mounting Configuration Using a Weld Spud.

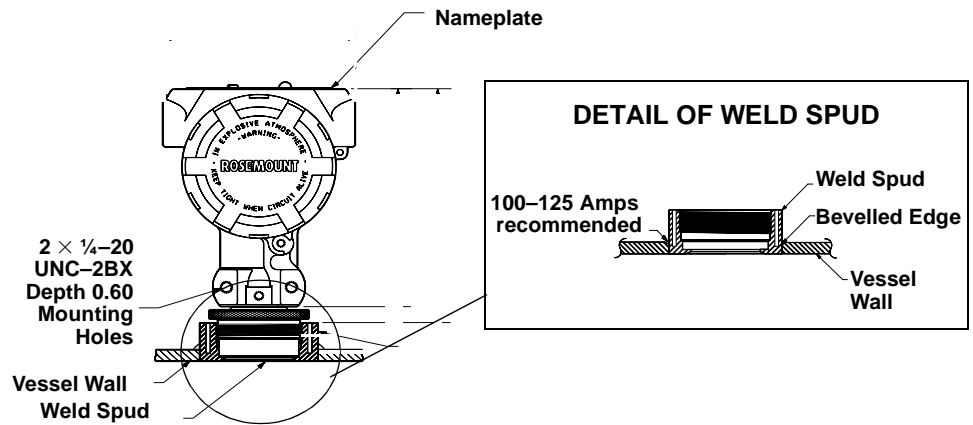

2090-2088E07P, 2088E07B

**Model 2090F**

 The Model 2090F sanitary pressure transmitter is designed to be installed directly to a sanitary fitting. The transmitter is available with either a 1.5- or 2-inch clamp connection.

When installing the transmitter to the sanitary fitting it is important to use the proper sanitary clamp and gasket (user-supplied). Check the clamp and gasket specifications before installing. Refer to *Standard Sanitary Clamp Models* in Figure 3-8 for a list of standard sanitary clamps, their respective maximum pressure ranges, and the recommended torque to be applied when mounting.

FIGURE 3-8. Model 2090F Mounting Configuration Using a Sanitary Fitting.

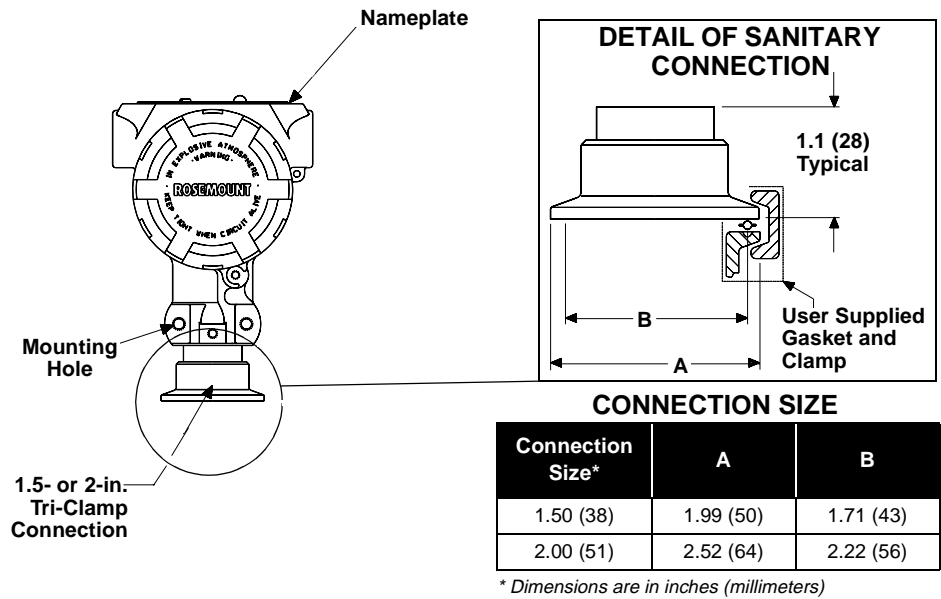

2088-2088B07D, 2090-2088D07A

**STANDARD SANITARY CLAMP MODELS**

Clamp Model	psi @ 70 °F (kPa @ 21 °C)	psi @ 250 °F (kPa @ 121 °C)	Recommended Torque
13 MHHM 1.5-inch	450 (3 103)	250 (1 724)	25 in-lb (2.8 N•m)
13 MHHM 2-inch	500 (3 448)	250 (1 724)	
13 MHHS 1.5-inch	600 (4 138)	300 (2 069)	25 in-lb (2.8 N•m)
13 MHHS 2-inch	550 (3 793)	275 (1 896)	
13 MHP 1.5-inch	1500 (10 345)	1200 (8 276)	20 ft-lb (27 N•m)
13 MHP 2-inch	1000 (6 896)	800 (5 517)	



## ELECTRICAL CONSIDERATIONS

The wiring terminations on the Models 2088, 2090P, and 2090F are located in the side of the transmitter housing marked “FIELD TERMINALS.” Access to these terminations is required during installation and may be necessary during periodic calibration of the transmitter.

### Power Supply

The dc power supply should provide power to the transmitter with less than one percent ripple. The total loop resistance load is the sum of the resistance of the signal wires and the resistance load of the controller, indicator, and other pieces of equipment in the loop. Note that the resistance of intrinsic safety barriers, if used, must be included. Figure 3-9 shows the transmitter power supply load limitations.

FIGURE 3-9. Transmitter Load Limitations.

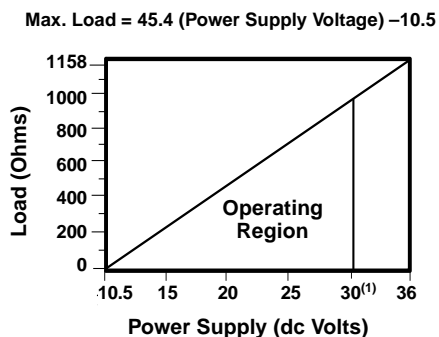

(1) For CENLEC EX ia Approval, power supply must not exceed 30 volts.

**NOTE**

Minimum load impedance for Output Code N is 100 kilohms.

2088-0098A

### Field Wiring

**⚠** All power to the transmitter is supplied over the signal wiring. Signal wiring need not be shielded, but use twisted pairs for best results. Do not run unshielded signal wiring in conduit or open trays with power wiring, or near heavy electrical equipment. To power the transmitter, connect the positive power lead to the terminal marked “PWR/COMM+” and the negative power lead to the terminal marked “-” (see Figure 3-10). Tighten the terminal screws to ensure that proper contact is made. Avoid contact with the leads and the terminals. No additional power wiring is required.

**⚠** To connect test equipment for monitoring the output of the Model 2088 Smart during maintenance procedures, connect one lead to the terminal labeled “TEST+” and the other lead to the terminal labeled “-” (see Figure 3-10). Avoid contact with the leads and the terminals.

Signal wiring may be grounded at any one point on the measurement loop, or it may be left ungrounded. The negative side of the power supply is a recommended grounding point. The transmitter case may be grounded or left ungrounded.

Conduit connections at the transmitter should be sealed to prevent moisture accumulating in the field terminal side of the transmitter housing. Also, install wiring with a drip loop with the bottom of the drip loop lower than the conduit connection of the transmitter housing.

FIGURE 3-10. Model 2088 Smart Signal Wiring Terminals.

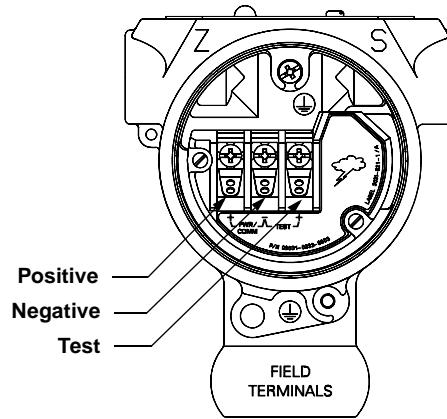

2088S-2088C02D

## FAILURE MODE AND SECURITY JUMPERS

### Failure Mode

As part of normal operation, the Model 2088/2090 Smart Pressure Transmitter continuously monitors its own operation. This automatic diagnostic routine is a timed series of checks repeated continuously. If the diagnostic routine detects a failure in the transmitter, the transmitter drives its output either below or above specific values depending on the position of the failure mode jumper or switch.

The values to which 4–20 mA transmitters drive their output in failure mode depend on whether they are factory-configured to *standard* or *NAMUR-compliant* operation. The values for each are as follows:

#### Standard Operation

Linear output:  $3.9 \leq I \leq 20.8$  mA

Fail low:  $I \leq 3.75$  mA

Fail high:  $I \geq 21.75$  mA

#### NAMUR-Compliant Operation (Option Code C4)

Linear output:  $3.8 \leq I \leq 20.8$  mA

Fail low:  $I \leq 3.6$  mA

Fail high:  $21.0 \leq I \leq 23.0$  mA

To determine the failure mode configuration of your transmitter, review the failure mode options using a Model 275 HART Communicator.

---

#### NOTE

The failure mode configuration, whether standard or NAMUR-compliant, is configured at the factory and can not be changed in the field.

---

## Jumper Locations

**Without a meter installed**

 The failure mode alarm jumper is located on the front side of the electronics module just inside the electronics housing cover and is labeled ALARM (See Figure 3-11). Do not remove the transmitter cover in explosive atmospheres when the circuit is alive. Both covers must be fully engaged to meet explosion-proof requirements.

**With a meter installed**

 The failure mode alarm jumper is located on the LCD faceplate in the electronics module side of the transmitter housing and is labeled ALARM (See Figure 3-11). Do not remove the transmitter cover in explosive atmospheres when the circuit is alive. Both covers must be fully engaged to meet explosion proof requirements.

## Transmitter Security

After commissioning the transmitter, you may wish to protect the configuration data from unwarranted changes. The transmitter is equipped with a security jumper that can be positioned to prevent changes to the configuration data (see Figure 3-11). The circuit board is electrostatically sensitive. Observe handling precautions for static-sensitive components to avoid circuit board damage.

When the transmitter security jumper is in the “ON” position, the transmitter will not accept any “writes” to its memory. This means that configuration changes (such as digital trim and reranging) cannot take place when the transmitter security is on. To reposition the jumper, use the following procedure.

1. If the transmitter is installed, secure the loop, and remove power.
2. Remove the housing cover opposite the field terminal side. Do not remove the instrument cover in explosive atmospheres when the circuit is alive.
3. Reposition the jumper. Avoid contact with the leads and the terminals. Refer to Figure 3-11 for the location of the jumper and the ON and OFF positions.
4. Reattach the transmitter cover. The cover must be fully engaged to comply with explosion-proof requirements.

FIGURE 3-11. Transmitter Alarm and Security Jumper Locations.

Alarm and Security Jumpers Without Meter

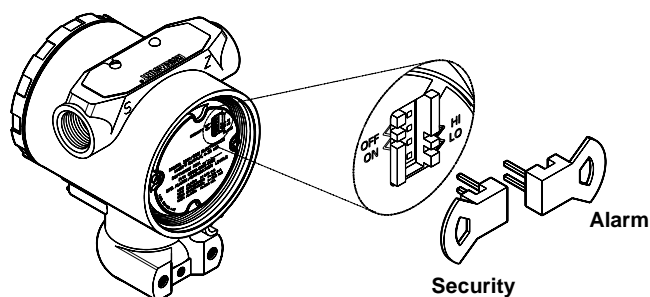

Alarm and Security Jumpers With Meter

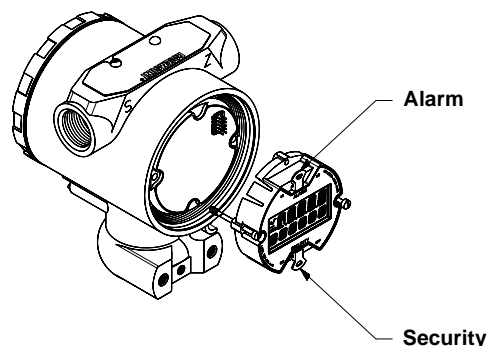

2088S-2088A05A, 2088A05C

### NOTE

If either the alarm or security jumper is dislodged or removed from its position the transmitter reverts to default alarm or security settings of: Alarm: Output high; Security: Off

## ZERO AND SPAN ADJUSTMENTS

The smart Model 2088 is equipped with local zero and span adjustment buttons. The buttons are located on the top of the transmitter beneath the certifications label. Use the zero and span adjustments to set the 4 and 20 mA output points.

### Rerange Procedure

To rerange the transmitter using the span and zero buttons, perform the following procedure.

1. Loosen the screw holding the nameplate on top of the transmitter housing and rotate the nameplate to expose the zero and span buttons (see Figure 3-12).
2. Using a pressure source with an accuracy three to ten times the desired calibrated accuracy, apply a pressure equivalent to the lower range value.
3. To set the 4 mA point, press and hold the zero button for at least two seconds, then verify that the output is 4 mA. If a meter is installed, it will display ZERO PASS.
4. Apply a pressure equivalent to the upper range value.
5. To set the 20 mA point, press and hold the span button for at least two seconds, then verify that the output is 20 mA. If a meter is installed, it will display SPAN PASS.

#### NOTE

If the transmitter security jumper is in the “ON” position, or if the local zero and span adjustments are disabled through the software, you will not be able to make adjustments to the zero and span using the local buttons. Refer to Figure 3-11 on page 3-13 for the proper placement of the transmitter security jumper.

FIGURE 3-12. Local Zero and Span Adjustments.

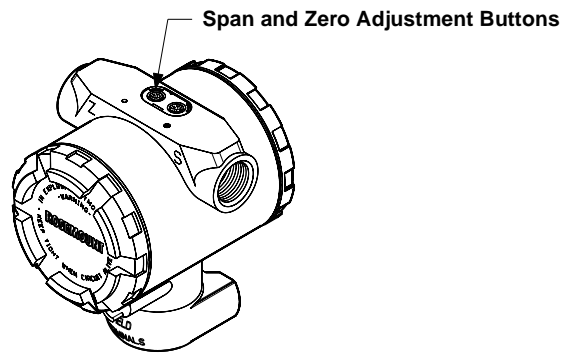

2088S-2088A02A

### Disabling the Zero and Span Adjustments

After you rerange the transmitter using the span and zero adjustments, you may wish to disable the adjustments to prevent further reranging. To disable the span and zero adjustments, activate the transmitter security jumper (see Transmitter Security on Page 3-13).

#### NOTE

The transmitter security jumper prevents any changes to the transmitter configuration data. The software lockout sequence only disables the local span and zero adjustment buttons.





# Maintenance and Troubleshooting

This section contains the following transmitter maintenance and troubleshooting information:

- Troubleshooting
- Disassembly Procedure
- Reassembly Procedure
- Return of Materials
- Replacement Parts

## SAFETY MESSAGES

This section contains procedures that require connecting a communicator to the transmitter, or making connections in an explosive atmosphere. The following safety messages apply to all procedures throughout this section requiring cover removal and communicator or ammeter connection to the transmitter terminal block. Keep the following safety messages in mind whenever you perform an operation requiring cover removal or the connection of a communicator or other device to a measurement loop.

### WARNING

The following performance limitations may inhibit efficient or safe operation. Critical applications should have appropriate diagnostic and backup systems in place.

Pressure transmitters contain an internal fill fluid. It is used to transmit the process pressure through the isolating diaphragms to the pressure sensing element. In rare cases, oil leak paths in oil-filled pressure transmitters can be created. Possible causes include: physical damage to the isolator diaphragms, process fluid freezing, isolator corrosion due to an incompatible process fluid, etc.

A transmitter with an oil fill fluid leak can continue to perform normally for a period of time. Sustained oil loss will eventually cause one or more of the operating parameters to exceed published specifications while a small drift in operating point output continues. Symptoms of advanced oil loss and other unrelated problems include:

- Sustained drift rate in true zero and span or operating point output or both.
- Sluggish response to increasing or decreasing pressure or both.
- Limited output rate or very nonlinear output or both.
- Change in output process noise.
- Noticeable drift in operating point output.
- Abrupt increase in drift rate of true zero or span or both.
- Unstable output.
- Output saturated high or low.

**⚠ WARNING**

Unauthorized procedures or parts can affect product performance and the output signal used to control a process, and can cause death or serious injury. Use only the procedures and new parts specifically referenced in this manual. Direct any questions concerning these procedures or parts to Rosemount Inc.

**⚠ WARNING**

Explosions can result in death or serious injury. Do not remove the instrument cover in explosive environments while power is supplied to transmitter.

**⚠ WARNING**

Mishandling products exposed to a hazardous substance can cause death or serious injury. If the product being returned was exposed to a hazardous substance as defined by OSHA, a copy of the required Material Safety Data Sheet (MSDS) for each hazardous substance identified must be included with the returned goods.

FIGURE 4-1. Range of Output.

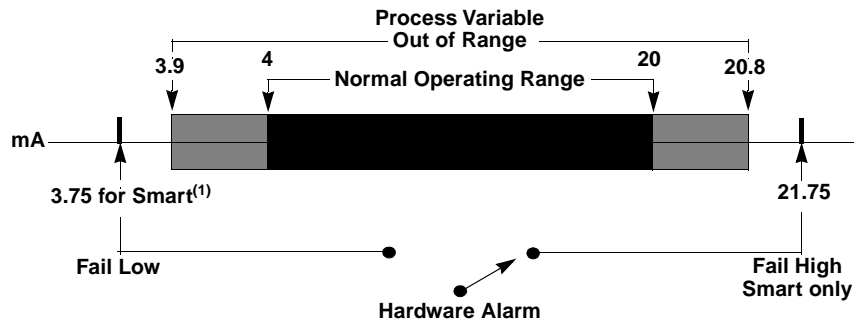

(1) Failure mode for output code M is  $\leq 1V$ .  
 (2) Above Values are for Standard Failure Mode. NAMUR compliant values are different than above.



## TROUBLESHOOTING

TABLE 4-1. Smart Transmitter Troubleshooting and Corrective Actions.

Symptom	Potential Source	Corrective Action
High Output	Impulse Piping,	<ul style="list-style-type: none"> <li>• Check for blockage in the impulse line.</li> <li>• Check to ensure that the blocking valve is fully open.</li> <li>• Check for trapped gas in a liquid line, or trapped liquid in a gas line.</li> <li>• Check to ensure that the density of the fluid in the impulse line is unchanged.</li> <li>• Check for sediment in the transmitter process connection. If you find sediment, flush the process connection clean with water or an appropriate solvent. <b>Do not attempt to scrape sediment free;</b> doing so could puncture the thin isolating diaphragm and destroy the transmitter.</li> <li>• Check for frozen process fluid in the process connector.</li> </ul>
	Electronics	<ul style="list-style-type: none"> <li>• Check test equipment.</li> <li>• Perform full sensor trim.</li> </ul>
	Power Supply	<ul style="list-style-type: none"> <li>• Check the output voltage of the power supply at the transmitter.<sup>(1)</sup></li> </ul>
	Other Components	<ul style="list-style-type: none"> <li>• Replace the transmitter.</li> </ul>
Erratic Output	Impulse Piping	<ul style="list-style-type: none"> <li>• Check for leaks or blockage in the impulse line.</li> <li>• Check to ensure that the blocking valve is fully open.</li> <li>• Check for trapped gas in a liquid line, or trapped liquid in a gas line.</li> <li>• Check to ensure that the density of the fluid in the impulse line is unchanged.</li> <li>• Check for sediment in the transmitter process connection. If you find sediment, flush the process connection clean with water or an appropriate solvent.</li> <li>• Check for frozen process fluid in the process connector.</li> <li>• Check for trapped gas in a liquid line, or trapped liquid in a gas line.</li> </ul>
	Loop Wiring	<ul style="list-style-type: none"> <li>• Check for adequate voltage to the transmitter.<sup>(1)</sup></li> <li>• Check for intermittent shorts, open circuits, and multiple grounds.</li> </ul>
	Electronics	<ul style="list-style-type: none"> <li>• Check for EMF interference.</li> <li>• Check damping.</li> <li>• Replace the output board and recalibrate the transmitter.</li> </ul>
	Other Components	<ul style="list-style-type: none"> <li>• Replace the transmitter.</li> </ul>
Low Output or No Output	Impulse Piping	<ul style="list-style-type: none"> <li>• Check for leaks or blockage in the impulse line.</li> <li>• Check to ensure that the blocking valve is fully open.</li> <li>• Check for trapped gas in a liquid line, or trapped liquid in a gas line.</li> <li>• Check to ensure that the density of the fluid in the impulse line is unchanged.</li> <li>• Check for sediment in the transmitter process connection. If you find sediment, flush the process connection clean with water or an appropriate solvent. <b>Do not attempt to scrape sediment free;</b> doing so could puncture the thin isolating diaphragm and destroy the transmitter.</li> <li>• Check for frozen process fluid in the process connector.</li> </ul>
Low Output or No Output	Loop Wiring	<ul style="list-style-type: none"> <li>• Check test equipment.</li> <li>• Check for adequate voltage to the transmitter.<sup>(1)</sup></li> <li>• Check the current rating of the power supply against the total current being drawn by all transmitters being powered.</li> <li>• Check for intermittent shorts, open circuits, and multiple grounds.</li> <li>• Check for proper polarity at the signal terminals.</li> <li>• Check the loop impedance.</li> </ul>
	Electronics	<ul style="list-style-type: none"> <li>• Replace the electronics board and recalibrate the transmitter.</li> </ul>
	Other Components	<ul style="list-style-type: none"> <li>• Replace the transmitter.</li> </ul>

(1) A transmitter with Output Code S should have 10.5–36.0 V dc with no load at the terminals; A transmitter with Output Code M should have 6.0–14.0 V dc.

TABLE 4-2. Analog Transmitter Troubleshooting Symptoms and Corrective Actions.

Symptom	Potential Source	Corrective Action
High Output	Impulse Piping	<ul style="list-style-type: none"> <li>• Check for blockage in the impulse line.</li> <li>• Check to ensure that the blocking valve is fully open.</li> <li>• Check for trapped gas in a liquid line, or trapped liquid in a gas line.</li> <li>• Check to ensure that the density of the fluid in the impulse line is unchanged.</li> <li>• Check for sediment in the transmitter process connection. If you find sediment, flush the process connection clean with water or an appropriate solvent. <b>Do not attempt to scrape sediment free;</b> doing so could puncture the thin isolating diaphragm and destroy the transmitter.</li> <li>• Check for frozen process fluid in the process connector.</li> </ul>
	Power Supply	<ul style="list-style-type: none"> <li>• Check the output voltage of the power supply at the transmitter.<sup>(1)</sup></li> </ul>
	Output Electronics	<ul style="list-style-type: none"> <li>• Replace the output board and recalibrate the transmitter.</li> </ul>
	Other Components	<ul style="list-style-type: none"> <li>• Replace the transmitter.</li> </ul>
Symptom	Potential Source	Corrective Action
Erratic Output	Impulse Piping	<ul style="list-style-type: none"> <li>• Check for leaks or blockage in the impulse line.</li> <li>• Check to ensure that the blocking valve is fully open.</li> <li>• Check for trapped gas in a liquid line, or trapped liquid in a gas line.</li> <li>• Check to ensure that the density of the fluid in the impulse line is unchanged.</li> <li>• Check for sediment in the transmitter process connection. If you find sediment, flush the process connection clean with water or an appropriate solvent.</li> <li>• Check for frozen process fluid in the process connector.</li> <li>• Check for trapped gas in a liquid line, or trapped liquid in a gas line.</li> </ul>
	Loop Wiring	<ul style="list-style-type: none"> <li>• Check for adequate voltage to the transmitter.<sup>(1)</sup></li> <li>• Check for intermittent shorts, open circuits, and multiple grounds.</li> </ul>
	Output Electronics	<ul style="list-style-type: none"> <li>• Replace the output board and recalibrate the transmitter.</li> </ul>
	Other Components	<ul style="list-style-type: none"> <li>• Replace the transmitter.</li> </ul>
Low Output or No Output	Impulse Piping	<ul style="list-style-type: none"> <li>• Check for leaks or blockage in the impulse line.</li> <li>• Check to ensure that the blocking valve is fully open.</li> <li>• Check for trapped gas in a liquid line, or trapped liquid in a gas line.</li> <li>• Check to ensure that the density of the fluid in the impulse line is unchanged.</li> <li>• Check for sediment in the transmitter process connection. If you find sediment, flush the process connection clean with water or an appropriate solvent. <b>Do not attempt to scrape sediment free;</b> doing so could puncture the thin isolating diaphragm and destroy the transmitter.</li> <li>• Check for frozen process fluid in the process connector.</li> </ul>
	Loop Wiring	<ul style="list-style-type: none"> <li>• Check for adequate voltage to the transmitter.<sup>(1)</sup></li> <li>• Check the current rating of the power supply against the total current being drawn by all transmitters being powered.</li> <li>• Check for intermittent shorts, open circuits, and multiple grounds.</li> <li>• Check for proper polarity at the signal terminals.</li> <li>• Check the loop impedance.</li> </ul>
	Output Electronics	<ul style="list-style-type: none"> <li>• Replace the output board and recalibrate the transmitter.</li> </ul>
	Other Components	<ul style="list-style-type: none"> <li>• Replace the transmitter.</li> </ul>

(1) A transmitter with Output Code A should have 10.5–36.0 V dc with no load at the terminals; A transmitter with Output Code M should have 6.0–14.0 V dc.

## DOWNSCALE ALARM

Models 2088, 2090P, and 2090F transmitters can identify certain types of failure conditions. These failures may arise from four possible sources:

1. No updated information is being received by the microprocessor from the sensor.
2. The sensor is damaged.
3. Calibration information for zero and span is not being stored correctly within the memory of the microprocessor.
4. Microprocessor malfunction.

If the transmitter experiences failure conditions, it drives the output below the lower output limit (less than 3.75 mA for Output Code S; less than 1 V for Output code M), and if a local indicator is installed, it displays “FAIL.” If the transmitter encounters the first or second condition it locks the output at the lower limit. If the transmitter encounters the third condition it locks the output at the lower limit after the switch is turned to the “RUN” position.

If you experience downscale alarm, momentarily interrupt power to the transmitter. After re-applying power, attempt to reset the calibration point that caused the failure. If the transmitter does not accept the set value after repeated attempts, the microprocessor board is probably inoperable. Check the operation of the microprocessor board by eliminating other sources of low output (i.e. blocked impulse piping). Remove the output board for spare parts and replace the transmitter.

## DISASSEMBLY PROCEDURE



You can easily repair the Models 2088, 2090P, and 2090F Pressure Transmitters in the event of a malfunction in the output stage of the transmitter electronics.

To remove the output circuit board use the following procedure:

### CAUTION

Disconnect power to the transmitter before removing the output board. Failure to follow this procedure could result in permanent damage to the transmitter electronics.

1. Remove the cover from the electronics side of the transmitter housing.
2. Loosen the two captive screws that hold the output board in place.
3. Carefully remove the output board from the multi-pin connector and the power leads.

## REASSEMBLY PROCEDURE

To replace the output circuit board use the following procedure:

### CAUTION

The circuit board is electrostatically sensitive. To prevent damage to the circuit board, observe handling precautions for static-sensitive components.

1. Align the two long power leads on the transmitter electronics board with the power receptacles on the output board. Gently insert the power leads into the receptacles.
2. Align the multi-pin connector on the output board with the receptacles on the transmitter electronics board. Gently insert the multi-pin connector into the receptacles.
3. Push the board firmly into position and tighten the screws.

To view an exploded view, see Figure 5-1 on page 5-7.



**RETURNING ROSEMOUNT  
PRODUCTS AND/OR  
MATERIALS**



To expedite the return process outside the United States, contact the nearest Rosemount representative.

Within the United States, call the Rosemount National Response Center using the 1-800-654-RSMT (7768) toll-free number. This center, available 24 hours a day, will assist you with any needed information or materials.

The center will ask for product model and serial numbers, and will provide a Return Material Authorization (RMA) number. The center will also ask for a description of the process material to which the product was last exposed.

The Rosemount National Response Center will detail the additional information and procedures necessary to return goods exposed to hazardous substances.



# Specifications and Reference Data

## OVERVIEW

This section contains the following transmitter specifications and reference data:

- Model 2088, Model 2090P, and Model 2090F
  - Functional Specifications
  - Performance Specifications
  - Physical Specifications
- Spare Parts
- Ordering Information

## FUNCTIONAL SPECIFICATIONS

### Service

#### Model 2088

Liquid, gas, and vapor applications.

#### Model 2090P

Liquid, gas, vapor, and high-viscosity applications.

#### Model 2090F

Liquid, gas, vapor, and sanitary applications.

### Ranges for Model 2088

Range	Minimum Span (Smart)	URL/Max.span/Sensor Limit
1	1.5 psi (103 mbar)	30 psi (2,06 bar)
2	7.5 psi (517 mbar)	150 psi (10,34 bar)
3	40 psi (2,76 bar)	800 psi (55,15 bar)
4	200 psi (13,8 bar)	4000 psi (275,79 bar)

### Ranges for Model 2090F

Range	Minimum Span (Smart)	URL/Max.span/Sensor Limit
1	1.5 psi (103 mbar)	30 psi (2,06 bar)
2	7.5 psi (517 mbar)	150 psi (10,34 bar)
3	40 psi (2,76 bar)	300 psi (20,68 bar)

### Ranges for Model 2090P

Range	Minimum Span (Smart)	URL/Max.span/Sensor Limit
1	1.5 psi (103 mbar)	30 psi (2,06 bar)
2	7.5 psi (517 mbar)	150 psi (10,34 bar)
3	40 psi (2,76 bar)	300 psi (20,68 bar)

**Output**

Code S: 4–20 mA dc.

**Load Limitations<sup>(1)</sup>**

Maximum loop resistance is determined by the power supply voltage, as described by:

$$\text{Max. Loop Resistance} = 45.4 \times (\text{Power Supply Voltage} - 10.5)$$

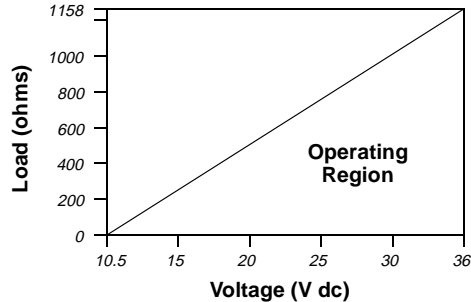

**Note:** Communication requires minimum loop resistance: 250 ohm:

**Power Supply**

External power supply<sup>(2)</sup> required. Transmitter operates on 10.5–36 V dc with no load. Reverse polarity protection is standard.

**Zero Elevation and Suppression**

Zero can be suppressed between atmosphere for gage transmitters, or 0 psia for absolute transmitters, and upper range limit, provided the calibrated span is equal to or greater than the minimum span, and the upper range value does not exceed the upper range limit. Vacuum calibrations are allowed on the Model 2088G transmitter with compound range option (CR).

**Overpressure Limits**

- Ranges 0 and 1: 120 psig max.
- All other ranges: twice the upper range limit.

**Temperature Limits**

**Process**

- Model 2088     Silicone fill sensor: –40 to 250 °F (–40 to 121 °C).  
                         Inert fill sensor: –22 to 250 °F (–30 to 121 °C).
- Model 2090P    –4 to 250 °F (–20 to 121 °C).
- Model 2090F    –4 to 284 °F (–20 to 140 °C).

**Ambient:**

- Model 2088     –40 to 185 °F (–40 to 85 °C).  
                         –4 to 175 °F (–20 to 80 °C) with LCD meter.
- Model 2090P    –4 to 185 °F (–20 to 85 °C).
- Model 2090F    –4 to 185 °F (–20 to 85 °C).

**Storage:**

- Model 2088     –50 to 230 °F (–46 to 110 °C).  
                         –40 to 185 °F (–40 to 85 °C) with LCD meter.
- Model 2090P    –50 to 185 °F (–45 to 85 °C).
- Model 2090F    –22 to 185 °F (–30 to 85 °C).

(1) Minimum load impedance for Output Code M is 100 kilohms.  
 (2) For CENELEC Ex ia approval, the power supply must not exceed 30 volts.

Process temperatures above 185 °F (85 °C) require derating the ambient limits:

$$\text{Maximum Ambient Temperature in } ^\circ\text{F} = 185 - \frac{(\text{Process Temp} - 185)}{1.5}$$

$$\text{Maximum Ambient Temperature in } ^\circ\text{C} = 85 - \frac{(\text{Process Temp} - 85)}{1.5}$$

#### Humidity Limits

0–100% relative humidity.

#### Volumetric Displacement

Less than 0.00042 cm<sup>3</sup>.

#### Turn-on Time

##### Output Code S

2.0 seconds, no warm-up required.

#### Failure Mode

##### Output Code S

If self-diagnostics detect a sensor or microprocessor failure, the analog signal is driven either high or low to alert the user. High or low failure mode is user-selectable with a jumper on the transmitter. The values to which the transmitter drives its output in failure mode depend on whether it is factory-configured to *standard* or *NAMUR-compliant* operation. The values for each are as follows:

##### Standard Operation

Linear Output:  $3.9 \leq I \leq 20.8$

Fail High:  $I \geq 21.75$  mA

Low:  $I \leq 3.75$  mA

##### NAMUR-Compliant Operation (Option Code C4)

Linear Output:  $3.8 \leq I \leq 20.5$

Fail High:  $I \geq 22.5$  mA

Low:  $I \leq 3.6$  mA

## PERFORMANCE SPECIFICATIONS

(Zero-based spans, reference conditions, and 316 SST isolating diaphragm.)

#### Reference Accuracy

##### Output Code S

±0.20% of calibrated span. Includes combined effects of linearity, hysteresis, and repeatability.

#### Ambient Temperature Effect

Expressed as a total effect per 100 °F (56 °C).

##### Output Code S

± (0.3% URL + 0.3% of span) from –40 to 185 °F (–40 to 85 °C).

#### Stability

##### Output Code S

±0.10% of upper range limit for 12 months.

#### Vibration Effect

Less than ±0.1% of upper range limit when subjected to vibration of: peak to peak constant displacement of 4 mm (5–15 Hz) and constant acceleration of 2 g (15–150 Hz) and 1 g (150–2000 Hz).

#### Power Supply Effect

Less than 0.01% of calibrated span per volt.

### Mounting Position Effect

Zero shift of up to 1.2 inH<sub>2</sub>O (3 mbar), which can be calibrated out. No span effect.

### RFI Effect

Less than  $\pm 0.25\%$  of upper range limit from 20–1000 MHz at 30 V/m with leads in conduit. Less than  $\pm 0.25\%$  of upper range limit at 10 V/m with unshielded twisted pair (no conduit).

### Transient Protection Limits

#### IEEE 587 Category B

6 kV Crest ( $1.2 \times 50 \mu\text{s}$ ).

3 kV Crest ( $8 \times 20 \mu\text{s}$ ).

6 kV Crest ( $0.5 \mu\text{s}$  by 100 kHz).

#### IEEE 472

SWC 2.5 kV Crest.

1 MHz waveform.

### General Specifications

Tested to IEC 801-3.

### Ordinary Location Certification

#### Factory Mutual (FM) Approval

As standard, the transmitter has been examined and tested to determine that the design meets basic electrical, mechanical, and fire protection requirements by FM, a nationally recognized testing laboratory (NRTL) as accredited by the Federal Occupational Safety and Health Administration (OSHA).

### Hazardous Locations Certifications

#### Factory Mutual (FM) Approvals

- E5** Explosion Proof for Class I, Division 1, Groups B, C, and D.  
Dust-Ignition Proof for Class II, Division 1, Groups E, F, and G.  
Suitable for Class III, Division 1, indoor and outdoor (NEMA 4X) hazardous locations; factory sealed.
- I5** Intrinsically safe for use in Class I, Division 1, Groups A, B, C, D; Class II, Division 1, Groups E, F, and G; and Class III, Division 1 when connected in accordance with Rosemount drawing 02088-1018. Non-incendive for Class I, Division 2, Groups A, B, C, and D.

#### Canadian Standards Association (CSA) Approvals

- C6** Explosion Proof for Class I, Division 1, Groups B, C, and D.  
Dust-Ignition Proof for Class II, Division 1, Groups E, F, and G.  
Suitable for Class III, indoor and outdoor hazardous locations, CSA enclosure Type 4X; factory sealed. Approved for Class I, Division 2, Groups A, B, C, and D.  
  
Intrinsically Safe for Class I, Division 1, Groups A, B, C, and D.  
Temp. Code T3C. Intrinsically safe when connected with approved barriers in accordance with Rosemount drawing 02088-1024.

#### CENELEC Flameproof Approvals

- E8** Centro Elettrotecnico Sperimentale Italiano (CESI) Flameproof Approval (*Analog only*)  
Certification Number Ex 91C120.  
EEx d IIC T4 ( $T_{\text{amb}} = 80 \text{ }^\circ\text{C}$ )  
EEx d IIC T6 ( $T_{\text{amb}} = 40 \text{ }^\circ\text{C}$ ).
- ED** KEMA/CENELEC 97 ATEX 2378 (*Smart only*)  
EEx d IIC T4 ( $T_{\text{amb}} = 80 \text{ }^\circ\text{C}$ )  
EEx d IIC T6 ( $T_{\text{amb}} = 40 \text{ }^\circ\text{C}$ ).



**British Approvals Service for Electrical Equipment in Flammable Atmospheres (BASEEFA) Approvals****I1** BASEEFA/CENELEC Intrinsic Safety

Ex 90C2158 for analog transmitters

Ex97D2276X for smart transmitters.

EEx ia IIC T5 ( $T_{amb} = 40\text{ }^{\circ}\text{C}$ ).EEx ia IIC T4 ( $T_{amb} = 70\text{ }^{\circ}\text{C}$ ).**N1** BASEEFA Type N Certification

Ex 90Y4159 for analog transmitters

Ex 97Y4277X for smart transmitters.

Ex N IIC T5 ( $T_{amb} = 70\text{ }^{\circ}\text{C}$ ).**Standards Association of Australia (SAA)****Explosion Proof (Flameproof) Certification****E7** Ex d IIC T6 ( $T_{amb} = 40\text{ }^{\circ}\text{C}$ ) (Available with analog output, Code A, only.)**I7** Ex ia IIC T6. (Available with analog output, Code A, only.)Ex ia IIC T4 ( $T_{amb} = 70\text{ }^{\circ}\text{C}$ ).**Combinations of Approvals****K5** Combination of E5 and I5**K6** Analog: Combination of C6, I1, and E8.

SMART: Combination of C6, I1, and ED.

**PHYSICAL  
SPECIFICATIONS****Electrical Connection** $\frac{1}{2}$ –14 NPT, M20  $\times$  1.5 (CM20), PG 13.5, or G  $\frac{1}{2}$  female (PF  $\frac{1}{2}$  female) conduit entry.**Process Connection****Model 2088** $\frac{1}{2}$ –14 NPT female, DIN 16288 G  $\frac{1}{2}$  male, RC  $\frac{1}{2}$  female (PT  $\frac{1}{2}$  female), M20  $\times$  1.5 (CM20) male.**Model 2090P**M44  $\times$  1.25 male, compatible with a 1-in. PMC<sup>®</sup> process connection.**Model 2090F**1 $\frac{1}{2}$ -inch or 2-inch Tri-Clamp Connection**Process Wetted Parts****Isolating Diaphragm****Model 2088** 316L stainless steel or Hastelloy.**Model 2090P** 316L stainless steel.**Model 2090F** 316L stainless steel.**Process Connector****Model 2088** 316L stainless steel or Hastelloy.**Model 2090P** 316L stainless steel.  
TFE process connector gasket.**Model 2090F** 316L stainless steel.**Non-wetted Parts****Electronics Housing**

Low-copper aluminum, NEMA 4X, IP65, IP67, CSA enclosure Type 4X.

**Paint**

Polyurethane.

**Cover O-rings**

Buna-N.

**Fill Fluid**

**Model 2088** Silicone or inert fill.

**Model 2090P** Silicone

**Model 2090F** Neobee

**Weight**

**Model 2088** Approximately 2.44 lb (1,11 kg).

**Model 2090P** Approximately 2.96 lb (1,34 kg).

**Model 2090F** Approximately 2.74 lb (1,24 kg).

**Accessory Block and Bleed Valve (S5 Option)**

For information on Model 306 Integral Manifold (pre-assembled to transmitter and leak checked), refer to Product Data Sheet 00813-0100-4733.

## SPARE PARTS

FIGURE 5-1. Replacement Parts for the Model 2088 Smart Transmitter.

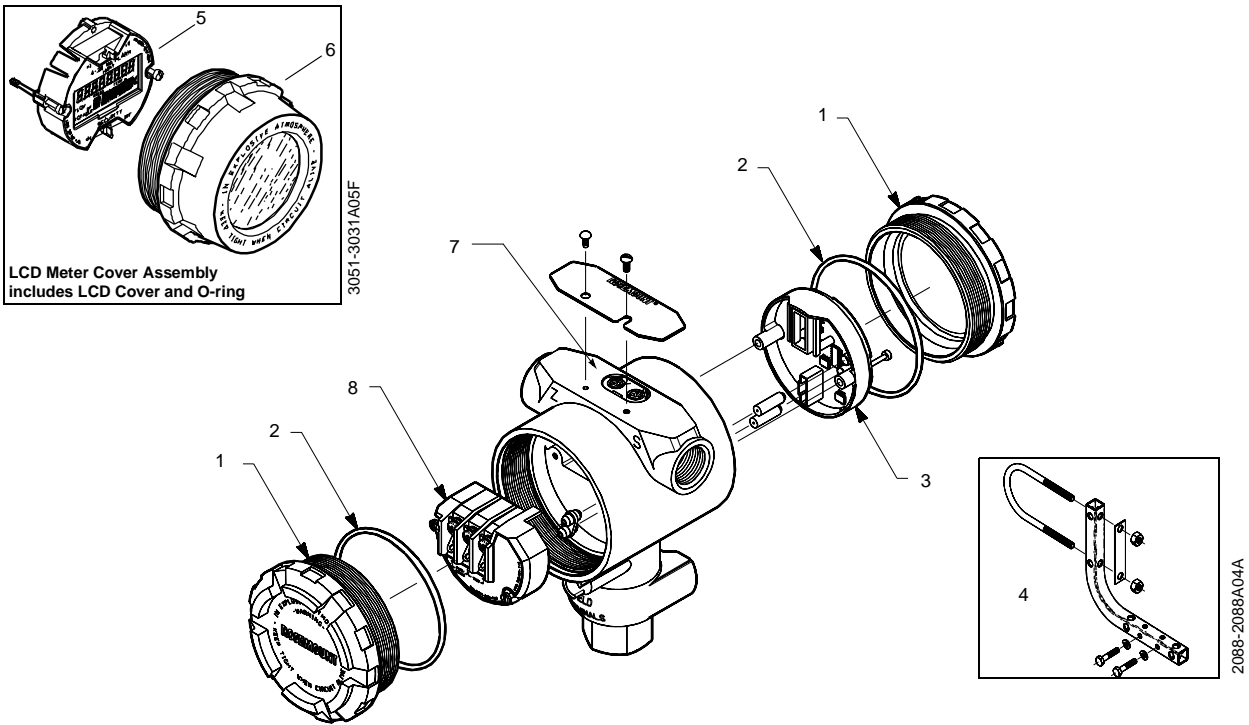

Item No.	Part Description	Part Number	Spares Category <sup>(1)</sup>
1, 2	<b>Smart Transmitters (Output Code S)</b> Electronics Cover (with O-ring)	03031-0292-0001	—
6	LCD Meter Cover Assembly	03031-0193-0002	B
2	Cover O-rings	03031-0232-0001	B
3	Electronics Board Kits S Output (4–20 mA/Digital HART Protocol)	02088-0306-0002	A
3	S Output (NAMUR Compliant Operation)	02088-0306-0003	A
4	Optional Mounting Bracket (with 2-inch U-Bolt for Pipe Mounting)	02088-0071-0001	—
5, 6	LCD Meter Kit with Cover	03031-0193-0101	—
5	LCD Meter Kit without Cover	03031-0193-0103	A
7	Local Zero and Span Kit	3031-0293-0002	A
8	Standard Terminal Block	3031-0332-0003	B
8	Transient Protection Block	3031-0332-0004	B

(1) One spare part is recommended for every 25 transmitters in category A, and one spare part for every 50 transmitters in category B.

# Rosemount Model 2088/2090 Pressure Transmitters

FIGURE 5-2. Replacement Parts for the Model 2090P.

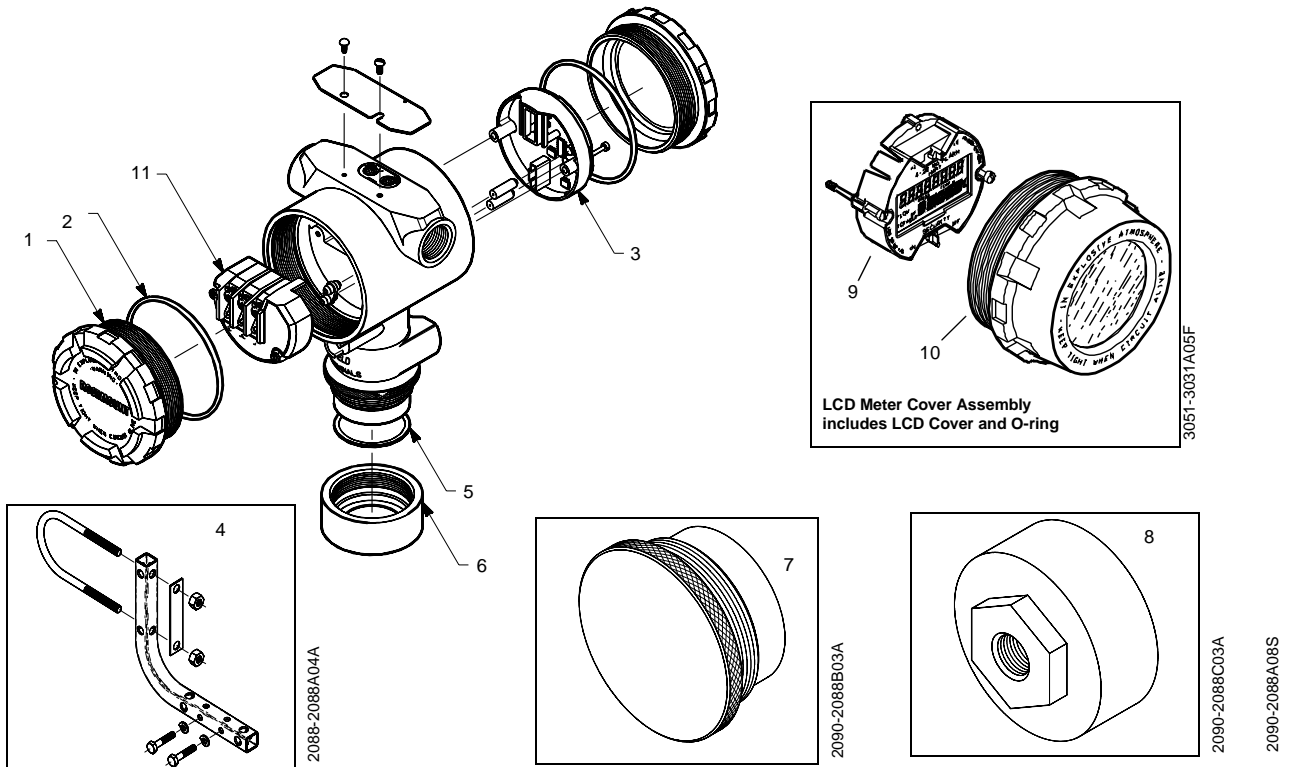

Item No.	Part Description	Part Number	Category <sup>(1)</sup>
1,2	<b>Smart Transmitters (Output Code S)</b> Electronics Cover (with O-ring)	03031-0292-0001	—
10	LCD Meter Cover Assembly	03031-0193-0002	B
2	Cover O-rings	03031-0232-0001	B
3	Electronics Boards S Output (4–20 mA/Digital HART Protocol)	02088-0306-0002	A
3	S Output (NAMUR Compliant Operation)	02088-0306-0003	A
4	Optional Mounting Bracket (with 2-inch U-Bolt for Pipe Mounting)	02088-0071-0001	—
9, 10	LCD Meter Kit with Cover	03031-0193-0101	—
9	LCD Meter Kit without Cover	03031-0193-0103	A
8	Calibration Adapter	02088-0197-0001	A
5	Teflon Gaskets (package of 12)	02088-0078-0001	A
6	316 SST Weld Spud with Heat Isolator Groove	02088-0295-0003	—
6	316 SST Weld Spud	02088-0195-0001	—
7	316 SST Plug/Heat Sink	02088-0196-0001	A
11	Standard Terminal Block	03031-0332-0003	B
11	Transient Terminal Block	03031-0332-0004	B

(1) One spare part is recommended for every 25 transmitters in category A, and one spare part for every 50 transmitters in category B.

FIGURE 5-3. Replacement Parts for the Model 2090F.

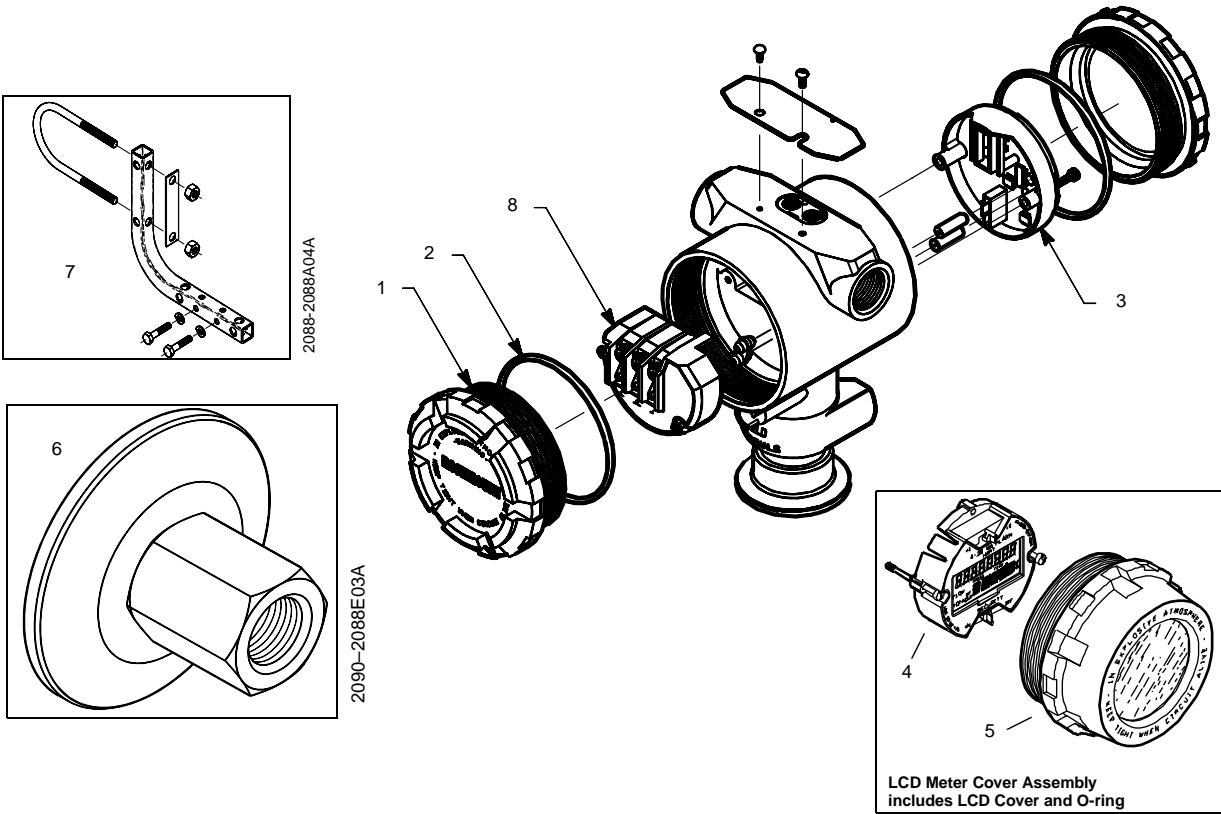

Item No.	Part Description	Part Number	Category <sup>(1)</sup>
1	<b>Smart Transmitters (Output Code S)</b> Electronics Cover (with O-ring)	03031-0292-0001	—
5	LCD Meter Cover Assembly	03031-0193-0002	B
2	O-rings	03031-0232-0001	B
3	Electronics Boards S Output (4–20 mA/Digital HART Protocol)	02088-0306-0002	A
3	S Output (NAMUR Compliant Operation)	02088-0306-0003	A
7	Optional Mounting Bracket (with 2-inch U-Bolt for Pipe Mounting)	02088-0071-0001	—
4, 5	LCD Meter Kit with Cover	03031-0193-0101	—
4	LCD Meter Kit without Cover	03031-0193-0103	A
6	Calibration Adapter, 1½ inch	02088-0197-0011	A
6	Calibration Adapter, 2 inch	02088-0197-0012	A
8	Standard Terminal Block	03031-0332-0003	B
8	Transient Terminal Block	03031-0332-0004	B

(1) One spare part is recommended for every 25 transmitters in category A, and one spare part for every 50 transmitters in category B.

**NOTE:** Sanitary clamp and gasket to be supplied by user.

**ORDERING INFORMATION**

TABLE 5-1. Model 2088 Typical Model Structure.

Model	Product Description (Select One)		
2088A	Absolute Pressure Transmitter		
2088G	Gage Pressure Transmitter		
Code	Range	Rangeability	
0 <sup>(1)</sup>	0–8 psi (0–6,89 to 0–552 mbar) Low power only	Output Code	Min.Span
1	0–30 psi (0–2 bar)	S	URL/20
2	0–150 psi (0–10,3 bar)	M	URL/10
3	0–800 psi (0–55,15 bar)		
4	0–4000 psi (0–275,8 bar)		
Code	Output		
M	1–5 V dc Low Power		
S	4–20 mA dc/Digital HART Protocol		
MATERIALS OF CONSTRUCTION			
Code	Process Connection	Isolating Diaphragm	Oil Fill
22 <sup>(2)</sup>	316 SST	316 SST	Silicone
33 <sup>(2)</sup>	Hastelloy C-276	Hastelloy C-276	Silicone
2B <sup>(2)</sup>	316 SST	316 SST	Inert <sup>(3)</sup>
3C <sup>(2)</sup>	Hastelloy C-276	Hastelloy C-276	Inert
Code	Process Connection		
A	½–14 NPT Female		
B	DIN 16288 G ½ Male		
C	RC ½ Female (PT ½ Female)		
D	M20 x 1.5 (CM20)		
Code	Conduit Thread		
1	½–14 NPT		
2	M20 x 1.5 (CM20)		
3	PG 13.5		
4	G ½ Female (PF ½ Female)		
Code	Remote Seal Connection		
S1	One Remote Seal (Select from Product Data Sheet 00813-0100-4016)		
Code	Options <sup>(4)</sup>		
M5	LCD Meter, scaled 0–100%		
M7	LCD Meter, special configuration		
B4	SST Mounting Bracket with SST Bolts		
S5	Assembly to Model 306 Integral Manifold (see PDS 00813-0100-4733 for ordering information)		
S1	One Diaphragm Seal (Select from Product Data Sheet 00813-0100-4016)		
C6	CSA Explosion-Proof, Intrinsic Safety, and Non-Incendive Approval		
I1	BASEEFA EEx ia IIC T5 (CENELEC) Intrinsic Safety Approval (Entity Concept)		
N1	BASEEFA Type N EX N IIC T5		
E4 <sup>(4)</sup>	JIS Explosion-Proof Approval		
E5	FM Explosion-Proof Approval		
E7 <sup>(4)</sup>	SAA Flame-Proof Certification		
E8	CESI/CENELEC Explosion-Proof Approval (available with analog output, Code A, only)		
ED	KEMA/CENELEC Explosion-Proof Approval (available with smart output, Code S, only)		
I5	FM Non-Incendive and Intrinsic Safety Approval (Entity Concept)		
I7 <sup>(4)</sup>	SAA Intrinsic Safety Certification		
K5	E5 and I5 Combination		
K6	CSA/CENELEC Explosion-Proof and Intrinsic Safety Approval		
N7 <sup>(4)</sup>	SAA Non-Incendive Certification		
P2	Cleaning for Special Service		
Q4	Calibration Data Sheet		
Q8	Material Traceability per DIN 3.1B		
T1	Transient Protection Terminal Block		
C4	Analog Output Levels Compliant with NAMUR Recommendation NE43, 27-June-1996 (Available with Output Code S only) <i>NOTE: NAMUR-Compliant operation is pre-set at the factory and cannot be changed to standard operation in the field.</i>		
CN	Analog Output Levels Compliant with NAMUR Recommendation NE43, 27-June-1996: Low Alarm Configuration <i>NOTE: NAMUR-Compliant operation is pre-set at the factory and cannot be changed to standard operation in the field.</i>		
C9	Software Configuration (Available with Output Code S only)		
<b>Typical Model Number: 2088G 1 S 22 A 1</b>			

(1) Range 0 is only available with low power output, 8 to 1 rangedown, stainless steel wetted parts and silicone oil fill fluid.

(2) Meets NACE material recommendations.

(3) Inert fill fluid not available with range 0 transmitters.

(4) Hazardous locations approvals not available for Model 2088 Smart Transmitter (Output Code S).

TABLE 5-2. Model 2090P Typical Model Structure.

Model	Product Description (Select One)		
2090PA	Absolute Pressure Transmitter		
2090PG	Gage Pressure Transmitter		
Code	Range	Rangeability	
1	0–30 psi (0–2 bar)	Output Code	Min.Span
2	0–150 psi (0–10,3 bar)	S	URL/20
3 <sup>(1)</sup>	0–300 psi (0–20,7 bar)		
Code	Output		
S	4–20 mA dc/Digital HART Protocol		
MATERIALS OF CONSTRUCTION			
Code	Process Connection	Isolating Diaphragm	Oil Fill
22	316 SST	316 SST	Silicone
Code	Process Connection		
A	No Weld Spud, includes <i>Teflon</i> Gasket		
B	316 SST Weld Spud, <i>Teflon</i> Gasket		
C	316 SST Weld Spud with Heat Isolator Groove		
Code	Conduit Thread		
1	½–14 NPT		
2	M20 x 1.5 (CM20)		
3	PG 13.5		
Code	Options		
M5	LCD Meter, scaled 0–100%		
M7	LCD Meter, special configuration		
B4	SST Mounting Bracket with SST Bolts		
S5	Assembly to Model 306 Integral Manifold (see PDS 00813-0100-4733 for ordering information)		
C6	CSA Explosion-Proof, Intrinsic Safety, and Non-Incendive Approval		
I1	BASEEFA EEx ia IIC T5 (CENELEC) Intrinsic Safety Approval (Entity Concept)		
N1	BASEEFA Type N EX N IIC T5		
E5	FM Explosion-Proof Approval		
E8	CESI/CENELEC Explosion-Proof Approval (available with analog output, Code A, only)		
ED	KEMA/CENELEC Explosion-Proof Approval (available with smart output, Code S, only)		
I5	FM Non-Incendive and Intrinsic Safety Approval (Entity Concept)		
K5	E5 and I5 Combination		
K6	CSA/CENELEC Explosion-Proof and Intrinsic Safety Approval		
P2	Cleaning for Special Service		
Q4	Calibration Data Sheet		
Q8	Material Traceability per DIN 3.1B		
T1	Transient Protection Terminal Block		
<b>Typical Model Number: 2090PG 2 S 22 B 1</b>			

(1) Range 3 minimum span: 0–40 psi.

## Rosemount Model 2088/2090 Pressure Transmitters

TABLE 5-3. Model 2090F Typical Model Structure.

Model	Product Description (Select One)		
2090FA	Sanitary Absolute Pressure Transmitter		
2090FG	Sanitary Gage Pressure Transmitter		
Code	Range	Rangeability	
1	0–30 psi (0–2 bar)	Output Code	Min.Span
2	0–150 psi (0–10,3 bar)	S	URL/20
3 <sup>(1)</sup>	0–300 psi (0–20,7 bar)		
Code	Output		
S	4–20 mA dc/Digital HART Protocol		
MATERIALS OF CONSTRUCTION			
Code	Process Connection	Isolating Diaphragm	Oil Fill
2D	316 SST	316 SST	Neobee
Code	Process Connection		
E	1½-inch <i>Tri-Clamp</i> Connection		
F	2-inch <i>Tri-Clamp</i> Connection		
Code	Conduit Thread		
1	½–14 NPT		
2	M20 x 1.5 (CM20)		
3	PG 13.5		
Code	Options		
M5	LCD Meter, scaled 0–100%		
M7	LCD Meter, special configuration		
B4	SST Mounting Bracket with SST Bolts		
S5	Assembly to Model 306 Integral Manifold (see PDS 00813-0100-4733 for ordering information)		
C6	CSA Explosion-Proof, Intrinsic Safety, and Non-Incendive Approval		
I1	BASEEFA EEx ia IIC T5 (CENELEC) Intrinsic Safety Approval (Entity Concept)		
N1	BASEEFA Type N EX N IIC T5		
E5	FM Explosion-Proof Approval		
E8	CESI/CENELEC Explosion-Proof Approval (available with analog output, Code A, only)		
ED	KEMA/CENELEC Explosion-Proof Approval (available with smart output, Code S, only)		
I5	FM Non-Incendive and Intrinsic Safety Approval (Entity Concept)		
K5	E5 and I5 Combination		
K6	CSA/CENELEC Explosion-Proof and Intrinsic Safety Approval		
P2	Cleaning for Special Service		
Q4	Calibration Data Sheet		
Q8	Material Traceability per DIN 3.1B		
T1	Transient Protection Terminal Block		
<b>Typical Model Number: 2090FG 2 S 2D E 1</b>			

(1) Range 3 minimum span: 0–40 psi.

### NOTE

One product manual is included per shipment.

## CALIBRATION

All transmitters are factory calibrated to customer's specified range. If calibration is not specified, transmitters are calibrated at maximum range. Calibration is at ambient temperature.

## TAGGING

Transmitter are tagged, at no charge, in accordance with customer requirements. All tags are stainless steel. The standard tag is wired to the transmitter. Tag character height is ⅜-inch (0,318 cm). A permanently attached tag is available upon request.



## LCD Meter

### LCD METER

The LCD meter provides local indication of the output, and abbreviated diagnostic messages governing transmitter operation. The meter is located on the electronics module side of the transmitter, maintaining direct access to the signal terminals. An extended cover is required to accommodate the meter.

The new meter features a two-line display that accommodates five digits for reporting the process variable on the top line, and six characters for displaying engineering units on the bottom line. The meter uses both lines to display diagnostic messages. You can configure the meter to display the following information:

- Engineering Units
- Percent of Range
- User-Configurable LCD Scale
- Alternating between any two of the above

### SAFETY MESSAGES

Procedures and instructions in this section may require special precautions to ensure the safety of the personnel performing the operations. Information that raises potential safety issues is indicated by a warning symbol (⚠). Refer to the following safety messages before performing an operation preceded by this symbol.

### Warnings (⚠)

#### **WARNING**

##### **Explosions can result in death or serious injury.**

- Do not remove the transmitter covers in explosive environments when the circuit is alive.
- Transmitter covers must be fully engaged to meet explosionproof requirements.
- Before connecting a communicator in an explosive atmosphere, make sure the instruments in the loop are installed in accordance with intrinsically safe or nonincendive field wiring practices.

## CUSTOM METER CONFIGURATION

The user-configurable scale is a feature that enables the LCD meter to display flow, level, or custom pressure units. The meter can be configured using a Model 275 HART Communicator or AMS.

The user-configurable scale feature can define:

- decimal point position
- upper range values
- lower range values
- engineering units
- transfer function

To configure the meter using AMS, click the **LOCAL DISPLAY** tab on the **CONFIGURATION PROPERTIES** screen. To configure the meter with a HART communicator, perform the following procedure:



1. Connect the communicator to the transmitter. Before connecting a communicator in an explosive atmosphere, make sure the instruments in the loop are installed according to intrinsically safe or nonincendive field wiring practices.
2. From the **ONLINE** screen, select *1 Device Setup, 3 Basic Setup, 7 Meter Options, 2 Custom Meter Setup*.
3. To specify decimal point position:
  - a. Select *1 Sel dec pt pos*. Choose the decimal point representation that will provide the most accurate output for your application. For example, when outputting between 0 and 75 GPM, choose *XX.XXX*.
  - b. Go to step 8.
4. To specify a custom upper range value:
  - a. Select *2 CM Upper Value*. Type the value that you want the transmitter to read at the 20 mA point.
  - b. Go to step 8.
5. To specify a custom lower range value:
  - a. Select *3 CM Lower Value*. Type the value that you want the transmitter to read at the 4 mA point.
  - b. Go to step 8.
6. To define custom units:
  - a. Select *4 CM Units*. Enter the custom units (five characters maximum) that you want the meter to display.
  - b. Go to step 8.
7. To choose the transmitter transfer function for the meter:
  - a. Select *5 CM xfer fnct*. Enter the transmitter transfer function for the meter. Select *sq root* to display flow units. The custom meter transfer function is independent of the analog output transfer function.
8. Select **F2 SEND** to upload the configuration to the transmitter.

FIGURE A-1. Exploded View of the Transmitter with Optional LCD Meter.

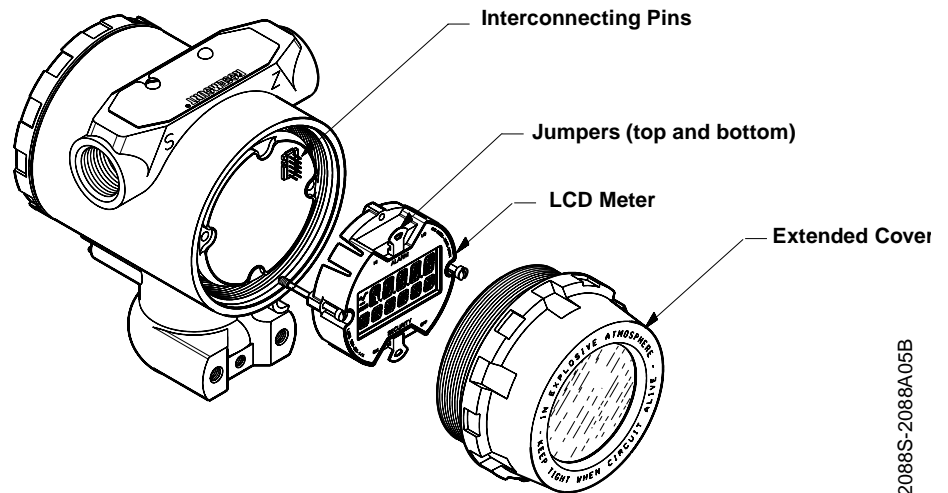

2088S-2088A05B

## DIAGNOSTIC MESSAGES

In addition to the output, the LCD meter displays abbreviated operation, error, and warning messages for troubleshooting the transmitter. Messages appear according to their priority, with normal operating messages appearing last. To determine the cause of a message, use a Model 275 HART Communicator to further interrogate the transmitter. A description of each LCD diagnostic message follows.

### Error

Error messages appear on the LCD meter display to inform you of serious problems effecting the operation of the transmitter. The meter displays an error message until the error condition is corrected, and the analog output is driven to the specified alarm level. No other transmitter information is displayed during an alarm condition.

#### FAIL

The transmitter CPU board and the sensor module are incompatible.

#### FAIL MODULE

The sensor module is disconnected or is malfunctioning. Verify that the sensor module ribbon cable is connected to the back of the electronics board. If the ribbon cable is not disconnected, there is a problem within the sensor module. Possible sources of problems include:

- Pressure or temperature updates are not being received in the sensor module.
- A non-volatile memory fault that will effect transmitter operation has been detected in the module by the memory verification routine.

#### FAIL ELECT

The transmitter electronics module is malfunctioning. Possible causes include:

- Internal fault
- A non-volatile memory fault that will effect transmitter operation has been detected in the module by the memory verification routine

Neither problem is repairable; the electronics board must be replaced.

### **FAIL CONFIG**

A non-volatile memory fault has been detected in the transmitter memory by the memory verification routine. The memory fault is in a location that could effect transmitter operation, and is user-accessible. To correct this problem, use a Model 275 HART Communicator to interrogate and reconfigure the appropriate portion of the transmitter memory.

## **Warnings**

Warnings appear on the LCD meter display to alert you of user-repairable problems with the transmitter, or current transmitter operations. Warnings appear alternately with other transmitter information until the warning condition is corrected or the transmitter completes the operation that triggered the warning message.

### **PRESS LIMIT**

The process variable read by the transmitter is outside of sensor range limits.

### **CURR FIXED**

The transmitter is in multidrop mode. The analog output is not tracking pressure changes.

### **CURR SATURD**

The pressure read by the module is outside of the specified range, and the analog output has been driven to saturation levels (see **Failure Mode and Security Jumpers** on page 3-12).

### **LOOP TEST**

A loop test is in progress. During a loop test or 4–20 mA trim, the analog output is set to a fixed value. The meter display alternates between the current selected in milliamps and “LOOP TEST.”

### **XMTR INFO**

A non-volatile memory fault has been detected in the transmitter memory by the memory verification routine. The memory fault is in a location containing transmitter information. To correct this problem, use a Model 275 HART Communicator to interrogate and reconfigure the appropriate portion of the transmitter memory. This warning does not effect the transmitter operation.

## **Operation**

Normal operation messages appear on the LCD meter to confirm actions or inform you of transmitter status. Operation messages are displayed with other transmitter information, and warrant no action to correct or alter the transmitter settings.

### **ZERO PASS**

The zero value, set with the local zero adjustment button, has been accepted by the transmitter, and the output should change to 4 mA.

### **ZERO FAIL**

The zero value, set with the local zero adjustment button, exceeds the maximum rangedown allowed for a particular range, or the pressure sensed by the transmitter exceeds the sensor limits.

### **SPAN PASS**

The span value, set with the local span adjustment button, has been accepted by the transmitter, and the output should change to 20 mA.

**LOCAL DSBLD**

This message appears during reranging with the integral zero and span buttons and indicates that the transmitter local zero and span adjustments have been disabled. The adjustments may have been disabled by the transmitter security jumper on the transmitter circuit board or through software commands from the Model 275. Refer to **Failure Mode and Security Jumpers** on page 3-12 for information on the position of the security jumper, and for information on the software lockout.

**WRITE PROTCT**

The write protect (SECURITY) jumper is set to disable changes to the transmitter configuration data. Refer to **Failure Mode and Security Jumpers** on page 3-12 for more information on the security jumper.



# Model 275 HART Communicator

## OVERVIEW

This appendix provides basic communicator information on the Model 275 HART Communicator when used with Models 2088, 2090P, or 2090F Smart Pressure Transmitters.

Included in this appendix are a menu tree, a table of fast key sequences, and information on using the HART communicator.

For more complete information on the HART Communicator, refer to the HART Communicator Product Manual 00809-0100-4275.

This brief appendix will familiarize you with the HART Communicator but is not meant to replace the HART Communicator product manual.

## SAFETY MESSAGES

Instructions and procedures in this section may require special precautions to ensure the safety of the personnel performing the operations. Information that raises potential safety issues is indicated by a warning symbol (⚠). Please refer to the following safety messages before performing an operation preceded by this symbol.

### Warnings

#### **⚠WARNING**

**Explosions could result in death or serious injury:**

- Do not make connections to the serial port or NiCad recharger jack in an explosive atmosphere.
- Before connecting a HART-based communicator in an explosive atmosphere, make sure the instruments in the loop are installed in accordance with intrinsically safe or non-incendive field wiring practices.
- Both transmitter covers must be fully engaged to meet explosion-proof requirements.

#### **⚠WARNING**

**High voltage that may be present on leads could cause electrical shock:**

- Avoid contact with leads and terminals.

FIGURE B-1. HART Communicator Menu Tree for the Model 2088 Smart.

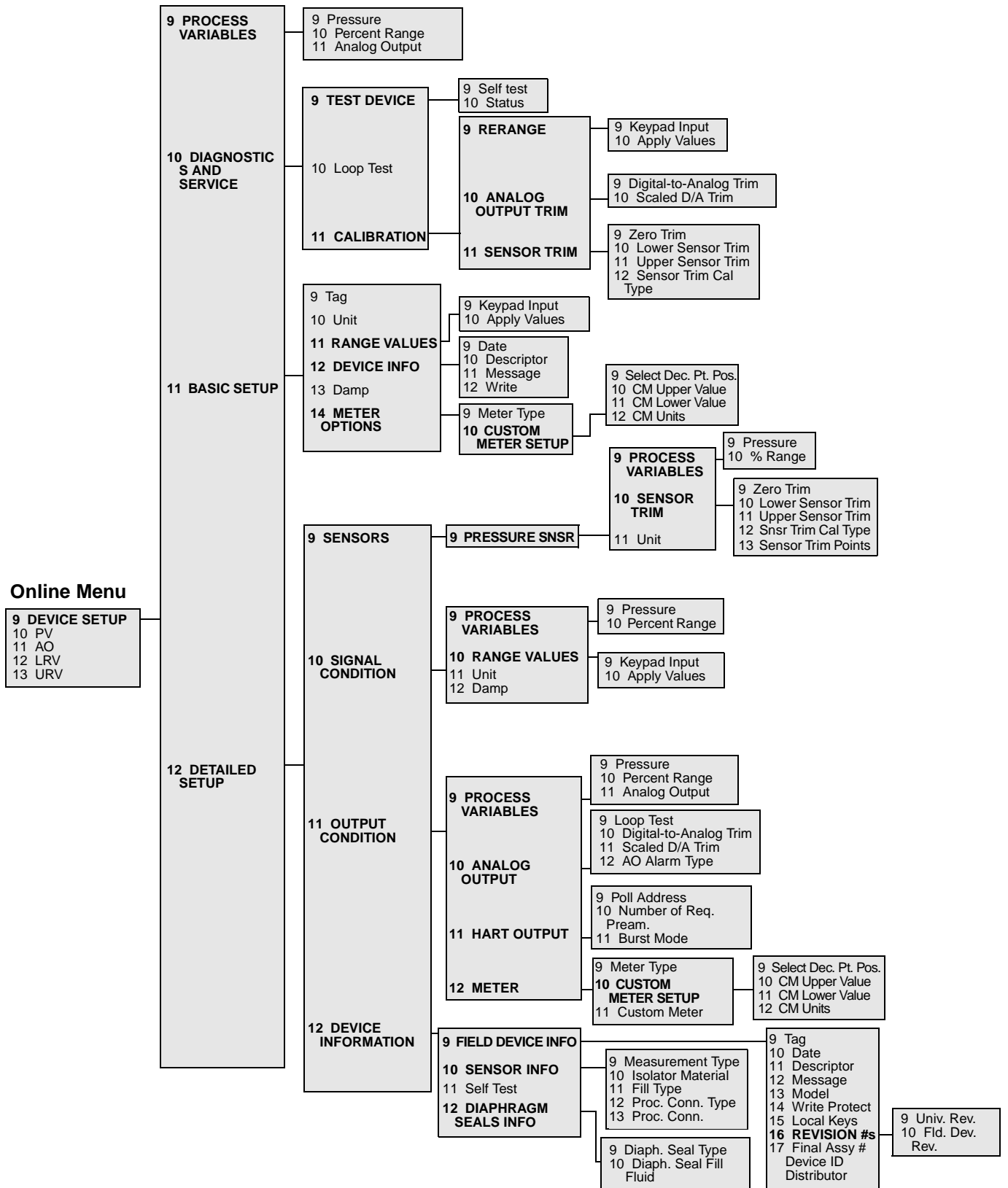



TABLE B-1. HART Fast Key Sequences for the Model 2088S.

Function	HART Communicator Fast Key Sequences
Analog Output	3
Analog Output Alarm	1, 4, 3, 2, 4
Burst Mode Control	1, 4, 3, 3, 3
Burst Operation	1, 4, 3, 3, 4
Calibration	1, 2, 3
Damping	1, 3, 5
Date	1, 3, 4, 1
Descriptor	1, 3, 4, 2
Digital To Analog Trim (4–20 mA Output)	1, 2, 3, 2, 1
Disable Local Span/Zero Adjustment	1, 4, 4, 1, 7
Field Device Info	1, 4, 4, 1
Keypad Input	1, 2, 3, 1, 1
Loop Test	1, 2, 2
Lower Range Value	4, 1
Lower Sensor Trim	1, 2, 3, 3, 2
Message	1, 3, 4, 3
Meter Type	1, 3, 6, 1
Number of Requested Preambles	1, 4, 3, 3, 2
Output Trim	1, 2, 3, 2
Percent Range	1, 1, 2
Poll Address	Left Arrow, 5, 1
Pressure	2
Range Values	1, 3, 3
Rerange	1, 2, 3, 1
Scaled D/A Trim (4–20 mA Output)	1, 2, 3, 2, 2
Self Test (Transmitter)	1, 2, 1, 1
Sensor Info	1, 4, 4, 2
Sensor Trim (Full Trim)	1, 2, 3, 3
Sensor Trim Points	1, 2, 3, 3, 5
Status	1, 2, 1, 2
Tag	1, 3, 1
Transmitter Security (Write Protect)	1, 3, 4, 4
Units (Process Variable)	1, 3, 2
Upper Range Value	5
Upper Sensor Trim	1, 2, 3, 3, 3
Zero Trim	1, 2, 3, 3, 1

## CONNECTIONS AND HARDWARE

 The HART Communicator Model 275 can interface with a transmitter from the control room, the instrument site, or any wiring termination point in the loop through the rear connection panel as shown in Figure B-2. To communicate, connect the HART Communicator in parallel with the instrument or load resistor. The connections are non-polarized. Avoid contact with leads and terminals. Do not make connections to the serial port or NiCad recharger jack in an explosive atmosphere. Before connecting the HART Communicator in an explosive atmosphere, make sure the instruments in the loop are installed in accordance with intrinsically safe or nonincendive field wiring practices. Both transmitter covers must be fully engaged to meet explosion proof requirements.

FIGURE B-2. Rear Connection Panel with Optional NiCad Recharger Pack.



275-008AB

### NOTE

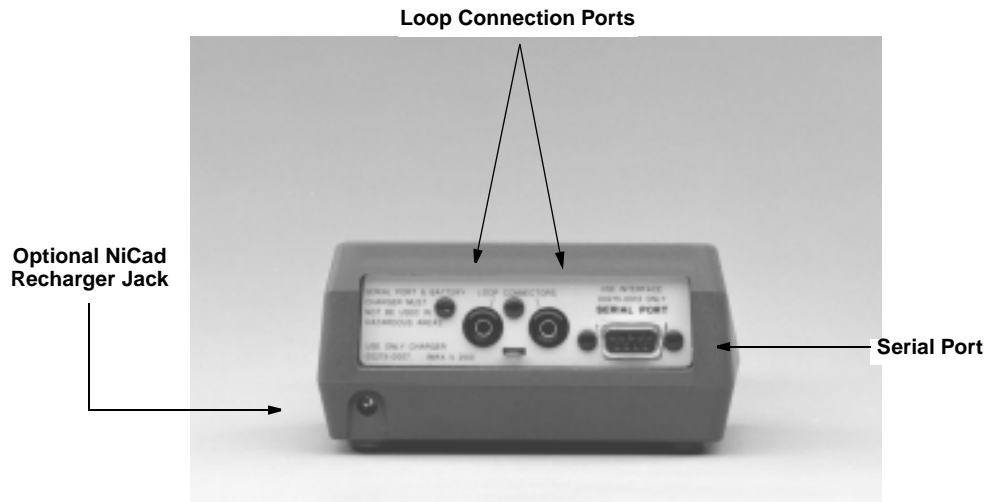
The HART Communicator needs a minimum of 250 ohms resistance in the loop to function properly. The HART Communicator does not measure loop current directly.

FIGURE B-3. Bench Hook-up (4–20 mA Transmitters).

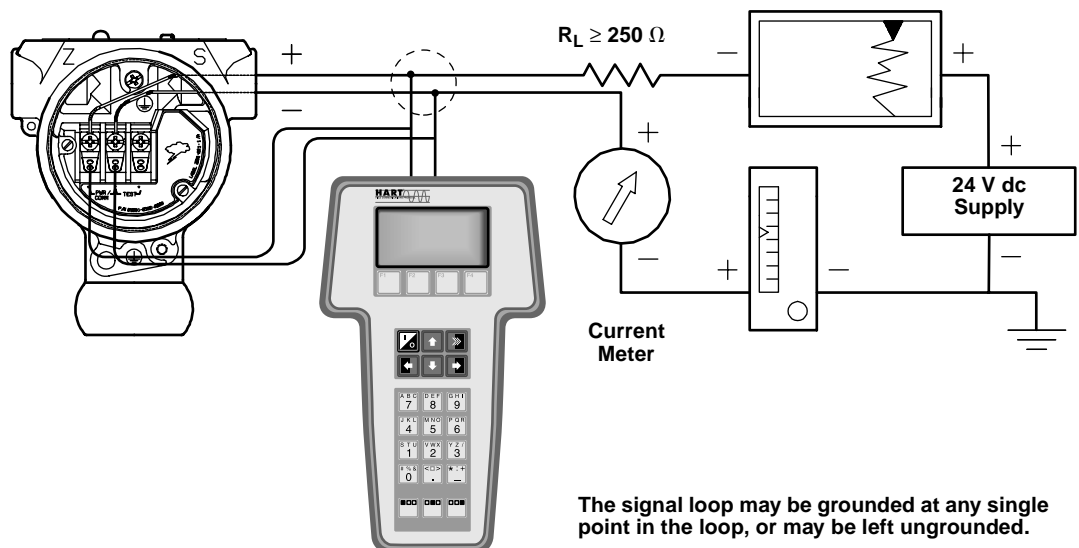

2088S-2088C02C

## COMMUNICATOR KEYS

The keys of the HART Communicator include action, function, alphanumeric, and shift keys

FIGURE B-4. The HART Communicator.

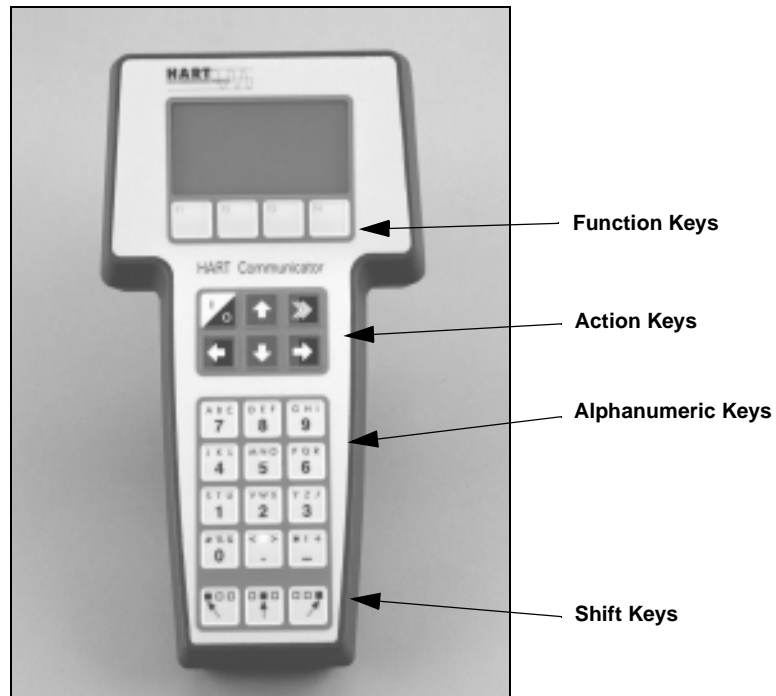

275-011AB

### Action Keys

As shown in Figure B-4, the action keys are the six blue, white, and black keys located above the alphanumeric keys. The function of each key is described as follows:

#### ON/OFF Key

Use this key to power the HART Communicator. When the communicator is turned on, it searches for a transmitter on the 4–20 mA loop. If a device is not found, the communicator displays the message, “No Device Found. Press OK.”

If a HART-compatible device is found, the communicator displays the Online Menu with device ID and tag.

#### Directional Keys

Use these keys to move the cursor up, down, left, or right. The right arrow key also selects menu options, and the left arrow key returns to the previous menu.

#### HOT Key

Use this key to quickly access important, user-selectable options when connected to a HART-compatible device. Pressing the Hot Key turns the HART Communicator on and displays the Hot Key Menu. See Customizing the Hot Key Menu in the HART Communicator manual for more information.

**Function Keys**



Use the four software-defined function keys, located below the LCD, to perform software functions. On any given menu, the label appearing above a function key indicates the function of that key for the current menu. As you move among menus, different function key labels appear over the four keys. For example, in menus providing access to on-line help, the **HELP** label may appear above the F1 key. In menus providing access to the Online Menu, the **HOME** label may appear above the F3 key. Simply press the key to activate the function. See your HART Communicator manual for details on specific function key definitions.

**Alphanumeric and Shift Keys**

The alphanumeric keys, see Figure B-5 perform two functions: the fast selection of menu options and data entry.

FIGURE B-5. HART Communicator Alphanumeric and Shift Keys.

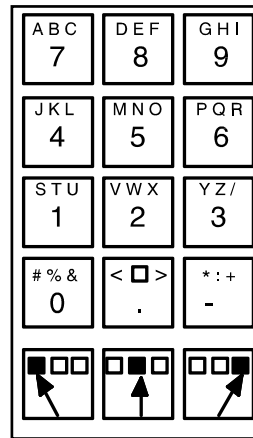

2088S-275-0383A

**Data Entry**

Some menus require data entry. Use the alphanumeric and shift keys to enter all alphanumeric information into the HART Communicator. If you press an alphanumeric key alone from within an edit menu, the bold character in the center of the key appears. These large characters include the numbers zero through nine, the decimal point (.), and the dash symbol (—).

To enter an alphabetic character, first press the shift key that corresponds to the position of the letter you want on the alphanumeric key. Then press the alphanumeric key. For example, to enter the letter R, first press the right shift key, then the “6” key, see Figure B-6. Do not press these keys simultaneously, but one after the other.

FIGURE B-6. Data Entry Key Sequence.

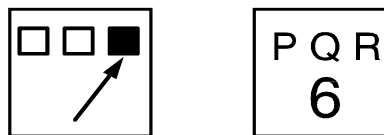

2088S-275-0352A, 0343A

## Fast Key Sequences

*HART Fast Key Sequences* provide quick on-line access to transmitter variables and functions. Instead of stepping your way through the menu structure using the action keys, you can press a HART fast key sequence to move from the Online Menu to the desired variable or function. On-screen instructions guide you through the rest of the screens.

## Conventions

The fast key sequences for the Model 275 use the following conventions for their identification:

**1 through 9**—Refer to the keys located directly below the dedicated keypad.

**Left Arrow**—Refers to the left arrow directional key.

## Example

HART fast key sequences are made up of the series of numbers corresponding to the individual options in each step of the menu structure. For example, from the Online Menu you can change the **Date**. Following the menu structure, press 1 to reach **Device Setup**, press 3 for **Basic Setup**, press 4 for **Device Info**, press 5 for **Date**. The corresponding HART fast key sequence is 1,3,4,5.

HART fast keys are operational only from the Online Menu. If you use them consistently, you will need to return to the Online Menu by pressing **HOME** (F3) when it is available. If you do not start at the Online Menu, the HART fast key sequences will not function properly.

Use Table B-1, an alphabetical listing of every on-line function, to find the corresponding HART fast key sequences. These codes are applicable only to Model 2088S transmitters and the HART Communicator.

## MENUS AND FUNCTIONS

The HART Communicator is a menu driven system. Each screen provides a menu of options that can be selected as outlined above, or provides direction for input of data, warnings, messages, or other instructions.

## Main Menu

When the HART Communicator is turned on, one of two menus will appear. If the HART Communicator is connected to an operating loop, the communicator will find the device and display the Online Menu (see below). If it is not connected to a loop, the communicator will indicate that no device was found. When you press OK (F4), it will display the Main menu.

The *Main Menu* provides the following options:

- *Offline*—saves or retrieves transmitter configuration information.
- *Online*—connects the communicator to a compatible device.

---

### NOTE

Online communication with the transmitter automatically loads the current transmitter data to the HART Communicator. Changes in online data are made active by pressing SEND (F2). The transfer function is used only for off-line data retrieval and sending.

---

- *Frequency Device*—The Frequency Device option displays the frequency output and corresponding pressure output of current-to-pressure transmitters.
- *Utility*—The Utility option provides access to the contrast control for the HART Communicator LCD screen and to the autopoll setting used in multidrop applications.

Once selecting a main menu option, the HART Communicator provides the information you need to complete the operation. If further details are required, consult the HART Communicator manual.

## Online Menu

The *Online Menu* can be selected from the main menu as outlined above, or it may appear automatically if the HART Communicator is connected to an active loop and can detect an operating transmitter.

---

### NOTE

The main menu can be accessed from the Online Menu. Press the left arrow action key to deactivate the on-line communication with the transmitter and to activate the main menu options.

---

When configuration variables are reset in the on-line mode, the new settings are not activated until the data are sent to the transmitter. Press SEND (F2) when it is activated to update the process variables of the transmitter.

On-line mode is used for direct evaluation of a particular meter, reconfiguration, changing parameters, maintenance, and other functions.

## Diagnostic Messages

The following pages contain a list of messages used by the HART Communicator (HC) and their corresponding descriptions.

Variable parameters within the text of a message are indicated with *<variable parameter>*.

Reference to the name of another message is identified by *[another message]*.

Message	Description
<b>Add item for ALL device types or only for this ONE device type.</b>	Asks the user whether the hot key item being added should be added for all device types or only for the type of device that is connected.
<b>Command Not Implemented</b>	The connected device does not support this function.
<b>Communication Error</b>	Either a device sends back a response indicating that the message it received was unintelligible, or the HC cannot understand the response from the device.
<b>Configuration memory not compatible with connected device</b>	The configuration stored in memory is incompatible with the device to which a transfer has been requested.
<b>Device Busy</b>	The connected device is busy performing another task.
<b>Device Disconnected</b>	Device fails to respond to a command.
<b>Device write protected</b>	Device is in write-protect mode. Data can not be written.
<b>Device write protected. Do you still want to shut off?</b>	Device is in write-protect mode. Press YES to turn the HC off and lose the unsent data.
<b>Display value of variable on hotkey menu?</b>	Asks whether the value of the variable should be displayed adjacent to its label on the hotkey menu if the item being added to the hotkey menu is a variable.
<b>Download data from configuration memory to device</b>	Prompts user to press SEND softkey to initiate a memory to device transfer.
<b>Exceed field width</b>	Indicates that the field width for the current arithmetic variable exceeds the device- specified description edit format.
<b>Exceed precision</b>	Indicates that the precision for the current arithmetic variable exceeds the device- specified description edit format.
<b>Ignore next 50 occurrences of status?</b>	Asked after displaying device status. Softkey answer determines whether next 50 occurrences of device status will be ignored or displayed.
<b>Illegal character</b>	An invalid character for the variable type was entered.
<b>Illegal date</b>	The day portion of the date is invalid.
<b>Illegal month</b>	The month portion of the date is invalid.
<b>Illegal year</b>	The year portion of the date is invalid.
<b>Incomplete exponent</b>	The exponent of a scientific notation floating point variable is incomplete.
<b>Incomplete field</b>	The value entered is not complete for the variable type.
<b>Looking for a device</b>	Polling for multidropped devices at addresses 1–15.
<b>Mark as read only variable on hotkey menu?</b>	Asks whether the user should be allowed to edit the variable from the hotkey menu if the item being added to the hotkey menu is a variable.
<b>No device configuration in configuration memory</b>	There is no configuration saved in memory available to reconfigure off-line or transfer to a device.
<b>No Device Found</b>	Poll of address zero fails to find a device, or poll of all addresses fails to find a device if auto-poll is enabled.
<b>No hotkey menu available for this device.</b>	There is no menu named "hotkey" defined in the device description for this device.
<b>No offline devices available.</b>	There are no device descriptions available to be used to configure a device offline.
<b>No simulation devices available.</b>	There are no device descriptions available to simulate a device.
<b>No UPLOAD_VARIABLES in ddl for this device</b>	There is no menu named "upload_variables" defined in the device description for this device. This menu is required for offline configuration.
<b>No Valid Items</b>	The selected menu or edit display contains no valid items.
<b>OFF KEY DISABLED</b>	Appears when the user attempts to turn the HC off before sending modified data or before completing a method.
<b>Online device disconnected with unsent data. RETRY or OK to lose data.</b>	There is unsent data for a previously connected device. Press RETRY to send data, or press OK to disconnect and lose unsent data.

## Rosemount Model 2088/2090 Pressure Transmitters

Message	Description
<b>Out of memory for hotkey configuration. Delete unnecessary items.</b>	There is no more memory available to store additional hotkey items. Unnecessary items should be deleted to make space available.
<b>Overwrite existing configuration memory</b>	Requests permission to overwrite existing configuration either by a device-to-memory transfer or by an offline configuration. User answers using the softkeys.
<b>Press OK...</b>	Press the OK softkey. This message usually appears after an error message from the application or as a result of HART communications.
<b>Restore device value?</b>	The edited value that was sent to a device was not properly implemented. Restoring the device value returns the variable to its original value.
<b>Save data from device to configuration memory</b>	Prompts user to press SAVE softkey to initiate a device-to-memory transfer.
<b>Saving data to configuration memory.</b>	Data is being transferred from a device to configuration memory.
<b>Sending data to device.</b>	Data is being transferred from configuration memory to a device.
<b>There are write only variables which have not been edited. Please edit them.</b>	There are write-only variables which have not been set by the user. These variables should be set or invalid values may be sent to the device.
<b>There is unsent data. Send it before shutting off?</b>	Press YES to send unsent data and turn the HC off. Press NO to turn the HC off and lose the unsent data.
<b>Too few data bytes received</b>	Command returns fewer data bytes than expected as determined by the device description.
<b>Transmitter Fault</b>	Device returns a command response indicating a fault with the connected device; the transmitter is in alarm.
<b>Units for &lt;variable label&gt; has changed. Unit must be sent before editing, or invalid data will be sent.</b>	The engineering units for this variable have been edited. Send engineering units to the device before editing this variable.
<b>Unsent data to online device. SEND or LOSE data</b>	There is unsent data for a previously connected device which must be sent or thrown away before connecting to another device.
<b>Use up/down arrows to change contrast. Press DONE when done.</b>	Gives direction to change the contrast of the HC display.
<b>Value out of range</b>	The user-entered value is either not within the range for the given type and size of variable or not within the min/max specified by the device.
<b>&lt;message&gt; occurred reading/writing &lt;variable label&gt;</b>	Either a read/write command indicates too few data bytes received, transmitter fault, invalid response code, invalid response command, invalid reply data field, or failed pre- or post-read method; or a response code of any class other than SUCCESS is returned reading a particular variable.
<b>&lt;variable label&gt; has an unknown value. Unit must be sent before editing, or invalid data will be sent.</b>	A variable related to this variable has been edited. Send related variable to the device before editing this variable.



# Model 2088 Low Power Option

## OVERVIEW

The information in this appendix is specific to the Model 2088 Low Power Pressure Transmitter. This transmitter outputs a 1–5 V dc signal proportional to input pressure. The Low Power Option is designated with Output Code M.

## SAFETY MESSAGES

Instructions and procedures in this section may require special precautions to ensure the safety of the personnel performing the operations. Information that raises potential safety issues is indicated by a warning symbol (⚠). Power and signal connections are made by removing the housing cover on the field terminal side of the transmitter housing.

### ⚠ WARNING

#### Explosions could result in death or serious injury:

- Do not remove the transmitter cover in explosive atmospheres when the circuit is alive.
- Verify that the operating atmosphere of the transmitter is consistent with the appropriate hazardous locations certifications.
- Both transmitter covers must be fully engaged to meet explosionproof requirements.

### ⚠ WARNING

#### Failure to follow these installation guidelines could result in death or serious injury:

- Make sure only qualified personnel perform the installation.

## COMMISSIONING THE TRANSMITTER

The Model 2088 Analog Pressure Transmitter can be continuously adjusted to spans between maximum span and  $\frac{1}{10}$  of maximum span<sup>(1)</sup>. Transmitter linearity information is programmed into the microprocessor at the factory; linearity adjustment is not necessary in the field.

## INSTALLATION

To install the low power analog transmitter, follow the procedures in Section 3 Installation. The housing of the analog transmitter is slightly different from that of the smart transmitter. Dimensional drawings of the analog transmitter are provided in Figure C-1.

(1) For Model 2088 Range 0, minimum span is 1 psi.

Figure C-1. Low Power Analog Transmitter Dimensional Drawings.

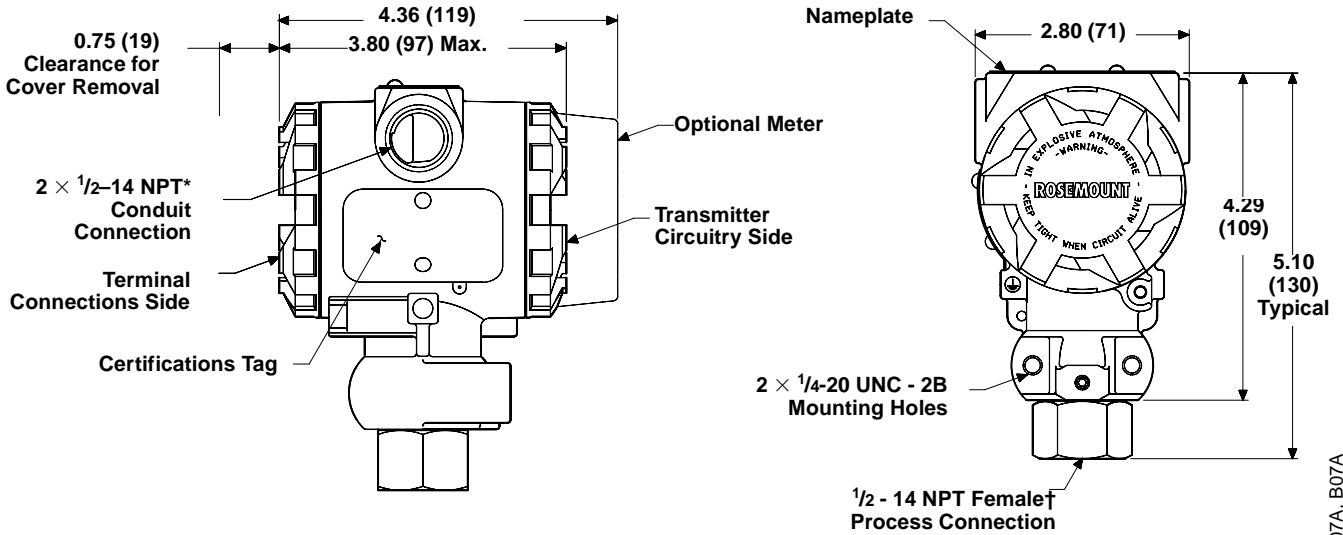

\* M20 × 1.5 Female (CM20), PG 13.5, and G 1/2 Female (PF 1/2), also available as options.  
 †DIN 16288 G 1/2 Male, RC 1/2 Female (PT 1/2+) and M20 × 1.5 Male [CM20], also available as options.  
 Dimensions are in in. (mm).

2088-2088A07A, B07A

## WIRING

Power and signal connections are made by removing the housing cover on the field terminal side of the transmitter housing.

### ⚠ CAUTION

Do not connect the positive lead from the power supply to the “+” V out termination on the terminal side of the electronic housing. This may result in an erroneous output and may damage the output board, the power supply, or both.

Connect the positive lead from the power supply to the (+) PWR terminal and the negative lead to the (–) terminal. Connect the positive lead of the readout device or A/D converter to the “Vout” terminal and the negative lead to the “–” terminal. Shielded pair wiring is recommended and all common leads should be connected to the same ground, see Figure C-2.

Figure C-2. Field Wiring for Model 2088—Low Power Option Code M.

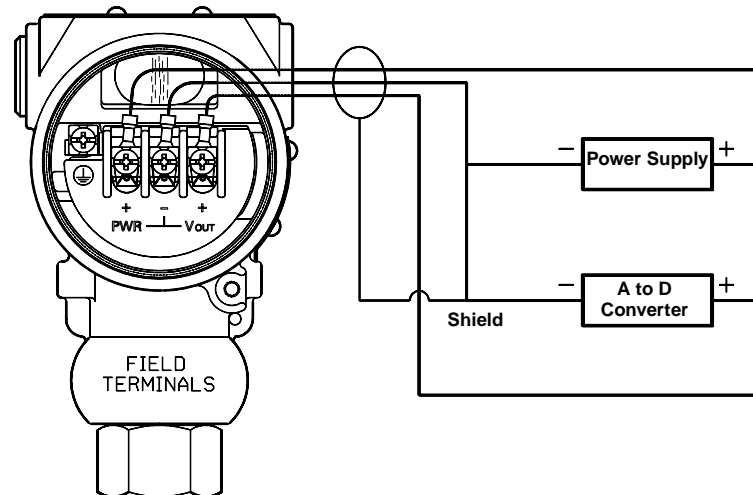

2088-B02F

## CALIBRATION

The procedure for calibrating the Model 2088 is different from that of other pressure transmitters and takes some time to become accustomed to. However, this method of calibration is considerably faster than other calibration methods. In addition, there is no interaction between the zero and span adjustments.

An important feature of this design is that the potentiometer is an active part of the circuit only during calibration. The potentiometer is removed from the active circuit when the switch is placed in the “RUN” position. The design that allows deactivation of the potentiometer eliminates the temperature drift and stability shifts often associated with common potentiometers.

## Selector Switch

The selector switch is labeled “Z” (Zero), “RUN,” and “S” (Span). The switch is set to the “RUN” position at the factory and should remain there under normal operation. The microprocessor will not accept a new value from the switch until you adjust the potentiometer. Therefore, in case you accidentally change the switch position, you can return it to the “RUN” position without affecting calibration if you do not turn the potentiometer.

### ⚠ CAUTION

The selector switch must be returned to the “RUN” position after setting the proper calibration. Failure to return the switch to the “RUN” position will result in erroneous transmitter output during an overpressure condition.

## Potentiometer Adjustment

The potentiometer is marked “DN” (Down), “FINE,” and “UP.” The coarse adjustment regions are at each end, and a fine adjustment region is in the center. The output of the transmitter increases or decreases automatically when the potentiometer is placed in the coarse adjustment regions. The longer the potentiometer is held in the coarse adjustment region, the faster the rate of change in output.

### CAUTION

The potentiometer is a  $\frac{3}{4}$ -turn device and has a mechanical stop to prevent full rotation. Do not exert large twisting forces against the mechanical stop or damage will result.

### NOTE

When the transmitter output is saturated, the potentiometer may appear to have no effect on the transmitter calibration because the microprocessor is adjusting the calibration, but the current-limiting circuitry is maintaining the output at the saturation levels. Place the potentiometer in the coarse-adjust region and wait several seconds for the output to change.

---

## Setting the Zero

### CAUTION

Do not contact meter leads from either test terminal on the output board to case ground. Contact can result in the maximum current from the power supply flowing through the test meter and may blow the test meter fuse, or damage the test meter or transmitter.



Setting the zero point of the transmitter involves applying pressure and adjusting the potentiometer accordingly. To set the zero point of the transmitter, use the following procedure.

1. If the transmitter does not have a readout device, attach a voltmeter. Terminals for monitoring or calibrating are located in two separate locations. The first is in the terminal compartment. Connect the positive lead to the “-” terminal. When calibrating directly from the output board, connect the positive lead of the voltmeter to the terminal labeled “+ TEST” and the negative lead to the “- TEST” terminal, see Figure C-3.
2. Ensure that the selector switch is in the “RUN” position. Apply the pressure to which the zero point will be calibrated.
3. Set the selector switch to “Z.”
4. Using the potentiometer, adjust the transmitter output until the readout device reads the desired value.
5. Return the selector switch to the “RUN” position.



## Setting the Span

### ⚠ CAUTION

Do not contact meter leads from either test terminal on the output board to case ground. Contact can result in the maximum current from the power supply flowing through the test meter and may blow the test meter fuse, or damage the test meter or transmitter.

⚠ Setting the span of the transmitter involves applying pressure and adjusting the potentiometer accordingly. To set the span of the transmitter, use the following procedure:

1. If the transmitter does not have a readout device, attach a voltmeter. Terminals for monitoring or calibrating are located in two separate locations. The first is in the terminal compartment. Connect the positive lead of the voltmeter to the “V out” terminal and the negative lead to the “-” terminal. When calibrating directly from the output board, connect the positive lead of the voltmeter to the terminal labeled “+ TEST” and the negative lead to the “- TEST” terminal, see Figure C-3.
2. Ensure that the selector switch is in the “RUN” position. Expose the transmitter to full scale pressure.
3. Set the selector switch to “S.”
4. Using the potentiometer, adjust the transmitter output until the readout device reads the desired value.
5. Return the switch to “RUN.”

### NOTE

The microprocessor limits the amount of rangedown allowed for span. If the rangedown conditions are violated, transmitter calibration is unaffected as long as the switch is placed in the “S” position and the potentiometer is adjusted.

Figure C-3. Transmitter Terminal and Electronics Compartments.

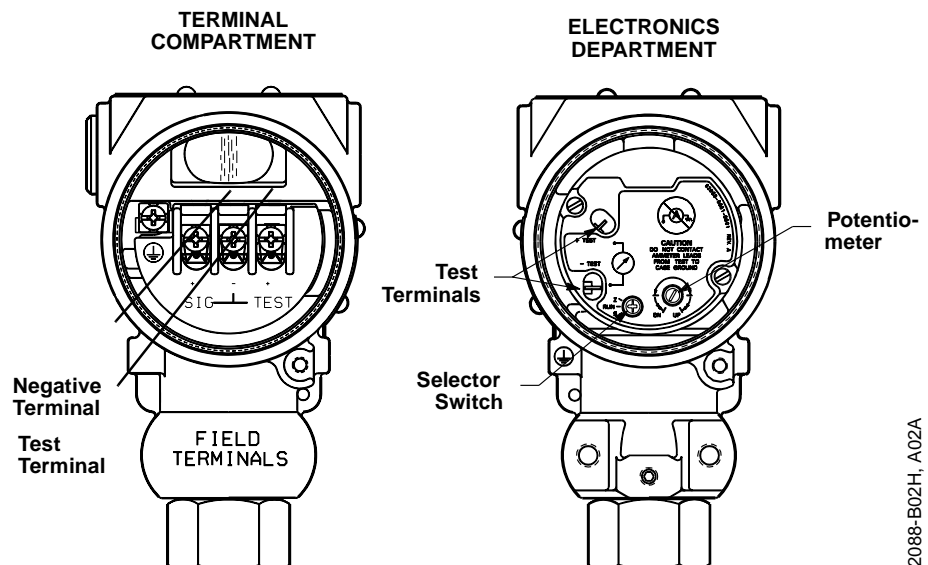

2088-B02H, A02A

## TRANSIENT PROTECTION OPTION

The transient protection option helps to protect the transmitter electronics from potentially damaging transient voltages.

The transient protection board is installed at the factory or may be installed in the field directly over the transmitter terminal block using the existing terminal screws. To install the transient protection board in the field, perform the appropriate procedure.

---

### NOTE

In order to maintain hazardous locations approvals, transient protection boards must be installed at a Rosemount Service Center. All approvals are void if customer installs transient protection boards.

---

## INSTALLATION PROCEDURES

### Transient Protection Board Installation

1. Remove the four screws on the transmitter terminal block. Save the screws and the cable clamps.
2. Disconnect the power signal wires from the terminals.
3. Insert the transient protection board directly over the terminal block, taking care to feed the power signal wires through the access cutout at the top of the board, see Figure C-4.
4. Replace and tighten the terminal screws. Take care to adequately tighten the ground (EGND) screw using the #8 lock washer provided.
5. Reconnect the signal wires, see Figure C-4.

### Transient Protection Board Wiring

The Model 2088 terminal screws remain visible with a transient protection board installed. **Do not use the existing Model 2088 terminal screws to power the transmitter; doing so will render the transient protection board useless.**

To power the low power transmitter with the transient protection board installed, connect the positive power lead to the terminal marked “+” on the transient protection board, and the negative power lead to the center terminal screw on the transmitter terminal block. Connect the positive lead from the readout device or A/D converter to the terminal marked “S” on the transient protection board, and the negative lead to the center terminal screw on the transmitter terminal block, see Figure C-4.

Figure C-4. 1–5 V dc Transient Protection Wiring.

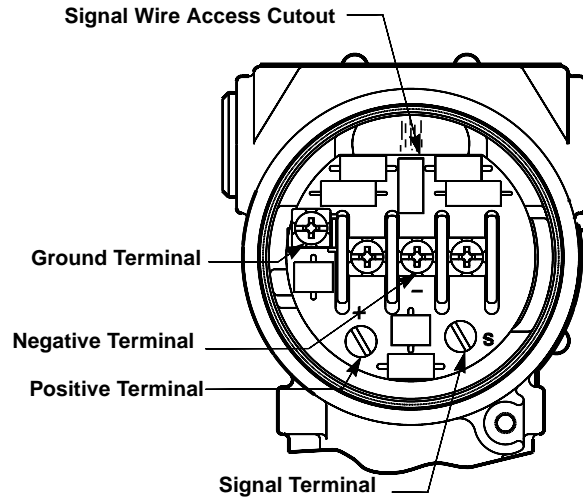

2088-1000B04B

## SPECIFICATIONS

The specifications listed below are unique to the Option code M, Low Power Analog Transmitter. All other specifications are identical to those listed in Section 5 Specifications and Reference Data.

### Functional Specifications

TABLE C-1. Ranges for Model 2088.

Range	Minimum Span	URL/Max. Span/Sensor Limit
0	1 psi (69 mbar)	8 psi (552 mbar)
1	3 psi (207 mbar)	30 psi (2,08 bar)
2	15 psi (1 bar)	150 psi (10,34 bar)
3	80 psi (5,5 bar)	800 psi (55,15 bar)
4	400 psi (27,6 bar)	4000 psi (275,79 bar)

#### Output

1–5 V dc, low power. (Outputs are directly proportional to the input pressure.)

#### Turn-on Time

0.3 seconds maximum at reference operating conditions.

#### Failure Mode

If self diagnostics detect a sensor or microprocessor failure, the analog signal is driven low to alert the user ( $I \leq 1$  V).

### Performance Specifications

#### Ambient Temperature Effect

Temperature	Ranges 1–4	Range 0
–40 to 0 °F (–40 to –18 °C)	$\pm(0.7\% \text{ URL} + 0.8\% \text{ Span})$	$\pm(1.3\% \text{ URL} + 0.5\% \text{ Span})$
0 to 140 °F (–18 to 60 °C)	$\pm(0.5\% \text{ URL} + 0.5\% \text{ Span})$	$\pm(1.0\% \text{ URL} + 0.5\% \text{ Span})$
140 to 185 °F (60 to 85 °C)	$\pm(0.7\% \text{ URL} + 0.8\% \text{ Span})$	$\pm(1.3\% \text{ URL} + 0.5\% \text{ Span})$

Total effect includes zero and span effects.





---

## **Approval Drawings**

### **OVERVIEW**

This section contains transmitter hazardous location installation drawings. Follow the installation guidelines presented by these drawings in order to maintain certified ratings for installed transmitters.

This section contains the following drawings:

Rosemount Drawing 02088-1018, Rev. AB, 7 sheets:

Index of Intrinsic Safety Factory Mutual for Models 2088 and 2090.

Rosemount Drawing 02088-1024, Rev. AA, 3 sheets:

CSA Intrinsic Safety Approvals for Models 2088 and 2090.

CONFIDENTIAL AND PROPRIETARY INFORMATION IS CONTAINED HEREIN AND MUST BE HANDLED ACCORDINGLY	REVISIONS				
	REV	DESCRIPTION	CHG. NO.	APP'D	DATE
	G	FOR T1, I <sub>max</sub> 145 was 160 mA; DEL I <sub>max</sub> for T1, GROUPS C,D	676389	P.C.S.	9/26/96
	AA	ADD SMART OUTPUT OPTION CODE "S"	RTC1002247	K.J.A.	9/25/97
	AB	CORRECT ENTITY PARAMETERS FOR SMART OUTPUT "S"	RTC1007653	J.D.J.	10/25/99

ENTITY APPROVALS

THE ROSEMOUNT 2088 / 2090 TRANSMITTER IS F.M. APPROVED AS INTRINSICALLY SAFE WHEN USED IN CIRCUIT WITH F.M. APPROVED BARRIERS WHICH MEET THE ENTITY PARAMETERS LISTED IN THE CLASS I, II, AND III, DIVISION 1 GROUPS INDICATED, ADDITIONALLY, THE ROSEMOUNT 751 FIELD SIGNAL INDICATOR IS F.M. APPROVED AS INTRINSICALLY SAFE WHEN CONNECTED IN CIRCUIT WITH ROSEMOUNT MODEL 2088 / 2090 AND F.M. APPROVED BARRIERS WHICH MEET THE ENTITY PARAMETERS LISTED FOR CLASS I, II, AND III, DIVISION 1, GROUPS INDICATED.

TO ASSURE AN INTRINSICALLY SAFE SYSTEM, THE TRANSMITTER AND BARRIER MUST BE WIRED IN ACCORDANCE WITH THE BARRIER MANUFACTURER'S FIELD WIRING INSTRUCTIONS AND THE APPLICABLE CIRCUIT DIAGRAM INDICATED ON SHEET 3.

CAD Maintained, (MICROSTATION).

UNLESS OTHERWISE SPECIFIED DIMENSIONS IN INCHES (mm). REMOVE ALL BURRS AND SHARP EDGES. MACHINE SURFACE FINISH 125  -TOLERANCE- .X ± .1 [2,5] .XX ± .02 [0,5] .XXX ± .010 [0,25]  FRACTIONS      ANGLES ± 1/32            ± 2°  DO NOT SCALE PRINT	CONTRACT NO.	<b>ROSEMOUNT MEASUREMENT</b>		Rosemount Inc. 12001 Technology Drive Eden Prairie, MN 55344 USA
	DR. <b>Myles Lee Miller</b> 10/3/90	FISHER-ROSEMOUNT		
	CHK'D	TITLE		
	APP'D <b>KAREN CARLSON</b> 10/10/90	INDEX OF I.S. F.M. FOR 2088 / 2090		
	SIZE A	FSCM NO	DWG NO. 02088-1018	
APP'D GOVT.	SCALE N/A	WT.	SHEET 1 OF 7	

2088-1018AB1

FIGURE D-1. Index of Intrinsic Safety Factory Mutual for Models 2088 and 2090 Installation Drawing 02088-1018, Rev. AB.

REVISIONS				
REV	DESCRIPTION	CHG. NO.	APP'D	DATE
AB		RTC1007653		

### 2088 / 2090 BARRIER PARAMETERS

$P_{max} = 1WATT$

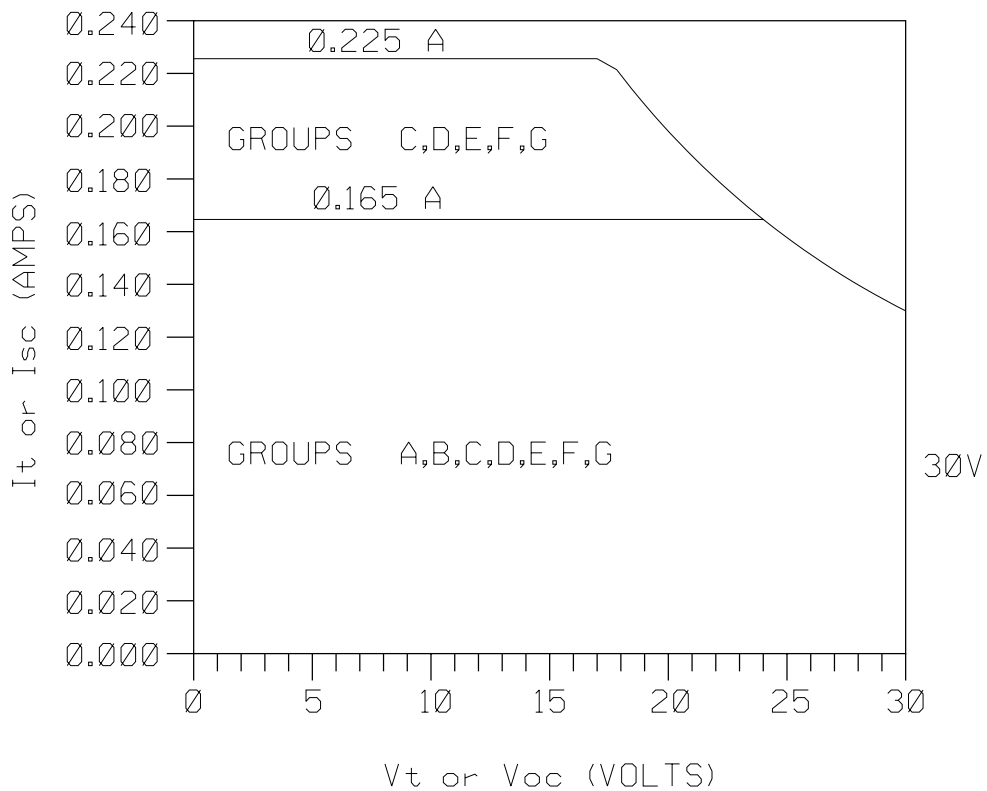

Rosemount Inc. 12001 Technology Drive Eden Prairie, MN 55344 USA		CAD Maintained, (MICROSTATION).		
DR. <b>Myles Lee Miller</b>	SIZE A	FSCM NO	DWG NO. 02088-1018	
ISSUED	SCALE N/A	WT.	SHEET 2 OF 7	

2088-1018AB2

REVISIONS				
REV	DESCRIPTION	CHG. NO.	APP'D	DATE
AB		RTC1007653		

**2088 & 2090 TRANSMITTER ("A" OUTPUT: 4-20mA)**

CIRCUIT DIAGRAM 1  
SINGLE OR DUAL CHANNEL BARRIER OR CONVERTER

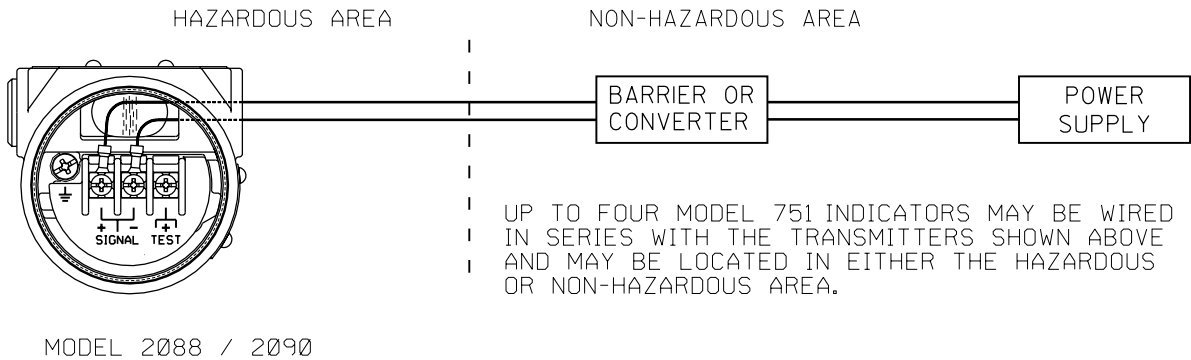

CIRCUIT DIAGRAM 2 FOR  
SUPPLY AND RETURN BARRIERS  
APPROVED IN THIS CONFIGURATION

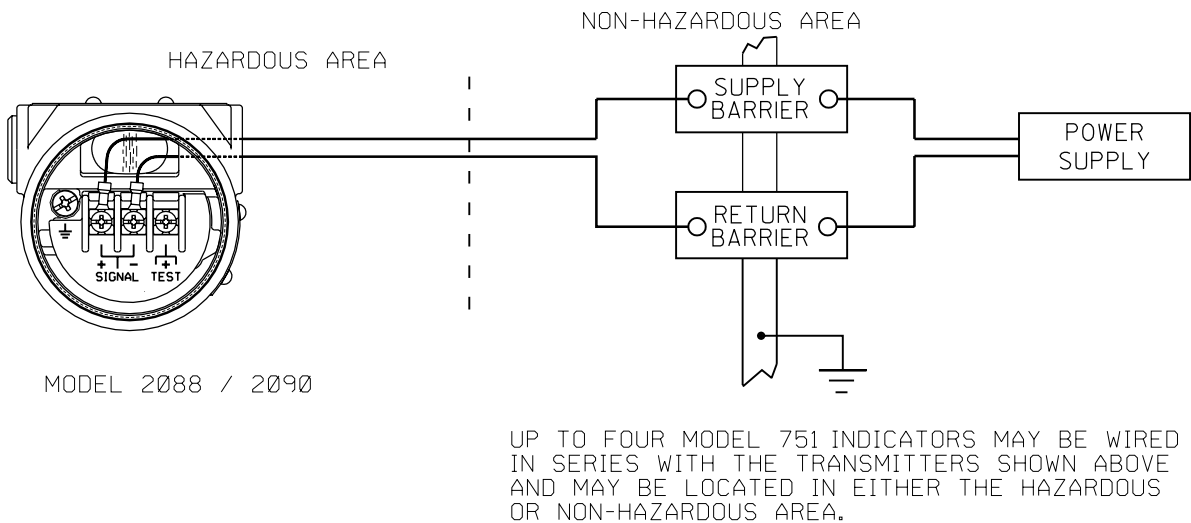

Rosemount Inc. 12001 Technology Drive Eden Prairie, MN 55344 USA		CAD Maintained, (MICROSTATION).		
DR. <b>Myles Lee Miller</b>	SIZE A	FSCM NO	DWG NO.	02088-1018
ISSUED	SCALE	N/A	WT.	SHEET 3 OF 7

2088-1018AB4

REVISIONS				
REV	DESCRIPTION	CHG. NO.	APP'D	DATE
AB		RTC1007653		

## 2088 LOW POWER TRANSMITTERS ("M" OUTPUT: 1-5V)

CIRCUIT DIAGRAM 3  
ONE DUAL CHANNEL BARRIER

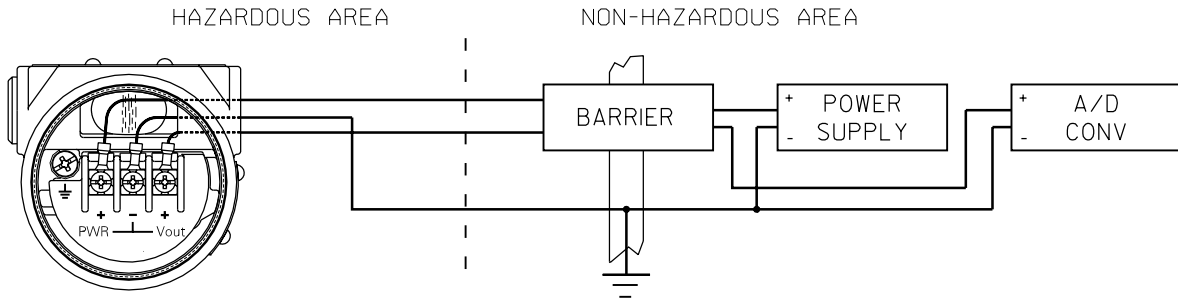

MODEL 2088

CIRCUIT DIAGRAM 2 FOR  
SUPPLY AND RETURN BARRIERS  
APPROVED IN THIS CONFIGURATION

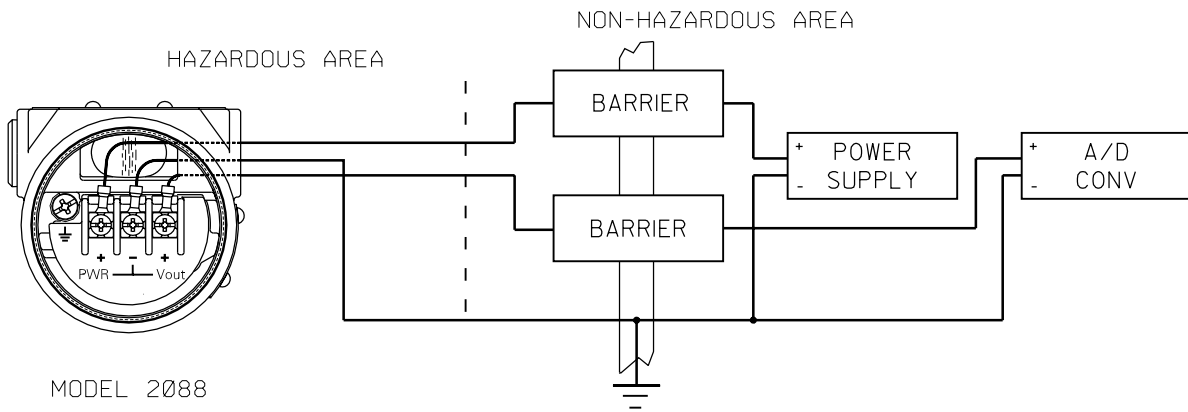

MODEL 2088

Rosemount Inc. 12001 Technology Drive Eden Prairie, MN 55344 USA		CAD Maintained, (MICROSTATION).		
DR. <b>Myles Lee Miller</b>	SIZE A	FSCM NO	DWG NO. 02088-1018	
ISSUED	SCALE N/A	WT.	SHEET 4 OF 7	

2088-1018AB5



REVISIONS				
REV	DESCRIPTION	CHG. NO.	APP'D	DATE
AB		RTC1007653		

ENTITY CONCEPT APPROVALS

THE ENTITY CONCEPT ALLOWS INTERCONNECTION OF INTRINSICALLY SAFE APPARATUS TO ASSOCIATED APPARATUS NOT SPECIFICALLY EXAMINED IN COMBINATION AS A SYSTEM. THE APPROVED VALUES OF MAXIMUM OPEN CIRCUIT VOLTAGE ( $V_{oc}$  or  $V_t$ ) AND MAXIMUM SHORT CIRCUIT CURRENT ( $I_{sc}$  or  $I_t$ ) AND MAXIMUM OUTPUT POWER ( $V_{oc} \times I_{sc}/4$ ), OR ( $V_t \times I_t/4$ ), FOR THE ASSOCIATED APPARATUS MUST BE LESS THAN OR EQUAL TO THE MAXIMUM SAFE INPUT VOLTAGE ( $V_{max}$ ), MAXIMUM SAFE INPUT CURRENT ( $I_{max}$ ), AND MAXIMUM SAFE INPUT POWER ( $P_{max}$ ) OF THE INTRINSICALLY SAFE APPARATUS. IN ADDITION, THE APPROVED MAXIMUM ALLOWABLE CONNECTED CAPACITANCE ( $C_a$ ) OF THE ASSOCIATED APPARATUS MUST BE GREATER THAN THE SUM OF THE INTERCONNECTING CABLE CAPACITANCE AND THE UNPROTECTED INTERNAL CAPACITANCE ( $C_i$ ) OF THE INTRINSICALLY SAFE APPARATUS, AND THE APPROVED MAXIMUM ALLOWABLE CONNECTED INDUCTANCE ( $L_a$ ) OF THE ASSOCIATED APPARATUS MUST BE GREATER THAN THE SUM OF THE INTERCONNECTING CABLE INDUCTANCE AND THE UNPROTECTED INTERNAL INDUCTANCE ( $L_i$ ) OF THE INTRINSICALLY SAFE APPARATUS.

NOTE: ENTITY PARAMETERS LISTED APPLY ONLY TO ASSOCIATED APPARATUS WITH LINEAR OUTPUT.

MODEL 2088 / 2090

CLASS I, DIV. 1, GROUPS A AND B

$V_{MAX} = 30V$	$V_t$ or $V_{oc}$ IS LESS THAN OR EQUAL TO 30V
$I_{MAX} = 165mA$	$I_t$ or $I_{sc}$ IS LESS THAN OR EQUAL TO 165mA
$P_{MAX} = 1 \text{ WATT}$	$(V_{oc} \times I_{sc}/4)$ or $(V_t \times I_t/4)$ IS LESS THAN OR EQUAL TO 1 WATT
$C_I = 0.012 \mu F$	$C_A$ IS GREATER THAN $0.012 \mu F$ .
$L_I = 20 \mu H$	$L_A$ IS GREATER THAN $20 \mu H$ .

FOR T1 OPTION:

$I_{MAX} = 145mA$	$I_t$ or $I_{sc}$ IS LESS THAN OR EQUAL TO 145mA
$L_I = 1.448 \text{ mH}$	$L_A$ IS GREATER THAN 1.448 mH.

CLASS I, DIV. 1, GROUPS C AND D

$V_{MAX} = 30V$	$V_t$ or $V_{oc}$ IS LESS THAN OR EQUAL TO 30V
$I_{MAX} = 225mA$	$I_t$ or $I_{sc}$ IS LESS THAN OR EQUAL TO 225mA
$P_{MAX} = 1 \text{ WATT}$	$(V_{oc} \times I_{sc}/4)$ or $(V_t \times I_t/4)$ IS LESS THAN OR EQUAL TO 1 WATT
$C_I = 0.012 \mu F$	$C_A$ IS GREATER THAN $0.012 \mu F$ .
$L_I = 20 \mu H$	$L_A$ IS GREATER THAN $20 \mu H$ .

FOR T1 OPTION:

$L_I = 1.448 \text{ mH}$	$L_A$ IS GREATER THAN 1.448 mH.
--------------------------	---------------------------------

Rosemount Inc. 12001 Technology Drive Eden Prairie, MN 55344 USA		CAD Maintained, (MICROSTATION).		
DR.	<b>Myles Lee Miller</b>	SIZE A	FSCM NO	DWG NO. 02088-1018
ISSUED		SCALE N/A	WT.	SHEET 5 OF 7



2088-1018AB6

REVISIONS				
REV	DESCRIPTION	CHG. NO.	APP'D	DATE
AB		RTC1007653		

## 2088 & 2090 TRANSMITTER ("S" OUTPUT: 4-20mA)

CIRCUIT DIAGRAM 1  
SINGLE OR DUAL CHANNEL BARRIER OR CONVERTER

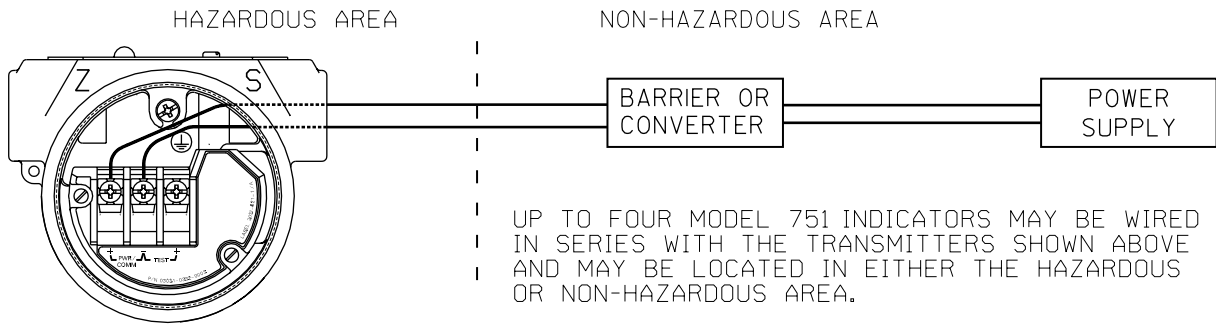

CIRCUIT DIAGRAM 2 FOR  
SUPPLY AND RETURN BARRIERS  
APPROVED IN THIS CONFIGURATION

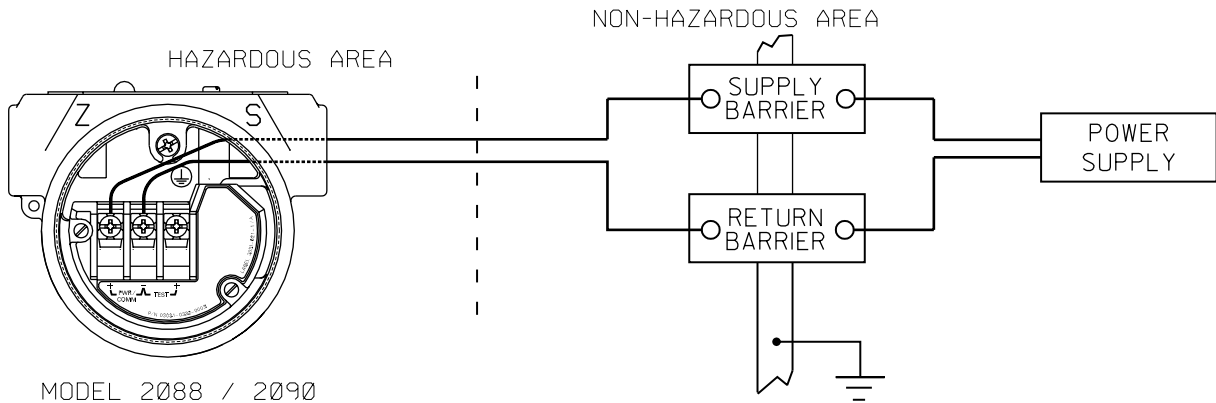

Rosemount Inc. 12001 Technology Drive Eden Prairie, MN 55344 USA	
DR.	<b>Myles Lee Miller</b>
ISSUED	

CAD Maintained, (MICROSTATION).			
SIZE	FSCM NO	DWG NO.	02088-1018
A			
SCALE	N/A	WT.	SHEET 6 OF 7

2088-1018A/B6



REVISIONS				
REV	DESCRIPTION	CHG. NO.	APP'D	DATE
AB		RTC1007653		

ENTITY CONCEPT APPROVALS

THE ENTITY CONCEPT ALLOWS INTERCONNECTION OF INTRINSICALLY SAFE APPARATUS TO ASSOCIATED APPARATUS NOT SPECIFICALLY EXAMINED IN COMBINATION AS A SYSTEM. THE APPROVED VALUES OF MAXIMUM OPEN CIRCUIT VOLTAGE ( $V_{oc}$  or  $V_t$ ) AND MAXIMUM SHORT CIRCUIT CURRENT ( $I_{sc}$  or  $I_t$ ) AND MAXIMUM OUTPUT POWER ( $V_{oc} \times I_{sc}/4$ ), OR ( $V_t \times I_t/4$ ), FOR THE ASSOCIATED APPARATUS MUST BE LESS THAN OR EQUAL TO THE MAXIMUM SAFE INPUT VOLTAGE ( $V_{max}$ ), MAXIMUM SAFE INPUT CURRENT ( $I_{max}$ ), AND MAXIMUM SAFE INPUT POWER ( $P_{max}$ ) OF THE INTRINSICALLY SAFE APPARATUS. IN ADDITION, THE APPROVED MAXIMUM ALLOWABLE CONNECTED CAPACITANCE ( $C_a$ ) OF THE ASSOCIATED APPARATUS MUST BE GREATER THAN THE SUM OF THE INTERCONNECTING CABLE CAPACITANCE AND THE UNPROTECTED INTERNAL CAPACITANCE ( $C_i$ ) OF THE INTRINSICALLY SAFE APPARATUS, AND THE APPROVED MAXIMUM ALLOWABLE CONNECTED INDUCTANCE ( $L_a$ ) OF THE ASSOCIATED APPARATUS MUST BE GREATER THAN THE SUM OF THE INTERCONNECTING CABLE INDUCTANCE AND THE UNPROTECTED INTERNAL INDUCTANCE ( $L_i$ ) OF THE INTRINSICALLY SAFE APPARATUS.

NOTE: ENTITY PARAMETERS LISTED APPLY ONLY TO ASSOCIATED APPARATUS WITH LINEAR OUTPUT.

MODEL 2088 / 2090 ("S" OUTPUT)

CLASS I, DIV. 1, GROUPS A AND B

$V_{MAX} = 30V$	$V_t$ or $V_{oc}$ IS LESS THAN OR EQUAL TO 30V
$I_{MAX} = 165mA$	$I_t$ or $I_{sc}$ IS LESS THAN OR EQUAL TO 165mA
$P_{MAX} = 1 \text{ WATT}$	$(V_{oc} \times I_{sc}/4)$ or $(V_t \times I_t/4)$ IS LESS THAN OR EQUAL TO 1 WATT
$C_I = 0.01 \mu F$	$C_A$ IS GREATER THAN $0.01 \mu F$ .
$L_I = 10 \mu H$	$L_A$ IS GREATER THAN $10 \mu H$ .

FOR T1 OPTION:

$I_{MAX} = 160mA$	$I_t$ or $I_{sc}$ IS LESS THAN OR EQUAL TO 145mA
$L_I = 1.06 \text{ mH}$	$L_A$ IS GREATER THAN 1.06 mH.

CLASS I, DIV. 1, GROUPS C AND D

$V_{MAX} = 30V$	$V_t$ or $V_{oc}$ IS LESS THAN OR EQUAL TO 30V
$I_{MAX} = 225mA$	$I_t$ or $I_{sc}$ IS LESS THAN OR EQUAL TO 225mA
$P_{MAX} = 1 \text{ WATT}$	$(V_{oc} \times I_{sc}/4)$ or $(V_t \times I_t/4)$ IS LESS THAN OR EQUAL TO 1 WATT
$C_I = 0.01 \mu F$	$C_A$ IS GREATER THAN $0.01 \mu F$ .
$L_I = 10 \mu H$	$L_A$ IS GREATER THAN $10 \mu H$ .

FOR T1 OPTION:

$L_I = 1.06 \text{ mH}$	$L_A$ IS GREATER THAN 1.06 mH.
-------------------------	--------------------------------

Rosemount Inc. 12001 Technology Drive Eden Prairie, MN 55344 USA		CAD Maintained, (MICROSTATION).		
DR. <b>Myles Lee Miller</b>	SIZE A	FSCM NO	DWG NO. 02088-1018	
ISSUED	SCALE N/A	WT.	SHEET 7 OF 7	



2088-1018AB7



AA	ADD SMART OUTPUT OPTION "S"	RTC1002227	M.L.M.	10/9/97
----	-----------------------------	------------	--------	---------

CSA INTRINSIC SAFETY APPROVALS  
CIRCUIT CONNECTION WITH BARRIER OR CONVERTER

Ex ia  
INTRINSICALLY SAFE/SECURITE INTRINSEQUE

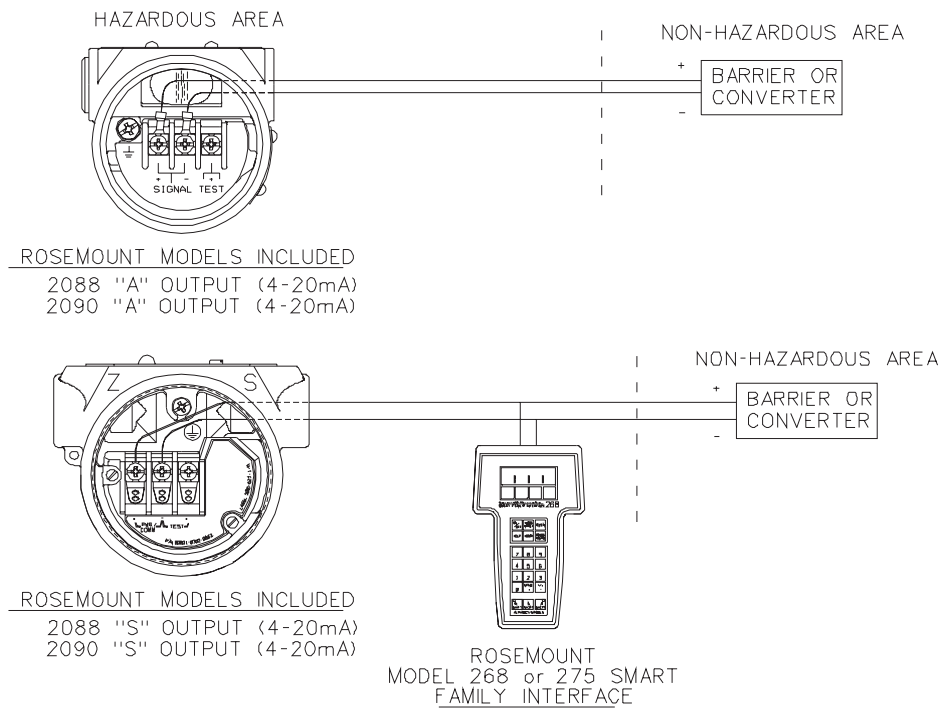

SANDI MANSON 12/12/90

KAREN CARLSON 12/20/90

INDEX OF I.S. CSA FOR  
2088 / 2090

02088-1024

N/A ————— 1 3

2088-1024\_01A

FIGURE D-2. CSA Intrinsic Safety Approvals for Models 2088 and 2090, Rev. AA.

AA | \_\_\_\_\_ | RTC1002227 | \_\_\_\_\_

WARNING - EXPLOSION HAZARD - SUBSTITUTION OF COMPONENTS  
MAY IMPAIR SUITABILITY FOR CLASS I, DIVISION 2.

AVERTISSEMENT - RISQUE D'EXPLOSION - LA SUBSTITUTION DE COMPOSANTS  
PEUT RENDRE CE MATERIEL INACCEPTABLE POUR LES EMBLEMES  
DE CLASSE I, DIVISION 2.

DEVICE	PARAMETERS	APPROVED FOR CLASS I, DIV.1
CSA APPROVED SAFETY BARRIER	30 V OR LESS	GROUPS A, B, C, D
	330 OHMS OR MORE	
	28 V OR LESS	
	300 OHMS OR MORE	
	25 V OR LESS	
FOXBORO CONVERTER 2A1-12V-CGB, 2A1-13V-CGB, 2AS-131-CGB, 3A2-12D-CGB, 3A2-13D-CGB, 3AD-131-CGB, 3A4-12D-CGB, 2AS-121-CGB, 3F4-12DA	200 OHMS OR MORE	GROUPS B, C, D
	22 V OR LESS	
	180 OHMS OR MORE	
CSA APPROVED SAFETY BARRIER	30 V OR LESS 150 OHMS OR MORE	GROUPS C, D

SANDI MANSON

N/A

02088-1024

2 3

AA | RTC1002227 |

CSA INTRINSIC SAFETY APPROVALS  
 2088 LOW POWER CIRCUIT CONNECTION WITH INTRINSIC SAFETY BARRIERS  
 Ex ia  
 INTRINSICALLY SAFE/SECURITE INTRINSEQUE

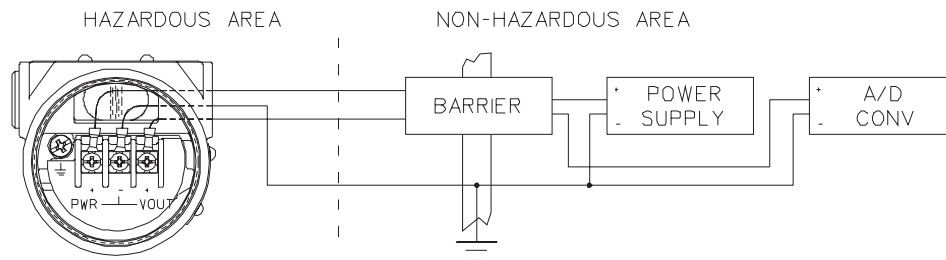
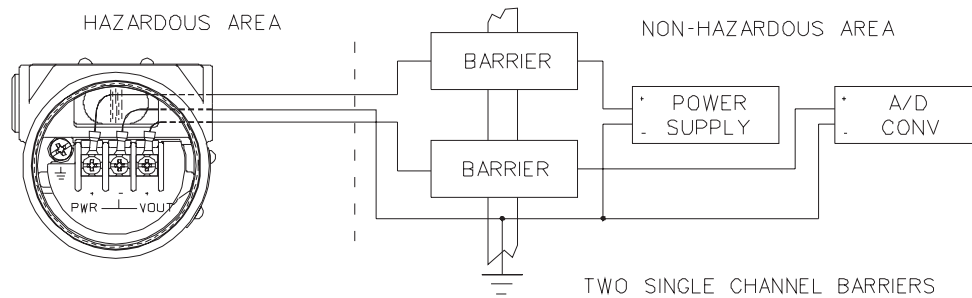

2088 LOW POWER  
 2088 "M" OUTPUT (1-5 V)

APPROVED FOR CLASS 1, DIVISION 1, GROUPS A,B,C,D WHEN USED IN CIRCUIT WITH TWO CSA APPROVED SINGLE CHANNEL SAFETY BARRIERS, ONE WITH APPROVED SAFETY PARAMETERS OF 28 VOLTS OR LESS AND 300 OHMS OR MORE IN +PWR LINE, AND ONE WITH APPROVED SAFETY PARAMETERS OF 10 VOLTS OR LESS AND 47 OHMS OR MORE IN Vout LINE, OR ONE CSA APPROVED DUAL CHANNEL SAFETY BARRIER WITH IDENTICAL APPROVED SAFETY PARAMETERS CONNECTED IN LIKE MANNER, AS ABOVE.

APPROVED FOR CLASS 1, DIVISION 1, GROUPS C,D WHEN USED IN CIRCUIT WITH TWO CSA APPROVED SINGLE CHANNEL SAFETY BARRIERS, ONE WITH APPROVED SAFETY PARAMETERS OF 30 VOLTS OR LESS AND 150 OHMS OR MORE IN +PWR LINE AND ONE WITH APPROVED SAFETY PARAMETERS OF 10 VOLTS OR LESS AND 47 OHMS OR MORE IN Vout LINE.

Myles Lee Miller

02088-1024

N/A ——— 3 3

2088-1024\_03A



## European ATEX Directive Information

Rosemount Model 2088, 2090P, and 2090F Smart Pressure Transmitters that have the following label attached, have been certified to comply with Directive 94/9/EC of the European Parliament and the Council as published in the Official Journal of the European Communities No. L 100/1 on 19 April 1994.

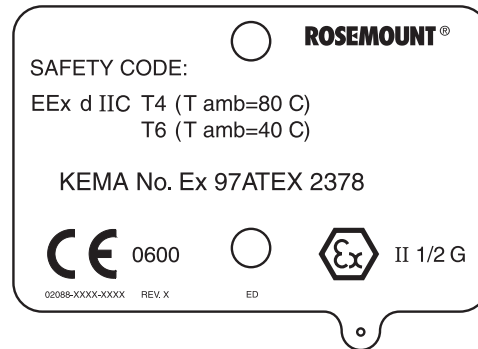

275\_01A

The following information is provided as part of the labeling of the transmitter

- Name and address of the manufacturer (may be any of the following):
  - Rosemount USA
  - Rosemount England
  - Rosemount Germany
  - Rosemount Singapore



- Complete model number
- The serial number of the device
- Year of construction
- Marking for explosion protection:
  - EEx d IIC T6 (Ta = 40 °C)
  - EEx d IIC T4 (Ta = 80 °C)



- KEMA ATEX certificate number: 97ATEX 2378



---

# Index

- A**  
Access requirements 3-6  
Action keys B-5  
Address 2-11  
Approval Drawings D-1–D-5
- B**  
Basic setup  
    Damping 2-4  
    Output units 2-3  
    Rerange 2-3  
    Tag 2-3  
Burst mode 2-5
- C**  
Calibration 2-6  
    Full trim 2-8  
    Output trim 2-8  
    Overview 2-6  
    Sensor trim 2-7  
    Zero trim 2-7  
Commissioning the Smart transmitter 2-2  
Communicating with a multidrop 2-11  
Configuration data  
    Clone 2-6  
    Recall 2-6  
    Save 2-6  
Connecting to a transmitter loop 2-2  
Custom meter configuration A-2
- D**  
Damping 2-4  
Detailed setup  
    Burst mode 2-5  
    Clone configuration data 2-6  
    Meter setup 2-5  
    Save, recall, clone configuration data 2-6  
Diagnostics and service 2-10  
Dimensional drawings  
    Model 2088 3-6  
    Model 2090F 3-6  
    Model 2090P 3-6  
    Mounting bracket 3-6  
Disassembly procedure 4-5  
Downscale alarm 4-4  
Drawings  
    Approval D-1
- E**  
Electrical considerations 3-11  
    Load limitations 3-11  
    Power supply 3-11  
Environmental considerations 3-3  
European ATEX directive information E-1
- F**  
Failure mode alarm 3-12  
Field wiring 3-11  
    Low power C-2  
Full trim 2-8  
Functional specifications 5-1
- H**  
HART communicator B-1  
    Action keys B-5, B-6  
    Data entry B-6  
    Function keys B-6  
    Model 275 B-1  
Hazardous locations 3-3
- I**  
Impulse piping 3-5  
Installation  
    Electrical considerations 3-11  
    Environmental considerations 3-3  
    General considerations 3-3  
    Hazardous locations 3-3  
    Mechanical considerations 3-4  
Introduction 1-1
- K**  
Keypad  
    Action keys B-5, B-6  
    Function keys B-6
- L**  
LCD meter  
    Custom meter configuration A-2  
    Diagnostic messages A-3  
Load limitations 3-11  
Low power option  
    Calibration C-3  
    Commissioning C-1  
    Installation C-1
- Potentiometer  
    adjustment C-4  
Setting span C-5  
Setting zero C-4  
Specifications C-7  
Transient protection C-6  
Wiring C-2
- M**  
Maintenance 4-1  
    Disassembly procedure 4-5  
    Reassembly procedure 4-5  
    Returning product 4-6  
Mechanical considerations 3-4  
Meter setup 2-5  
Model 2090F 3-10  
Model 2090P 3-7  
Model 275 HART communicator B-1  
Mounting  
    Model 2088 3-4  
    Model 2090F 3-4  
    Model 2090P 3-4  
Mounting configurations 3-4  
    Using a sanitary fitting 3-10  
    Using a weld spud 3-9  
Multidrop communication 2-10
- N**  
NAMUR-compliant operation 3-12
- O**  
Ordering information 5-10  
    Model 2088 5-10  
    Model 2090F 5-12  
    Model 2090P 5-11  
Output trim 2-8  
Output units 2-3
- P**  
Performance specifications 5-3  
Physical specifications 5-5  
Polling a multidrop loop 2-11  
Potentiometer adjustment C-4  
Power supply 3-11

**R**

Range values 2-4  
Reassembly procedure 4-5  
Reference data 5-1  
Replacement parts  
    Model 2088 5-7  
    Model 2090F 5-9  
    Model 2090P 5-8  
Rerange 2-3  
Returning product 4-6

**S**

Safety messages 1-1  
Security (Write protection) 3-13  
Security jumpers 3-12  
Sensor Trim 2-7  
Sensor trim  
    Full trim 2-8  
    Zero trim 2-7  
Set sensor type 2-3  
Spare parts 5-7  
Specifications 5-1  
    Functional 5-1  
    Performance 5-3  
    Physical 5-5

**T**

Tag 2-3  
Transient protection C-6  
Troubleshooting 4-1

**W**

Weld spud 3-8  
Wiring 3-11  
    Low power C-2

**Z**

Zero and span adjustments 3-14  
Zero trim 2-7





**Rosemount Inc.**

8200 Market Boulevard  
Chanhassen, MN 55317 USA  
Tel 1-800-999-9307  
Fax (612) 949-7001  
© 2000 Rosemount Inc.



<http://www.rosemount.com>



00809-0100-4690 Rev. DA 01/00

**Fisher-Rosemount Limited**

Heath Place  
Bognor Regis  
West Sussex PO22 9SH  
England  
Tel 44 (1243) 863 121  
Fax 44 (1243) 867 5541

**Fisher-Rosemount  
Singapore Pte Ltd.**

1 Pandan Crescent  
Singapore 128461  
Tel (65) 777-8211  
Fax (65) 770-8007

**ROSEMOUNT®**

**FISHER-ROSEMOUNT™ Managing The Process Better.™**