



CCGPS Math Grade 8 Unit 1
Transformations, Congruence, and Similarity
 08-05-13 to 09-06-13
(5 WEEKS)

Contents	
Unit Overview	2
Connections to Previous Learning.....	2
Connections to Future Learning.....	2
Content Standards	2
Focus Standards for Mathematical Practice	3
SMP 2: Reason abstractly and quantitatively.....	3
SMP 3: Construct viable arguments and critique the reasoning of others.	3
SMP 4: Model with mathematics.	3
Learning Targets.....	3
Concept Overview	4
Suggested Timeline	4
Grade 8 Unit 1 Prerequisite Skills	5
A. Congruence of Rigid Transformations	5
Learning Targets.....	5
Concept Overview	5
Vocabulary.....	6
Sample Problems	6
Resources, Teacher Notes, and Instructional Strategies.....	7
B. Similarity of Transformations	12
Learning Targets.....	13
Concept Overview	13
Vocabulary.....	13
Sample Problems	14
Resources, Teacher Notes, and Instructional Strategies.....	14
C. Proportional Parts of Parallel Lines with a Transversal	16
Learning Targets.....	16
Concept Overview	16
Vocabulary.....	17
Sample Problems	17
Resources, Teacher Notes, and Instructional Strategies.....	19
Grade 8 Unit 1 Summative Assessment	20

Unit Overview

What is this unit about?

Congruence of rigid Transformations such as translation, rotation, reflection that preserve length, perimeter, area, and angles measurement. Similarity of Transformations caused by dilation.

Focus on geometric shape (their components, and their categorization based on those properties), composing and decomposing geometric shapes, spatial relations and spatial structuring

A major focus in Grade 8 is to use knowledge of angles and distance to analyze two- and three-dimensional figures and space in order to solve problems. This cluster interweaves the relationships of symmetry, transformations, and angle relationships to form understandings of similarity and congruence. Inductive and deductive reasoning are utilized as students forge into the world of proofs. Informal arguments are justifications based on known facts and logical reasoning. Students should be able to appropriately label figures, angles, lines, line segments, congruent parts, and images (primes or double primes). Students are expected to use logical thinking, expressed in words using correct terminology. They are NOT expected to use theorems, axioms, postulates or a formal format of proof as in two-column proofs.

Why is this unit important?

It begins the thinking of functional understanding. Look at Connections to Future Learning. Students should solve mathematical and real-life problems involving understandings from this cluster. Investigation, discussion, justification of their thinking, and application of their learning will assist in the more formal learning of geometry in high school.

Connections to Previous Learning

How does this content connect to previous learning?

In 6th grade, draw polygons in the coordinate plane given coordinates for the vertices; use coordinates to find the length of a side joining points with the same first coordinate or the same second coordinate. In 7th grade, students draw, construct and describe geometrical figures and describe the relationships between them. Students develop an understanding of the special relationships of angles and their measures (complementary, supplementary, adjacent, vertical). Now, the focus is on learning the about the sum of the angles of a triangle and using it to, find the measures of angles formed by transversals (especially with parallel lines), or to find the measures of exterior angles of triangles and to informally prove congruence.

Connections to Future Learning

How does this content prepare students for future learning?

In the eighth grade, students are to focus on functional relationships, recognizing various linear relationships and identifying functional relationships which are not linear. This is the 1st unit because students can begin to form functional relationships with transformations in the coordinate plane. E.g. Pre-image $(x, y) \rightarrow$ rule $(x+2, y+ 4) \rightarrow$ image (x', y') . Here you can see the input, rule, output relationship. This is one way students can be introduced into functions. Later, you will discuss functions in full in Unit 4.

Content Standards

Understand congruence and similarity using physical models, transparencies, or geometry software.

MCC8.G.1 Verify experimentally the properties of rotations, reflections, and translations:

- a. Lines are taken to lines, and line segments to line segments of the same length.
- b. Angles are taken to angles of the same measure.
- c. Parallel lines are taken to parallel lines.

MCC8.G.2 Understand that a two-dimensional figure is congruent to another if the second can be obtained from the first by a sequence of rotations, reflections, and translations; given two congruent figures, describe a sequence that exhibits the congruence between them.

MCC8.G.3 Describe the effect of dilations, translations, rotations, and reflections on two-dimensional figures using coordinates.

MCC8.G.4 Understand that a two-dimensional figure is similar to another if the second can be obtained from the first by a sequence of rotations, reflections, translations, and dilations; given two similar two-dimensional figures, describe a sequence that exhibits the similarity between them.

MCC8.G.5 Use informal arguments to establish facts about the angle sum and exterior angle of triangles, about the angles created when parallel lines are cut by a transversal, and the angle-angle criterion for similarity of triangles. *For example, arrange three copies of the same triangle so that the three angles appear to form a line, and give an argument in terms of transversals why this is so.*

Focus Standards for Mathematical Practice

SMP 2: Reason abstractly and quantitatively.

In grade 8, students represent a wide variety of real world contexts through the use of real numbers and variables in mathematical expressions, equations, and inequalities. They examine patterns in data and assess the degree of linearity of functions. Students contextualize to understand the meaning of the number or variable as related to the problem and decontextualize to manipulate symbolic representations by applying properties of operations.

Essential Questions

How can I use concrete and abstract reasoning to help prove that an interior angle and corresponding exterior angle of a triangle are supplementary?

SMP 3: Construct viable arguments and critique the reasoning of others.

In grade 8, students construct arguments using verbal or written explanations accompanied by expressions, equations, inequalities, models, and graphs, tables, and other data displays (i.e. box plots, dot plots, histograms, etc.). They further refine their mathematical communication skills through mathematical discussions in which they critically evaluate their own thinking and the thinking of other students. They pose questions like “How did you get that?”, “Why is that true?” “Does that always work?” They explain their thinking to others and respond to others’ thinking.

Essential Questions

Why is it that once a figure is translated, rotated, or reflected across a line, the figure and its image are congruent?

SMP 4: Model with mathematics.

In grade 8, students model problem situations symbolically, graphically, tabularly, and contextually. Students form expressions, equations, or inequalities from real world contexts and connect symbolic and graphical representations. Students solve systems of linear equations and compare properties of functions provided in different forms. Students use scatter plots to represent data and describe associations between variables. Students need many opportunities to connect and explain the connections between the different representations. They should be able to use all of these representations as appropriate to a problem context.

Essential Questions

How does a figure change after a dilation less than 1? Use graph paper to model.

Learning Targets

I can ...

- Verify for a figure that has been translated, reflected, and/or rotated has same length, perimeter, area, angle measures, and correspondence. (SMP 3)
- Perform a series of transformations (reflections, rotations, and/or translations) to prove or disprove that two given figures are congruent. (SMP 4)
- Describe the changes occurring to the x- and y- coordinates of a figure after a rotation, translations, reflection and/or

dilation. (SMP 2)

Concept Overview

<http://www.insidemathematics.org/index.php/standard-2> SMP 2 Inside Mathematics Website

<http://www.insidemathematics.org/index.php/standard-3> SMP 3 Inside Mathematics Website

<http://www.insidemathematics.org/index.php/standard-4> SMP 4 Inside Mathematics Website

The Common Core, Clarifying Expectations for Teachers & Students, Math Grade 8 by McGraw Hill

Suggested Timeline

Understand congruence and similarity using physical models, transparencies, or geometry software.

Time	Topic
MCC8.G.1 Verify experimentally the properties of rotations, reflections, and translations:	
1 day	Explore and discover rotation
1 day	Explore and discover reflection
1 day	Explore and discover translation
MCC8.G.2 Understand that a two-dimensional figure is congruent to another if the second can be obtained from the first by a sequence of rotations, reflections, and translations; given two congruent figures, describe a sequence that exhibits the congruence between them.	
2 days	Verify congruency of the 3 rigid transformations Practice the 3 rigid transformations individually and with sequence or more than 1
MCC8.G.3 Describe the effect of dilations, translations, rotations, and reflections on two-dimensional figures using coordinates.	
4 days	Practice of sequenced rigid transformations in the coordinate plane using coordinate notation Emphasis pre-image, rule, image
MCC8.G.4 Understand that a two-dimensional figure is similar to another if the second can be obtained from the first by a sequence of rotations, reflections, translations, and dilations; given two similar two-dimensional figures, describe a sequence that exhibits the similarity between them.	
4 days	Similarity of figures through transformations. Explore and discover dilation
MCC8.G.5 Use informal arguments to establish facts about the angle sum and exterior angle of triangles, about the angles created when parallel lines are cut by a transversal, and the angle-angle criterion for similarity of triangles. <i>For example, arrange three copies of the same triangle so that the three angles appear to form a line, and give an argument in terms of transversals why this is so.</i>	
1 day	Angles of lines and triangles
2 days	Parallel line properties, theorems, postulates with transversal
1 day	Angle -Angle Similarity of triangle
1 day	Triangle Proportionality
Culminating Review and Assessment	
5 days	Culminating Review and Assessment

Grade 8 Unit 1 Prerequisite Skills

Teachers can then use the Computer Adaptive Data to determine which students have not mastered these standards to provide remediation before the unit begins.

- MCC7.G.1 Knowledge of the coordinate plane
- MCC6.G.1 Find perimeter and area
- MCC6.RP.3 Proportions

Formative Pre-assessment Tasks



MA_G8_U1 PreTest
Task - CongruentRect



MA_G8_U1 PreTest
Task - FindTheMissing

A. Congruence of Rigid Transformations

Understand congruence and similarity using physical models, transparencies, or geometry software.

MCC8.G.1 Verify experimentally the properties of rotations, reflections, and translations:

- a. Lines are taken to lines, and line segments to line segments of the same length.
- b. Angles are taken to angles of the same measure.
- c. Parallel lines are taken to parallel lines.

MCC8.G.2 Understand that a two-dimensional figure is congruent to another if the second can be obtained from the first by a sequence of rotations, reflections, and translations; given two congruent figures, describe a sequence that exhibits the congruence between them.

MCC8.G.3 Describe the effect of *dilations, translations, rotations, and reflections* on two-dimensional figures using coordinates.

Essential Questions

- How does geometry better describe objects?
- How can the coordinate plane help me understand properties of reflections, translations, and rotations?
- What information is necessary before I can conclude two figures are congruent?

Learning Targets

I can ...

- Verify for a figure that has been translated, reflected, and/or rotated has same length, perimeter, area, angle measures, and correspondence. (G1)
- Explain how transformations can be used to prove that two figures are congruent. (G2)
- Perform a series of transformations (reflections, rotations, and/or translations) to prove or disprove that two given figures are congruent. (G2)
- Describe the changes occurring to the x- and y- coordinates of a figure after a rotation, translations, reflection and/or dilation. (G3)

Concept Overview

Students should be given time to discover and explore each of the 3 rigid transformations rotation, reflection, and translation. Students should use the rigid transformations on figures and be able to identify transformations on figures. Students should find length, perimeter, area, and angle measurement to make conjectures about congruency among the 3 rigid transformations. Follow coordinate notation rules to create transformed figures and use coordinate notation to describe

transformations. E.g. Pre-image $(x, y) \rightarrow$ rule $(x+2, y+4) \rightarrow$ image (x', y') . Here you can see the input, rule, output relationship.

Transformational geometry is about the effects of rigid motions, rotations, reflections and translations on figures. Initial work should be presented in such a way that students understand the concept of each type of transformation and the effects that each transformation has on an object before working within the coordinate system. For example, when reflecting over a line, each vertex is the same distance from the line as its corresponding vertex. This is easier to visualize when not using regular figures. Time should be allowed for students to cut out and trace the figures for each step in a series of transformations. Discussion should include the description of the relationship between the original figure and its image(s) in regards to their corresponding parts (length of sides and measure of angles) and the description of the movement, including the attributes of transformations (line of symmetry, distance to be moved, center of rotation, angle of rotation and the amount of dilation). The case of distance – preserving transformation leads to the idea of congruence.

It is these distance-preserving transformations that lead to the idea of congruence.

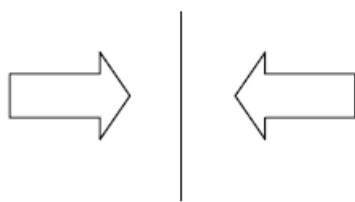

Vocabulary

rigid transformation: is one in which the pre-image and the image both have the exact same size and shape (congruent).

Transformation: The mapping, or movement, of all the points of a figure in a plane according to a common operation.

Reflection: A transformation that "flips" a figure over a line of reflection.

Rotation: A transformation that turns a figure about a fixed point through a given angle and a given direction.

Translation: A transformation that "slides" each point of a figure the same distance in the same direction.

Sample Problems

Sample Problem



SAMPLE
PROBLEM1.docx

Solution:



SAMPLE
PROBLEM1_ANSWER!

Resources, Teacher Notes, and Instructional Strategies

Standard & Topic	Resources	Teacher Notes
<p>MCC8.G.1</p> <p>Explore and Discover the 3 rigid transformations</p>	<p>Teaching Channel Transformations video: https://www.teachingchannel.org/videos/teaching-transformations?fd=1</p> <p>This site gives TI documents on exploring the 3 rigid transformations; provided student directions and teacher key. Resource type: Knowledge (K) http://education.ti.com/calculators/timathnspired/US/Activities/?sa=5024&t=5055</p> <p>Students can take online practice quiz for the 3 rigid transformations. Resource type: skill (S) http://www.quia.com/quiz/1651464.html</p> <p>State Learning Task(s)</p> <p>Task Title: Introduction to Reflections, Translations, Rotations</p> <div style="text-align: center;">  IntrotoReflectionsTranslationsRotations.doc </div>	<p>Real World Connections</p> <p>Provide real-world examples of rigid motions (e.g. Ferris wheels for rotation; mirrors for reflection; moving vehicles for translation).</p> <p>Instructional suggestions (strategies)</p> <p>Use graph paper, transparencies, tracing paper or dynamic geometry software to obtain images of a given figure under specified transformations.</p> <p>Analyze various figures (e.g. regular polygons, folk art designs or product logos) to determine which rotations and reflections carry (map) the figure onto itself. These transformations are the “symmetries” of the figure.</p> <p>Provide students with a pre-image and a final, transformed image, and ask them to describe the steps required to generate the final image. Show examples with more than one answer (e.g., a reflection might result in the same image as a translation).</p> <p>Work backwards to determine a sequence of transformations that will carry (map) one figure onto another of the same size and shape.</p> <p>Focus attention on the attributes (e.g. distances or angle measures) of a geometric figure that remain constant under various transformations.</p> <p>Student Misconceptions</p> <p>Students may think...</p> <ul style="list-style-type: none"> • The terms “mapping” and “under” are used in special ways when studying transformations. A translation is a type of transformation that moves all the points in the object in a straight line in the same direction. Students should know that not every transformation is a translation. • Students sometimes confuse the terms “transformation” and “translation” • Students sometimes believe that a reflection over $y = x$ or $y = -x$ is like a rotation of it. The correct reflection will actually look wrong compared to the original drawing. One way to help with this is to have the students physically fold their paper to make sure it does reflect over the correct line

- Students may confuse specific math vocabulary (reflection, rotation, translation) with the more casual math vocabulary for these terms (flip, turn, slide) that they learned in elementary grades.
- Students may identify the incorrect line of symmetry (x -axis vs. y -axis) when reflecting.
- When labeling transformed images, students sometimes mistakenly apply the wrong label. Either they use the wrong letter, forget the prime notation (e.g., $A \rightarrow A$ instead of $A \rightarrow A'$), or do the wrong number of primes if there is more than one transformation on the graph (ex. $A \rightarrow A''$ instead of $A \rightarrow A''$).
- In translations, students can sometimes count to their points incorrectly or switch the order of the coordinates when writing the point down.

Probing questions

- What happens to the coordinates when you reflect or rotate a point in the coordinate plane?
- What are the similarities and differences between the images and pre-images generated by translations?

Differentiation Strategies

Provide both individual and small-group activities, allowing adequate time for students to explore and verify conjectures about transformations and develop precise definitions of rotations, reflections and translations.

Use cut-outs, promethean characteristics, and geoboards to represent rigid motions, including physical manipulatives, coordinate methods, and dynamic geometry software. Like Geometer's Sketchpad and Geogebra

Cooperative Learning Strategies

WORKSTATION JIGSAW

Each student in a group will go to a different workstation to learn about the different transformations. They will return to their teammates to report on what they learned. One station will be about translations. One station will be about rotations. One station will be about reflections. The students will need to do a takeaway activity to familiarize them with each transformation. They will then go back to their

		<p>group to explain to their group members the transformation they learned.</p> <p>Literacy Strategies</p> <p>Vocabulary Tree- The Vocabulary Tree is a graphic organizational strategy that is very useful in mathematics and note-taking. It is one of my favorite strategies for building vocabulary, and through the use of the Vocabulary Tree, students make connections and identify relationships between vocabulary words in the lesson. The Vocabulary Tree is made up of a trunk, roots, branches, and leaves. The trunk holds the main concept or key term, and the branches include related terms, ideas, or examples. The leaves of the tree are used for the definitions of the terms or ideas listed in the branches. Finally, the roots of the tree are reserved for the definition or Latin root of the key term.</p> <p>Choose three words to create the vocabulary tree. A separate tree is needed for each word.</p>  <p>vocabularytreeexample_literacystrategy.j</p>
<p>MCC8.G.2 Congruency of rigid transformations</p>	<p>Utilize geometric descriptions to change figures and to anticipate the effect of a given transformation; utilize congruence to find whether two figures are congruent.</p> <p>http://learni.st/users/S33572/boards/2773-defining-congruence-in-terms-of-rigid-motions-common-core-standard-9-12-g-co-6</p> <p>Rigid Transformations Exploration Lesson</p>  <p>Congruency.pdf</p> <p>State Learning Task(s)</p> <p>Task Title Coordinating Reflections, Translations, and Rotations</p>  <p>SLT_CoordinatingReflectionsTranslationsR</p>	<p>Model Lesson</p>  <p>representing_combining_transformations_l</p>  <p>representing_and_combining_transformation</p> <p>Instructional suggestions (strategies)</p> <p>Develop the relationship between transformations and congruency. Allow adequate time and provide hands-on activities for students to visually and physically explore rigid motions and congruence.</p> <p>Use graph paper, tracing paper or dynamic geometry software to obtain images of a given figure under specified rigid motions. Note that size and shape are preserved.</p> <p>Use rigid motions (translations, reflections and rotations) to determine if two figures are congruent. Compare a given triangle and its image to verify that corresponding sides and corresponding angles are congruent.</p>

Work backwards – given two figures that have the same size and shape, find a sequence of rigid motions that will map one onto the other.

Student Misconceptions

Students may think...

- That all transformations, including dilation, are rigid motions. Provide counterexamples of this misconception.
- That any two figures that have the same area represent a rigid transformation. Students should recognize that the areas remain the same, but preservation of side and angle lengths determine that the transformation is rigid.
- That corresponding vertices do not have to be listed in order; however, it is useful to stress the importance of listing corresponding vertices in the same order so that corresponding sides and angles can be easily identified and that included sides or angles are apparent.

Probing questions

- What is the relationship between reflections, translations and rotations?
- What is the relationship between a side of a polygon and its translated image?

Differentiation Strategies

Provide both individual and small-group activities, allowing adequate time for students to explore and verify conjectures about transformations and develop precise definitions of rotations, reflections and translations.

Use cut-outs, promethean characteristics, and geoboards to represent rigid motions, including physical manipulatives, coordinate methods, and dynamic geometry software.



Cooperative Learning Strategies

THINK-PAIR-SHARE

- Students will work with a partner to determine if translating a figure will change its location, size, both, or neither. Explain how you know. Partners will then share with the class randomly.

Literacy Strategies

Vocabulary Tree- The Vocabulary Tree is a graphic organizational strategy that is very useful in

		<p>mathematics and note-taking. It is one of my favorite strategies for building vocabulary, and through the use of the Vocabulary Tree, students make connections and identify relationships between vocabulary words in the lesson. The Vocabulary Tree is made up of a trunk, roots, branches, and leaves. The trunk holds the main concept or key term, and the branches include related terms, ideas, or examples. The leaves of the tree are used for the definitions of the terms or ideas listed in the branches. Finally, the roots of the tree are reserved for the definition or Latin root of the key term.</p> <p>Choose the remaining words to create the vocabulary tree. A separate tree is needed for each word</p>  <p>vocabularytreeexample_literacystrategy.j</p>
<p>MCC8.G.3 Transformations in the Coordinate Plane</p>	<p>Geometry software to help students explore geometry. Resource type: understanding (U). http://geogebra.org/cms/</p> <p>Reflections on the Coordinate Plane (S,U) http://enlvm.usu.edu/ma/nav/activity.jsp?sid=shared&cid=wyomi3@emready_transformations&lid=9</p> <p>Translations on the Coordinate Plane (S,U) http://enlvm.usu.edu/ma/nav/activity.jsp?sid=shared&cid=wyomi3@emready_transformations&lid=15</p>	<p>Instructional suggestions (strategies)</p> <p>Make the transition from transformations as physical motions to functions that take points in the plane as inputs and give other points as outputs. The correspondence between the initial and final points determines the transformation.</p> <p>Emphasize the importance of understanding a transformation as the correspondence between initial and final points, rather than the physical motion.</p> <p>Model Lesson</p>  <p>Model Lesson Plan 2.docx</p> <p>Student Misconceptions</p> <p>Students may think...</p> <ul style="list-style-type: none"> • The terms “mapping” and “under” are used in special ways when studying transformations. A translation is a type of transformation that moves all the points in the object in a straight line in the same direction. Students should know that not every transformation is a translation. • Students sometimes confuse the terms “transformation” and “translation”

		<p>Probing questions</p> <ul style="list-style-type: none"> • What strategies can I use to determine missing side lengths and areas of similar figures? • What is a dilation and how does this transformation affect a figure in the coordinate plane? <p>Differentiation Strategies</p> <p>Review the coordinate grid system and plotting points with students before starting to perform transformations.</p> <p>Advise students to fold the paper to get the correct reflection; use different colors for each new figure. Use fairly large grid paper (1/2 inch, or not less than 1 cm grid paper) to plot and to be able to see the new coordinates. Give students multiple choice options rather than open-ended problems to help them see choices, which they can eliminate as they work.</p> <p>Print pages from this website out and have the students compile them in a booklet. http://owensville.k12.mo.us/~smart_lessons/5/J.%20Mahurin/Math/Geometric%20Shapes/transformationandgraphing-sb.pdf</p> <p>Have students trace the original figure to be reflected or translated. Have them cut it out. They can then take the cut-out figure and reflect it or translate it. By using a physical figure, the students will be less likely to make errors and be able to get the right shape in their image because they can reflect it or translate it and then trace the figure. (Make sure they have labeled the cut out shape with the correct letters, which they can then transfer to the new image.)</p> <p>Literacy Strategies</p> <p>JOURNAL WRITING</p> <ul style="list-style-type: none"> • Explain why reflecting across the y-axis, causes the x coordinate to be the opposite of its image.
--	--	---

B. Similarity of Transformations

Understand congruence and similarity using physical models, transparencies, or geometry software.

MCC8.G.3 Describe the effect of dilations, translations, rotations, and reflections on two-dimensional figures using coordinates.

MCC8.G.4 Understand that a two-dimensional figure is similar to another if the second can be obtained from the first by a sequence of rotations, reflections, translations, and dilations; given two similar two-dimensional figures, describe a sequence that exhibits the similarity between them.

Essential Questions

- How can I tell if two figures are similar?
- In what ways can I represent the relationships that exist between similar figures using the scale factors, length ratios, and area ratios?
- Under what conditions are similar figures congruent?

Learning Targets

I can ...

- Describe the changes occurring to the x- and y- coordinates of a figure after a rotation, translations, reflection and/or dilation. (G3)
- Explain how transformations can be used to prove that two figures are similar. (G4)
- Describe a sequence of transformations to prove or disprove that two given figures are similar. (G4)

Concept Overview

Work in the coordinate plane should involve the movement of various polygons by addition, subtraction and multiplied changes of the coordinates. For example, add 3 to x, subtract 4 from y, combinations of changes to x and y, multiply coordinates by 2 then by 12. Students should observe and discuss such questions as ‘What happens to the polygon?’ and ‘What does making the change to all vertices do? Understandings should include generalizations about the changes that maintain size or maintain shape, as well as the changes that create distortions of the polygon (dilations). Example dilations should be analyzed by students to discover the movement from the origin and the subsequent change of edge lengths of the figures. Students should be asked to describe the transformations required to go from an original figure to a transformed figure (image). Provide opportunities for students to discuss the procedure used, whether different procedures can obtain the same results, and if there is a more efficient procedure to obtain the same results. Students need to learn to describe transformations with both words and numbers.

Through understanding symmetry and congruence, conclusions can be made about the relationships of line segments and angles with figures. Students should relate rigid motions to the concept of symmetry and to use them to prove congruence or similarity of two figures. Problem situations should require students to use this knowledge to solve for missing measures or to prove relationships. It is an expectation to be able to describe rigid motions with coordinates.

Vocabulary

- **Congruent:** Two plane or solid figures are congruent if one can be obtained from the other by rigid motion (a sequence of rotations, reflections, and translations).
- **Similar figures:** Figures that have the same shape but not necessarily the same size with congruent corresponding angles and proportional corresponding sides. One figure can be obtained from the other by uniformly scaling (enlarging or shrinking), possibly with additional translation, rotation and reflection.

Sample Problems

Sample Problems (MCC.8.G.3)

Sample Problem 1:

7. What is the scale factor of the dilation (with center at the origin) shown below?

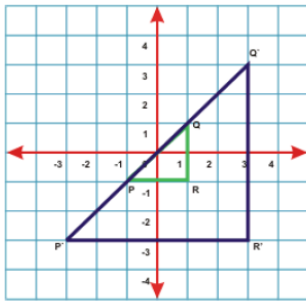

Answer: Scale factor is 3 times

Sample Problem 2:



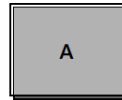

How many of the original rectangles can be created if the rectangle is scaled by 2 times?

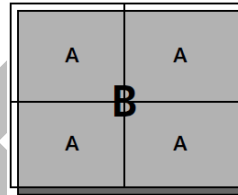



Answer: 4 original rectangles in the new dilated rectangle



Resources, Teacher Notes, and Instructional Strategies

Standard & Topic	Resources	Teacher Notes
<p>MCC.8.G.3 Dilations</p>	<p>Practice of Dilations in the Coordinate Plane. Resource type: Skill (S)</p> <p> DilationsinCP.pdf</p> <p> DilationsAndSimilarity.pdf</p> <p> DilationofItems.pdf</p> <p>State Learning Task(s) Dilations in a Coordinate Plane</p> <p> DilationsTask.docx</p>	<p>Student Misconceptions</p> <ul style="list-style-type: none"> Students may confuse additive thinking vs. multiplicative thinking. For example, suppose there were two similar rectangles with a pair of corresponding side lengths of 4 and 7 cm. The smaller similar rectangle has a width of 3 cm. A student may think the other corresponding side should have a length of 6 cm, because the first set of corresponding side lengths changed by 3 cm, so they might think that the other should also change by adding 3 cm. <p>Probing questions</p> <ul style="list-style-type: none"> What is a dilation and how does this transformation affect a figure in the coordinate plane? <p>Differentiation Strategies</p> <ul style="list-style-type: none"> Provide calculators. Provide labeled diagrams of all images used. Keep all diagrams in the same orientation. Provide grid paper for measurement instead of or in addition to standard rulers.

		<p>Cooperative Learning Strategies</p> <ul style="list-style-type: none"> Students will work with a partner to create a song/rap explaining dilations in a coordinate plane. <p>Literacy Strategies</p> <p>JOURNAL WRITING:</p> <p>What happens to a figure when it is dilated? What changes?</p>
<p>MCC.8.G.4 Similarity</p>	<p>Describe sequence of transformations to prove two figures are similar or congruent. (K), (S), (U). http://learnzillion.com/lessonsets/289</p> <p>Use as an exploration to confirm similarity. Resource type: Understanding (U)</p>  <p>Similarity Exploration.pdf</p> <p>Find missing values worksheet of similar figures. Resource type: Skill (S)</p>  <p>Similar Figures_Kuta.pdf</p>	<p>Student Misconceptions</p> <ul style="list-style-type: none"> Students confuse congruence with similarity. Students sometimes confuse the different kinds of notation used with similarity. A common misconception is that when the dimensions of an object are doubled, the area is doubled, too. Students may confuse additive thinking vs. multiplicative thinking. For example, suppose there were two similar rectangles with a pair of corresponding side lengths of 4 and 7 cm. The smaller similar rectangle has a width of 3 cm. A student may think the other corresponding side should have a length of 6 cm, because the first set of corresponding side lengths changed by 3 cm, so they might think that the other should also change by adding 3 cm. <p>Probing questions</p> <ul style="list-style-type: none"> What is a dilation and how does this transformation affect a figure in the coordinate plane? <p>Differentiation Strategies</p> <ul style="list-style-type: none"> Provide calculators. Provide labeled diagrams of all images used. Keep all diagrams in the same orientation. Provide grid paper for measurement instead of or in addition to standard rulers. Relations and sizes http://www.math.com/school/subject3/lessons/S3U3L2GL.html <p>Cooperative Learning Strategies</p> <p>VOCABULARY REVIEW</p> <ul style="list-style-type: none"> Students will create a crossword puzzle with their partner to exchange with another pair in

the class to complete.

Literacy Strategies

VOCABULARY REVIEW



VocabFoldDir.pdf

C. Proportional Parts of Parallel Lines with a Transversal

Understand congruence and similarity using physical models, transparencies, or geometry software.

MCC8.G.5 Use informal arguments to establish facts about the angle sum and exterior angle of triangles, about the angles created when parallel lines are cut by a transversal, and the angle-angle criterion for similarity of triangles. *For example, arrange three copies of the same triangle so that the three angles appear to form a line, and give an argument in terms of transversals why this is so.*

Essential Questions

- What strategies can I use to determine missing side lengths and areas of similar figures?
- When I draw a transversal through parallel lines, what are the special angle and segment relationships that occur?

Learning Targets

I can ...

- Informally prove that the sum of any triangle's interior angles will have the same measure as a straight angle (line) (i.e., by tearing off the three corners of a triangle and arranging them to form 180° straight angle. (G5)
- Make conjectures regarding the relationships and measurements of the angles created when two parallel lines are cut by a transversal. (G5)
- Apply proven relationships to establish minimal properties to justify similarity. E.g. Angle Angle Similarity of a Triangle (G5)

Concept Overview

Provide opportunities for students to physically manipulate figures to discover properties of similar and congruent figures, for example, the corresponding angles of similar figures are equal. Additionally use drawings of parallel lines cut by a transversal to investigate the relationship among the angles. For example, what information can be obtained by cutting between the two intersections and sliding one onto the other?



By using three copies of the same triangle labeled and placed so that the three different angles form a straight line, students can:

- explore the relationships of the angles,
- learn the types of angles (interior, exterior, alternate interior, alternate exterior, corresponding, same side interior, same side exterior), and
- explore the parallel lines, triangles and parallelograms formed.

Further examples can be explored to verify these relationships and demonstrate their relevance in real life.

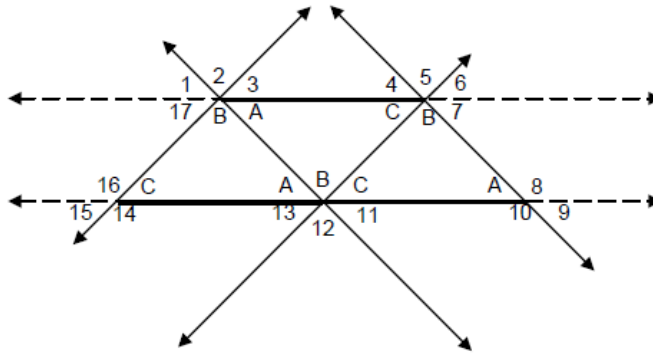

Investigations should also lead to the Angle-Angle criterion for similar triangles. For instance, pairs of students create two different triangles with one given angle measurement, then repeat with two given angle measurements and finally with three given angle measurements. Students observe and describe the relationship of the resulting triangles. As a class, conjectures lead to the generalization of the Angle-Angle criterion.

Vocabulary

- Interior angles: The inside angles of a polygon.
- Exterior angle: the angles that are adjacent to the interior angles and formed on the outside.
- Parallel Lines: Lines in the same plane that never intersect.
- Transversal: A line that intersects two or more lines at different points.

Sample Problems

Triangle LMN is similar to triangle XYZ.

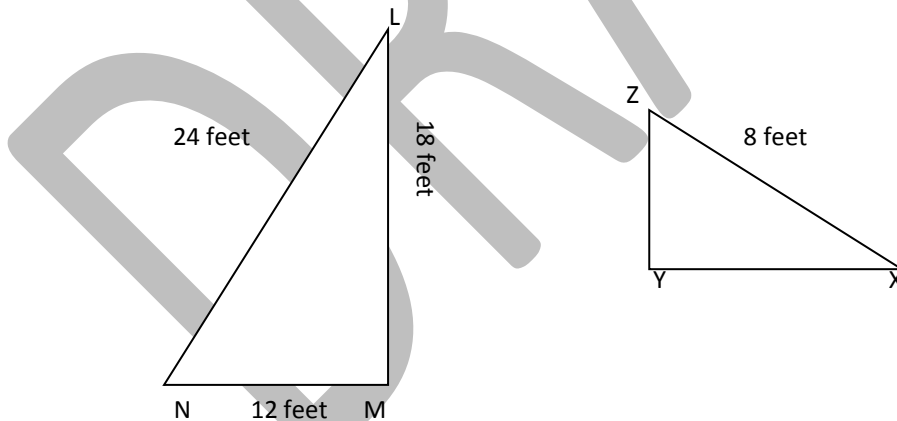

What is the length of \overline{YX} ?

- a) 2 feet b) 3 feet c) 4 feet d) 6 feet

Solution: C

Sample Problem

Triangle PQR is similar to triangle DEF as shown.

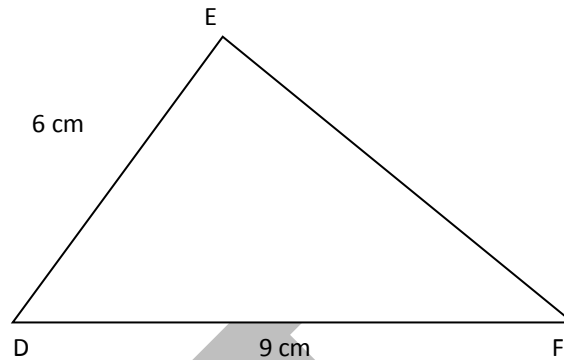
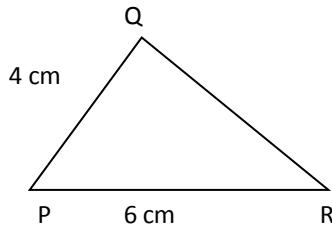

Which describes the relationship between the corresponding sides of the two triangles?

- a) $\frac{PQ}{DE} = \frac{4}{6}$ b) $\frac{PQ}{DE} = \frac{6}{4}$ c) $\frac{PQ}{EF} = \frac{4}{9}$ d) $\frac{PR}{DE} = \frac{6}{6}$

Solution: A

Sample Problem Answers are in GREEN

Calculate and write the angles next to each of the dots on the shapes below.

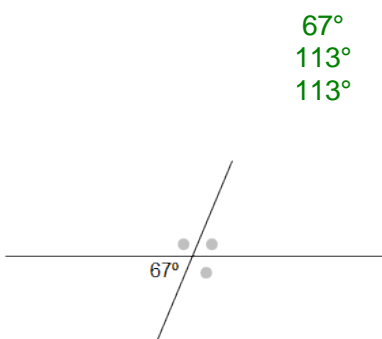

67°
113°
113°

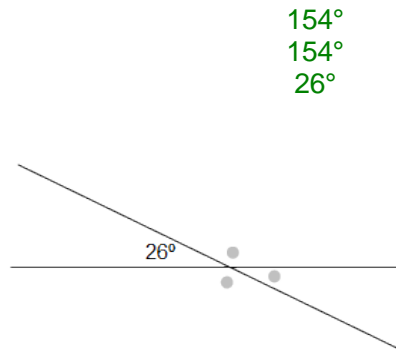

154°
154°
26°

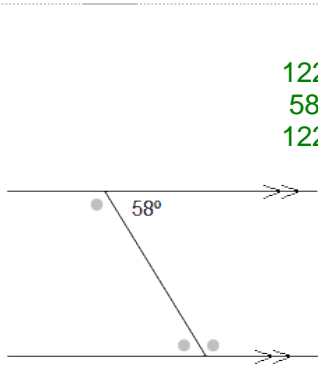

122°
58°
122°

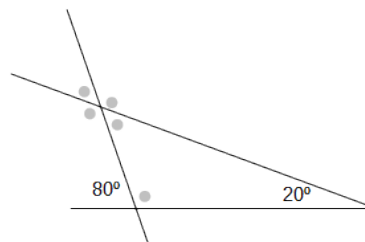





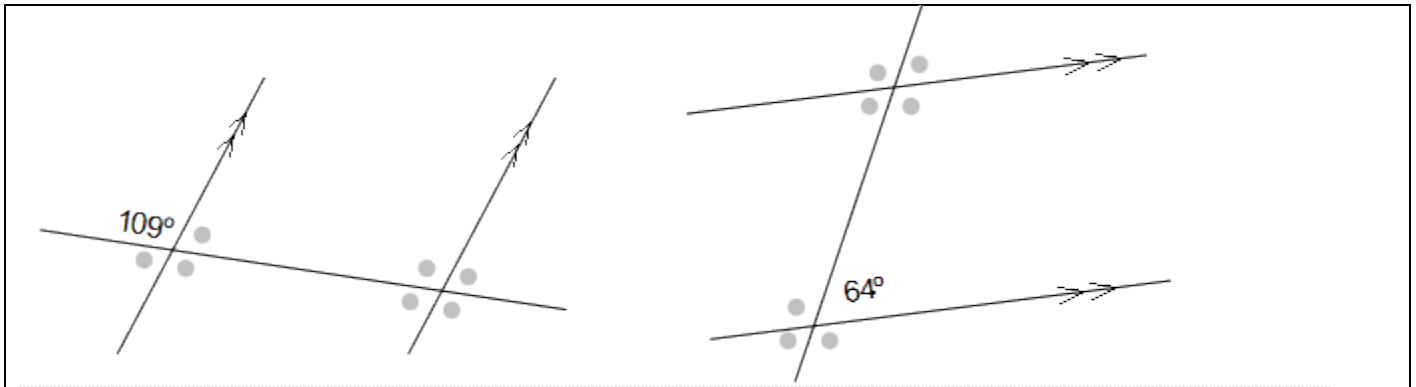

60°
120°
60°
120°
100°

71°
109°
71°
71°
109°
71°
109°

116°
116°
64°
64°
116°
64°
116°



Resources, Teacher Notes, and Instructional Strategies

Standard & Topic	Resources	Teacher Notes
<p>MCC.8.G.5 Angle Relationships</p>	<p>http://www.mytestbook.com/worksheet.aspx?testid=1308&grade=8&subject=Math&topics=Geometry%20Angle%20Relationship</p> <p>Understanding angle sum, exterior angles, angles created when parallel lines are cut by a transversal, and the angle-angle criterion for similarity of triangles</p> <p>http://learnzillion.com/lessonsets/115</p> <p>Parallel lines properties, postulates, and theorems. Resource type: Knowledge (K)</p> <p> Properties of Parallel Lines Cut by a Transv</p> <p>Explore the properties of constructed figures. <i>Must have Geometer Sketchpad software</i> Resource type: Understanding (U)</p> <p> introGSP.gsp  planegeometry.gsp</p> <p>Practice of parallel lines and proportions. Resource type: Skill (S)</p> <p> Parallel lines and proportionality practi</p>	<p>Model Lesson</p> <p> Week 5 Unit 1 Lesson Plan_Transfor</p> <p>Model Lesson</p> <p> 171_identifying_similar_triangles_complete.</p> <p> identifying_similar_triangles_slides_beta m</p> <p>Student Misconceptions</p> <p>Students may think...</p> <ul style="list-style-type: none"> • Students are unfamiliar with the symbolic notation used to identify angles and their measures. • Students may use the point of intersection to name all angles formed by a pair of intersecting lines. For example, all angles formed by a pair of lines that intersect at point A may be referred to as angle A. • Students confuse the terms supplementary and complementary. • Students believe that complementary and supplementary angles must be adjacent. • Students believe that all adjacent angles are either complementary or supplementary. • Students may incorrectly identify vertical angles. • Students will think that angles are congruent

State Learning Task(s)



Lunch Lines.docx



Similar Triangles Task.docx

when there are no parallel lines present. Emphasize that angles (alternate exterior, alternate interior, corresponding, and adjacent angles) can only be congruent when they are formed by parallel lines being intersected by a transversal.

- Students may be confused when the transversal is slanted differently.
- Students may be confused when the transversal is slanted differently. Exploring examples where the transversal is increasing from left to right and decreasing from left to right will help with this confusion.

Probing questions

- Why do I always get a special angle relationship when any two lines intersect?
- When I draw a transversal through parallel lines, what are the special angle and segment relationships that occur?

Differentiation Strategies

Check to see that students have basic understanding of vocabulary related to angles, such as vertex, rays and degrees.

Review the symbols used to notate angles and their measures. *For example, $m\angle ABC = 45^\circ$*

Ask students to predict angle measures before using protractors for actual measurement to prevent misreading the protractor.

Use graphic organizers, such as the Frayer model shown below, to support vocabulary development

Cooperative Learning Strategies

Students will work in partners to complete Lunch lines task

Literacy Strategies

JOURNAL WRITING

Explain the special angle-relationships that are formed when parallel lines are cut by a transversal.

Grade 8 Unit 1 Summative Assessment



SummativeAssessment_TransformationsC