

52 oz. MEDALLION

POP CLEAN POPPER

Instruction Manual

Models #2911, 2948, 2960, 2972



Downdraft



Updraft

 **GOLD MEDAL**®

FUNFOOD EQUIPMENT & SUPPLIES

Cincinnati, OH 45241-4807 USA

SAFETY PRECAUTIONS



⚠ DANGER

Machine **MUST** be properly grounded to prevent electrical shock to personnel. Failure to do so could result in serious injury, or death. Do **NOT** immerse the kettle, warmer, or any other part of this equipment in water. Always unplug the equipment before cleaning or servicing. Do not use excessive water when cleaning.



⚠ WARNING

To avoid serious burns, do **NOT** touch the kettle while it is hot.



⚠ WARNING

ALWAYS wear safety glasses when servicing this equipment.



⚠ WARNING

Any alterations to this equipment will void the warranty and may cause a dangerous situation. **NEVER** make alterations to the equipment. Make sure all machine switches are in the off position before plugging the equipment into the receptacle.



⚠ CAUTION

Do **NOT** allow direct contact with this equipment and the general public when used in food service locations. Only personnel that are trained and familiar with the equipment should operate the equipment. Carefully read all installation instructions before operation.



⚠ CAUTION

This machine is **NOT** to be operated by minors. Minors are classified as anyone under the age of 18.

NOTE

The information, specifications and illustrations contained in this manual represent the latest data available at time of publication. Right is reserved to make changes as required at the discretion of Gold Medal Products Company without notice.

Domestic - 120/208V or 120/240V, 60 HZ, 8626 Watts

Export - 240V, 50HZ

Agency Approvals: ETL, cETL, ETLs

Note: Fire suppression components are in accordance with ANSUL R-102 specifications and tested and approved by ETL to U.L. Standard 710B. Units not equipped with fire suppression should be approved by local agencies.

INSTALLATION INSTRUCTIONS

CHECKING SHIPMENT

Unpack all cartons and check thoroughly for any damage that may have occurred during transit. Damage claims should be filed immediately with the transportation company.

Domestic models only: 120v/208v or 120v/240v 60 Hz.

A 50 amp – 4 wire wall receptacle is shipped with each machine. This receptacle will accept the attachment plug on the popper and must be used. Your electrician must furnish sufficient current for proper operation of your machine. We recommend this popper be on a dedicated and circuit protected line. (note: The Medallion “uses” both “hot to neutral” legs, 120v. The machine does not “use” the 208v or 240v, “hot to hot” connection.

	⚠ DANGER
	<p>Machine must be properly grounded to prevent shock in case of electrical problems. Wall receptacle must be wired as shown on the receptacle. Failure to wire properly will void the warranty and can result in damage to motors, elements, relay, lights, etc.</p>

Fire Suppression models only.

The pop clean poppers with fire suppression systems must be installed with a minimum 6” clearance to combustible surfaces on the operator’s side and top of the machine. In the case of a Pass-Thru configuration, the 6” clearance applies to both the front and back and top of the machine.

Note: Machine will not operate until the ANSUL system has been charged and activated by an ANSUL representative. For a local representative go to www.Ansul.com.

⚠ WARNING

<p>To avoid serious burns, do NOT touch the kettle while it is hot!</p>

FINAL PREPARATIONS

The popcorn machine was adjusted, inspected, and tested before it left the factory.

Connect the clear oil line from the pump to the aluminum line from the popper with the supplied hose clamp. Connect the 6 pin connector from the popper to the receptacle on the oil pump. Both Bucket pump (2114 or 2114EX) and Bag-in-a-Box pump (2257 or 2257X) have the same receptacle.

Follow the instructions provided in the oil pump manual to set the oil delivery amount. The proper amount of oil for the 52oz. Medallion is between 15oz. to 17oz.

To check for proper amount of oil, and assure oil is liquid, dispense a “shot” into a measuring cup.

OPERATING INSTRUCTIONS

CONTROLS AND THEIR FUNCTIONS

POP CLEAN FILTER SYSTEM –
Operates the exhaust blower and initializes a check of the filter interlocks and pressure switches. **Note: Kettle Heat switch is inactive unless this switch is on and all filters are in place.**

BAFFLE FILTER LIGHT – Light is on if baffle filter is in place. **Note: Kettle Heat switch is inactive unless this light is on.**

BAG FILTER LIGHT – Light is on if bag filter is in place. **Note: Kettle Heat switch is inactive unless this light is on.**

HEPA FILTER LIGHT – Light is on if HEPA filter is in place. **Note: Kettle Heat switch is inactive unless this light is on.**

CHANGE FILTERS LIGHT – Light is on when bag and HEPA filter efficiency is reduced to less than 75%. **Note: Kettle Heat switch is inactive if this light is on.**

FIRE SUPPRESSION SYSTEM ARMED (IF EQUIPPED) – Light is on if fire suppression system is charged and activated. **Note: Machine will not operate until the ANSUL system has been charged and activated by an ANSUL representative.**

CHECK FILTERS LIGHT – Light is on when bag and HEPA filter efficiency is reduced to less than 80%. The Bag and HEPA Filters should be checked and one or both should be changed as needed.

LOAD SELECTOR (FLEXI-POP SWITCH IF EQUIPPED) - Changes energy to kettle for the load switch from 52 oz to 32 oz. It automatically adjusts the oil amount on the 2257D. The Green cup is for the 52 oz and the Blue cup is for the 32 oz.

LIGHT SWITCH - Operates all the lights, interior and dome, on your popcorn machine.

OIL SYSTEM MASTER SWITCH - Sends power to the oil pump, either the Bucket Pump or Bag-in-a-Box models. The warmer/blower on the oil pump is activated. The warmer/blower on the oil pump will keep coconut popping oil liquid if the doors on the base are kept closed. It may be desirable to keep this switch on at night, if you have problems keeping the coconut oil liquid. Coconut oil will congeal at temperatures below approximately 76° F [24° C].

WARMER SWITCH - Operates the blower and warmer in the corn storage area. Keeps popped corn warm.

SALT-SWEET SWITCH (IF EQUIPPED) - Changes the temperature 50°F lower for the sweet option.

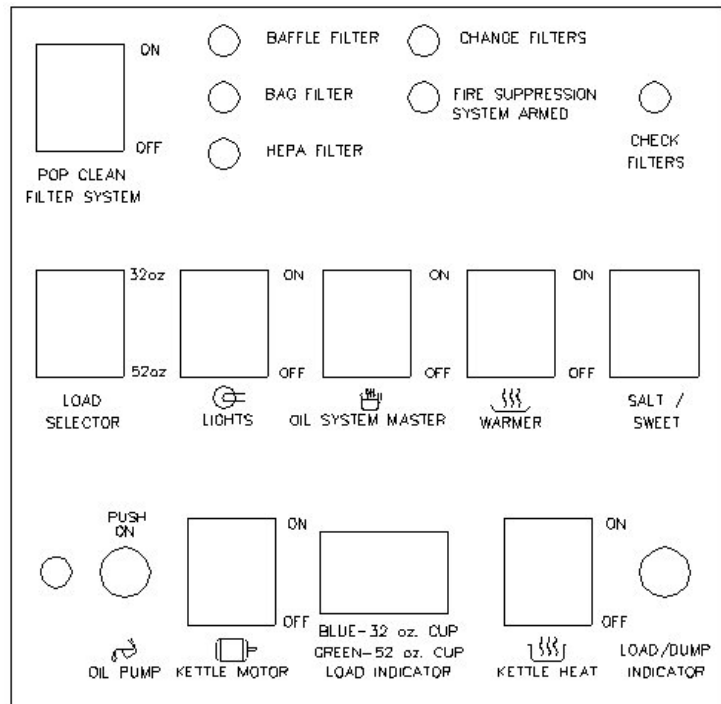

“RED” OIL DISPENSE MOMENTARY SWITCH - When pushed, will dispense the predetermined amount of oil into the kettle.

KETTLE MOTOR - Operates the kettle agitator motor.

LOAD INDICATOR LIGHT (FLEXI-POP IF EQUIPPED) - Indicates the current load setting of 52 oz or 32 oz.

KETTLE HEAT SWITCH - Operates the heating elements in the popping kettle.

LOAD/DUMP INDICATOR (YELLOW LIGHT & AUDIBLE SIGNAL) - Alerts the operator to:

1. Load the corn and oil *or*
2. Dump the popped corn from the kettle *or*
3. Turn off the kettle heat switch if they are done popping corn

POPPING CORN

1. Turn on the Pop Clean Filter System switch first. If the Baffle, Bag and HEPA filter lights are all green and the change filter light is not lit, then proceed to the next step. If any of the filter lights are not lit, check to see if those filters are in place. If the check filter is lit, change the appropriate filter.
2. Turn on all remaining switches.
3. When popping with coconut oil, be sure the oil is liquid. Dispense oil into a measuring cup first (should be between 15 oz. to 17.5 oz.), and then use that oil for the first popping cycle.
4. When the kettle is ready (about 5-8 minutes), the Yellow Light and Audible Signal will turn on. Lift the kettle lid and pour in 52 oz. of corn (use the supplied corn cup) and 8 teaspoons (21 cc) of Flavacol. Close lid.
5. Press the RED oil pump button. The proper amount of oil is pumped into the kettle. The Light and Signal will turn off.
6. When the popcorn has completed popping, the Light and Signal will turn on. Dump the Popcorn.
7. On the final kettle of corn, turn the “KETTLE HEAT” switch off, just as the lids are forced open by the popping corn. This saves electricity.

REMEMBER:

If the Yellow Load - Dump light is turned on and the Signal is sounding *one of the* following actions should be taken:

1. Load the corn and oil *or*
2. Dump the popped corn from the kettle *or*
3. Turn off the kettle heat switch if you are done popping corn

When you are finished popping, make sure “KETTLE HEAT” and “KETTLE MOTOR” switches are turned “OFF”.

NEVER LEAVE THE HEAT ON WHEN YOU ARE NOT POPPING.

CLEANING INSTRUCTIONS

Clean the Kettle

1. As you pop corn, wipe the kettle with a clean cloth. It is easy to keep the outside clean when the kettle is warm and the oil is not baked on. **CAUTION:** The hot kettle will cause burns if you touch it with your hand.
2. Every night, mix a gallon of Heat'n Kleen solution (2 tablespoons per gallon of water). Turn on the kettle heat. When the water starts to boil, turn off the heat and let it work overnight.
3. The next morning, dump the solution in a bucket and wipe the inside of the kettle with a cloth.
4. A CLEAN-IN-PLACE hook is located behind the operator side kettle support arm. Just tilt the kettle to the dump position, and swing the hook into position to hold the kettle in the dumped position. This feature will help you clean the kettle.

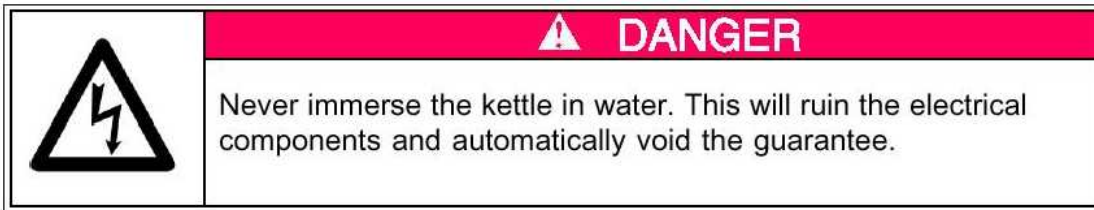

Clean the Popcorn Machine

1. Wipe the stainless steel parts with a clean cloth and cleaner designed for stainless steel. **Do not use oven cleaners, as they will damage parts of the machine.**
2. Ammonia cleaners will damage the plastic doors. Use only non-ammonia cleaners.

Clean the Baffle Filter

1. Lift the baffle filter towards the top of the popper. Swing the bottom end clear of the mounting brackets and remove the filter. Clean the filter in warm soapy water, allow to air dry, then replace. Do not attempt to clean the bag, or HEPA filters.

Box and HEPA Filters:

1. Note: The bag, and HEPA filters are not to be cleaned. When then “**check filter**” light comes on, be prepared to change either the bag filter – or the HEPA filter. (The HEPA filter should last twice as long as the bag filter.) When the “**change filter**” light comes on, the machine will be inoperable until the bag and/or HEPA filter is replaced.

Clean the Warmer Compartment

1. This element will be covered underneath corn pan inside the warming assembly. For proper operation, you **MUST** remove cover and clean underneath the element every 3-4 months. Be sure machine is off and power is disconnected before cleaning

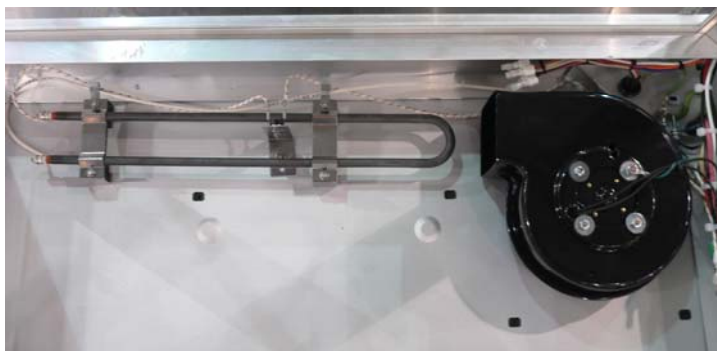

Filters for Downdraft Models

Item No.	Part No.	Description
1	62709	Baffle filter
2	62710	Box Filter
3	62711	HEPA Filter
4	63300	Filter Plug



Baffle Filter

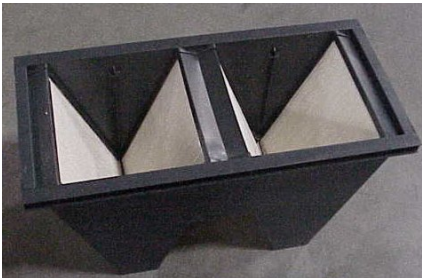

Box Filter



HEPA Filter



Filter Plug



Filter Plug Installed

Filters for Updraft Models

Item No.	Part No.	Description
1	63222	Baffle filter
2	63304	Box Filter
3	62711	HEPA Filter



Baffle Filter



Box Filter



HEPA Filter

Filter Access – Downdraft Models



Filter Life

Baffle Filter – Life of the popper
 Box Filter – 2 to 6 months
 HEPA Filter – 6 months to 1 year

Baffle Filter

Slide filter towards top end. Swing bottom end of filter clear of retainer clips and remove filter.

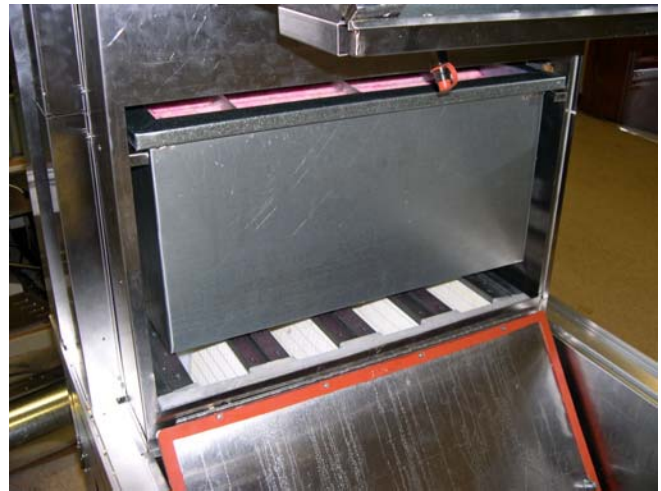

Bag and HEPA Filter

Loosen three door latches by rotating counterclockwise and open access door. Slide bag filter towards opening to remove. Lift HEPA filter up until it clears the door opening and remove.

Note: All filters must be in place before the Kettle Heat switch will be active.

Filter Access – Updraft Models



Filter Life

Baffle Filter – Life of the popper

Box Filter – 2 to 6 months

HEPA Filter – 6 months to 1 year

Baffle Filter

Slide filter towards top end. Swing bottom end of filter clear of retainer clips and remove filter.

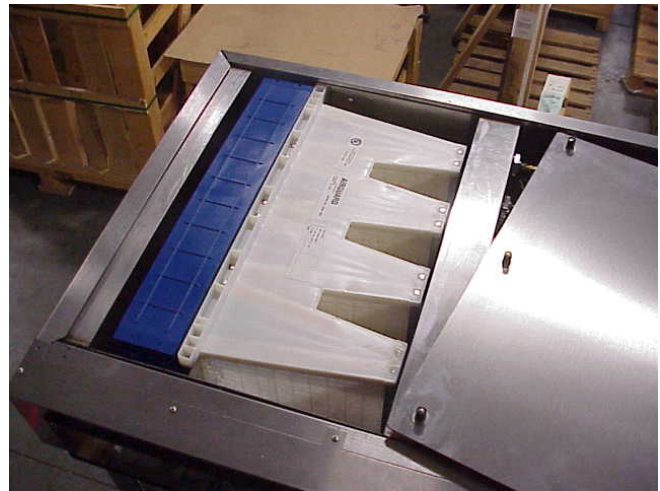
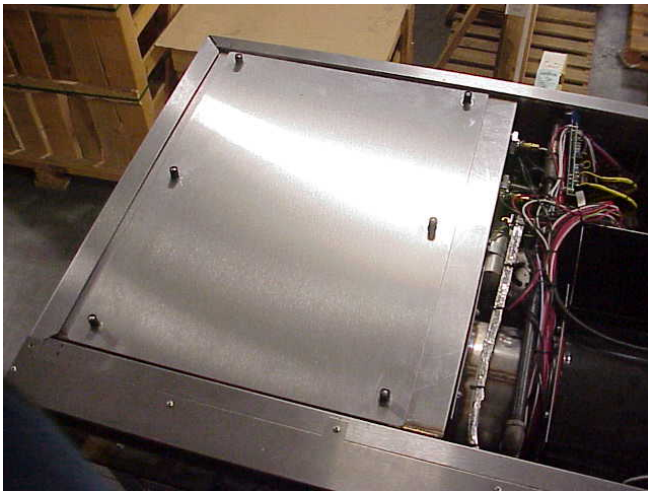

Bag and HEPA Filter

Loosen three door latches by rotating counterclockwise and open access door. Slide bag filter towards opening to remove. Lift HEPA filter up until it clears the door opening and remove.

Note: All filters must be in place before the Kettle Heat switch will be active.

Electronic Temperature Control

Operation

The control is factory set to 460F – 480F, which stops power to the kettle when the thermocouple reaches 460F – 480F. On the Medallion machine, this is also the ideal point to dump the popped corn out of the kettle. On the first start-up this is also the ideal time to load the corn and oil. Therefore if the kettle heat switch is turned on and the buzzer is sounding *one of the* following actions should be taken:

- Load the corn and oil *or*
- Dump the popped corn from the kettle *or*
- Turn off the kettle heat switch if you are done popping corn

Adjustment of Electronic Control

The Medallion has an electronic kettle control with 2 thermocouples, one for control and one for limit. There are no mechanical thermostats in this kettle.

There are (4) factory adjustments on the control:

1. Control temperature – **do not** adjust this one
2. Signal to dump – If you want the signal to dump to be a little sooner or later you can adjust the potentiometer marked “kettle dump”. CW is sooner, CCW is later.
3. The patented overshoot circuit is tuned for the kettle, **do not** adjust this potentiometer.
4. The audible signal to dump has three options; full volume, half volume, no sound (just the yellow light). Adjustments are by jumper positions. We ship full volume.

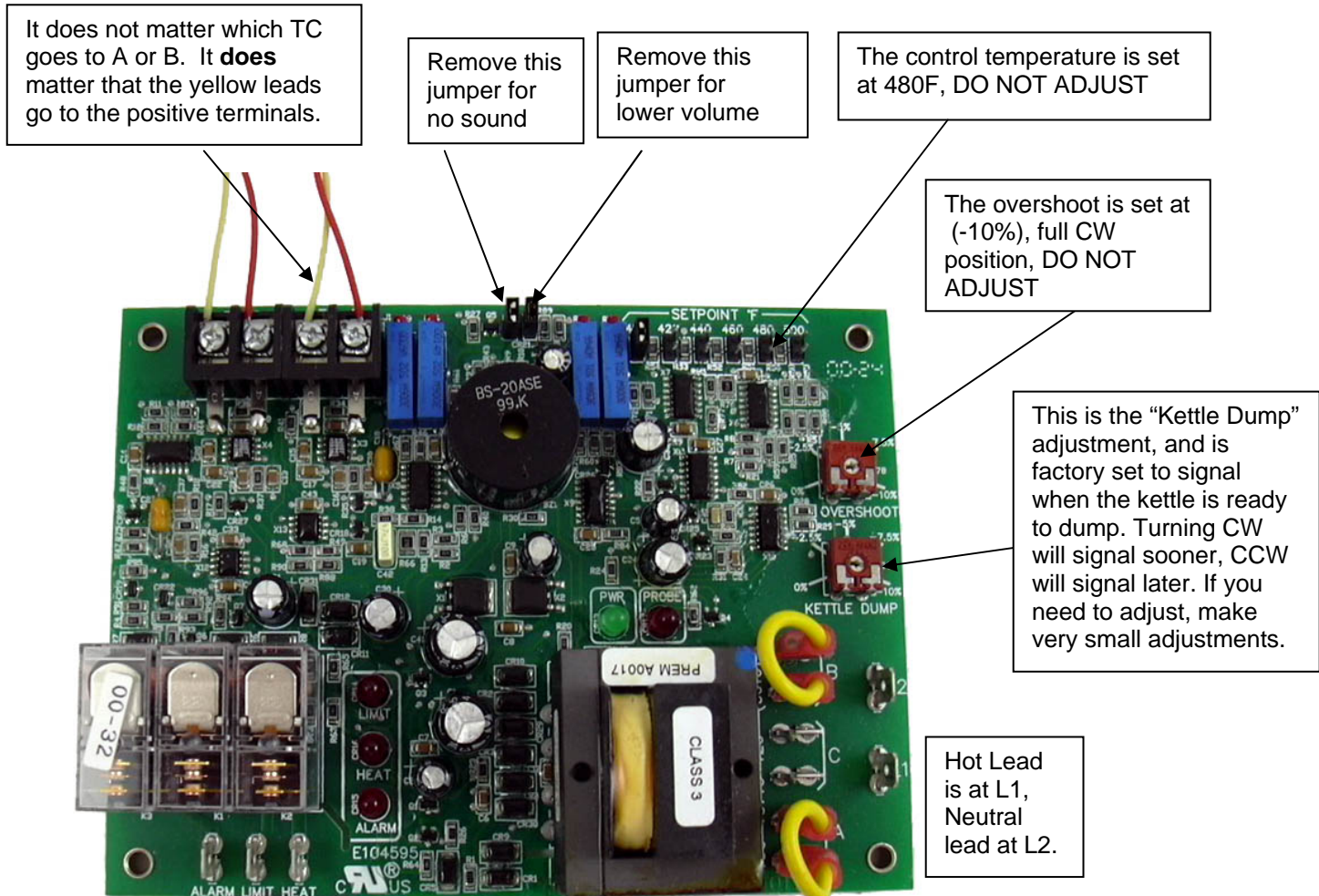

MAINTENANCE INSTRUCTIONS

	⚠ CAUTION
	THE FOLLOWING SECTIONS OF THIS MANUAL ARE INTENDED ONLY FOR QUALIFIED SERVICE PERSONNEL WHO ARE FAMILIAR WITH ELECTRICAL EQUIPMENT. THESE ARE NOT INTENDED FOR THE OPERATOR.

	⚠ WARNING
	Adequate eye protection must be used when servicing this equipment to prevent the possibility of injury.

	⚠ DANGER
	Do NOT immerse the kettle, warmer, or any other part of this equipment in water. Unplug your machine before servicing.

NOTE

We do not ship glass. Obtain from local glass shop or hardware store. Always purchase double strength type glass.

Setting the Amount of Popping Oil with a Gold Medal BIB System

If your BIB pump was manufactured prior to March 2003, the oil dispense time is adjusted by setting a timer that controls how long the pump operates. This system is model number 2257H. To adjust the oil amount, follow these instructions:

STEP 1:

Remove the (2) screws that attach the cover plate on the BIB unit as shown.

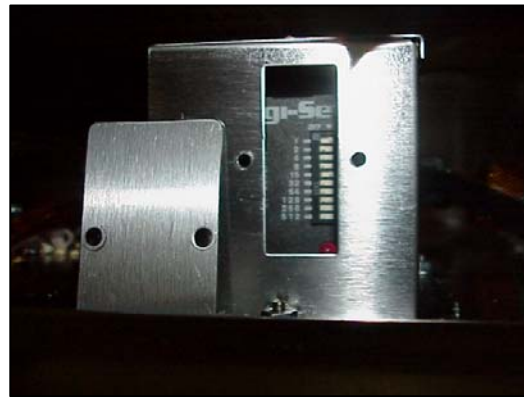
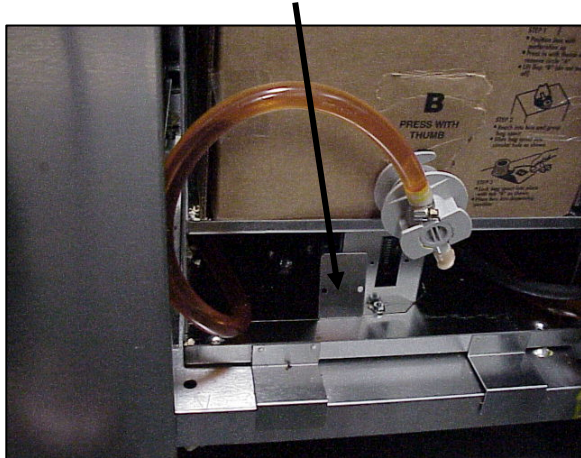

View of Timer for Pump

STEP 2:

Verify the current amount of oil charge. Using a measuring cup, push the oil dispense button (red) on the popper and note the amount of oil dispensed.

STEP 3:

The amount of oil dispensed is determined by how long the pump is on. The Timer shown is set as follows.



For each switch in the “on” position, add the numbers together for the total number of seconds the pump operates.

Example:

The setting on the pump timer shown has switches 1,2,8 on, and all others, off. So add $1+2+8$ for a total of 11 seconds.

(As a “rule of thumb”, 1 second is about 1 ounce of oil.)

So if you want to add 2 ounces of oil to the setting shown, you would start with 13 seconds. Since $8+4+1=13$, then slide those switches to “on”, and all others to “off”.

Note that the total seconds is not exactly the total amount of oil dispensed, but you can use the “rule of thumb” 1 second=1 ounce oil for adding or subtracting to your current oil amount.

STEP 4:

Repeat step 2, and record the amount. Adjust again as necessary.

Setting the Amount of Popping Oil with a Gold Medal BIB System

In March 2003, we introduced the model 2257 with the E-Z Set control.

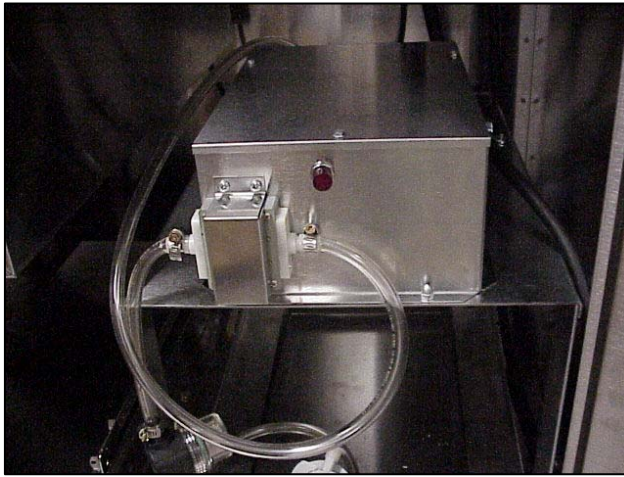

With this system, it is not necessary to set a timer. To adjust the oil amount, follow these instructions:

Holding the RED *Oil Dispense* push button (on the popper) down while turning on the *Oil System Master* switch (on the popper) puts the unit in the program mode. The oil light (on the popper) will start to blink off and on indicating that the timer is in the program mode.

When in the program mode, press and release the oil *Dispense* switch to start the oil flowing. When the correct amount of oil has been dispensed into the measuring cup, push the oil *Dispense* switch again to stop the oil flow. The oil amount can be “topped off” by pushing the oil *Dispense* switch on/off as many times as needed to finalize the oil amount. Turning the *Oil System Master* switch off and then back on puts the unit in the regular mode. The unit will now dispense the “programmed” amount of oil when the oil *Dispense* switch is pushed. The oil light will light only when the oil pump is on.

You will need to perform this procedure with the oil lines full of oil. Otherwise, you are setting both the amount of oil that goes in the kettle plus the amount of oil to fill the lines. Just fill the lines using the process above, then reset the amount as described above.

NOTES:

Model 2257D has the capability of “remembering” two different settings for poppers with the “Salt/Sweet” option or “Flexi-Pop” option.

- For Salt/Sweet models, just put the switch in the “salt” position, and set the oil amount as described above. Then put the switch in the “sweet” position and repeat the setting procedure. The pump will remember both settings.
- For Flexi-Pop models, just put the “Load” switch in one position, 32oz. for example, then set the oil amount. Then put the load switch in the other position, 18oz. for example. And repeat the setting procedure.
- Model 2457 is the heated line option for the 2257 pump.

TROUBLESHOOTING

LONG POPPING CYCLES

If your pop cycle is longer than 4 minutes, it can be the result of several things:

- A. **LOW VOLTAGE** - If the machine is operated on low voltage, this could cause the kettle not to reach the proper operating temperature. Voltage for each leg, with kettle turned on, must be at least 110v.
- B. **INADEQUATE SUPPLY LINES** - Inadequately sized electrical supply lines, in addition to being a fire hazard, would also prevent the kettle from reaching the proper operating temperature. Check with a qualified electrician.
- C. **INFERIOR CORN** - Inferior quality corn would result in longer popping cycles. Use only top quality hybrid popcorn from reputable suppliers. Even then, if you let your corn pick up moisture or dry out, your popping cycles will be slow.

KETTLE DOES NOT HEAT

Before you go any further, make sure the kettle lead-in cord is plugged in, and that circuit breakers are not tripped. Make sure all electrical connections are tight.

- A. **KETTLE HEAT SWITCH** - Check the voltage to and from the “KETTLE HEAT” switch, and if the switch is defective replace it.
- B. **CONTROL** - A defective thermocouple lead will cause the kettle not to heat. Check for good connections from the kettle to the control.
- C. **POWER RELAYS** – Check to see if the two power relays operate. Both relays should operate with the kettle heat switch on. If the relays do not both operate, look at the status of the LED’s on the heat control PCB.
 - Green LED “on” – power is going to the heat control (kettle heat switch is on)
 - Probe LED “on” – one or both thermocouples are open or not properly connected to the heat control board.
 - Limit LED “on” – normal operation. The limit power relay should be “picked up”.
 - Heat LED “on” – normal operation. (If the kettle temperature is at or above set point, LED will be off) The heat power relay should be “picked up”
 - Alarm LED “off” – normal operation. The LED turns on when the kettle reaches the set dump temperature.

MOTOR WILL NOT TURN AGITATOR

WARNING! If the kettle agitator shaft is not rotating, do not pop corn.

Adjust the clearance between the kettle bottom and the stir blade to 1/32”. (use a dime)

Loosen the set screw in the collars above and below the crossbar and adjust the agitator shaft as necessary. Then re-tighten the set screws in the collars.

OIL PUMP DOES NOT DELIVER OIL TO KETTLE

If the pump is operating but oil is not dispensed, the oil may be solid in the oil lines. If the pump is not operating see the pump manual for instructions.

ORDERING SPARE PARTS

1. Identify the needed part by checking it against the photos, illustrations, and/or the parts list.
2. When ordering, please include part number, part name, and quantity needed.
3. Please include the machine's model name, serial number, and date of manufacture (located on the machine nameplate) with your order.
4. Address all parts orders to:

Parts Department
Gold Medal Products Co.
10700 Medallion Drive
Cincinnati, Ohio 45241-4807
(800) 543-0862
(513) 769-7676
Fax: (513) 769-8500

or, place orders at:

Web Page: www.gmpopcorn.com

E-mail: info@gmpopcorn.com

CABINET LIST

Item No	Part No	Description
	Downdraft	36" Updraft
1	37513	37513 SWIVEL CASTER
2	37514	37514 NSF SWIVEL CSTR W/LOCK
3	41349	41349 MALE HINGE SHORT LEFT
4	41350	41350 MALE HINGE SHORT RIGHT
5	41354	41354 FEMALE HINGE RIGHT
6	41355	41355 FEMALE HINGE LEFT
7	46511	63416 DRAWER SLIDE, WELD ASSY
8	46512	63416 DRAWER SLIDE, WELD ASSY
9	62746	63289 DRIP TRAY
10	50013	50013 MAGNET
11	67069	67069 HANDLE
12	82031	82031 CORN BIN ASSY
13	82102	82102 LID CORN BIN
14	82103	82103 GUSSET SUPPORT CASTER
15	82280	N/A MT ANGLE, CORN BIN SLIDE
16	82281	N/A MT ANGLE, CORN BIN SLIDE
17	82698	82698 FLUSH MOUNT HANDLE
18	83050	83050 DOOR CATCH BRACKET
19	82035	N/A RETAINER ASSY

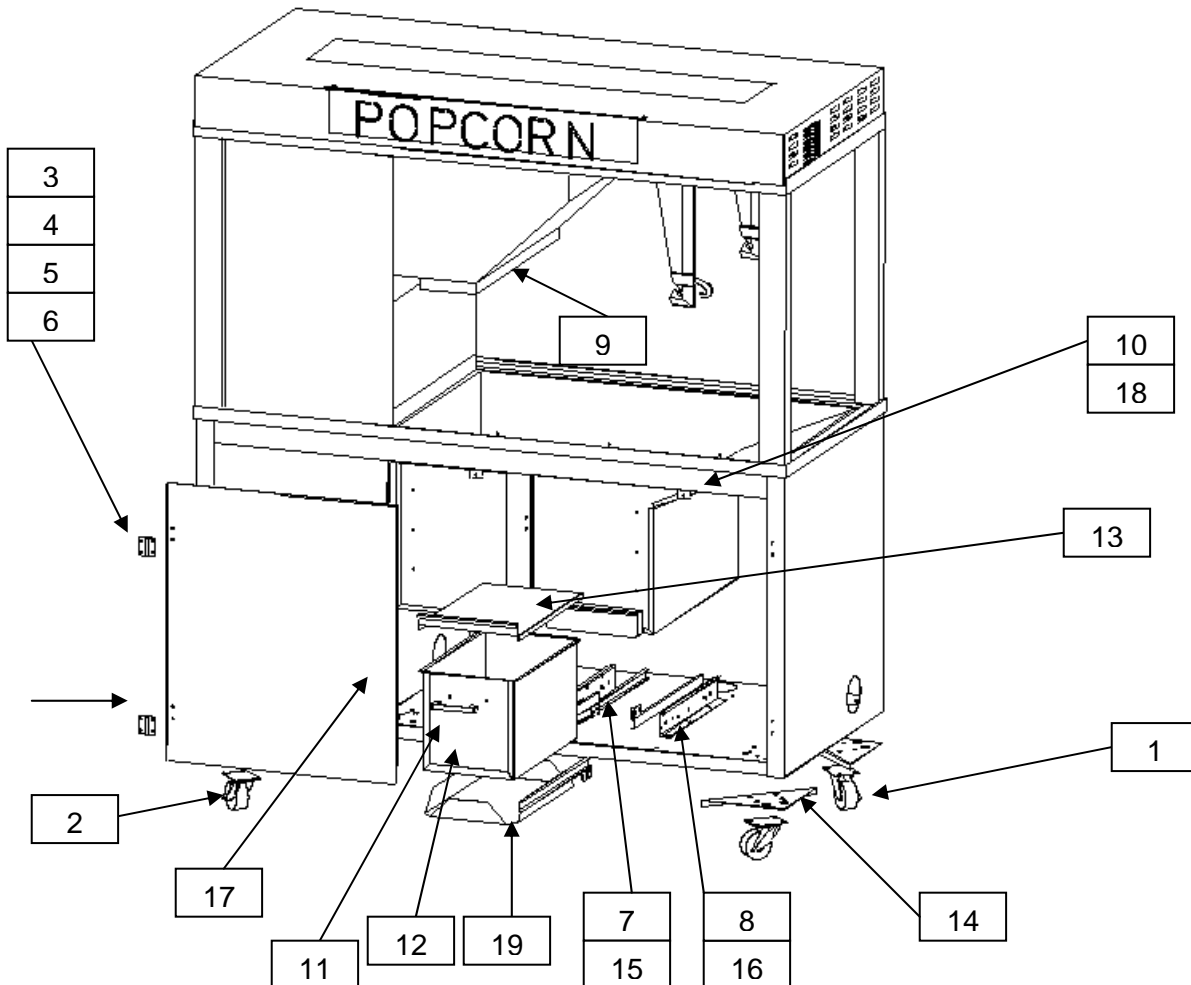

INSIDE CABINET LIST

Item No	Part No	Description
1	41380	SPUR GEAR
2	41432	GEAR BLOCK ASSY
3		
4	47799	LIGHT SHIELD ANGLE
5	48907	HANGER ARM ASSY
6	48908	HANGER ARM ASSY CIP
7	49480	LIGHT SHIELD CONICAL
8	43426	KETTLE RETAINER
9	12319	KNOB, GEAR LOCK

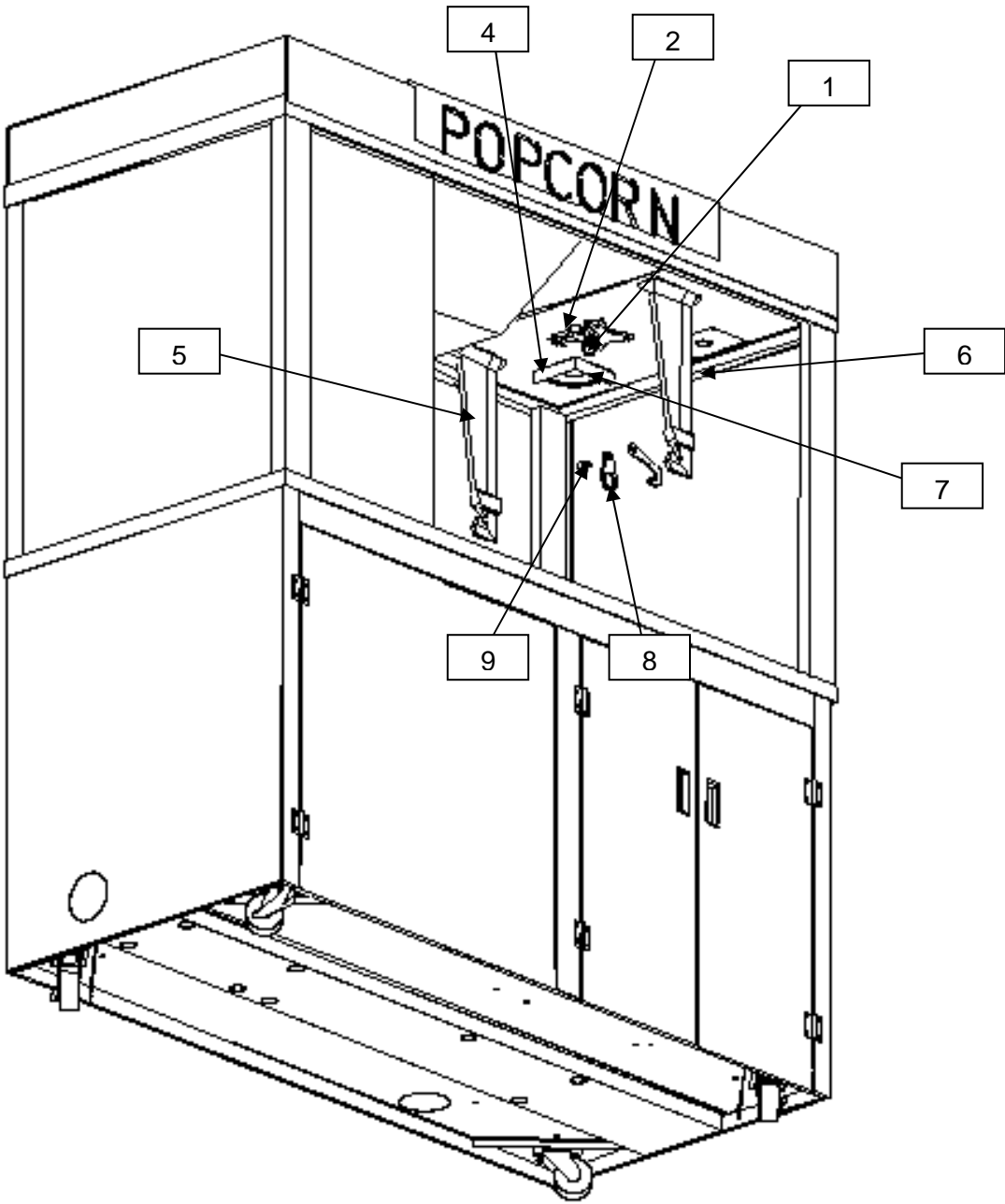

DEEP WELL LIST

Downdraft 36" Updraft

Item No	Part No	Part No	Description
1	62092	62092	OLD MAID PAN
2	67069	67069	HANDLE
3	SEE CHART	SEE CHART	OLD MAID SCREEN ASSY
4	SEE CHART	SEE CHART	BLOWER COVER
5	SEE CHART	SEE CHART	DIFFUSER COVER
6	61123	61123	BLOWER, 120V
	61124	61124	BLOWER, 230V (EXPORT)
7	61128	61128	HEAT ELEMENT 120V, 800W
	61135	61135	HEAT ELEMENT 230V, 800W (EXPORT)
8	61133	61133	HEATER CLAMP
9	61134	61134	HEATER MOUNT
10	47385	47385	THERMOSTAT WARMER
	74748	74748	THERMOSTAT WARMER (EXPORT)
11	47548	47548	MOUNTING ANGLE

DOWNDRAFT	UPDRAFT
36"	63264
48" - 62912	61139
60" - 61139	61139
72" - 61139	61139

DOWNDRAFT	UPDRAFT
36"	61146
48" - 62911	82944
60" - 82944	82736
72" - 82736	82750

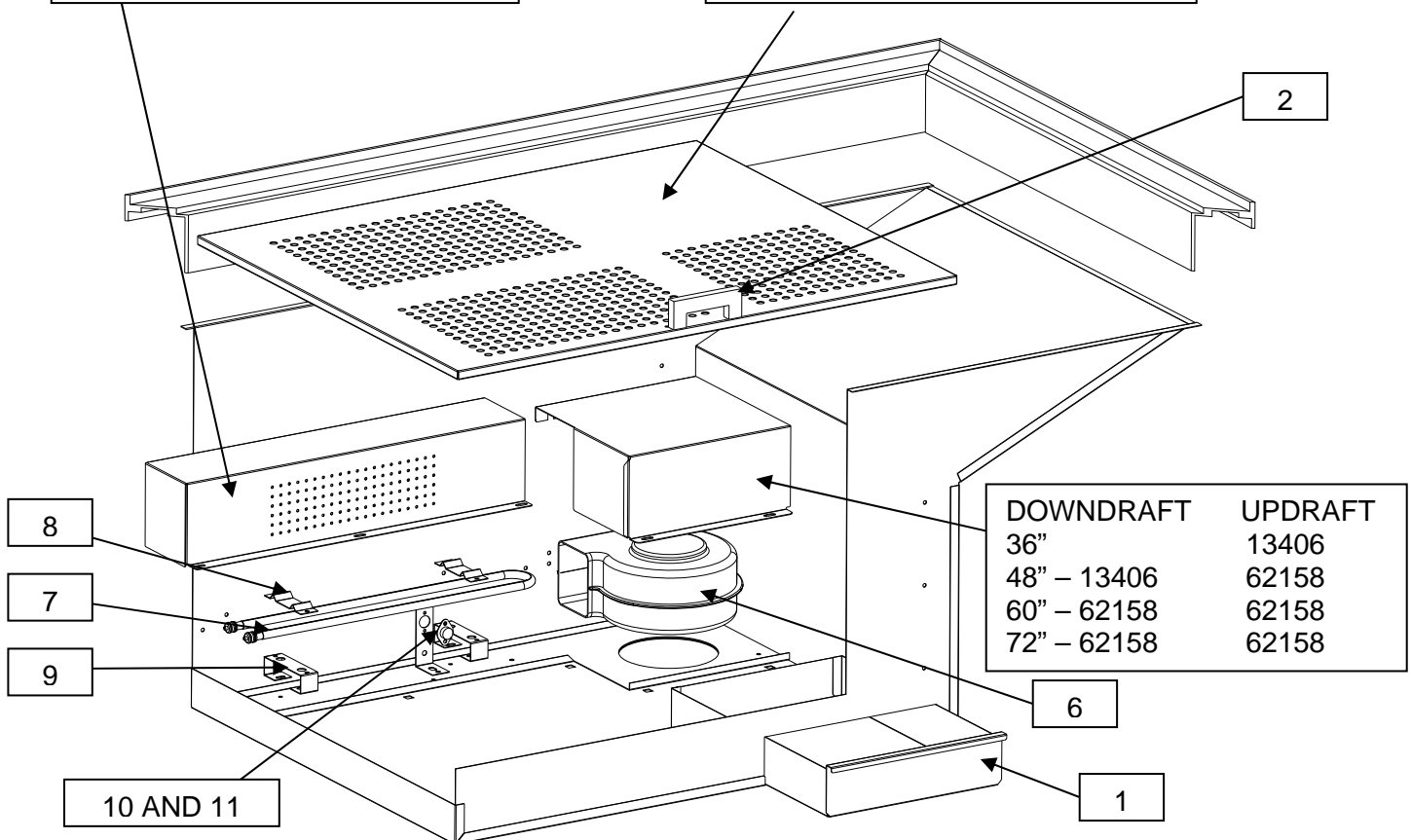

DOWNDRAFT	UPDRAFT
36"	13406
48" - 13406	62158
60" - 62158	62158
72" - 62158	62158

KETTLE BOTTOM LIST

Item No	Part No	Description
1	41434	RETAINING NUT
2	46491	HEAT ELEMENT 120V,2700W
3	46498	HEAT ELEMENT 240V,2700W (EXPORT)
4	48650	TUBULAR ELEMENT, 120V 1800W
5	48650EX	TUBULAR ELEMENT, 240V 1800W (EXPORT)
6	48651	TUBULAR ELEMENT, 120V 1050W
7	48651EX	TUBULAR ELEMENT, 240V 1050W (EXPORT)
8	48958	KETTLE GASKET
9	48968	HEAT TRANSFER PLATE
10	61072	WHITE WIRE ASSY
11	61073	WHITE WIRE ASSY
12	61074	WHITE WIRE ASSY
13	61075	RED WIRE ASSY
14	61076	GREEN WIRE ASSY
15	61077	BLACK WIRE ASSY
16	61078	BLACK WIRE ASSY
17	82595	48,52,66OZ ELEMENT CLAMP

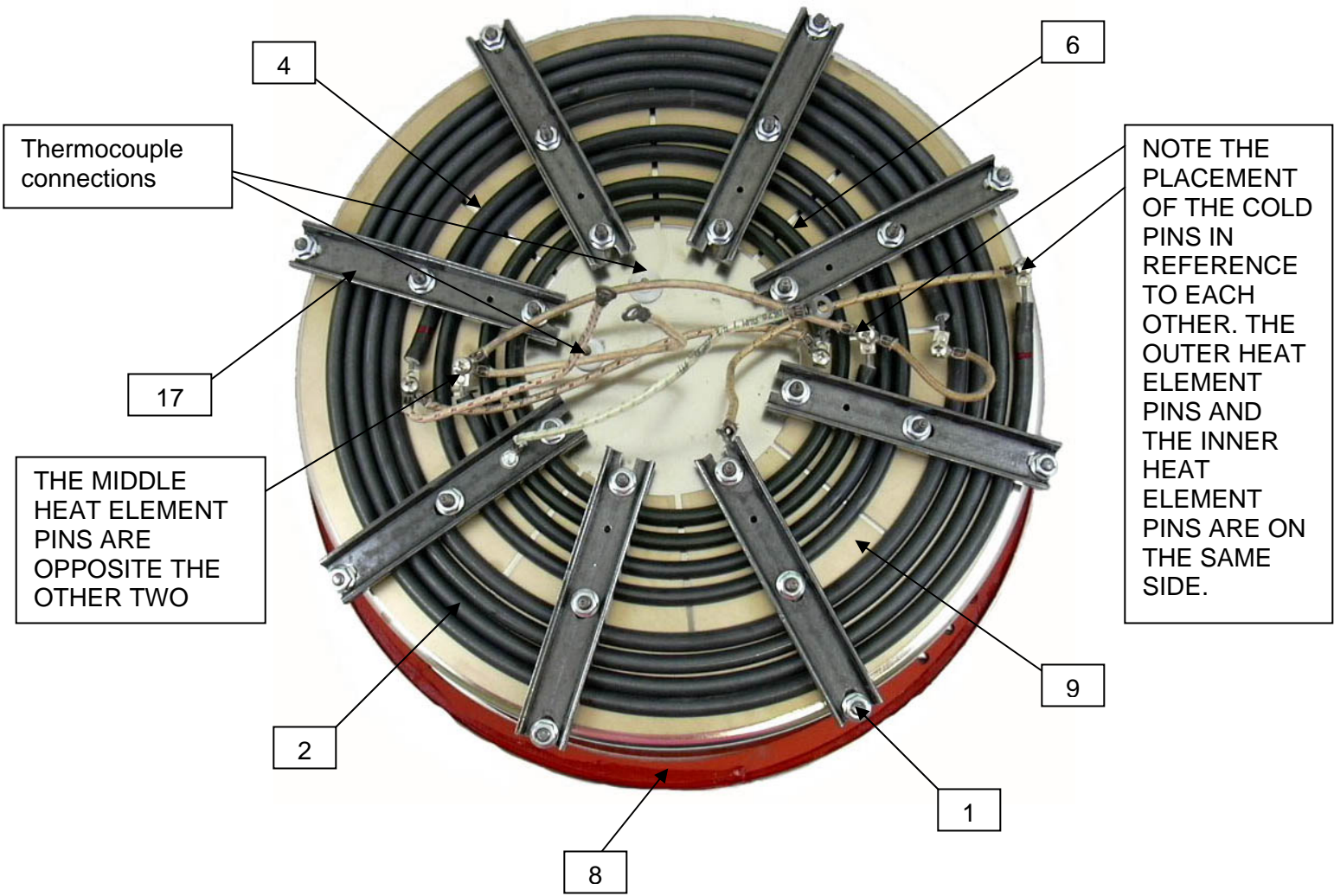

KETTLE LIST

Item No	Part No	Description
1	41139	DUMP HANDLE PLASTIC
2	47976	CROSSBAR FASTNER, NO PINS
3	47977	CROSSBAR FASTNER, W/PINS
4	48961	LID, AGITATOR ASSY
5	12611	5/16-18 LH AGITATOR SCREW
6	41380	SPUR GEAR
7	41400	NEEDLE BEARING TORINGTO
8	41730	WOODRUFF KEY #3 1/8X1/2
9	41742	SET SCREW #10-32 X 3/16
10	41814	5/16-18 X 1/2 BUTTON HEAD
11	47325	SET COLLAR 5/8ID X 1-1/4OD
12	48965	CROSSBAR ASSEMBLY
13	47154	WARNING, DO NOT IMMERSE
14	47689	OIL TUBE W / FUNNEL
15	48974	52OZ CROSSBAR W/BUSHING
16	48969	AGITATOR WELD ASSY 52OZ
17	62779	FRONT KETTLE LID
18	62780	REAR KETTLE LID
19	48966	RH KETTLE BOTTOM ASSY
	48966P	PASS THRU KETTLE
20	40963	JUNCTION BOX GASKET
21	40965	JUNCTION BOX GASKET
22	41129	TERMINAL BLOCK KETTLE
23	41296	KETTLE JUNCTION BOX COVER
24	41748	KETTLE LEAD WIRE,RED
25	47999	THREADED BLOCK
26	48957	52OZ KETTLE WELD ASSY
27	48959	KETTLE SHELL WELD
	48959P	PASS THRU SHELL WELD
28	48984	KETTLE LEAD ASSY
29	61084	JUNCTION BOX ASSEMBLY

KETTLE LIST CONTINUED

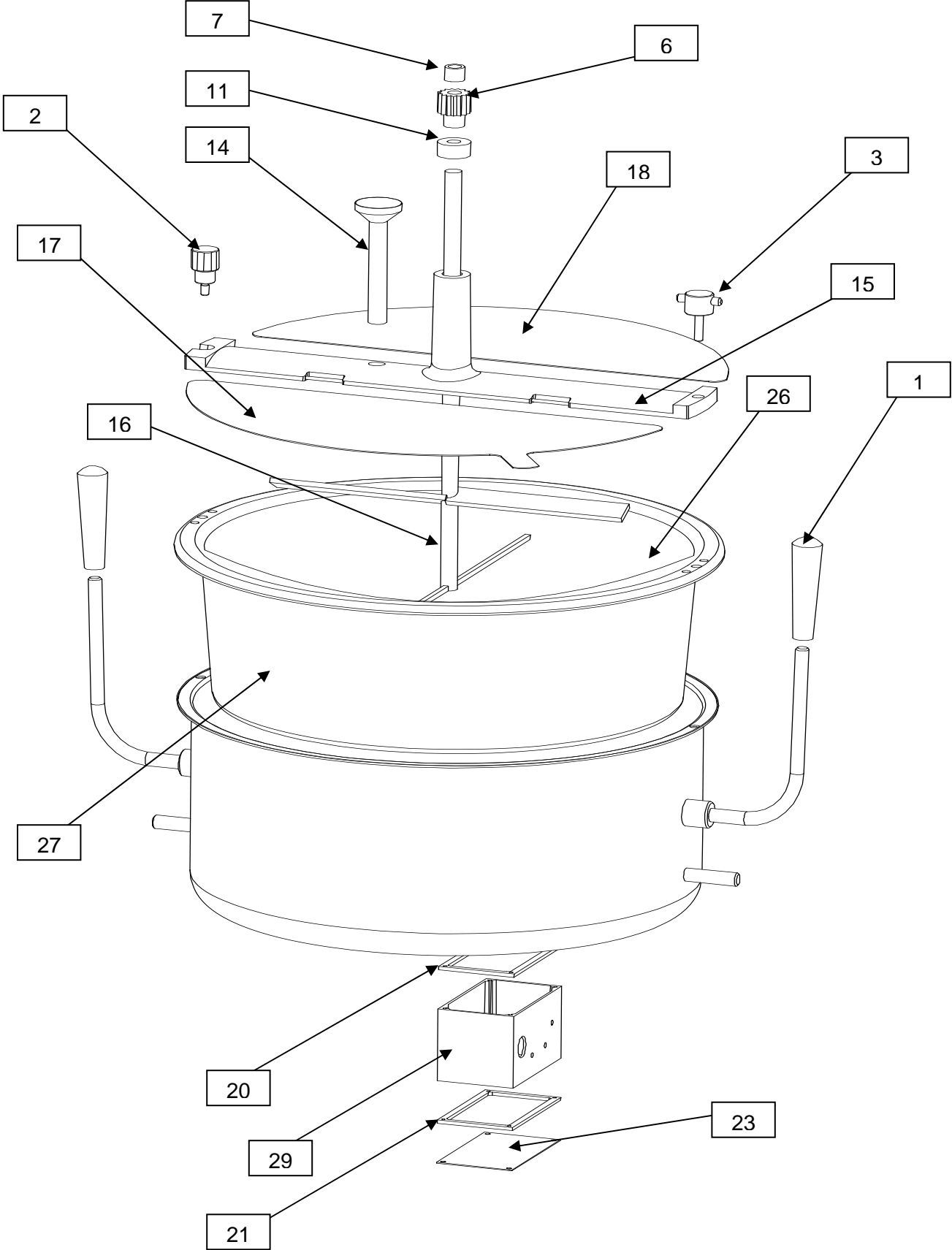

ELECTRICAL LIST

Part No	Description
39410	3 POSITION ROCKER SWITCH (FLEXI-POP)
41001	TEMPERATURE CONTROL
62728	EXHAUST BLOWER, 115V
41965	EXHAUST BLOWER, 220V (EXPORT)
41031	SWITCH OIL PUMP
41449	KETTLE DRIVE MOTOR, 115V
41500	KETTLE DRIVE MOTOR, 230V (EXPORT)
41499	WIRE HARNESS,OIL PUMP
41640	FOIL ELEMENT, 8 WATT 120V
41640EX	FOIL ELEMENT, 8 WATT 230V (EXPORT)
41712	MOLDED RECEPTACLE, WARMER
41735	STRAIN RELIEF SR 31-2
41979	175W HEAT LAMP 120V
47138	250W HEAT LAMP 220-230V (EXPORT)
42743	HOLE PLUG, ROCKER SWITCH
42798	SWITCH, LIGHTED ROCKER GR
44073	STRAIN RELIEF #SR-6P-4
45396	BUSHING-SNAP #SB-875-10
46081	RELAY, POWER, 120V, DPDT
46456	1.25 DIA NYLON HOLE PLUG
47199	BLOWER PLUG & CORD
47208	TERMINAL BLOCK,8 TERMINAL
47282	BUSHING, HEYCO SNAP
47364	CIRCUIT BREAKER 15 AMP
48659	CIRCUIT BREAKER 10 AMP 277V (EXPORT)
48018	EXHAUST BLOWER 120V,60CY
48037	EXHAUST BLOWER 220V,50CY (EXPORT)
48301	CAPACITOR STRAP
48541	BRACKET, HEAT CONTROL
55039	PILOT LIGHT, 125V AMBER
55039EX	PILOT LIGHT, 230V AMBER (EXPORT)
48714	SURGE PROTECTOR 125V
48714EX	SURGE PROTECTOR 230V
55051-36	K THERMOCOUPLE EXTENSION
48604	35MM DIN RAIL 6 INCHES (PASS THRU)
48645	RELAY 120 VAC DPDT (PASSTHRU)
48660	PILOT LIGHT, 125V GREEN
48660EX	PILOT LIGHT, 250V GREEN (EXPORT)
48673	HEAT SINK (FLEXI-POP)
48675	PHASE CONTROL 120VAC 25A (FLEXI-POP)
48710	TRANSFORMER, 120-12 VAC (FLEXI-POP)

ELECTRICAL LIST CONTINUED

Item No	Part No	Description
39		
40	48922	INDICATOR LIGHT DUAL (PASS THRU, FLEXI-POP)
41	48912	CONTACTOR IEC 50A 120V (FIRE SUPPRESSION)
42		
43		
44	82260	POWER CORD ASSY
45		
46	82920	RECEPTACLE 50AMP
47	82922	RECEPTACLE COVER 50AMP
48	89017	STRAIN RELIEF T&B #3303
49	89087	240 VAC TRANSIENT FILTER
50	47385	THERMOSTAT WARMER
51	47548	MOUNTING ANGLE
52	61123	BLOWER, 120V
	61124	BLOWER, 230V (EXPORT)
53	61128	HEAT ELEMENT 120V,800W
	61135	HEAT ELEMENT 230V,800W (EXPORT)
54	61133	HEATER CLAMP
55	61134	HEATER MOUNT
56	62093	WARMER PLATE
57	76026	STRAIN RELIEF #SR-6P3-4

ACCESSORIES LIST

Item No	Part No	Description
1	48904	52OZ ACCESSORY PACK ASSY
2	2072	PERF JET SCOOP REGULAR RH
3	41162	OIL TUBE PLASTIC 2 FT LG
4	41752	FLAVACOL CONT WELDMENT
5	47380	TUBE BRUSH
6	47681	MEASURE 30CC
7	48905	52OZ WGT MEA.CUP GREEN

FLEXI-POP MODELS

8	41720	32OZ ACCESSORY PACK ASSY
9	2072	PERF JET SCOOP REGULAR RH
10	41162	OIL TUBE PLASTIC 2 FT LG
11	41752	FLAVACOL CONT WELDMENT
12	47380	TUBE BRUSH
13	47681	MEASURE 30CC
14	41540	32OZ WGT MEA.CUP BLUE

DOME LIST

STANDARD DOME

Item No	Part No	Description
1	12502	FLUORESCENT TUBE LOCK
2	41020	LIGHT TUBE HOLDER
3	41021	LIGHT TUBE HLDR STARTER
4	75026	STARTER FS-4
5	82003	FLUOR LIGHT TUBE 30WATT
6	82109	LIGHT BALLAST 30 WATT
7	82414	LIGHT BALLAST 240V 50HZ (EXPORT)
8	82473	SIGN, LIGHTED DOME

NEON DOME

Item No	Part No	Description
1	47562	WIRE HARNESS WARMER
2	49133	DEAD END SPLICE TRANSLU
3	67432	NEON SIGN ASSY, 30 INCH
4	67433	TRANSFORMER MTG. BRKT.
5	67445	TRANSFORMER, 6.5 KV, 20MA
6	67488	BOTTOM NEON SIGN BRACKET
7	82962	GTO COVERING, NEON SIGN
8	67509	TRANSFORMER, STEP DOWN (EXPORT)
9		
10		
11		

Wiring Diagram - 52 Oz.

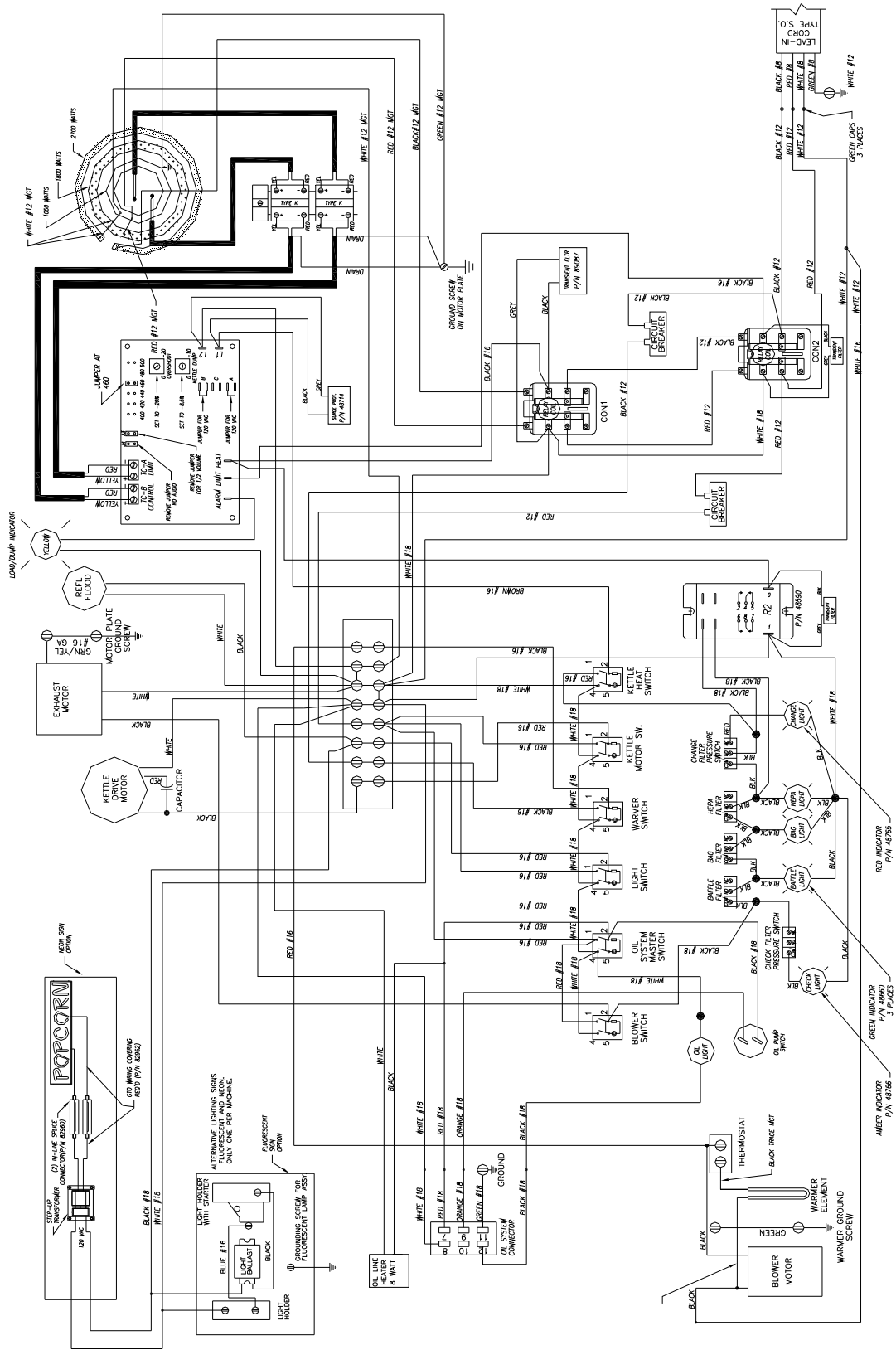

Wiring Diagram - 52 Oz. Fire Suppression

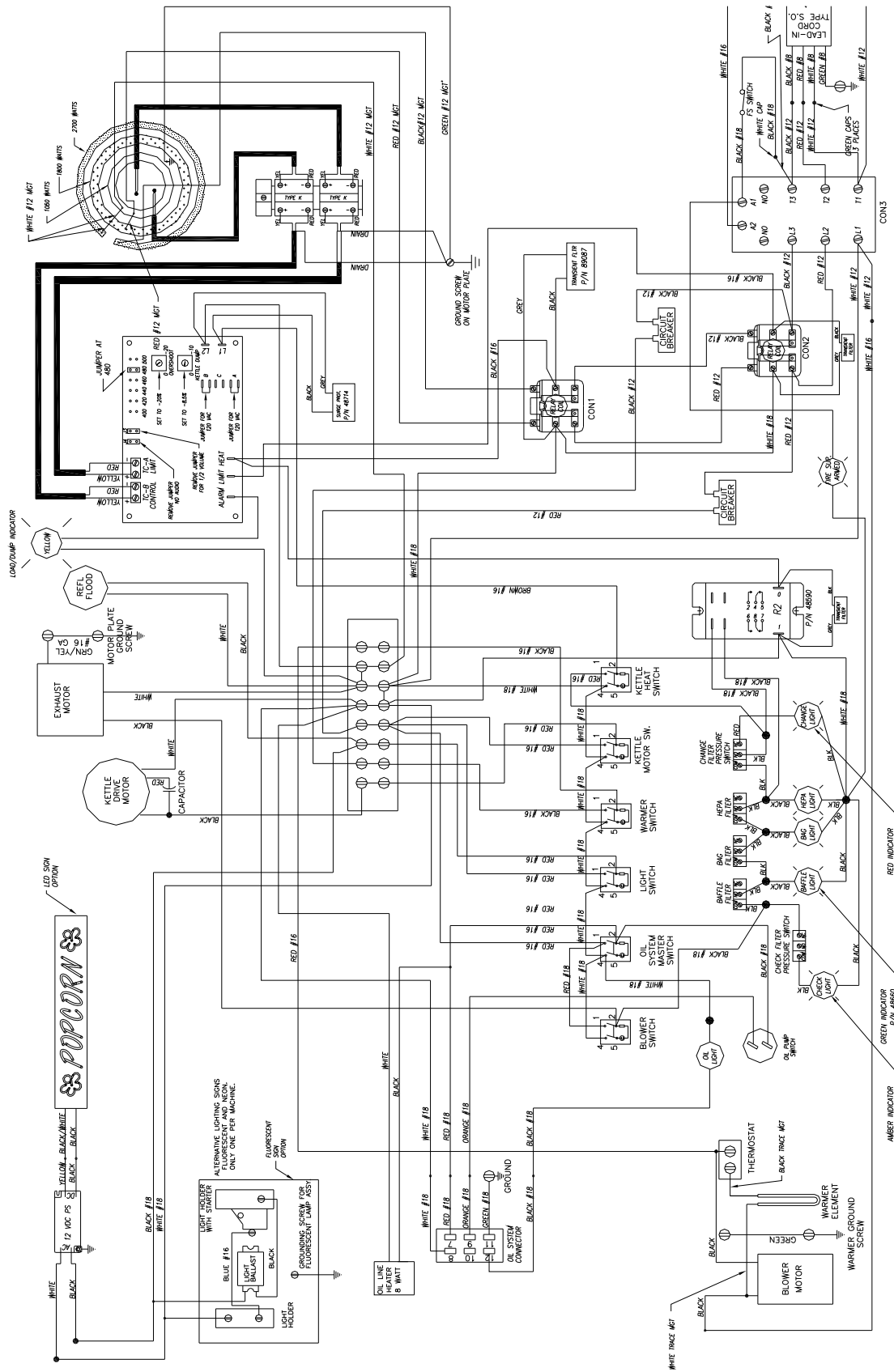

WARRANTY

WE WARRANT to the original purchaser the Gold Medal equipment sold by us to be free from defects in material or workmanship under normal use and service. Our obligation under this warranty shall be limited to the repair or replacement of any defective part for a period of six (6) months from the date of sale to the Original Purchaser with regard to labor and two (2) years with regard to parts and does not cover damage to the equipment caused by accident, alteration, improper use, voltage, abuse, or failure to follow instructions.

THIS WARRANTY IS IN LIEU OF ALL OTHER WARRANTIES EXPRESSED OR IMPLIED, AND OF ALL OTHER OBLIGATIONS OR LIABILITIES ON OUR PART, INCLUDING THE IMPLIED WARRANTY OF MERCHANTABILITY. THERE ARE NO WARRANTIES WHICH EXTEND BEYOND THE DESCRIPTION ON THE FACE HEREOF. We neither assume, nor authorize any other person to assume for us, any other obligation or liability in connection with the sale of said GOLD MEDAL equipment or any part thereof.

The term "Original Purchaser" as used in this warranty shall be deemed to mean that person, firm, association, or corporation who was billed by the GOLD MEDAL PRODUCTS COMPANY, or their authorized distributor for the equipment.

THIS WARRANTY HAS NO EFFECT AND IS VOID UNLESS THE ORIGINAL PURCHASER FIRST CALLS GOLD MEDAL PRODUCTS COMPANY AT 1-800-543-0862 TO DISCUSS WITH OUR SERVICE REPRESENTATIVE THE EQUIPMENT PROBLEM, AND, IF NECESSARY, FOR INSTRUCTIONS CONCERNING THE REPAIR OR REPLACEMENT OF PARTS.

NOTE: This equipment is manufactured and sold for commercial use only.



GOLD MEDAL PRODUCTS COMPANY

10700 Medallion Drive

Cincinnati, Ohio 45241-4807 USA

www.gmpopcorn.com

Phone: 1-800-543-0862

Fax: 1-800-542-1496

© The text, descriptions, graphics and other material in this publication are the proprietary and exclusive property of Gold Medal Products Company and shall not be used, copied, reproduced, reprinted or published in any fashion, including website display, without its express written consent.