

Couplings | Thomas® Flexible Disc Couplings
(English-Inch)



TABLE OF CONTENTS

| <u>DESCRIPTION</u> | <u>PAGE</u> | |
|---|-------------|------------|
| The Thomas Advantage | 3 | |
| Application Guide | 4, 5 | |
| Misalignment | 6 | |
| Selection Procedures | 7 | |
| Service Factors | 8 | |
| Selection Examples | 9 | |
| <u>ORDERING INSTRUCTIONS AND INFORMATION</u> | | |
| Ordering Instructions | 10 | |
| Tapered Bore Information | 10 | |
| Bore Specifications | 11 | |
| Taper Lock Bushings | 11 | |
| Q.D. Bushings | 11 | |
| Alignment Instructions | 12 | |
| Locknut Tightening Torques | 12 | |
| Application Data Form | 13, 14 | |
| <u>CLOSE COUPLED COUPLINGS</u> | | |
| Series 54RDG | 15 | |
| DBZ-A, DBZ-B | 16 | |
| <u>SPACER COUPLINGS</u> | | |
| DBZ-C | 20 | |
| Series 52 | 17 | |
| Series 71 | 18, 19 | |
| <u>CAST IRON COUPLINGS</u> | | |
| AMR | 21 | |
| CMR | 22, 23 | |
| BMR | 24 | |
| <u>FLOATING SHAFT COUPLINGS</u> | | |
| Floating Shaft Coupling Types | 26 | |
| SN, SF, SV | 26, 27 | |
| SN-GA | 25 | |
| SN Adjustable | 39 | |
| <u>SINGLE FLEXING DISC COUPLINGS</u> | | |
| BMR Single | 29 | |
| ST | 28 | |
| SN Single | 30 | |
| <u>HIGH PERFORMANCE COUPLINGS</u> | | |
| Series 63 | 32, 33 | |
| THP | 31 | |
| <u>MINIATURE COUPLINGS</u> | | |
| CC, CA | 34 | |
| CB, CBC | 35 | |
| CE | 36 | |
| <u>SPECIAL FLEXIBLE DISC COUPLINGS</u> | | 37, 38, 39 |

THE THOMAS® ADVANTAGE

M.T. Thomas revolutionized the coupling industry by inventing the flexible disc coupling in 1919. Today Thomas' engineers continue to improve the disc coupling through design innovation, modern materials and lean manufacturing processes. The Rex® Thomas® disc coupling is manufactured within a certified ISO 9001 quality system and is unsurpassed in its reputation for quality, reliability and easy maintenance features. The flexible disc packs are engineered for infinite life when applied within the published ratings and environmental guidelines. Our experience and dedication to conservative design standards assures maximum reliability on the most critical drive systems.

DISC COUPLING BENEFITS

- No lubrication
- Visual inspection
- No backlash
- Low restoring forces
- Wide temperature range

REX® THOMAS® BENEFITS

- High reliability
- Broad range of styles and sizes
- Extensive engineering support
- Custom design capability
- Global support

Tpack™ DISC PACK

Rex Thomas disc couplings are known for high reliability. The Tpack™ advanced technology flexible disc element makes maintenance easy and provides additional torque density. This high quality design functions with our current products and already installed Thomas disc couplings, performing in a variety of applications worldwide.



Unitized pack for easy assembly and maintenance, alternating single headed bushings to provide full fastener bearing area and retrofitability into Series 52, AMR, CMR, and SN style coupling sizes 225-750.

OTHER NEW ITEMS IN THIS CATALOGUE

Series 54RDG increased torque density and speed potential for close coupled applications.

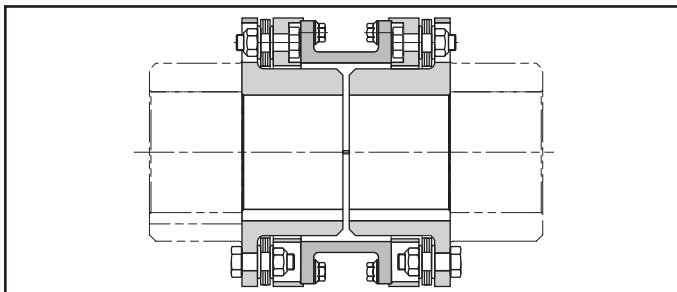

Series 71 eight bolt design uses our popular Series 71 design with drop out center section assembly and Tpack™ disc pack, we are able to provide significant increases in torque capacity allowing for a smaller coupling selection and high speed potential.

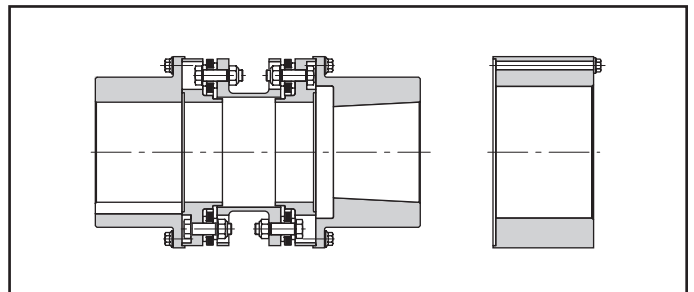

* Tpack not available for size 450 SN

**Tpack used in Series 71 not interchangeable with Series 52, AMR, CMR or SN.

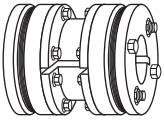
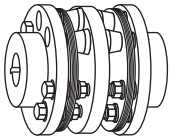
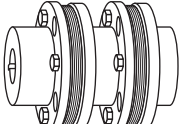
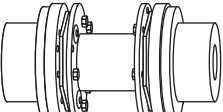
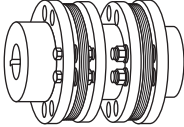
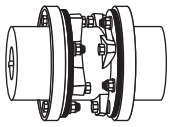
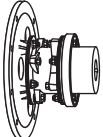
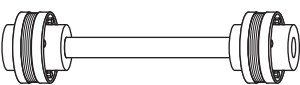
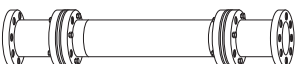

Note: Dimensions subject to change. Certified dimensions of ordered material furnished on request.

THOMAS® COUPLING APPLICATION GUIDE

| Coupling Type | Typical Applications | Torque Range* (lb.-in.) | RPM* Range | Max.* Bore (in.) | Page Number | Max. Ang. Misalignment Per Disc Pack |
|---|--|-------------------------|--------------|------------------|-------------|--------------------------------------|
|  <p>Series 54RDG</p> | Close-coupled applications. Suitable as replacement for gear and grid couplings | Up to 1,724,800 | Up to 10,500 | 9.00 | 15 | 1/3° |
|  <p>DBZ-B</p> | Mixers, Compressors, Agitators, Blowers and Fans, Centrifugal Pumps, Conveyors | Up to 43,400 | Up to 9,000 | 4.75 | 16 | 1/2° |
|  <p>Series 52</p> | Pumps & Compressors (Centrifugal, Rotary, Lobe, and Axial), Speed Increaseers, Fans, Dynamometers | Up to 3,390,000 | Up to 15,000 | 14 | 17 | 1/3° |
|  <p>Series 71</p> | Pumps & Compressors with popular Shaft Separation Standards. Blowers, Fans, Speed Increaseers | Up to 1,677,600 | Up to 20,800 | 10.8 | 18, 19 | 1/2° – 1/3° |
|  <p>DBZ-C</p> | Process Pumps with ANSI, API, and other shaft separation standards. Blowers, Fans, Mixers, Compressors, Conveyors | Up to 50,000 | Up to 9,500 | 4.75 | 20 | 1/2° |
|  <p>AMR</p> | Reciprocating Pumps and Compressors, Fan Drives, Blowers, Heavy-duty Industrial Drives, Crushers, Extruders, Hoists, Dredges, Generators, Chippers, Calender, Mill Drives, Conveyors | Up to 2,840,000 | Up to 2,500 | 15.5 | 21 | 1/3° |
|  <p>CMR</p> | Engine Drivers, Reciprocating Pumps and Reciprocating Compressors, Heavy-duty industrial drives – where flywheel mounting is required | Up to 2,840,000 | Up to 2,500 | 15.5 | 22, 23 | 1/3° |
|  <p>BMR</p> | Blowers, Fans, Crushers, Marine Drives, Dredge Pumps, Hoists, Heavy-duty Industrial Drives. Reciprocating Pumps and Compressors, Paper Mill Drives, Conveyors | Up to 261,000 | Up to 1,800 | 6 | 24 | 1/3° |
|  <p>SN-GA</p> | Pulp and Paper machines, Line Shafts, Pelletizers, Crushers and Mill Drives. Replacing long span gear couplings, bolting to existing rigid hubs | Up to 1,107,000 | Up to 1,800 | N/A | 25 | 1/3° |

* These ratings are for cataloged coupling sizes. For special requirements, consult Rexnord Industries, Inc.

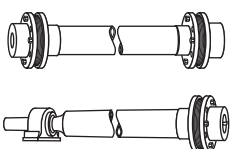
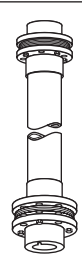
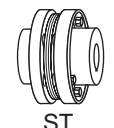
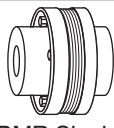
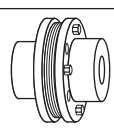
THOMAS® COUPLING APPLICATION GUIDE

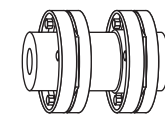
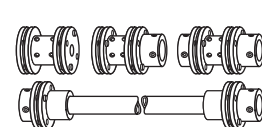
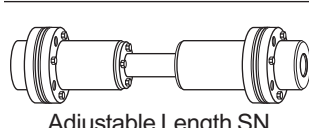
| Coupling Type | Typical Applications | Torque Range* (lb.-in.) | RPM* Range | Max.* Bore (in.) | Page Number | Max. Ang. Misalignment Per Disc Pack |
|---|--|----------------------------|---------------------|------------------------|----------------|--|
|  <p>SN SF</p> | Turbines, Pumps, Compressors, Test Stands, Generators, Speed Increaseers, Fans (Cooling Tower, Mine Ventilating, Forced and Induced Draft), Paper Mill Drives, Line Shafts, Printing Machines, Pumps. Available as a standard in corrosion-resistant materials | Up to 1,466,000 | Up to 3,600 | 10.12 | 26, 27 | 1/3° |
|  <p>SV</p> | Vertical Drives such as Sewage Pumps, Printing Machines, Marine Pumps. Available as a standard in corrosion-resistant materials | Up to 1,466,000 | Up to 3,600 | 10.12 | 26, 27 | 1/3° |
|  <p>ST</p> | Accommodates angular misalignment only. Three-bearing applications where radial load is supported by the coupling, such as single-bearing generators, V-belt sheaves, etc. | Up to 200,000 | Up to 2,500 | 8 | 28 | 1/3° |
|  <p>BMR Single</p> | Accommodates angular misalignment only. May be used with solid intermediate shafts for applications listed for BMR. Not intended as a radial-load-supporting coupling | Up to 1,040,000 | Up to 2,500 | 9.25 | 29 | 1/3° |
|  <p>SN Single</p> | Accommodates angular misalignment only. May be used with intermediate solid shaft for applications similar to BMR, but with high speed capacity. Available in corrosion-resistant materials | Up to 838,800 | Up to 7,100 | 8 | 30 | 1/3° |
|  <p>THP</p> | Turbines, Pumps, Compressors, Speed Increaseers, Test Stands | Up to 579,000 | Up to 28,500 | 5 | 31 | 1/4°, 1/3° |
|  <p>Series 63</p> | Turbines, Pumps, Compressors, Test Stands, Generators, Speed Increaseers | Up to 1,150,000 | Up to 36,000 | 8.84 | 32, 33 | 1/4° |
|  <p>Miniature Couplings</p> | Tachometers, Encoders, Switches, Ball Screws, Test Stands, Pumps, Compressors, Centrifuges, Theodolites, Sonar, Radar, Scales, Carburetors | Up to 700 | Up to 150,000 | 1.25 | 34 - 36 | 1/2° - 2° |
|  <p>Adjustable Length SN</p> | Same applications as SN but where axial and/or angular adjustment is desired. Many sizes in stock for emergency break down replacement | Up to 22,200 | Up to 1,800 | 3.12 | 39 | 1/3° |

* These ratings are for cataloged coupling sizes. For special requirements, consult Rexnord Industries, Inc.

Note: Dimensions subject to change. Certified dimensions of ordered material furnished on request.

THOMAS® FLEXIBLE COUPLINGS

A flexible coupling is a device used to connect the ends of two shafts, transmit torque, and at the same time, accommodate slight misalignments which develop in service.

The primary functions of all flexible couplings are:

1. To transmit power from one shaft to another, efficiently and effectively.
2. To accommodate slight shaft misalignments which develop in service.

The secondary functions of flexible couplings are:

1. Protect connected equipment.
 - a. Absorb shock, vibration and pulsations.
 - b. Decrease cross load on bearings.
 - c. Accept load reversals.
 - d. Minimize backlash.
2. Minimize "installation" and "maintenance" difficulties.

Shafts become misaligned during operation because of settling foundations, the effects of heat, vibration, etc. These misalignments take place in the form of angular misalignment, parallel misalignment, or axial movement of the shafts. Therefore, to get full service life from any flexible coupling, it is necessary to:

1. **ASSURE PROPER SHAFT ALIGNMENT DURING INITIAL INSTALLATION.**
2. **OCCASIONALLY CHECK FOR AND CORRECT SHAFT MISALIGNMENTS DURING OPERATION.**

CAUTION

All rotating power transmission products are potentially dangerous and must be properly guarded.
Never operate coupling without an OSHA approved guard.

What is Misalignment?

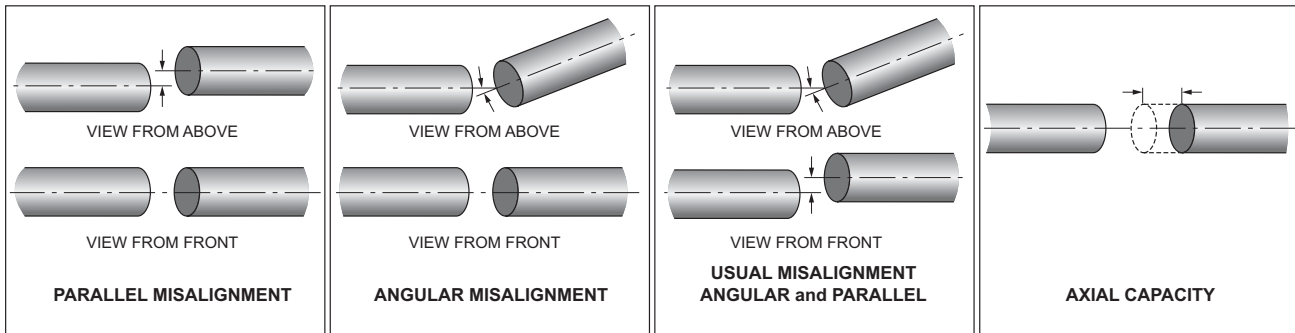

Misaligned shafts not properly coupled are subject to severe stresses which damage bearings and seals. Any or all of the misalignments shown in the above diagrams are present in all connected drives. Therefore, it is imperative that flexible couplings be used to avoid costly damage to your equipment.

Initial alignment of machinery is one of the most critical factors affecting coupling performance and reliability. Each particular style of coupling has its own misalignment capabilities. The installation and alignment instructions outline the initial alignment requirements. These initial values are approximately one-third of the total coupling misalignment capacity. This means that the coupling has ample reserve to compensate for operational misalignments which develop as a result of bearing wear, foundation settling, thermal growth, pipe strain, etc. However, the closer the initial alignment, the more reserve margin a coupling has to compensate for misalignments during the life of the machine. A

coupling that operates with large amounts of misalignment will have a limited life, while a coupling operating within capacity will have infinite life.

The customer and coupling manufacturer must mutually select the correct size and type coupling for the application. Good service life will then become a reality if proper installation and alignment procedures are followed.





The following pages show basic coupling arrangements and load classifications based on years of experience in coupling applications in all phases of power transmission. Any unusual operating or misalignment conditions should be referred to Rexnord to assure proper selection of size and type of coupling.

THOMAS® COUPLING SELECTION

SELECTION PROCEDURES

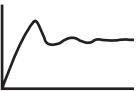
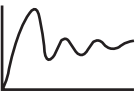
SERVICE FACTORS

Service Factors are a means of classifying different equipment and applications into various load classifications. Due to variations in application of equipment, service factors are used to adjust equipment ratings to accommodate for variable loading conditions.

| | Load Classifications | Service Factors |
|---|--|---|
|  | Continuous service and running loads vary only slightly. | 1.0 |
|  | Torque loading varies during operation of the equipment. | 1.5 |
|  | Torque loading varies during operation, frequent stop/start cycles are encountered. | 2.0 |
|  | For shock loading and substantial torque variations. | 2.5 |
|  | For heavy shock loading or light reversing drives. | 3.0 |
|  | Reversing torque loads do not necessarily mean reversal of rotation. Depending upon severity of torque reversal, such loads must be classified between "medium" and "extreme." | Consult Rexnord Industries, Inc. |

Close Coupled Couplings and Spacer Couplings

The need for flexible couplings in high speed applications continues to grow. Thomas couplings have been particularly successful in these applications due to their desirable qualities of being in balance and staying in balance.

Thomas couplings are manufactured with an inherent high level of balance quality "designed in" to the product. That is, components are manufactured to close tolerances and concentricities, and fits between mating parts are carefully controlled.

The balance requirements of a flexible coupling are in reality governed by the characteristics and requirements of the connected equipment; in other words, the dynamics of the system dictate the required coupling balance quality. Different systems operating at the same horsepower and speed may vary in their balance requirements, depending on the "sensitivity" of the system to coupling unbalance. Some of the factors affecting sensitivity are:

- Stiffness of bearing supports
- Distance between bearing supports
- Shaft overhang between bearing and coupling
- Shaft diameter relative to coupling weight

The American Gear Manufacturers Association (AGMA) has developed Standard 9000-C90, entitled "Balancing Classification for

DISC COUPLING SELECTION PROCEDURE

The following procedure can be used to select Disc couplings for most applications. For applications involving other than normal loading or design, special consideration must be given to coupling selection. Rexnord application engineers are readily available for selection, advice and assistance.

1. Determine HP/100RPM:

$$\text{HP/100 RPM} = \frac{\text{Horsepower} \times 100}{\text{RPM}}$$

2. Determine Service Factor:

Select the proper Service Factor from Table. Note, if not listed, see Load Classification Table.

Note: The Service Factor Table considers the driven equipment only and assumes a normal electric motor or turbine driver. For prime movers of the reciprocating type (engines, etc.) add the following to the Service Factor:

For 8 or more cylinders, add 0.5

For 6 cylinders, add 1.0

For 4 cylinders, add 1.5

For less than 4 cylinders, consult Rexnord Industries, Inc.

3. Select the Coupling:

Turn to the page describing the selected coupling type and select the smallest coupling capable of transmitting the calculated HP/100 RPM at the proper Service Factor.

4. Check Limiting Conditions:

a. Check maximum speed (dynamic balancing may be required – see page 26)

b. Check maximum bore.

c. Check other dimensions such as shaft separation, overall length, O.D., etc.

d. Check to be sure that the maximum torque to be transmitted, such as start-up or stall torques, do not exceed the coupling's Peak Overload Torque Rating.

Note: Variable frequency and synchronous motors and certain induction motors produce transient torques several times the continuous rating of the unit. Consult motor manufacturer.

5. Refer to page 10-11 for Ordering Information.

Flexible Couplings which attempt to relate the above factors, and to also define coupling balance quality as related to the system factors.

Rexnord has developed recommendations for coupling balancing based on AGMA 9000-C90 and the inherent balance level of the various couplings shown in this catalog. These are shown on the data sheets as follows:

- "Max RPM Not Balanced". This is the maximum operating speed where the coupling will operate under normal conditions, and not create unacceptable vibration due to coupling unbalance. This is based on many years of operating experience on a wide variety of drive systems.
- "Max. RPM Balanced". This is the maximum operating speed where the coupling, after balancing, will still be compatible with the typical drive system. Consult Rexnord Industries, Inc. for speed requirements in excess of this value; special designs or manufacturing procedures may be required.

Certain coupling types are not suitable for dynamic balancing, and should not be used if balancing is required. These types are:

Type AMR Type CMR
Type BMR Type ST

Series 63 and THP couplings are always furnished dynamically balanced in accordance with the requirements of the application.

Note: A coupling is a critical component of any drive system. The basic coupling selection criteria is used to determine the size and style only. It is recommended that the system be analyzed for torsional and lateral stability using the specific coupling mass elastic data. The coupling weight, inertia, lateral stiffness, and torsional stiffness are available for this system analysis. It is the responsibility of the coupling user to assure the system, with the coupling as a component, properly functions.

THOMAS® COUPLING SELECTION

TYPICAL SERVICE FACTORS – MOTOR AND TURBINE DRIVEN EQUIPMENT*

| Application | Typical Service Factor | Application | Typical Service Factor | Application | Typical Service Factor |
|---|-------------------------------------|---|------------------------|--|------------------------|
| AGITATORS | | GENERATORS | | Presses | 2.0 |
| Pure Liquids | 1.0 | Non-Welding | 1.5 | Reel | 1.5 |
| Variable Density | 1.5 | Welding | 3.0 | Stock Chests | 1.5 |
| ALTERNATOR | 1.5 | HAMMER MILLS | 3.0 | Suction Roll | 2.0 |
| BLOWERS | | LUMBER INDUSTRY | | Washers and Thickeners | 1.5 |
| Centrifugal | 1.0 | Barkers - Drum Type | 2.5 | Winders | 1.5 |
| Lobe | 1.5 | Edger Feed | 2.0 | PRINTING PRESSES | 1.5 |
| Vane | 1.5 | Live Rolls | 2.0 | PULLERS | |
| BRIQUETTER MACHINES | 2.0 | Log Haul - Incline | 2.0 | Barge Haul | 2.0 |
| CAN FILLING MACHINES | 1.0 | Log Haul - Well Type | 2.0 | PUMPS | |
| CANE KNIVES | 2.0 | Off Bearing Rolls | 2.0 | Centrifugal | |
| CAR DUMPERS | 2.5 | Planer Feed Chains | 2.0 | General Duty (Liquid) | 1.0 |
| CAR PULLERS | 1.5 | Planer Floor Chains | 2.0 | Boiler Feed | 1.5 |
| CLAY WORKING MACHINERY | 2.0 | Planer Tilting Hoist | 2.0 | Slurry (Sewage, etc.) | 1.5 |
| COMPRESSORS | | Slab Conveyor | 1.5 | Dredge | 2.0 |
| Centrifugal | 1.0 | Sorting Table | 1.5 | Reciprocating | |
| Lobe, Vane, Screw | 1.5 | Trimmer Feed | 2.0 | Double Acting | 2.0 |
| Reciprocating - Multi-Cylinder | Consult Rexnord Industries, Inc. | MACHINE TOOLS | | Single Acting | |
| Axial | 1.0 | Bending Roll | 2.0 | 1 or 2 Cylinders | 2.5 |
| CONVEYORS - uniformly loaded or fed | 1.5 | Plate Planer | 1.5 | 3 or more Cylinders | 2.0 |
| CONVEYORS - heavy duty - not | | Punch Press - Gear Driven | 2.0 | Rotary - Gear, Lobe, Vane | 1.5 |
| uniformly fed | 2.5 | Tapping Machines | 2.5 | RUBBER INDUSTRY | |
| CRANES AND HOISTS | 2.0 | Other Machine Tools | | Mixer - Banbury | 3.0 |
| CRUSHERS | 3.0 | Main Drives | 1.5 | Rubber Calendar | 2.0 |
| DREDGES | | Auxiliary Drives | 1.5 | Rubber Mill (2 or more) | 2.5 |
| Cable Reels | 2.0 | METAL MILLS | | Sheeter | 2.0 |
| Conveyors | 1.5 | Draw Bench - Carriage | 2.5 | Tire Building Machines | 2.5 |
| Cutter Head Drives | 2.5 | Draw Bench - Main Drive | 2.5 | Tire & Tube Press Openers | 1.0 |
| Jig Drives | 2.5 | Forming Machines | 2.5 | Tubers and Strainers | 2.0 |
| Maneuvering Winches | 2.0 | Slitters | 2.0 | SCREENS | |
| Pumps | 2.0 | Table Conveyors | | Air Washing | 1.0 |
| Screen Drives | 2.0 | Non-Reversing | 2.5 | Rotary - Stone or Gravel | 1.5 |
| Stackers | 2.0 | Reversing | 3.0 | Traveling Water Intake | 1.5 |
| Utility Winches | 1.5 | Wire Drawing & Flattening Machine | 2.0 | Vibratory | 2.5 |
| ELEVATORS | | Wire Winding Machine | 2.0 | SEWAGE DISPOSAL EQUIPMENT | 1.5 |
| Bucket | 2.0 | MILLS, ROTARY TYPE | | SEWAGE TREATMENT PUMPS | 1.5 |
| Centrifugal Discharge | 1.5 | Ball | 2.5 | TEXTILE INDUSTRY | |
| Escalators | 1.5 | Cement Kilns | 2.0 | Batchers | 1.5 |
| Freight | 2.0 | Dryers & Coolers | 2.0 | Calenders | 2.0 |
| Gravity Discharge | 1.5 | Kilns | 2.0 | Card Machines | 1.5 |
| EXTRUDERS | | Pebble | 2.0 | Cloth Finishing Machines | |
| Plastic | 2.0 | Rod | 2.0 | (washers, pads, tenters) | |
| Metal | 2.5 | Tumbling Barrels | 2.0 | (dryers, calenders, etc.) | 1.5 |
| FANS | | MIXERS | | Dry Cans | 2.0 |
| Centrifugal | | Concrete Mixers | 2.0 | Dryers | 1.5 |
| Forced Draft (Hostile Environment) | 1.5 | Drum Type | 2.0 | Dyeing Machinery | 1.5 |
| Induced Draft (Hostile Environment) | 1.5 | OIL INDUSTRY | | Looms | 1.5 |
| Axial | | Chillers | 1.5 | Mangles | 1.5 |
| Forced Draft (Hostile Environment) | 1.5 | Oil Well Pumping | 2.0 | Nappers | 1.5 |
| Induced Draft (Hostile Environment) | 1.5 | Paraffin Filter Press | 2.0 | Soapers | 1.5 |
| Mine Ventilation | 2.5 | Rotary Kilns | 2.0 | Spinners | 1.5 |
| Cooling Towers | 1.5 | PAPER MILLS | | Tenter Frames | 1.5 |
| Light Duty Blower & Fans | 1.0 | Barker Auxiliaries, Hydraulic | 2.5 | Winders (Other than Batchers) | 1.5 |
| FEEDERS | | Barker, Mechanical | 2.5 | WINDLASS | 2.0 |
| Light Duty | 1.5 | Barking Drum (Spur Gear Only) | 2.5 | WOODWORKING MACHINERY | 1.5 |
| Heavy Duty | 2.5 | Beater & Pulper | 2.0 | | |
| FOOD INDUSTRY | | Bleacher | 1.0 | | |
| Beet Slicer | 2.0 | Calenders | 2.0 | | |
| Cereal Cooker | 1.5 | Converting Machines, except | | | |
| Dough Mixer | 2.0 | Cutters, Platers | 1.5 | | |
| Meat Grinders | 2.0 | Couch | 2.0 | | |
| Can Filling Machine | 1.0 | Cutters, Platers | 2.0 | | |
| Bottling | 1.5 | Cylinders | 2.0 | | |
| | | Dryers | 2.0 | | |
| | | Felt Stretcher | 1.5 | | |
| | | Felt Whipper | 2.0 | | |
| | | Jordans | 2.0 | | |
| | | Log Haul | 2.0 | | |

* Service Factors in this table are for driven equipment based on smooth prime movers such as electric motors and turbines. For reciprocating prime movers, such as diesel or gas engines, add the following to the Service Factor:
 For 8 or more cylinders, add 0.5
 For 6 cylinders, add 1.0
 For 4 cylinders, add 1.5
 For less than 4 cylinders, consult Rexnord Industries, Inc.

THOMAS® FLEXIBLE DISC COUPLINGS

SELECTION EXAMPLE

A 250 HP electric motor is driving a dredge pump at 1,800 RPM. The shaft size of the motor is 2 $\frac{3}{8}$ the shaft of the pump is 2 $\frac{1}{8}$. The distance between the shaft ends (DBSE) is 5 inches. The environment is 150° F.

$$\text{HP/100 RPM} = \frac{250 \text{ HP} \times 100}{1800 \text{ RPM}} = 13.89 \text{ HP/100 RPM}$$

OR

$$\text{Application Torque} = \frac{250 \text{ HP} \times 63,000}{1,800} = 8,750 \text{ lb.-in.}$$

Service factor (See typical service factor on page 8) = 2.0
Use chart on page 17 for HP/RPM

OR

Application torque requirements × Service factor – 8,750 × 2 = 17,500
Excerpt of page 17 – Series 52

| Coupling Size | ⑥ Max. Bore | A | B | ② Std. C | ② Stocked C | Min. C |
|---------------|-------------|------|------|----------|-------------|--------|
| 125 | 1.38 | 3.69 | 1.31 | 4.00 | 4 | – |
| 162 | 1.88 | 4.34 | 1.75 | 5.00 | 5 | 2.03 |
| 200 | 2.25 | 5.44 | 2.06 | 5.00 | 5 | 2.63 |
| 225 | 2.63 | 5.69 | 2.63 | 5.00 | 5 & 7 | 2.75 |
| 262 | 3.13 | 6.62 | 2.88 | 5.00 | 5 & 7 | 3.22 |
| 312 | 3.63 | 7.81 | 3.38 | 5.50 | 5.5 & 7 | 3.75 |

| Coupling Size | Max Horsepower Per 100 RPM | ③ Max. RPM | | Max. Continuous Torque (lb.-in.) | Peak Weight Overload Torque (lb.-in.) |
|---------------|----------------------------|--------------|----------|----------------------------------|---------------------------------------|
| | Service Factor | ⑤ | | | |
| | | Not Balanced | Balanced | | |
| 125 | 4.28 | 5,000 | 15,000 | 2,700 | 5,400 |
| 162 | 8.49 | 4,600 | 15,000 | 5,350 | 10,700 |
| 200 | 16.7 | 4,250 | 15,000 | 10,500 | 21,000 |
| 225 | 27.8 | 4,100 | 14,000 | 17,500 | 35,000 |
| 262 | 52.1 | 3,900 | 13,000 | 32,830 | 65,660 |
| 312 | 81.6 | 3,450 | 11,700 | 51,400 | 102,800 |

Torque requirements suggest a size 225
Bore size requirement indicates a size 225 is required
DBSE requirement is met by 225 with standard 5 inch C dimension

Coupling Selection = Series 52, Size 225 with standard 5" dimension

THOMAS® FLEXIBLE DISC COUPLINGS

ORDERING INSTRUCTIONS

PROCEDURES

The following bore will be furnished when tolerance and type of fit are not specified. (Does not apply to miniature and DBZ stocked bores.)

| Nominal Bore Dia. | | |
|-------------------|-------|----------------|
| Over | Thru | Bore Tolerance |
| ... | 1 1/2 | +0.0000-0.0005 |
| 1 1/2 | 3 | +0.0000-0.001 |
| 3 | 6 | +0.0000-0.0015 |
| 6 | 12 | +0.0000-0.002 |

See page 11 for types of fits and shaft diameters.

1. Quantity
2. Coupling Size and Type
3. Bore Sizes
4. Keyway and Setscrew Sizes (if non-standard)
5. Dynamic Balancing if required
6. Additional Data (where applicable)
 - (a) Disc Pack material (if other than Tomaloy).
 - (b) Free or interference fit on shafts (if shaft diameters are

given).

- (c) Complete details on tapered bore requirements, see below.
- (d) On DBZ-A Couplings
 - (1) Identify bore of standard hub, and bore of extended hub.
- (e) On SN, SF, and SV Couplings
 - (1) Corrosion Resistance Class
 - (2) "L" Dimension
 - (3) Dynamic Balancing if required
 - (4) Sketch of Stub shaft (SF only) if non-standard
 - (5) On SV, identify bore of upper hub and lower hub
 - (6) Operating speed required
- (f) On BMR Couplings
 - (1) Solid Shaft Diameter, if ordered
 - (2) "L" Dimension
- (g) On CMR Couplings
 - (1) Adapter; 25
 - (a) Outside Diameter
 - (b) Bolt Circle Diameter
 - (c) Bolt Hole Diameter
 - (d) Number of Bolts and Spacing

REX® THOMAS® FLEXIBLE DISC COUPLINGS

ORDERING INFORMATION

TAPERED BORES

INFORMATION REQUIRED

1. Drawing of HUB showing complete bore and keyway details.
- OR —
2. Drawing of SHAFT with dimensions shown below, allowing Rexnord to bore hubs to suit.

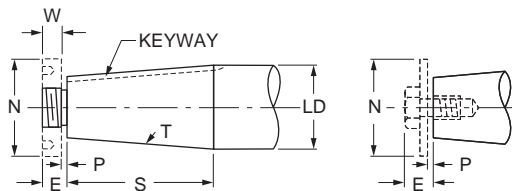

- (LD) Large Diameter, Specify in Decimals.
 (S) Length of Taper, Measure parallel to Shaft centerline.
 (T) Taper per Foot, Difference in Diameter in one foot length.
 (P) Clearance space for drawing Hub up on tapered shaft.
 Usually 1/8" or 1/4", depending on shaft size and taper.

Keyway: Width, Depth.

Note: Specify if keyway is parallel to Taper or if parallel to shaft center line.

Specify depth at larger diameter of Taper if keyway is parallel to shaft center line.

SUPPLEMENTAL TAPER BORE INFORMATION

With connected equipment in fixed position, the following additional information is necessary:

Dimensions "V" and "X" must be given when one or both connected machines are fixed on their bases. Advise if dimension "X" is fixed, or if variable between what limits.

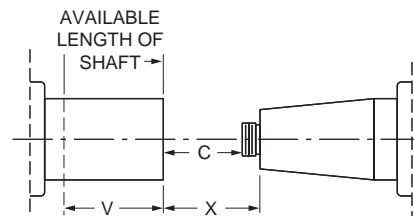

A fixed "X" dimension may require altered or special coupling hubs. Often the straight bored hub can be positioned on its shaft allowing the use of a standard coupling. See illustrations below.

Consult AGMA Standard 9002-A86 "Taper Bores for Flexible Couplings" for new applications.

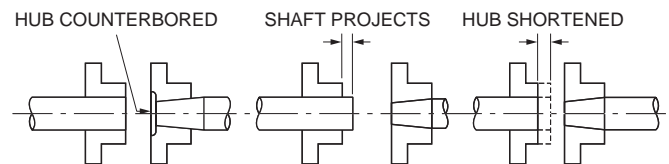

THOMAS® FLEXIBLE DISC COUPLINGS

ORDERING INFORMATION

BORE SPECIFICATIONS

Couplings will be bored in accordance with AGMA Standard 9002-A86. The type of bore fit normally supplied by Rexnord is listed below.

| | |
|---|--|
| DBZ | Straight Bore – Class I Clearance Fit – Stocked Straight Bore – Interference Fit on Bore-To-Order Sizes ① Taper Bore – To Customer Specification |
| AMR, BMR, CMR, SN, SF, SV, ST, 52, 54RDG, 71 | Straight Bore – Interference Fit on All Bores ① Taper bore – To Customer Specification |
| Series 63/THP | All Bores per Customer Specification |
| Miniatures | See page 34-36 |

① Unless specified otherwise by customer.

Note: Rexnord recommends an interference fit be used whenever possible.

| Bore Size | 50 | 62 | 75 | 101 | 126 | 163 | 201 | 226 | 263 |
|-----------|----|----|----|-----|-----|-----|-----|-----|-----|
| .375 | • | | | | | | | | |
| .50 | • | | | | | | | | |
| .625 | | • | | | | | | | |
| .75 | | | • | | | | | | |
| .875 | | | | • | | | | | |
| 1.00 | | | | | • | | | | |
| 1.125 | | | | | | • | | | |
| 1.25 | | | | | | | • | | |
| 1.375 | | | | | | | | • | |
| 1.50 | | | | | | | | | • |
| 1.625 | | | | | | | | | |
| 1.875 | | | | | | | | | |
| 2.00 | | | | | | | | | |
| 2.125 | | | | | | | | | |
| 2.375 | | | | | | | | | |

Standard Keyways Dimensions – Tolerances (inch)

| Nominal Shaft Diameter | | Keyway | | | Keyway Tolerance | | Depth |
|------------------------|-------|--------|-------|---------|------------------|-----------------|------------------|
| | | Width | Depth | | Close Side Fit ③ | Free Side Fit ④ | |
| Over | Thru | | Sq. ② | Rect. ② | | | |
| 5/16 | 7/16 | 3/32 | 3/64 | ... | | | +0.015 -0.000 |
| 7/16 | 9/16 | 1/8 | 1/16 | 3/64 | | | |
| 9/16 | 7/8 | 3/16 | 3/32 | 1/16 | +0.0005 | +0.002 | |
| 7/8 | 1 1/4 | 1/4 | 1/8 | 3/32 | -0.0015 | -0.000 | |
| 1 1/4 | 1 3/8 | 5/16 | 5/32 | 1/8 | | | +0.023 -0.000 |
| 1 3/8 | 1 3/4 | 3/8 | 3/16 | 1/8 | +0.0005 | +0.0025 | |
| 1 3/4 | 2 1/4 | 1/2 | 1/4 | 3/16 | -0.0020 | -0.000 | +0.030 -0.000 |
| 2 1/4 | 2 3/4 | 5/8 | 5/16 | 7/32 | | | |
| 2 3/4 | 3 1/4 | 3/4 | 3/8 | 1/4 | +0.0005 | +0.003 | |
| 3 1/4 | 3 3/4 | 7/8 | 7/16 | 5/16 | -0.0025 | -0.000 | |
| 3 3/4 | 4 1/2 | 1 | 1/2 | 3/8 | | | +0.030 -0.000 |
| 4 1/2 | 5 1/2 | 1 1/4 | 5/8 | 7/16 | +0.0010 | +0.0035 | |
| 5 1/2 | 6 1/2 | 1 1/2 | 3/4 | 1/2 | -0.0025 | -0.000 | |
| 6 1/2 | 7 1/2 | 1 3/4 | 7/8 | 3/4 | +0.0010 | +0.004 | |
| 7 1/2 | 9 | 2 | 1 | 3/4 | -0.0030 | -0.000 | |

② Rectangular keyways recommended for shafts over 6 1/2" diameter.

③ Close Side Fit Keyways – Recommended for reversing torque drives or other drives which are vibratory in nature, or where zero backlash is required. Customers must specify if a close side fit keyway is required.

④ AGMA 9002 Fit Keyways – Recommended for use on smooth, unidirectional drives where fitting of key at assembly cannot be tolerated. An AGMA 9002 fit keyway will be furnished on all couplings unless specified by customer.

Bore Sizes (inch)

| Shaft Dia. | Clearance Fit – Class 1 | Interference Fit |
|------------|-------------------------|------------------|
| 1/2 | 0.500-0.501 | 0.4990-0.4995 |
| 5/8 | 0.625-0.626 | 0.6240-0.6245 |
| 3/4 | 0.750-0.751 | 0.7490-0.7495 |
| 7/8 | 0.875-0.876 | 0.8740-0.8745 |
| 1 | 1.000-1.001 | 0.9990-0.9995 |
| 1 1/8 | 1.125-1.126 | 1.1240-1.1245 |
| 1 1/4 | 1.250-1.251 | 1.2490-1.2495 |
| 1 3/8 | 1.375-1.376 | 1.3740-1.3745 |
| 1 1/2 | 1.500-1.501 | 1.4990-1.4995 |
| 1 5/8 | 1.625-1.626 | 1.623-1.624 |
| 1 3/4 | 1.750-1.751 | 1.748-1.749 |
| 1 7/8 | 1.875-1.876 | 1.873-1.874 |
| 2 | 2.000-2.001 | 1.998-1.999 |
| 2 1/8 | 2.1250-2.1265 | 2.123-2.124 |
| 2 1/4 | 2.2500-2.2515 | 2.248-2.249 |

| Shaft Dia. | Clearance Fit – Class 1 | Interference Fit |
|------------|-------------------------|------------------|
| 2 3/8 | 2.3750-2.3765 | 2.373-2.374 |
| 2 1/2 | 2.5000-2.5015 | 2.498-2.499 |
| 2 5/8 | 2.6250-2.6265 | 2.623-2.624 |
| 2 3/4 | 2.7500-2.7515 | 2.748-2.749 |
| 2 7/8 | 2.8750-2.8765 | 2.873-2.874 |
| 3 | 3.0000-3.0015 | 2.998-2.999 |
| 3 1/4 | 3.2500-3.2515 | 3.2470-3.2485 |
| 3 1/2 | 3.5000-3.5015 | 3.4970-3.4985 |
| 3 5/8 | 3.6250-3.6265 | 3.6220-3.6235 |
| 3 3/4 | 3.7500-3.7515 | 3.7470-3.7485 |
| 4 | 4.000-4.0015 | 3.9970-3.9985 |
| 4 1/2 | 4.500-4.502 | 4.4965-4.4980 |
| 5 | 5.000-5.002 | 4.9965-4.998 |
| 5 1/2 | 5.500-5.502 | 5.4960-5.4975 |
| 6 | 6.000-6.002 | 5.9960-5.9975 |

Consult Rexnord for unlisted sizes or bores over 6-inch diameter.

TAPER-LOCK AND QD BUSHING SELECTION CROSS REFERENCE

In order to cross reference tapered bushing and bore sizes to a coupling selection, the following tables will cover the majority of cases.
* Reg. TM of others.

Taper-Lock* Type

| Bushing Size | Coupling Size and Type | | | | | |
|--------------|------------------------|-----|------------|-----------|--------------|-------------------|
| | Maximum Bore | DBZ | SV, SF, SN | Series 52 | Series 54RDG | AMR, BMR, CMR, ST |
| 1108 | 1 1/8 | 126 | 125 | 125 | 162 | 162 |
| 1215 | 1 1/4 | 163 | 162 | 162 | 200 | 200 |
| 1310 | 1 3/8 | 201 | 200 | 200 | 200 | 200 |
| 1610 | 1 5/8 | 201 | 200 | 200 | 200 | 200 |
| 1615 | 1 5/8 | 201 | 200 | 200 | 225 | 200 |
| 2012 | 2 | 226 | 226 | 225 | 262 | 262 |
| 2517 | 2 1/2 | 263 | 262 | 262 | 312 | 312 |
| 2525 | 2 1/2 | 263 | 262 | 262 | 312 | 262 |
| 3020 | 3 | 351 | 350 | 350 | 375 | 375 |
| 3030 | 3 | 351 | 312 | 312 | 350 | 350 |
| 3535 | 3 1/2 | 401 | 375 | 375 | 450 | 425 |

Note: "C" Dimension will be as listed for all couplings.

"F" Dimension will vary according to bushing selection.

Consult Rexnord for "F" dimensions with bushings.

Note: Dimensions subject to change. Certified dimensions of ordered material furnished on request.

Hubs bored for Q.D. or Taper-Lock® bushings will be modified for proper fit with bushing length. Consult Rexnord Industries, Inc. for specific dimensional data.

If specific reference to the coupling series or type is not found in the table, i.e. special designs, comparison of the shaft size with the maximum bore table only, will indicate the correct taper bushing in the left side of each table. Other flange style and compression bushings can be used with coupling hubs.

Q.D. Type

| Bushing Size | Coupling Size and Type | | | | | | |
|--------------|------------------------|-----|------------|-----------|--------------|-----------|-------------------|
| | Maximum Bore | DBZ | SV, SF, SN | Series 52 | Series 54RDG | Series 71 | AMR, BMR, CMR, ST |
| JA | 1 1/4 | 126 | 125 | 125 | 162 | 150 | 162 |
| SH | 1 5/8 | 163 | 162 | 200 | 200 | 175 | 200 |
| SDS | 1 15/16 | 201 | 226 | 225 | 225 | 300 | 200 |
| SD | 1 15/16 | 201 | 226 | 225 | 225 | 300 | 200 |
| SK | 2 1/2 | 263 | 262 | 262 | 312 | 300 | 262 |
| SF | 2 15/16 | 301 | 312 | 350 | 350 | 350 | 312 |
| E | 3 7/16 | 401 | 375 | 375 | 425 | 462 | 375 |
| F | 3 15/16 | — | 450 | 450 | 500 | 512 | 450 |

⑤ With shallow keyway. Key supplied with bushing where shallow keyway is furnished.

THOMAS® FLEXIBLE DISC COUPLINGS

GENERAL ALIGNMENT INSTRUCTIONS

Correct installation and alignment will assure long life and smooth, trouble free service. Refer to specific instruction sheet, which accompanies shipment, for style of coupling being installed.

Two methods are commonly accepted:

1. Reverse Indicator Method (**preferred**)
2. Face/Rim Method (angular/offset)

For complete alignment information, contact Rexnord Industries, Inc.

THE REVERSE INDICATOR METHOD

1. Rigidly mount a dial indicator on one hub or shaft, reading the shaft or other hub out side diameter as shown. Compensate for indicator set-up sag. Rotate both shafts together. Adjust the equipment by shimming and/or moving so that the indicator reading is within maximum allowable variations for the coupling style.
2. Reverse the set-up as shown and repeat #1 above.
3. When the results of #1 and #2 above are both within maximum allowable variations for the coupling style the shafts are in good alignment.

Angular Alignment. Rigidly mount a dial indicator on one hub or shaft, reading the face of the other hub flange, as shown in Figure 2. Rotate both shafts together making sure the shaft axial spacing remains constant. Adjust the equipment by shimming and/or moving so that the indicator reading is within maximum allowable variations for the coupling style.

Parallel Offset. Rigidly mount a dial indicator on one hub or shaft, reading the other hub flange outside diameter, as shown in Figure 3. Indicator set-up sag must be compensated for. Rotate both shafts together. Adjust the equipment by shimming and/or moving so that the indicator reading is within maximum allowable variations for the coupling style.

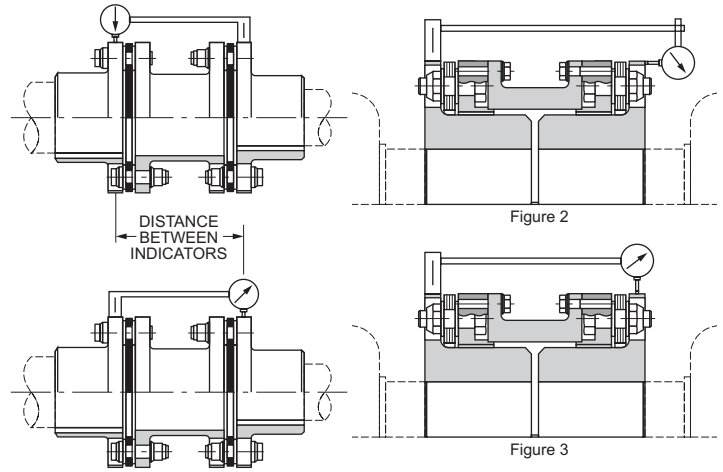

LOCKNUT TIGHTENING TORQUES

Properly tightened locknuts are essential in achieving maximum coupling torque. This table suggests the approximate locknut tightening torque values of disc couplings. Torque should be measured at the locknut while it is being turned.

The tightening torques apply to locknuts as received from the factory. If plated hardware is used, tightening torque must be modified to suit.

Stainless steel hardware requires special consideration. The tightening torques must be reduced to 60% of the values shown. Bolt and locknut threads must also be liberally coated with a

molybdenum disulphide grease if using stainless steel hardware.

Bolting instructions for Series 63 Couplings are included with coupling installation procedures.

Disc Couplings
Approximate Locknut Torque – lb.-ft.

| Coupling Size | Coupling Types | | Coupling Size | Coupling Types | |
|---------------|--------------------------------|---|---------------|--------------------------------|---|
| | DBZ DBZ-A DBZ-B DBZ-C | SN, SF, SV, AMR, BMR, ST 52, 54RDG | | DBZ DBZ-A DBZ-B DBZ-C | SN, SF, SV, AMR, BMR, ST 52, 54RDG |
| 50 | 2 | 2 | 312 | – | 40 |
| 62 | 3 | 3 | 350 | – | 95 |
| 75 | 3 | 3 | 351 | 175 | – |
| 100 | – | 8 | 375 | – | 130 |
| 101 | 8 | – | 401 | 150* | – |
| 125 | – | 13 | 425 | – | 175 |
| 126 | 13 | – | 450 | – | 150* |
| 162 | – | 13 | 451 | 190* | – |
| 163 | 13 | – | 500 | – | 190* |
| 200 | – | 25 | 550 | – | 255* |
| 201 | 25 | – | 600 | – | 335* |
| 225 | – | 25 | 700 | – | 425* |
| 226 | 30 | 25 | 750 | – | 560* |
| 262 | – | 30 | 800 | – | 740* |
| 263 | 40 | – | 850 | – | 950* |
| 301 | 95 | – | 925 | – | 1,800 |

Note:

1. These torque values are approximate for steel bolts with oil lubricated threads.
2. Bolts should be held from rotating while the locknuts are torqued to the values shown.

* These locknuts are cadmium plated.

Series 71
Locknut and Capscrew Tightening Torques

| Coupling Size | Locknut Torque lb.-ft. (lb.-in.) | Capscrew Torque lb.-ft. (lb.-in.) |
|---------------|----------------------------------|-----------------------------------|
| 150 | (130) | (113) |
| 175 | (162) | (108) |
| 225 | (162) | (108) |
| 300 | 25 | (108) |
| 350 | 34 | 18 |
| 376 | 60 | 18 |
| 412 | 80 | 18 |
| 462 | 130 | 33 |
| 512 | 164 | 52 |
| 562 | 190* | 80 |
| 600 | 190* | 80 |
| 712 | 190* | 95 |
| 800 | 255* | 165 |
| 875 | 335* | 270 |
| 1038 | 425* | 270 |

APPLICATION DATA FORM – ENGINEERED PRODUCTS

Rex[®] Thomas[®] couplings are adaptable to virtually any special drive system.
 Please fill out this page and the facing page and send to Rexnord Industries, Inc.
 Coupling Operation, Warren, PA 16365. Telephone: (814) 723-6600.

NAME: _____

TITLE: _____

COMPANY: _____

ADDRESS: _____

PHONE: _____

DATE: ____ / ____ / ____

APPLICATION DATA

DRIVER: _____

DRIVEN: _____

NEW APPL.: Yes No

REPLACING: _____

SERVICE: Cont. Intermitt.

TEMP.: Norm. _____ °F Max. _____ °F

SERVICE FACTOR: _____

CORROSION PROTECTION: Yes No

PLATE/COAT.: _____

THERMAL GROWTH:

BSE (Cold): _____

BSE (Hot): _____

AXIAL FLOAT REQ'D.±: _____

CUSTOMER REQUIREMENTS

WT: Solo Plate

WR2: WT/2 — CG Simulator

KT: Puller Holes

CG: Sketch

NCR: Dwg.

FN: Quote

BALANCE CPLG.: Yes No

BALANCE HUBS: No

DR.: DN.

FIELD BAL. TAPS: Yes No

OTHER: _____

INQUIRY NO. T: _____

COUPLING OPERATION DATA

DATE QUOTED: ____ / ____ / ____

CPLG. SIZE/STYLE: _____

DESIGN: Std. Rm. Spec.

ORDER NO.: _____

DWG. NO.: _____

QTY.: _____

PRICE: _____

DELIVERY: _____

TORQUE DATA

| | NOR. | MAX. | START | TRIP |
|------------------|-------|-------|-------|-------|
| H.P.: | _____ | _____ | _____ | _____ |
| kW: | _____ | _____ | _____ | _____ |
| RPM: | _____ | _____ | _____ | _____ |
| Torque (In-Lbs): | _____ | _____ | _____ | _____ |

SPECIFICATION APPLICABLE

API-671: Yes No EDITION _____

API-610: Yes No EDITION _____

OTHER: _____

DESIGN LIMITS

WEIGHT: Yes No — _____ lbs.

WR2: Yes No — _____ lbs.-in.²

KT: Yes No — _____ x 10⁶ in.-lb./Rad.

O.D.: Yes No — _____ in.

MISALIGNMENT: Yes No

ANG.: _____ Deg./Element

PARA.: _____ in. Offset

Axial ±: _____ in.

OTHER: _____

SPECIAL NOTES: _____

THOMAS® FLEXIBLE DISC COUPLINGS

CLOSE-COUPLED SERIES 54RDG

Series 54RDG couplings are reduced diameter gear and grid replacement couplings. Applications include any situation where the overall shaft to shaft spacing is minimal. The center member of the 54RDG is split axially, which permits maintenance of the couplings without moving the hubs or the connected equipment. Center member is piloted into the adapter providing high speed potential at high torque density.

Construction

Hubs and Center members: Carbon Steel
 Bolts: Alloy Steel
 Disc Packs: Stainless Steel
 Coatings Available: Black Oxide, Zinc, Cadmium

Other materials such as Tomaloy, Monel and Inconel are available; please consult Rexnord Industries, Inc.

Misalignment: 1/8° per disc pack

When Specified, Series 54RDG couplings meet all requirements of API 610, or API 671. If application requires API specification, please consult Rexnord Industries, Inc.

****NEW DESIGN****

****INCREASED TORQUE RATINGS****

General Dimensions (inch)

| Coupling Size | Max Bore* Internal | Max Bore* External | A | B | C | C1** | F | F1** | H | N | G | C2*** | F2*** |
|---------------|--------------------|--------------------|-------|------|------|------|-------|-------|------|------|-------|-------|-------|
| 125 | 1.188 | 1.375 | 3.81 | 1.88 | 0.12 | 1.75 | 3.88 | 4.94 | 0.17 | 0.27 | 1.75 | 3.38 | 6.00 |
| 162 | 1.625 | 1.875 | 4.47 | 1.88 | 0.12 | 1.77 | 3.88 | 5.40 | 0.17 | 0.29 | 2.34 | 3.42 | 6.92 |
| 200 | 2.250 | 2.250 | 5.56 | 2.12 | 0.12 | 1.96 | 4.36 | 6.14 | 0.22 | 0.36 | 3.25 | 3.80 | 7.92 |
| 225 | 2.375 | 2.625 | 5.88 | 2.19 | 0.12 | 2.03 | 4.50 | 6.84 | 0.22 | 0.36 | 3.50 | 3.94 | 9.18 |
| 262 | 2.750 | 3.125 | 6.88 | 2.59 | 0.19 | 2.42 | 5.37 | 7.89 | 0.25 | 0.47 | 4.12 | 4.65 | 10.41 |
| 312 | 3.375 | 3.625 | 7.84 | 2.84 | 0.19 | 2.62 | 5.87 | 8.84 | 0.30 | 0.50 | 5.00 | 5.05 | 11.81 |
| 350 | 3.750 | 4.000 | 8.78 | 3.28 | 0.25 | 3.06 | 6.81 | 10.09 | 0.34 | 0.54 | 5.50 | 5.87 | 13.37 |
| 375 | 4.188 | 4.500 | 9.72 | 3.56 | 0.25 | 3.26 | 7.37 | 10.82 | 0.39 | 0.59 | 6.06 | 6.27 | 14.27 |
| 425 | 4.500 | 4.750 | 10.50 | 3.97 | 0.25 | 3.61 | 8.19 | 11.83 | 0.42 | 0.62 | 6.56 | 6.97 | 15.47 |
| 450 | 4.750 | 5.125 | 11.31 | 4.50 | 0.31 | 4.15 | 9.31 | 13.15 | 0.47 | 0.71 | 7.00 | 7.99 | 16.99 |
| 500 | 5.000 | 5.375 | 12.88 | 4.78 | 0.31 | 4.32 | 9.87 | 14.10 | 0.50 | 0.78 | 7.88 | 8.33 | 18.33 |
| 550 | 5.500 | 6.000 | 14.44 | 5.37 | 0.38 | 4.87 | 11.12 | 15.74 | 0.58 | 0.91 | 8.75 | 9.36 | 20.36 |
| 600 | 6.000 | 6.500 | 16.00 | 6.00 | 0.38 | 5.40 | 12.38 | 17.40 | 0.67 | 0.98 | 9.31 | 10.42 | 22.42 |
| 700 | 7.000 | 7.500 | 18.25 | 7.00 | 0.38 | 6.22 | 14.38 | 20.22 | 0.75 | 1.20 | 10.88 | 12.06 | 26.06 |
| 750 | 7.500 | 8.000 | 19.81 | 7.75 | 0.50 | 7.00 | 16.00 | 22.25 | 0.84 | 1.27 | 11.75 | 13.50 | 28.50 |
| 800 | 8.000 | 8.750 | 21.50 | 8.25 | 0.50 | 7.37 | 17.00 | 23.87 | 0.91 | 1.34 | 12.50 | 14.24 | 30.74 |
| 850 | 8.500 | 9.250 | 23.00 | 8.88 | 0.56 | 7.97 | 18.32 | 25.60 | 1.00 | 1.40 | 13.19 | 15.38 | 32.88 |
| 925 | 9.000 | 10.125 | 25.00 | 9.91 | 0.62 | 8.91 | 20.44 | 28.32 | 1.09 | 1.50 | 14.12 | 17.20 | 36.20 |

* Non-bored hubs available upon request.

** Hubs may be reversed for alternate shaft spacing

*** Both hubs reversed



Patent Pending

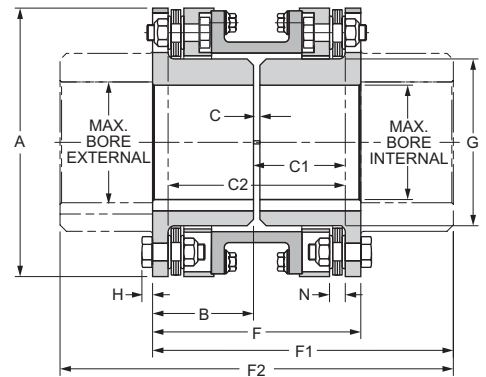

Engineering Data

| Coupling Size | Max Horsepower Per 100 RPM | Maximum RPM | | Maximum Continuous Torque (lb.-in.) | Peak Overload Torque (lb.-in.) | ② Weight (lb.) | ⑤ WR ² (lb.-in. ²) | Axial Capacity (in.) |
|---------------|----------------------------|----------------|------------|-------------------------------------|--------------------------------|----------------|---|----------------------|
| | | ① Not Balanced | ① Balanced | | | | | |
| | | | | | | | | |
| 125 | 4.3 | 4,600 | 10,500 | 2,700 | 5,400 | 6.9 | 12.5 | ±0.036 |
| 162 | 8.5 | 4,200 | 9,700 | 5,350 | 10,700 | 9.3 | 24.0 | ±0.036 |
| 200 | 16.7 | 3,800 | 8,600 | 10,500 | 21,000 | 16 | 67.0 | ±0.036 |
| 225 | 27.8 | 3,700 | 8,400 | 17,500 | 35,000 | 19 | 85.0 | ±0.036 |
| 262 | 52.1 | 3,600 | 7,400 | 32,830 | 65,660 | 31 | 192 | ±0.043 |
| 312 | 81.6 | 3,000 | 6,700 | 51,400 | 102,800 | 46 | 384 | ±0.051 |
| 350 | 106 | 2,800 | 6,200 | 66,900 | 133,800 | 66 | 689 | ±0.056 |
| 375 | 159 | 2,500 | 4,800 | 100,300 | 200,600 | 88 | 1,160 | ±0.062 |
| 425 | 213 | 2,300 | 5,400 | 134,300 | 268,600 | 117 | 1,780 | ±0.067 |
| 450 | 239 | 2,200 | 5,000 | 150,400 | 300,800 | 154 | 2,690 | ±0.072 |
| 500 | 391 | 2,000 | 4,600 | 246,400 | 492,800 | 224 | 4,970 | ±0.082 |
| 550 | 524 | 1,900 | 4,200 | 330,400 | 660,800 | 324 | 8,970 | ±0.092 |
| 600 | 688 | 1,800 | 3,900 | 433,800 | 867,600 | 437 | 14,900 | ±0.102 |
| 700 | 1,071 | 1,700 | 3,600 | 674,800 | 1,349,600 | 657 | 29,000 | ±0.115 |
| 750 | 1,331 | 1,550 | 3,400 | 838,800 | 1,677,600 | 839 | 43,400 | ±0.125 |
| 800 | 1,712 | 1,450 | 3,200 | 1,078,700 | 2,157,400 | 1,040 | 63,900 | ±0.136 |
| 850 | 2,020 | 1,350 | 3,000 | 1,273,000 | 2,546,000 | 1,260 | 88,900 | ±0.144 |
| 925 | 2,735 | 1,300 | 2,800 | 1,724,000 | 3,448,000 | 1,690 | 140,000 | ±0.156 |

For ordering instructions, see Page 10-11.

① See page 7 for explanation of RPM limits and balancing recommendations.

② Weight and WR² with standard length hubs, maximum bore and standard "C".

③ Extended hub length is designed longer in order to include a counter-bore for the threaded extension on a tapered shaft.

④ Large hub length. For sizes not shown, consult Rexnord.

⑤ All Thomas disc couplings meet NEMA frame sleeve bearing motor specifications without modifications or the addition of end-float restricting devices.

Note: Dimensions subject to change. Certified dimensions of ordered material furnished on request.

THOMAS® FLEXIBLE DISC COUPLINGS

CLOSE-COUPLED TYPES DBZ, DBZ-A, DBZ-B

The standard DBZ coupling has two hubs inverted inside the disc pack and is used where overall shaft to shaft spacing is minimal.

DBZ style has both hubs with inverted orientation.

DBZ-A style has one hub extended to permit taper boring.

DBZ-B style has both hubs extended to allow for greater spacing where required.

Construction

Hubs and Center Assembly: Carbon Steel

Bolts: Alloy Steel

Disc Packs: Tomaloy

Coatings Available: Black Oxide, Zinc, Cadmium

Other materials such as Stainless Steel, Monel and Inconel are available; please consult Rexnord Industries, Inc.

Misalignment: 1/2° per disc pack

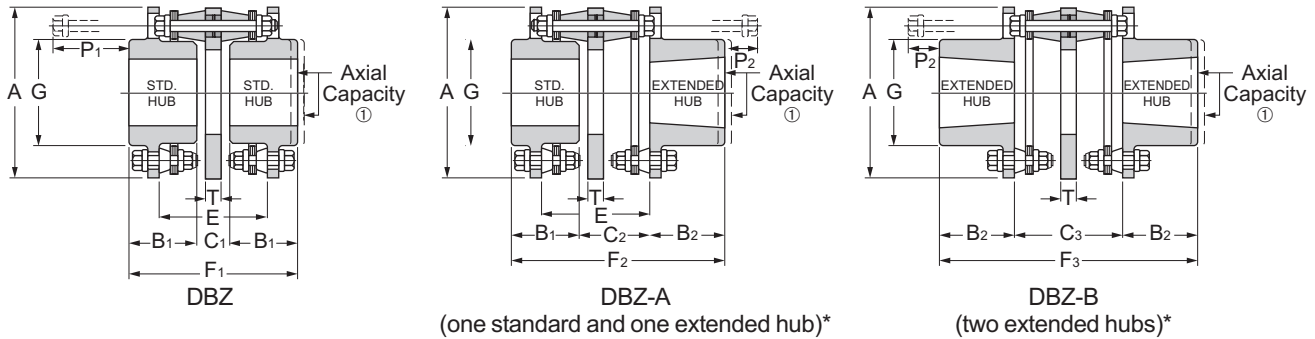

General Dimensions (inch)

| Coupling Size | Standard Hub Maximum Bore | Extended Hub Maximum Bore | A | B1 | B2 | C1 | C2 | C3 | E | F1 | F2 | F3 | G | P1 | P2 | T |
|---------------|---------------------------|---------------------------|-------|------|------|------|------|------|------|-------|-------|-------|------|------|------|------|
| | | | | | | | | | | | | | | | | |
| 50 | 0.63 | 0.63 | 2.00 | 0.88 | 0.88 | 0.32 | 0.84 | 1.36 | 1.36 | 2.08 | 2.60 | 3.12 | 1.00 | 1.25 | 0.78 | 0.19 |
| 62 | 0.75 | 0.75 | 2.44 | 1.09 | 1.09 | 0.38 | 1.05 | 1.72 | 1.72 | 2.56 | 3.23 | 3.90 | 1.19 | 1.56 | 1.06 | 0.25 |
| 75 | 0.88 | 0.88 | 2.69 | 1.12 | 1.12 | 0.37 | 1.06 | 1.75 | 1.75 | 2.61 | 3.30 | 3.99 | 1.44 | 1.56 | 1.06 | 0.25 |
| 101 | 1.13 | 1.16 | 3.22 | 1.38 | 1.38 | 0.69 | 1.39 | 2.08 | 2.08 | 3.45 | 4.15 | 4.84 | 1.69 | 1.69 | 1.00 | 0.31 |
| 126 | 1.38 | 1.38 | 3.84 | 1.50 | 1.62 | 0.96 | 1.70 | 2.45 | 2.45 | 3.96 | 4.82 | 5.69 | 2.06 | 2.00 | 1.13 | 0.41 |
| 163 | 1.88 | 1.88 | 4.56 | 1.69 | 1.88 | 0.95 | 1.70 | 2.45 | 2.45 | 4.33 | 5.27 | 6.21 | 2.75 | 1.81 | 0.88 | 0.41 |
| 201 | 2.13 | 2.25 | 5.34 | 1.94 | 2.12 | 0.96 | 1.96 | 2.96 | 2.96 | 4.84 | 6.02 | 7.20 | 3.28 | 2.31 | 1.13 | 0.56 |
| 226 | 2.38 | 2.63 | 6.06 | 2.38 | 3.62 | 1.22 | 2.53 | 3.84 | 3.84 | 5.98 | 7.53 | 9.08 | 3.78 | 2.69 | 1.13 | 0.66 |
| 263 | 2.88 | 3.00 | 7.00 | 2.75 | 3.00 | 1.31 | 2.81 | 4.31 | 4.31 | 6.81 | 8.56 | 10.31 | 4.44 | 3.00 | 1.25 | 0.75 |
| 301 | 3.13 | 3.50 | 8.00 | 3.12 | 3.44 | 1.50 | 3.19 | 4.88 | 4.88 | 7.74 | 9.75 | 11.76 | 5.06 | 3.56 | 1.56 | 0.84 |
| 351 | 3.63 | 4.00 | 9.38 | 3.69 | 4.06 | 1.80 | 3.86 | 5.92 | 5.92 | 9.18 | 11.61 | 14.04 | 5.81 | 4.50 | 2.06 | 1.06 |
| 401 | 4.13 | 4.50 | 10.69 | 4.19 | 4.62 | 1.94 | 4.32 | 6.70 | 6.70 | 10.32 | 13.13 | 15.94 | 6.63 | 5.13 | 2.31 | 1.19 |
| 451 | 4.63 | 4.75 | 12.13 | 4.75 | 5.25 | 2.12 | 4.72 | 7.28 | 7.28 | 11.66 | 14.72 | 17.78 | 7.38 | 5.44 | 2.38 | 1.34 |

Engineering Data

| Coupling Size | Max. Horsepower Per 100 RPM Service Factor | ③ Max. RPM | | Max. Continuous Torque (lb.-in.) | Peak Overload Torque (lb.-in.) | ④ Weight (lb.) | | | ④ WR ² (lb.-in.) | | | ① Axial Capacity (in.) |
|---------------|---|--------------|----------|----------------------------------|--------------------------------|----------------|-------|-------|-----------------------------|-------|-------|------------------------|
| | | Not Balanced | Balanced | | | DBZ | DBZ-A | DBZ-B | DBZ | DBZ-A | DBZ-B | |
| | | | | | | | | | | | | |
| 50 | 0.23 | 6,000 | 9,000 | 145 | 220 | 0.7 | 0.7 | 0.7 | 0.3 | 0.3 | 0.3 | ±0.023 |
| 62 | 0.39 | 6,000 | 8,200 | 246 | 370 | 1.5 | 1.5 | 1.5 | 0.7 | 0.7 | 0.7 | ±0.028 |
| 75 | 0.56 | 6,000 | 7,800 | 353 | 530 | 1.9 | 1.9 | 1.9 | 1.5 | 1.5 | 1.5 | ±0.032 |
| 101 | 1.10 | 6,000 | 7,100 | 693 | 1,040 | 3.3 | 3.3 | 3.3 | 4.5 | 4.5 | 4.5 | ±0.038 |
| 126 | 2.00 | 5,500 | 6,500 | 1,260 | 1,900 | 5.5 | 5.6 | 5.7 | 9.9 | 10.1 | 10.1 | ±0.046 |
| 163 | 2.70 | 5,000 | 6,000 | 1,700 | 2,600 | 8.4 | 8.6 | 8.8 | 21.0 | 21.0 | 22.0 | ±0.057 |
| 201 | 4.79 | 4,600 | 5,500 | 3,020 | 4,500 | 14.4 | 14.4 | 15.4 | 53.0 | 53.0 | 54.0 | ±0.067 |
| 226 | 8.73 | 4,100 | 5,200 | 5,500 | 8,300 | 21.0 | 22.0 | 23.0 | 95.0 | 95.0 | 105 | ±0.076 |
| 263 | 13.6 | 3,700 | 4,800 | 8,600 | 12,900 | 33.0 | 34.0 | 35.0 | 199 | 209 | 209 | ±0.089 |
| 301 | 20.5 | 3,300 | 4,500 | 12,900 | 19,400 | 50.0 | 52.0 | 54.0 | 365 | 375 | 385 | ±0.102 |
| 351 | 35.9 | 2,900 | 4,100 | 22,600 | 33,900 | 83.0 | 87.0 | 90.0 | 916 | 936 | 965 | ±0.118 |
| 401 | 52.7 | 2,700 | 3,900 | 33,200 | 49,800 | 125 | 125 | 135 | 1,705 | 1,710 | 1,710 | ±0.136 |
| 451 | 68.9 | 2,600 | 3,600 | 43,400 | 65,100 | 170 | 180 | 180 | 3,168 | 3,170 | 3,270 | ±0.154 |

For ordering instructions, see Page 10-11.

① All Thomas disc couplings meet NEMA frame sleeve bearing motor specifications without modification or the addition of end-float restricting devices.

② Popular sized standard hubs bore with keyway and setscrew are stocked. See page 11 for stocked bore sizes.

③ See Page 7 for explanation of RPM limits and balancing recommendations.

④ Weight and WR² at maximum bore.

⑤ Hubs furnished without a finished bore will be solid.

* Extended hubs can be supplied with straight bores or taper bores.

THOMAS® FLEXIBLE DISC COUPLINGS

SPACER TYPE SERIES 52

Series 52 couplings are all purpose high speed, high torque couplings used where minimum coupling weight is desirable. They are commonly used on motor and turbine driven pumps, compressors and fans. Design modifications may be made to further reduce the coupling weight, making it an economic alternative to high performance disc and diaphragm couplings.

Construction

Hubs and Center Assembly: Carbon Steel

Bolts: Alloy Steel

Disc Packs: Tomaloy Tpack™ (225-750 Size)

Coatings Available: Black Oxide, Zinc, Cadmium

When Specified, Series 52 couplings meet all requirements of API 610, or API 671.

If application requires API specification, please consult Rexnord Industries, Inc.

Other materials such as Stainless Steel, Monel and Inconel are available; please consult Rexnord Industries, Inc.

Misalignment: 1/8° per disc pack

****INCREASED TORQUE RATINGS****

| General Dimensions (inch) | | | | | | | | | |
|---------------------------|-------------|-------|-------|----------|-------------|--------|-------|-------|------|
| Coupling Size | ⑥ Max. Bore | A | B | ② Std. C | ② Stocked C | Min. C | F | G | N |
| 125 | 1.38 | 3.69 | 1.31 | 4.00 | 4 | — | 6.63 | 2.06 | 0.27 |
| 162 | 1.88 | 4.34 | 1.75 | 5.00 | 5 | 2.03 | 8.50 | 2.75 | 0.29 |
| 200 | 2.25 | 5.44 | 2.06 | 5.00 | 5 | 2.63 | 9.13 | 3.28 | 0.36 |
| 225 | 2.63 | 5.69 | 2.63 | 5.00 | 5 & 7 | 2.75 | 10.25 | 3.78 | 0.36 |
| 262 | 3.13 | 6.62 | 2.88 | 5.00 | 5 & 7 | 3.22 | 10.75 | 4.50 | 0.47 |
| 312 | 3.63 | 7.81 | 3.38 | 5.50 | 5.5 & 7 | 3.75 | 12.25 | 5.25 | 0.50 |
| 350 | 4.00 | 8.69 | 3.75 | 6.00 | 6 & 7 | 4.16 | 13.50 | 5.88 | 0.54 |
| 375 | 4.50 | 9.69 | 4.00 | 7.00 | 7 | 4.59 | 15.00 | 6.50 | 0.59 |
| 425 | 4.75 | 10.50 | 4.25 | 7.00 | 7 | 4.94 | 15.50 | 7.00 | 0.62 |
| 450 | 5.13 | 11.31 | 4.50 | 8.00 | 7 & 8 | 5.34 | 17.00 | 7.44 | 0.71 |
| 500 | 5.38 | 12.88 | 5.00 | 9.00 | 9 | 6.03 | 19.00 | 8.38 | 0.78 |
| 550 | 6.00 | 14.44 | 5.50 | 10.00 | 10 | 6.88 | 21.00 | 9.44 | 0.91 |
| 600 | 6.50 | 16.00 | 6.00 | 10.00 | 10 | 7.50 | 22.00 | 10.25 | 0.98 |
| 700 | 7.50 | 18.25 | 7.00 | 11.00 | — | 8.56 | 25.00 | 11.75 | 1.20 |
| 750 | 8.00 | 19.81 | 7.50 | 11.00 | — | 9.25 | 26.00 | 12.63 | 1.27 |
| 800 | 8.75 | 21.50 | 8.25 | 12.00 | — | 10.02 | 28.50 | 13.62 | 1.34 |
| 850 | 9.25 | 23.00 | 8.75 | 13.00 | — | 10.75 | 30.50 | 14.50 | 1.40 |
| 925 | 10.12 | 25.00 | 9.50 | 14.00 | — | 11.50 | 33.00 | 15.75 | 1.50 |
| 1000 | 11.00 | 27.50 | 10.50 | 14.50 | — | — | 35.50 | 17.25 | 1.69 |
| 1100 | 12.00 | 29.19 | 11.25 | 16.00 | — | — | 38.50 | 18.50 | 1.75 |
| 1200 | 13.00 | 32.12 | 12.25 | 17.00 | — | — | 41.50 | 20.25 | 1.97 |
| 1300 | 14.00 | 34.50 | 13.25 | 18.00 | — | — | 44.50 | 21.88 | 2.03 |

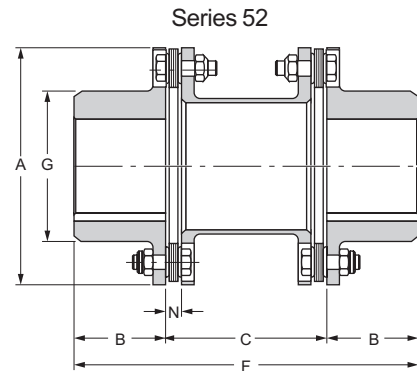

Series 52
TAPER BORES ALSO AVAILABLE

Engineering Data

| Coupling Size | Max Horsepower Per 100 RPM | ③ Maximum RPM | | Maximum Continuous Torque (lb.-in.) | Peak Overload Torque (lb.-in.) | ④ Weight (lb.) | Weight Change Per inch of "C" (lb.) | ④ WR ² (lb.-in. ²) | WR ² Change Per Inch of "C" (lb.-in. ²) | ① Axial Capacity (in.) |
|---------------|----------------------------|---------------|----------|-------------------------------------|--------------------------------|----------------|-------------------------------------|---|--|------------------------|
| | Service Factor | ⑤ | | | | | | | | |
| | | Not Balanced | Balanced | | | | | | | |
| 125 | 4.28 | 5,000 | 15,000 | 2,700 | 5,400 | 4.6 | 0.16 | 7.4 | 0.15 | ±0.036 |
| 162 | 8.49 | 4,600 | 15,000 | 5,350 | 10,700 | 7.2 | 0.21 | 15.8 | 0.27 | ±0.036 |
| 200 | 16.7 | 4,250 | 15,000 | 10,500 | 21,000 | 12.4 | 0.25 | 43.7 | 0.58 | ±0.036 |
| 225 | 27.8 | 4,100 | 14,000 | 17,500 | 35,000 | 16.0 | 0.35 | 61 | 0.85 | ±0.036 |
| 262 | 52.1 | 3,900 | 13,000 | 32,830 | 65,660 | 26.0 | 0.50 | 137 | 1.6 | ±0.043 |
| 312 | 81.6 | 3,450 | 11,700 | 51,400 | 102,800 | 41.4 | 0.66 | 300 | 3.1 | ±0.051 |
| 350 | 106 | 3,200 | 10,500 | 66,900 | 133,800 | 58.6 | 0.83 | 528 | 4.8 | ±0.056 |
| 375 | 159 | 3,000 | 9,400 | 100,300 | 200,600 | 80.0 | 1.03 | 909 | 7.2 | ±0.062 |
| 425 | 213 | 2,800 | 8,700 | 134,300 | 268,600 | 104.0 | 1.43 | 1,380 | 11.7 | ±0.067 |
| 450 | 239 | 2,700 | 8,100 | 150,400 | 300,800 | 127 | 1.44 | 1,970 | 13.5 | ±0.072 |
| 500 | 391 | 2,500 | 7,100 | 246,400 | 492,800 | 196 | 2.30 | 3,800 | 27.2 | ±0.082 |
| 550 | 524 | 2,300 | 6,300 | 330,400 | 660,800 | 281 | 2.90 | 6,900 | 43.0 | ±0.092 |
| 600 | 688 | 2,150 | 5,700 | 433,800 | 867,600 | 370 | 3.30 | 11,200 | 61.2 | ±0.102 |
| 700 | 1,071 | 1,950 | 5,000 | 674,800 | 1,349,600 | 567 | 4.60 | 22,300 | 103.0 | ±0.115 |
| 750 | 1,331 | 1,850 | 4,600 | 838,800 | 1,677,600 | 712 | 5.20 | 33,100 | 143.0 | ±0.125 |
| 800 | 1,712 | 1,750 | 4,300 | 1,078,700 | 2,157,400 | 911 | 6.00 | 51,450 | 200.0 | ±0.136 |
| 850 | 2,020 | 1,600 | 3,900 | 1,273,000 | 2,546,000 | 1,109 | 6.00 | 71,700 | 200.0 | ±0.144 |
| 925 | 2,735 | 1,500 | 3,600 | 1,724,000 | 3,448,000 | 1,459 | 8.00 | 111,400 | 400.0 | ±0.156 |
| 1000 | 3,094 | — | 3,250 | 1,950,000 | 3,900,000 | 1,880 | 9.00 | 171,900 | 506.0 | ±0.172 |
| 1100 | 3,689 | — | 3,100 | 2,325,000 | 4,650,000 | 2,250 | 11.00 | 235,500 | 794.0 | ±0.183 |
| 1200 | 4,498 | — | 2,800 | 2,835,000 | 5,670,000 | 3,010 | 15.00 | 376,500 | 1,196.0 | ±0.203 |
| 1300 | 5,379 | — | 2,600 | 3,390,000 | 6,780,000 | 3,660 | 15.00 | 523,700 | 1,350.0 | ±0.218 |

① All Thomas disc couplings meet NEMA frame sleeve bearing motor specifications without modification or the addition of end-float restricting devices.

② Additional "C" dimensions available. Consult Rexnord.

③ Series 52 couplings meet AGMA Class 9 balance requirements as manufactured with interference fit bore and close fit keyway. If clearance fit and/or setscrews are required, please consult Rexnord. See page 7 for explanation of RPM limits and balancing recommendations.

④ Weight and WR² at maximum bore and standard "C" dimension listed.

⑤ Balance recommendations based on AGMA Specification 9000-C90 Average Sensitivity.

⑥ Consult Rexnord for minimum rough bore sizes.

Note: Dimensions subject to change. Certified dimensions of ordered material furnished on request.

THOMAS® FLEXIBLE DISC COUPLINGS

SPACER TYPE SERIES 71

Series 71 couplings are designed for applications requiring a spacer-type coupling such as ANSI, API and other process pumps. Series 71 couplings are most commonly applied on motor, turbine, and gear driven pumps, compressors and blowers.

Series 71 is a simple three piece design. Hubs are piloted fit to the factory assembled center member. The piloting provides repeatable assembly of components for better dynamic balance characteristics. The center assembly simply "drops out" for fast installation or removal without special tools. The disc design allows for low flexing forces and high overload capacity.

Construction

Hubs and Center Assembly: Carbon Steel

Bolts: Alloy Steel

Disc Packs: Stainless Steel for 4 & 6 bolt designs Stainless Steel Tpack™ for 8 bolt design

Coatings Available: Black Oxide, Zinc, Cadmium

Other materials such as Monel and Inconel are available; please consult Rexnord Industries, Inc.

Misalignment: 1/2° per disc pack for 4 and 6 bolt designs, 1/3° per disc pack for 8 bolt design

When Specified, Series 71 couplings meet all requirements of API 610, or API 671. If application requires API specification, please consult Rexnord Industries, Inc.

Benefits

Three piece design features unitized center member assembly and two piloted hubs

Unique jacking bolt feature compresses coupling for easy installation and removal of center section assembly.

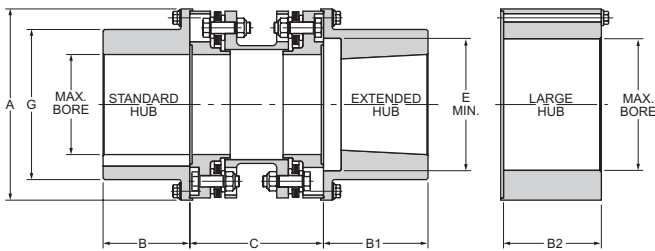

8 Bolt Design

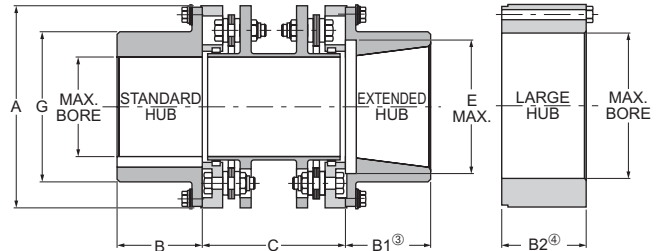

4 & 6 Bolt Design

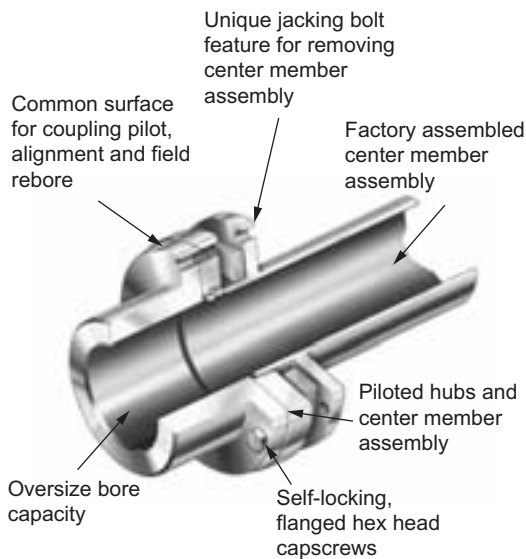

Note:

These recommendations and balance classes are based on AGMA Specifications 9000-C90, high sensitivity. If conditions exist other than as defined in 9000-C90, for sensitivity, consult Rexnord Industries, Inc.. The above information should be used as a guide only. AGMA Class 9 balance is furnished as standard when Series 71 couplings are finished bored with interference fits.

Series 71 Balance Recommendations

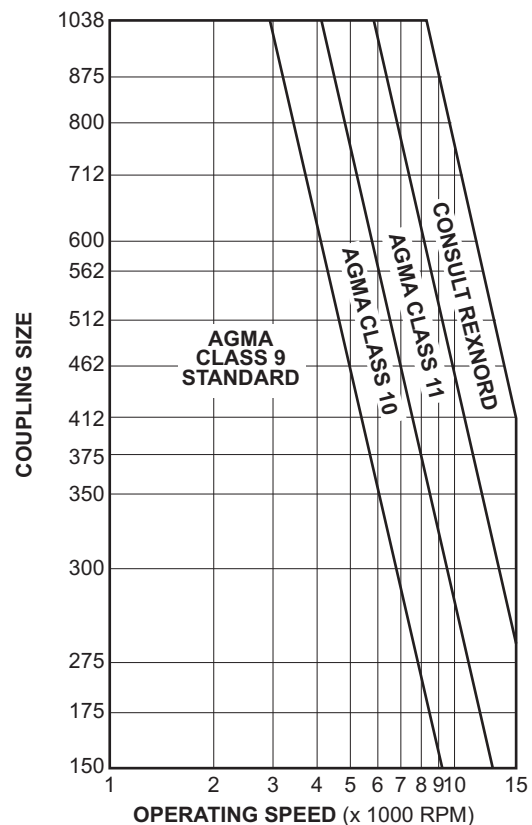

THOMAS® FLEXIBLE DISC COUPLINGS

SPACER TYPE SERIES 71 – 4 & 6 BOLT

General Dimensions (inch)

| Coupling Size | ⑦ B & B ¹ Hub Max. Bore | ⑦ B ² Hub Max. Bore | A | ③ B | ④ B ¹ | Std. B ² | Std. C | Min. C | E | G |
|---------------|------------------------------------|--------------------------------|-------|------|------------------|---------------------|--------|--------|------|------|
| 150 | 1.500 | 2.375 | 3.59 | 1.31 | 1.69 | 1.62 | 3.50 | 3.44 | 2.06 | 2.31 |
| 175 | 1.875 | 2.750 | 4.16 | 1.56 | 2.06 | 1.81 | 3.50 | 3.44 | 2.56 | 2.81 |
| 225 | 2.250 | 3.250 | 4.94 | 2.00 | 2.50 | 2.06 | 5.00 | 3.44 | 3.09 | 3.34 |
| 300 | 3.000 | 4.000 | 5.97 | 2.62 | 3.25 | 2.75 | 5.00 | 4.00 | 4.13 | 4.44 |
| 350 | 3.500 | 4.500 | 6.75 | 3.12 | 3.75 | 3.00 | 5.00 | 4.88 | 5.00 | 5.25 |
| 375 | 3.750 | 5.000 | 7.62 | 3.25 | 4.00 | 3.25 | 5.50 | 5.00 | 5.31 | 5.66 |
| 412 | 4.125 | 5.310 | 8.00 | 3.62 | 4.38 | 3.62 | 7.00 | 6.12 | 5.75 | 6.09 |
| 462 | 4.625 | 6.000 | 9.00 | 4.12 | 5.00 | 4.12 | 7.00 | 7.00 | 6.31 | 6.84 |
| 512 | 5.125 | 6.690 | 10.03 | 4.50 | 5.38 | 4.50 | 7.00 | 7.00 | 7.06 | 7.62 |
| 562 | 5.625 | 7.310 | 10.97 | 5.00 | 6.00 | 5.00 | 8.00 | 8.00 | 7.69 | 8.38 |
| 600 | 6.000 | 7.810 | 11.72 | 5.25 | 6.38 | 5.25 | 9.00 | 9.00 | 8.31 | 8.94 |

Stocked "C" Dimensions

| Coupling Size | "C" Dimensions | | | | | | | |
|---------------|----------------|------|---|-----|---|-----|---|---|
| | 3.50 | 4.38 | 5 | 5.5 | 7 | 7.5 | 8 | 9 |
| 150 | • | • | • | | | | | |
| 175 | • | • | • | • | | | | |
| 225 | • | • | • | • | • | | | |
| 300 | | | • | • | • | | | |
| 350 | | | • | • | • | | | |
| 375 | | | • | • | • | | | |
| 412 | | | | | • | | | |
| 462 | | | | | • | • | | |
| 512 | | | | | • | • | • | |
| 562 | | | | | | | • | |
| 600 | | | | | | | | • |

Engineering Data

| Coupling Size | Max Horsepower Per 100 RPM | Max. RPM | | Max. Continuous Torque (lb.-in.) | Peak Overload Torque (lb.-in.) | ② Weight (lb.) | Weight Change Per inch of "C" (lb.) | ⑤ WR ² (lb.-in. ²) | WR ² Change Per Inch of "C" (lb.-in. ²) | Axial Capacity (in.) |
|---------------|----------------------------|------------------|------------|----------------------------------|--------------------------------|----------------|-------------------------------------|---|--|----------------------|
| | Service Factor | Max. RPM | | | | | | | | |
| | | ① ⑥ Not Balanced | ① Balanced | | | | | | | |
| 150 | 1.48 | 9,000 | 20,800 | 930 | 1,860 | 6.7 | 0.10 | 10.6 | 0.03 | ±0.050 |
| 175 | 2.59 | 8,300 | 17,000 | 1,630 | 3,260 | 9.4 | 0.14 | 20.6 | 0.09 | ±0.070 |
| 225 | 4.86 | 7,700 | 16,000 | 3,060 | 6,120 | 14 | 0.19 | 42 | 0.25 | ±0.075 |
| 300 | 11.5 | 6,800 | 14,000 | 7,260 | 14,520 | 26 | 0.26 | 121 | 0.66 | ±0.085 |
| 350 | 21.3 | 6,200 | 13,500 | 13,400 | 26,800 | 43 | 0.42 | 259 | 1.18 | ±0.090 |
| 375 | 30.6 | 5,650 | 12,000 | 19,300 | 38,600 | 55 | 0.43 | 423 | 1.62 | ±0.095 |
| 412 | 35.7 | 5,350 | 11,000 | 22,500 | 45,000 | 71 | 0.60 | 615 | 2.90 | ±0.110 |
| 462 | 64.1 | 5,000 | 10,000 | 40,400 | 80,800 | 101 | 0.80 | 1,110 | 4.65 | ±0.120 |
| 512 | 87.3 | 4,700 | 9,200 | 55,000 | 110,000 | 135 | 1.04 | 1,830 | 7.43 | ±0.130 |
| 562 | 133 | 4,350 | 8,300 | 84,100 | 168,200 | 186 | 1.28 | 3,020 | 10.38 | ±0.145 |
| 600 | 145 | 4,150 | 7,800 | 91,700 | 183,400 | 228 | 1.75 | 4,250 | 17.51 | ±0.160 |

SPACER TYPE SERIES 71 – 8 BOLT

General Dimensions (inch)

| Coupling Size | ⑦ B & B ¹ Hub Max. Bore | ⑦ B ² Hub Max. Bore | A | ③ B | ④ B ¹ | Std. B ² | Std. C | Min. C | E | G |
|---------------|------------------------------------|--------------------------------|-------|------|------------------|---------------------|--------|--------|-------|-------|
| 225 | 3.000 | 3.750 | 5.97 | 2.50 | 3.12 | 3.06 | 5.00 | 4.75 | 4.19 | 4.56 |
| 262 | 3.438 | 4.188 | 6.88 | 3.06 | 3.69 | 3.56 | 7.00 | 5.50 | 4.69 | 5.19 |
| 312 | 4.188 | 5.125 | 8.00 | 3.56 | 4.31 | 4.12 | 7.50 | 6.00 | 5.75 | 6.31 |
| 350 | 4.688 | 5.562 | 8.94 | 3.88 | 4.75 | 4.50 | 7.50 | 6.75 | 6.50 | 7.06 |
| 375 | 5.250 | 6.500 | 9.94 | 4.44 | 5.31 | 5.16 | 7.50 | 7.25 | 7.13 | 7.94 |
| 425 | 5.625 | 6.750 | 10.75 | 4.88 | 5.88 | 5.50 | 8.00 | 7.50 | 7.44 | 8.44 |
| 450 | 6.188 | 7.500 | 11.56 | 5.06 | 6.19 | 6.00 | 9.00 | 8.75 | 8.38 | 9.28 |
| 500 | 7.000 | 8.750 | 13.12 | 5.94 | 7.06 | 6.75 | 11.00 | 10.25 | 9.13 | 10.50 |
| 550 | 7.625 | — | 14.69 | 6.56 | 7.81 | — | — | 11.50 | 10.00 | 11.50 |
| 600 | 8.812 | — | 16.38 | 7.19 | 8.44 | — | — | 12.50 | 11.75 | 13.22 |
| 700 | 9.750 | — | 18.56 | 8.31 | 9.69 | — | — | 14.50 | 12.78 | 14.69 |
| 750 | 10.812 | — | 20.12 | 8.94 | 10.31 | — | — | 15.75 | 14.31 | 16.25 |

Stocked "C" Dimensions

| Coupling Size | "C" Dimensions | | | | | | | |
|---------------|----------------|------|---|-----|---|-----|---|---|
| | 3.50 | 4.38 | 5 | 5.5 | 7 | 7.5 | 8 | 9 |
| 225 | | | | | | | | |
| 262 | | | • | • | • | | | |
| 312 | | | | • | • | • | | |
| 350 | | | | | • | • | • | |
| 375 | | | | | • | • | • | |
| 425 | | | | | | • | • | |
| 450 | | | | | | | | |
| 500 | | | | | | | | |
| 550 | | | | | | | | |
| 600 | | | | | | | | |
| 700 | | | | | | | | |
| 750 | | | | | | | | |

Engineering Data

| Coupling Size | Max Horsepower Per 100 RPM | Maximum RPM | | Max. Continuous Torque (lb.-in.) | Peak Overload Torque (lb.-in.) | ② Weight (lb.) | Weight Change Per inch of "C" (lb.) | ⑤ WR ² (lb.-in. ²) | WR ² Change Per Inch of "C" (lb.-in. ²) | Axial Capacity (in.) |
|---------------|----------------------------|------------------|------------|----------------------------------|--------------------------------|----------------|-------------------------------------|---|--|----------------------|
| | Service Factor | Maximum RPM | | | | | | | | |
| | | ① ⑥ Not Balanced | ① Balanced | | | | | | | |
| 225 | 27.77 | 7,500 | 14,000 | 17,500 | 35,000 | 27.8 | 0.38 | 128 | 1.07 | ±0.036 |
| 262 | 52.09 | 6,800 | 12,500 | 32,830 | 65,660 | 43 | 0.46 | 265 | 1.95 | ±0.043 |
| 312 | 81.55 | 6,200 | 11,500 | 51,400 | 102,800 | 67 | 0.55 | 580 | 3.34 | ±0.051 |
| 350 | 106 | 5,700 | 10,500 | 66,900 | 133,800 | 95 | 0.75 | 1,031 | 5.63 | ±0.056 |
| 375 | 159 | 5,200 | 9,800 | 100,300 | 200,600 | 134 | 1.05 | 1,784 | 9.23 | ±0.062 |
| 425 | 213 | 5,000 | 9,300 | 134,300 | 268,600 | 169 | 1.22 | 2,616 | 12.60 | ±0.067 |
| 450 | 239 | 4,700 | 8,700 | 150,400 | 300,800 | 220 | 1.59 | 4,020 | 18.00 | ±0.072 |
| 500 | 391 | 4,200 | 7,900 | 246,400 | 492,800 | 341 | 2.12 | 8,040 | 31.40 | ±0.082 |
| 550 | 524 | 3,900 | 7,300 | 330,400 | 660,800 | 475 | 2.65 | 13,930 | 49.80 | ±0.092 |
| 600 | 688 | 3,600 | 6,800 | 433,800 | 867,600 | 653 | 3.05 | 24,130 | 69.10 | ±0.102 |
| 700 | 1,071 | 3,300 | 6,200 | 674,800 | 1,349,600 | 961 | 4.13 | 44,900 | 118.00 | ±0.115 |
| 750 | 1,331 | 3,100 | 5,800 | 838,800 | 1,677,600 | 1,242 | 5.17 | 69,220 | 175.00 | ±0.125 |

For ordering instructions, see Pages 10-11.

- ① See page 7 for explanation of RPM limits and balancing recommendations.
- ② Weight and WR² with standard length hubs, maximum bore and standard "C".
- ③ Extended hub length is designed longer in order to include a counter-bore for the threaded extension on a tapered shaft.
- ④ Large hub length. For sizes not shown, consult Rexnord.
- ⑤ All Thomas disc couplings meet NEMA frame sleeve bearing motor specifications without modifications or the addition of end-float restricting devices.
- ⑥ Series 71 Coupling assembly meets AGMA Class 9 Balance when finish bored with interference fits.
- ⑦ Consult Rexnord for minimum rough bore sizes..
- ⑧ If a block hub is supplied, extra capscrews will be provided for center member jacking feature.

Note: Dimensions subject to change. Certified dimensions of ordered material furnished on request.

THOMAS® FLEXIBLE DISC COUPLINGS

SPACER TYPE DBZ-C

DBZ-C couplings use the same disc pack and materials as the DBZ. The center member is available in a variety of lengths and is recommended for ANSI and API process pumps. The "drop out" center member feature of this coupling allows for coupling maintenance and pump seal replacement with out disturbing the connected equipment.

Construction

Hubs and Center Assembly: Carbon Steel
 Bolts: Alloy Steel
 Disc Packs: Tomaloy
 Coatings Available: Black Oxide, Zinc, Cadmium

Other materials such as Stainless Steel, Monel and Inconel are available; please consult Rexnord Industries, Inc.

Misalignment: 1/2° per disc pack

Stocked "C" Dimensions

| Coupling Size | "C" Dimensions | | | | | | | | |
|---------------|----------------|---|------|------|---|-----|---|-----|---|
| | 3.5 | 4 | 4.38 | 4.75 | 5 | 5.5 | 7 | 7.5 | 8 |
| 101 | • | | | | | | | | |
| 126 | • | | • | | • | | | | |
| 163 | • | • | • | • | • | | • | | |
| 201 | • | | • | | • | • | • | | |
| 226 | | | • | | • | • | • | | |
| 263 | | | | | • | • | • | | |
| 301 | | | | | | • | • | | |
| 351 | | | | | | | | • | |
| 401 | | | | | | | | | • |



General Dimensions (inch)

| Cplg. Size | ②⑤ Max Bore | A | B | Std. C | Min. C | F | G | N |
|------------|-------------|-------|------|--------|--------|-------|------|------|
| 50 | 0.63 | 2.00 | 0.88 | 3.50 | — | 5.26 | 1.00 | 0.24 |
| 62 | 0.75 | 2.44 | 1.09 | 3.50 | — | 5.68 | 1.19 | 0.32 |
| 75 | 0.88 | 2.69 | 1.13 | 3.50 | — | 5.76 | 1.44 | 0.33 |
| 101 | 1.16 | 3.22 | 1.38 | 3.50 | — | 6.26 | 1.69 | 0.45 |
| 126 | 1.38 | 3.84 | 1.63 | 3.50 | 2.88 | 6.76 | 2.06 | 0.52 |
| 163 | 1.88 | 4.56 | 1.88 | 3.50 | 2.88 | 7.26 | 2.75 | 0.52 |
| 201 | 2.25 | 5.34 | 2.13 | 3.50 | 3.31 | 7.76 | 3.28 | 0.59 |
| 226 | 2.63 | 6.06 | 2.63 | 5.00 | 4.31 | 10.26 | 3.78 | 0.98 |
| 263 | 3.00 | 7.00 | 3.00 | 5.00 | 4.75 | 11.00 | 4.44 | 1.04 |
| 301 | 3.50 | 8.00 | 3.44 | 5.50 | 5.44 | 12.38 | 5.06 | 1.11 |
| 351 | 4.00 | 9.38 | 4.06 | 7.50 | 6.38 | 15.62 | 5.81 | 1.34 |
| 401 | 4.50 | 10.69 | 4.63 | 8.00 | 6.94 | 17.26 | 6.63 | 1.44 |
| 451 | 4.75 | 12.13 | 5.25 | 9.50 | 7.69 | 20.00 | 7.38 | 1.55 |

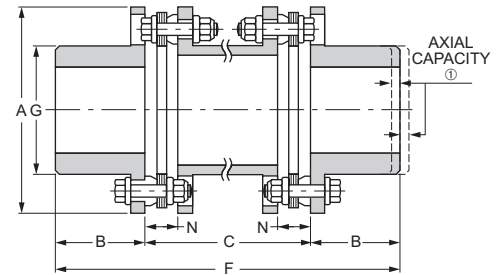

ALSO AVAILABLE WITH TAPERED-BORE HUBS

Engineering Data

| Coupling Size | Max Horsepower Per 100 RPM Service Factor | ③ Max. RPM | | Max. Continuous Torque (lb.-in.) | Peak Overload Torque (lb.-in.) | ② Weight (lb.) | Weight Change Per inch of "C" (lbs.) | ⑤ WR ² (lb.-in. ²) | WR ² Change Per Inch of "C" (lb.-in. ²) | Axial Capacity (in.) |
|---------------|--|--------------|----------|----------------------------------|--------------------------------|----------------|--------------------------------------|---|--|----------------------|
| | | Not Balanced | Balanced | | | | | | | |
| | | | | | | | | | | |
| 50 | 0.27 | 6,000 | 9,500 | 170 | 340 | 1.0 | 0.075 | 0.45 | 0.016 | ±0.023 |
| 62 | 0.46 | 6,000 | 8,600 | 290 | 580 | 1.8 | 0.091 | 1.4 | 0.027 | ±0.028 |
| 75 | 0.65 | 6,000 | 8,200 | 410 | 820 | 2.4 | 0.11 | 1.8 | 0.051 | ±0.032 |
| 101 | 1.30 | 6,000 | 7,500 | 820 | 1,640 | 4.6 | 0.28 | 6.0 | 0.16 | ±0.038 |
| 126 | 2.22 | 5,500 | 6,800 | 1,400 | 2,800 | 7.4 | 0.45 | 13.0 | 0.36 | ±0.046 |
| 163 | 3.09 | 5,000 | 6,300 | 1,950 | 3,900 | 10.8 | 0.43 | 27.4 | 0.70 | ±0.057 |
| 201 | 5.60 | 4,600 | 5,700 | 3,530 | 7,060 | 16.4 | 0.67 | 60.3 | 1.6 | ±0.067 |
| 226 | 10.0 | 4,100 | 5,500 | 6,300 | 12,600 | 24 | 0.78 | 104 | 2.4 | ±0.076 |
| 263 | 15.7 | 3,700 | 5,000 | 9,900 | 19,800 | 37 | 0.93 | 220 | 4.1 | ±0.089 |
| 301 | 23.5 | 3,300 | 4,700 | 14,800 | 29,600 | 54 | 1.20 | 425 | 6.9 | ±0.102 |
| 351 | 41.3 | 2,900 | 4,400 | 26,000 | 52,000 | 91 | 1.80 | 970 | 13 | ±0.118 |
| 401 | 60.3 | 2,700 | 4,100 | 38,000 | 76,000 | 135 | 2.70 | 1,860 | 26 | ±0.136 |
| 451 | 79.3 | 2,600 | 3,800 | 50,000 | 100,000 | 190 | 3.10 | 3,240 | 36 | ±0.154 |

For ordering instructions, see Page 10-11.

① All Thomas disc couplings meet NEMA frame sleeve bearing motor specifications without modification or the addition of end-float restricting devices.

② Popular sized bores with keyway and setscrew are stocked. Consult your Rexnord representative for stock bore size availability.

③ See page 7 for explanation of RPM limits and balancing recommendations.

④ Weight and WR² as shown are for maximum bores and standard. "C".

⑤ Consult Rexnord for minimum rough bore sizes.

THOMAS® FLEXIBLE DISC COUPLINGS

TYPE AMR

AMR couplings are used in heavy duty slow to medium speed applications, where high starting torque, shock loads, torque reversals or continuous alternating torque is present. The open lug type center member provides ample clearance for assembly while minimizing the space required for coupling installation.

Construction

Hubs: Cast Alloy Iron

Center Section: Sizes 162 – 750 are Cast Alloy Iron, Sizes 800 and above are Cast Steel

Bolts: Alloy Steel

Disc Packs: Tomaloy Tpack™ (225-750 Size)

Coatings Available: Black Oxide, Zinc, Cadmium

Other materials such as Stainless Steel, Monel and Inconel are available; please consult Rexnord Industries, Inc.

Misalignment: 1/8° per disc pack

****INCREASED TORQUE RATINGS****

General Dimensions (inch)

| Cplg. Size | ④ Rough Bore | ⑥ Max Bore | A | B | C | F | G |
|------------|--------------|------------|-------|-------|-------|-------|-------|
| 162 | — | 1.62 | 4.56 | 1.75 | 2.62 | 6.12 | 2.75 |
| 200 | — | 2.00 | 5.75 | 2.12 | 3.00 | 7.25 | 3.62 |
| 225 | — | 2.25 | 6.00 | 2.50 | 3.00 | 8.00 | 3.88 |
| 262 | — | 2.62 | 6.88 | 2.88 | 3.50 | 9.25 | 4.50 |
| 312 | — | 3.12 | 8.12 | 3.38 | 4.12 | 10.88 | 5.44 |
| 350 | — | 3.50 | 9.12 | 3.75 | 4.56 | 12.06 | 6.00 |
| 375 | — | 3.75 | 10.06 | 4.00 | 5.12 | 13.12 | 6.50 |
| 425 | — | 4.25 | 11.00 | 4.25 | 5.56 | 14.06 | 7.00 |
| 450 | — | 4.50 | 11.88 | 4.50 | 5.94 | 14.94 | 7.44 |
| 500 | 2.69 | 5.00 | 13.44 | 5.00 | 6.81 | 16.81 | 8.38 |
| 550 | 2.69 | 5.50 | 15.00 | 5.50 | 7.69 | 18.69 | 9.44 |
| 600 | 3.69 | 6.00 | 16.75 | 6.00 | 8.44 | 20.44 | 10.31 |
| 700 | 4.25 | 7.00 | 18.94 | 7.00 | 9.62 | 23.62 | 11.75 |
| 750 | 4.94 | 7.50 | 20.62 | 7.25 | 10.50 | 25.00 | 12.62 |
| 800 | 5.19 | 8.00 | 22.38 | 7.75 | 11.38 | 26.88 | 13.75 |
| 850 | 5.44 | 8.50 | 23.75 | 8.25 | 12.12 | 28.62 | 14.50 |
| 925 | 5.94 | 9.25 | 25.75 | 9.00 | 13.25 | 31.25 | 15.88 |
| 1000 | 6.50 | 10.00 | 28.25 | 9.50 | 14.50 | 33.50 | 17.50 |
| 1100 | 7.00 | 11.00 | 30.25 | 10.25 | 15.50 | 36.00 | 18.50 |
| 1200 | 7.50 | 12.00 | 33.38 | 11.00 | 17.06 | 39.06 | 20.25 |
| 1300 | 8.00 | 13.00 | 36.00 | 12.00 | 18.31 | 42.31 | 22.50 |
| 1550 | 8.50 | 15.50 | 39.25 | 14.50 | 19.44 | 48.44 | 26.00 |

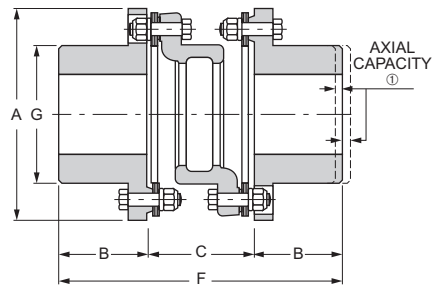
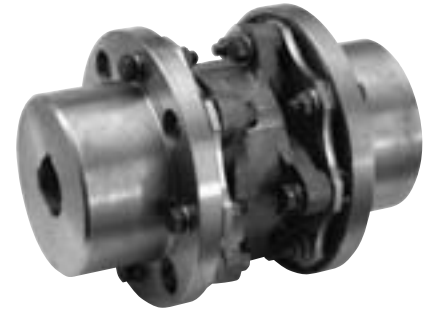

Engineering Data

| Coupling Size | Max Horsepower Per 100 RPM | ③ Max. RPM | Max. Continuous Torque (lb.-in.) | ⑦ Peak Overload Torque (lb.-in.) | ② Weight (lb.) | ⑤ WR ² (lb.-in. ²) | ① Axial Capacity (in.) |
|---------------|----------------------------|------------|----------------------------------|----------------------------------|----------------|---|------------------------|
| | Service Factor | | | | | | |
| 162 | 9.1 | 2,500 | 5,740 | 6,888 | 8 | 18 | ±0.036 |
| 200 | 17.5 | 2,500 | 11,030 | 13,236 | 16 | 57 | ±0.036 |
| 225 | 24.7 | 2,500 | 15,575 | 18,690 | 20 | 76 | ±0.036 |
| 262 | 33.4 | 2,500 | 21,038 | 25,245 | 32 | 162 | ±0.043 |
| 312 | 37.5 | 2,500 | 23,650 | 28,380 | 47 | 365 | ±0.051 |
| 350 | 83.8 | 2,300 | 52,800 | 63,360 | 71 | 659 | ±0.056 |
| 375 | 126 | 2,200 | 79,442 | 95,330 | 92 | 1,025 | ±0.062 |
| 425 | 140 | 2,000 | 88,000 | 105,600 | 117 | 1,590 | ±0.067 |
| 450 | 216 | 1,900 | 136,125 | 163,350 | 144 | 2,250 | ±0.072 |
| 500 | 319 | 1,800 | 200,750 | 240,900 | 212 | 4,240 | ±0.082 |
| 550 | 436 | 1,800 | 275,055 | 330,066 | 290 | 7,220 | ±0.092 |
| 600 | 569 | 1,800 | 358,875 | 430,650 | 389 | 12,000 | ±0.102 |
| 700 | 724 | 1,500 | 456,500 | 547,800 | 587 | 22,800 | ±0.115 |
| 750 | 1,023 | 1,500 | 644,930 | 773,916 | 722 | 33,900 | ±0.125 |
| 800 | 1,291 | 1,200 | 813,780 | 976,536 | 938 | 55,600 | ±0.136 |
| 850 | 1,426 | 1,100 | 898,700 | 1,078,440 | 1,150 | 75,600 | ±0.144 |
| 925 | 2,033 | 1,000 | 1,281,280 | 1,537,536 | 1,400 | 102,000 | ±0.156 |
| 1000 | 2,360 | 900 | 1,487,200 | 1,784,640 | 1,900 | 172,000 | ±0.172 |
| 1100 | 3,246 | 800 | 2,046,000 | 2,455,200 | 2,280 | 245,000 | ±0.183 |
| 1200 | 3,494 | 650 | 2,202,200 | 2,642,640 | 2,990 | 394,000 | ±0.203 |
| 1300 | 3,787 | 600 | 2,387,000 | 2,864,400 | 3,900 | 561,000 | ±0.218 |
| 1550 | 4,957 | 600 | 3,124,000 | 3,748,800 | 5,150 | 889,000 | ±0.242 |

For larger sizes, consult Rexnord. For ordering instructions, see Page 10-11.

① All Thomas disc couplings meet NEMA frame sleeve bearing motor specifications without modification or the addition of end-float restricting devices.

② Weight and WR² at maximum bore.

③ Consult Rexnord if balancing is required.

④ Consult Rexnord for minimum rough bore on sizes 162-450.

⑤ Special hub available for size 600 with 6 3/4 max. bore. Consult Rexnord.

⑥ Straight bores with no keyway require a steel hub. Consult Rexnord.

⑦ The Peak Overload Torque is not an alternating torque limit.

Note: Dimensions subject to change. Certified dimensions of ordered material furnished on request.

THOMAS® FLEXIBLE DISC COUPLINGS

FLYWHEEL ADAPTER TYPE CMR

CMR couplings are used in heavy duty slow to medium speed applications, where high starting torque, shock loads, torque reversals or continuous alternating torque is present. The open lug type center member provides ample clearance for assembly while minimizing the space required for coupling installation.

The CMR couplings are designed with a flywheel adapter plate which bolts directly to the flywheel of an engine or compressor. The adapters are made to fit accurately into the recess in the flywheel, and external strains on the crankshaft resulting from the misalignment of the driven equipment is minimized.

Construction

- Hubs: Cast Alloy Iron
- Center Section: Sizes 162 – 750 are Cast Alloy Iron, Sizes 800 and above are Cast Steel
- Bolts: Alloy Steel
- Disc Packs: Tomaloy Tpack™ (225-750 Size)
- Coatings Available: Black Oxide, Zinc, Cadmium

Other materials such as Stainless Steel, Monel and Inconel are available; please consult Rexnord Industries, Inc.

Misalignment: 1/8° per disc pack

****INCREASED TORQUE RATINGS****



CMR coupling between engine and reciprocating compressor.

FLYWHEEL ADAPTER INFORMATION

Adapters can be furnished to accommodate virtually any flange design. Where possible, the user should select dimensions from the tables below, as these represent industry standards and thus are the most economical selection. Note that most sizes are available either with SAE bolting or Thomas heavy duty bolting.

Available Adapters

| Coupling Size | Adapters Available in Shaded Sizes (inch) | | | | | | | | | | |
|-------------------|---|-------|--------|--------|--------|--------|--------|--------|--------|--------|--------|
| | 8.500 | 9.500 | 10.375 | 12.375 | 13.875 | 16.000 | 18.375 | 20.375 | 22.500 | 26.500 | 28.875 |
| Adapter Tolerance | 8.498 | 9.498 | 10.373 | 12.373 | 13.873 | 15.998 | 18.373 | 20.372 | 22.497 | 26.497 | 28.872 |
| 162 | | | | | | | | | | | |
| 200 | | | | | | | | | | | |
| 225 | | | | | | | | | | | |
| 262 | | | | | | | | | | | |
| 312 | | | | | | | | | | | |
| 350 | | | | | | | | | | | |
| 375 | | | | | | | | | | | |
| 425 | | | | | | | | | | | |
| 450 | | | | | | | | | | | |
| 500 | | | | | | | | | | | |
| 550 | | | | | | | | | | | |
| 600 | | | | | | | | | | | |
| 700 | | | | | | | | | | | |
| 750 | | | | | | | | | | | |
| 800 | | | | | | | | | | | |
| 850 | | | | | | | | | | | |

AVAILABLE IN THESE SIZES

Sizes 925 to 1550 – Adapting dimensions on request.

Bolting

| Standard A Diameter (in.) | Light Duty SAE Bolting | | | Heavy Duty Thomas Bolting | | |
|---------------------------|------------------------|-----------|-------------|---------------------------|-----------|-------------|
| | Bolt Circle | No. Holes | Size (Dia.) | Bolt Circle | No. Holes | Size (Dia.) |
| 8.5 | 7.88 | 6 | 0.34 | 7.5 | 8 | 0.41 |
| 9.5 | 8.75 | 8 | 0.34 | 8.62 | 8 | 0.47 |
| 10.38 | 9.62 | 6 | 0.41 | 9.5 | 8 | 0.47 |
| 12.38 | 11.62 | 8 | 0.41 | 11.5 | 8 | 0.53 |
| 13.88 | 13.12 | 8 | 0.41 | 12.5 | 8 | 0.66 |
| 16 | – | – | – | 14.38 | 8 | 0.078 |
| 18.38 | 17.25 | 8 | 0.53 | 16.75 | 8 | 0.078 |
| 20.38 | 19.25 | 8 | 0.53 | 18.5 | 8 | 0.091 |
| 22.5 | 21.38 | 6 | 0.66 | 20.5 | 8 | 1.03 |
| 26.5 | 25.25 | 12 | 0.66 | 24.5 | 12 | 1.03 |
| 28.88 | 27.25 | 12 | 0.78 | 26.88 | 12 | 1.03 |

Note: Dimensions subject to change. Certified dimensions of ordered material furnished on request.

THOMAS® FLEXIBLE DISC COUPLINGS

FLYWHEEL ADAPTER TYPE CMR

General Dimensions (inch)

| Coupling Size | ④ Rough Bore | ⑥ Max Bore | Min. A Dia. | B | C | D | E | F | G |
|---------------|--------------|------------|-------------|-------|-------|-------|------|-------|-------|
| 162 | — | 1.62 | 6.25 | 1.75 | 3.31 | 4.56 | 0.31 | 5.06 | 2.75 |
| 200 | — | 2.00 | 7.38 | 2.12 | 3.88 | 5.75 | 0.38 | 6.00 | 3.62 |
| 225 | — | 2.25 | 7.62 | 2.50 | 3.88 | 6.00 | 0.38 | 6.38 | 3.88 |
| 262 | — | 2.62 | 8.50 | 2.88 | 4.44 | 6.88 | 0.44 | 7.31 | 4.50 |
| 312 | — | 3.12 | 9.50 | 3.38 | 5.31 | 8.12 | 0.50 | 8.69 | 5.44 |
| 350 | — | 3.50 | 10.88 | 3.75 | 5.88 | 9.12 | 0.50 | 9.62 | 6.00 |
| 375 | — | 3.75 | 11.88 | 4.00 | 6.62 | 10.06 | 0.56 | 10.62 | 6.50 |
| 425 | — | 4.25 | 13.12 | 4.25 | 7.12 | 11.00 | 0.62 | 11.38 | 7.00 |
| 450 | — | 4.50 | 14.75 | 4.50 | 7.62 | 11.88 | 0.69 | 12.12 | 7.44 |
| 500 | 2.69 | 5.00 | 16.00 | 5.00 | 8.75 | 13.44 | 0.75 | 13.75 | 8.38 |
| 550 | 2.69 | 5.50 | 18.00 | 5.50 | 9.88 | 15.00 | 0.88 | 15.38 | 9.44 |
| 600 | 3.69 | 6.00 | 18.38 | 6.00 | 10.88 | 16.75 | 1.00 | 16.88 | 10.31 |
| 700 | 4.25 | 7.00 | 20.38 | 7.00 | 12.44 | 18.94 | 1.00 | 19.44 | 11.75 |
| 750 | 4.94 | 7.50 | 24.00 | 7.25 | 13.50 | 20.62 | 1.12 | 20.75 | 12.62 |
| 800 | 5.19 | 8.00 | 25.62 | 7.75 | 14.75 | 22.38 | 1.25 | 22.50 | 13.75 |
| 850 | 5.44 | 8.50 | 27.38 | 8.25 | 15.75 | 23.75 | 1.25 | 24.00 | 14.50 |
| 925 | 5.94 | 9.25 | 28.88 | 9.00 | 17.25 | 25.75 | 1.38 | 26.25 | 15.88 |
| 1000 | 6.50 | 10.00 | 31.62 | 9.50 | 18.56 | 28.25 | 1.62 | 28.06 | 17.50 |
| 1100 | 7.00 | 11.00 | 33.38 | 10.25 | 19.81 | 30.25 | 1.75 | 30.06 | 18.50 |
| 1200 | 7.50 | 12.00 | 37.50 | 11.00 | 21.56 | 33.88 | 2.00 | 32.56 | 20.25 |
| 1300 | 8.00 | 13.00 | 39.88 | 12.00 | 23.31 | 36.00 | 2.12 | 35.31 | 22.12 |
| 1550 | 8.50 | 15.50 | 43.62 | 14.50 | 23.75 | 39.25 | 2.12 | 38.25 | 26.00 |

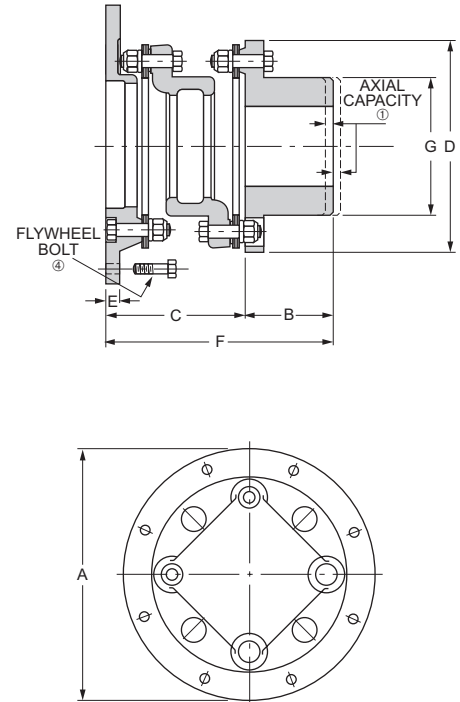

Engineering Data

| Coupling Size | Max Horsepower Per 100 RPM | ③ Max. RPM | Max. Continuous Torque (lb.-in.) | ⑦ Peak Overload Torque (lb.-in.) | ② Weight (lb.) | ⑤ WR ² (lb.-in. ²) | ① Axial Capacity (in.) |
|---------------|----------------------------|------------|----------------------------------|----------------------------------|----------------|---|------------------------|
| | Service Factor | | | | | | |
| 162 | 9.1 | 2,500 | 5,740 | 6,888 | 8 | 27 | ±0.036 |
| 200 | 17.5 | 2,500 | 11,030 | 13,236 | 12 | 68 | ±0.036 |
| 225 | 24.7 | 2,500 | 15,575 | 18,690 | 16 | 83 | ±0.036 |
| 262 | 33.4 | 2,500 | 21,038 | 25,245 | 25 | 178 | ±0.043 |
| 312 | 37.5 | 2,500 | 23,650 | 28,380 | 39 | 367 | ±0.051 |
| 350 | 83.8 | 2,300 | 52,800 | 63,360 | 56 | 630 | ±0.056 |
| 375 | 126 | 2,200 | 79,442 | 95,330 | 77 | 1,040 | ±0.062 |
| 425 | 140 | 2,200 | 88,000 | 105,600 | 101 | 1,780 | ±0.067 |
| 450 | 216 | 1,900 | 136,125 | 163,350 | 126 | 2,470 | ±0.072 |
| 500 | 319 | 1,800 | 200,750 | 240,900 | 178 | 4,310 | ±0.082 |
| 550 | 436 | 1,800 | 275,055 | 330,066 | 245 | 7,700 | ±0.092 |
| 600 | 569 | 1,800 | 358,875 | 430,650 | 321 | 11,500 | ±0.102 |
| 700 | 724 | 1,500 | 456,500 | 547,800 | 481 | 21,200 | ±0.115 |
| 750 | 1,023 | 1,500 | 644,930 | 773,916 | 610 | 34,300 | ±0.125 |
| 800 | 1,291 | 1,200 | 813,780 | 976,536 | 800 | 58,700 | ±0.136 |
| 850 | 1,426 | 1,100 | 898,700 | 1,078,440 | 975 | 73,300 | ±0.144 |
| 925 | 2,033 | 1,000 | 1,281,280 | 1,537,536 | 1,180 | 107,000 | ±0.156 |
| 1000 | 2,360 | 900 | 1,487,200 | 1,784,640 | 1,650 | 156,000 | ±0.172 |
| 1100 | 3,246 | 800 | 2,046,000 | 2,455,200 | 1,950 | 247,000 | ±0.183 |
| 1200 | 3,494 | 650 | 2,202,200 | 2,642,640 | 2,550 | 407,000 | ±0.203 |
| 1300 | 3,787 | 600 | 2,387,000 | 2,864,400 | 3,320 | 567,000 | ±0.218 |
| 1550 | 4,957 | 600 | 3,124,000 | 3,748,800 | 4,100 | 840,000 | ±0.242 |

For larger sizes, consult Rexnord. For ordering instructions, see pages 10-11.

- ① All Thomas disc couplings meet NEMA frame sleeve bearing motor specifications without modification or the addition of end-float restricting devices.
- ② Straight bores with no keyway require a steel hub. Consult Rexnord.
- ③ Maximum speeds are based on smallest available adapter O.D. For higher speeds, consult Rexnord.
- ④ Flywheel bolts are not supplied with coupling.
- ⑤ Weight and WR² at maximum bore and minimum adapter diameter.
- ⑥ Special hub available for size 600 with 6 3/4 max. bore. Consult Rexnord.
- ⑦ Consult Rexnord for minimum rough bore on sizes 162-450.
- ⑧ The Peak Overload Torque is not an alternating torque limit.

Note: Dimensions subject to change. Certified dimensions of ordered material furnished on request.

THOMAS® FLEXIBLE DISC COUPLINGS

TYPE BMR

Type BMR couplings are recommended for heavy duty motor and engine driven service such as paper machines, grinding mills, dredges, and marine propulsion.

The BMR uses a solid intermediate shaft which can be furnished complete by Rexnord or fabricated by the user. Hubs are cast alloy iron, shafting is hot or cold-rolled steel, and disc packs are Tomaloy Tpack (225-750 sizes) (stainless steel also available).

Misalignment: 1/8° per disc pack

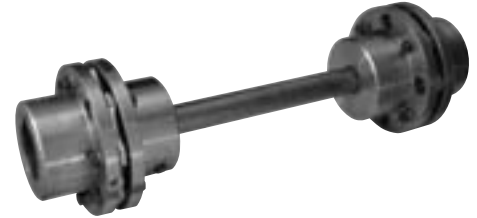

General Dimensions (inch)

| ④ Cplg. Size | ③ Rough Bore | Max Bore | A | B | C | F | G |
|--------------|--------------|----------|-------|------|------|-------|-------|
| 162 | — | 1.62 | 4.56 | 1.75 | 0.41 | 3.91 | 2.75 |
| 200 | — | 2.00 | 5.75 | 2.12 | 0.44 | 4.68 | 3.62 |
| 225 | — | 2.25 | 6.00 | 2.50 | 0.44 | 5.44 | 3.88 |
| 262 | — | 2.62 | 6.88 | 2.88 | 0.53 | 6.29 | 4.50 |
| 312 | — | 3.12 | 8.12 | 3.38 | 0.62 | 7.38 | 5.44 |
| 350 | — | 3.50 | 9.12 | 3.75 | 0.67 | 8.17 | 6.00 |
| 375 | — | 3.75 | 10.06 | 4.00 | 0.81 | 8.81 | 6.50 |
| 425 | — | 4.25 | 11.00 | 4.25 | 0.88 | 9.38 | 7.00 |
| 450 | — | 4.50 | 11.88 | 4.50 | 0.88 | 9.88 | 7.44 |
| 500 | 2.69 | 5.00 | 13.44 | 5.00 | 1.06 | 11.06 | 8.38 |
| 550 | 2.69 | 5.50 | 15.00 | 5.50 | 1.25 | 12.25 | 9.44 |
| 600 | 3.69 | 6.00 | 16.75 | 6.00 | 1.38 | 13.38 | 10.31 |

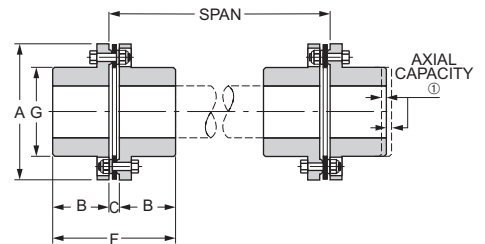

Engineering Data

| ④ Coupling Size | Max Horsepower Per 100 RPM | | Max. RPM | Max. Continuous Torque (lb.-in.) | Peak Overload Torque (lb.-in.) | ② Weight (lb.) | ② WR ² (lb.-in. ²) | ① Axial Capacity (in.) |
|-----------------|----------------------------|--|----------|----------------------------------|--------------------------------|----------------|---|------------------------|
| | Service Factor | | | | | | | |
| | 1 | | | | | | | |
| 162 | 9.1 | | 1,800 | 5,740 | 6,888 | 13 | 29 | ±0.036 |
| 200 | 17.5 | | 1,800 | 11,030 | 13,236 | 25 | 81 | ±0.036 |
| 225 | 24.7 | | 1,800 | 15,575 | 18,690 | 29 | 105 | ±0.036 |
| 262 | 33.4 | | 1,800 | 21,038 | 25,246 | 43 | 214 | ±0.043 |
| 312 | 37.5 | | 1,800 | 23,650 | 28,380 | 79 | 566 | ±0.051 |
| 350 | 84 | | 1,800 | 52,800 | 63,360 | 106 | 934 | ±0.056 |
| 375 | 126 | | 1,800 | 79,442 | 95,330 | 139 | 1,470 | ±0.062 |
| 425 | 140 | | 1,800 | 88,000 | 105,600 | 174 | 2,320 | ±0.067 |
| 450 | 216 | | 1,500 | 136,125 | 163,350 | 213 | 3,085 | ±0.072 |
| 500 | 319 | | 1,500 | 200,750 | 240,900 | 292 | 5,500 | ±0.082 |
| 550 | 436 | | 1,500 | 275,055 | 330,066 | 420 | 9,850 | ±0.092 |
| 600 | 569 | | 1,200 | 358,875 | 430,650 | 550 | 15,700 | ±0.102 |

BMR Shafting Selection Table

| ④ Cplg. Size | Shaft Dia. (in.) | Max HP/100 For Given Shaft Dia. | Max Allowable shaft Wt. (lb.) | Max Span (in.) at Max. Allow Shaft Wt. | Max. Span (in.) For Various RPM | | | |
|--------------|------------------|---------------------------------|-------------------------------|--|---------------------------------|------|-----|-----|
| | | | | | 1800 | 1200 | 900 | 720 |
| 162 | 1.62 | 6.9 | 60 | 102 | 54 | 66 | 76 | 85 |
| 200 | 2.00 | 13.5 | 74 | 83 | 60 | 73 | 83 | 83 |
| 225 | 2.25 | 19.0 | 86 | 76 | 64 | 76 | 76 | 76 |
| 262 | 2.50 | 24.3 | 178 | 128 | 67 | 82 | 95 | 106 |
| 312 | 2.88 | 34.1 | 233 | 127 | 72 | 88 | 102 | 114 |
| 350 | 3.50 | 76.2 | 290 | 107 | 79 | 97 | 107 | 107 |
| 375 | 3.75 | 99.7 | 412 | 132 | 82 | 100 | 116 | 130 |
| 425 | 4.25 | 127 | 502 | 125 | 87 | 107 | 123 | 125 |
| 450 | 4.50 | 157 | 596 | 132 | 90 | 110 | 127 | 132 |
| 500 | 5.00 | 232 | 804 | 145 | 95 | 116 | 134 | 145 |
| 550 | 5.50 | 300 | 1,027 | 153 | 99 | 122 | 140 | 153 |
| 600 | 6.00 | 414 | 1,296 | 162 | 104 | 127 | 147 | 162 |

For ordering instructions, see pages 10-11.

① All Thomas disc couplings meet NEMA frame sleeve bearing motor specifications without modifications or the addition of end-float restricting devices.

② Weight and WR² at maximum bore and minimum "L".

③ Consult Rexnord for minimum rough bore on sizes 162-450.

④ Consult Rexnord for larger sizes.

THOMAS® FLEXIBLE DISC COUPLINGS

TYPE SN-GA

Replaces troublesome gear couplings on pulp and paper applications. The Thomas one-piece, factory-torqued assembly is easy to install. This coupling is designed to bolt directly to existing rigid hubs using the gear coupling bolts. Axial shims are supplied for minor axial positioning adjustment.

Construction

Hubs and Center Assembly: Carbon Steel
 Bolts: Alloy Steel
 Disc Packs: Stainless Tpack™
 Coatings Available: Black Oxide, Zinc, Cadmium

Other materials such as Tomaloy, Stainless Steel, Monel and Inconel are available; please consult Rexnord Industries, Inc.

Misalignment: 1/3° per disc pack

Available Adapters

| Gear Coupling (Falk) Thomas Coupling | #1 1/2 (1015) | #2 (1020) | #2 1/2 (1025) | #3 (1030) | #3 1/2 (1035) | #4 (1040) | #4 1/2 (1045) | #5 (1050) | #5 1/2 (1055) | #6 (1060) | #7 (1070) |
|--------------------------------------|---------------|-----------|---------------|-----------|---------------|-----------|---------------|-----------|---------------|-----------|-----------|
| 226 | | | | | | | | | | | |
| 262 | | | | | | | | | | | |
| 312 | | | | | | | | | | | |
| 350 | | | | | | | | | | | |
| 375 | | | | | | | | | | | |
| 425 | | | | | | | | | | | |
| 450 | | | | | | | | | | | |
| 500T | | | | | | | | | | | |
| 550T | | | | | | | | | | | |
| 600T | | | | | | | | | | | |
| 700T | | | | | | | | | | | |
| 750T | | | | | | | | | | | |
| 800T | | | | | | | | | | | |
| 850T | | | | | | | | | | | |

Other sizes available – consult Rexnord.

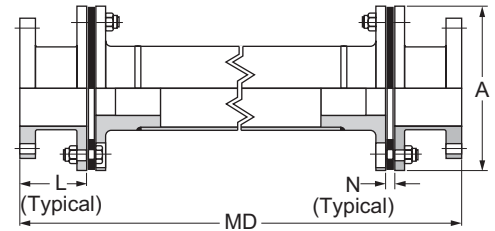

Engineering Data

| Coupling Size | Max Horsepower Per 100 RPM | Max. Continuous Torque (lb.-in.) | Peak Overload Torque (lb.-in.) ^② | A | L | Min. MD (3) | N | Axial Capacity (in.) ^① |
|------------------|----------------------------|----------------------------------|---|-------|-------|-------------|------|-----------------------------------|
| | Service Factor | | | | | | | |
| 226 | 1.0 | 14,260 | 28,520 | 5.81 | 4.00 | 16.25 | 0.58 | 0.036 |
| 262 | 22.6 | 22,000 | 44,000 | 6.69 | 4.50 | 17.25 | 0.47 | 0.043 |
| 312 | 34.9 | 28,200 | 56,400 | 7.81 | 5.12 | 20.00 | 0.50 | 0.051 |
| 350 | 44.7 | 35,100 | 70,200 | 8.75 | 5.31 | 22.12 | 0.54 | 0.056 |
| 375 | 55.7 | 77,300 | 154,600 | 9.69 | 6.62 | 26.00 | 0.59 | 0.062 |
| 425 | 123 | 117,850 | 235,700 | 10.50 | 6.50 | 26.25 | 0.62 | 0.067 |
| 450 ^③ | 187 | 136,000 | 272,000 | 11.31 | 6.75 | 28.50 | 0.78 | 0.072 |
| 500T | 216 | 232,400 | 464,800 | 12.88 | 7.25 | 30.00 | 0.78 | 0.082 |
| 550T | 369 | 269,200 | 538,400 | 14.44 | 7.75 | 33.50 | 0.91 | 0.092 |
| 600T | 427 | 411,000 | 822,000 | 16.00 | 9.12 | 36.74 | 0.98 | 0.102 |
| 700T | 652 | 549,000 | 1,098,000 | 18.25 | 9.25 | 40.50 | 1.20 | 0.115 |
| 750T | 871 | 631,000 | 1,262,000 | 19.81 | 9.75 | 43.00 | 1.27 | 0.125 |
| 800T | 1,001 | 908,000 | 1,816,000 | 21.50 | 10.25 | – | 1.34 | 0.136 |
| 850T | 1,441 | 1,107,000 | 2,214,000 | 23.00 | 10.25 | – | 1.40 | 0.144 |

For larger sizes, consult Rexnord. For ordering instructions, see Page 10-11.

① All Thomas disc couplings meet NEMA frame sleeve bearing motor specifications without modification or the addition of end-float restricting devices.

② The Peak Overload Torque is not an alternating torque limit.

③ Available with Tpack for new couplings, not retrofittable in size 450.

Note: Dimensions subject to change. Certified dimensions of ordered material furnished on request.

THOMAS® FLEXIBLE DISC COUPLINGS

FLOATING SHAFT TYPES SN, SF, SV

Floating shaft couplings are used to connect units which are relatively far apart. Such arrangements are particularly suited to transmit power into areas where moisture, dust or corrosive conditions would adversely affect the driving machinery.

Floating shaft couplings' operating speeds are dependent upon the length of span required. Refer to the speed/span table for speed recommendations. In addition, special balancing may be required for high speed service or for extended shaft lengths. Consult Rexnord Industries, Inc. for intended applications at speeds not covered in the table.

The SN, SF and SV type couplings are furnished with stainless steel disc packs unless otherwise specified.

TYPE SN

Full-Floating Shaft Coupling

Type SN couplings use a tubular center shaft, fabricated complete by Rexnord. Typical applications include cooling tower fan drives, paper machinery, printing presses, pumps and compressors.

Connected shafts should be rigidly supported and long shaft overhang should be avoided. The tubular coupling shaft **MUST NOT** be supported with a bearing. They may be operated vertically if length does not exceed 36 inches.



TYPE SF

Semi-Floating Shaft Coupling

Type SF couplings are a tubular shaft design with a stub shaft and bearing journal replacing the half-coupling on one end. They are typically used in tandem with the Type SN or Type SV where spans are too long for a single section of shafting.



TYPE SV

Vertical Floating Shaft Couplings

Type SV couplings are similar to the Type SN except that the lower half-coupling is modified to support the weight of the floating shaft. Typical applications include fresh-water pumps, sewage pumps, and marine cargo pumps. They may be used in tandem with the Type SF where spans are too long for a single shaft.



Corrosion Resistant Materials

Types SN, SV and SF couplings are particularly suited to applications involving wet or corrosive conditions, for this reason they are all furnished with 300 series stainless steel disc packs. For extremely corrosive environments 316 stainless steel, Inconel 625 or Monel disc pack materials are available on request. As standard, these couplings are available in the following material classes.

CLASS

- A – All steel
- B – All Steel – zinc plated
- C – All Steel – zinc plated w/stainless steel hardware
- D – Stainless steel except for zinc plated hubs
- E – All 300 series stainless steel

Note:

1. The stub shaft on the SF coupling is always furnished as unplated carbon steel in classes A, B, C and D.
2. Couplings may be painted with acid and alkali resistant paints or coating besides the corrosion resistant classes listed.

Floating Shaft Couplings

Types SN, SV and SF center members are of tubular construction, requiring special considerations for the operating speed and span length. The graph to the right may be used as a guide when determining whether it is desirable to balance the center member.

The standard procedure for balancing of SN, SV and SF couplings includes straightening of the tubular shaft prior to balancing. Many couplings of this type operate relatively near to the lateral resonant frequency of the coupling center member, and special balancing techniques are often required.

Consult Rexnord Industries, Inc. for any application with speed in excess of 1800 RPM.

Engineering Data
Maximum Span (L) in Inches for Various Speeds - For SN & SV^①
Maximum Span (X) in Inches for Various Speeds for SF^①

| Coupling Size | ③ 3600 RPM | 3600 RPM | ② 1800 RPM | 1500 RPM | 1200 RPM | 1000 RPM | 900 RPM | 750 RPM | 720 RPM | 600 RPM | 500 RPM |
|------------------|----------------|----------------|------------|----------|----------|----------|---------|---------|---------|----------------|----------------|
| 50 | See Footnote ③ | See Footnote ③ | 43 | 47 | 52 | 56 | 56 | 56 | 56 | 56 | 56 |
| 62 | See Footnote ③ | See Footnote ③ | 50 | 54 | 61 | 67 | 70 | 75 | 75 | 75 | 75 |
| 75 | ③ | ③ | 56 | 61 | 68 | 75 | 79 | 86 | 88 | 94 | 94 |
| 100 | 41 | 45 | 57 | 64 | 71 | 78 | 82 | 91 | 93 | 102 | 102 |
| 125 | 47 | 51 | 64 | 72 | 81 | 88 | 93 | 103 | 105 | 114 | 114 |
| 162 | 54 | 59 | 75 | 84 | 94 | 103 | 109 | 119 | 122 | 133 | 133 |
| 200 | 60 | 66 | 85 | 93 | 104 | 114 | 120 | 132 | 135 | 147 | 161 |
| 226 | 64 | 70 | 90 | 99 | 112 | 122 | 128 | 141 | 144 | 157 | 172 |
| 262 | 71 | 77 | 100 | 110 | 123 | 135 | 142 | 156 | 160 | 173 | 191 |
| 312 | 75 | 82 | 107 | 117 | 130 | 143 | 151 | 165 | 173 | 185 | 203 |
| 350 | 79 | 87 | 113 | 123 | 138 | 151 | 159 | 174 | 178 | 195 | 213 |
| 375 | 87 | 95 | 123 | 135 | 151 | 165 | 174 | 191 | 195 | 213 | 234 |
| 425 | 90 | 99 | 128 | 141 | 157 | 172 | 182 | 199 | 203 | 222 | 244 |
| 450 ^③ | 90 | 99 | 128 | 141 | 157 | 172 | 182 | 199 | 203 | 222 | 244 |
| 500 | 104 | 113 | 147 | 161 | 180 | 197 | 207 | 227 | 232 | 254 | 279 |
| 550T | See Footnote ③ | See Footnote ③ | 147 | 161 | 180 | 197 | 207 | 227 | 232 | 254 | 279 |
| 600T | See Footnote ③ | See Footnote ③ | 165 | 180 | 202 | 221 | 233 | 255 | 260 | 285 | 312 |
| 700T | ③ | ③ | 164 | 179 | 200 | 219 | 231 | 253 | 258 | 283 | 310 |
| 750T | See Footnote ③ | See Footnote ③ | 164 | 179 | 200 | 219 | 231 | 253 | 258 | 283 | 310 |
| 800T | See Footnote ③ | See Footnote ③ | 179 | 196 | 219 | 240 | 252 | 276 | 282 | 309 | See Footnote ③ |
| 850T | ③ | ③ | 187 | 205 | 229 | 251 | 265 | 290 | 296 | See Footnote ③ | See Footnote ③ |
| 925T | ③ | ③ | 200 | 220 | 245 | 269 | 284 | 311 | 317 | Footnote ③ | ③ |

- ① Do not use floating shaft couplings on equipment having long overhung shafts.
- ② Speeds 1800 rpm and under see page 12 for balancing recommendations. Consult Rexnord on speeds in excess of 1800 rpm. Advise operating speed when ordering.
- ③ For spans not shown, consult Rexnord with application data for "span/speed" review. Consult Rexnord for speeds in excess of 3600 rpm. Advise speed when ordering.

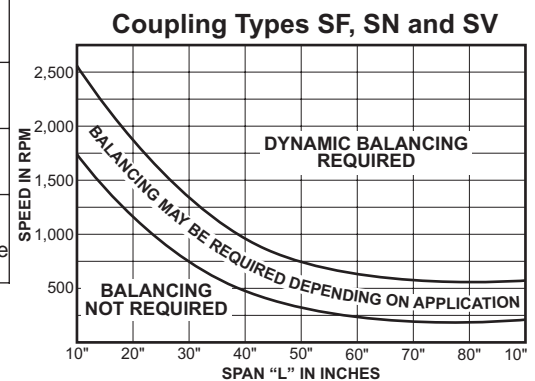

THOMAS® FLOATING SHAFT COUPLING

TYPES SN, SF, SV

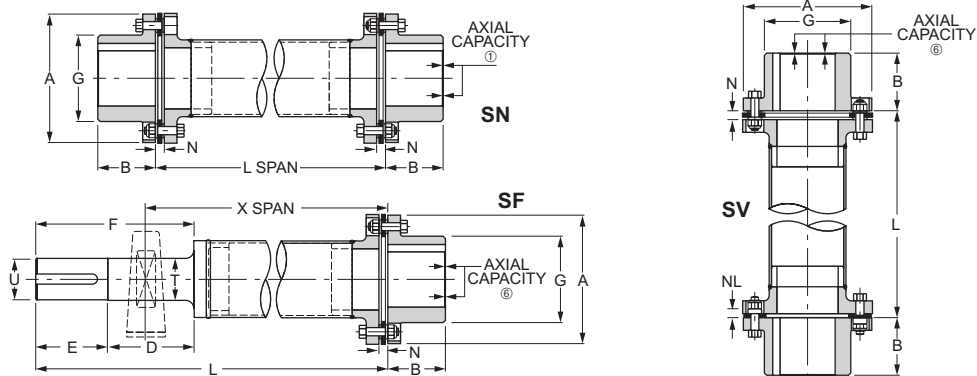

General Dimensions (inch)

| ⑤ Coupling Size | Coupling Size | | | Max. Bore | A | B | D | E | ③ T | ③ U | F | G | N | NL | ② Min. L | |
|-----------------|---------------|----|----|-----------|-------|------|------|------|------|------|-------|-------|------|------|----------|-------|
| | SN | SV | SF | | | | | | | | | | | | SN | SF |
| 50 | • | | | 0.63 | 2.00 | 0.88 | — | — | — | — | — | 1.00 | 0.24 | — | 4.00 | — |
| 62 | • | | | 0.75 | 2.44 | 1.09 | — | — | — | — | — | 1.19 | 0.32 | — | 4.50 | — |
| 75 | • | | | 0.88 | 2.69 | 1.13 | — | — | — | — | — | 1.44 | 0.33 | — | 4.75 | — |
| 100 | • | • | • | 1.16 | 3.22 | 1.38 | 3.75 | 1.75 | 0.94 | 0.88 | 5.50 | 1.69 | 0.45 | 0.13 | 5.75 | 12.00 |
| 125 | • | • | • | 1.38 | 3.84 | 1.63 | 4.25 | 2.13 | 1.19 | 1.13 | 6.38 | 2.06 | 0.52 | 0.15 | 6.25 | 12.25 |
| 162 | • | • | • | 1.88 | 4.47 | 1.88 | 4.50 | 2.63 | 1.44 | 1.38 | 7.13 | 2.75 | 0.54 | 0.16 | 6.75 | 13.25 |
| 200 | • | • | • | 2.25 | 5.44 | 2.13 | 5.50 | 2.88 | 1.69 | 1.63 | 8.38 | 3.28 | 0.57 | 0.16 | 7.50 | 15.50 |
| 226® | • | • | • | 2.63 | 5.81 | 2.63 | 5.63 | 3.38 | 1.94 | 1.88 | 9.00 | 3.78 | 0.58 | 0.18 | 8.25 | 16.50 |
| 262 | • | • | • | 3.13 | 6.69 | 3.00 | 6.13 | 3.75 | 2.19 | 2.13 | 9.88 | 4.50 | 0.47 | 0.22 | 8.25 | 18.00 |
| 312 | • | • | • | 3.63 | 7.81 | 3.38 | 6.38 | 4.00 | 2.44 | 2.38 | 10.38 | 5.25 | 0.50 | 0.25 | 9.75 | 19.50 |
| 350 | • | • | • | 4.00 | 8.75 | 3.75 | 7.50 | 4.50 | 2.94 | 2.88 | 12.00 | 5.88 | 0.54 | 0.29 | 11.50 | 20.50 |
| 375 | • | • | • | 4.50 | 9.69 | 4.00 | 8.00 | 4.75 | 3.44 | 3.38 | 12.75 | 6.50 | 0.59 | 0.33 | 12.75 | 23.25 |
| 425 | • | • | • | 4.75 | 10.50 | 4.25 | 9.00 | 5.00 | 3.69 | 3.63 | 14.00 | 7.00 | 0.62 | 0.37 | 13.25 | 25.25 |
| 450® | • | • | • | 5.13 | 11.31 | 4.50 | — | — | — | — | — | 7.44 | 0.78 | 0.40 | 15.00 | — |
| 500T | • | • | • | 5.38 | 12.88 | 5.00 | — | — | — | — | — | 8.38 | 0.78 | 0.47 | 15.50 | — |
| 550T | • | • | • | 6.00 | 14.44 | 5.50 | — | — | — | — | — | 9.44 | 0.91 | 0.53 | 18.00 | — |
| 600T | • | • | • | 6.50 | 16.00 | 6.00 | — | — | — | — | — | 10.25 | 0.98 | 0.60 | 18.50 | — |
| 700T | • | • | • | 7.50 | 18.25 | 7.00 | — | — | — | — | — | 11.75 | 1.20 | 0.70 | 22.00 | — |
| 750T | • | • | • | 8.00 | 19.81 | 7.50 | — | — | — | — | — | 12.63 | 1.27 | 0.77 | 23.50 | — |
| 800T | • | • | • | 8.75 | 21.50 | 8.25 | — | — | — | — | — | 13.62 | 1.34 | 0.84 | 26.00 | — |
| 850T | • | • | • | 9.25 | 23.00 | 8.75 | — | — | — | — | — | 14.50 | 1.40 | 0.90 | 36.00 | — |
| 925T | • | • | • | 10.12 | 25.00 | 9.50 | — | — | — | — | — | 15.75 | 1.50 | 1.00 | 36.00 | — |

Engineering Data

| ⑤ Coupling Size | Max. Continuous Torque (lb.-in.) | Peak Overload Torque (lb.-in.) | Weight (lb.) ④ | | Weight Change Per Inch of "L" (lb.) | ④ WR ² (lb.-in. ²) | | WR ² Change Per Inch of "L" (lb.-in. ²) | ① ⑥ Type SN Axial Capacity (in.) |
|-----------------|----------------------------------|--------------------------------|----------------|------|-------------------------------------|---|-----|--|----------------------------------|
| | | | SN, SV | SF | | SN, SV | SF | | |
| 50 | 170 | 340 | 1.1 | — | 0.022 | 0.5 | — | 0.0026 | ±0.023 |
| 62 | 290 | 580 | 1.6 | — | 0.030 | 1.2 | — | 0.0063 | ±0.028 |
| 75 | 410 | 820 | 2.4 | — | 0.052 | 1.9 | — | 0.018 | ±0.032 |
| 100 | 820 | 1,640 | 4.9 | 3.6 | 0.076 | 5.3 | 3.1 | 0.033 | ±0.038 |
| 125 | 2,230 | 4,460 | 7.5 | 6.5 | 0.095 | 12.2 | 7.1 | 0.068 | ±0.046 |
| 162 | 4,250 | 8,500 | 11 | 10.5 | 0.130 | 27 | 15 | 0.22 | ±0.036 |
| 200 | 8,600 | 17,200 | 21 | 11 | 0.290 | 32 | 17 | 0.56 | ±0.036 |
| 226 | 14,260 | 28,520 | 26.6 | 25 | 0.330 | 105 | 61 | 0.82 | ±0.036 |
| 262 | 22,000 | 44,000 | 38.6 | 36 | 0.410 | 218 | 133 | 1.6 | ±0.043 |
| 312 | 28,200 | 56,400 | 60.7 | 54 | 0.470 | 456 | 291 | 2.2 | ±0.051 |
| 350 | 35,100 | 70,200 | 85.5 | 78 | 0.520 | 807 | 478 | 3.1 | ±0.056 |
| 375 | 77,300 | 154,600 | 127 | 110 | 0.970 | 1,421 | 844 | 7.3 | ±0.062 |
| 425 | 117,850 | 235,700 | 173 | — | 1.58 | 2,448 | — | 15.9 | ±0.067 |
| 450® | 136,000 | 272,000 | 206 | — | 1.58 | 3,350 | — | 15.9 | ±0.072 |
| 500T | 232,400 | 464,800 | 239 | — | 2.38 | 4,955 | — | 41.1 | ±0.082 |
| 550T | 269,200 | 538,400 | 337 | — | 2.38 | 8,400 | — | 41.1 | ±0.092 |
| 600T | 411,000 | 822,000 | 442 | — | 3.37 | 14,510 | — | 91 | ±0.102 |
| 700T | 549,000 | 1,098,000 | 717 | — | 4.56 | 27,970 | — | 120 | ±0.115 |
| 750T | 631,000 | 1,262,000 | 882 | — | 4.56 | 40,270 | — | 120 | ±0.125 |
| 800T | 908,000 | 1,816,000 | 1,140 | — | 5.45 | 64,170 | — | 205 | ±0.136 |
| 850T | 1,107,000 | 2,214,000 | 1,420 | — | 6.00 | 91,730 | — | 274 | ±0.144 |
| 925T | 1,466,000 | 2,932,000 | 1,820 | — | 6.89 | 143,500 | — | 414 | ±0.156 |

For larger sizes and longer spans, consult Rexnord. For ordering instructions, see pages 10-11.

① All Thomas disc couplings meet NEMA frame sleeve bearing motor specifications without modification or the addition of end-float restricting devices.

② Shorter "L" requires special construction. Consult Rexnord.

③ Shaft tolerances: 5/16 to 1 1/2 +.000 - .0005, 1 5/8 to 3 11/16 .000 - .001. Key furnished with standard keyway in SF stub shaft.

④ Weight and WR² at max. bore and min. "L" dimension.

⑤ T suffix to coupling size indicates thin flange design. Consult Rexnord for larger sizes.

⑥ Types SF and SV end-float is one half ± value shown for type SN.

⑦ Consult Rexnord for minimum rough bore sizes.

⑧ Not available with Tpack

Note: Dimensions subject to change. Certified dimensions of ordered material furnished on request.

THOMAS® SINGLE-FLEXING DISC COUPLINGS

TYPE ST

ST couplings are designed for applications which require the coupling to support a substantial radial load while accommodating angular misalignment. Typical installations include units where one shaft is fully supported in its own bearings, and the other shaft is single-bearing supported. The radial load is transmitted through the coupling to the inner bearing of the other shaft.

Belt drives can be designed to utilize this type of coupling to eliminate a jack shaft bearing and transfer radial loading directly to a machine bearing. Such arrangements are economical and space saving. See the sketches below.

Construction

Hubs: Cast Alloy Iron

Bolts: Alloy Steel

Disc Packs: Tomaloy Tpack™ (225-750 Sizes)

Coatings Available: Black Oxide, Zinc, Cadmium

Other materials such as Stainless Steel, Monel and Inconel are available; please consult Rexnord Industries, Inc.



Note:

Single-flexing couplings cannot accommodate parallel misalignment. They are not suitable for connecting equipment where both shafts are held rigidly in their own bearings.

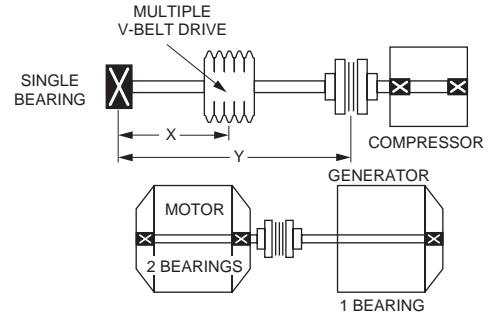

General Dimensions (inch)

| Coupling Size | ⑦ Rough Bore | Max Bore | A | B | F | G | N |
|---------------|--------------|----------|-------|------|-------|-------|------|
| 162 | — | 1.62 | 4.59 | 1.75 | 3.91 | 2.75 | 0.41 |
| 200 | — | 2.00 | 5.75 | 2.12 | 4.69 | 3.62 | 0.44 |
| 225 | — | 2.25 | 6.00 | 2.50 | 5.44 | 3.88 | 0.44 |
| 262 | — | 2.62 | 6.88 | 2.88 | 6.28 | 4.50 | 0.53 |
| 312 | — | 3.12 | 8.12 | 3.38 | 7.38 | 5.44 | 0.62 |
| 350 | — | 3.50 | 9.12 | 3.75 | 8.19 | 6.00 | 0.69 |
| 375 | — | 3.75 | 10.06 | 4.00 | 8.88 | 6.50 | 0.88 |
| 425 | — | 4.25 | 11.00 | 4.25 | 9.38 | 7.00 | 0.88 |
| 450 | — | 4.50 | 11.88 | 4.50 | 9.94 | 7.44 | 0.94 |
| 500 | 2.69 | 5.00 | 13.44 | 5.00 | 11.12 | 8.38 | 1.12 |
| 550 | 2.69 | 5.50 | 15.00 | 5.50 | 12.31 | 9.44 | 1.31 |
| 600 | 3.69 | 6.00 | 16.75 | 6.00 | 13.38 | 10.31 | 1.38 |
| 700 | 4.25 | 7.00 | 18.94 | 7.00 | 15.62 | 11.75 | 1.62 |
| 750 | 4.94 | 7.50 | 20.62 | 7.25 | 16.31 | 12.62 | 1.81 |
| 800 | 5.19 | 8.00 | 22.38 | 7.75 | 17.38 | 13.75 | 1.88 |

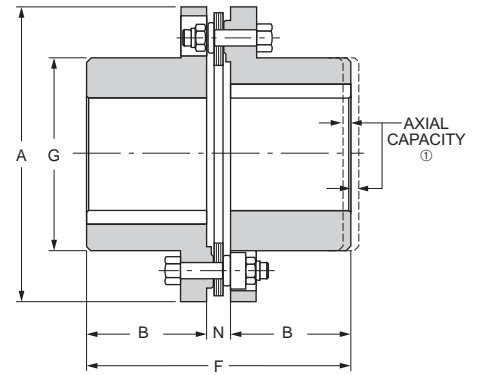

Engineering Data

| Coupling Size | Max. Radial Load (lb.) | Max Horsepower Per 100 RPM | | | | | | Max. RPM | ⑥ Max. Continuous Torque (lb.-in.) | ⑥ Peak Overload Torque (lb.-in.) | ② Weight (lb.) | ② WR ² (lb.-in. ²) | ① Axial Capacity (in.) |
|---------------|------------------------|----------------------------|----------|----------|-----------|----------|----------|----------|------------------------------------|----------------------------------|----------------|---|------------------------|
| | | Smooth | | | Pulsating | | | | | | | | |
| | | ③ Col. 1 | ④ Col. 2 | ⑤ Col. 3 | ③ Col. 4 | ④ Col. 5 | ⑤ Col. 6 | | | | | | |
| 162 | 150 | 0.8 | 1.1 | 1.4 | 0.4 | 0.6 | 0.7 | 2,500 | 880 | 1,320 | 7 | 16 | ±0.018 |
| 200 | 225 | 1.5 | 2.1 | 2.7 | 0.7 | 1.0 | 1.3 | 2,500 | 1,700 | 2,550 | 14 | 46 | ±0.018 |
| 225 | 340 | 2.1 | 3.0 | 3.8 | 1.0 | 1.5 | 1.9 | 2,500 | 2,400 | 3,600 | 15 | 59 | ±0.018 |
| 262 | 520 | 3.8 | 5.3 | 6.8 | 1.9 | 2.6 | 3.4 | 2,500 | 4,280 | 6,420 | 23 | 120 | ±0.022 |
| 312 | 700 | 6.0 | 8.4 | 10.7 | 3.0 | 4.2 | 5.4 | 2,500 | 6,740 | 10,100 | 41 | 310 | ±0.026 |
| 350 | 900 | 8.5 | 11.9 | 15.3 | 4.2 | 6.0 | 7.6 | 2,300 | 9,640 | 14,500 | 56 | 520 | ±0.028 |
| 375 | 1,250 | 13.1 | 18.3 | 23.6 | 6.6 | 9.2 | 11.8 | 2,200 | 14,900 | 22,400 | 71 | 820 | ±0.031 |
| 425 | 1,500 | 17.0 | 23.8 | 30.6 | 8.5 | 11.9 | 16.3 | 1,900 | 19,300 | 29,000 | 93 | 1,300 | ±0.034 |
| 450 | 1,800 | 21.7 | 30.4 | 39.0 | 10.8 | 15.2 | 19.5 | 1,500 | 24,600 | 36,900 | 110 | 1,700 | ±0.036 |
| 500 | 2,400 | 33.5 | 46.9 | 60.3 | 16.8 | 23.4 | 30.2 | 1,500 | 38,000 | 57,000 | 160 | 3,100 | ±0.041 |
| 550 | 3,200 | 48.9 | 68.4 | 87 | 24.4 | 34.2 | 43.5 | 1,500 | 54,800 | 82,200 | 230 | 5,600 | ±0.046 |
| 600 | 4,000 | 68.6 | 96 | 123 | 34.3 | 48.0 | 61.5 | 1,200 | 77,500 | 116,000 | 300 | 8,400 | ±0.051 |
| 700 | 5,500 | 106 | 148 | 190 | 53.0 | 74.0 | 95.0 | 1,100 | 120,000 | 180,000 | 440 | 18,000 | ±0.058 |
| 750 | 6,500 | 139 | 194 | 250 | 69.5 | 97.0 | 125 | 1,000 | 158,000 | 237,000 | 590 | 27,000 | ±0.062 |
| 800 | 7,700 | 177 | 247 | 318 | 88.5 | 124 | 159 | 900 | 200,000 | 300,000 | 700 | 39,000 | ±0.068 |

For ordering instructions, see pages 10-11.

- ① All Thomas disc couplings meet NEMA frame sleeve bearing motor specifications without modification or the addition of end-float restricting devices.
- ② Weight and WR² at maximum bore.
- ③ Col. 1 gives maximum HP/100 RPM permitted when combined with maximum radial load.
- ④ Col. 2 gives maximum HP/100 RPM permitted when combined with 2/3 maximum radial load.
- ⑤ Col. 3 gives maximum HP/100 RPM permitted when combined with 1/3 maximum radial load.
- ⑥ Maximum torque and peak overload torque are based on 1/3 maximum radial load.
- ⑦ Consult Rexnord for minimum rough bore on sizes 162-450.

THOMAS® SINGLE-FLEXING DISC COUPLINGS

TYPE BMR SINGLE

BMR single couplings are used for single flex applications for light to moderate load. BMR is also available in a double flexing design.

Construction

Hubs: Cast Alloy Iron
 Center Section: Sizes 162 – 750 are Cast Alloy Iron, Sizes 800 and above are Cast Steel
 Bolts: Alloy Steel
 Disc Packs: Stainless Tpack™ (225-750 Sizes)
 Coatings Available: Black Oxide, Zinc, Cadmium

Other materials such as Stainless Steel, Monel and Inconel are available; please consult Rexnord Industries, Inc.

Misalignment: 1/8° per disc pack

Note:

Single-flexing couplings cannot accommodate parallel misalignment. They are not suitable for connecting equipment where both shafts are held rigidly in their own bearings.

General Dimensions (inch)

| Coupling Size | ① Rough Bore | Max Bore | A | B | F | G | N |
|---------------|--------------|----------|-------|------|-------|-------|------|
| 162 | – | 1.62 | 4.56 | 1.75 | 3.91 | 2.75 | 0.41 |
| 200 | – | 2.00 | 5.75 | 2.12 | 4.68 | 3.62 | 0.44 |
| 225 | – | 2.25 | 6.00 | 2.50 | 5.44 | 3.88 | 0.44 |
| 262 | – | 2.62 | 6.88 | 2.88 | 6.29 | 4.50 | 0.53 |
| 312 | – | 3.12 | 8.12 | 3.38 | 7.38 | 5.44 | 0.62 |
| 350 | – | 3.50 | 9.12 | 3.75 | 8.17 | 6.00 | 0.67 |
| 375 | – | 3.75 | 10.06 | 4.00 | 8.81 | 6.50 | 0.81 |
| 425 | – | 4.25 | 11.00 | 4.25 | 9.38 | 7.00 | 0.88 |
| 450 | – | 4.50 | 11.88 | 4.50 | 9.88 | 7.44 | 0.88 |
| 500 | 2.69 | 5.00 | 13.44 | 5.00 | 11.06 | 8.38 | 1.06 |
| 550 | 2.69 | 5.50 | 15.00 | 5.50 | 12.25 | 9.44 | 1.25 |
| 600 | 3.69 | 6.00 | 16.75 | 6.00 | 13.38 | 10.31 | 1.38 |
| 700 | 4.25 | 7.00 | 18.94 | 7.00 | 15.56 | 11.75 | 1.56 |
| 750 | 4.94 | 7.50 | 20.62 | 7.25 | 16.25 | 12.62 | 1.75 |
| 800 | 5.19 | 8.00 | 22.38 | 7.75 | 17.31 | 13.75 | 1.81 |
| 850 | 5.44 | 8.50 | 23.75 | 8.25 | 18.50 | 14.50 | 2.00 |
| 925 | 5.94 | 9.25 | 25.75 | 9.00 | 20.25 | 15.88 | 2.25 |



TYPE BMR SINGLE

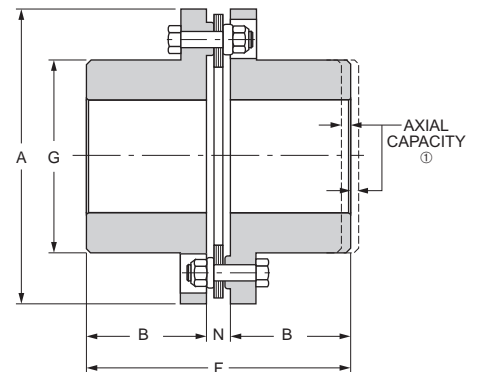

Engineering Data

| Coupling Size | Max Horsepower Per 100 RPM | Max. RPM | Max. Continuous Torque (lb.-in.) | Peak Overload Torque (lb.-in.) | ③ Weight (lb.) | ③ WR ² (lb.-in. ²) | ② Axial Capacity (in.) |
|---------------|----------------------------|----------|----------------------------------|--------------------------------|----------------|---|------------------------|
| | Service Factor | | | | | | |
| 162 | 9.1 | 2,500 | 5,740 | 6,888 | 6.5 | 14.5 | ±0.018 |
| 200 | 17.5 | 2,500 | 11,030 | 13,236 | 13 | 40.5 | ±0.018 |
| 225 | 24.7 | 2,500 | 15,575 | 18,690 | 15 | 58 | ±0.018 |
| 262 | 33.4 | 2,500 | 21,038 | 25,246 | 22 | 107 | ±0.022 |
| 312 | 37.5 | 2,500 | 23,650 | 28,380 | 40 | 283 | ±0.025 |
| 350 | 83.8 | 2,300 | 52,800 | 63,360 | 53 | 467 | ±0.025 |
| 375 | 126 | 2,200 | 79,442 | 95,330 | 70 | 735 | ±0.031 |
| 425 | 140 | 2,000 | 88,000 | 105,600 | 87 | 1,160 | ±0.034 |
| 450 | 216 | 1,900 | 136,125 | 163,350 | 107 | 1,540 | ±0.036 |
| 500 | 319 | 1,800 | 200,750 | 240,900 | 146 | 2,750 | ±0.041 |
| 550 | 436 | 1,800 | 275,055 | 330,066 | 210 | 4,930 | ±0.046 |
| 600 | 569 | 1,500 | 358,875 | 430,650 | 275 | 7,850 | ±0.051 |
| 700 | 724 | 1,250 | 456,500 | 547,800 | 410 | 15,300 | ±0.058 |
| 750 | 1,023 | 1,100 | 644,930 | 773,916 | 500 | 22,700 | ±0.062 |
| 800 | 1,291 | 1,000 | 813,780 | 976,536 | 645 | 40,520 | ±0.068 |
| 850 | 1,426 | 1,000 | 898,700 | 1,078,440 | 795 | 47,080 | ±0.072 |
| 925 | 2,033 | 1,000 | 1,281,280 | 1,537,536 | 1,010 | 70,600 | ±0.078 |

① Consult Rexnord for minimum rough bore on sizes 162-450.

② All Thomas disc couplings meet NEMA frame sleeve bearing motor specifications without modification or the addition of end-float restricting devices.

③ Weight and WR² shown at maximum bore.

Note: Dimensions subject to change. Certified dimensions of ordered material furnished on request.

THOMAS® SINGLE-FLEXING DISC COUPLINGS

TYPE SN SINGLE

Type SN single couplings are used for floating shaft applications where the user wishes to supply his own intermediate solid shaft, or for single-flexing applications where light-to-moderate radial loads occur. They are generally more economical than ST couplings.

Construction

Hubs: Carbon Steel
 Bolts: Alloy Steel
 Disc Packs: Tomaloy Tpack™
 Coatings Available: Black Oxide, Zinc, Cadmium

Other materials such as Stainless Steel, Monel and Inconel are available; please consult Rexnord Industries, Inc.

Misalignment: 1/8° per disc pack

Note:

Single-flexing couplings cannot accommodate parallel misalignment. They are not suitable for connecting equipment where both shafts are held rigidly in their own bearings.

General Dimensions (inch)

| Coupling Size | ① Max Bore | A | B | F | G | N |
|---------------|------------|-------|------|-------|-------|------|
| 100 | 1.16 | 3.22 | 1.38 | 3.21 | 1.69 | 0.45 |
| 125 | 1.38 | 3.84 | 1.63 | 3.78 | 2.06 | 0.52 |
| 162 | 1.88 | 4.47 | 1.88 | 4.30 | 2.75 | 0.54 |
| 200 | 2.25 | 5.44 | 2.13 | 4.83 | 3.28 | 0.57 |
| 226 | 2.63 | 5.81 | 2.63 | 5.84 | 3.78 | 0.58 |
| 262 | 3.13 | 6.69 | 3.00 | 6.47 | 4.50 | 0.47 |
| 312 | 3.63 | 7.81 | 3.38 | 7.26 | 5.25 | 0.50 |
| 350 | 4.00 | 8.75 | 3.75 | 8.04 | 5.88 | 0.54 |
| 375 | 4.50 | 9.69 | 4.00 | 8.59 | 6.50 | 0.59 |
| 425 | 4.75 | 10.50 | 4.25 | 9.12 | 7.00 | 0.62 |
| 450 | 5.13 | 11.31 | 4.50 | 9.78 | 7.44 | 0.78 |
| 500T | 5.38 | 12.88 | 5.00 | 10.78 | 8.38 | 0.78 |
| 550T | 6.00 | 14.44 | 5.50 | 11.91 | 9.44 | 0.91 |
| 600T | 6.50 | 16.00 | 6.00 | 12.98 | 10.25 | 0.98 |
| 700T | 7.50 | 18.25 | 7.00 | 15.20 | 11.75 | 1.20 |
| 750T | 8.00 | 19.81 | 7.50 | 16.27 | 12.63 | 1.27 |



TYPE SN SINGLE

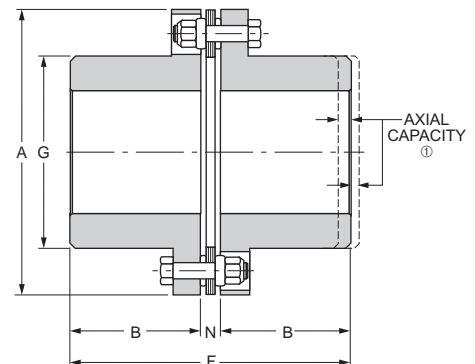

Engineering Data

| Coupling Size | Max Horsepower Per 100 RPM | ③ Max. RPM | Max. Continuous Torque (lb.-in.) | Peak Overload Torque (lb.-in.) | ③ Weight (lb.) | ③WR ² (lb.-in. ²) | ② Axial Capacity (in.) |
|---------------|----------------------------|------------|----------------------------------|--------------------------------|----------------|--|------------------------|
| | Service Factor 1 | | | | | | |
| 100 | 1.3 | 7,100 | 820 | 1,640 | 2.3 | 2.7 | ±0.019 |
| 125 | 3.5 | 6,500 | 2,230 | 4,460 | 3.8 | 6.5 | ±0.023 |
| 162 | 7.1 | 6,000 | 4,450 | 8,900 | 5.8 | 17.1 | ±0.018 |
| 200 | 13.6 | 5,500 | 8,600 | 17,200 | 11 | 37 | ±0.018 |
| 226 | 22.6 | 5,200 | 14,260 | 28,520 | 14 | 53 | ±0.018 |
| 262 | 52.1 | 4,800 | 32,830 | 65,660 | 23 | 117 | ±0.022 |
| 312 | 81.6 | 4,500 | 51,400 | 102,800 | 37 | 264 | ±0.026 |
| 350 | 106 | 4,100 | 66,900 | 133,800 | 52 | 459 | ±0.028 |
| 375 | 159 | 3,900 | 100,300 | 200,600 | 71 | 770 | ±0.031 |
| 425 | 213 | 3,700 | 134,300 | 268,600 | 89 | 1,160 | ±0.034 |
| 450 | 239 | 3,600 | 150,400 | 300,800 | 121 | 1,580 | ±0.036 |
| 500T | 391 | 2,800 | 246,400 | 492,800 | 150 | 2860 | ±0.041 |
| 550T | 524 | 2,500 | 330,400 | 660,800 | 210 | 5,130 | ±0.046 |
| 600T | 688 | 2,300 | 433,800 | 867,600 | 257 | 7,010 | ±0.051 |
| 700T | 1,071 | 2,000 | 674,800 | 1,349,600 | 390 | 12,100 | ±0.057 |
| 750T | 1,331 | 1,800 | 838,800 | 1,677,600 | 534 | 24,650 | ±0.062 |

For larger sizes, consult Rexnord. For ordering instructions, see pages 10-11.

① Consult Rexnord for minimum rough bore on sizes 162-450.

② All Thomas disc couplings meet NEMA frame sleeve bearing motor specifications without modification or the addition of end-float restricting devices.

③ Weight and WR² at maximum bore.

THOMAS® FLEXIBLE DISC COUPLINGS

HIGH PERFORMANCE THP

THP couplings are designed for use on high speed equipment where coupling size and weight must be kept to a minimum. Typically, these couplings connect prime movers such as motors, steam and gas turbines, rotary engines and gas expanders, to centrifugal and rotary compressors, generators, process and boiler feed pumps. Test stand and marine propulsion drives also benefit from this unique coupling design.

The flexing elements are precision-stamped from a high strength 300 series stainless steel. This material has been used successfully for many years in Thomas couplings manufactured for helicopter drive shaft applications. Special materials for hubs, spacers and/or flexing elements are available to meet unique application requirements.

Construction

Hubs and Center Member: Heat Treated 4140 and 4340 Alloy Steel
 Bolts: Aircraft quality Alloy Steel with twelve point wrenching pattern
 Disc Packs: High Strength 300 Series Stainless Steel
 Coatings Available: Black Oxide, Zinc, Cadmium, other coatings available per customer specifications

Other materials such as, Monel and Inconel are available; please consult Rexnord Industries, Inc.

System Analysis

A coupling is a critical component of any drive system. The basic coupling selection criteria is used to determine the size and style only. It is recommended that the system be analyzed for torsional and lateral stability using the specific coupling mass elastic data. The coupling weight, inertia, lateral stiffness, and torsional stiffness are available for this system analysis. It is the responsibility of the coupling user to assure the system, with the coupling as a component, properly functions.



General Dimensions (inch)

| Coupling Size | A | B | C | D | E | F | G ^② | ① Max Bore Hydraulic H | L | M | N |
|---------------|--------|-------|-------|-------|-------|--------|----------------|------------------------------|-------|--------|------|
| | | | | | | | | | | | |
| 519-6 | 6.375 | 2.594 | 18.00 | 3.875 | 3.625 | 24.312 | 3.750 | 2.5 | 0.125 | 5.312 | 4.56 |
| 519-8 | 6.438 | 2.594 | 18.00 | 3.875 | 3.625 | 24.312 | 3.750 | 2.5 | 0.125 | 5.312 | 4.56 |
| 638-6 | 7.688 | 3.094 | 18.00 | 4.625 | 4.375 | 25.438 | 4.500 | 3.0 | 0.125 | 6.375 | 5.00 |
| 638-8 | 7.688 | 3.094 | 18.00 | 4.625 | 4.375 | 25.438 | 4.500 | 3.0 | 0.125 | 6.375 | 5.05 |
| 744-6 | 8.875 | 3.688 | 18.00 | 5.438 | 5.125 | 26.625 | 5.250 | 3.5 | 0.125 | 7.438 | 5.29 |
| 744-8 | 8.875 | 3.688 | 18.00 | 5.438 | 5.125 | 26.625 | 5.250 | 3.5 | 0.125 | 7.438 | 5.31 |
| 850-6 | 10.125 | 4.188 | 18.00 | 6.250 | 5.875 | 27.750 | 6.000 | 4.0 | 0.125 | 8.312 | 6.26 |
| 850-8 | 10.125 | 4.188 | 18.00 | 6.250 | 5.875 | 27.750 | 6.000 | 4.0 | 0.125 | 8.312 | 6.32 |
| 948-6 | 11.438 | 4.688 | 18.00 | 7.000 | 6.562 | 28.875 | 6.750 | 4.5 | 0.125 | 9.344 | 7.26 |
| 948-8 | 11.438 | 4.688 | 18.00 | 7.000 | 6.562 | 28.875 | 6.750 | 4.5 | 0.125 | 9.344 | 7.27 |
| 1025-6 | 12.500 | 5.281 | 18.00 | 7.750 | 7.250 | 30.312 | 7.500 | 5.0 | 0.125 | 10.344 | 8.12 |
| 1025-8 | 12.500 | 5.281 | 18.00 | 7.750 | 7.250 | 30.312 | 7.500 | 5.0 | 0.125 | 10.344 | 8.19 |

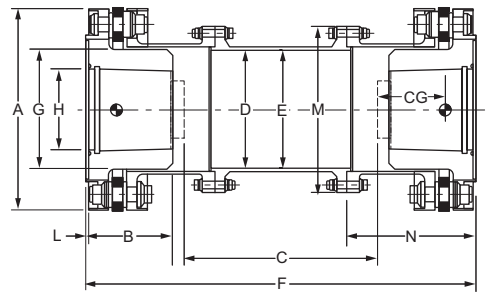

Engineering Data

| Cont. Size | ① Max. Standard Bore (in.) | ③ ④ Max. Cont. Torque Rating (lb.-in.) | Max. Speed RPM | ⑤ Wt. (lb.) | ⑤ WR ² (lb.-in. ²) | ⑤ Half Coupling C.G. (in.) | ⑤ Torsional Stiffness Kt x 10 ⁶ (lb.-in./Rad.) | Spacer Tube Per Inch | | | ⑥ Axial Capacity (Continuous) (in.) |
|------------|-------------------------------|---|----------------|----------------|--|-------------------------------|--|-------------------------------------|--------------|---|--|
| | | | | | | | | Kt x 10 ⁶ (lb.-in./Rad.) | Weight (lb.) | WR ² (lb.-in. ²) | |
| 442-6 | 2.0 | 27,000 | 28,500 | 21.3 | 65.8 | 1.64 | 0.782 | 30.5 | 0.33 | 0.74 | ±0.120 |
| 519-6 | 2.5 | 51,000 | 24,000 | 35.3 | 163 | 2.01 | 1.60 | 59.6 | 0.41 | 1.45 | ±0.145 |
| 519-8 | 2.5 | 75,000 | 23,800 | 36.2 | 173 | 2.01 | 1.84 | 59.6 | 0.41 | 1.45 | ±0.100 |
| 638-6 | 3.0 | 78,000 | 19,900 | 54.5 | 365 | 2.43 | 2.85 | 103 | 0.50 | 2.51 | ±0.175 |
| 638-8 | 3.0 | 120,000 | 19,900 | 55.4 | 378 | 2.44 | 3.27 | 103 | 0.50 | 2.51 | ±0.125 |
| 744-6 | 3.5 | 124,500 | 17,200 | 82.3 | 730 | 2.87 | 5.01 | 208 | 0.73 | 5.07 | ±0.205 |
| 744-8 | 3.5 | 176,250 | 17,200 | 83.7 | 759 | 2.88 | 5.81 | 208 | 0.73 | 5.07 | ±0.145 |
| 850-6 | 4.0 | 195,000 | 15,100 | 125 | 1,470 | 3.18 | 8.12 | 378 | 1.00 | 9.20 | ±0.235 |
| 850-8 | 4.0 | 294,000 | 15,100 | 127 | 1,530 | 3.19 | 9.54 | 378 | 1.00 | 9.20 | ±0.165 |
| 948-6 | 4.5 | 285,000 | 13,400 | 174 | 2,600 | 3.57 | 12.8 | 617 | 1.31 | 15.0 | ±0.265 |
| 948-8 | 4.5 | 427,500 | 13,400 | 178 | 2,730 | 3.57 | 15.4 | 617 | 1.31 | 15.0 | ±0.185 |
| 1025-6 | 5.0 | 375,000 | 12,250 | 235 | 4,230 | 4.02 | 18.5 | 954 | 1.65 | 23.2 | ±0.290 |
| 1025-8 | 5.0 | 579,000 | 12,250 | 240 | 4,430 | 4.04 | 22.3 | 954 | 1.65 | 23.2 | ±0.205 |

① For larger bores, consult Rexnord.

② May be reduced for smaller shaft sizes. Consult Rexnord.

③ Minimum application factor to be applied = 1.5.

④ Max. peak overload torque = 1.33 x max. cont. torque

⑤ Information based on standard dimensional data shown.

⑥ Max. transient axial misalignment = 120% of values shown above.

Consult Rexnord with specific application requirements.

Note: Catalog dimensions subject to change.

Note: Dimensions subject to change. Certified dimensions of ordered material furnished on request.

THOMAS® FLEXIBLE DISC COUPLINGS

HIGH PERFORMANCE SERIES 63

Series 63 couplings incorporate a patented* one-piece disc/diaphragm flexing element for positive torque transmission with low restoring forces. This unitized assembly accommodates misalignment and transmits torque through a multiple disc arrangement which provides redundancy in construction with a high degree of reliability. Pilot plates on the sides of each flexing element give accurate, repeatable registration of coupling components, and retain original dynamic balance repeatability while protecting the flexing members from damage.

Series 63 couplings are ideal for the most demanding drive requirements. Prime movers include motor, steam and gas turbines, rotary engines, and gas expanders. Driven equipment applications include centrifugal and rotary compressors, generators, test stands, boiler feed pumps and other multi-stage pumps, and marine propulsion drives. Special designs available for torsional tuning and reduced moment.

* U.S. Patent 4055966

Construction

Hubs and Center Member: Heat Treated 4140 Steel
 Bolts: Alloy Steel
 Disc Packs: High Strength 300 Series Stainless Steel
 Coatings Available: Black Oxide, Zinc, Cadmium, other coatings available per customer specifications

Other materials such as Stainless Steel, Monel and Inconel are available; please consult Rexnord Industries, Inc.

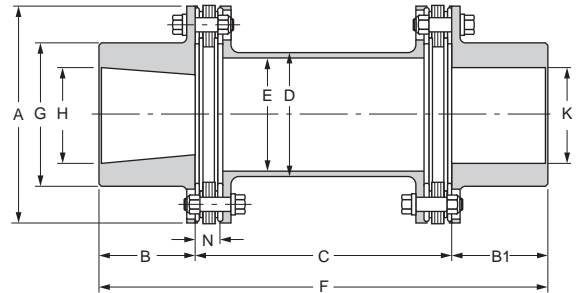
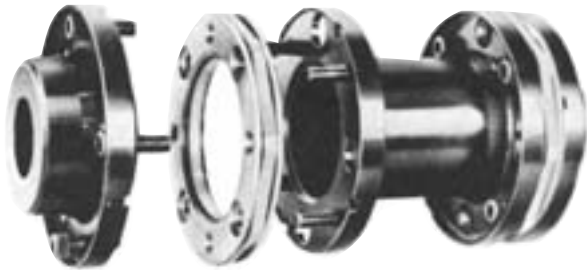

SERIES 63 COUPLINGS MAY BE FURNISHED TO MEET REQUIREMENTS OF API 671

General Dimensions (inch)

| Coupling Size | Max. Bore | | A | B | B1 | ① Std. C | Min. C | D | E | F | ② G Max. | N | Axial Capacity (in.) |
|---------------|-------------|---------|-------|------|------|----------|--------|-------|-------|-------|----------|------|----------------------|
| | Hydraulic H | Keyed K | | | | | | | | | | | |
| 162 | 2.00 | 1.88 | 4.25 | 2.06 | 1.88 | 5.00 | 3.25 | 2.41 | 2.22 | 8.94 | 2.81 | 0.53 | ±0.050 |
| 200 | 2.62 | 2.45 | 5.47 | 2.75 | 2.45 | 5.00 | 4.12 | 3.38 | 3.19 | 10.20 | 3.68 | 0.68 | ±0.070 |
| 225 | 2.81 | 2.62 | 5.72 | 2.91 | 2.62 | 5.00 | 4.25 | 3.50 | 3.31 | 10.53 | 3.94 | 0.70 | ±0.055 |
| 262 | 3.22 | 3.00 | 6.72 | 3.38 | 3.00 | 6.00 | 4.75 | 3.94 | 3.69 | 12.38 | 4.50 | 0.78 | ±0.060 |
| 312 | 3.75 | 3.50 | 8.00 | 3.94 | 3.50 | 6.00 | 5.00 | 4.75 | 4.44 | 13.44 | 5.25 | 0.94 | ±0.075 |
| 350 | 4.16 | 3.88 | 8.91 | 4.38 | 3.88 | 7.00 | 6.44 | 5.00 | 4.69 | 15.26 | 5.81 | 1.13 | ±0.080 |
| 375 | 4.69 | 4.38 | 9.88 | 4.88 | 4.38 | 7.00 | 6.62 | 6.06 | 5.72 | 16.26 | 6.56 | 1.17 | ±0.090 |
| 425 | 4.97 | 4.62 | 10.69 | 5.28 | 4.62 | 8.00 | 7.37 | 6.50 | 6.06 | 17.90 | 6.94 | 1.31 | ±0.100 |
| 450 | 5.36 | 5.00 | 11.50 | 5.69 | 5.00 | 8.00 | 7.62 | 7.00 | 6.55 | 18.69 | 7.50 | 1.37 | ±0.110 |
| 500 | 6.00 | 5.58 | 13.12 | 6.47 | 5.58 | 9.00 | 8.50 | 7.75 | 7.19 | 21.05 | 8.38 | 1.48 | ±0.120 |
| 550 | 6.70 | 6.25 | 14.75 | 7.38 | 6.25 | 9.88 | 9.88 | 8.75 | 8.06 | 23.51 | 9.38 | 1.73 | ±0.140 |
| 600 | 7.33 | 6.83 | 16.38 | 8.06 | 6.83 | 11.25 | 11.25 | 9.38 | 8.58 | 26.14 | 10.25 | 2.03 | ±0.150 |
| 700 | 8.17 | 7.62 | 18.69 | 8.97 | 7.62 | 12.00 | — | 10.63 | 9.67 | 28.59 | 11.44 | 2.10 | ±0.175 |
| 750 | 8.84 | 8.25 | 20.31 | 9.69 | 8.25 | 14.00 | — | 11.81 | 10.80 | 31.94 | 12.38 | 2.30 | ±0.190 |

For Complete Selection, Dimensions And Mass-Elastic Data, Refer To Rexnord High Performance Coupling Catalog Or Contact Rexnord. Larger sizes are available. Consult Rexnord with specific application requirements.

① Standard dimension - may be modified as necessary.

② "G" dimension at listed maximum bore. Dimension "G" will vary depending on bore size.

THOMAS® FLEXIBLE DISC COUPLINGS

HIGH PERFORMANCE SERIES 63

| Engineering Data | | | | Standard Mass-Elastic Data | | | | | | |
|------------------|--------------------|----------------------------------|--------------------------------|----------------------------|---|---|------------|------------------------|---|---|
| Cplg. Size | ③ Max. Speed (RPM) | Max. Continuous Torque (lb.-in.) | Peak Overload Torque (lb.-in.) | Weight (lb.) | WR ² (lb.-in. ²) | K _t x 10 ⁶ (lb.-in./Rad.) | C.G. (in.) | Change Per Inch of "C" | | |
| | | | | | | | | Weight (lb.) | WR ² (lb.-in. ²) | K _t x 10 ⁶ (lb.-in./Rad.) |
| 162 | 36,000 | 5,890 | 14,700 | 7.76 | 16.5 | 0.502 | 0.37 | 0.19 | 0.26 | 10.5 |
| 200 | 28,600 | 13,600 | 34,000 | 16.4 | 59.8 | 1.78 | 0.56 | 0.27 | 0.76 | 29.9 |
| 225 | 26,700 | 21,100 | 52,700 | 19.2 | 78.2 | 2.33 | 0.62 | 0.28 | 0.82 | 33.6 |
| 262 | 22,500 | 37,800 | 94,500 | 30.7 | 167 | 3.90 | 0.67 | 0.42 | 1.53 | 62.7 |
| 312 | 19,100 | 64,100 | 160,000 | 51.0 | 397 | 5.66 | 0.74 | 0.63 | 3.33 | 137 |
| 350 | 17,200 | 81,900 | 205,000 | 69.2 | 666 | 9.54 | 0.79 | 0.67 | 3.9 | 160 |
| 375 | 15,600 | 126,000 | 315,000 | 93.1 | 1,100 | 12.30 | 0.99 | 0.89 | 7.72 | 317 |
| 425 | 14,300 | 169,000 | 423,000 | 118 | 1,630 | 19.0 | 0.97 | 1.21 | 11.9 | 491 |
| 450 | 13,300 | 213,000 | 533,000 | 147 | 2,330 | 21.0 | 1.09 | 1.35 | 15.5 | 636 |
| 500 | 11,600 | 316,000 | 790,000 | 214 | 4,350 | 34.80 | 1.20 | 1.85 | 25.8 | 1,060 |
| 550 | 10,300 | 454,000 | 1,135,000 | 308 | 7,870 | 49.90 | 1.35 | 2.54 | 45 | 1,850 |
| 600 | 9,300 | 630,000 | 1,575,000 | 416 | 13,000 | 61.3 | 1.37 | 3.15 | 63.5 | 2,610 |
| 700 | 8,200 | 903,000 | 2,258,000 | 605 | 24,600 | 100 | 1.46 | 4.25 | 110 | 4,510 |
| 750 | 7,500 | 1,150,000 | 2,875,000 | 773 | 37,000 | 131 | 1.52 | 5.02 | 162 | 6,600 |

Weight and C.G. data based on standard "C" dimension, maximum hydraulic bores (H) and hydraulic hub lengths (B). Torsional stiffness (K_t) assumes a one-third shaft penetration factor. To determine K_t for a coupling with longer than standard "C" dimension, use the following formula $K_t = \frac{1}{\frac{1}{K_t} + \frac{\Delta L}{\Delta K_t}}$ where ΔL = additional "C" dimension required ΔK_t = torsional stiffness change per inch of "C" dimension and $1/K_t$ - inverse of catalog value.

For Complete Selection, Dimensions And Mass-Elastic Data, Refer To Rexnord High Performance Coupling Catalog Or Contact Rexnord. Larger sizes are available. Consult Rexnord with specific application requirements.

③ Consult Rexnord with higher speed requirements.

SERIES 63 UNITIZED FLEXING ELEMENT



UNITIZED FLEXING ELEMENT

Features and Benefits

- One-piece assembly—no loose parts
- Replaceable in the field
- Individually balanced
- Assures repeatable coupling dynamic balance
- Piloted fit between hubs and spacer
- Complies with API 671
- Visual inspection without coupling disassembly
- Compact and lightweight
- Easy to use

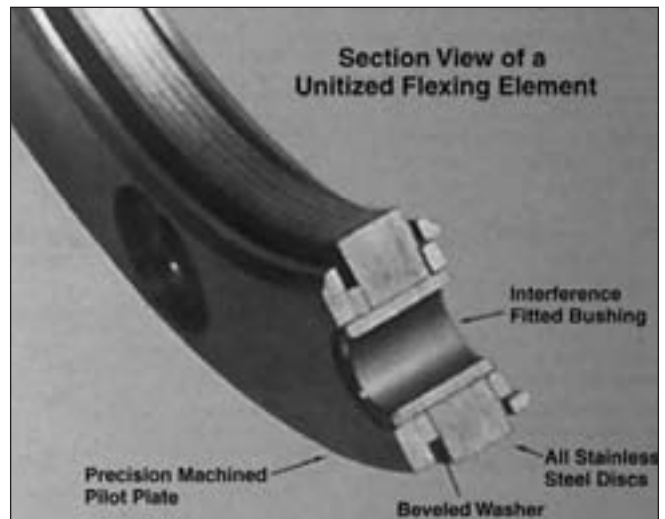

NOTE: A coupling is a critical component of any drive system. The basic coupling selection criteria is used to determine the size and style only. It is recommended that the system be analyzed for torsional and lateral stability using the specific coupling mass elastic data. The coupling weight, inertia, lateral stiffness, and torsional stiffness are available for this system analysis. It is the responsibility of the coupling user to assure the system, with the coupling as a component, properly functions.

THOMAS® MINIATURE COUPLINGS

THOMAS MINIATURE FLEXIBLE DISC COUPLINGS

GUIDE TO PROPER DESIGNATION OF HUBS

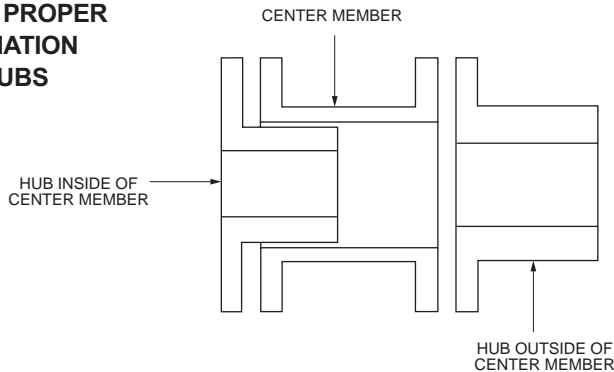

MATERIAL SPECIFICATIONS FOR STANDARD COUPLINGS:

Hubs and Center Member: Aluminum Alloy, Anodized

Rivets: Brass

Washers: Brass

Discs: Stainless Steel, Beryllium

Set screws: 18-8 Stainless Steel, Passivated

Available with electronically insulated phenolic material

STYLE CC

This coupling has both hubs inverted and is designed to fit shafts normally encountered at a given torque range. Ideal for use where space limitations require close coupling of the shafts.

General Dimensions (inch)

| Coupling Size | A | B | C | F | T | ① Torque Capacity (lb.-in.) |
|---------------|--------|--------|------|--------|-------|-----------------------------|
| 12 | 1/2 | 1/4 | 1/32 | 17/32 | 0.018 | 1.1 |
| 18 | 3/4 | 3/8 | 1/16 | 13/16 | 0.023 | 2.2 |
| 25 | 1 | 1/2 | 1/16 | 1 1/16 | 0.025 | 4.7 |
| 37 | 1 7/16 | 11/16 | 1/8 | 1 1/2 | 0.035 | 19.0 |
| 50 | 1 3/4 | 15/16 | 1/8 | 2 | 0.045 | 75.0 |
| 62 | 2 1/4 | 1 1/16 | 1/8 | 2 1/4 | 0.060 | 300 |
| 75 | 2 1/2 | 1 3/16 | 1/8 | 2 1/2 | 0.060 | 440 |
| 100 | 3 | 1 3/8 | 1/4 | 3 | 0.060 | 700 |

① Torque capacities are based on smooth drives with moderate torque fluctuations. Reduce ratings to 1/3 the value shown for severe applications such as indexing drives where torque reversals occur.

② All Thomas disc couplings meet NEMA frame sleeve bearing motor specifications without modification or the addition of end-float restricting devices.

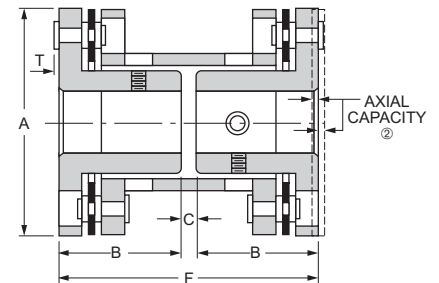

STYLE CA

This design of our miniature coupling has one inverted hub to accept a normal shaft and one extended hub to accommodate oversize shafts. It also accommodates a larger shaft gap than the Style CC.

General Dimensions (inch)

| Coupling Size | A | B | C | F | G | T | ① Torque Capacity (lb.-in.) |
|---------------|--------|--------|-------|---------|--------|-------|-----------------------------|
| 12 | 1/2 | 1/4 | 15/64 | 47/64 | 5/16 | 0.018 | 1.1 |
| 18 | 3/4 | 3/8 | 3/8 | 1 1/8 | 15/32 | 0.023 | 2.2 |
| 25 | 1 | 1/2 | 15/32 | 1 15/32 | 5/8 | 0.025 | 4.7 |
| 37 | 1 7/16 | 11/16 | 11/16 | 2 1/16 | 7/8 | 0.035 | 19.0 |
| 50 | 1 3/4 | 15/16 | 29/32 | 2 29/32 | 1 1/16 | 0.045 | 75.0 |
| 62 | 2 1/4 | 1 1/16 | 1 | 3 1/8 | 1 3/8 | 0.060 | 300 |
| 75 | 2 1/2 | 1 3/16 | 1 1/8 | 3 1/2 | 1 5/8 | 0.060 | 440 |
| 100 | 3 | 1 3/8 | 1 3/8 | 4 1/8 | 1 7/8 | 0.060 | 700 |

① Torque capacities are based on smooth drives with moderate torque fluctuations. Reduce ratings to 1/3 the value shown for severe applications such as indexing drives where torque reversals occur.

② All Thomas disc couplings meet NEMA frame sleeve bearing motor specifications without modification or the addition of end-float restricting devices.

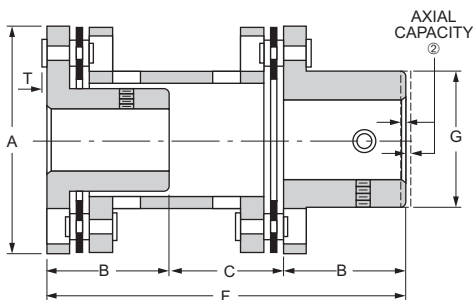

THOMAS® MINIATURE COUPLINGS

STYLE CB & CBC

This coupling design has both hubs extended to accept two oversized shafts. Shaft gap is larger than that of the Style CA or CC couplings. Style CBC is the newest addition to our miniature coupling line. It offers clamping hubs that are an integral part of the coupling. The clamping hubs assure positive fit on the shafts. There are no loose parts to handle during installation. The Style CBC coupling has the same dimensions and torque capacities as the Style CB. Consult Rexnord Industries, Inc. for additional design and engineering data.

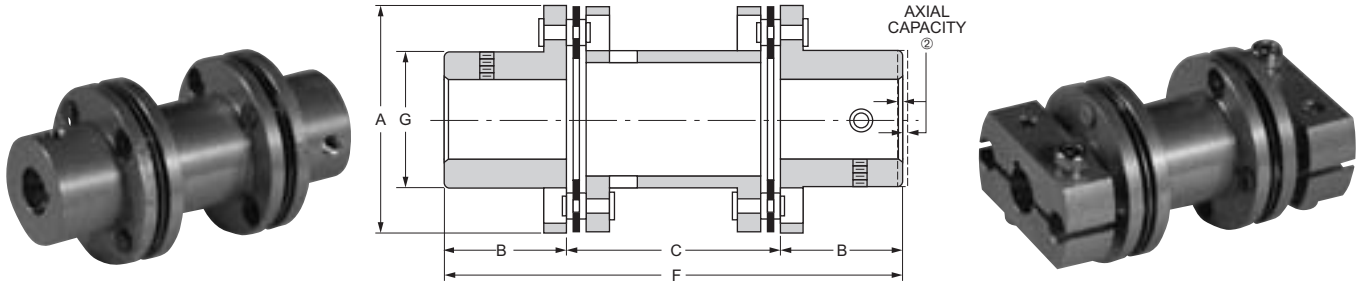

General Dimensions (inch)

| Coupling Size | A | B | C | F | G | ① Torque Capacity (lb.-in.) |
|---------------|--------|--------|---------|--------|--------|-----------------------------|
| 12 | 1/2 | 1/4 | 7/16 | 15/16 | 5/16 | 1.1 |
| 18 | 3/4 | 3/8 | 11/16 | 1 7/16 | 15/32 | 2.2 |
| 25 | 1 | 1/2 | 7/8 | 1 7/8 | 5/8 | 4.7 |
| 37 | 1 7/16 | 11/16 | 1 1/4 | 2 5/8 | 7/8 | 19.0 |
| 50 | 1 3/4 | 15/16 | 1 11/16 | 3 9/16 | 1 1/16 | 75.0 |
| 62 | 2 1/4 | 1 1/16 | 1 7/8 | 4 | 1 3/8 | 300 |
| 75 | 2 1/2 | 1 3/16 | 2 1/8 | 5 | 1 5/8 | 440 |
| 100 | 3 | 1 3/8 | 2 1/2 | 5 | 1 7/8 | 700 |

① Weight and WR² at maximum bore.

② All Thomas disc couplings meet NEMA frame sleeve bearing motor specifications without modification or the addition of end-float restricting devices.

STYLES CC, CA, CB & CBC RATINGS AND MASS ELASTIC DATA

| Size No. | Max. RPM | ① Approx. Weight (oz.) | ① Approx. WR ² (oz.-in. ²) | Torsional Rigidity K _t x 10 ⁶ (oz.-in./Rad.) | Max. Angular Misalignment, Continuous Per Flexing Element | Max. Parallel Misalignment, Continuous (in) | ② Axial Capacity (in.) |
|----------|----------|------------------------|---|--|---|---|------------------------|
| 12 | 150,000 | 0.09 | 0.0026 | 0.148 | 2° | 0.015 | ±0.016 |
| 18 | 100,000 | 0.29 | 0.0177 | 0.0908 | 2° | 0.015 | ±0.016 |
| 25 | 80,000 | 0.74 | 0.0799 | 0.037 | 2° | 0.028 | ±0.031 |
| 37 | 55,000 | 2.02 | 0.4740 | 0.00554 | 1.5° | 0.028 | ±0.031 |
| 50 | 45,000 | 4.02 | 1.418 | 0.00362 | 1° | 0.028 | ±0.031 |
| 62 | 35,000 | 9.36 | 4.99 | 0.00139 | 0.67° | 0.028 | ±0.031 |
| 75 | 30,000 | 11.57 | 8.61 | 0.00089 | 0.67° | 0.028 | ±0.031 |
| 100 | 25,000 | 20.00 | 23.00 | 0.00066 | 0.50° | 0.020 | ±0.031 |

① Weight and WR² at maximum bore.

② All Thomas disc couplings meet NEMA frame sleeve bearing motor specifications without modification or the addition of end-float restricting devices.

THOMAS® MINIATURE COUPLINGS

STYLE CE

Two single-flexing units are connected by a tubular shaft in this type of miniature coupling. It's designed to span large distances between shafts. Ideal for those applications where a large amount of parallel misalignment is anticipated.

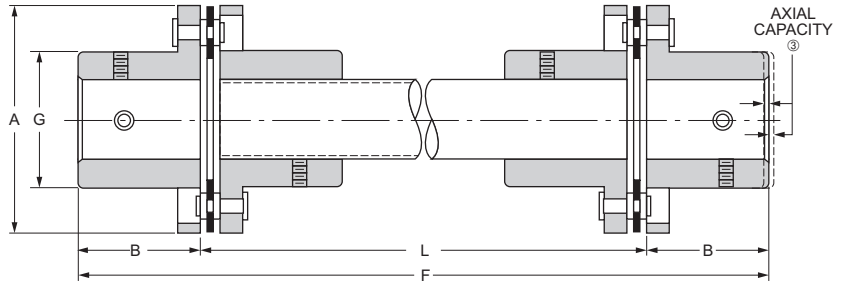

General Dimensions (inch)

| Coupling Size | A | B | F | G | L | ② Torque Capacity (lb.-in.) | ① Weight (oz) | Weight Change per inch of "L" (oz.) |
|---------------|--------|--------|---------------------------|--------|-------------------------------|-----------------------------|---------------|-------------------------------------|
| 12 | 1/2 | 1/4 | Varies With "L" Specified | 5/16 | Variable To Suit Requirements | 1.1 | 0.45 | 0.027 |
| 18 | 3/4 | 3/8 | | 15/32 | | 2.2 | 0.97 | 0.048 |
| 25 | 1 | 1/2 | | 5/8 | | 4.7 | 1.70 | 0.059 |
| 37 | 1 7/16 | 11/16 | | 7/8 | | 19.0 | 4.10 | 0.110 |
| 50 | 1 3/4 | 15/16 | | 1 1/16 | | 75.0 | 7.80 | 0.180 |
| 62 | 2 1/4 | 1 1/16 | | 1 3/8 | | 300 | 14.30 | 0.220 |
| 75 | 2 1/2 | 1 3/16 | | 1 5/8 | | 440 | 18.10 | 0.380 |
| 100 | 3 | 1 3/8 | | 1 7/8 | | 700 | | |

① Weight calculated at maximum bore and "L" = 12 inches.

② Torque capacities are based on smooth drives with moderate torque fluctuations. Reduce ratings to 1/3 the value shown for severe applications such as indexing drives where torque reversals occur.

③ All Thomas disc couplings meet NEMA frame sleeve bearing motor specifications without modification or the addition of end-float restricting devices.

④ For WR², misalignment capacities, and torsional rigidity, consult Rexnord.

MINIATURE COUPLINGS STANDARD BORE SIZES ①

CC, CA, CB, CBC & CE Couplings

| Coupling Size | Bores ② ③ (in.) | | Coupling Size | Bores ② ③ (in.) | |
|---------------|--------------------------|---------------------------|---------------|--------------------------|---------------------------|
| | Hub Inside Center Member | Hub Outside Center Member | | Hub Inside Center Member | Hub Outside Center Member |
| 12 | 0.0781, 0.0937 | 0.1200, 0.1250 | 50 | 0.2505, 0.3130 | 0.2505, 0.3130 |
| | 0.1200, 0.1250 | 0.1562, 0.1875 | | 0.3755, 0.4380 | 0.3755, 0.4380 |
| 18 | 0.0937, 0.1200 | 0.1250, 0.1562 | 62 | 0.3755, 0.4380 | 0.4380, 0.5005 |
| | 0.1250, 0.1562 | 0.1875, 0.2500 | | 0.5005, 0.6255 | 0.6255, 0.7505 |
| 25 | 0.1255, 0.1880 | 0.1255, 0.1880 | 75 | 0.4380, 0.5005 | 0.5005, 0.6255 |
| | 0.2505 | 0.2505, 0.3130 | | 0.6255, 0.7505 | 0.7505, 0.8755 |
| 37 | 0.1255, 0.1880 | 0.1880, 0.2505 | 100 | 0.6255, 0.7505 | 0.7505, 0.8755 |
| | 0.2505, 0.3130 | 0.3130, 0.3755 | | 0.8755, 1.0005 | 1.0005, 1.1255 |
| | 0.3755 | 0.4380, 0.5005 | | | 1.2505 |

① Coupling not available with rough bore. Other bore sizes can be furnished. Consult Rexnord.

② Tolerances. Sizes 12 and 18, ±0.0003". Other sizes, ±0.0005".

③ The largest bore shown for each hub is maximum allowable bore. If larger bore is required, consult Rexnord.

SPECIAL FLEXIBLE DISC COUPLINGS

The following pages illustrate a sampling of the special disc coupling products designed and manufactured by Rexnord Industries, Inc. For applications requiring special coupling designs, please contact your Rexnord Industries, Inc. representative.

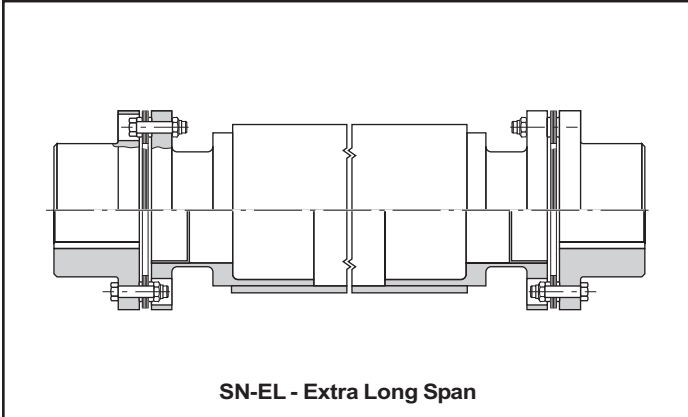

SN-EL - Extra Long Span

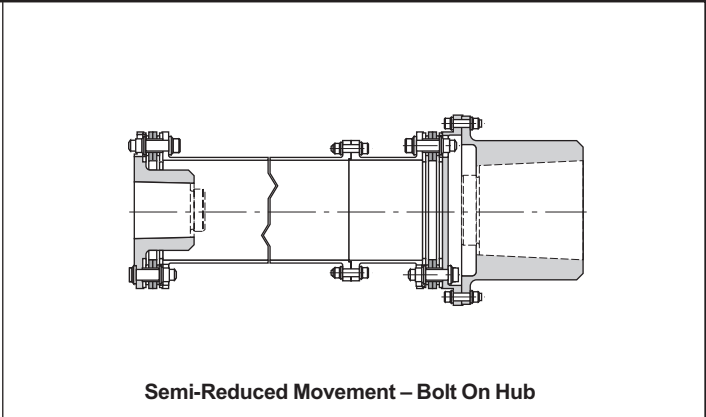

Semi-Reduced Movement - Bolt On Hub

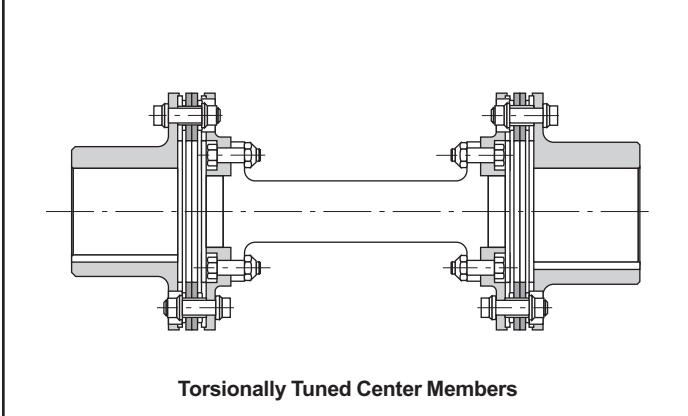

Torsionally Tuned Center Members

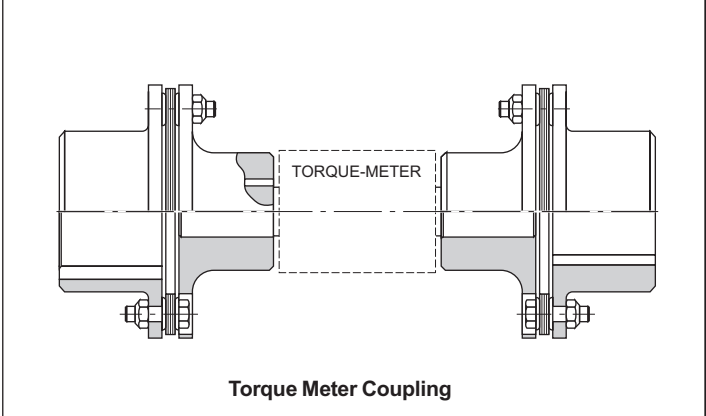

Torque Meter Coupling

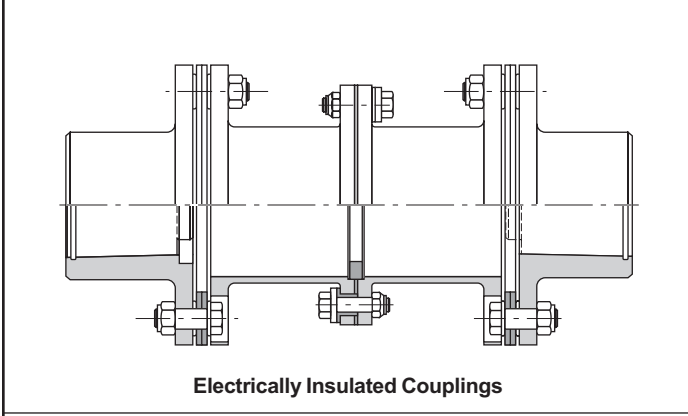

Electrically Insulated Couplings

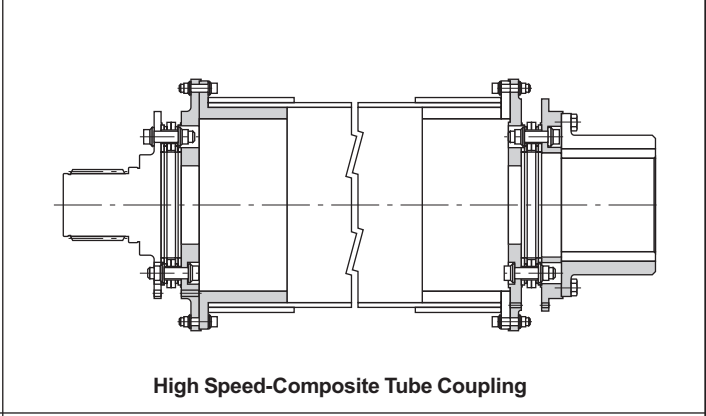

High Speed-Composite Tube Coupling

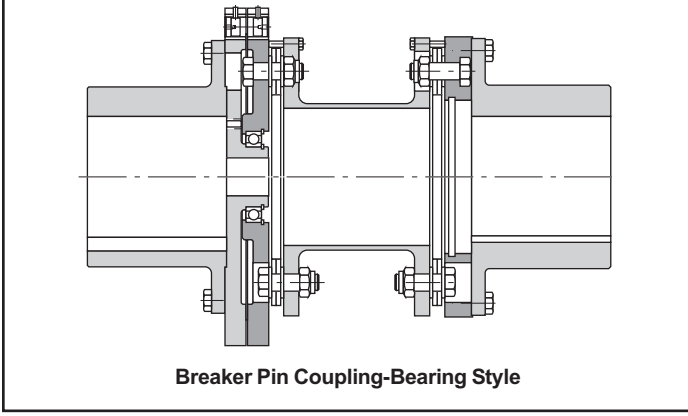

Breaker Pin Coupling-Bearing Style

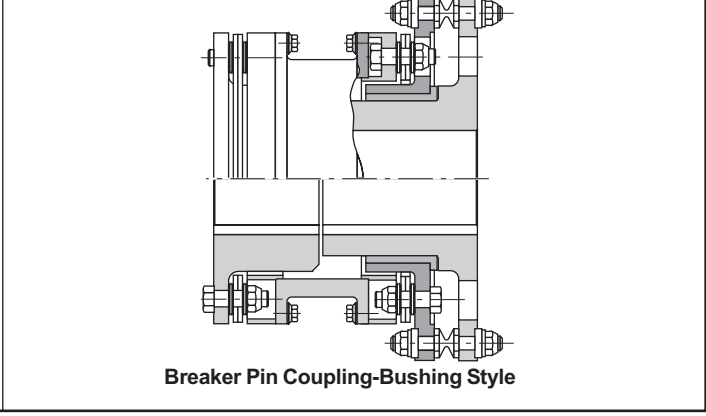

Breaker Pin Coupling-Bushing Style

SPECIAL FLEXIBLE DISC COUPLINGS

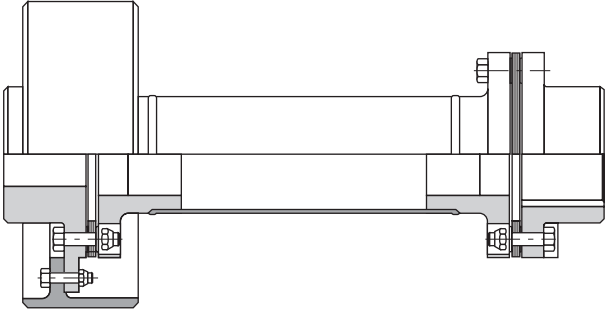
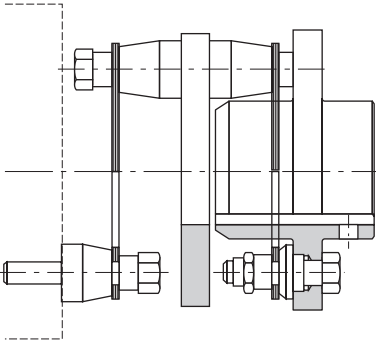
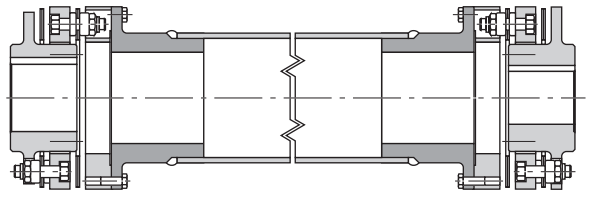
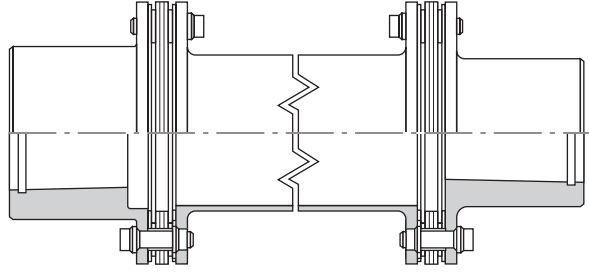
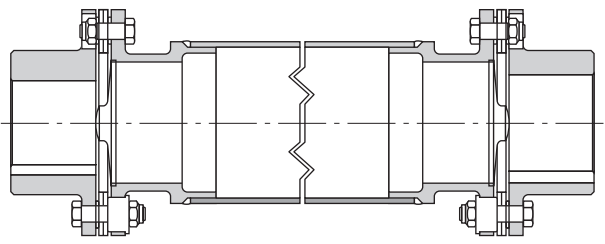
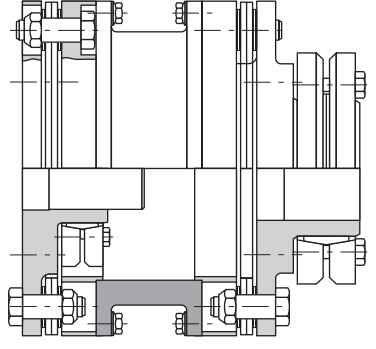
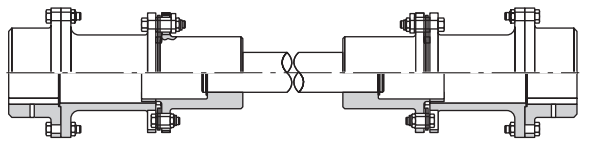
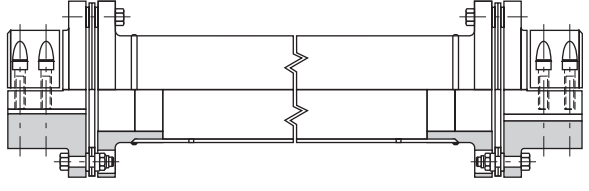
| | |
|---|---|
|  <p>Brake Drum Hub</p> |  <p>Motor-Tachometer Coupling</p> |
|  <p>Double Disc Packs Provide High Axial Capacity</p> |  <p>Hydraulic Hub Mounting</p> |
|  <p>Axial Limiting Stops</p> |  <p>Shrink Disc Hub Mounting</p> |
|  <p>Slide Coupling For Axial Positioning</p> |  <p>Clamp Hub Mounting</p> |

THOMAS® COUPLINGS

TYPE SN ADJUSTABLE

Type SN adjustable couplings were developed as emergency replacements for standard Type SN couplings and are available from stock in most sizes required for cooling tower applications. Each shaft may be adjusted thru a four-inch length range, using a special compression bushing to lock the shaft in place once the length is set.

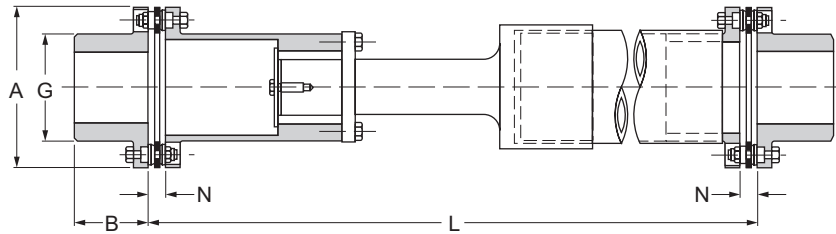

General Dimensions (inch) & Engineering Data

| Coupling Size | Max Bore | A | B | G | H | Min. "L" | Adjustment Range | Weight (lb.) | Weight Change Per Inch of "L" (lb.) | WR ² (lb.-in. ²) | WR ² Change per inch of "L" (lb.-in. ²) | ① Axial Capacity (in.) |
|---------------|----------|------|------|------|------|----------|------------------|--------------|-------------------------------------|---|--|------------------------|
| 162 | 1.88 | 4.47 | 1.88 | 2.75 | 0.54 | 14.25 | 4.00 | 19 | 0.13 | 37 | 0.22 | ± 0.036 |
| 200 | 2.25 | 5.44 | 2.12 | 3.28 | 0.57 | 15.12 | 4.00 | 30 | 0.29 | 80 | 0.56 | ± 0.036 |
| 226 | 2.62 | 5.81 | 2.62 | 3.78 | 0.58 | 17.28 | 4.00 | 43 | 0.33 | 151 | 0.82 | ± 0.036 |
| 262 | 3.12 | 6.69 | 3.00 | 4.50 | 0.47 | 18.88 | 4.00 | 61 | 0.41 | 253 | 1.60 | ± 0.043 |

① All Thomas disc couplings meet NEMA frame sleeve bearing motor specifications without modification or the addition of end-float restricting devices.

② Weight and WR² at maximum bore.

Note: See page 27 for selection data.

REX® THOMAS® BACKSTOP

- Bolts Directly to Thomas SN & TSN-CT Hubs
- Prevents reverse shaft rotation of Cooling Tower Fans
- All Stainless Steel Construction
- Available from Stock
- For non-Corrosive environments this can be supplied in carbon steel.

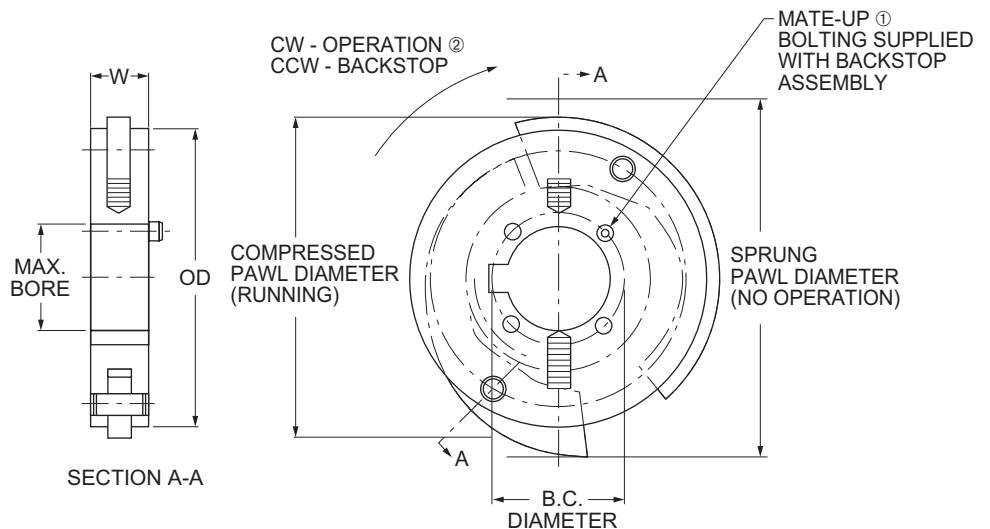

Bolt-On Backstop Tabulation (inch)

| Coupling Size | Max Bore | Mating Hub bckstop Bolting Info | | | | OD | W (Ref) | Pawl Dia. (Ref) | | Compressed Speed (RPM Ref) |
|---------------|----------|---------------------------------|---------------------|------------|------------------------|------|---------|-----------------|--------|----------------------------|
| | | B.C. Dia. | Capscrew Size | Min Tap DP | Tight Torque (lb.-in.) | | | Compressed | Sprung | |
| 162 | 1.88 | 2.312 | 1/4 - 20 NC x 1.50 | 0.62 | 25 | 5.25 | 1.00 | 5.69 | 6.50 | 450 RPM Ref |
| 200 | 2.12 | 2.688 | 1/4 - 20 NC x 1.50 | 0.62 | 25 | | | | | |
| 226 | 2.62 | 3.250 | 1/4 - 20 NC x 1.50 | 0.62 | 40 | | | | | |
| 262 | 3.12 | 3.875 | 3/8 - 16 NC x 1.75 | 0.88 | 142 | 9.12 | 1.12 | 9.19 | 10.56 | 400 RPM Ref |
| 312 | 3.62 | 4.438 | 7/16 - 14 NX x 2.00 | 1.12 | 225 | | | | | |
| 350/375 | 4.00 | 4.875 | 1/2 - 13 NC x 2.00 | 1.12 | 350 | | | | | |

Special integral hub/backstop can be supplied.

① 162 & 200 size supplied with (4) socket head capscrews. All other sizes supplied with (4) hex head capscrews.

② Backstop may be inversely mounted for opposite rotation.

World Class Customer Service

For more than 100 years, the dedicated people of Rexnord have delivered excellence in quality and service to our customers around the globe. Rexnord is a trusted name when it comes to providing skillfully engineered products that improve productivity and efficiency for industrial applications worldwide. We are committed to exceeding customer expectations in every area of our business: product design, application engineering, operations, and customer service.

Because of our customer focus, we are able to thoroughly understand the needs of your business and have the resources available to work closely with you to reduce maintenance costs, eliminate redundant inventories and prevent equipment down time.

Rexnord represents the most comprehensive portfolio of power transmission and conveying components in the world with the brands you know and trust.

Thomas and Rexnord are registered trademarks of Rexnord Industries, LLC. All rights reserved.

WORLDWIDE CUSTOMER SERVICE

AUSTRALIA

Rexnord Australia Pty. Ltd.
Picton, New South Wales
Phone: 61-2-4677-3811
Fax: 61-2-4677-3812

BRAZIL

Rexnord Correntes Ltda.
Sao Leopoldo - RS
Phone: 55-51-579-8022
Fax: 55-51-579-8029

CANADA

Rexnord Canada Ltd.
Scarborough, Ontario
Phone: 1-416-297-6868
Fax: 1-416-297-6873

CHINA

Rexnord China
Shanghai, China
Phone: 86-21-62701942
Fax: 86-21-62701943

EUROPE

Rexnord NV/SA
Mechelen, Belgium
Phone: 32-15-443811
Fax: 32-15-443860

Rexnord Kette GmbH
Betzdorf, Germany
Phone: 49-2741-2840
Fax: 49-2741-284-385

LATIN AMERICA

Rexnord International, Inc.
Milwaukee, Wisconsin
Phone: 1-414-643-2366
Fax: 1-414-643-3222
E-mail: international2@rexnord.com

MEXICO

Rexnord S.A. de C.V.
Queretaro, Qro.
Phone: 52-442-218-5000
Fax: 52-442-218-1090

SINGAPORE

Rexnord International, Inc.
Singapore City, Singapore
Phone: 65-6338-5622
Fax: 65-6338-5422

UNITED STATES

Customer Service
Phone: 1-866-REXNORD
(1-866-739-6673)
Fax: 1-614-675-1898
E-mail: [rexnordcs\(state\)@rexnord.com](mailto:rexnordcs(state)@rexnord.com)
Example: rexnordcsohio@rexnord.com

ALL COUNTRIES NOT LISTED

Rexnord International
Milwaukee, Wisconsin
Phone: 1-414-643-2366
Fax: 1-414-643-3222
E-mail: international1@rexnord.com

