



**NATIONAL COMMISSION FOR THE  
CERTIFICATION OF CRANE OPERATORS (NCCCO)**

**RIGGER REFERENCE  
MANUAL**

## **HOLD HARMLESS/RELEASE/DISCLAIMER AGREEMENT**

The reading and/or using person or entities using this publication for and in consideration of the assistance, cooperation, and information given by the National Commission for the Certification of Crane Operators (NCCCO) in this publication, *Rigger Reference Manual*, the receipt of which is acknowledged, does hereby and for all future time have released, hold harmless from any liability, and forever discharged for itself, its administrators and assigns the said NCCCO from all and any manner of action or demands whatsoever in law, in admiralty, or in equity, which against the said NCCCO anyone ever had, now have, or which shall be later claimed. This agreement relates specifically to any cause of action arising out of the publication, information provided, subsequent conduct, and any use of the information provided in this publication

and related uses or demonstrations of skills, methods, and techniques cite in the publication. This mutually beneficial release and hold harmless agreement may not be changed orally, and exists in perpetuity. NCCCO generally and specifically disclaims any warranty, merchantability of intended or unintended use or liability lifting industry and promote public safety.

Copyright 2013 by National Commission for the Certification of Crane Operators. All rights reserved. No part of this book may be reproduced or transmitted in any form or by any means, electronic or mechanical, including photocopying, without prior written permission from the publisher. For information, contact the publisher, National Commission for the Certification of Crane Operators, Inc.



## Preface

This manual has been provided as a reference source for candidates preparing to take the NCCCO Rigger certification exams. NCCCO subject matter experts compiled from a number of sources and selected sections of relevant material for inclusion in the *NCCCO Rigger Reference Manual*. ASME and OSHA granted NCCCO permission for posting and printing selected sections from the following ASME and OSHA standards:

- ASME B30.5 - Mobile and Locomotive Cranes
- ASME B30.10 - Hooks
- ASME B30.20 - Below-the-Hook Lifting Devices
- OSHA 1910.184 - Slings
- OSHA 1926.251 - Rigging Equipment for Material Handling
- OSHA 29 CFR 1926 Subpart CC - Cranes and Derricks in Construction

*Portions reprinted from ASME B30.5, B30.10, ASME B30.20 and ASME B30.23 by permission of The American Society of Mechanical Engineers. All rights reserved.*

The following reference materials, in addition to the references cited above, are used by NCCCO's Examination Committee to verify the accuracy of NCCCO test questions.

- ASME B30.9 - Slings
- ASME B30.26 - Rigging Hardware
- *IPT's Crane and Rigging Training Manual*
- *Rigging for Ironworkers Reference Manual*
- *NCCCO Rigger Reference Booklet*

The material contained herein is not to be used for any other purpose than reference material in association with preparing for the NCCCO exam. No part of this manual is to be copied or used in any manner other than by individual candidates preparing for the NCCCO Rigger examination.

This page intentionally left blank



# Table of Contents

<b>Chapter 1: ASME B30.5-2011 – Mobile and Locomotive Cranes .....</b>	<b>1</b>
Section 5-3.1.3.2: Responsibilities of Site Supervisor and Lift Director.....	3
5-3.1.3.2.1 The site supervisor’s responsibilities shall include the following:.....	3
5-3.1.3.2.2 The lift director’s responsibilities shall include the following: .....	3
<b>Chapter 2: ASME B30.10-2009 – Hooks .....</b>	<b>5</b>
Section 10-1: Selection, Use, and Maintenance.....	7
10-1.8: Identification.....	7
10-1.10.6 Repairs and Modifications .....	7
<b>Chapter 3: ASME B30.20-2010 – Below the Hook Lifting Devices .....</b>	<b>9</b>
Section 20-1: Structural and Mechanical Lifting Devices.....	11
Section 20-1.2: Marking, Construction, and Installation .....	11
Section 20-1.3: Inspection, Testing, and Maintenance.....	11
Section 20-1.4: Operation .....	11
<b>Chapter 4: OSHA 1910.184 – Slings.....</b>	<b>13</b>
Regulations 1910.184.....	15
<b>Chapter 5: OSHA 1926.251 – Rigging Equipment for Material Handling.....</b>	<b>25</b>
Regulations 1926.251 .....	27
§ 1926.251 Rigging Equipment for Material Handling .....	27
<b>Chapter 6: OSHA 29 CFR 1926, Subpart CC – Cranes and Derricks in Construction..</b>	<b>31</b>
Regulations 1926 Subpart CC .....	33
§ 1926.1401 Definitions .....	33
§ 1926.1402 Ground conditions .....	37
§ 1926.1403 Assembly/Disassembly—selection of manufacturer or employer procedures .....	38
§ 1926.1404 Assembly/Disassembly—general requirements (applies to all assembly and disassembly operations) .....	38
§ 1926.1405 Disassembly—additional requirements for dismantling of booms and jibs (applies to both the use of manufacturer procedures and employer procedures) .....	40
§ 1926.1406 Assembly/Disassembly—employer procedures—general requirements .....	40
§ 1926.1407 Power line safety (up to 350 kV)—assembly and disassembly. ....	40
§ 1926.1408 Power line safety (up to 350 kV)—equipment operations .....	41
§ 1926.1409 Power line safety (over 350 kV) .....	44
§ 1926.1410 Power line safety (all voltages)—equipment operations closer than the Table A zone .....	44
§ 1926.1411 Power line safety—while traveling under or near power lines with no load .....	46
§ 1926.1412 Inspections.....	46
§ 1926.1413 Wire rope—inspection. ....	49
§ 1926.1414 Wire rope—selection and installation criteria. ....	51
§ 1926.1415 Safety devices. ....	53
§ 1926.1416 Operational aids. ....	53

§ 1926.1417 Operation. ....	55
§ 1926.1418 Authority to stop operation. ....	57
§ 1926.1419 Signals—general requirements. ....	57
§ 1926.1420 Signals—radio, telephone or other electronic transmission of signals. ....	58
§ 1926.1421 Signals—voice signals— additional requirements. ....	58
§ 1926.1422 Signals—hand signal chart. ....	58
§ 1926.1423 Fall protection. ....	59
§ 1926.1424 Work area control ....	60
§ 1926.1425 Keeping clear of the load ....	61
§ 1926.1425 Keeping clear of the load. ....	61
§ 1926.1426 Free fall and controlled load lowering. ....	62
§ 1926.1427 Operator qualification and certification. ....	62
§ 1926.1428 Signal person qualifications. ....	66
§ 1926.1429 Qualifications of maintenance & repair employees. ....	66
§ 1926.1430 Training. ....	67
§ 1926.1431 Hoisting personnel ....	67
§ 1926.1432 Multiple-crane/derrick lifts— supplemental requirements ....	73
§ 1926.1433 Design, construction and testing. ....	73
§ 1926.1434 Equipment modifications. ....	76
§ 1926.1435 Tower cranes. ....	77
§ 1926.1436 Derricks. ....	80
§ 1926.1437 Floating cranes/derricks and land cranes/derricks on barges. ....	84
§ 1926.1438 Overhead & gantry cranes. ....	88
§ 1926.1439 Dedicated pile drivers. ....	88
§ 1926.1440 Sideboom cranes. ....	88
§ 1926.1441 Equipment with a rated hoisting/lifting capacity of 2,000 pounds or less. ....	89
§ 1926.1442 Severability. ....	90
Appendix A to Subpart CC of Part 1926—Standard Hand Signals ....	91
<b>Chapter 7: Rigger Reference Booklet .....</b>	<b>93</b>



**CHAPTER 1:**  
**ASME B30.5-2011 – Mobile and Locomotive Cranes**

**Section 5-3.1.3.2: Responsibilities of Site Supervisor and Lift Director**

Reprinted from ASME B30.5, by permission of the American Society of Mechanical Engineers. All rights reserved.

This page intentionally left blank





## Section 5-3.1.3.2: Responsibilities of Site Supervisor and Lift Director

### 5-3.1.3.2 Responsibilities of Site Supervisor and Lift Director

#### 5-3.1.3.2.1 The site supervisor's responsibilities shall include the following:

- (a) ensuring that the crane meets the requirements of Chapter 5-2 prior to initial site usage.
- (b) determining if additional regulations are applicable to crane operations.
- (c) ensuring that a qualified person is designated as the lift director.
- (d) ensuring that crane operations are coordinated with other jobsite activities that will be affected by or will affect lift operations.
- (e) ensuring that the area for the crane is adequately prepared. The preparation includes, but is not limited to, the following:
  - (1) access roads for the crane and associated equipment
  - (2) sufficient room to assemble and disassemble the crane
  - (3) an operating area that is suitable for the crane with respect to levelness, surface conditions, support capability, proximity to power lines, excavations, slopes, underground utilities, subsurface construction, and obstructions to crane operation
  - (4) traffic control as necessary to restrict unauthorized access to the crane's working area
- (f) ensuring that work involving the assembly and disassembly of a crane is supervised by a qualified person.
- (g) ensuring that crane operators meet the requirements of para. 5-3.1.2.
- (h) ensuring that conditions that may adversely affect crane operations are addressed. Such conditions include, but are not limited to, the following:
  - (1) poor soil conditions
  - (2) wind velocity or gusting winds
  - (3) heavy rain
  - (4) fog
  - (5) extreme cold
  - (6) artificial lighting
- (i) allowing crane operation near electric power lines only when the requirements of para. 5-3.4.5 have been met.
- (j) permitting special lifting operations only when equipment and procedures required by this Volume, the crane manufacturer, or a qualified person are employed. Such operations include, but are not limited to, the following:
  - (1) multiple crane lifts
  - (2) lifting personnel
  - (3) pick and carry operations
- (k) ensuring that work performed by the rigging crew is supervised by a qualified person.
- (l) ensuring that crane maintenance is performed by a designated person.

#### 5-3.1.3.2.2 The lift director's responsibilities shall include the following:

- (a) being present at the jobsite during lifting operations.
- (b) stopping crane operations if alerted to an unsafe condition affecting those operations.
- (c) ensuring that the preparation of the area needed to support crane operations has been completed before crane operations commence.
- (d) ensuring necessary traffic controls are in place to restrict unauthorized access to the crane's work area
- (e) ensuring that personnel involved in crane operations understand their responsibilities, assigned duties, and the associated hazards.
- (f) addressing safety concerns raised by the operator or other personnel and being responsible if he decides to overrule those concerns and directs crane operations to continue. (In all cases, the manufacturer's criteria for safe operation and the requirements of this Volume shall be adhered to.)
- (g) appointing the signalperson(s) and conveying that information to the crane operator.
- (h) ensuring that signalperson(s) appointed meet the requirements of Section 5-3.3.
- (i) allowing crane operation near electric power lines only when the requirements of para. 5-3.4.5 and any additional requirements determined by the site supervisor have been met.

- (j) ensuring precautions are implemented when hazards associated with special lifting operations are present. Such operations include, but are not limited to, the following:
  - (1) multiple crane lifts
  - (2) lifting personnel
  - (3) pick and carry operations
  - (4) mobile cranes operating on barges
- (k) ensuring that the applicable requirements of ASME B30.23 are met when lifting personnel.
- (l) informing the crane operator of the weight of loads to be lifted, as well as the lifting, moving, and placing locations for these loads.
- (m) obtaining the crane operator's verification that this weight does not exceed the crane's rated capacity.
- (n) ensuring that a crane's load rigging is performed by designated personnel as defined in para. 5-0.2.2.
- (o) ensuring that the load is properly rigged and balanced before it is lifted more than a few inches.



**CHAPTER 2:**  
**ASME B30.10-2009 – Hooks**

**Section 10-1: Selection, Use, and Maintenance**

Reprinted from ASME B30.10, by permission of the American Society of Mechanical Engineers. All rights reserved.

This page intentionally left blank



## Section 10-1: Selection, Use, and Maintenance

### 10-1.8: Identification

Manufacturer's identification and rated load identification shall be forged, cast, or die stamped on a low-stress and non-wearing area of the hook. Alternately, if the hook is used in conjunction with equipment described in other volumes of the B30 Standard, the equipment manufacturer's identification and rated load identification shall be forged, cast, or die stamped on a low-stress and non-wearing area of the hook.

### 10-1.10.6 Repairs and Modifications

- (a) Any conditions disclosed by the inspections performed in accordance with the requirements of para. 10-1.10.3 or 10-1.10.4 shall be corrected by repair or replacement before continuing to use the hook. All repairs and modifications shall be approved by the manufacturer or a qualified person.
- (b) Hooks having damage or wear described as follows shall be repaired or replaced:
  - (1) cracks, nicks, and gouges. Repair of cracks, nicks, and gouges shall be carried out by a designated person by grinding longitudinally, following the contour of the hook, provided no dimension is reduced more than 10% (or as recommended by the manufacturer) of its original value.
  - (2) wear exceeding 10% (or as recommended by the manufacturer) of the original sectional dimension
  - (3) any visibly apparent bend or twist from the plane of the unbent hook
  - (4) any distortion causing an increase in throat opening of 5%, not to exceed 1/4 in. (or as recommended by the manufacturer)
  - (5) inability of self-locking hooks to lock
- (c) A hook latch that is inoperative shall be repaired, replaced, or removed if not required.
- (d) If a required latch is inoperable and cannot be immediately repaired or replaced, the hook shall be sufficiently moused to retain loose items as defined in para. 10-1.3(c) until the latch is repaired or replaced.
- (e) When reassembling shank hooks, original securing methods or manufacturer's recommendations shall be followed.
- (f) All replacement parts shall be at least equal to the original manufacturer's specifications.
- (g) Hooks without provision for latches may be moused to retain loose items as defined in para. 10-1.3(c).
- (h) For special lifting applications where the throat opening is required to be closed, mousing may be used in place of the latch to retain loose items as defined in para. 10-1.3(c), when approved by a qualified person.

This page intentionally left blank



**CHAPTER 3:**  
**ASME B30.20-2010 – Below the Hook  
Lifting Devices**

**Section 20-1: Structural and  
Mechanical Lifting Devices**

Reprinted from ASME B30.20, by permission of the American Society of Mechanical Engineers. All rights reserved.

This page intentionally left blank





# Section 20-1: Structural and Mechanical Lifting Devices

## Section 20-1.2: Marking, Construction, and Installation

### 20-1.2.1 Marking

- (a) *Rated Load.* The rated load of the lifting device shall be legibly marked on the main structure or on a tag attached to it where it is visible. If the lifting device is made up of several lifters, each detachable from the group, these lifters shall also be marked with their individual rated loads.
- (b) *Identification.* All new structural and mechanical lifting devices shall be marked with, but not limited to, the following information:
  - (1) manufacturer's name and address
  - (2) serial number
  - (3) lifter weight, if over 100 lb (45 kg)
  - (4) cold current (amps) (when applicable)
  - (5) rated voltage (when applicable)
  - (6) rated load [as described in para. 20-1.2.1(a)]
  - (7) ASME BTH-1 Design Category
  - (8) ASME BTH-1 Service Class

## Section 20-1.3: Inspection, Testing, and Maintenance

### 20-1.3.2 Every Lift Inspection

Items such as the following shall be inspected by the operator before and/or during every lift for any indication of damage as specifically indicated, including observations during operation for any damage that might occur during the lift:

- (a) surface of the load for debris
- (b) condition and operation of the controls
- (c) condition and operation of the indicators and meters when installed

### 20-1.3.3 Frequent Inspection

Items such as the following shall be inspected for damage at intervals as defined in para. 20-1.3.1(b)(2), including observations during operation for any indications of damage that might appear between inspections. A qualified person shall determine whether any indications of damage constitute a hazard

or will require more frequent inspection. For all lifters, inspect:

- (a) structural members for deformation, cracks, or excessive wear on any part of the lifter
- (b) loose or missing guards, fasteners, covers, stops, or nameplates
- (c) all functional operating mechanisms and automatic hold-and-release mechanisms for misadjustments interfering with operation

## Section 20-1.4: Operation

### 20-1.4.1 Operators

Below-the-hook lifting devices shall be operated only by trained, designated persons.

### 20-1.4.2 Qualifications

Qualifications for operators of below-the-hook lifting devices are as follows:

- (a) The operator shall be instructed in the use of the device by a designated person. Instructions should include, but not be limited to, the following:
  - (1) application of the lifter to the load and adjustments, if any, that adapt the lifter to various sizes or kinds of loads
  - (2) instructions in any special operations or precautions
  - (3) the manufacturer's suggested operating procedures
  - (4) condition of the load itself required for operation of the lifter, such as, but not limited to, balance, surface cleanliness, flatness, bending, and load thickness
  - (5) storage of the lifter to protect it from damage
  - (6) not exceeding the rated load of the lifting device nor the capacity of the hoisting equipment by the combined weight of the load, the lifting device, and rigging
  - (7) the proper attachment of adapters to lifting device for special load handling
- (b) The operator shall demonstrate the ability to operate the lifter as instructed before assuming responsibility for using the lifter.

### 20-1.4.3 Conduct of Lifting Device Operators

- (a) The operator shall give attention to the operation of the lifts during a lifting sequence.
- (b) When physically or otherwise unfit, an operator shall not engage in the operation of the equipment.
- (c) Operators shall be responsible for those operations under their direct control. Whenever there is any doubt as to safety, the operator shall consult a designated person before handling the load.
- (d) The operator shall respond only to instructions from designated persons. However, the operator shall obey a stop order at all times, no matter who gives it.
- (e) The operation of the lifter shall be observed before use and during a shift. Any deficiency observed shall be carefully examined by a designated person. If the deficiency constitutes a hazard, the lifter shall be removed from service and tagged "Out of Service." Any indication of a hazardous condition shall be reported to a qualified person for evaluation.
- (f) The operator shall be familiar with standard hand signals when applicable.
- (g) The operator shall land any attached load and store the lifter before leaving the lifting device.
- (h) All controls shall be tested by the operator before use during a shift. If any controls do not operate properly, they should be adjusted or repaired before operations are begun.
- (i) The operator shall not ride, or allow others to ride, loads or the lifting device.
- (j) The operator and other personnel shall stay clear of the load.

### 20-1.4.4 Lifting Device Operating Practices

- (a) Lifting devices shall be operated only by the following qualified personnel:
  - (1) designated persons
  - (2) trainees under the direct supervision of a designated person
  - (3) maintenance and test personnel, when it is necessary in the performance of their duties
  - (4) inspectors (lifting devices)
- (b) The lifting device shall not be loaded in excess of its rated load or handle any load for which it is not designed.
- (c) The lifter shall be applied to the load in accordance with the instruction manual.
- (d) Before lifting, the operator shall make sure that lifter ropes or chains are not kinked, and that multiple part lines are not twisted around each other.

- (e) Care should be taken to make certain the load is correctly distributed for the lifter being used.
- (f) The temperature of the load should not exceed the maximum allowable limits of the lifter.
- (g) The lifter shall be brought over the load in such a manner as to minimize swinging.
- (h) Care shall be taken that there is not sudden acceleration or deceleration of the load.
- (i) Do not allow load or lifter to come into contact with any obstruction.
- (j) The operator shall avoid carrying the load over people.
- (k) The lifter shall not be used for side pulls or sliding the load unless specifically authorized by a qualified person.
- (l) The operator shall not leave suspended loads unattended.

### 20-1.4.5 Miscellaneous Operating Practices

- (a) An operator shall not use a lifting device that is tagged "Out of Service" or otherwise designated as non-functioning.
- (b) "Out of Service" tags on lifting devices shall not be removed without the approval of the person placing them or an authorized person.
- (c) The lifter, when not in use, should be stored at an assigned location.
- (d) Caution should be taken that operating markings or tags shall not be removed or defaced. Missing or illegible markings or tags shall be replaced.

### 20-1.5 Instruction Manuals

Operating instructions and maintenance and parts information shall be furnished by the manufacturer.



**CHAPTER 4:**  
**OSHA 1910.184 – Slings**

**OSHA 1910.184 – Slings**

Reprinted from Occupational Safety and Health Administration (OSHA) standard. All rights reserved.

This page intentionally left blank



# OSHA 1910.184 – Slings

## Regulations 1910.184

- Part Number: 1910
- Part Title: Occupational Safety and Health Standards
- Subpart: N
- Subpart Title: Materials Handling and Storage
- Standard Number: 1910.184
- Title: Slings

## § 1910.184 Slings

(a) **Scope.** This section applies to slings used in conjunction with other material handling equipment for the movement of material by hoisting, in employments covered by this part. The types of slings covered are those made from alloy steel chain, wire rope, metal mesh, natural or synthetic fiber rope (conventional three strand construction), and synthetic web (nylon, polyester, and polypropylene).

### (b) **Definitions.**

**Angle of loading** is the inclination of a leg or branch of a sling measured from the horizontal or vertical plane as shown in *Fig. N-184-5*; provided that an angle of loading of five degrees or less from the vertical may be considered a vertical angle of loading.

**Basket hitch** is a sling configuration whereby the sling is passed under the load and has both ends, end attachments, eyes or handles on the hook or a single master link.

**Braided wire rope** is a wire rope formed by plaiting component wire ropes.

**Bridle wire rope sling** is a sling composed of multiple wire rope legs with the top ends gathered in a fitting that goes over the lifting hook.

**Cable laid endless sling—mechanical joint** is a wire rope sling made endless by joining the ends of a single length of cable laid rope with one or more metallic fittings.

**Cable laid grommet—hand tucked** is an endless wire rope sling made from one length of rope wrapped six times around a core formed by

hand tucking the ends of the rope inside the six wraps.

**Cable laid rope** is a wire rope composed of six wire ropes wrapped around a fiber or wire rope core.

**Cable laid rope sling—mechanical joint** is a wire rope sling made from a cable laid rope with eyes fabricated by pressing or swaging one or more metal sleeves over the rope junction.

**Choker hitch** is a sling configuration with one end of the sling passing under the load and through an end attachment, handle or eye on the other end of the sling.

**Coating** is an elastomer or other suitable material applied to a sling or to a sling component to impart desirable properties.

**Cross rod** is a wire used to join spirals of metal mesh to form a complete fabric. (*See Fig. N-184-2.*)

**Designated** means selected or assigned by the employer or the employer's representative as being qualified to perform specific duties.

**Equivalent entity** is a person or organization (including an employer) which, by possession of equipment, technical knowledge and skills, can perform with equal competence the same repairs and tests as the person or organization with which it is equated.

**Fabric (metal mesh)** is the flexible portion of a metal mesh sling consisting of a series of transverse coils and cross rods.

**Female handle (choker)** is a handle with a handle eye and a slot of such dimension as to permit passage of a male handle thereby allowing the use of a metal mesh sling in a choker hitch. (*See Fig. N-184-1.*)

**Handle** is a terminal fitting to which metal mesh fabric is attached. (*See Fig. N-184-1.*)

**Handle eye** is an opening in a handle of a metal mesh sling shaped to accept a hook, shackle or other lifting device. (*See Fig. N-184-1.*)

**Hitch** is a sling configuration whereby the sling is fastened to an object or load, either directly to it or around it.

**Link** is a single ring of a chain.

**Male handle (triangle)** is a handle with a handle eye.

*Master coupling link* is an alloy steel welded coupling link used as an intermediate link to join alloy steel chain to master links. (See Fig. N-184-3.)

*Master link* or *gathering ring* is a forged or welded steel link used to support all members (legs) of an alloy steel chain sling or wire rope sling. (See Fig. N-184-3.)

*Mechanical coupling link* is a non-welded, mechanically closed steel link used to attach master links, hooks, etc., to alloy steel chain.

*Proof load* is the load applied in performance of a proof test.

*Proof test* is a nondestructive tension test performed by the sling manufacturer or an equivalent entity to verify construction and workmanship of a sling.

*Rated capacity* or *working load limit* is the maximum working load permitted by the provisions of this section.

*Reach* is the effective length of an alloy steel chain sling measured from the top bearing surface of the upper terminal component to the bottom bearing surface of the lower terminal component.

*Selvage edge* is the finished edge of synthetic webbing designed to prevent unraveling.

*Sling* is an assembly which connects the load to the material handling equipment.

*Sling manufacturer* is a person or organization that assembles sling components into their final form for sale to users.

*Spiral* is a single transverse coil that is the basic element from which metal mesh is fabricated. (See Fig. N-184-2.)

*Strand laid endless sling—mechanical joint* is a wire rope sling made endless from one length of rope with the ends joined by one or more metallic fittings.

*Strand laid grommet—hand tucked* is an endless wire rope sling made from one length of strand wrapped six times around a core formed by hand tucking the ends of the strand inside the six wraps.

*Strand laid rope* is a wire rope made with strands (usually six or eight) wrapped around a fiber core, wire strand core, or independent wire rope core (IWRC).

*Vertical hitch* is a method of supporting a load by a single, vertical part or leg of the sling. (See Fig. N-184-4.)

- (c) **Safe operating practices.** Whenever any sling is used, the following practices shall be observed:
- (1) Slings that are damaged or defective shall not be used.
  - (2) Slings shall not be shortened with knots or bolts or other makeshift devices.
  - (3) Sling legs shall not be kinked.
  - (4) Slings shall not be loaded in excess of their rated capacities.
  - (5) Slings used in a basket hitch shall have the loads balanced to prevent slippage.
  - (6) Slings shall be securely attached to their loads.
  - (7) Slings shall be padded or protected from the sharp edges of their loads.
  - (8) Suspended loads shall be kept clear of all obstructions.
  - (9) All employees shall be kept clear of loads about to be lifted and of suspended loads.
  - (10) Hands or fingers shall not be placed between the sling and its load while the sling is being tightened around the load.
  - (11) Shock loading is prohibited.
  - (12) A sling shall not be pulled from under a load when the load is resting on the sling.
  - (13) Employers must not load a sling in excess of its recommended safe working load as prescribed by the sling manufacturer on the identification markings permanently affixed to the sling.
  - (14) Employers must not use slings without affixed and legible identification markings.
- (d) **Inspections.** Each day before being used, the sling and all fastenings and attachments shall be inspected for damage or defects by a competent person designated by the employer. Additional inspections shall be performed during sling use, where service conditions warrant. Damaged or defective slings shall be immediately removed from service.
- (e) **Alloy steel chain slings.**
- (1) **Sling identification.** Alloy steel chain slings shall have permanently affixed durable identification stating size, grade, rated capacity, and reach.
  - (2) **Attachments.**
    - (i) Hooks, rings, oblong links, pear shaped links, welded or mechanical coupling links or other attachments shall have a rated capacity at least equal to that of the alloy steel chain with which they are used or the sling shall not be used in excess of the rated capacity of the weakest component.

- (ii) Makeshift links or fasteners formed from bolts or rods, or other such attachments, shall not be used.
- (3) *Inspections.*
  - (i) In addition to the inspection required by paragraph (d) of this section, a thorough periodic inspection of alloy steel chain slings in use shall be made on a regular basis, to be determined on the basis of (A) frequency of sling use; (B) severity of service conditions; (C) nature of lifts being made; and (D) experience gained on the service life of slings used in similar circumstances. Such inspections shall in no event be at intervals greater than once every 12 months.
  - (ii) The employer shall make and maintain a record of the most recent month in which each alloy steel chain sling was thoroughly inspected, and shall make such record available for examination.
  - (iii) The thorough inspection of alloy steel chain slings shall be performed by a competent person designated by the employer, and shall include a thorough inspection for wear, defective welds, deformation and increase in length. Where such defects or deterioration are present, the sling shall be immediately removed from service.
- (4) *Proof testing.* The employer shall ensure that before use, each new, repaired, or reconditioned alloy steel chain sling, including all welded components in the sling assembly, shall be proof tested by the sling manufacturer or equivalent entity, in accordance with paragraph 5.2 of the American Society of Testing and Materials Specification A391-65, which is incorporated by reference as specified in Sec. 1910.6 (ANSI G61.1-1968). The employer shall retain a certificate of the proof test and shall make it available for examination.
- (5) [Reserved]
- (6) *Safe operating temperatures.* Employers must permanently remove an alloy steel-chain slings from service if it is heated above 1000 degrees F. When exposed to service temperatures in excess of 600 degrees F, employers must reduce the maximum working-load limits permitted by the chain manufacturer in accordance with the chain or sling manufacturer's recommendations.
- (7) *Repairing and reconditioning alloy steel chain slings.*
  - (i) Worn or damaged alloy steel chain slings or attachments shall not be used until repaired. When welding or heat testing is performed, slings shall not be used unless repaired,

reconditioned and proof tested by the sling manufacturer or an equivalent entity.

- (ii) Mechanical coupling links or low carbon steel repair links shall not be used to repair broken lengths of chain.
- (8) *Effects of wear.* If the chain size at any point of any link is less than that stated in Table N-184-1, the sling shall be removed from service.

**TABLE N-184-1.  
MINIMUM ALLOWABLE CHAIN SIZE  
AT ANY POINT OF LINK**

Chain size, inches	Minimum allowable chain size, inches
1/4	13/64
3/8	19/64
1/2	25/64
5/8	31/64
3/4	19/32
7/8	45/64
1	13/16
1 1/8	29/32
1 1/4	1
1 3/8	1 3/32
1 1/2	1 3/16
1 3/4	1 13/32

- (9) *Deformed attachments.*
  - (i) Alloy steel chain slings with cracked or deformed master links, coupling links or other components shall be removed from service.
  - (ii) Slings shall be removed from service if hooks are cracked, have been opened more than 15 percent of the normal throat opening measured at the narrowest point or twisted more than 10 degrees from the plane of the unbent hook.
- (f) *Wire rope slings.*
  - (1) *Sling use.* Employers must use only wire-rope slings that have permanently affixed and legible identification markings as prescribed by the manufacturer, and that indicate the recommended safe working load for the type(s) of hitch(es) used, the angle upon which it is based, and the number of legs if more than one.
  - (2) *Minimum sling lengths.*
    - (i) Cable laid and 6x19 and 6x37 slings shall have a minimum clear length of wire rope 10 times the component rope diameter between splices, sleeves or end fittings.
    - (ii) Braided slings shall have a minimum clear length of wire rope 40 times the component

- rope diameter between the loops or end fittings.
- (iii) Cable laid grommets, strand laid grommets and endless slings shall have a minimum circumferential length of 96 times their body diameter.
- (3) *Safe operating temperatures.* Fiber core wire rope slings of all grades shall be permanently removed from service if they are exposed to temperatures in excess of 200 deg. F. When nonfiber core wire rope slings of any grade are used at temperatures above 400 deg. F or below minus 60 deg. F, recommendations of the sling manufacturer regarding use at that temperature shall be followed.
- (4) *End attachments.*
- (i) Welding of end attachments, except covers to thimbles, shall be performed prior to the assembly of the sling.
- (ii) All welded end attachments shall not be used unless proof tested by the manufacturer or equivalent entity at twice their rated capacity prior to initial use. The employer shall retain a certificate of the proof test, and make it available for examination.
- (5) *Removal from service.* Wire rope slings shall be immediately removed from service if any of the following conditions are present:
- (i) Ten randomly distributed broken wires in one rope lay, or five broken wires in one strand in one rope lay.
- (ii) Wear or scraping of one-third the original diameter of outside individual wires.
- (iii) Kinking, crushing, bird caging or any other damage resulting in distortion of the wire rope structure.
- (iv) Evidence of heat damage.
- (v) End attachments that are cracked, deformed or worn.
- (vi) Hooks that have been opened more than 15 percent of the normal throat opening measured at the narrowest point or twisted more than 10 degrees from the plane of the unbent hook.
- (vii) Corrosion of the rope or end attachments.
- (g) *Metal mesh slings.*
- (1) *Sling marking.* Each metal mesh sling shall have permanently affixed to it a durable marking that states the rated capacity for vertical basket hitch and choker hitch loadings.
- (2) *Handles.* Handles shall have a rated capacity at least equal to the metal fabric and exhibit no deformation after proof testing.
- (3) *Attachments of handles to fabric.* The fabric and handles shall be joined so that:
- (i) The rated capacity of the sling is not reduced.
- (ii) The load is evenly distributed across the width of the fabric.
- (iii) Sharp edges will not damage the fabric.
- (4) *Sling coatings.* Coatings which diminish the rated capacity of a sling shall not be applied.
- (5) *Sling testing.* All new and repaired metal mesh slings, including handles, shall not be used unless proof tested by the manufacturer or equivalent entity at a minimum of 1 1/2 times their rated capacity. Elastomer impregnated slings shall be proof tested before coating.
- (6) [Reserved]
- (7) *Safe operating temperatures.* Metal mesh slings which are not impregnated with elastomers may be used in a temperature range from minus 20 deg. F to plus 550 deg. F without decreasing the working load limit. Metal mesh slings impregnated with polyvinyl chloride or neoprene may be used only in a temperature range from zero degrees to plus 200 deg. F. For operations outside these temperature ranges or for metal mesh slings impregnated with other materials, the sling manufacturer's recommendations shall be followed.
- (8) *Repairs.*
- (i) Metal mesh slings which are repaired shall not be used unless repaired by a metal mesh sling manufacturer or an equivalent entity.
- (ii) Once repaired, each sling shall be permanently marked or tagged, or a written record maintained, to indicate the date and nature of the repairs and the person or organization that performed the repairs. Records of repairs shall be made available for examination.
- (9) *Removal from service.* Metal mesh slings shall be immediately removed from service if any of the following conditions are present:
- (i) A broken weld or broken brazed joint along the sling edge.
- (ii) Reduction in wire diameter of 25 percent due to abrasion or 15 percent due to corrosion.
- (iii) Lack of flexibility due to distortion of the fabric.
- (iv) Distortion of the female handle so that the depth of the slot is increased more than 10 percent.
- (v) Distortion of either handle so that the width of the eye is decreased more than 10 percent.
- (vi) A 15 percent reduction of the original cross sectional area of metal at any point around the handle eye.
- (vii) Distortion of either handle out of its plane.



(h) **Natural and synthetic fiber rope slings.**

- (1) **Sling use.** Employers must use natural and synthetic fiber-rope slings that have permanently affixed and legible identification markings stating the rated capacity for the type(s) of hitch(es) used and the angle upon which it is based, type of fiber material, and the number of legs if more than one. (See Fig. N-184-4 and Fig. N-184-5.)
- (2) **Safe operating temperatures.** Natural and synthetic fiber rope slings, except for wet frozen slings, may be used in a temperature range from minus 20 deg. F to plus 180 deg. F without decreasing the working load limit. For operations outside this temperature range and for wet frozen slings, the sling manufacturer's recommendations shall be followed.
- (3) **Splicing.** Spliced fiber rope slings shall not be used unless they have been spliced in accordance with the following minimum requirements and in accordance with any additional recommendations of the manufacturer:
  - (i) In manila rope, eye splices shall consist of at least three full tucks, and short splices shall consist of at least six full tucks, three on each side of the splice center line.
  - (ii) In synthetic fiber rope, eye splices shall consist of at least four full tucks, and short splices shall consist of at least eight full tucks, four on each side of the center line.
  - (iii) Strand end tails shall not be trimmed flush with the surface of the rope immediately adjacent to the full tucks. This applies to all types of fiber rope and both eye and short splices. For fiber rope under one inch in diameter, the tail shall project at least six rope diameters beyond the last full tuck. For fiber rope one inch in diameter and larger, the tail shall project at least six inches beyond the last full tuck. Where a projecting tail interferes with the use of the sling, the tail shall be tapered and spliced into the body of the rope using at least two additional tucks (which will require a tail length of approximately six rope diameters beyond the last full tuck).
  - (iv) Fiber rope slings shall have a minimum clear length of rope between eye splices equal to 10 times the rope diameter.
  - (v) Knots shall not be used in lieu of splices.
  - (vi) Clamps not designed specifically for fiber ropes shall not be used for splicing.
  - (vii) For all eye splices, the eye shall be of such size to provide an included angle of not greater than 60 degrees at the splice when the eye is placed over the load or support.
- (4) **End attachments.** Fiber rope slings shall not be used if end attachments in contact with the rope have sharp edges or projections.
- (5) **Removal from service.** Natural and synthetic fiber rope slings shall be immediately removed from service if any of the following conditions are present:
  - (i) Abnormal wear.
  - (ii) Powdered fiber between strands.
  - (iii) Broken or cut fibers.
  - (iv) Variations in the size or roundness of strands.
  - (v) Discoloration or rotting.
  - (vi) Distortion of hardware in the sling.
- (6) **Repairs.** Only fiber rope slings made from new rope shall be used. Use of repaired or reconditioned fiber rope slings is prohibited.
- (i) **Synthetic web slings --**
  - (1) **Sling identification.** Each sling shall be marked or coded to show the rated capacities for each type of hitch and type of synthetic web material.
  - (2) **Webbing.** Synthetic webbing shall be of uniform thickness and width and selvage edges shall not be split from the webbing's width.
  - (3) **Fittings.** Fittings shall be:
    - (i) Of a minimum breaking strength equal to that of the sling; and
    - (ii) Free of all sharp edges that could in any way damage the webbing.
  - (4) Attachment of end fittings to webbing and formation of eyes. Stitching shall be the only method used to attach end fittings to webbing and to form eyes. The thread shall be in an even pattern and contain a sufficient number of stitches to develop the full breaking strength of the sling.
  - (5) [Reserved]
  - (6) **Environmental conditions.** When synthetic web slings are used, the following precautions shall be taken:
    - (i) Nylon web slings shall not be used where fumes, vapors, sprays, mists or liquids of acids or phenolics are present.
    - (ii) Polyester and polypropylene web slings shall not be used where fumes, vapors, sprays, mists or liquids of caustics are present.
    - (iii) Web slings with aluminum fittings shall not be used where fumes, vapors, sprays, mists or liquids of caustics are present. (See Fig. N-184-6.)
  - (7) **Safe operating temperatures.** Synthetic web slings of polyester and nylon shall not be used at temperatures in excess of 180 deg. F. Polypropylene web slings shall not be used at temperatures in excess of 200 deg. F.

(8) *Repairs.*

- (i) Synthetic web slings which are repaired shall not be used unless repaired by a sling manufacturer or an equivalent entity.
- (ii) Each repaired sling shall be proof tested by the manufacturer or equivalent entity to twice the rated capacity prior to its return to service. The employer shall retain a certificate of the proof test and make it available for examination.
- (iii) Slings, including webbing and fittings, which have been repaired in a temporary manner shall not be used.

(9) *Removal from service.* Synthetic web slings shall be immediately removed from service if any of the following conditions are present:

- (i) Acid or caustic burns;
- (ii) Melting or charring of any part of the sling surface;
- (iii) Snags, punctures, tears or cuts;
- (iv) Broken or worn stitches; or
- (v) Distortion of fittings.

FIGURE N-184-1 METAL MESH SLING (TYPICAL)

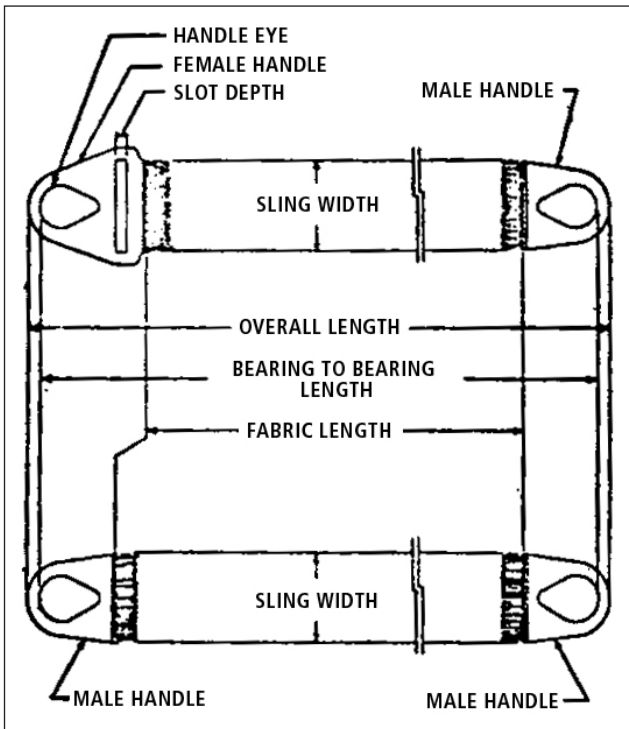

FIGURE N-184-2 METAL MESH CONSTRUCTION

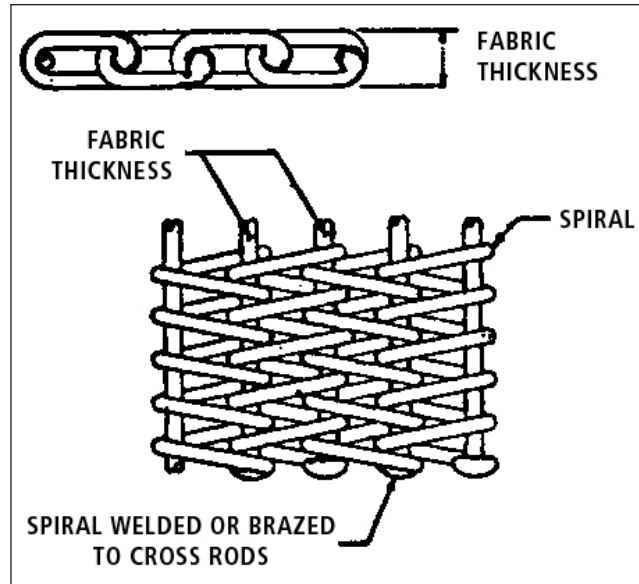

FIGURE N-184-3 MAJOR COMPONENTS OF A QUADRUPLE SLING

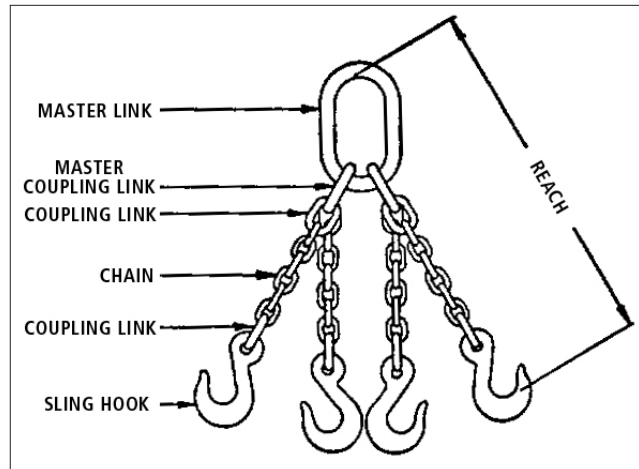

FIGURE N-184-4 BASIC SLING CONFIGURATIONS WITH VERTICAL LEGS

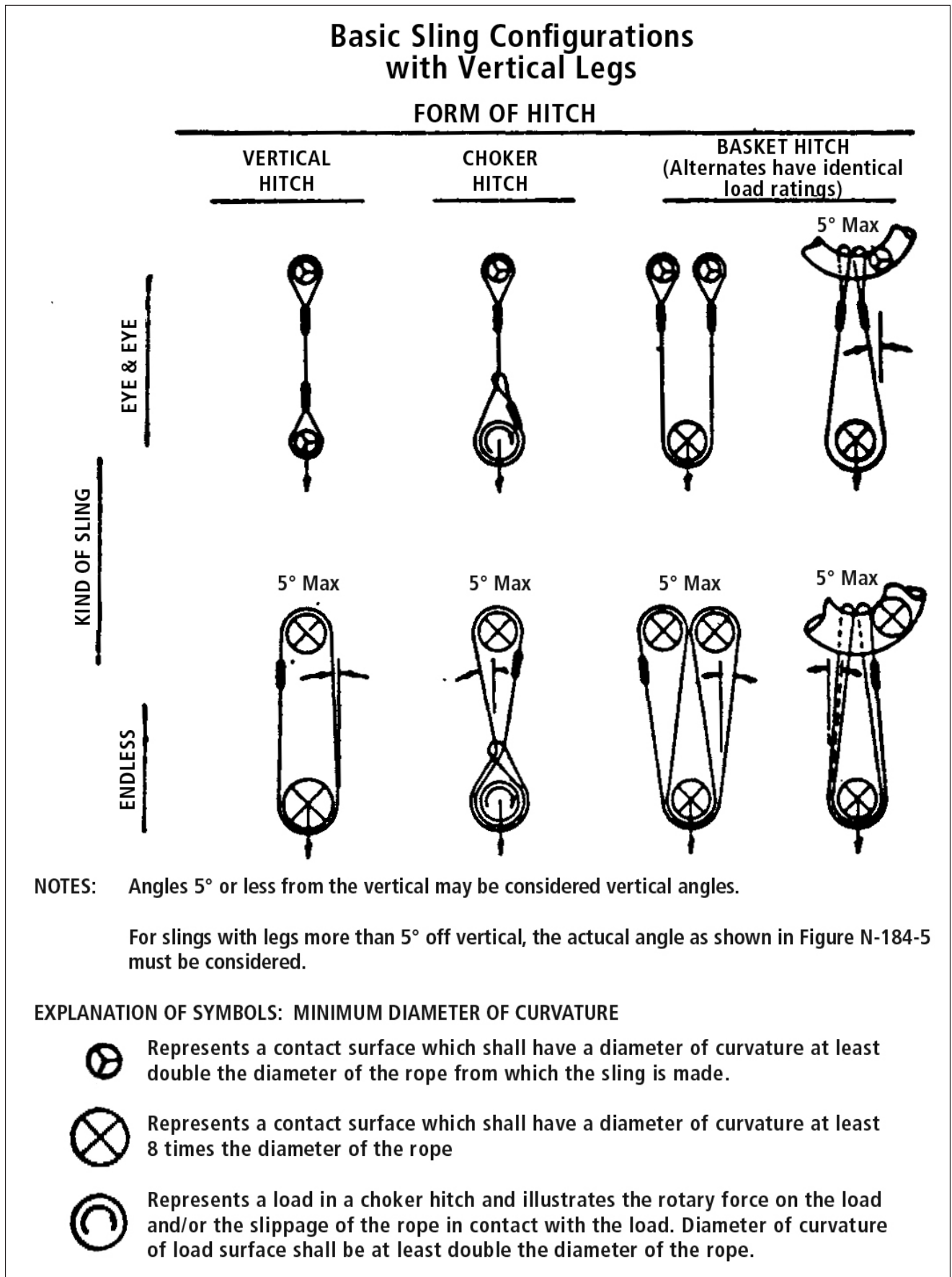

FIGURE N-184-5 SLING CONFIGURATIONS WITH ANGLED LEGS

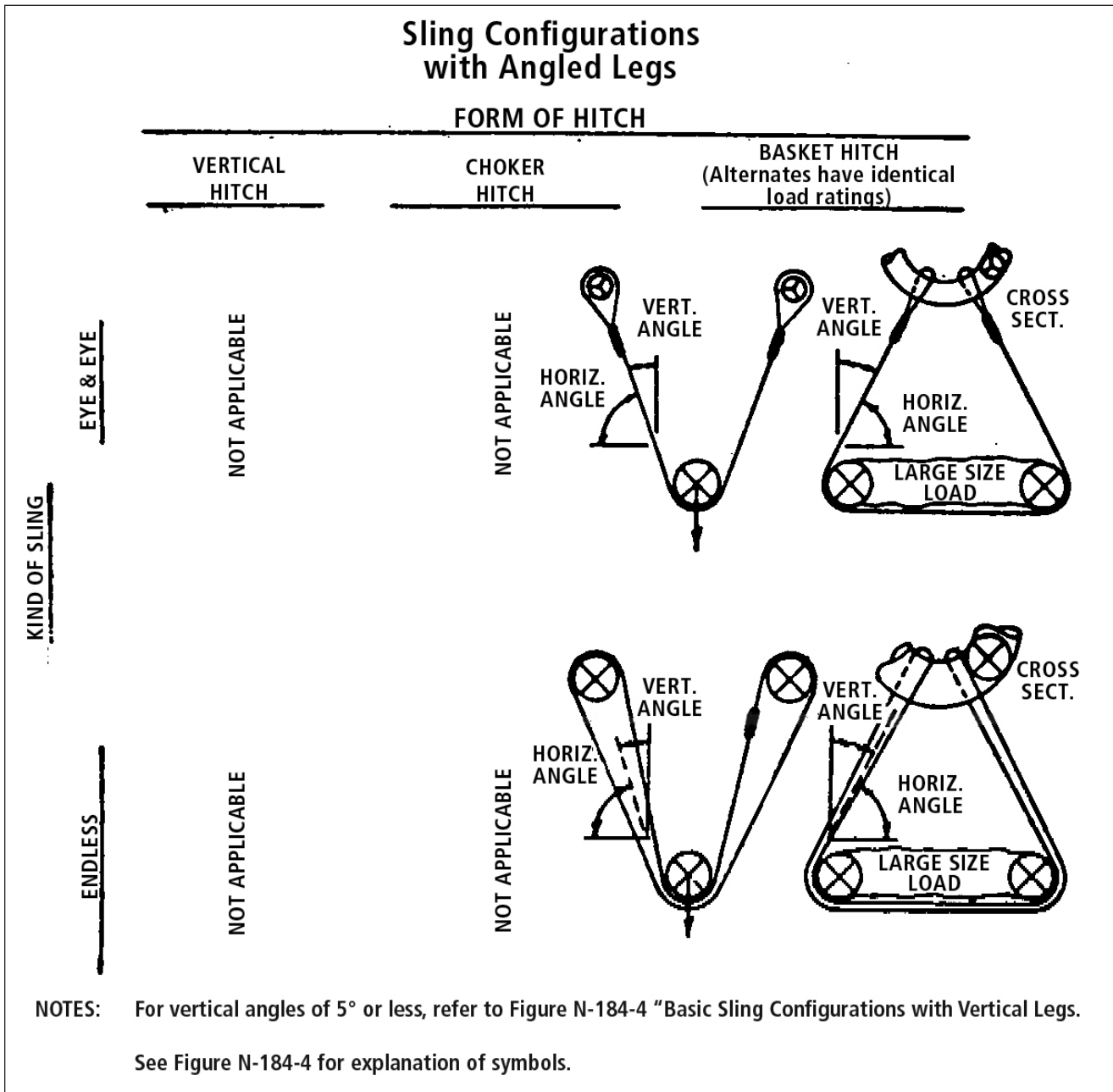
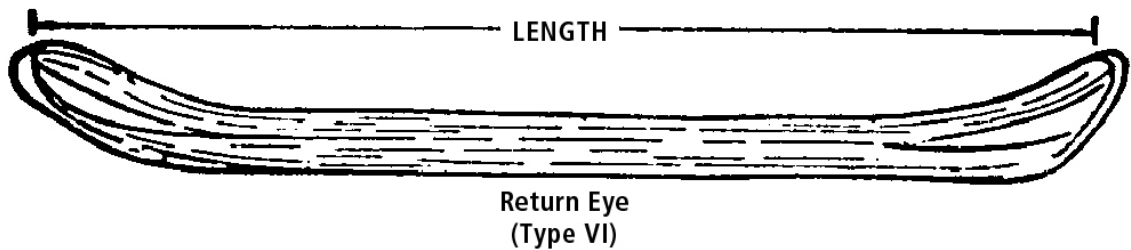
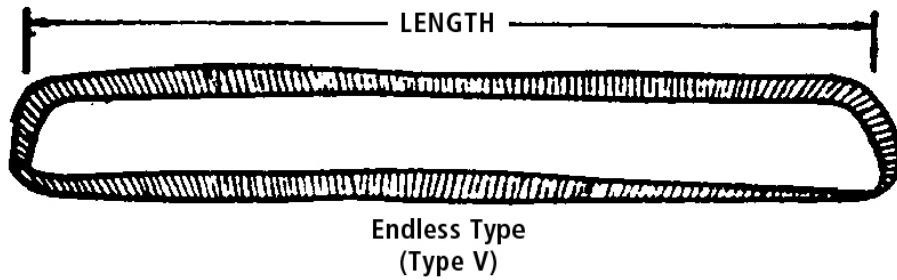
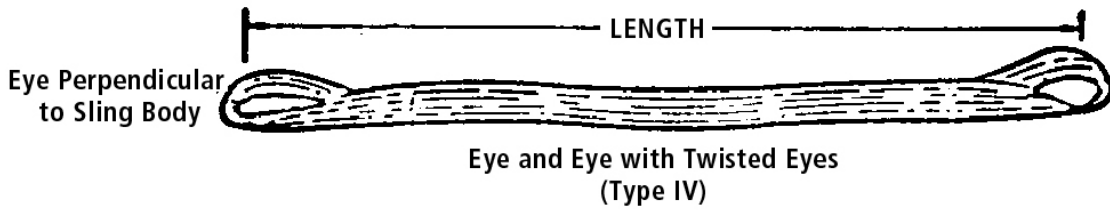
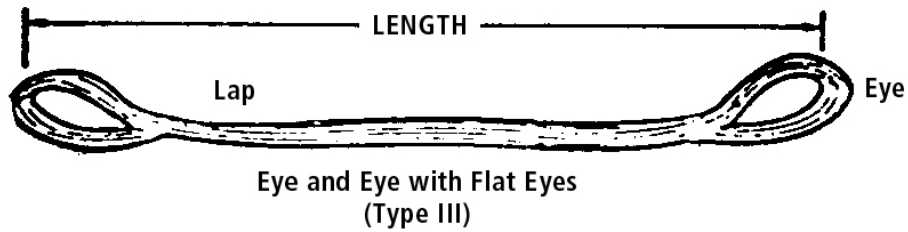
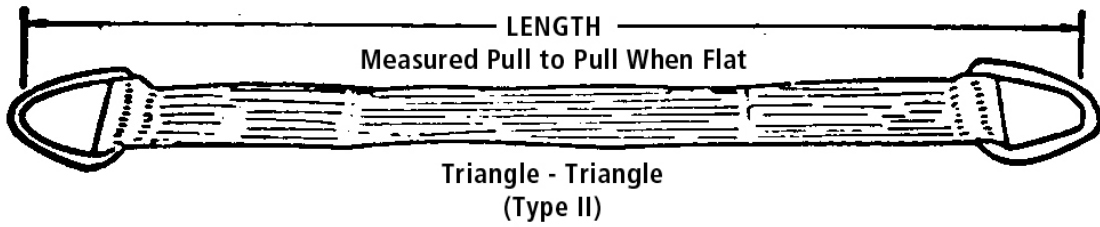
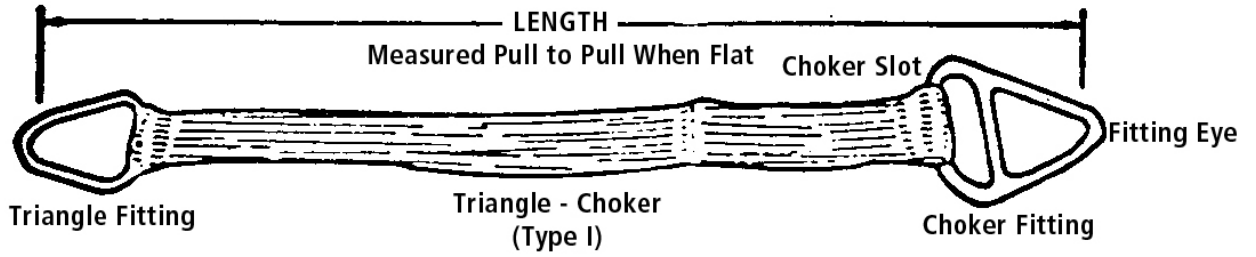

FIGURE N-184-6 BASIC SYNTHETIC WEB SLING CONSTRUCTIONS

### Basic Synthetic Web Sling Constructions



This page intentionally left blank



**CHAPTER 5:**

**OSHA 1926.251 – Rigging Equipment for Material Handling**

**OSHA 1926.251 – Rigging Equipment for Material Handling**

Reprinted from Occupational Safety and Health Administration (OSHA) standard. All rights reserved.

This page intentionally left blank





# OSHA 1926.251 – Rigging Equipment for Material Handling

## Regulations 1926.251

- Part Number: 1926
- Part Title: Occupational Safety and Health Standards
- Subpart: H
- Subpart Title: Materials Handling, Storage, Use, and Disposal
- Standard Number: 1926.251
- Title: Rigging equipment for material handling
- Applicable Standards: 1910.184(a); 1910.184(c)(2); 1910.184(c)(3); 1910.184(c)(5); 1910.184(c)(7); 1910.184(c)(10); 1910.184(c)(11); 1910.184(c)(12); 1910.184(f)(2); 1910.184(f)(3); 1910.184(f)(4); 1910.184(d)

## § 1926.251 Rigging Equipment for Material Handling

### (a) General.

- (1) Rigging equipment for material handling shall be inspected prior to use on each shift and as necessary during its use to ensure that it is safe. Defective rigging equipment shall be removed from service.
- (2) Employers must ensure that rigging equipment:
  - (i) Has permanently affixed and legible identification markings as prescribed by the manufacturer that indicate the recommended safe working load;
  - (ii) Not be loaded in excess of its recommended safe working load as prescribed on the identification markings by the manufacturer; and
  - (iii) Not be used without affixed, legible identification markings, required by paragraph (a)(2)(i) of this section.
- (3) Rigging equipment, when not in use, shall be removed from the immediate work area so as not to present a hazard to employees.
- (4) Special custom design grabs, hooks, clamps, or other lifting accessories, for such units as modular panels, prefabricated structures and similar materials, shall be marked to indicate the safe working loads and shall be proof-tested prior to use to 125 percent of their rated load.

(5) “Scope.” This section applies to slings used in conjunction with other material handling equipment for the movement of material by hoisting, in employments covered by this part. The types of slings covered are those made from alloy steel chain, wire rope, metal mesh, natural or synthetic fiber rope (conventional three strand construction), and synthetic web (nylon, polyester, and polypropylene).

(6) “Inspections.” Each day before being used, the sling and all fastenings and attachments shall be inspected for damage or defects by a competent person designated by the employer. Additional inspections shall be performed during sling use, where service conditions warrant. Damaged or defective slings shall be immediately removed from service.

### (b) Alloy steel chains.

- (1) Welded alloy steel chain slings shall have permanently affixed durable identification stating size, grade, rated capacity, and sling manufacturer.
- (2) Hooks, rings, oblong links, pear-shaped links, welded or mechanical coupling links, or other attachments, when used with alloy steel chains, shall have a rated capacity at least equal to that of the chain.
- (3) Job or shop hooks and links, or makeshift fasteners, formed from bolts, rods, etc., or other such attachments, shall not be used.
- (4) Employers must not use alloy steel-chain slings with loads in excess of the rated capacities (i.e., working load limits) indicated on the sling by permanently affixed and legible identification markings prescribed by the manufacturer.
- (5) Whenever wear at any point of any chain link exceeds that shown in Table H-1, the assembly shall be removed from service.
- (6) “Inspections.”
  - (i) In addition to the inspection required by other paragraphs of this section, a thorough periodic inspection of alloy steel chain slings in use shall be made on a regular basis, to be determined on the basis of (A) frequency of sling use; (B) severity of service conditions; (C) nature of lifts being made; and (D) experience gained on the service life of slings used in similar circumstances. Such inspections

shall in no event be at intervals greater than once every 12 months.

- (ii) The employer shall make and maintain a record of the most recent month in which each alloy steel chain sling was thoroughly inspected, and shall make such record available for examination.

(c) Wire rope.

- (1) Employers must not use improved plow-steel wire rope and wire-rope slings with loads in excess of the rated capacities (i.e., working load limits) indicated on the sling by permanently affixed and legible identification markings prescribed by the manufacturer.
- (2) Protruding ends of strands in splices on slings and bridles shall be covered or blunted.
- (3) Wire rope shall not be secured by knots, except on haul back lines on scrapers.
- (4) The following limitations shall apply to the use of wire rope:
  - (i) An eye splice made in any wire rope shall have not less than three full tucks. However, this requirement shall not operate to preclude the use of another form of splice or connection which can be shown to be as efficient and which is not otherwise prohibited.
  - (ii) Except for eye splices in the ends of wires and for endless rope slings, each wire rope used in hoisting or lowering, or in pulling loads, shall consist of one continuous piece without knot or splice.
  - (iii) Eyes in wire rope bridles, slings, or bull wires shall not be formed by wire rope clips or knots.
  - (iv) Wire rope shall not be used if, in any length of eight diameters, the total number of visible broken wires exceeds 10 percent of the total number of wires, or if the rope shows other signs of excessive wear, corrosion, or defect.
- (5) When U-bolt wire rope clips are used to form eyes, Table H-2 shall be used to determine the number and spacing of clips.
  - (i) When used for eye splices, the U-bolt shall be applied so that the “U” section is in contact with the dead end of the rope.
  - (ii) [Reserved]
- (6) Slings shall not be shortened with knots or bolts or other makeshift devices.
- (7) Sling legs shall not be kinked.
- (8) Slings used in a basket hitch shall have the loads balanced to prevent slippage.
- (9) Slings shall be padded or protected from the sharp edges of their loads.

- (10) Hands or fingers shall not be placed between the sling and its load while the sling is being tightened around the load.

- (11) Shock loading is prohibited.

- (12) A sling shall not be pulled from under a load when the load is resting on the sling.

- (13) “Minimum sling lengths.”

- (i) Cable laid and 6 X 19 and 6 X 37 slings shall have minimum clear length of wire rope 10 times the component rope diameter between splices, sleeves or end fittings.

- (ii) Braided slings shall have a minimum clear length of wire rope 40 times the component rope diameter between the loops or end fittings.

- (iii) Cable laid grommets, strand laid grommets and endless slings shall have a minimum circumferential length of 96 times their body diameter.

- (14) “Safe operating temperatures.” Fiber core wire rope slings of all grades shall be permanently removed from service if they are exposed to temperatures in excess of 200 deg. F (93.33 deg. C). When nonfiber core wire rope slings of any grade are used at temperatures above 400 deg. F (204.44 deg. C) or below minus 60 deg. F (15.55 deg. C), recommendations of the sling manufacturer regarding use at that temperature shall be followed.

- (15) “End attachments.”

- (i) Welding of end attachments, except covers to thimbles, shall be performed prior to the assembly of the sling.

- (ii) All welded end attachments shall not be used unless proof tested by the manufacturer or equivalent entity at twice their rated capacity prior to initial use. The employer shall retain a certificate of proof test, and make it available for examination.

- (16) Wire rope slings shall have permanently affixed, legible identification markings stating size, rated capacity for the type(s) of hitch(es) used and the angle upon which it is based, and the number of legs if more than one.

(d) Natural rope, and synthetic fiber.

- (1) Employers must not use natural- and synthetic-fiber rope slings with loads in excess of the rated capacities (i.e., working load limits) indicated on the sling by permanently affixed and legible identification markings prescribed by the manufacturer.

- (2) All splices in rope slings provided by the employer shall be made in accordance with fiber rope manufacturers recommendations.

- (i) In manila rope, eye splices shall contain at least three full tucks, and short splices shall contain at least six full tucks (three on each side of the center line of the splice).
  - (ii) In layed synthetic fiber rope, eye splices shall contain at least four full tucks, and short splices shall contain at least eight full tucks (four on each side of the center line of the splice).
  - (iii) Strand end tails shall not be trimmed short (flush with the surface of the rope) immediately adjacent to the full tucks. This precaution applies to both eye and short splices and all types of fiber rope. For fiber ropes under 1-inch diameter, the tails shall project at least six rope diameters beyond the last full tuck. For fiber ropes 1-inch diameter and larger, the tails shall project at least 6 inches beyond the last full tuck. In applications where the projecting tails may be objectionable, the tails shall be tapered and spliced into the body of the rope using at least two additional tucks (which will require a tail length of approximately six rope diameters beyond the last full tuck).
  - (iv) For all eye splices, the eye shall be sufficiently large to provide an included angle of not greater than 60 deg. at the splice when the eye is placed over the load or support.
  - (v) Knots shall not be used in lieu of splices.
- (3) "Safe operating temperatures." Natural and synthetic fiber rope slings, except for wet frozen slings, may be used in a temperature range from minus 20 deg. F (-28.88 deg. C) to plus 180 deg. F (82.2 deg. C) without decreasing the working load limit. For operations outside this temperature range and for wet frozen slings, the sling manufacturer's recommendations shall be followed.
- (4) "Splicing." Spliced fiber rope slings shall not be used unless they have been spliced in accordance with the following minimum requirements and in accordance with any additional recommendations of the manufacturer:
- (i) In manila rope, eye splices shall consist of at least three full tucks, and short splices shall consist of at least six full tucks, three on each side of the splice center line.
  - (ii) In synthetic fiber rope, eye splices shall consist of at least four full tucks, and short splices shall consist of at least eight full tucks, four on each side of the center line.
  - (iii) Strand end tails shall not be trimmed flush with the surface of the rope immediately adjacent to the full tucks. This applies to all types of fiber rope and both eye and short splices. For fiber rope under 1 inch (2.54 cm) in diameter, the tail shall project at least six rope diameters beyond the last full tuck. For fiber rope 1 inch (2.54 cm) in diameter and larger, the tail shall project at least 6 inches (15.24 cm) beyond the last full tuck. Where a projecting tail interferes with the use of the sling, the tail shall be tapered and spliced into the body of the rope using at least two additional tucks (which will require a tail length of approximately six rope diameters beyond the last full tuck).
- (iv) Fiber rope slings shall have a minimum clear length of rope between eye splices equal to 10 times the rope diameter.
  - (v) Knots shall not be used in lieu of splices.
  - (vi) Clamps not designed specifically for fiber ropes shall not be used for splicing.
  - (vii) For all eye splices, the eye shall be of such size to provide an included angle of not greater than 60 degrees at the splice when the eye is placed over the load or support.
- (5) "End attachments." Fiber rope slings shall not be used if end attachments in contact with the rope have sharp edges or projections.
- (6) "Removal from service." Natural and synthetic fiber rope slings shall be immediately removed from service if any of the following conditions are present:
- (i) Abnormal wear.
  - (ii) Powdered fiber between strands.
  - (iii) Broken or cut fibers.
  - (iv) Variations in the size or roundness of strands.
  - (v) Discoloration or rotting.
  - (vi) Distortion of hardware in the sling.
- (7) Employers must use natural- and synthetic-fiber rope slings that have permanently affixed and legible identification markings that state the rated capacity for the type(s) of hitch(es) used and the angle upon which it is based, type of fiber material, and the number of legs if more than one.
- (e) Synthetic webbing (nylon, polyester, and polypropylene).
- (1) The employer shall have each synthetic web sling marked or coded to show:
    - (i) Name or trademark of manufacturer.
    - (ii) Rated capacities for the type of hitch.
    - (iii) Type of material.
  - (2) Rated capacity shall not be exceeded.
  - (3) "Webbing." Synthetic webbing shall be of uniform thickness and width and selvage edges shall not be split from the webbing's width.
  - (4) "Fittings." Fittings shall be:

- (i) Of a minimum breaking strength equal to that of the sling; and
  - (ii) Free of all sharp edges that could in any way damage the webbing.
- (5) "Attachment of end fittings to webbing and formation of eyes." Stitching shall be the only method used to attach end fittings to webbing and to form eyes. The thread shall be in an even pattern and contain a sufficient number of stitches to develop the full breaking strength of the sling.
- (6) "Environmental conditions." When synthetic web slings are used, the following precautions shall be taken:
- (i) Nylon web slings shall not be used where fumes, vapors, sprays, mists or liquids of acids or phenolics are present.
  - (ii) Polyester and polypropylene web slings shall not be used where fumes, vapors, sprays, mists or liquids of caustics are present.
  - (iii) Web slings with aluminum fittings shall not be used where fumes, vapors, sprays, mists or liquids of caustics are present.
- (7) "Safe operating temperatures." Synthetic web slings of polyester and nylon shall not be used at temperatures in excess of 180 deg. F (82.2 deg. C). Polypropylene web slings shall not be used at temperatures in excess of 200 deg. F (93.33 deg. C).
- (8) "Removal from service." Synthetic web slings shall be immediately removed from service if any of the following conditions are present:
- (i) Acid or caustic burns;
  - (ii) Melting or charring of any part of the sling surface;
  - (iii) Snags, punctures, tears or cuts;
  - (iv) Broken or worn stitches; or
  - (v) Distortion of fittings.
- (f) Shackles and hooks.
- (1) Employers must not use shackles with loads in excess of the rated capacities (i.e., working load limits) indicated on the shackle by permanently affixed and legible identification markings prescribed by the manufacturer.
  - (2) The manufacturer's recommendations shall be followed in determining the safe working loads of the various sizes and types of specific and identifiable hooks. All hooks for which no applicable manufacturer's recommendations are available shall be tested to twice the intended safe working load before they are initially put into use. The employer shall maintain a record of the dates and results of such tests.

**TABLE H-1  
MAXIMUM ALLOWABLE WEAR AT ANY POINT  
OF LINE**

Chain size (inches)	Minimum allowable wear (inch)
1/4" .....	3/64"
3/8" .....	5/64"
1/2" .....	7/64"
5/8" .....	9/64"
3/4" .....	5/32"
7/8" .....	11/64"
1" .....	3/16"
1 1/8" .....	7/32"
1 1/4" .....	1/4"
1 3/8" .....	9/32"
1 1/2" .....	5/16"
1 3/4" .....	11/32"

**TABLE H-2  
NUMBER AND SPACING OF U-BOLT  
WIRE ROPE CLIPS**

Improved plow steel rope diameter (inches)	Number of clips		Minimum spacing (inches)
	Drop forged	Other material	
1/2" .....	3	4	3
5/8" .....	3	4	3¾
3/4" .....	4	5	4½
7/8" .....	4	5	5¼
1" .....	5	6	6
1 1/8" .....	6	6	6¾
1 1/4" .....	6	7	7½
1 3/8" .....	7	7	8¼
1 1/2" .....	7	8	9



**CHAPTER 6:**  
**OSHA 29 CFR 1926, Subpart CC – Cranes and Derricks in Construction**

**OSHA 1926 Subpart CC – Cranes and Derricks in Construction**

Reprinted from Occupational Safety and Health Administration (OSHA) standard. All rights reserved.

This page intentionally left blank



# OSHA 1926 Subpart CC – Cranes and Derricks in Construction

## Regulations 1926 Subpart CC

- Part Number: 1926
- Part Title: Occupational Safety and Health Standards
- Subpart: CC
- Subpart Title: Cranes and Derricks in Construction
- Applicable Standards: 1926.1401; 1926.1404–1411; 1926.1419–1422; 1926.1424–1925; 1926.1431–1432; Appendix A

## § 1926.1401 Definitions

*A/D director (Assembly/Disassembly director)* means an individual who meets this subpart’s requirements for an A/D director, irrespective of the person’s formal job title or whether the person is non-management or management personnel.

*Articulating crane* means a crane whose boom consists of a series of folding, pin connected structural members, typically manipulated to extend or retract by power from hydraulic cylinders.

*Assembly/Disassembly* means the assembly and/or disassembly of equipment covered under this standard. With regard to tower cranes, “erecting and climbing” replaces the term “assembly,” and “dismantling” replaces the term “disassembly.” Regardless of whether the crane is initially erected to its full height or is climbed in stages, the process of increasing the height of the crane is an erection process.

*Assist crane* means a crane used to assist in assembling or disassembling a crane.

*Attachments* means any device that expands the range of tasks that can be done by the equipment. Examples include, but are not limited to: An auger, drill, magnet, pile-driver, and boom-attached personnel platform.

*Audible signal* means a signal made by a distinct sound or series of sounds. Examples include, but are not limited to, sounds made by a bell, horn, or whistle.

*Blocking* (also referred to as “cribbing”) is wood or other material used to support equipment or a component and distribute loads to the ground. It is typically used to support lattice boom sections during assembly/ disassembly and under outrigger and stabilizer floats.

*Boatswain’s chair* means a single-point adjustable suspension scaffold consisting of a seat or sling (which may be incorporated into a full body harness) designed to support one employee in a sitting position.

*Bogie* means “travel bogie,” which is defined below.

*Boom (equipment other than tower crane)* means an inclined spar, strut, or other long structural member which supports the upper hoisting tackle on a crane or derrick. Typically, the length and vertical angle of the boom can be varied to achieve increased height or height and reach when lifting loads. Booms can usually be grouped into general categories of hydraulically extendible, cantilevered type, latticed section, cable supported type or articulating type.

*Boom (tower cranes):* On tower cranes, if the “boom” (i.e., principal horizontal structure) is fixed, it is referred to as a jib; if it is moveable up and down, it is referred to as a boom.

*Boom angle indicator* means a device which measures the angle of the boom relative to horizontal.

*Boom hoist limiting device* includes boom hoist disengaging device, boom hoist shut-off, boom hoist disconnect, boom hoist hydraulic relief, boom hoist kick-outs, automatic boom stop device, or derricking limiter. This type of device disengages boom hoist power when the boom reaches a predetermined operating angle. It also sets brakes or closes valves to prevent the boom from lowering after power is disengaged.

*Boom length indicator* indicates the length of the permanent part of the boom (such as ruled markings on the boom) or, as in some computerized systems, the length of the boom with extensions/ attachments.

*Boom stop* includes boom stops, (belly straps with struts/standoff), telescoping boom stops, attachment boom stops, and backstops. These devices restrict the boom from moving above a certain maximum angle and toppling over backward.

*Boom suspension system* means a system of pendants, running ropes, sheaves, and other hardware which supports the boom tip and controls the boom angle.

*Builder* means the builder/constructor of equipment.

*Center of gravity:* The center of gravity of any object is the point in the object around which its weight is evenly distributed. If you could put a support under

that point, you could balance the object on the support.

*Certified welder* means a welder who meets nationally recognized certification requirements applicable to the task being performed.

*Climbing* means the process in which a tower crane is raised to a new working height, either by adding additional tower sections to the top of the crane (top climbing), or by a system in which the entire crane is raised inside the structure (inside climbing).

*Come-a-long* means a mechanical device typically consisting of a chain or cable attached at each end that is used to facilitate movement of materials through leverage.

*Competent person* means one who is capable of identifying existing and predictable hazards in the surroundings or working conditions which are unsanitary, hazardous, or dangerous to employees, and who has authorization to take prompt corrective measures to eliminate them.

*Controlled load lowering* means lowering a load by means of a mechanical hoist drum device that allows a hoisted load to be lowered with maximum control using the gear train or hydraulic components of the hoist mechanism. Controlled load lowering requires the use of the hoist drive motor, rather than the load hoist brake, to lower the load.

*Controlling entity* means an employer that is a prime contractor, general contractor, construction manager or any other legal entity which has the overall responsibility for the construction of the project—its planning, quality and completion.

*Counterweight* means a weight used to supplement the weight of equipment in providing stability for lifting loads by counterbalancing those loads.

*Crane/derrick* includes all equipment covered by this subpart.

*Crawler crane* means equipment that has a type of base mounting which incorporates a continuous belt of sprocket driven track.

*Crossover points* means locations on a wire rope which is spooled on a drum where one layer of rope climbs up on and crosses over the previous layer. This takes place at each flange of the drum as the rope is spooled onto the drum, reaches the flange, and begins to wrap back in the opposite direction.

*Dedicated channel* means a line of communication assigned by the employer who controls the communication system to only one signal person and crane/derrick or to a coordinated group of cranes/derricks/ signal person(s).

*Dedicated pile-driver* is a machine that is designed to function exclusively as a pile-driver. These machines typically have the ability to both hoist the mate-

rial that will be pile-driven and to pile-drive that material.

*Dedicated spotter (power lines)*: To be considered a dedicated spotter, the requirements of § 1926.1428 (Signal person qualifications) must be met and his/her sole responsibility is to watch the separation between the power line and the equipment, load line and load (including rigging and lifting accessories), and ensure through communication with the operator that the applicable minimum approach distance is not breached.

*Directly under the load* means a part or all of an employee is directly beneath the load.

*Dismantling* includes partial dismantling (such as dismantling to shorten a boom or substitute a different component).

*Drum rotation indicator* means a device on a crane or hoist which indicates in which direction and at what relative speed a particular hoist drum is turning.

*Electrical contact* occurs when a person, object, or equipment makes contact or comes in close proximity with an energized conductor or equipment that allows the passage of current.

*Employer-made equipment* means floating cranes/derricks designed and built by an employer for the employer's own use.

*Encroachment* is where any part of the crane, load line or load (including rigging and lifting accessories) breaches a minimum clearance distance that this subpart requires to be maintained from a power line.

*Equipment* means equipment covered by this subpart.

*Equipment criteria* means instructions, recommendations, limitations and specifications.

*Fall protection equipment* means guardrail systems, safety net systems, personal fall arrest systems, positioning device systems or fall restraint systems.

*Fall restraint system* means a fall protection system that prevents the user from falling any distance. The system is comprised of either a body belt or body harness, along with an anchorage, connectors and other necessary equipment. The other components typically include a lanyard, and may also include a lifeline and other devices.

*Fall zone* means the area (including but not limited to the area directly beneath the load) in which it is reasonably foreseeable that partially or completely suspended materials could fall in the event of an accident.

*Flange points* are points of contact between rope and drum flange where the rope changes layers.

*Floating cranes/derricks* means equipment designed by the manufacturer (or employer) for marine use by



permanent attachment to a barge, pontoons, vessel or other means of flotation.

*For example* means “one example, although there are others.”

*Free fall (of the load line)* means that only the brake is used to regulate the descent of the load line (the drive mechanism is not used to drive the load down faster or retard its lowering).

*Free surface effect* is the uncontrolled transverse movement of liquids in compartments which reduce a vessel’s transverse stability.

*Hoist* means a mechanical device for lifting and lowering loads by winding a line onto or off a drum.

*Hoisting* is the act of raising, lowering or otherwise moving a load in the air with equipment covered by this standard. As used in this standard, “hoisting” can be done by means other than wire rope/hoist drum equipment.

*Include/including* means “including, but not limited to.”

*Insulating link/device* means an insulating device listed, labeled, or accepted by a Nationally Recognized Testing Laboratory in accordance with 29 CFR 1910.7.

*Jib stop* (also referred to as a jib backstop), is the same type of device as a boom stop but is for a fixed or luffing jib.

*Land crane/derrick* is equipment not originally designed by the manufacturer for marine use by permanent attachment to barges, pontoons, vessels, or other means of flotation.

*List* means the angle of inclination about the longitudinal axis of a barge, pontoons, vessel or other means of flotation.

*Load* refers to the object(s) being hoisted and/or the weight of the object(s); both uses refer to the object(s) and the load-attaching equipment, such as, the load block, ropes, slings, shackles, and any other ancillary attachment.

*Load moment (or rated capacity) indicator* means a system which aids the equipment operator by sensing (directly or indirectly) the overturning moment on the equipment, i.e., load multiplied by radius. It compares this lifting condition to the equipment’s rated capacity, and indicates to the operator the percentage of capacity at which the equipment is working. Lights, bells, or buzzers may be incorporated as a warning of an approaching overload condition.

*Load moment (or rated capacity) limiter* means a system which aids the equipment operator by sensing (directly or indirectly) the overturning moment on the equipment, i.e., load multiplied by radius. It compares this lifting condition to the equipment’s rated capacity, and when the rated capacity is reached, it shuts off power to those equipment

functions which can increase the severity of loading on the equipment, e.g., hoisting, telescoping out, or luffing out. Typically, those functions which decrease the severity of loading on the equipment remain operational, e.g., lowering, telescoping in, or luffing in.

*Locomotive crane* means a crane mounted on a base or car equipped for travel on a railroad track.

*Luffing jib limiting device* is similar to a boom hoist limiting device, except that it limits the movement of the luffing jib.

*Marine hoisted personnel transfer device* means a device, such as a “transfer net,” that is designed to protect the employees being hoisted during a marine transfer and to facilitate rapid entry into and exit from the device. Such devices do not include boatswain’s chairs when hoisted by equipment covered by this standard.

*Marine worksite* means a construction worksite located in, on or above the water.

*Mobile crane* means a lifting device incorporating a cable suspended latticed boom or hydraulic telescopic boom designed to be moved between operating locations by transport over the road.

*Moving point-to-point* means the times during which an employee is in the process of going to or from a work station.

*Multi-purpose machine* means a machine that is designed to be configured in various ways, at least one of which allows it to hoist (by means of a winch or hook) and horizontally move a suspended load. For example, a machine that can rotate and can be configured with removable forks/tongs (for use as a forklift) or with a winch pack, jib (with a hook at the end) or jib used in conjunction with a winch. When configured with the forks/tongs, it is not covered by this subpart. When configured with a winch pack, jib (with a hook at the end) or jib used in conjunction with a winch, it is covered by this subpart.

*Nationally recognized accrediting agency* is an organization that, due to its independence and expertise, is widely recognized as competent to accredit testing organizations. Examples of such accrediting agencies include, but are not limited to, the National Commission for Certifying Agencies and the American National Standards Institute.

*Nonconductive* means that, because of the nature and condition of the materials used, and the conditions of use (including environmental conditions and condition of the material), the object in question has the property of not becoming energized (that is, it has high dielectric properties offering a high resistance to the passage of current under the conditions of use).

*Operational aids* are devices that assist the operator in the safe operation of the crane by providing information or automatically taking control of a crane function. These include, but are not limited to, the devices listed in § 1926.1416 (“listed operational aids”).

*Operational controls* means levers, switches, pedals and other devices for controlling equipment operation.

*Operator* means a person who is operating the equipment.

*Overhead and gantry cranes* includes overhead/bridge cranes, semigantry, cantilever gantry, wall cranes, storage bridge cranes, launching gantry cranes, and similar equipment, irrespective of whether it travels on tracks, wheels, or other means.

*Paragraph* refers to a paragraph in the same section of this subpart that the word “paragraph” is used, unless otherwise specified.

*Pendants* includes both wire and bar types. Wire type: A fixed length of wire rope with mechanical fittings at both ends for pinning segments of wire rope together. Bar type: Instead of wire rope, a bar is used. Pendants are typically used in a latticed boom crane system to easily change the length of the boom suspension system without completely changing the rope on the drum when the boom length is increased or decreased.

*Personal fall arrest system* means a system used to arrest an employee in a fall from a working level. It consists of an anchorage, connectors, a body harness and may include a lanyard, deceleration device, lifeline, or suitable combination of these.

*Portal crane* is a type of crane consisting of a rotating upperstructure, hoist machinery, and boom mounted on top of a structural gantry which may be fixed in one location or have travel capability. The gantry legs or columns usually have portal openings in between to allow passage of traffic beneath the gantry.

*Power lines* means electric transmission and distribution lines.

*Procedures* include, but are not limited to: Instructions, diagrams, recommendations, warnings, specifications, protocols and limitations.

*Proximity alarm* is a device that provides a warning of proximity to a power line and that has been listed, labeled, or accepted by a Nationally Recognized Testing Laboratory in accordance with 29 CFR 1910.7.

*Qualified evaluator (not a third party)* means a person employed by the signal person’s employer who has demonstrated that he/she is competent in accurately assessing whether individuals meet the Qualification Requirements in this subpart for a signal person.

*Qualified evaluator (third party)* means an entity that, due to its independence and expertise, has demonstrated that it is competent in accurately assessing whether individuals meet the Qualification Requirements in this subpart for a signal person.

*Qualified person* means a person who, by possession of a recognized degree, certificate, or professional standing, or who by extensive knowledge, training and experience, successfully demonstrated the ability to solve/ resolve problems relating to the subject matter, the work, or the project.

*Qualified rigger* is a rigger who meets the criteria for a qualified person.

*Range control limit device* is a device that can be set by an equipment operator to limit movement of the boom or jib tip to a plane or multiple planes.

*Range control warning device* is a device that can be set by an equipment operator to warn that the boom or jib tip is at a plane or multiple planes.

*Rated capacity* means the maximum working load permitted by the manufacturer under specified working conditions. Such working conditions typically include a specific combination of factors such as equipment configuration, radii, boom length, and other parameters of use.

*Rated capacity indicator: See* load moment indicator.

*Rated capacity limiter: See* load moment limiter.

*Repetitive pickup points* refer to, when operating on a short cycle operation, the rope being used on a single layer and being spooled repetitively over a short portion of the drum.

*Running wire rope* means a wire rope that moves over sheaves or drums.

*Runway* means a firm, level surface designed, prepared and designated as a path of travel for the weight and configuration of the crane being used to lift and travel with the crane suspended platform. An existing surface may be used as long as it meets these criteria.

*Section* means a section of this subpart, unless otherwise specified.

*Sideboom crane* means a track-type or wheel-type tractor having a boom mounted on the side of the tractor, used for lifting, lowering or transporting a load suspended on the load hook. The boom or hook can be lifted or lowered in a vertical direction only.

*Special hazard warnings* means warnings of site-specific hazards (for example, proximity of power lines).

*Stability (flotation device)* means the tendency of a barge, pontoons, vessel or other means of flotation to return to an upright position after having been inclined by an external force.

*Standard Method* means the protocol in Appendix A of this subpart for hand signals.

*Such as* means “such as, but not limited to.”

*Superstructure*: See Upperworks.

*Tagline* means a rope (usually fiber) attached to a lifted load for purposes of controlling load spinning and pendular motions or used to stabilize a bucket or magnet during material handling operations.

*Tender* means an individual responsible for monitoring and communicating with a diver.

*Tilt up or tilt down operation* means raising/lowering a load from the horizontal to vertical or vertical to horizontal.

*Tower crane* is a type of lifting structure which utilizes a vertical mast or tower to support a working boom (jib) in an elevated position. Loads are suspended from the working boom. While the working boom may be of the fixed type (horizontal or angled) or have luffing capability, it can always rotate to swing loads, either by rotating on the top of the tower (top slewing) or by the rotation of the tower (bottom slewing). The tower base may be fixed in one location or ballasted and moveable between locations. Mobile cranes that are configured with luffing jib and/or tower attachments are not considered tower cranes under this section.

*Travel bogie (tower cranes)* is an assembly of two or more axles arranged to permit vertical wheel displacement and equalize the loading on the wheels.

*Trim* means angle of inclination about the transverse axis of a barge, pontoons, vessel or other means of floatation.

*Two blocking* means a condition in which a component that is uppermost on the hoist line such as the load block, hook block, overhaul ball, or similar component, comes in contact with the boom tip, fixed upper block or similar component. This binds the system and continued application of power can cause failure of the hoist rope or other component.

*Unavailable procedures* means procedures that are no longer available from the manufacturer, or have never been available, from the manufacturer.

*Upperstructure*: See Upperworks.

*Upperworks* means the revolving frame of equipment on which the operating machinery (and many cases the engine) are mounted along with the operator's cab. The counterweight is typically supported on the rear of the upperstructure and the boom or other front end attachment is mounted on the front.

*Up to* means “up to and including.”

*Wire rope* means a flexible rope constructed by laying steel wires into various patterns of multi-wired strands around a core system to produce a helically wound rope.

## § 1926.1402 Ground conditions

(a) Definitions.

- (1) “Ground conditions” means the ability of the ground to support the equipment (including slope, compaction, and firmness).
- (2) “Supporting materials” means blocking, mats, cribbing, marsh buggies (in marshes/wetlands), or similar supporting materials or devices.

(b) The equipment must not be assembled or used unless ground conditions are firm, drained, and graded to a sufficient extent so that, in conjunction (if necessary) with the use of supporting materials, the equipment manufacturer's specifications for adequate support and degree of level of the equipment are met. The requirement for the ground to be drained does not apply to marshes/wetlands.

(c) The controlling entity must:

- (1) Ensure that ground preparations necessary to meet the requirements in paragraph (b) of this section are provided.
- (2) Inform the user of the equipment and the operator of the location of hazards beneath the equipment set-up area (such as voids, tanks, utilities) if those hazards are identified in documents (such as site drawings, as-built drawings, and soil analyses) that are in the possession of the controlling entity (whether at the site or off-site) or the hazards are otherwise known to that controlling entity.

(d) If there is no controlling entity for the project, the requirement in paragraph (c)(1) of this section must be met by the employer that has authority at the site to make or arrange for ground preparations needed to meet paragraph (b) of this section.

(e) If the A/D director or the operator determines that ground conditions do not meet the requirements in paragraph (b) of this section, that person's employer must have a discussion with the controlling entity regarding the ground preparations that are needed so that, with the use of suitable supporting materials/devices (if necessary), the requirements in paragraph (b) of this section can be met.

(f) This section does not apply to cranes designed for use on railroad tracks when used on railroad tracks that are part of the general railroad system of transportation that is regulated pursuant to the Federal Railroad Administration under 49 CFR part 213 and that comply with applicable Federal Railroad Administration requirements.

### § 1926.1403 Assembly/Disassembly—selection of manufacturer or employer procedures

When assembling or disassembling equipment (or attachments), the employer must comply with all applicable manufacturer prohibitions and must comply with either:

- (a) Manufacturer procedures applicable to assembly and disassembly, or
- (b) Employer procedures for assembly and disassembly. Employer procedures may be used only where the employer can demonstrate that the procedures used meet the requirements in § 1926.1406. Note: The employer must follow manufacturer procedures when an employer uses synthetic slings during assembly or disassembly rigging. (See § 1926.1404(r).)

### § 1926.1404 Assembly/Disassembly—general requirements (applies to all assembly and disassembly operations)

#### (a) *Supervision—competent-qualified person.*

- (1) Assembly/disassembly must be directed by a person who meets the criteria for both a competent person and a qualified person, or by a competent person who is assisted by one or more qualified persons (“A/D director”).
- (2) Where the assembly/disassembly is being performed by only one person, that person must meet the criteria for both a competent person and a qualified person. For purposes of this standard, that person is considered the A/D director.

(b) *Knowledge of procedures.* The A/D director must understand the applicable assembly/disassembly procedures.

(c) *Review of procedures.* The A/D director must review the applicable assembly/disassembly procedures immediately prior to the commencement of assembly/disassembly unless the A/D director understands the procedures and has applied them to the same type and configuration of equipment (including accessories, if any).

#### (d) *Crew instructions.*

- (1) Before commencing assembly/disassembly operations, the A/D director must ensure that the crew members understand all of the following:
  - (i) Their tasks.
  - (ii) The hazards associated with their tasks.
  - (iii) The hazardous positions/locations that they need to avoid.

(2) During assembly/disassembly operations, before a crew member takes on a different task, or when adding new personnel during the operations, the requirements in paragraphs (d)(1)(i) through (d)(1)(iii) of this section must be met.

#### (e) *Protecting assembly/disassembly crew members out of operator view.*

- (1) Before a crew member goes to a location that is out of view of the operator and is either in, on, or under the equipment, or near the equipment (or load) where the crew member could be injured by movement of the equipment (or load), the crew member must inform the operator that he/she is going to that location.
- (2) Where the operator knows that a crew member went to a location covered by paragraph (e) (1) of this section, the operator must not move any part of the equipment (or load) until the operator is informed in accordance with a pre-arranged system of communication that the crew member is in a safe position.

#### (f) *Working under the boom, jib or other components.*

- (1) When pins (or similar devices) are being removed, employees must not be under the boom, jib, or other components, except where the requirements of paragraph (f)(2) of this section are met.
- (2) *Exception.* Where the employer demonstrates that site constraints require one or more employees to be under the boom, jib, or other components when pins (or similar devices) are being removed, the A/D director must implement procedures that minimize the risk of unintended dangerous movement and minimize the duration and extent of exposure under the boom. (See Non-mandatory Appendix B of this subpart for an example.)

(g) *Capacity limits.* During all phases of assembly/disassembly, rated capacity limits for loads imposed on the equipment, equipment components (including rigging), lifting lugs and equipment accessories, must not be exceeded for the equipment being assembled/disassembled.

(h) *Addressing specific hazards.* The A/D director supervising the assembly/disassembly operation must address the hazards associated with the operation, which include:

- (1) Site and ground bearing conditions. Site and ground conditions must be adequate for safe assembly/disassembly operations and to support the equipment during assembly/disassembly (see § 1926.1402 for ground condition requirements).
- (2) Blocking material. The size, amount, condition and method of stacking the blocking must be

- sufficient to sustain the loads and maintain stability.
- (3) Proper location of blocking. When used to support lattice booms or components, blocking must be appropriately placed to:
    - (i) Protect the structural integrity of the equipment, and
    - (ii) Prevent dangerous movement and collapse.
  - (4) Verifying assist crane loads. When using an assist crane, the loads that will be imposed on the assist crane at each phase of assembly/disassembly must be verified in accordance with § 1926.1417(o)(3) before assembly/ disassembly begins.
  - (5) Boom and jib pick points. The point(s) of attachment of rigging to a boom (or boom sections or jib or jib sections) must be suitable for preventing structural damage and facilitating safe handling of these components.
  - (6) *Center of gravity.*
    - (i) The center of gravity of the load must be identified if that is necessary for the method used for maintaining stability.
    - (ii) Where there is insufficient information to accurately identify the center of gravity, measures designed to prevent unintended dangerous movement resulting from an inaccurate identification of the center of gravity must be used. (*See Non-mandatory Appendix B of this subpart for an example.*)
  - (7) *Stability upon pin removal.* The boom sections, boom suspension systems (such as gantry A-frames and jib struts), and components must be rigged or supported to maintain stability upon the removal of the pins.
  - (8) *Snagging.* Suspension ropes and pendants must not be allowed to catch on the boom or jib connection pins or cotter pins (including keepers and locking pins).
  - (9) *Struck by counterweights.* The potential for unintended movement from inadequately supported counterweights and from hoisting counterweights.
  - (10) *Boom hoist brake failure.* Each time reliance is to be placed on the boom hoist brake to prevent boom movement during assembly/ disassembly, the brake must be tested prior to such reliance to determine if it is sufficient to prevent boom movement. If it is not sufficient, a boom hoist pawl, other locking device/back-up braking device, or another method of preventing dangerous movement of the boom (such as blocking or using an assist crane) from a boom hoist brake failure must be used.
  - (11) *Loss of backward stability.* Backward stability before swinging the upperworks, travel, and when attaching or removing equipment components.
  - (12) *Wind speed and weather.* The effect of wind speed and weather on the equipment.
  - (i) [*Reserved.*]
  - (j) *Cantilevered boom sections.* Manufacturer limitations on the maximum amount of boom supported only by cantilevering must not be exceeded. Where these are unavailable, a registered professional engineer familiar with the type of equipment involved must determine in writing this limitation, which must not be exceeded.
  - (k) *Weight of components.* The weight of each of the components must be readily available.
  - (l) [*Reserved.*]
  - (m) *Components and configuration.*
    - (1) The selection of components, and configuration of the equipment, that affect the capacity or safe operation of the equipment must be in accordance with:
      - (i) Manufacturer instructions, prohibitions, limitations, and specifications. Where these are unavailable, a registered professional engineer familiar with the type of equipment involved must approve, in writing, the selection and configuration of components; or
      - (ii) Approved modifications that meet the requirements of § 1926.1434 (Equipment modifications).
    - (2) *Post-assembly inspection.* Upon completion of assembly, the equipment must be inspected to ensure compliance with paragraph (m)(1) of this section (*see* § 1926.1412(c) for post-assembly inspection requirements).
  - (n) [*Reserved.*]
  - (o) *Shipping pins.* Reusable shipping pins, straps, links, and similar equipment must be removed. Once they are removed they must either be stowed or otherwise stored so that they do not present a falling object hazard.
  - (p) *Pile driving.* Equipment used for pile driving must not have a jib attached during pile driving operations.
  - (q) *Outriggers and Stabilizers.* When the load to be handled and the operating radius require the use of outriggers or stabilizers, or at any time when outriggers or stabilizers are used, all of the following requirements must be met (except as otherwise indicated):
    - (1) The outriggers or stabilizers must be either fully extended or, if manufacturer procedures permit, deployed as specified in the load chart.

- (2) The outriggers must be set to remove the equipment weight from the wheels, except for locomotive cranes (*see* paragraph (q)(6) of this section for use of outriggers on locomotive cranes). This provision does not apply to stabilizers.
- (3) When outrigger floats are used, they must be attached to the outriggers. When stabilizer floats are used, they must be attached to the stabilizers.
- (4) Each outrigger or stabilizer must be visible to the operator or to a signal person during extension and setting.
- (5) Outrigger and stabilizer blocking must:
  - (i) Meet the requirements in paragraphs (h)(2) and (h)(3) of this section.
  - (ii) Be placed only under the outrigger or stabilizer float/pad of the jack or, where the outrigger or stabilizer is designed without a jack, under the outer bearing surface of the extended outrigger or stabilizer beam.
- (6) For locomotive cranes, when using outriggers or stabilizers to handle loads, the manufacturer's procedures must be followed. When lifting loads without using outriggers or stabilizers, the manufacturer's procedures must be met regarding truck wedges or screws.
- (r) *Rigging*. In addition to following the requirements in 29 CFR 1926.251 and other requirements in this and other standards applicable to rigging, when rigging is used for assembly/ disassembly, the employer must ensure that:
  - (1) The rigging work is done by a qualified rigger.
  - (2) Synthetic slings are protected from: Abrasive, sharp or acute edges, and configurations that could cause a reduction of the sling's rated capacity, such as distortion or localized compression. **Note:** Requirements for the protection of wire rope slings are contained in 29 CFR 1926.251(c)(9).
  - (3) When synthetic slings are used, the synthetic sling manufacturer's instructions, limitations, specifications and recommendations must be followed.

**§ 1926.1405 Disassembly—additional requirements for dismantling of booms and jibs (applies to both the use of manufacturer procedures and employer procedures)**

*Dismantling (including dismantling for changing the length of) booms and jibs.*

- (a) None of the pins in the pendants are to be removed (partly or completely) when the pendants are in tension.

- (b) None of the pins (top or bottom) on boom sections located between the pendant attachment points and the crane/derrick body are to be removed (partly or completely) when the pendants are in tension.
- (c) None of the pins (top or bottom) on boom sections located between the uppermost boom section and the crane/ derrick body are to be removed (partly or completely) when the boom is being supported by the uppermost boom section resting on the ground (or other support).
- (d) None of the top pins on boom sections located on the cantilevered portion of the boom being removed (the portion being removed ahead of the pendant attachment points) are to be removed (partly or completely) until the cantilevered section to be removed is fully supported.

**§ 1926.1406 Assembly/Disassembly—employer procedures—general requirements**

- (a) When using employer procedures instead of manufacturer procedures for assembly/disassembly, the employer must ensure that the procedures:
  - (1) Prevent unintended dangerous movement, and prevent collapse, of any part of the equipment.
  - (2) Provide adequate support and stability of all parts of the equipment.
  - (3) Position employees involved in the assembly/ disassembly operation so that their exposure to unintended movement or collapse of part or all of the equipment is minimized.
- (b) *Qualified person*. Employer procedures must be developed by a qualified person.

**§ 1926.1407 Power line safety (up to 350 kV)—assembly and disassembly.**

- (a) Before assembling or disassembling equipment, the employer must determine if any part of the equipment, load line, or load (including rigging and lifting accessories) could get, in the direction or area of assembly/ disassembly, closer than 20 feet to a power line during the assembly/ disassembly process. If so, the employer must meet the requirements in Option (1), Option (2), or Option (3) of this section, as follows:
  - (1) *Option (1)—Deenergize and ground*. Confirm from the utility owner/ operator that the power line has been deenergized and visibly grounded at the worksite.
  - (2) *Option (2)—20 foot clearance*. Ensure that no part of the equipment, load line or load (including rigging and lifting accessories), gets closer than 20 feet to the power line by implementing the measures specified in paragraph (b) of this section.
  - (3) *Option (3)—Table A clearance*.

- (i) Determine the line's voltage and the minimum clearance distance permitted under Table A (see § 1926.1408).
  - (ii) Determine if any part of the equipment, load line, or load (including rigging and lifting accessories), could get closer than the minimum clearance distance to the power line permitted under Table A (see § 1926.1408). If so, then the employer must follow the requirements in paragraph (b) of this section to ensure that no part of the equipment, load line, or load (including rigging and lifting accessories), gets closer to the line than the minimum clearance distance.
- (b) *Preventing encroachment/ electrocution.* Where encroachment precautions are required under Option (2), or Option (3) of this section, all of the following requirements must be met:
- (1) Conduct a planning meeting with the Assembly/ Disassembly director (A/D director), operator, assembly/ disassembly crew and the other workers who will be in the assembly/ disassembly area to review the location of the power line(s) and the steps that will be implemented to prevent encroachment/electrocution.
  - (2) If tag lines are used, they must be nonconductive.
  - (3) At least one of the following additional measures must be in place. The measure selected from this list must be effective in preventing encroachment.
- The additional measures are:
- (i) Use a dedicated spotter who is in continuous contact with the equipment operator. The dedicated spotter must:
    - (A) Be equipped with a visual aid to assist in identifying the minimum clearance distance. Examples of a visual aid include, but are not limited to: A clearly visible line painted on the ground; a clearly visible line of stanchions; a set of clearly visible line-of-sight landmarks (such as a fence post behind the dedicated spotter and a building corner ahead of the dedicated spotter).
    - (B) Be positioned to effectively gauge the clearance distance.
    - (C) Where necessary, use equipment that enables the dedicated spotter to communicate directly with the operator.
    - (D) Give timely information to the operator so that the required clearance distance can be maintained.
  - (ii) A proximity alarm set to give the operator sufficient warning to prevent encroachment.
    - (iii) A device that automatically warns the operator when to stop movement, such as a range control warning device. Such a device must be set to give the operator sufficient warning to prevent encroachment.
    - (iv) A device that automatically limits range of movement, set to prevent encroachment.
    - (v) An elevated warning line, barricade, or line of signs, in view of the operator, equipped with flags or similar high-visibility markings.
- (c) *Assembly/disassembly below power lines prohibited.* No part of a crane/derrick, load line, or load (including rigging and lifting accessories), whether partially or fully assembled, is allowed below a power line unless the employer has confirmed that the utility owner/operator has deenergized and (at the worksite) visibly grounded the power line.
- (d) *Assembly/disassembly inside Table A clearance prohibited.* No part of a crane/derrick, load line, or load (including rigging and lifting accessories), whether partially or fully assembled, is allowed closer than the minimum approach distance under Table A (see § 1926.1408) to a power line unless the employer has confirmed that the utility owner/operator has deenergized and (at the worksite) visibly grounded the power line.
- (e) *Voltage information.* Where Option (3) of this section is used, the utility owner/operator of the power lines must provide the requested voltage information within two working days of the employer's request.
- (f) *Power lines presumed energized.* The employer must assume that all power lines are energized unless the utility owner/operator confirms that the power line has been and continues to be deenergized and visibly grounded at the worksite.
- (g) *Posting of electrocution warnings.* There must be at least one electrocution hazard warning conspicuously posted in the cab so that it is in view of the operator and (except for overhead gantry and tower cranes) at least two on the outside of the equipment.

### § 1926.1408 Power line safety (up to 350 kV)—equipment operations

- (a) *Hazard assessments and precautions inside the work zone.* Before beginning equipment operations, the employer must:
  - (1) *Identify the work zone by either:*
    - (i) Demarcating boundaries (such as with flags, or a device such as a range limit device or range control warning device) and prohibiting the operator from operating the equipment past those boundaries, or
    - (ii) Defining the work zone as the area 360 degrees around the equipment, up to the equipment's maximum working radius.

- (2) Determine if any part of the equipment, load line or load (including rigging and lifting accessories), if operated up to the equipment's maximum working radius in the work zone, could get closer than 20 feet to a power line. If so, the employer must meet the requirements in Option (1), Option (2), or Option (3) of this section, as follows:
- (i) *Option (1)—Deenergize and ground.* Confirm from the utility owner/ operator that the power line has been deenergized and visibly grounded at the worksite.
  - (ii) *Option (2)—20 foot clearance.* Ensure that no part of the equipment, load line, or load (including rigging and lifting accessories), gets closer than 20 feet to the power line by implementing the measures specified in paragraph (b) of this section.
  - (iii) *Option (3)—Table A clearance.*
    - (A) Determine the line's voltage and the minimum approach distance permitted under Table A (see § 1926.1408).
    - (B) Determine if any part of the equipment, load line or load (including rigging and lifting accessories), while operating up to the equipment's maximum working radius in the work zone, could get closer than the minimum approach distance of the power line permitted under Table A (see § 1926.1408). If so, then the employer must follow the requirements in paragraph (b) of this section to ensure that no part of the equipment, load line, or load (including rigging and lifting accessories), gets closer to the line than the minimum approach distance.
- (b) *Preventing encroachment/electrocution.* Where encroachment precautions are required under Option (2) or Option (3) of this section, all of the following requirements must be met:
- (1) Conduct a planning meeting with the operator and the other workers who will be in the area of the equipment or load to review the location of the power line(s), and the steps that will be implemented to prevent encroachment/ electrocution.
  - (2) If tag lines are used, they must be non-conductive.
  - (3) Erect and maintain an elevated warning line, barricade, or line of signs, in view of the operator, equipped with flags or similar high-visibility markings, at 20 feet from the power line (if using Option (2) of this section) or at the minimum approach distance under Table A (see § 1926.1408) (if using Option (3) of this section). If the operator is unable to see the elevated warning line, a dedicated spotter must be used as described in § 1926.1408(b)(4)(ii) in addition to implementing one of the measures described in §§ 1926.1408(b)(4)(i), (iii), (iv) and (v).
- (4) Implement at least one of the following measures:
- (i) A proximity alarm set to give the operator sufficient warning to prevent encroachment.
  - (ii) A dedicated spotter who is in continuous contact with the operator. Where this measure is selected, the dedicated spotter must:
    - (A) Be equipped with a visual aid to assist in identifying the minimum clearance distance. Examples of a visual aid include, but are not limited to: A clearly visible line painted on the ground; a clearly visible line of stanchions; a set of clearly visible line-of-sight landmarks (such as a fence post behind the dedicated spotter and a building corner ahead of the dedicated spotter).
    - (B) Be positioned to effectively gauge the clearance distance.
    - (C) Where necessary, use equipment that enables the dedicated spotter to communicate directly with the operator.
    - (D) Give timely information to the operator so that the required clearance distance can be maintained.
  - (iii) A device that automatically warns the operator when to stop movement, such as a range control warning device. Such a device must be set to give the operator sufficient warning to prevent encroachment.
  - (iv) A device that automatically limits range of movement, set to prevent encroachment.
  - (v) An insulating link/device, as defined in § 1926.1401, installed at a point between the end of the load line (or below) and the load.
- (5) The requirements of paragraph (b)(4) of this section do not apply to work covered by subpart V of this part.
- (c) *Voltage information.* Where Option (3) of this section is used, the utility owner/operator of the power lines must provide the requested voltage information within two working days of the employer's request.
- (d) *Operations below power lines.*
- (1) No part of the equipment, load line, or load (including rigging and lifting accessories) is allowed below a power line unless the employer has confirmed that the utility owner/ operator has deenergized and (at the worksite) visibly grounded the power line, except where one of



the exceptions in paragraph (d)(2) of this section applies.

(2) *Exceptions.* Paragraph (d)(1) of this section is inapplicable where the employer demonstrates that one of the following applies:

- (i) The work is covered by subpart V of this part.
- (ii) For equipment with non-extensible booms: The uppermost part of the equipment, with the boom at true vertical, would be more than 20 feet below the plane of the power line or more than the Table A of this section minimum clearance distance below the plane of the power line.
- (iii) For equipment with articulating or extensible booms: The uppermost part of the equipment, with the boom in the fully extended position, at true vertical, would be more than 20 feet below the plane of the power line or more than the Table A of this section minimum clearance distance below the plane of the power line.
- (iv) The employer demonstrates that compliance with paragraph (d)(1) of this section is infeasible and meets the requirements of § 1926.1410.

(e) *Power lines presumed energized.* The employer must assume that all power lines are energized unless the utility owner/operator confirms that the power line has been and continues to be deenergized and visibly grounded at the worksite.

(f) When working near transmitter/ communication towers where the equipment is close enough for an electrical charge to be induced in the equipment or materials being handled, the transmitter must be deenergized or the following precautions must be taken:

- (1) The equipment must be provided with an electrical ground.
- (2) If tag lines are used, they must be non-conductive.

(g) *Training.*

(1) The employer must train each operator and crew member assigned to work with the equipment on all of the following:

- (i) The procedures to be followed in the event of electrical contact with a power line. Such training must include:
  - (A) Information regarding the danger of electrocution from the operator simultaneously touching the equipment and the ground.
  - (B) The importance to the operator's safety of remaining inside the cab except where there is an imminent danger of

fire, explosion, or other emergency that necessitates leaving the cab.

- (C) The safest means of evacuating from equipment that may be energized.
- (D) The danger of the potentially energized zone around the equipment (step potential).
- (E) The need for crew in the area to avoid approaching or touching the equipment and the load.
- (F) Safe clearance distance from power lines.
- (ii) Power lines are presumed to be energized unless the utility owner/operator confirms that the power line has been and continues to be deenergized and visibly grounded at the worksite
- (iii) Power lines are presumed to be uninsulated unless the utility owner/operator or a registered engineer who is a qualified person with respect to electrical power transmission and distribution confirms that a line is insulated.
- (iv) The limitations of an insulating link/ device, proximity alarm, and range control (and similar) device, if used.
- (v) The procedures to be followed to properly ground equipment and the limitations of grounding.

(2) Employees working as dedicated spotters must be trained to enable them to effectively perform their task, including training on the applicable requirements of this section.

(3) Training under this section must be administered in accordance with § 1926.1430(g).

(h) Devices originally designed by the manufacturer for use as: A safety device (*see* § 1926.1415), operational aid, or a means to prevent power line contact or electrocution, when used to comply with this section, must meet the manufacturer's procedures for use and conditions of use.

**TABLE A—MINIMUM CLEARANCE DISTANCES**

Voltage (nominal, kV, alternating current)	Minimum clearance distance (feet)
up to 50.....	10
over 50 to 200.....	15
over 200 to 350.....	20
over 350 to 500.....	25
over 500 to 750.....	35
over 750 to 1,000.....	45
over 1,000.....	(as established by the utility owner/operator or registered professional engineer who is a qualified person with respect to electrical power and distribution.)

**Note:** The value that follows “to” is up to and includes that value. For example, over 50 to 200 means up to and including 200kV.

**§ 1926.1409 Power line safety (over 350 kV)**

The requirements of § 1926.1407 and § 1926.1408 apply to power lines over 350 kV except:

- (a) For power lines at or below 1000 kV, wherever the distance “20 feet” is specified, the distance “50 feet” must be substituted; and
- (b) For power lines over 1000 kV, the minimum clearance distance must be established by the utility owner/ operator or registered professional engineer who is a qualified person with respect to electrical power transmission and distribution.

**§ 1926.1410 Power line safety (all voltages)—equipment operations closer than the Table A zone**

Equipment operations in which any part of the equipment, load line, or load (including rigging and lifting accessories) is closer than the minimum approach distance under Table A of § 1926.1408 to an energized power line is prohibited, except where the employer demonstrates that all of the following requirements are met:

- (a) The employer determines that it is infeasible to do the work without breaching the minimum approach distance under Table A of § 1926.1408.
- (b) The employer determines that, after consultation with the utility owner/operator, it is infeasible to deenergize and ground the power line or relocate the power line.
- (c) *Minimum clearance distance.*
  - (1) The power line owner/operator or registered professional engineer who is a qualified person with respect to electrical power transmission and distribution determines the minimum clearance distance that must be maintained to prevent electrical contact in light of the on-site

conditions. The factors that must be considered in making this determination include, but are not limited to: Conditions affecting atmospheric conductivity; time necessary to bring the equipment, load line, and load (including rigging and lifting accessories) to a complete stop; wind conditions; degree of sway in the power line; lighting conditions, and other conditions affecting the ability to prevent electrical contact.

- (2) Paragraph (c)(1) of this section does not apply to work covered by subpart V of this part; instead, for such work, the minimum clearance distances specified in § 1926.950 Table V-1 apply. Employers engaged in subpart V work are permitted to work closer than the distances in § 1926.950 Table V-1 where both the requirements of this section and § 1926.952(c)(3)(i) or (ii) are met.
- (d) A planning meeting with the employer and utility owner/operator (or registered professional engineer who is a qualified person with respect to electrical power transmission and distribution) is held to determine the procedures that will be followed to prevent electrical contact and electrocution. At a minimum these procedures must include:
  - (1) If the power line is equipped with a device that automatically reenergizes the circuit in the event of a power line contact, before the work begins, the automatic reclosing feature of the circuit interrupting device must be made inoperative if the design of the device permits.
  - (2) A dedicated spotter who is in continuous contact with the operator. The dedicated spotter must:
    - (i) Be equipped with a visual aid to assist in identifying the minimum clearance distance. Examples of a visual aid include, but are not limited to: A line painted on the ground; a clearly visible line of stanchions; a set of clearly visible line-of-sight landmarks (such as a fence post behind the dedicated spotter and a building corner ahead of the dedicated spotter).
    - (ii) Be positioned to effectively gauge the clearance distance.
    - (iii) Where necessary, use equipment that enables the dedicated spotter to communicate directly with the operator.
    - (iv) Give timely information to the operator so that the required clearance distance can be maintained.
  - (3) An elevated warning line, or barricade (not attached to the crane), in view of the operator (either directly or through video equipment), equipped with flags or similar high-visibility markings, to prevent electrical contact. However, this provision does not apply to work covered by subpart V of this part.

- (4) *Insulating link/device.*
- (i) An insulating link/device installed at a point between the end of the load line (or below) and the load.
  - (ii) For work covered by subpart V of this part, the requirement in paragraph (d)(4)(i) of this section applies only when working inside the § 1926.950 Table V-1 clearance distances.
  - (iii) For work covered by subpart V of this part involving operations where use of an insulating link/device is infeasible, the requirements of § 1910.269(p)(4)(iii)(B) or (C) may be substituted for the requirement in (d)(4)(i) of this section.
  - (iv) Until November 8, 2011, the following procedure may be substituted for the requirement in paragraph (d)(4)(i) of this section: All employees, excluding equipment operators located on the equipment, who may come in contact with the equipment, the load line, or the load must be insulated or guarded from the equipment, the load line, and the load. Insulating gloves rated for the voltage involved are adequate insulation for the purposes of this paragraph.
  - (v) Until November 8, 2013, the following procedure may be substituted for the requirement in (d)(4)(i) of this section:
    - (A) The employer must use a link/ device manufactured on or before November 8, 2011, that meets the definition of an insulating link/device, except that it has not been approved by a Nationally Recognized Testing Laboratory, and that is maintained and used in accordance with manufacturer requirements and recommendations, and is installed at a point between the end of the load line (or below) and the load; and
    - (B) All employees, excluding equipment operators located on the equipment, who may come in contact with the equipment, the load line, or the load must be insulated or guarded from the equipment, the load line, and the load through an additional means other than the device described in paragraph (d)(4)(v)(A) of this section. Insulating gloves rated for the voltage involved are adequate additional means of protection for the purposes of this paragraph.
- (5) Nonconductive rigging if the rigging may be within the Table A of § 1926.1408 distance during the operation.
- (6) If the equipment is equipped with a device that automatically limits range of movement, it must be used and set to prevent any part of the equipment, load line, or load (including rigging and lifting accessories) from breaching the minimum approach distance established under paragraph (c) of this section.
- (7) If a tag line is used, it must be of the nonconductive type.
  - (8) Barricades forming a perimeter at least 10 feet away from the equipment to prevent unauthorized personnel from entering the work area. In areas where obstacles prevent the barricade from being at least 10 feet away, the barricade must be as far from the equipment as feasible.
  - (9) Workers other than the operator must be prohibited from touching the load line above the insulating link/ device and crane. Operators remotely operating the equipment from the ground must use either wireless controls that isolate the operator from the equipment or insulating mats that insulate the operator from the ground.
  - (10) Only personnel essential to the operation are permitted to be in the area of the crane and load.
  - (11) The equipment must be properly grounded.
  - (12) Insulating line hose or cover-up must be installed by the utility owner/ operator except where such devices are unavailable for the line voltages involved.
- (e) The procedures developed to comply with paragraph (d) of this section are documented and immediately available on-site.
  - (f) The equipment user and utility owner/operator (or registered professional engineer) meet with the equipment operator and the other workers who will be in the area of the equipment or load to review the procedures that will be implemented to prevent breaching the minimum approach distance established in paragraph (c) of this section and prevent electrocution.
  - (g) The procedures developed to comply with paragraph (d) of this section are implemented.
  - (h) The utility owner/operator (or registered professional engineer) and all employers of employees involved in the work must identify one person who will direct the implementation of the procedures. The person identified in accordance with this paragraph must direct the implementation of the procedures and must have the authority to stop work at any time to ensure safety.
- (i) *[Reserved.]*
  - (j) If a problem occurs implementing the procedures being used to comply with paragraph (d) of this section, or indicating that those procedures are inadequate to prevent electrocution, the employer

must safely stop operations and either develop new procedures to comply with paragraph (d) of this section or have the utility owner/ operator deenergize and visibly ground or relocate the power line before resuming work.

(k) Devices originally designed by the manufacturer for use as a safety device (*see* § 1926.1415), operational aid, or a means to prevent power line contact or electrocution, when used to comply with this section, must comply with the manufacturer’s procedures for use and conditions of use.

(l) [*Reserved.*]

(m) The employer must train each operator and crew member assigned to work with the equipment in accordance with § 1926.1408(g).

**§ 1926.1411 Power line safety—while traveling under or near power lines with no load**

(a) This section establishes procedures and criteria that must be met for equipment traveling under or near a power line on a construction site with no load. Equipment traveling on a construction site with a load is governed by §§ 1926.1408, 1926.1409 or 1926.1410, whichever is appropriate, and § 1926.1417(u).

(b) The employer must ensure that:

(1) The boom/mast and boom/mast support system are lowered sufficiently to meet the requirements of this paragraph.

(2) The clearances specified in Table T of this section are maintained.

(3) The effects of speed and terrain on equipment movement (including movement of the boom/mast) are considered so that those effects do not cause the minimum clearance distances specified in Table T of this section to be breached.

(4) Dedicated spotter. If any part of the equipment while traveling will get closer than 20 feet to the power line, the employer must ensure that a dedicated spotter who is in continuous contact with the driver/operator is used. The dedicated spotter must:

- (i) Be positioned to effectively gauge the clearance distance.
- (ii) Where necessary, use equipment that enables the dedicated spotter to communicate directly with the operator.
- (iii) Give timely information to the operator so that the required clearance distance can be maintained.

(5) Additional precautions for traveling in poor visibility. When traveling at night, or in conditions of poor visibility, in addition to the measures

specified in paragraphs (b)(1) through (4) of this section, the employer must ensure that:

- (i) The power lines are illuminated or another means of identifying the location of the lines is used.
- (ii) A safe path of travel is identified and used.

**TABLE T—MINIMUM CLEARANCE DISTANCES WHILE TRAVELING WITH NO LOAD**

Voltage (nominal, kV, alternating current)	Minimum clearance distance (feet)
up to 0.75.....	4
over .75 to 50.....	6
over 50 to 345.....	10
over 345 to 750.....	16
over 750 to 1,000.....	20
over 1,000.....	(as established by the utility owner/operator or registered professional engineer who is a qualified person with respect to electrical power and distribution.)

**§ 1926.1412 Inspections.**

(a) *Modified equipment.*

(1) Equipment that has had modifications or additions which affect the safe operation of the equipment (such as modifications or additions involving a safety device or operational aid, critical part of a control system, power plant, braking system, load-sustaining structural components, load hook, or in-use operating mechanism) or capacity must be inspected by a qualified person after such modifications/additions have been completed, prior to initial use. The inspection must meet all of the following requirements:

- (i) The inspection must assure that the modifications or additions have been done in accordance with the approval obtained pursuant to § 1926.1434 (Equipment modifications).
- (ii) The inspection must include functional testing of the equipment.

(2) Equipment must not be used until an inspection under this paragraph demonstrates that the requirements of paragraph (a)(1)(i) of this section have been met.

(b) *Repaired/adjusted equipment.*

(1) Equipment that has had a repair or adjustment that relates to safe operation (such as: A repair or adjustment to a safety device or operator aid, or to a critical part of a control system, power plant, braking system, load-sustaining structural components, load hook, or in-use operating mechanism), must be inspected by a qualified

person after such a repair or adjustment has been completed, prior to initial use. The inspection must meet all of the following requirements:

- (i) The qualified person must determine if the repair/adjustment meets manufacturer equipment criteria (where applicable and available).
  - (ii) Where manufacturer equipment criteria are unavailable or inapplicable, the qualified person must:
    - (A) Determine if a registered professional engineer (RPE) is needed to develop criteria for the repair/ adjustment. If an RPE is not needed, the employer must ensure that the criteria are developed by the qualified person. If an RPE is needed, the employer must ensure that they are developed by an RPE.
    - (B) Determine if the repair/adjustment meets the criteria developed in accordance with paragraph (b)(1)(ii)(A) of this section.
  - (iii) The inspection must include functional testing of the repaired/ adjusted parts and other components that may be affected by the repair/adjustment.
  - (4) Equipment must not be used until an inspection under this paragraph demonstrates that the repair/adjustment meets the requirements of paragraph (b)(1)(i) of this section (or, where applicable, paragraph (b)(1)(ii) of this section).
- (c) *Post-assembly.*

- (1) Upon completion of assembly, the equipment must be inspected by a qualified person to assure that it is configured in accordance with manufacturer equipment criteria.
- (2) Where manufacturer equipment criteria are unavailable, a qualified person must:
  - (i) Determine if a registered professional engineer (RPE) familiar with the type of equipment involved is needed to develop criteria for the equipment configuration. If an RPE is not needed, the employer must ensure that the criteria are developed by the qualified person. If an RPE is needed, the employer must ensure that they are developed by an RPE.
  - (ii) Determine if the equipment meets the criteria developed in accordance with paragraph (c)(2)(i) of this section.
- (3) Equipment must not be used until an inspection under this paragraph demonstrates that the equipment is configured in accordance with the applicable criteria.

(d) *Each shift.*

- (1) A competent person must begin a visual inspection prior to each shift the equipment will be used, which must be completed before or during that shift. The inspection must consist of observation for apparent deficiencies. Taking apart equipment components and booming down is not required as part of this inspection unless the results of the visual inspection or trial operation indicate that further investigation necessitating taking apart equipment components or booming down is needed. Determinations made in conducting the inspection must be reassessed in light of observations made during operation. At a minimum the inspection must include all of the following:
  - (i) Control mechanisms for maladjustments interfering with proper operation.
  - (ii) Control and drive mechanisms for apparent excessive wear of components and contamination by lubricants, water or other foreign matter.
  - (iii) Air, hydraulic, and other pressurized lines for deterioration or leakage, particularly those which flex in normal operation.
  - (iv) Hydraulic system for proper fluid level.
  - (v) Hooks and latches for deformation, cracks, excessive wear, or damage such as from chemicals or heat.
  - (vi) Wire rope reeving for compliance with the manufacturer's specifications.
  - (vii) Wire rope, in accordance with § 1926.1413(a).
  - (viii) Electrical apparatus for malfunctioning, signs of apparent excessive deterioration, dirt or moisture accumulation.
  - (ix) Tires (when in use) for proper inflation and condition.
  - (x) Ground conditions around the equipment for proper support, including ground settling under and around outriggers/stabilizers and supporting foundations, ground water accumulation, or similar conditions. This paragraph does not apply to the inspection of ground conditions for railroad tracks and their underlying support when the railroad tracks are part of the general railroad system of transportation that is regulated pursuant to the Federal Railroad Administration under 49 CFR part 213.
  - (xi) The equipment for level position within the tolerances specified by the equipment manufacturer's recommendations, both before each shift and after each move and setup.
  - (xii) Operator cab windows for significant cracks, breaks, or other deficiencies that would hamper the operator's view.

- (xiii) Rails, rail stops, rail clamps and supporting surfaces when the equipment has rail traveling. This paragraph does not apply to the inspection of rails, rail stops, rail clamps and supporting surfaces when the railroad tracks are part of the general railroad system of transportation that is regulated pursuant to the Federal Railroad Administration under 49 CFR part 213.
  - (xiv) Safety devices and operational aids for proper operation.
- (2) If any deficiency in paragraphs (d)(1)(i) through (xiii) of this section (or in additional inspection items required to be checked for specific types of equipment in accordance with other sections of this standard) is identified, an immediate determination must be made by the competent person as to whether the deficiency constitutes a safety hazard. If the deficiency is determined to constitute a safety hazard, the equipment must be taken out of service until it has been corrected. *See* § 1926.1417.
  - (3) If any deficiency in paragraph (d)(1)(xiv) of this section (safety devices/operational aids) is identified, the action specified in § 1926.1415 and § 1926.1416 must be taken prior to using the equipment.
- (e) *Monthly.*
- (1) Each month the equipment is in service it must be inspected in accordance with paragraph (d) of this section (each shift).
  - (2) Equipment must not be used until an inspection under this paragraph demonstrates that no corrective action under paragraphs (d)(2) and (3) of this section is required.
  - (3) *Documentation.*
    - (i) The following information must be documented and maintained by the employer that conducts the inspection:
      - (A) The items checked and the results of the inspection.
      - (B) The name and signature of the person who conducted the inspection and the date.
    - (ii) This document must be retained for a minimum of three months.
- (f) *Annual/comprehensive.*
- (1) At least every 12 months the equipment must be inspected by a qualified person in accordance with paragraph (d) of this section (each shift) except that the corrective action set forth in paragraphs (f)(4), (f)(5), and (f)(6) of this section must apply in place of the corrective action required by paragraphs (d)(2) and (d)(3) of this section.
  - (2) In addition, at least every 12 months, the equipment must be inspected by a qualified person. Disassembly is required, as necessary, to complete the inspection. The equipment must be inspected for all of the following:
    - (i) Equipment structure (including the boom and, if equipped, the jib):
      - (A) Structural members: Deformed, cracked, or significantly corroded.
      - (B) Bolts, rivets and other fasteners: loose, failed or significantly corroded.
      - (C) Welds for cracks.
    - (ii) Sheaves and drums for cracks or significant wear.
    - (iii) Parts such as pins, bearings, shafts, gears, rollers and locking devices for distortion, cracks or significant wear.
    - (iv) Brake and clutch system parts, linings, pawls and ratchets for excessive wear.
    - (v) Safety devices and operational aids for proper operation (including significant inaccuracies).
    - (vi) Gasoline, diesel, electric, or other power plants for safety-related problems (such as leaking exhaust and emergency shut-down feature) and conditions, and proper operation.
    - (vii) Chains and chain drive sprockets for excessive wear of sprockets and excessive chain stretch.
    - (viii) Travel steering, brakes, and locking devices, for proper operation.
    - (ix) Tires for damage or excessive wear.
    - (x) Hydraulic, pneumatic and other pressurized hoses, fittings and tubing, as follows:
      - (A) Flexible hose or its junction with the fittings for indications of leaks.
      - (B) Threaded or clamped joints for leaks.
      - (C) Outer covering of the hose for blistering, abnormal deformation or other signs of failure/impending failure.
      - (D) Outer surface of a hose, rigid tube, or fitting for indications of excessive abrasion or scrubbing.
    - (xi) Hydraulic and pneumatic pumps and motors, as follows:
      - (A) Performance indicators: Unusual noises or vibration, low operating speed, excessive heating of the fluid, low pressure.
      - (B) Loose bolts or fasteners.
      - (C) Shaft seals and joints between pump sections for leaks.

- (xii) Hydraulic and pneumatic valves, as follows:
    - (A) Spools: Sticking, improper return to neutral, and leaks.
    - (B) Leaks.
    - (C) Valve housing cracks.
    - (D) Relief valves: Failure to reach correct pressure (if there is a manufacturer procedure for checking pressure, it must be followed).
  - (xiii) Hydraulic and pneumatic cylinders, as follows:
    - (A) Drifting caused by fluid leaking across the piston.
    - (B) Rod seals and welded joints for leaks.
    - (C) Cylinder rods for scores, nicks, or dents.
    - (D) Case (barrel) for significant dents.
    - (E) Rod eyes and connecting joints: Loose or deformed.
  - (xiv) Outrigger or stabilizer pads/ floats for excessive wear or cracks.
  - (xv) Slider pads for excessive wear or cracks.
  - (xvi) Electrical components and wiring for cracked or split insulation and loose or corroded terminations.
  - (xvii) Warning labels and decals originally supplied with the equipment by the manufacturer or otherwise required under this standard: Missing or unreadable.
  - (xviii) Originally equipped operator seat (or equivalent): Missing.
  - (xix) Operator seat: Unserviceable.
  - (xx) Originally equipped steps, ladders, handrails, guards: Missing.
  - (xxi) Steps, ladders, handrails, guards: In unusable/unsafe condition.
- (3) This inspection must include functional testing to determine that the equipment as configured in the inspection is functioning properly.
  - (4) If any deficiency is identified, an immediate determination must be made by the qualified person as to whether the deficiency constitutes a safety hazard or, though not yet a safety hazard, needs to be monitored in the monthly inspections.
  - (5) If the qualified person determines that a deficiency is a safety hazard, the equipment must be taken out of service until it has been corrected, except when temporary alternative measures are implemented as specified in § 1926.1416(d) or § 1926.1435(e). See § 1926.1417.
  - (6) If the qualified person determines that, though not presently a safety hazard, the deficiency needs to be monitored, the employer must ensure that the deficiency is checked in the monthly inspections.
- (7) *Documentation of annual/ comprehensive inspection.* The following information must be documented, maintained, and retained for a minimum of 12 months, by the employer that conducts the inspection:
    - (i) The items checked and the results of the inspection.
    - (ii) The name and signature of the person who conducted the inspection and the date.
  - (g) *Severe service.* Where the severity of use/conditions is such that there is a reasonable probability of damage or excessive wear (such as loading that may have exceeded rated capacity, shock loading that may have exceeded rated capacity, prolonged exposure to a corrosive atmosphere), the employer must stop using the equipment and a qualified person must:
    - (1) Inspect the equipment for structural damage to determine if the equipment can continue to be used safely.
    - (2) In light of the use/conditions determine whether any items/ conditions listed in paragraph (f) of this section need to be inspected; if so, the qualified person must inspect those items/ conditions.
    - (3) If a deficiency is found, the employer must follow the requirements in paragraphs (f)(4) through (6) of this section.
  - (h) *Equipment not in regular use.* Equipment that has been idle for 3 months or more must be inspected by a qualified person in accordance with the requirements of paragraph (e) (Monthly) of this section before initial use.
  - (i) *[Reserved.]*
  - (j) Any part of a manufacturer's procedures regarding inspections that relate to safe operation (such as to a safety device or operational aid, critical part of a control system, power plant, braking system, load-sustaining structural components, load hook, or in-use operating mechanism) that is more comprehensive or has a more frequent schedule of inspection than the requirements of this section must be followed.
  - (k) All documents produced under this section must be available, during the applicable document retention period, to all persons who conduct inspections under this section.
- § 1926.1413 Wire rope—inspection.**
- (a) *Shift inspection.*
    - (1) A competent person must begin a visual inspection prior to each shift the equipment is used, which must be completed before or during that

shift. The inspection must consist of observation of wire ropes (running and standing) that are likely to be in use during the shift for apparent deficiencies, including those listed in paragraph (a)(2) of this section. Untwisting (opening) of wire rope or booming down is not required as part of this inspection.

(2) *Apparent deficiencies.*

(i) *Category I.* Apparent deficiencies in this category include the following:

- (A) Significant distortion of the wire rope structure such as kinking, crushing, unstranding, birdcaging, signs of core failure or steel core protrusion between the outer strands.
- (B) Significant corrosion.
- (C) Electric arc damage (from a source other than power lines) or heat damage.
- (D) Improperly applied end connections.
- (E) Significantly corroded, cracked, bent, or worn end connections (such as from severe service).

(ii) *Category II.* Apparent deficiencies in this category are:

(A) Visible broken wires, as follows:

- (1) In running wire ropes: Six randomly distributed broken wires in one rope lay or three broken wires in one strand in one rope lay, where a rope lay is the length along the rope in which one strand makes a complete revolution around the rope.
- (2) In rotation resistant ropes: Two randomly distributed broken wires in six rope diameters or four randomly distributed broken wires in 30 rope diameters.
- (3) In pendants or standing wire ropes: More than two broken wires in one rope lay located in rope beyond end connections and/or more than one broken wire in a rope lay located at an end connection.

(B) A diameter reduction of more than 5% from nominal diameter.

(iii) *Category III.* Apparent deficiencies in this category include the following:

- (A) In rotation resistant wire rope, core protrusion or other distortion indicating core failure.
- (B) Prior electrical contact with a power line.
- (C) A broken strand.

(3) *Critical review items.* The competent person must give particular attention to all of the following:

- (i) Rotation resistant wire rope in use.
- (ii) Wire rope being used for boom hoists and luffing hoists, particularly at reverse bends.
- (iii) Wire rope at flange points, crossover points and repetitive pickup points on drums.
- (iv) Wire rope at or near terminal ends.
- (v) Wire rope in contact with saddles, equalizer sheaves or other sheaves where rope travel is limited.

(4) *Removal from service.*

(i) If a deficiency in Category I (*see* paragraph (a)(2)(i) of this section) is identified, an immediate determination must be made by the competent person as to whether the deficiency constitutes a safety hazard. If the deficiency is determined to constitute a safety hazard, operations involving use of the wire rope in question must be prohibited until:

- (A) The wire rope is replaced (*see* § 1926.1417), or
- (B) If the deficiency is localized, the problem is corrected by severing the wire rope in two; the undamaged portion may continue to be used. Joining lengths of wire rope by splicing is prohibited. If a rope is shortened under this paragraph, the employer must ensure that the drum will still have two wraps of wire when the load and/or boom is in its lowest position.

(ii) If a deficiency in Category II (*see* paragraph (a)(2)(ii) of this section) is identified, operations involving use of the wire rope in question must be prohibited until:

(A) The employer complies with the wire rope manufacturer's established criterion for removal from service or a different criterion that the wire rope manufacturer has approved in writing for that specific wire rope (*see* § 1926.1417),

(B) The wire rope is replaced (*see* § 1926.1417), or

(C) If the deficiency is localized, the problem is corrected by severing the wire rope in two; the undamaged portion may continue to be used. Joining lengths of wire rope by splicing is prohibited. If a rope is shortened under this paragraph, the employer must ensure that the drum will still have two wraps of wire when the load and/or boom is in its lowest position.

(iii) If a deficiency in Category III is identified, operations involving use of the wire rope in question must be prohibited until:



- (A) The wire rope is replaced (*see* § 1926.1417), or
  - (B) If the deficiency (other than power line contact) is localized, the problem is corrected by severing the wire rope in two; the undamaged portion may continue to be used. Joining lengths of wire rope by splicing is prohibited. Repair of wire rope that contacted an energized power line is also prohibited. If a rope is shortened under this paragraph, the employer must ensure that the drum will still have two wraps of wire when the load and/or boom is in its lowest position.
  - (iv) Where a wire rope is required to be removed from service under this section, either the equipment (as a whole) or the hoist with that wire rope must be tagged-out, in accordance with § 1926.1417(f)(1), until the wire rope is repaired or replaced.
- (b) *Monthly inspection.*
- (1) Each month an inspection must be conducted in accordance with paragraph (a) (shift inspection) of this section.
  - (2) The inspection must include any deficiencies that the qualified person who conducts the annual inspection determines under paragraph (c)(3)(ii) of this section must be monitored.
  - (3) Wire ropes on equipment must not be used until an inspection under this paragraph demonstrates that no corrective action under paragraph (a)(4) of this section is required.
  - (4) The inspection must be documented according to § 1926.1412(e)(3) (monthly inspection documentation).
- (c) *Annual/comprehensive.*
- (1) At least every 12 months, wire ropes in use on equipment must be inspected by a qualified person in accordance with paragraph (a) of this section (shift inspection).
  - (2) In addition, at least every 12 months, the wire ropes in use on equipment must be inspected by a qualified person, as follows:
    - (i) The inspection must be for deficiencies of the types listed in paragraph (a)(2) of this section.
    - (ii) The inspection must be complete and thorough, covering the surface of the entire length of the wire ropes, with particular attention given to all of the following:
      - (A) Critical review items listed in paragraph (a)(3) of this section.
      - (B) Those sections that are normally hidden during shift and monthly inspections.
      - (C) Wire rope subject to reverse bends.
      - (D) Wire rope passing over sheaves.
- (iii) *Exception:* In the event an inspection under paragraph (c)(2) of this section is not feasible due to existing set-up and configuration of the equipment (such as where an assist crane is needed) or due to site conditions (such as a dense urban setting), such inspections must be conducted as soon as it becomes feasible, but no longer than an additional 6 months for running ropes and, for standing ropes, at the time of disassembly.
- (3) If a deficiency is identified, an immediate determination must be made by the qualified person as to whether the deficiency constitutes a safety hazard.
- (i) If the deficiency is determined to constitute a safety hazard, operations involving use of the wire rope in question must be prohibited until:
    - (A) The wire rope is replaced (*see* § 1926.1417), or
    - (B) If the deficiency is localized, the problem is corrected by severing the wire rope in two; the undamaged portion may continue to be used. Joining lengths of wire rope by splicing is prohibited. If a rope is shortened under this paragraph, the employer must ensure that the drum will still have two wraps of wire when the load and/or boom is in its lowest position.
  - (ii) If the qualified person determines that, though not presently a safety hazard, the deficiency needs to be monitored, the employer must ensure that the deficiency is checked in the monthly inspections.
- (4) The inspection must be documented according to § 1926.1412(f)(7) (annual/ comprehensive inspection documentation).
- (d) Rope lubricants that are of the type that hinder inspection must not be used.
- (e) All documents produced under this section must be available, during the applicable document retention period, to all persons who conduct inspections under this section.
- § 1926.1414 Wire rope—selection and installation criteria.**
- (a) Original equipment wire rope and replacement wire rope must be selected and installed in accordance with the requirements of this section. Selection of replacement wire rope must be in accordance with the recommendations of the wire rope manufacturer, the equipment manufacturer, or a qualified person.

(b) *Wire rope design criteria:* Wire rope (other than rotation resistant rope) must comply with either Option (1) or Option (2) of this section, as follows:

(1) *Option (1).* Wire rope must comply with section 5-1.7.1 of ASME B30.5- 2004 (incorporated by reference, *see* § 1926.6) except that section's paragraph (c) must not apply.

(2) *Option (2).* Wire rope must be designed to have, in relation to the equipment's rated capacity, a sufficient minimum breaking force and design factor so that compliance with the applicable inspection provisions in § 1926.1413 will be an effective means of preventing sudden rope failure.

(c) Wire rope must be compatible with the safe functioning of the equipment.

(d) *Boom hoist reeving.*

(1) Fiber core ropes must not be used for boom hoist reeving, except for derricks.

(2) Rotation resistant ropes must be used for boom hoist reeving only where the requirements of paragraph (e)(4)(ii) of this section are met.

(e) *Rotation resistant ropes.*

(1) *Definitions.*

(i) Type I rotation resistant wire rope ("Type I"). Type I rotation resistant rope is stranded rope constructed to have little or no tendency to rotate or, if guided, transmits little or no torque. It has at least 15 outer strands and comprises an assembly of at least three layers of strands laid helically over a center in two operations. The direction of lay of the outer strands is opposite to that of the underlying layer.

(ii) Type II rotation resistant wire rope ("Type II"). Type II rotation resistant rope is stranded rope constructed to have significant resistance to rotation. It has at least 10 outer strands and comprises an assembly of two or more layers of strands laid helically over a center in two or three operations. The direction of lay of the outer strands is opposite to that of the underlying layer.

(iii) Type III rotation resistant wire rope ("Type III"). Type III rotation resistant rope is stranded rope constructed to have limited resistance to rotation. It has no more than nine outer strands, and comprises an assembly of two layers of strands laid helically over a center in two operations. The direction of lay of the outer strands is opposite to that of the underlying layer.

(2) *Requirements.*

(i) Types II and III with an operating design factor of less than 5 must not be used for duty cycle or repetitive lifts.

(ii) Rotation resistant ropes (including Types I, II and III) must have an operating design factor of no less than 3.5.

(iii) Type I must have an operating design factor of no less than 5, except where the wire rope manufacturer and the equipment manufacturer approves the design factor, in writing.

(iv) Types II and III must have an operating design factor of no less than 5, except where the requirements of paragraph (e)(3) of this section are met.

(3) When Types II and III with an operating design factor of less than 5 are used (for non-duty cycle, non-repetitive lifts), the following requirements must be met for each lifting operation:

(i) A qualified person must inspect the rope in accordance with § 1926.1413(a). The rope must be used only if the qualified person determines that there are no deficiencies constituting a hazard. In making this determination, more than one broken wire in any one rope lay must be considered a hazard.

(ii) Operations must be conducted in such a manner and at such speeds as to minimize dynamic effects.

(iii) Each lift made under § 1926.1414(e)(3) must be recorded in the monthly and annual inspection documents. Such prior uses must be considered by the qualified person in determining whether to use the rope again.

(4) *Additional requirements for rotation resistant ropes for boom hoist reeving.*

(i) Rotation resistant ropes must not be used for boom hoist reeving, except where the requirements of paragraph (e)(4)(ii) of this section are met.

(ii) Rotation resistant ropes may be used as boom hoist reeving when load hoists are used as boom hoists for attachments such as luffing attachments or boom and mast attachment systems. Under these conditions, all of the following requirements must be met:

(A) The drum must provide a first layer rope pitch diameter of not less than 18 times the nominal diameter of the rope used.

(B) The requirements in § 1926.1426(a) (irrespective of the date of manufacture of the equipment), and § 1926.1426(b).

(C) The requirements in ASME B30.5- 2004 sections 5-1.3.2(a), (a)(2) through (a)(4), (b) and (d) (incorporated by reference, *see* § 1926.6) except that the minimum

pitch diameter for sheaves used in multiple rope reeving is 18 times the nominal diameter of the rope used (instead of the value of 16 specified in section 5-1.3.2(d)).

- (D) All sheaves used in the boom hoist reeving system must have a rope pitch diameter of not less than 18 times the nominal diameter of the rope used.
- (E) The operating design factor for the boom hoist reeving system must be not less than five.
- (F) The operating design factor for these ropes must be the total minimum breaking force of all parts of rope in the system divided by the load imposed on the rope system when supporting the static weights of the structure and the load within the equipment's rated capacity.
- (G) When provided, a power-controlled lowering system must be capable of handling rated capacities and speeds as specified by the manufacturer.

- (f) Wire rope clips used in conjunction with wedge sockets must be attached to the unloaded dead end of the rope only, except that the use of devices specifically designed for dead-ending rope in a wedge socket is permitted.
- (g) Socketing must be done in the manner specified by the manufacturer of the wire rope or fitting.
- (h) Prior to cutting a wire rope, seizings must be placed on each side of the point to be cut. The length and number of seizings must be in accordance with the wire rope manufacturer's instructions.

### § 1926.1415 Safety devices.

- (a) *Safety devices.* The following safety devices are required on all equipment covered by this subpart, unless otherwise specified:
  - (1) *Crane level indicator.*
    - (i) The equipment must have a crane level indicator that is either built into the equipment or is available on the equipment.
    - (ii) If a built-in crane level indicator is not working properly, it must be tagged-out or removed. If a removable crane level indicator is not working properly, it must be removed.
    - (iii) This requirement does not apply to portal cranes, derricks, floating cranes/derricks and land cranes/ derricks on barges, pontoons, vessels or other means of flotation.
  - (2) Boom stops, except for derricks and hydraulic booms.
  - (3) Jib stops (if a jib is attached), except for derricks.

- (4) Equipment with foot pedal brakes must have locks.
- (5) Hydraulic outrigger jacks and hydraulic stabilizer jacks must have an integral holding device/ check valve.
- (6) Equipment on rails must have rail clamps and rail stops, except for portal cranes.
- (7) *Horn*
  - (i) The equipment must have a horn that is either built into the equipment or is on the equipment and immediately available to the operator.
  - (ii) If a built-in horn is not working properly, it must be tagged-out or removed. If a removable horn is not working properly, it must be removed.
- (b) *Proper operation required.* Operations must not begin unless all of the devices listed in this section are in proper working order. If a device stops working properly during operations, the operator must safely stop operations. If any of the devices listed in this section are not in proper working order, the equipment must be taken out of service and operations must not resume until the device is again working properly. *See* § 1926.1417 (Operation). Alternative measures are not permitted to be used.

### § 1926.1416 Operational aids.

- (a) The devices listed in this section ("listed operational aids") are required on all equipment covered by this subpart, unless otherwise specified.
  - (1) The requirements in paragraphs (e)(1), (e)(2), and (e)(3) of this section do not apply to articulating cranes.
  - (2) The requirements in paragraphs (d)(3), (e)(1), and (e)(4) of this section apply only to those digger derricks manufactured after November 8, 2011.
- (b) Operations must not begin unless the listed operational aids are in proper working order, except where an operational aid is being repaired the employer uses the specified temporary alternative measures. The time periods permitted for repairing defective operational aids are specified in paragraphs (d) and (e) of this section. More protective alternative measures specified by the crane/derrick manufacturer, if any, must be followed.
- (c) If a listed operational aid stops working properly during operations, the operator must safely stop operations until the temporary alternative measures are implemented or the device is again working properly. If a replacement part is no longer available, the use of a substitute device that performs the same type of function is permitted and is not considered a modification under § 1926.1434.

- (d) *Category I operational aids and alternative measures.* Operational aids listed in this paragraph that are not working properly must be repaired no later than 7 calendar days after the deficiency occurs. Exception: If the employer documents that it has ordered the necessary parts within 7 calendar days of the occurrence of the deficiency, the repair must be completed within 7 calendar days of receipt of the parts. See § 1926.1417(j) for additional requirements.
- (1) *Boom hoist limiting device.*
- (iii) (i) For equipment manufactured after December 16, 1969, a boom hoist limiting device is required. *Temporary alternative measures (use at least one).* One or more of the following methods must be used:
- (A) (A) Use a boom angle indicator.
- (B) (B) Clearly mark the boom hoist cable (so that it can easily be seen by the operator) at a point that will give the operator sufficient time to stop the hoist to keep the boom within the minimum allowable radius. In addition, install mirrors or remote video cameras and displays if necessary for the operator to see the mark.
- (C) (C) Clearly mark the boom hoist cable (so that it can easily be seen by a spotter) at a point that will give the spotter sufficient time to signal the operator and have the operator stop the hoist to keep the boom within the minimum allowable radius.
- (iv) (ii) If the equipment was manufactured on or before December 16, 1969, and is not equipped with a boom hoist limiting device, at least one of the measures in paragraphs (d)(1)(i)(A) through (C) of this section must be used.
- (2) *Luffing jib limiting device.* Equipment with a luffing jib must have a luffing jib limiting device. Temporary alternative measures are the same as in paragraph (d)(1)(i) of this section, except to limit the movement of the luffing jib rather than the boom hoist.
- (3) *Anti two-blocking device.*
- (v) (i) Telescopic boom cranes manufactured after February 28, 1992, must be equipped with a device which automatically prevents damage from contact between the load block, overhaul ball, or similar component, and the boom tip (or fixed upper block or similar component). The device(s) must prevent such damage at all points where two-blocking could occur.
- (vi) *Temporary alternative measures:* Clearly mark the cable (so that it can easily be seen by the operator) at a point that will give the operator sufficient time to stop the hoist to prevent two-blocking, and use a spotter when extending the boom.
- (vii) (ii) *Lattice boom cranes.*
- (A) (A) Lattice boom cranes manufactured after Feb 28, 1992, must be equipped with a device that either automatically prevents damage and load failure from contact between the load block, overhaul ball, or similar component, and the boom tip (or fixed upper block or similar component), or warns the operator in time for the operator to prevent two-blocking. The device must prevent such damage/failure or provide adequate warning for all points where two-blocking could occur.
- (B) (B) Lattice boom cranes and derricks manufactured after November 8, 2011 must be equipped with a device which automatically prevents damage and load failure from contact between the load block, overhaul ball, or similar component, and the boom tip (or fixed upper block or similar component). The device(s) must prevent such damage/failure at all points where two-blocking could occur.
- (C) (C) *Exception.* The requirements in paragraphs (d)(3)(ii)(A) and (B) of this section do not apply to such lattice boom equipment when used for dragline, clamshell (grapple), magnet, drop ball, container handling, concrete bucket, marine operations that do not involve hoisting personnel, and pile driving work.
- (D) (D) *Temporary alternative measures.* Clearly mark the cable (so that it can easily be seen by the operator) at a point that will give the operator sufficient time to stop the hoist to prevent two-blocking, or use a spotter.
- (viii) (iii) Articulating cranes manufactured after December 31, 1999, that are equipped with a load hoist must be equipped with a device that automatically prevents damage from contact between the load block, overhaul ball, or similar component, and the boom tip (or fixed upper block or similar component). The device must prevent such damage at all points where two-blocking could occur. *Temporary alternative measures:* When two-blocking could only occur with movement of the load hoist, clearly mark the cable (so

that it can easily be seen by the operator) at a point that will give the operator sufficient time to stop the hoist to prevent two-blocking, or use a spotter. When two-blocking could occur without movement of the load hoist, clearly mark the cable (so that it can easily be seen by the operator) at a point that will give the operator sufficient time to stop the hoist to prevent two-blocking, and use a spotter when extending the boom.

(e) *Category II operational aids and alternative measures.* Operational aids listed in this paragraph that are not working properly must be repaired no later than 30 calendar days after the deficiency occurs. Exception: If the employer documents that it has ordered the necessary parts within 7 calendar days of the occurrence of the deficiency, and the part is not received in time to complete the repair in 30 calendar days, the repair must be completed within 7 calendar days of receipt of the parts. See § 1926.1417(j) for additional requirements.

(1) *Boom angle or radius indicator.* The equipment must have a boom angle or radius indicator readable from the operator's station. *Temporary alternative measures:* Radii or boom angle must be determined by measuring the radii or boom angle with a measuring device.

(2) *Jib angle indicator* if the equipment has a luffing jib. *Temporary alternative measures:* Radii or jib angle must be determined by ascertaining the main boom angle and then measuring the radii or jib angle with a measuring device.

(3) *Boom length indicator* if the equipment has a telescopic boom, except where the rated capacity is independent of the boom length. *Temporary alternative measures.* One or more of the following methods must be used:

- (ix) (i) Mark the boom with measured marks to calculate boom length,
- (x) (ii) Calculate boom length from boom angle and radius measurements,
- (xi) (iii) Measure the boom with a measuring device.

(4) *Load weighing and similar devices.*

(xii) (i) Equipment (other than derricks and articulating cranes) manufactured after March 29, 2003 with a rated capacity over 6,000 pounds must have at least one of the following: load weighing device, load moment (or rated capacity) indicator, or load moment (or rated capacity) limiter. *Temporary alternative measures:* The weight of the load must be determined from a source recognized by the industry (such as the load's manufacturer) or by a calculation method recognized by the industry (such as calculating a steel beam

from measured dimensions and a known per foot weight). This information must be provided to the operator prior to the lift.

(xiii) (ii) Articulating cranes manufactured after November 8, 2011 must have at least one of the following: automatic overload prevention device, load weighing device, load moment (or rated capacity) indicator, or load moment (rated capacity) limiter. *Temporary alternative measures:* The weight of the load must be determined from a source recognized by the industry (such as the load's manufacturer) or by a calculation method recognized by the industry (such as calculating a steel beam from measured dimensions and a known per foot weight). This information must be provided to the operator prior to the lift.

(5) The following devices are required on equipment manufactured after November 8, 2011:

(xiv) (i) Outrigger/stabilizer position (horizontal beam extension) sensor/ monitor if the equipment has outriggers or stabilizers. *Temporary alternative measures:* The operator must verify that the position of the outriggers or stabilizers is correct (in accordance with manufacturer procedures) before beginning operations requiring outrigger or stabilizer deployment.

(xv) (ii) Hoist drum rotation indicator if the equipment has a hoist drum not visible from the operator's station. *Temporary alternative measures:* Mark the drum to indicate the rotation of the drum. In addition, install mirrors or remote video cameras and displays if necessary for the operator to see the mark.

## § 1926.1417 Operation.

(a) The employer must comply with all manufacturer procedures applicable to the operational functions of equipment, including its use with attachments.

(b) *Unavailable operation procedures.*

(1) Where the manufacturer procedures are unavailable, the employer must develop and ensure compliance with all procedures necessary for the safe operation of the equipment and attachments.

(2) Procedures for the operational controls must be developed by a qualified person.

(3) Procedures related to the capacity of the equipment must be developed and signed by a registered professional engineer familiar with the equipment.

(c) *Accessibility of procedures.*

(1) The procedures applicable to the operation of the equipment, including rated capacities (load

charts), recommended operating speeds, special hazard warnings, instructions, and operator's manual, must be readily available in the cab at all times for use by the operator.

- (2) Where rated capacities are available in the cab only in electronic form: In the event of a failure which makes the rated capacities inaccessible, the operator must immediately cease operations or follow safe shut-down procedures until the rated capacities (in electronic or other form) are available.
- (d) The operator must not engage in any practice or activity that diverts his/ her attention while actually engaged in operating the equipment, such as the use of cellular phones (other than when used for signal communications).
- (e) *Leaving the equipment unattended.*
  - (1) The operator must not leave the controls while the load is suspended, except where all of the following are met:
    - (xvi) (i) The operator remains adjacent to the equipment and is not engaged in any other duties.
    - (xvii) (ii) The load is to be held suspended for a period of time exceeding normal lifting operations.
    - (xviii) (iii) The competent person determines that it is safe to do so and implements measures necessary to restrain the boom hoist and telescoping, load, swing, and outrigger or stabilizer functions.
    - (xix) (iv) Barricades or caution lines, and notices, are erected to prevent all employees from entering the fall zone. No employees, including those listed in §§ 1926.1425(b)(1) through (3), § 1926.1425(d) or § 1926.1425(e), are permitted in the fall zone.
  - (2) The provisions in § 1926.1417(e)(1) do not apply to working gear (such as slings, spreader bars, ladders, and welding machines) where the weight of the working gear is negligible relative to the lifting capacity of the equipment as positioned, and the working gear is suspended over an area other than an entrance or exit.
- (f) *Tag-out.*
  - (1) *Tagging out of service equipment/ functions.*

Where the employer has taken the equipment out of service, a tag must be placed in the cab stating that the equipment is out of service and is not to be used. Where the employer has taken a function(s) out of service, a tag must be placed in a conspicuous position stating that the function is out of service and is not to be used.
  - (2) *Response to "do not operate"/tag-out signs.*

- (xx) (i) If there is a warning (tag-out or maintenance/do not operate) sign on the equipment or starting control, the operator must not activate the switch or start the equipment until the sign has been removed by a person authorized to remove it, or until the operator has verified that:
  - (A) (A) No one is servicing, working on, or otherwise in a dangerous position on the machine.
  - (B) (B) The equipment has been repaired and is working properly.
- (xxi) (ii) If there is a warning (tag-out or maintenance/do not operate) sign on any other switch or control, the operator must not activate that switch or control until the sign has been removed by a person authorized to remove it, or until the operator has verified that the requirements in paragraphs (f)(2)(i)(A) and (B) of this section have been met.
- (g) Before starting the engine, the operator must verify that all controls are in the proper starting position and that all personnel are in the clear.
- (h) *Storm warning.* When a local storm warning has been issued, the competent person must determine whether it is necessary to implement manufacturer recommendations for securing the equipment.
- (i) *[Reserved.]*
- (j) If equipment adjustments or repairs are necessary:
  - (1) The operator must, in writing, promptly inform the person designated by the employer to receive such information and, where there are successive shifts, to the next operator; and
  - (2) The employer must notify all affected employees, at the beginning of each shift, of the necessary adjustments or repairs and all alternative measures.
- (k) Safety devices and operational aids must not be used as a substitute for the exercise of professional judgment by the operator.
- (l) *[Reserved.]*
- (m) If the competent person determines that there is a slack rope condition requiring re-spooling of the rope, it must be verified (before starting to lift) that the rope is seated on the drum and in the sheaves as the slack is removed.
- (n) The competent person must adjust the equipment and/or operations to address the effect of wind, ice, and snow on equipment stability and rated capacity.
- (o) *Compliance with rated capacity.*
  - (1) The equipment must not be operated in excess of its rated capacity.

- (2) The operator must not be required to operate the equipment in a manner that would violate paragraph (o)(1) of this section.
- (3) *Load weight.* The operator must verify that the load is within the rated capacity of the equipment by at least one of the following methods:
- (xxii) (i) The weight of the load must be determined from a source recognized by the industry (such as the load's manufacturer), or by a calculation method recognized by the industry (such as calculating a steel beam from measured dimensions and a known per foot weight), or by other equally reliable means. In addition, when requested by the operator, this information must be provided to the operator prior to the lift; or
- (xxiii) (ii) The operator must begin hoisting the load to determine, using a load weighing device, load moment indicator, rated capacity indicator, or rated capacity limiter, if it exceeds 75 percent of the maximum rated capacity at the longest radius that will be used during the lift operation. If it does, the operator must not proceed with the lift until he/she verifies the weight of the load in accordance with paragraph (o)(3)(i) of this section.
- (p) The boom or other parts of the equipment must not contact any obstruction.
- (q) The equipment must not be used to drag or pull loads sideways.
- (r) On wheel-mounted equipment, no loads must be lifted over the front area, except as permitted by the manufacturer.
- (s) The operator must test the brakes each time a load that is 90% or more of the maximum line pull is handled by lifting the load a few inches and applying the brakes. In duty cycle and repetitive lifts where each lift is 90% or more of the maximum line pull, this requirement applies to the first lift but not to successive lifts.
- (t) Neither the load nor the boom must be lowered below the point where less than two full wraps of rope remain on their respective drums.
- (u) *Traveling with a load.*
- (1) Traveling with a load is prohibited if the practice is prohibited by the manufacturer.
- (2) Where traveling with a load, the employer must ensure that:
- (xxiv) (i) A competent person supervises the operation, determines if it is necessary to reduce rated capacity, and makes determinations regarding load position, boom location, ground support, travel route, overhead obstructions, and speed of movement necessary to ensure safety.
- (xxv) (ii) The determinations of the competent person required in paragraph (u)(2)(i) of this section are implemented.
- (xxvi) (iii) For equipment with tires, tire pressure specified by the manufacturer is maintained.
- (v) Rotational speed of the equipment must be such that the load does not swing out beyond the radius at which it can be controlled.
- (w) A tag or restraint line must be used if necessary to prevent rotation of the load that would be hazardous.
- (x) The brakes must be adjusted in accordance with manufacturer procedures to prevent unintended movement.
- (y) The operator must obey a stop (or emergency stop) signal, irrespective of who gives it.
- (z) *Swinging locomotive cranes.* A locomotive crane must not be swung into a position where railway cars on an adjacent track could strike it, until it is determined that cars are not being moved on the adjacent track and that proper flag protection has been established.
- (aa) *Counterweight/ballast.*
- (1) The following applies to equipment other than tower cranes:
- (xxvii) (i) Equipment must not be operated without the counterweight or ballast in place as specified by the manufacturer.
- (xxviii) (ii) The maximum counterweight or ballast specified by the manufacturer for the equipment must not be exceeded.
- (2) Counterweight/ballast requirements for tower cranes are specified in § 1926.1435(b)(8).

### § 1926.1418 Authority to stop operation.

Whenever there is a concern as to safety, the operator must have the authority to stop and refuse to handle loads until a qualified person has determined that safety has been assured.

### § 1926.1419 Signals—general requirements.

- (a) A signal person must be provided in each of the following situations:
- (1) The point of operation, meaning the load travel or the area near or at load placement, is not in full view of the operator.
- (2) When the equipment is traveling, the view in the direction of travel is obstructed.
- (3) Due to site specific safety concerns, either the operator or the person handling the load determines that it is necessary.

- (b) *Types of signals.* Signals to operators must be by hand, voice, audible, or new signals.
- (c) *Hand signals.*
  - (1) When using hand signals, the Standard Method must be used (see Appendix A of this subpart). *Exception:* Where use of the Standard Method for hand signals is infeasible, or where an operation or use of an attachment is not covered in the Standard Method, non-standard hand signals may be used in accordance with paragraph (c) (2) of this section.
  - (2) *Non-standard hand signals.* When using non-standard hand signals, the signal person, operator, and lift director (where there is one) must contact each other prior to the operation and agree on the non-standard hand signals that will be used.
- (d) *New signals.* Signals other than hand, voice, or audible signals may be used where the employer demonstrates that:
  - (1) The new signals provide at least equally effective communication as voice, audible, or Standard Method hand signals, or
  - (2) The new signals comply with a national consensus standard that provides at least equally effective communication as voice, audible, or Standard Method hand signals.
- (e) *Suitability.* The signals used (hand, voice, audible, or new), and means of transmitting the signals to the operator (such as direct line of sight, video, radio, etc.), must be appropriate for the site conditions.
- (f) During operations requiring signals, the ability to transmit signals between the operator and signal person must be maintained. If that ability is interrupted at any time, the operator must safely stop operations requiring signals until it is reestablished and a proper signal is given and understood.
- (g) If the operator becomes aware of a safety problem and needs to communicate with the signal person, the operator must safely stop operations. Operations must not resume until the operator and signal person agree that the problem has been resolved.
- (h) Only one person may give signals to a crane/derrick at a time, except in circumstances covered by paragraph (j) of this section.
- (i) *[Reserved.]*
- (j) Anyone who becomes aware of a safety problem must alert the operator or signal person by giving the stop or emergency stop signal. (**Note:** § 1926.1417(y) requires the operator to obey a stop or emergency stop signal).
- (k) All directions given to the operator by the signal person must be given from the operator's direction perspective.

- (l) *[Reserved.]*
- (m) *Communication with multiple cranes/derricks.* Where a signal person(s) is in communication with more than one crane/derrick, a system must be used for identifying the crane/ derrick each signal is for, as follows:
  - (1) for each signal, prior to giving the function/ direction, the signal person must identify the crane/derrick the signal is for, or
  - (2) must use an equally effective method of identifying which crane/ derrick the signal is for.

### § 1926.1420 Signals—radio, telephone or other electronic transmission of signals.

- (a) The device(s) used to transmit signals must be tested on site before beginning operations to ensure that the signal transmission is effective, clear, and reliable.
- (b) Signal transmission must be through a dedicated channel, except:
  - (1) Multiple cranes/derricks and one or more signal persons may share a dedicated channel for the purpose of coordinating operations.
  - (2) Where a crane is being operated on or adjacent to railroad tracks, and the actions of the crane operator need to be coordinated with the movement of other equipment or trains on the same or adjacent tracks.
- (c) The operator's reception of signals must be by a hands-free system.

### § 1926.1421 Signals—voice signals—additional requirements.

- (a) Prior to beginning operations, the operator, signal person and lift director (if there is one), must contact each other and agree on the voice signals that will be used. Once the voice signals are agreed upon, these workers need not meet again to discuss voice signals unless another worker is added or substituted, there is confusion about the voice signals, or a voice signal is to be changed.
- (b) Each voice signal must contain the following three elements, given in the following order: function (such as hoist, boom, etc.), direction; distance and/or speed; function, stop command.
- (c) The operator, signal person and lift director (if there is one), must be able to effectively communicate in the language used.

### § 1926.1422 Signals—hand signal chart.

Hand signal charts must be either posted on the equipment or conspicuously posted in the vicinity of the hoisting operations.



## § 1926.1423 Fall protection.

### (a) Application.

- (1) Paragraphs (b), (c)(3), (e) and (f) of this section apply to all equipment covered by this subpart except tower cranes.
- (2) Paragraphs (c)(1), (c)(2), (d), (g), (j) and (k) of this section apply to all equipment covered by this subpart.
- (3) Paragraphs (c)(4) and (h) of this section apply only to tower cranes.

### (b) Boom walkways.

- (1) Equipment manufactured after November 8, 2011 with lattice booms must be equipped with walkways on the boom(s) if the vertical profile of the boom (from cord centerline to cord centerline) is 6 or more feet.
- (2) *Boom walkway criteria.*
  - (i) The walkways must be at least 12 inches wide.
  - (ii) Guardrails, railings and other permanent fall protection attachments along walkways are:
    - (A) Not required.
    - (B) Prohibited on booms supported by pendant ropes or bars if the guardrails/railings/attachments could be snagged by the ropes or bars.
    - (C) Prohibited if of the removable type (designed to be installed and removed each time the boom is assembled/disassembled).
    - (D) Where not prohibited, guardrails or railings may be of any height up to, but not more than, 45 inches.

### (c) Steps, handholds, ladders, grabrails, guardrails and railings.

- (1) Section 1926.502(b) does not apply to equipment covered by this subpart.
- (2) The employer must maintain in good condition originally-equipped steps, handholds, ladders and guardrails/railings/grabrails.
- (3) Equipment manufactured after November 8, 2011 must be equipped so as to provide safe access and egress between the ground and the operator work station(s), including the forward and rear positions, by the provision of devices such as steps, handholds, ladders, and guardrails/railings/grabrails. These devices must meet the following criteria:
  - (i) Steps, handholds, ladders and guardrails/railings/grabrails must meet the criteria of SAE J185 (May 2003) (incorporated by reference, *see* § 1926.6) or ISO 11660-2:1994(E) (incorporated by reference, *see* § 1926.6) except where infeasible.

- (ii) Walking/stepping surfaces, except for crawler treads, must have slip-resistant features/properties (such as diamond plate metal, strategically placed grip tape, expanded metal, or slip-resistant paint).

- (4) Tower cranes manufactured after November 8, 2011 must be equipped so as to provide safe access and egress between the ground and the cab, machinery platforms, and tower (mast), by the provision of devices such as steps, handholds, ladders, and guardrails/railings/grabrails. These devices must meet the following criteria:

- (i) Steps, handholds, ladders, and guardrails/railings/grabrails must meet the criteria of ISO 11660-1:2008(E) (incorporated by reference, *see* § 1926.6) and ISO 11660-3:2008(E) (incorporated by reference, *see* § 1926.6) or SAE J185 (May 2003) (incorporated by reference, *see* § 1926.6) except where infeasible.
- (ii) Walking/stepping surfaces must have slip-resistant features/properties (such as diamond plate metal, strategically placed grip tape, expanded metal, or slip-resistant paint).

- (d) *Personal fall arrest and fall restraint systems.* Personal fall arrest system components must be used in personal fall arrest and fall restraint systems and must conform to the criteria in § 1926.502(d) except that § 1926.502(d)(15) does not apply to components used in personal fall arrest and fall restraint systems. Either body belts or body harnesses must be used in personal fall arrest and fall restraint systems.

- (e) For non-assembly/disassembly work, the employer must provide and ensure the use of fall protection equipment for employees who are on a walking/working surface with an unprotected side or edge more than 6 feet above a lower level as follows:

- (1) When moving point-to-point:

- (iii) (i) On non-lattice booms (whether horizontal or not horizontal).
- (iv) (ii) On lattice booms that are not horizontal.
- (v) (iii) On horizontal lattice booms where the fall distance is 15 feet or more.

- (2) While at a work station on any part of the equipment (including the boom, of any type), except when the employee is at or near draw-works (when the equipment is running), in the cab, or on the deck.

- (f) For assembly/disassembly work, the employer must provide and ensure the use of fall protection equipment for employees who are on a walking/working surface with an unprotected side or edge more than 15 feet above a lower level, except when the employee is at or near draw-works (when the equipment is running), in the cab, or on the deck.

(g) *Anchorage criteria.*

- (1) Sections 1926.502(d)(15) and 1926.502(e)(2) apply to equipment covered by this subpart only to the extent delineated in paragraph (g)(2) of this section.
- (2) *Anchorage for personal fall arrest and positioning device systems.*
  - (i) Personal fall arrest systems must be anchored to any apparently substantial part of the equipment unless a competent person, from a visual inspection, without an engineering analysis, would conclude that the criteria in § 1926.502(d)(15) would not be met.
  - (ii) Positioning device systems must be anchored to any apparently substantial part of the equipment unless a competent person, from a visual inspection, without an engineering analysis, would conclude that the criteria in § 1926.502(e)(2) would not be met.
  - (iii) Attachable anchor devices (portable anchor devices that are attached to the equipment) must meet the anchorage criteria in § 1926.502(d)(15) for personal fall arrest systems and § 1926.502(e)(2) for positioning device systems.
- (3) *Anchorage for fall restraint systems.* Fall restraint systems must be anchored to any part of the equipment that is capable of withstanding twice the maximum load that an employee may impose on it during reasonably anticipated conditions of use.

(h) *Tower cranes.*

- (1) For work other than erecting, climbing, and dismantling, the employer must provide and ensure the use of fall protection equipment for employees who are on a walking/ working surface with an unprotected side or edge more than 6 feet above a lower level, except when the employee is at or near draw-works (when the equipment is running), in the cab, or on the deck.
- (2) For erecting, climbing, and dismantling work, the employer must provide and ensure the use of fall protection equipment for employees who are on a walking/working surface with an unprotected side or edge more than 15 feet above a lower level.

(i) *[Reserved.]*

- (j) *Anchoring to the load line.* A personal fall arrest system is permitted to be anchored to the crane/ derrick's hook (or other part of the load line) where all of the following requirements are met:
- (1) A qualified person has determined that the set-up and rated capacity of the crane/derrick (including the hook, load line and rigging) meets

or exceeds the requirements in § 1926.502(d)(15).

- (2) The equipment operator must be at the work site and informed that the equipment is being used for this purpose.
  - (3) No load is suspended from the load line when the personal fall arrest system is anchored to the crane/ derrick's hook (or other part of the load line).
- (k) *Training.* The employer must train each employee who may be exposed to fall hazards while on, or hoisted by, equipment covered by this subpart on all of the following:
- (1) the requirements in this subpart that address fall protection.
  - (2) the applicable requirements in §§ 1926.500 and 1926.502.

## § 1926.1424 Work area control

(a) *Swing radius hazards.*

- (1) The requirements in paragraph (a)(2) of this section apply where there are accessible areas in which the equipment's rotating superstructure (whether permanently or temporarily mounted) poses a reasonably foreseeable risk of:
  - (i) Striking and injuring an employee; or
  - (ii) Pinching/crushing an employee against another part of the equipment or another object.
- (2) To prevent employees from entering these hazard areas, the employer must:
  - (i) Train each employee assigned to work on or near the equipment ("authorized personnel") in how to recognize struck-by and pinch/ crush hazard areas posed by the rotating superstructure.
  - (ii) Erect and maintain control lines, warning lines, railings or similar barriers to mark the boundaries of the hazard areas. *Exception:* When the employer can demonstrate that it is neither feasible to erect such barriers on the ground nor on the equipment, the hazard areas must be clearly marked by a combination of warning signs (such as "Danger—Swing/Crush Zone") and high visibility markings on the equipment that identify the hazard areas. In addition, the employer must train each employee to understand what these markings signify.
- (3) *Protecting employees in the hazard area.*
  - (i) Before an employee goes to a location in the hazard area that is out of view of the operator, the employee (or someone instructed by the employee) must ensure that the operator is informed that he/she is going to that location.

- (ii) Where the operator knows that an employee went to a location covered by paragraph (a) (1) of this section, the operator must not rotate the superstructure until the operator is informed in accordance with a pre-arranged system of communication that the employee is in a safe position.

- (b) Where any part of a crane/derrick is within the working radius of another crane/derrick, the controlling entity must institute a system to coordinate operations. If there is no controlling entity, the employer (if there is only one employer operating the multiple pieces of equipment), or employers, must institute such a system.

### § 1926.1425 Keeping clear of the load

- (a) Where available, hoisting routes that minimize the exposure of employees to hoisted loads must be used, to the extent consistent with public safety.
- (b) While the operator is not moving a suspended load, no employee must be within the fall zone, except for employees:
  - (1) Engaged in hooking, unhooking or guiding a load;
  - (2) Engaged in the initial attachment of the load to a component or structure; or
  - (3) Operating a concrete hopper or concrete bucket.
- (c) When employees are engaged in hooking, unhooking, or guiding the load, or in the initial connection of a load to a component or structure and are within the fall zone, all of the following criteria must be met:
  - (1) The materials being hoisted must be rigged to prevent unintentional displacement.
  - (2) Hooks with self-closing latches or their equivalent must be used. Exception: "J" hooks are permitted to be used for setting wooden trusses.
  - (3) The materials must be rigged by a qualified rigger.
- (d) *Receiving a load.* Only employees needed to receive a load are permitted to be within the fall zone when a load is being landed.
- (e) During a tilt-up or tilt-down operation:
  - (1) No employee must be directly under the load.
  - (2) Only employees essential to the operation are permitted in the fall zone (but not directly under the load). An employee is essential to the operation if the employee is conducting one of the following operations and the employer can demonstrate it is infeasible for the employee to perform that operation from outside the fall zone: (1) Physically guide the load; (2) closely monitor and give instructions regarding the load's movement; or (3) either detach it from

or initially attach it to another component or structure (such as, but not limited to, making an initial connection or installing bracing).

**Note:** Boom free fall is prohibited when an employee is in the fall zone of the boom or load, and load line free fall is prohibited when an employee is directly under the load; see § 1926.1426.

### § 1926.1425 Keeping clear of the load.

- (a) Where available, hoisting routes that minimize the exposure of employees to hoisted loads must be used, to the extent consistent with public safety.
- (b) While the operator is not moving a suspended load, no employee must be within the fall zone, except for employees:
  - (1) Engaged in hooking, unhooking or guiding a load;
  - (2) Engaged in the initial attachment of the load to a component or structure; or
  - (3) Operating a concrete hopper or concrete bucket.
- (c) When employees are engaged in hooking, unhooking, or guiding the load, or in the initial connection of a load to a component or structure and are within the fall zone, all of the following criteria must be met:
  - (1) The materials being hoisted must be rigged to prevent unintentional displacement.
  - (2) Hooks with self-closing latches or their equivalent must be used. Exception: "J" hooks are permitted to be used for setting wooden trusses.
  - (3) The materials must be rigged by a qualified rigger.
- (d) *Receiving a load.* Only employees needed to receive a load are permitted to be within the fall zone when a load is being landed.
- (e) During a tilt-up or tilt-down operation:
  - (1) No employee must be directly under the load.
  - (2) Only employees essential to the operation are permitted in the fall zone (but not directly under the load). An employee is essential to the operation if the employee is conducting one of the following operations and the employer can demonstrate it is infeasible for the employee to perform that operation from outside the fall zone: (1) Physically guide the load; (2) closely monitor and give instructions regarding the load's movement; or (3) either detach it from or initially attach it to another component or structure (such as, but not limited to, making an initial connection or installing bracing).

**Note:** Boom free fall is prohibited when an employee is in the fall zone of the boom or load, and load line free

fall is prohibited when an employee is directly under the load; see § 1926.1426.

### § 1926.1426 Free fall and controlled load lowering.

#### (a) *Boom free fall prohibitions.*

- (1) The use of equipment in which the boom is designed to free fall (live boom) is prohibited in each of the following circumstances:
  - (i) An employee is in the fall zone of the boom or load.
  - (ii) An employee is being hoisted.
  - (iii) The load or boom is directly over a power line, or over any part of the area extending the Table A of § 1926.1408 clearance distance to each side of the power line; or any part of the area extending the Table A clearance distance to each side of the power line is within the radius of vertical travel of the boom or the load.
  - (iv) The load is over a shaft, except where there are no employees in the shaft.
  - (v) The load is over a cofferdam, except where there are no employees in the fall zone of the boom or the load.
  - (vi) Lifting operations are taking place in a refinery or tank farm.
- (2) The use of equipment in which the boom is designed to free fall (live boom) is permitted only where none of the circumstances listed in paragraph (a)(1) of this section are present and:
  - (i) The equipment was manufactured prior to October 31, 1984; or
  - (ii) The equipment is a floating crane/ derrick or a land crane/derrick on a vessel/flotation device.

(b) *Preventing boom free fall.* Where the use of equipment with a boom that is designed to free fall (live boom) is prohibited, the boom hoist must have a secondary mechanism or device designed to prevent the boom from falling in the event the primary system used to hold or regulate the boom hoist fails, as follows:

- (1) Friction drums must have:
  - (i) A friction clutch and, in addition, a braking device, to allow for controlled boom lowering.
  - (ii) A secondary braking or locking device, which is manually or automatically engaged, to back-up the primary brake while the boom is held (such as a secondary friction brake or a ratchet and pawl device).
- (2) Hydraulic drums must have an integrally mounted holding device or internal static brake to prevent boom hoist movement in the event of hydraulic failure.

(3) Neither clutches nor hydraulic motors must be considered brake or locking devices for purposes of this subpart.

(4) Hydraulic boom cylinders must have an integrally mounted holding device.

(c) *Preventing uncontrolled retraction.* Hydraulic telescoping booms must have an integrally mounted holding device to prevent the boom from retracting in the event of hydraulic failure.

(d) *Load line free fall.* In each of the following circumstances, controlled load lowering is required and free fall of the load line hoist is prohibited:

(1) An employee is directly under the load.

(2) An employee is being hoisted.

(3) The load is directly over a power line, or over any part of the area extending the Table A of § 1926.1408 clearance distance to each side of the power line; or any part of the area extending the Table A of § 1926.1408 clearance distance to each side of the power line is within the radius of vertical travel of the load.

(4) The load is over a shaft.

(5) The load is over a cofferdam, except where there are no employees in the fall zone of the load.

### § 1926.1427 Operator qualification and certification.

(a) The employer must ensure that, prior to operating any equipment covered under subpart CC, the person is operating the equipment during a training period in accordance with paragraph (f) of this section, or the operator is qualified or certified to operate the equipment in accordance with the following:

(1) When a non-military government entity issues operator licenses for equipment covered under subpart CC, and that government licensing program meets the requirements of paragraphs (e)(2) and (j) of this section, the equipment operator must either be:

(i) Licensed by that government entity for operation of equipment within that entity's jurisdiction; or

(ii) qualified in compliance with paragraph (d) of this section.

(2) Where paragraph (a)(1) of this section is not applicable, the certification or qualification must comply with one of the options in paragraphs (b) through (d) of this section.

(3) *Exceptions:* Operator qualification or certification under this section is not required for operators of derricks (*see* § 1926.1436), side-boom cranes (*see* § 1926.1440), or equipment with a maximum manufacturer-rated hoisting/

lifting capacity of 2,000 pounds or less (*see* § 1926.1441).

- (4) Whenever operator qualification or certification is required under § 1926.1427, the employer must provide the qualification or certification at no cost to operators who are employed by the employer on November 8, 2010.
- (b) *Option (1): Certification by an accredited crane operator testing organization.*
  - (1) For a testing organization to be considered accredited to certify operators under this subpart, it must:
    - (i) Be accredited by a nationally recognized accrediting agency based on that agency's determination that industry recognized criteria for written testing materials, practical examinations, test administration, grading, facilities/equipment and personnel have been met.
    - (ii) Administer written and practical tests that:
      - (A) Assess the operator applicant regarding, at a minimum, the knowledge and skills listed in paragraphs (j)(1) and (2) of this section.
      - (B) Provide different levels of certification based on equipment capacity and type.
    - (iii) Have procedures for operators to re-apply and be re-tested in the event an operator applicant fails a test or is decertified.
    - (iv) Have testing procedures for re-certification designed to ensure that the operator continues to meet the technical knowledge and skills requirements in paragraphs (j)(1) and (2) of this section.
    - (v) Have its accreditation reviewed by the nationally recognized accrediting agency at least every three years.
  - (2) An operator will be deemed qualified to operate a particular piece of equipment if the operator is certified under paragraph (b) of this section for that type and capacity of equipment or for higher-capacity equipment of that type. If no accredited testing agency offers certification examinations for a particular type and/or capacity of equipment, an operator will be deemed qualified to operate that equipment if the operator has been certified for the type/capacity that is most similar to that equipment and for which a certification examination is available. The operator's certificate must state the type/capacity of equipment for which the operator is certified.
  - (3) A certification issued under this option is portable and meets the requirements of paragraph (a)(2) of this section.
- (4) A certification issued under this paragraph is valid for 5 years.
- (c) *Option (2): Qualification by an audited employer program.* The employer's qualification of its employee must meet the following requirements:
  - (1) The written and practical tests must be either:
    - (i) Developed by an accredited crane operator testing organization (*see* paragraph (b) of this section); or
    - (ii) Approved by an auditor in accordance with the following requirements:
      - (A) The auditor is certified to evaluate such tests by an accredited crane operator testing organization (*see* paragraph (b) of this section).
      - (B) The auditor is not an employee of the employer.
      - (C) The approval must be based on the auditor's determination that the written and practical tests meet nationally recognized test development criteria and are valid and reliable in assessing the operator applicants regarding, at a minimum, the knowledge and skills listed in paragraphs (j)(1) and (2) of this section.
      - (D) The audit must be conducted in accordance with nationally recognized auditing standards.
  - (2) *Administration of tests.*
    - (i) The written and practical tests must be administered under circumstances approved by the auditor as meeting nationally recognized test administration standards.
    - (ii) The auditor must be certified to evaluate the administration of the written and practical tests by an accredited crane operator testing organization (*see* paragraph (b) of this section).
    - (iii) The auditor must not be an employee of the employer.
    - (iv) The audit must be conducted in accordance with nationally recognized auditing standards.
  - (3) The employer program must be audited within 3 months of the beginning of the program and at least every 3 years thereafter.
  - (4) The employer program must have testing procedures for re-qualification designed to ensure that the operator continues to meet the technical knowledge and skills requirements in paragraphs (j)(1) and (2) of this section. The re-qualification procedures must be audited in accordance with paragraphs (c)(1) and (2) of this section.

- (5) *Deficiencies.* If the auditor determines that there is a significant deficiency (“deficiency”) in the program, the employer must ensure that:
- (i) No operator is qualified until the auditor confirms that the deficiency has been corrected.
  - (ii) The program is audited again within 180 days of the confirmation that the deficiency was corrected.
  - (iii) The auditor files a documented report of the deficiency to the appropriate Regional Office of the Occupational Safety and Health Administration within 15 days of the auditor’s determination that there is a deficiency.
  - (iv) Records of the audits of the employer’s program are maintained by the auditor for three years and are made available by the auditor to the Secretary of Labor or the Secretary’s designated representative upon request.
- (6) A qualification under this paragraph is:
- (i) Not portable. Such a qualification meets the requirements of paragraph (a) of this section only where the operator is employed by (and operating the equipment for) the employer that issued the qualification.
  - (ii) Valid for 5 years.
- (d) *Option (3): Qualification by the U.S. military.*
- (1) For purposes of this section, an operator who is an employee of the U.S. military is considered qualified if he/ she has a current operator qualification issued by the U.S. military for operation of the equipment. An employee of the U.S. military is a Federal employee of the Department of Defense or Armed Forces and does not include employees of private contractors.
  - (2) A qualification under this paragraph is:
    - (i) Not portable. Such a qualification meets the requirements of paragraph (a) of this section only where the operator is employed by (and operating the equipment for) the employer that issued the qualification.
    - (ii) Valid for the period of time stipulated by the issuing entity.
- (e) *Option (4): Licensing by a government entity.*
- (1) For purposes of this section, a government licensing department/office that issues operator licenses for operating equipment covered by this standard is considered a government accredited crane operator testing organization if the criteria in paragraph (e)(2) of this section are met.
  - (2) *Licensing criteria.*
    - (i) The requirements for obtaining the license include an assessment, by written and practical tests, of the operator applicant regarding, at a minimum, the knowledge and skills listed in paragraphs (j)(1) and (2) of this section.
      - (ii) The testing meets industry recognized criteria for written testing materials, practical examinations, test administration, grading, facilities/ equipment and personnel.
      - (iii) The government authority that oversees the licensing department/ office, has determined that the requirements in paragraphs (e)(2)(i) and (ii) of this section have been met.
      - (iv) The licensing department/office has testing procedures for re-licensing designed to ensure that the operator continues to meet the technical knowledge and skills requirements in paragraphs (j)(1) and (2) of this section.
  - (3) A license issued by a government accredited crane operator testing organization that meets the requirements of this option:
    - (i) Meets the operator qualification requirements of this section for operation of equipment only within the jurisdiction of the government entity.
    - (ii) Is valid for the period of time stipulated by the licensing department/ office, but no longer than 5 years.
- (f) *Pre-qualification/certification training period.* An employee who is not qualified or certified under this section is permitted to operate equipment only as an operator-in-training and only where the requirements of this paragraph are met.
- (1) The employer must provide each operator-in-training with sufficient training prior to operating the equipment to enable the operator-in-training to operate the equipment safely under limitations established by this section (including continuous monitoring) and any additional limitations established by the employer.
  - (2) The tasks performed by the operator-in-training while operating the equipment must be within the operator-in-training’s ability.
  - (3) *Trainer.* While operating the equipment, the operator-in-training must be continuously monitored by an individual (“operator’s trainer”) who meets all of the following requirements:
    - (i) The operator’s trainer is an employee or agent of the operator-in-training’s employer.
    - (ii) The operator’s trainer is either a certified operator under this section, or has passed the written portion of a certification test under one of the options in paragraphs (b) through (e) of this section, and is familiar with the proper use of the equipment’s controls.
    - (iii) While monitoring the operator-in-training, the operator’s trainer performs no tasks that detract from the trainer’s ability to monitor the operator-in-training.

- (iv) For equipment other than tower cranes:  
The operator's trainer and the operator-in-training must be in direct line of sight of each other. In addition, they must communicate verbally or by hand signals. For tower cranes:  
The operator's trainer and the operator-in-training must be in direct communication with each other.
- (4) *Continuous monitoring.* The operator-in-training must be monitored by the operator's trainer at all times, except for short breaks where all of the following are met:
  - (i) The break lasts no longer than 15 minutes and there is no more than one break per hour.
  - (ii) Immediately prior to the break the operator's trainer informs the operator-in-training of the specific tasks that the operator-in-training is to perform and limitations to which he/she must adhere during the operator trainer's break.
  - (iii) The specific tasks that the operator-in-training will perform during the operator trainer's break are within the operator-in-training's abilities.
- (5) The operator-in-training must not operate the equipment in any of the following circumstances unless the exception stated in paragraph (f)(5)(v) of this section is applicable:
  - (i) If any part of the equipment, load line or load (including rigging and lifting accessories), if operated up to the equipment's maximum working radius in the work zone (*see* § 1926.1408(a)(1)), could get within 20 feet of a power line that is up to 350 kV, or within 50 feet of a power line that is over 350 kV.
  - (ii) If the equipment is used to hoist personnel.
  - (iii) In multiple-equipment lifts.
  - (iv) If the equipment is used over a shaft, cofferdam, or in a tank farm.
  - (v) In multiple-lift rigging operations, except where the operator's trainer determines that the operator-in-training skills are sufficient for this high-skill work.
- (g) Under this section, a testing entity is permitted to provide training as well as testing services as long as the criteria of the applicable accrediting agency (in the option selected) for an organization providing both services are met.
- (h) *Language and Literacy Requirements.*
  - (1) Tests under this section may be administered verbally, with answers given verbally, where the operator candidate:
    - (i) Passes a written demonstration of literacy relevant to the work.
    - (ii) Demonstrates the ability to use the type of written manufacturer procedures applicable to the class/type of equipment for which the candidate is seeking certification.
  - (2) Tests under this section may be administered in any language the operator candidate understands, and the operator's certificate must note the language in which the test was given. The operator is qualified under paragraph (b)(2) of this section to operate equipment that is furnished with materials required by this subpart that are written in the language of the certification. The operator may only operate equipment furnished with such materials.
    - (i) *[Reserved.]*
    - (j) *Certification criteria.* Qualifications and certifications must be based, at a minimum, on the following:
      - (1) A determination through a written test that:
        - (i) The individual knows the information necessary for safe operation of the specific type of equipment the individual will operate, including all of the following:
          - (A) The controls and operational/ performance characteristics.
          - (B) Use of, and the ability to calculate (manually or with a calculator), load/ capacity information on a variety of configurations of the equipment.
          - (C) Procedures for preventing and responding to power line contact.
          - (D) Technical knowledge similar to the subject matter criteria listed in Appendix C of this subpart applicable to the specific type of equipment the individual will operate. Use of the Appendix C criteria meets the requirements of this provision.
          - (E) Technical knowledge applicable to:
            - (1) The suitability of the supporting ground and surface to handle expected loads.
            - (2) Site hazards.
            - (3) Site access.
          - (F) This subpart, including applicable incorporated materials.
        - (ii) The individual is able to read and locate relevant information in the equipment manual and other materials containing information referred to in paragraph (j)(1)(i) of this section.
      - (2) A determination through a practical test that the individual has the skills necessary for safe operation of the equipment, including the following:
        - (i) Ability to recognize, from visual and auditory observation, the items listed in § 1926.1412(d) (shift inspection).

- (ii) Operational and maneuvering skills.
- (iii) Application of load chart information.
- (iv) Application of safe shut-down and securing procedures.

(k) *Phase-in.*

- (1) The provisions of this section are applicable November 8, 2010, except for paragraphs (a)(2) and (f) which are applicable November 10, 2014.
- (2) When § 1926.1427(a)(1) is not applicable, all of the requirements in paragraphs (k)(2)(i) and (ii) of this section apply until November 10, 2014:
  - (i) The employer must ensure that operators of equipment covered by this standard are competent to operate the equipment safely.
  - (ii) Where an employee assigned to operate machinery does not have the required knowledge or ability to operate the equipment safely, the employer must train that employee prior to operating the equipment. The employer must ensure that each operator is evaluated to confirm that he/she understands the information provided in the training.

**§ 1926.1428 Signal person qualifications.**

- (a) The employer of the signal person must ensure that each signal person meets the Qualification Requirements (paragraph (c) of this section) prior to giving any signals. This requirement must be met by using either Option (1) or Option (2) of this section.
  - (1) *Option (1)—Third party qualified evaluator.* The signal person has documentation from a third party qualified evaluator (see Qualified Evaluator (third party), § 1926.1401 for definition) showing that the signal person meets the Qualification Requirements (see paragraph (c) of this section).
  - (2) *Option (2)—Employer's qualified evaluator.* The employer's qualified (see Qualified Evaluator (not a third party), § 1926.1401 for definition) evaluator assesses the individual and determines that the individual meets the Qualification Requirements (see paragraph (c) of this section) and provides documentation of that determination. An assessment by an employer's qualified evaluator under this option is not portable—other employers are not permitted to use it to meet the requirements of this section.
  - (3) The employer must make the documentation for whichever option is used available at the site while the signal person is employed by the employer. The documentation must specify each type of signaling (*e.g.* hand signals, radio signals, *etc.*) for which the signal person meets the requirements of paragraph (c) of this section.

- (b) If subsequent actions by the signal person indicate that the individual does not meet the Qualification Requirements (see paragraph (c) of this section), the employer must not allow the individual to continue working as a signal person until re-training is provided and a re-assessment is made in accordance with paragraph (a) of this section that confirms that the individual meets the Qualification Requirements.

(c) *Qualification Requirements.* Each signal person must:

- (1) Know and understand the type of signals used. If hand signals are used, the signal person must know and understand the Standard Method for hand signals.
- (2) Be competent in the application of the type of signals used.
- (3) Have a basic understanding of equipment operation and limitations, including the crane dynamics involved in swinging and stopping loads and boom deflection from hoisting loads.
- (4) Know and understand the relevant requirements of § 1926.1419 through § 1926.1422 and § 1926.1428.
- (5) Demonstrate that he/she meets the requirements in paragraphs (c)(1) through (4) of this section through an oral or written test, and through a practical test.

**§ 1926.1429 Qualifications of maintenance & repair employees.**

- (a) Maintenance, inspection and repair personnel are permitted to operate the equipment only where all of the following requirements are met:
  - (1) The operation is limited to those functions necessary to perform maintenance, inspect the equipment, or verify its performance.
  - (2) The personnel either:
    - (i) Operate the equipment under the direct supervision of an operator who meets the requirements of § 1926.1427 (Operator qualification and certification); or
    - (ii) Are familiar with the operation, limitations, characteristics and hazards associated with the type of equipment.
- (b) Maintenance and repair personnel must meet the definition of a qualified person with respect to the equipment and maintenance/repair tasks performed.



## § 1926.1430 Training.

The employer must provide training as follows:

- (a) *Overhead powerlines.* The employer must train each employee specified in § 1926.1408(g) and § 1926.1410(m) in the topics listed in § 1926.1408(g).
- (b) *Signal persons.* The employer must train each employee who will be assigned to work as a signal persons who does not meet the requirements of § 1926.1428(c) in the areas addressed in that paragraph.
- (c) *Operators.*
  - (1) *Operators-in-Training for equipment where certification or qualification is required by this subpart.* The employer must train each operator-in-training in the areas addressed in § 1926.1427(j). The employer must provide re-training if the operator-in-training does not pass a qualification or certification test.
  - (2) *Transitional Period.* During the four-year phase-in period for operator certification or qualification, as provided in § 1926.1427(k), employers must train each operator who has not yet been certified or qualified in the areas addressed in § 1926.1427(j).
  - (3) *Operators excepted from the requirements of § 1926.1427.* The employer must train each operator excepted under § 1926.1427(a) from the requirements of § 1926.1427 on the safe operation of the equipment the operator will be using.
  - (4) The employer must train each operator of the equipment covered by this subpart in the following practices:
    - (i) On friction equipment, whenever moving a boom off a support, first raise the boom a short distance (sufficient to take the load of the boom) to determine if the boom hoist brake needs to be adjusted. On other types of equipment with a boom, the same practice is applicable, except that typically there is no means of adjusting the brake; if the brake does not hold, a repair is necessary. See § 1926.1417(f) and (j) for additional requirements.
    - (ii) Where available, the manufacturer's emergency procedures for halting unintended equipment movement.
- (d) *Competent persons and qualified persons.* The employer must train each competent person and each qualified person regarding the requirements of this subpart applicable to their respective roles.
- (e) *Crush/pinch points.* The employer must train each employee who works with the equipment to keep clear of holes, and crush/pinch points and the hazards addressed in § 1926.1424 (Work area control).

- (f) *Tag-out.* The employer must train each operator and each additional employee authorized to start/energize equipment or operate equipment controls (such as maintenance and repair employees), in the tag-out and start-up procedures in §§ 1926.1417(f) and (g).
- (g) *Training administration.*
  - (1) The employer must evaluate each employee required to be trained under this subpart to confirm that the employee understands the information provided in the training.
  - (2) The employer must provide refresher training in relevant topics for each employee when, based on the conduct of the employee or an evaluation of the employee's knowledge, there is an indication that retraining is necessary.
  - (3) Whenever training is required under subpart CC, the employer must provide the training at no cost to the employee.

## § 1926.1431 Hoisting personnel

The requirements of this section are supplemental to the other requirements in this subpart and apply when one or more employees are hoisted.

- (a) The use of equipment to hoist employees is prohibited except where the employer demonstrates that the erection, use, and dismantling of conventional means of reaching the work area, such as a personnel hoist, ladder, stairway, aerial lift, elevating work platform, or scaffold, would be more hazardous, or is not possible because of the project's structural design or worksite conditions. This paragraph does not apply to work covered by subpart R (Steel Erection) of this part.
- (b) *Use of personnel platform.*
  - (1) When using equipment to hoist employees, the employees must be in a personnel platform that meets the requirements of paragraph (e) of this section.
  - (2) *Exceptions:* A personnel platform is not required for hoisting employees:
    - (i) Into and out of drill shafts that are up to and including 8 feet in diameter (see paragraph (o) of this section for requirements for hoisting these employees).
    - (ii) In pile driving operations (see paragraph (p) of this section for requirements for hoisting these employees).
    - (iii) Solely for transfer to or from a marine worksite in a marine-hoisted personnel transfer device (see paragraph (r) of this section for requirements for hoisting these employees).
    - (iv) In storage-tank (steel or concrete), shaft and chimney operations (see paragraph (s) of this

section for requirements for hoisting these employees).

(c) *Equipment set-up.*

- (1) The equipment must be uniformly level, within one percent of level grade, and located on footing that a qualified person has determined to be sufficiently firm and stable.
- (2) Equipment with outriggers or stabilizers must have them all extended and locked. The amount of extension must be the same for all outriggers and stabilizers and in accordance with manufacturer procedures and load charts.

(d) *Equipment criteria.*

- (1) *Capacity: Use of suspended personnel platforms.* The total load (with the platform loaded, including the hook, load line and rigging) must not exceed 50 percent of the rated capacity for the radius and configuration of the equipment, except during proof testing.
- (2) *Capacity: Use of boom-attached personnel platforms.* The total weight of the loaded personnel platform must not exceed 50 percent of the rated capacity for the radius and configuration of the equipment (except during proof testing).
- (3) *Capacity: Hoisting personnel without a personnel platform.* When hoisting personnel without a personnel platform pursuant to paragraph (b) (2) of this section, the total load (including the hook, load line, rigging and any other equipment that imposes a load) must not exceed 50 percent of the rated capacity for the radius and configuration of the equipment, except during proof testing.
- (4) When the occupied personnel platform is in a stationary working position, the load and boom hoist brakes, swing brakes, and operator actuated secondary braking and locking features (such as pawls or dogs) or automatic secondary brakes must be engaged.

(5) *Devices.*

- (i) Equipment (except for derricks and articulating cranes) with a variable angle boom must be equipped with all of the following:
  - (A) A boom angle indicator, readily visible to the operator, and
  - (B) A boom hoist limiting device.
- (ii) Articulating cranes must be equipped with a properly functioning automatic overload protection device.
- (iii) Equipment with a luffing jib must be equipped with:
  - (A) A jib angle indicator, readily visible to the operator, and
  - (B) A jib hoist limiting device.

(iv) Equipment with telescoping booms must be equipped with a device to indicate the boom's extended length clearly to the operator, or must have measuring marks on the boom.

(v) *Anti two-block.* A device which automatically prevents damage and load failure from contact between the load block, overhaul ball, or similar component, and the boom tip (or fixed upper block or similar component) must be used. The device(s) must prevent such damage/failure at all points where two-blocking could occur. Exception: This device is not required when hoisting personnel in pile driving operations. Instead, paragraph (p)(2) of this section specifies how to prevent two-blocking during such operations.

(vi) *Controlled load lowering.* The load line hoist drum must have a system, other than the load line hoist brake, which regulates the lowering rate of speed of the hoist mechanism. This system or device must be used when hoisting personnel.

**Note:** Free fall of the load line hoist is prohibited (see § 1926.1426(d)); the use of equipment in which the boom hoist mechanism can free fall is also prohibited (see § 1926.1426(a)(1)).

(vii) *Proper operation required.* Personnel hoisting operations must not begin unless the devices listed in this section are in proper working order. If a device stops working properly during such operations, the operator must safely stop operations. Personnel hoisting operations must not resume until the device is again working properly. Alternative measures are not permitted. (See § 1926.1417 for tag-out and related requirements.)

(6) Direct attachment of a personnel platform to a luffing jib is prohibited.

(e) *Personnel platform criteria.*

- (1) A qualified person familiar with structural design must design the personnel platform and attachment/ suspension system used for hoisting personnel.
- (2) The system used to connect the personnel platform to the equipment must allow the platform to remain within 10 degrees of level, regardless of boom angle.
- (3) The suspension system must be designed to minimize tipping of the platform due to movement of employees occupying the platform.
- (4) The personnel platform itself (excluding the guardrail system and personal fall arrest system anchorages), must be capable of supporting, without failure, its own weight and at least five times the maximum intended load.

- (5) All welding of the personnel platform and its components must be performed by a certified welder familiar with the weld grades, types and material specified in the platform design.
- (6) The personnel platform must be equipped with a guardrail system which meets the requirements of subpart M of this part, and must be enclosed at least from the toeboard to mid-rail with either solid construction material or expanded metal having openings no greater than 1/2 inch (1.27 cm). Points to which personal fall arrest systems are attached must meet the anchorage requirements in subpart M of this part.
- (7) A grab rail must be installed inside the entire perimeter of the personnel platform except for access gates/doors.
- (8) *Access gates/doors.* If installed, access gates/doors of all types (including swinging, sliding, folding, or other types) must:
- (i) Not swing outward. If due to the size of the personnel platform, such as a 1-person platform, it is infeasible for the door to swing inward and allow safe entry for the platform occupant, then the access gate/door may swing outward.
  - (ii) Be equipped with a device that prevents accidental opening.
- (9) Headroom must be sufficient to allow employees to stand upright in the platform.
- (10) In addition to the use of hard hats, employees must be protected by overhead protection on the personnel platform when employees are exposed to falling objects. The platform overhead protection must not obscure the view of the operator or platform occupants (such as wire mesh that has up to 1/2 inch openings), unless full protection is necessary.
- (11) All edges exposed to employee contact must be smooth enough to prevent injury.
- (12) The weight of the platform and its rated capacity must be conspicuously posted on the platform with a plate or other permanent marking.
- (f) *Personnel platform loading.*
- (1) The personnel platform must not be loaded in excess of its rated capacity.
  - (2) *Use.*
    - (i) Personnel platforms must be used only for employees, their tools, and the materials necessary to do their work. Platforms must not be used to hoist materials or tools when not hoisting personnel.
    - (ii) *Exception:* Materials and tools to be used during the lift, if secured and distributed in accordance with paragraph (f)(3) of this section may be in the platform for trial lifts.
- (3) Materials and tools must be:
- (i) Secured to prevent displacement.
  - (ii) Evenly distributed within the confines of the platform while it is suspended.
- (4) The number of employees occupying the personnel platform must not exceed the maximum number the platform was designed to hold or the number required to perform the work, whichever is less.
- (g) *Attachment and rigging.*
- (1) *Hooks and other detachable devices.*
    - (i) Hooks used in the connection between the hoist line and the personnel platform (including hooks on overhaul ball assemblies, lower load blocks, bridle legs, or other attachment assemblies or components) must be:
      - (A) Of a type that can be closed and locked, eliminating the throat opening.
      - (B) Closed and locked when attached.
    - (ii) Shackles used in place of hooks must be of the alloy anchor type, with either:
      - (A) A bolt, nut and retaining pin, in place; or
      - (B) Of the screw type, with the screw pin secured from accidental removal.
    - (iii) Where other detachable devices are used, they must be of the type that can be closed and locked to the same extent as the devices addressed in paragraphs (g)(1)(i) and (ii) of this section. Such devices must be closed and locked when attached.
  - (2) *Rope bridle.* When a rope bridle is used to suspend the personnel platform, each bridle leg must be connected to a master link or shackle (see paragraph (g)(1) of this section) in a manner that ensures that the load is evenly divided among the bridle legs.
  - (3) Rigging hardware (including wire rope, shackles, rings, master links, and other rigging hardware) and hooks must be capable of supporting, without failure, at least five times the maximum intended load applied or transmitted to that component. Where rotation resistant rope is used, the slings must be capable of supporting without failure at least ten times the maximum intended load.
  - (4) Eyes in wire rope slings must be fabricated with thimbles.
  - (5) Bridles and associated rigging for suspending the personnel platform must be used only for the platform and the necessary employees, their tools and materials necessary to do their work. The bridles and associated rigging must not have

been used for any purpose other than hoisting personnel.

(h) *Trial lift and inspection.*

- (1) A trial lift with the unoccupied personnel platform loaded at least to the anticipated liftweight must be made from ground level, or any other location where employees will enter the platform, to each location at which the platform is to be hoisted and positioned. Where there is more than one location to be reached from a single set-up position, either individual trial lifts for each location, or a single trial lift, in which the platform is moved sequentially to each location, must be performed; the method selected must be the same as the method that will be used to hoist the personnel.
- (2) The trial lift must be performed immediately prior to each shift in which personnel will be hoisted. In addition, the trial lift must be repeated prior to hoisting employees in each of the following circumstances:
  - (i) The equipment is moved and set up in a new location or returned to a previously used location.
  - (ii) The lift route is changed, unless the competent person determines that the new route presents no new factors affecting safety.
- (3) The competent person must determine that:
  - (i) Safety devices and operational aids required by this section are activated and functioning properly. Other safety devices and operational aids must meet the requirements of § 1926.1415 and § 1926.1416.
  - (ii) Nothing interferes with the equipment or the personnel platform in the course of the trial lift.
  - (iii) The lift will not exceed 50 percent of the equipment's rated capacity at any time during the lift.
  - (iv) The load radius to be used during the lift has been accurately determined.
- (4) Immediately after the trial lift, the competent person must:
  - (i) Conduct a visual inspection of the equipment, base support or ground, and personnel platform, to determine whether the trial lift has exposed any defect or problem or produced any adverse effect.
  - (ii) Confirm that, upon the completion of the trial lift process, the test weight has been removed.
- (5) Immediately prior to each lift:
  - (i) The platform must be hoisted a few inches with the personnel and materials/tools on board and inspected by a competent person

to ensure that it is secure and properly balanced.

- (ii) The following conditions must be determined by a competent person to exist before the lift of personnel proceeds:

- (A) Hoist ropes must be free of deficiencies in accordance with § 1926.1413(a).
- (B) Multiple part lines must not be twisted around each other.
- (C) The primary attachment must be centered over the platform.
- (D) If the load rope is slack, the hoisting system must be inspected to ensure that all ropes are properly seated on drums and in sheaves.

- (6) Any condition found during the trial lift and subsequent inspection(s) that fails to meet a requirement of this standard or otherwise creates a safety hazard must be corrected before hoisting personnel. (See § 1926.1417 for tag-out and related requirements.)

(i) *[Reserved.]*

(j) *Proof testing.*

- (1) At each jobsite, prior to hoisting employees on the personnel platform, and after any repair or modification, the platform and rigging must be proof tested to 125 percent of the platform's rated capacity. The proof test may be done concurrently with the trial lift.
- (2) The platform must be lowered by controlled load lowering, braked, and held in a suspended position for a minimum of five minutes with the test load evenly distributed on the platform.
- (3) After proof testing, a competent person must inspect the platform and rigging to determine if the test has been passed. If any deficiencies are found that pose a safety hazard, the platform and rigging must not be used to hoist personnel unless the deficiencies are corrected, the test is repeated, and a competent person determines that the test has been passed. (See § 1926.1417 for tag-out and related requirements.)
- (4) Personnel hoisting must not be conducted until the competent person determines that the platform and rigging have successfully passed the proof test.

(k) *Work practices.*

- (1) Hoisting of the personnel platform must be performed in a slow, controlled, cautious manner, with no sudden movements of the equipment or the platform.
- (2) Platform occupants must:
  - (i) Keep all parts of the body inside the platform during raising, lowering, and horizontal

movement. This provision does not apply to an occupant of the platform when necessary to position the platform or while performing the duties of a signal person.

- (ii) Not stand, sit on, or work from the top or intermediate rail or toeboard, or use any other means/device to raise their working height.
  - (iii) Not pull the platform out of plumb in relation to the hoisting equipment.
- (3) Before employees exit or enter a hoisted personnel platform that is not landed, the platform must be secured to the structure where the work is to be performed, unless the employer can demonstrate that securing to the structure would create a greater hazard.
- (4) If the platform is tied to the structure, the operator must not move the platform until the operator receives confirmation that it is freely suspended.
- (5) Tag lines must be used when necessary to control the platform.
- (6) *Platforms without controls.* Where the platform is not equipped with controls, the equipment operator must remain at the equipment controls, on site, and in view of the equipment, at all times while the platform is occupied.
- (7) *Platforms with controls.* Where the platform is equipped with controls, all of the following must be met at all times while the platform is occupied:
- (i) The occupant using the controls in the platform must be a qualified person with respect to their use, including the safe limitations of the equipment and hazards associated with its operation.
  - (ii) The equipment operator must be at a set of equipment controls that include boom and swing functions of the equipment, and must be on site and in view of the equipment.
  - (iii) The platform operating manual must be in the platform or on the equipment.
- (8) *Environmental conditions.*
- (i) *Wind.* When wind speed (sustained or gusts) exceeds 20 mph at the personnel platform, a qualified person must determine if, in light of the wind conditions, it is not safe to lift personnel. If it is not, the lifting operation must not begin (or, if already in progress, must be terminated).
  - (ii) *Other weather and environmental conditions.* A qualified person must determine if, in light of indications of dangerous weather conditions, or other impending or existing danger, it is not safe to lift personnel. If it is not, the lifting operation must not begin (or, if already in progress, must be terminated).
- (9) Employees being hoisted must remain in direct communication with the signal person (where used), or the operator.
- (10) *Fall protection.*
- (i) Except over water, employees occupying the personnel platform must be provided and use a personal fall arrest system. The system must be attached to a structural member within the personnel platform. When working over or near water, the requirements of § 1926.106 apply.
  - (ii) The fall arrest system, including the attachment point (anchorage) used to comply with paragraph (i) of this section, must meet the requirements in § 1926.502.
- (11) *Other load lines.*
- (i) No lifts must be made on any other of the equipment's load lines while personnel are being hoisted, except in pile driving operations.
  - (ii) *Factory-produced boom-mounted personnel platforms that incorporate a winch as original equipment.* Loads are permitted to be hoisted by such a winch while employees occupy the personnel platform only where the load on the winch line does not exceed 500 pounds and does not exceed the rated capacity of the winch and platform.
- (12) *Traveling—equipment other than derricks.*
- (i) Hoisting of employees while the equipment is traveling is prohibited, except for:
    - (A) Equipment that travels on fixed rails; or
    - (B) Where the employer demonstrates that there is no less hazardous way to perform the work.
    - (C) This exception does not apply to rubber-tired equipment.
  - (ii) Where employees are hoisted while the equipment is traveling, all of the following criteria must be met:
    - (A) Equipment travel must be restricted to a fixed track or runway.
    - (B) Where a runway is used, it must be a firm, level surface designed, prepared and designated as a path of travel for the weight and configuration of the equipment being used to lift and travel with the personnel platform. An existing surface may be used as long as it meets these criteria.
    - (C) Equipment travel must be limited to boom length.

- (D) The boom must be parallel to the direction of travel, except where it is safer to do otherwise.
- (E) A complete trial run must be performed to test the route of travel before employees are allowed to occupy the platform. This trial run can be performed at the same time as the trial lift required by paragraph (h) of this section which tests the lift route.

(13) *Traveling—derricks.* Derricks are prohibited from traveling while personnel are hoisted.

(l) *[Reserved.]*

(m) *Pre-lift meeting.* A pre-lift meeting must be:

- (1) Held to review the applicable requirements of this section and the procedures that will be followed.
- (2) Attended by the equipment operator, signal person (if used for the lift), employees to be hoisted, and the person responsible for the task to be performed.
- (3) Held prior to the trial lift at each new work location, and must be repeated for any employees newly assigned to the operation.

(n) *Hoisting personnel near power lines.* Hoisting personnel within 20 feet of a power line that is up to 350 kV, and hoisting personnel within 50 feet of a power line that is over 350 kV, is prohibited, except for work covered by subpart V of this part (Power Transmission and Distribution).

(o) *Hoisting personnel in drill shafts.* When hoisting employees into and out of drill shafts that are up to and including 8 feet in diameter, all of the following requirements must be met:

- (1) The employee must be in either a personnel platform or on a boatswain's chair.
- (2) If using a personnel platform, paragraphs (a) through (n) of this section apply.
- (3) If using a boatswain's chair:
  - (i) The following paragraphs of this section apply: (a), (c), (d)(1), (d)(3), (d)(4), (e)(1), (e)(2), (e)(3), (f)(1), (f)(2)(i), (f)(3)(i), (g), (h), (k)(1), (k)(6), (k)(8), (k)(9), (k)(11)(i), (m), (n). Where the terms "personnel platform" or "platform" are used in these paragraphs, substitute them with "boatswain's chair."
  - (ii) A signal person must be stationed at the shaft opening.
  - (iii) The employee must be hoisted in a slow, controlled descent and ascent.
  - (iv) The employee must use personal fall protection equipment, including a full body harness, attached independent of the crane/derrick.

- (v) The fall protection equipment must meet the applicable requirements in § 1926.502.
- (vi) The boatswain's chair itself (excluding the personal fall arrest system anchorages), must be capable of supporting, without failure, its own weight and at least five times the maximum intended load.
- (vii) No more than one person must be hoisted at a time.

(p) *Hoisting personnel for pile driving operations.* When hoisting an employee in pile driving operations, the following requirements must be met:

- (1) The employee must be in a personnel platform or boatswain's chair.
- (2) *For lattice boom cranes:* Clearly mark the cable (so that it can easily be seen by the operator) at a point that will give the operator sufficient time to stop the hoist to prevent two-blocking, or use a spotter who is in direct communication with the operator to inform the operator when this point is reached.

*For telescopic boom cranes:* Clearly mark the cable (so that it can be easily seen by the operator) at a point that will give the operator sufficient time to stop the hoist to prevent two-blocking, and use a spotter who is in direct communication with the operator to inform the operator when this point is reached.

- (3) If using a personnel platform, paragraphs (b) through (n) of this section apply.
- (4) If using a boatswain's chair:
  - (i) The following paragraphs of this section apply: (a), (c), (d)(1), (d)(3), (d)(4), (e)(1), (e)(2), (e)(3), (f)(1), (f)(2)(i), (f)(3)(i), (g), (h), (j), (k)(1), (k)(6), (k)(8), (k)(9), (k)(11)(i), (m), and (n). Where the terms "personnel platform" or "platform" are used in these paragraphs, substitute them with "boatswain's chair."
  - (ii) The employee must be hoisted in a slow, controlled descent and ascent.
  - (iii) The employee must use personal fall protection equipment, including a full body harness, independently attached to the lower load block or overhaul ball.
  - (iv) The fall protection equipment must meet the applicable requirements in § 1926.502.
  - (v) The boatswain's chair itself (excluding the personal fall arrest system anchorages), must be capable of supporting, without failure, its own weight and at least five times the maximum intended load.
  - (vi) No more than one person must be hoisted at a time.

(q) *[Reserved.]*

(r) *Hoisting personnel for marine transfer.* When hoisting employees solely for transfer to or from a marine worksite, the following requirements must be met:

- (1) The employee must be in either a personnel platform or a marine-hoisted personnel transfer device.
- (2) If using a personnel platform, paragraphs (a) through (n) of this section apply.
- (3) If using a marine-hoisted personnel transfer device:
  - (i) The following paragraphs of this section apply: (a), (c)(2), (d)(1), (d)(3), (d)(4), (e)(1) through (5), (e)(12), (f)(1), (g), (h), (j), (k)(1), (k)(8), (k)(9), (k)(10)(ii), (k)(11)(i), (k)(12), (m), and (n). Where the terms “personnel platform” or “platform” are used in these paragraphs, substitute them with “marine-hoisted personnel transfer device.”
  - (ii) The transfer device must be used only for transferring workers.
  - (iii) The number of workers occupying the transfer device must not exceed the maximum number it was designed to hold.
  - (iv) Each employee must wear a U.S. Coast Guard personal flotation device approved for industrial use.

(s) *Hoisting personnel for storage-tank (steel or concrete), shaft and chimney operations.* When hoisting an employee in storage tank (steel or concrete), shaft and chimney operations, the following requirements must be met:

- (1) The employee must be in a personnel platform except when the employer can demonstrate that use of a personnel platform is infeasible; in such a case, a boatswain’s chair must be used.
- (2) If using a personnel platform, paragraphs (a) through (n) of this section apply.
- (3) If using a boatswain’s chair:
  - (i) The following paragraphs of this section apply: (a), (c), (d)(1), (d)(3), (d)(4), (e)(1), (e)(2), (e)(3), (f)(1), (f)(2)(i), (f)(3)(i), (g), (h), (k)(1), (k)(6), (k)(8), (k)(9), (k)(11)(i), (m), (n). Where the terms “personnel platform” or “platform” are used in these paragraphs, substitute them with “boatswain’s chair.”
  - (ii) The employee must be hoisted in a slow, controlled descent and ascent.
  - (iii) The employee must use personal fall protection equipment, including a full body harness, attached independent of the crane/derrick. When there is no adequate structure for attachment of personal fall arrest equipment as required in § 1926.502(d)(15), the attachment must be to the lower load block or overhaul ball.

- (iv) The fall protection equipment must meet the applicable requirements in § 1926.502.
- (v) The boatswain’s chair itself (excluding the personal fall arrest system anchorages), must be capable of supporting, without failure, its own weight and at least five times the maximum intended load.
- (vi) No more than one person must be hoisted at a time.

### **§ 1926.1432 Multiple-crane/derrick lifts—supplemental requirements**

(a) *Plan development.* Before beginning a crane/derrick operation in which more than one crane/derrick will be supporting the load, the operation must be planned. The planning must meet the following requirements:

- (1) The plan must be developed by a qualified person.
- (2) The plan must be designed to ensure that the requirements of this subpart are met.
- (3) Where the qualified person determines that engineering expertise is needed for the planning, the employer must ensure that it is provided.

(b) *Plan implementation.*

- (1) The multiple-crane/derrick lift must be directed by a person who meets the criteria for both a competent person and a qualified person, or by a competent person who is assisted by one or more qualified persons (lift director).
- (2) The lift director must review the plan in a meeting with all workers who will be involved with the operation.

### **§ 1926.1433 Design, construction and testing.**

The following requirements apply to equipment that has a manufacturer-rated hoisting/lifting capacity of more than 2,000 pounds.

- (a) Crawler, truck and locomotive cranes manufactured prior to November 8, 2010 must meet the applicable requirements for design, construction, and testing as prescribed in ANSI B30.5–1968 (incorporated by reference, *see* § 1926.6), PCSA Std. No. 2 (1968) (incorporated by reference, *see* § 1926.6), the requirements in paragraph (b) of this section, or the applicable DIN standards that were in effect at the time of manufacture.
- (b) Mobile (including crawler and truck) and locomotive cranes manufactured on or after November 8, 2010 must meet the following portions of ASME B30.5–2004 (incorporated by reference, *see* § 1926.6) as applicable:

- (1) In section 5-1.1.1 (“Load Ratings— Where Stability Governs Lifting Performance”), paragraphs (a)—(d) (including subparagraphs).
  - (2) In section 5-1.1.2 (“Load Ratings— Where Structural Competence Governs Lifting Performance”), paragraph (b).
  - (3) Section 5-1.2 (“Stability (Backward and Forward)”).
  - (4) In section 5-1.3.1 (“Boom Hoist Mechanism”), paragraphs (a), (b)(1) and (b)(2), except that when using rotation resistant rope, § 1926.1414(c)(4)(ii)(A) applies.
  - (5) In section 5-1.3.2 (“Load Hoist Mechanism”), paragraphs (a)(2) through (a)(4) (including subparagraphs), (b) (including subparagraphs), (c) (first sentence only) and (d).
  - (6) Section 5-1.3.3 (“Telescoping Boom”).
  - (7) Section 5-1.4 (“Swing Mechanism”).
  - (8) In section 5-1.5 (“Crane Travel”), all provisions except 5-1.5.3(d).
  - (9) In section 5-1.6 (“Controls”), all provisions except 5-1.6.1 (c).
  - (10) Section 5-1.7.4 (“Sheaves”).
  - (11) Section 5-1.7.5 (“Sheave sizes”).
  - (12) In section 5-1.9.1 (“Booms”), paragraph (f).
  - (13) Section 5-1.9.3 (“Outriggers”).
  - (14) Section 5-1.9.4 (“Locomotive Crane Equipment”).
  - (15) Section 5-1.9.7 (“Clutch and Brake Protection”).
  - (16) In section 5-1.9.11 (“Miscellaneous equipment”), paragraphs (a), (c), (e), and (f).
- (c) Prototype testing: mobile (including crawler and truck) and locomotive cranes manufactured on or after November 8, 2010 must meet the prototype testing requirements in Test Option A or Test Option B of this section. Tower cranes manufactured on or after November 8, 2010 must meet the prototype testing requirements in BS EN 14439:2006 (incorporated by reference, *see* § 1926.6).

**Note:** Prototype testing of crawler, locomotive and truck cranes manufactured prior to November 8, 2010 must conform to paragraph (a) of this section.

(1) *Test Option A.*

- (i) The following applies to equipment with cantilevered booms (such as hydraulic boom cranes): All the tests listed in SAE J1063 (Nov. 1993) Table 1 (incorporated by reference, *see* § 1926.6) must be performed to load all critical structural elements to their respective limits. All the strength margins listed in SAE

J1063 (Nov. 1993) Table 2 (incorporated by reference, *see* § 1926.6) must be met.

- (ii) The following applies to equipment with pendant supported lattice booms: All the tests listed in SAE J987 (Jun. 2003) Table 1 (incorporated by reference, *see* § 1926.6) must be performed to load all critical structural elements to their respective limits. All the strength margins listed in SAE J987 (Jun. 2003) Table 2 (incorporated by reference, *see* § 1926.6) must be met.
- (2) *Test Option B.* The testing and verification requirements of BS EN 13000:2004 (incorporated by reference, *see* § 1926.6) must be met. In applying BS EN 13000:2004, the following additional requirements must be met:
- (i) The following applies to equipment with cantilevered booms (such as hydraulic boom cranes): The analysis methodology (computer modeling) must demonstrate that all load cases listed in SAE J1063 (Nov. 1993) (incorporated by reference, *see* § 1926.6) meet the strength margins listed in SAE J1063 (Nov. 1993) Table 2.
  - (ii) The following applies to equipment with pendant supported lattice booms: The analysis methodology (computer modeling) must demonstrate that all load cases listed in SAE J987 (Jun. 2003) (incorporated by reference, *see* § 1926.6) meet the strength margins listed in SAE J987 (Jun. 2003) Table 2.
  - (iii) *Analysis verification.* The physical testing requirements under SAE J1063 (Nov. 1993) (incorporated by reference, *see* § 1926.6) and SAE J987 (Jun. 2003) (incorporated by reference, *see* § 1926.6) must be met unless the reliability of the analysis methodology (computer modeling) has been demonstrated by a documented history of verification through strain gauge measuring or strain gauge measuring in combination with other physical testing.
- (d) All equipment covered by this subpart must meet the following requirements:
- (1) Rated capacity and related information. The information available in the cab (*see* § 1926.1417(c)) regarding “rated capacity” and related information must include, at a minimum, the following information:
    - (i) A complete range of the manufacturer’s equipment rated capacities, as follows:
      - (A) At all manufacturer approved operating radii, boom angles, work areas, boom lengths and configurations, jib lengths and angles (or offset).



- (B) Alternate ratings for use and nonuse of option equipment which affects rated capacities, such as outriggers, stabilizers, and extra counterweights.
  - (ii) A work area chart for which capacities are listed in the load chart. (**Note:** An example of this type of chart is in ASME B30.5–2004, section 5–1.1.3, Figure 11).
  - (iii) The work area figure and load chart must clearly indicate the areas where no load is to be handled.
  - (iv) Recommended reeving for the hoist lines must be shown.
  - (v) Recommended parts of hoist reeving, size, and type of wire rope for various equipment loads.
  - (vi) Recommended boom hoist reeving diagram, where applicable; size, type and length of wire rope.
  - (vii) Tire pressure (where applicable).
  - (viii) Caution or warnings relative to limitations on equipment and operating procedures, including an indication of the least stable direction.
  - (ix) Position of the gantry and requirements for intermediate boom suspension (where applicable).
  - (x) Instructions for boom erection and conditions under which the boom, or boom and jib combinations, may be raised or lowered.
  - (xi) Whether the hoist holding mechanism is automatically or manually controlled, whether free fall is available, or any combination of these.
  - (xii) The maximum telescopic travel length of each boom telescopic section.
  - (xiii) Whether sections are telescoped manually or with power.
  - (xiv) The sequence and procedure for extending and retracting the telescopic boom section.
  - (xv) Maximum loads permitted during the boom extending operation, and any limiting conditions or cautions.
  - (xvi) Hydraulic relief valve settings specified by the manufacturer.
- (2) Load hooks (including latched and unlatched types), ball assemblies and load blocks must be of sufficient weight to overhaul the line from the highest hook position for boom or boom and jib lengths and the number of parts of the line in use.
- (3) Hook and ball assemblies and load blocks must be marked with their rated capacity and weight.
- (4) *Latching hooks.*
- (i) Hooks must be equipped with latches, except where the requirements of paragraph (d)(4)(ii) of this section are met.
  - (ii) Hooks without latches, or with latches removed or disabled, must not be used unless:
    - (A) A qualified person has determined that it is safer to hoist and place the load without latches (or with the latches removed/tied-back).
    - (B) Routes for the loads are pre-planned to ensure that no employee is required to work in the fall zone except for employees necessary for the hooking or unhooking of the load.
  - (iii) The latch must close the throat opening and be designed to retain slings or other lifting devices/accessories in the hook when the rigging apparatus is slack.
- (5) *Posted warnings.* Posted warnings required by this subpart as well as those originally supplied with the equipment by the manufacturer must be maintained in legible condition.
- (6) An accessible fire extinguisher must be on the equipment.
- (7) *Cabs.* Equipment with cabs must meet the following requirements:
- (i) Cabs must be designed with a form of adjustable ventilation and method for clearing the windshield for maintaining visibility and air circulation. Examples of means for adjustable ventilation include air conditioner or window that can be opened (for ventilation and air circulation); examples of means for maintaining visibility include heater (for preventing windshield icing), defroster, fan, windshield wiper.
  - (ii) Cab doors (swinging, sliding) must be designed to prevent inadvertent opening or closing while traveling or operating the machine. Swinging doors adjacent to the operator must open outward. Sliding operator doors must open rearward.
  - (iii) *Windows.*
    - (A) The cab must have windows in front and on both sides of the operator. Forward vertical visibility must be sufficient to give the operator a view of the boom point at all times.
    - (B) Windows may have sections designed to be opened or readily removed. Windows with sections designed to be opened must be designed so that they can be secured to prevent inadvertent closure.

- (C) Windows must be of safety glass or material with similar optical and safety properties, that introduce no visible distortion or otherwise obscure visibility that interferes with the safe operation of the equipment.
- (iv) A clear passageway must be provided from the operator's station to an exit door on the operator's side.
- (v) Areas of the cab roof that serve as a workstation for rigging, maintenance or other equipment-related tasks must be capable of supporting 250 pounds without permanent distortion.
- (8) Belts, gears, shafts, pulleys, sprockets, spindles, drums, fly wheels, chains, and other parts or components that reciprocate, rotate or otherwise move must be guarded where contact by employees (except for maintenance and repair employees) is possible in the performance of normal duties.
- (9) All exhaust pipes, turbochargers, and charge air coolers must be insulated or guarded where contact by employees (except for maintenance and repair employees) is possible in the performance of normal duties.
- (10) Hydraulic and pneumatic lines must be protected from damage to the extent feasible.
- (11) The equipment must be designed so that exhaust fumes are not discharged in the cab and are discharged in a direction away from the operator.
- (12) *Friction mechanisms.* Where friction mechanisms (such as brakes and clutches) are used to control the boom hoist or load line hoist, they must be:
  - (i) Of a size and thermal capacity sufficient to control all rated loads with the minimum recommended reeving.
  - (ii) Adjustable to permit compensation for lining wear to maintain proper operation.
- (13) *Hydraulic load hoists.* Hydraulic drums must have an integrally mounted holding device or internal static brake to prevent load hoist movement in the event of hydraulic failure.
- (e) The employer's obligations under paragraphs (a) through (c) and (d)(7) through (13) of this section are met where the equipment has not changed (except in accordance with § 1926.1434 (Equipment modifications)) and it can refer to documentation from the manufacturer showing that the equipment has been designed, constructed and tested in accordance with those paragraphs.

## § 1926.1434 Equipment modifications.

- (a) Modifications or additions which affect the capacity or safe operation of the equipment are prohibited except where the requirements of paragraphs (a)(1), (a)(2), (a)(3), (a)(4), or (a)(5) of this section are met.
  - (1) *Manufacturer review and approval.*
    - (i) The manufacturer approves the modifications/additions in writing.
    - (ii) The load charts, procedures, instruction manuals and instruction plates/tags/decals are modified as necessary to accord with the modification/addition.
    - (iii) The original safety factor of the equipment is not reduced.
  - (2) *Manufacturer refusal to review request.* The manufacturer is provided a detailed description of the proposed modification/addition, is asked to approve the modification/addition, but it declines to review the technical merits of the proposal or fails, within 30 days, to acknowledge the request or initiate the review, and all of the following are met:
    - (i) A registered professional engineer who is a qualified person with respect to the equipment involved:
      - (A) Approves the modification/ addition and specifies the equipment configurations to which that approval applies, and
      - (B) Modifies load charts, procedures, instruction manuals and instruction plates/tags/decals as necessary to accord with the modification/addition.
    - (ii) The original safety factor of the equipment is not reduced.
  - (3) *Unavailable manufacturer.* The manufacturer is unavailable and the requirements of paragraphs (a)(2)(i) and (ii) of this section are met.
  - (4) *Manufacturer does not complete the review within 120 days of the request.* The manufacturer is provided a detailed description of the proposed modification/addition, is asked to approve the modification/addition, agrees to review the technical merits of the proposal, but fails to complete the review of the proposal within 120 days of the date it was provided the detailed description of the proposed modification/addition, and the requirements of paragraphs (a)(2)(i) and (ii) of this section are met.
  - (5) *Multiple manufacturers of equipment designed for use on marine work sites.* The equipment is designed for marine work sites, contains major structural components from more than one manufacturer, and the requirements of paragraphs (a)(2)(i) and (ii) of this section are met.

- (b) Modifications or additions which affect the capacity or safe operation of the equipment are prohibited where the manufacturer, after a review of the technical safety merits of the proposed modification/addition, rejects the proposal and explains the reasons for the rejection in a written response. If the manufacturer rejects the proposal but does not explain the reasons for the rejection in writing, the employer may treat this as a manufacturer refusal to review the request under paragraph (a)(2) of this section.
- (c) The provisions in paragraphs (a) and (b) of this section do not apply to modifications made or approved by the U.S. military.

### § 1926.1435 Tower cranes.

- (a) This section contains supplemental requirements for tower cranes; all sections of this subpart apply to tower cranes unless specified otherwise.
- (b) *Erecting, climbing and dismantling.*
  - (1) Section 1926.1403 (Assembly/ Disassembly—selection of manufacturer or employer procedures), § 1926.1404 (Assembly/Disassembly—general requirements (applies to all assembly and disassembly operations)), § 1926.1405 (Disassembly—additional requirements for dismantling of booms and jibs (applies to both the use of manufacturer procedures and employer procedures)), and § 1926.1406 (Assembly/Disassembly—employer procedures—general requirements), apply to tower cranes (except as otherwise specified), except that the term “assembly/disassembly” is replaced by “erecting, climbing and dismantling,” and the term “disassembly” is replaced by “dismantling.”
  - (2) *Dangerous areas (self-erecting tower cranes).* In addition to the requirements in § 1926.1404(e), for self-erecting tower cranes, the following applies: Employees must not be in or under the tower, jib, or rotating portion of the crane during erecting, climbing and dismantling operations until the crane is secured in a locked position and the competent person in charge indicates it is safe to enter this area, unless the manufacturer’s instructions direct otherwise and only the necessary personnel are permitted in this area.
  - (3) *Foundations and structural supports.* Tower crane foundations and structural supports (including both the portions of the structure used for support and the means of attachment) must be designed by the manufacturer or a registered professional engineer.
  - (4) *Addressing specific hazards.* The requirements in § 1926.1404(h)(1) through (9) apply. In

addition, the A/D director must address the following:

- (i) *Foundations and structural supports.* The A/D director must determine that tower crane foundations and structural supports are installed in accordance with their design.
  - (ii) *Loss of backward stability.* Backward stability before swinging self erecting cranes or cranes on traveling or static undercarriages.
  - (iii) *Wind speed.* Wind must not exceed the speed recommended by the manufacturer or, where manufacturer does not specify this information, the speed determined by a qualified person.
- (5) *Plumb tolerance.* Towers must be erected plumb to the manufacturer’s tolerance and verified by a qualified person. Where the manufacturer does not specify plumb tolerance, the crane tower must be plumb to a tolerance of at least 1:500 (approximately 1 inch in 40 feet).
  - (6) *Multiple tower crane jobsites.* On jobsites where more than one fixed jib (hammerhead) tower crane is installed, the cranes must be located such that no crane can come in contact with the structure of another crane. Cranes are permitted to pass over one another.
  - (7) *Climbing procedures.* Prior to, and during, all climbing procedures (including inside climbing and top climbing), the employer must:
    - (i) Comply with all manufacturer prohibitions.
    - (ii) Have a registered professional engineer verify that the host structure is strong enough to sustain the forces imposed through the braces, brace anchorages and supporting floors.
  - (8) *Counterweight/ballast.*
    - (i) Equipment must not be erected, dismantled or operated without the amount and position of counterweight and/or ballast in place as specified by the manufacturer or a registered professional engineer familiar with the equipment.
    - (ii) The maximum counterweight and/ or ballast specified by the manufacturer or registered professional engineer familiar with the equipment must not be exceeded.
  - (c) *Signs.* The size and location of signs installed on tower cranes must be in accordance with manufacturer specifications. Where these are unavailable, a registered professional engineer familiar with the type of equipment involved must approve in writing the size and location of any signs.
  - (d) *Safety devices.*
    - (1) Section 1926.1415 does not apply to tower cranes.

- (2) The following safety devices are required on all tower cranes unless otherwise specified:
- (i) Boom stops on luffing boom type tower cranes.
  - (ii) Jib stops on luffing boom type tower cranes if equipped with a jib attachment.
  - (iii) Travel rail end stops at both ends of travel rail.
  - (iv) Travel rail clamps on all travel bogies.
  - (v) Integrally mounted check valves on all load supporting hydraulic cylinders.
  - (vi) Hydraulic system pressure limiting device.
  - (vii) The following brakes, which must automatically set in the event of pressure loss or power failure, are required:
    - (A) A hoist brake on all hoists.
    - (B) Swing brake.
    - (C) Trolley brake.
    - (D) Rail travel brake.
  - (viii) Deadman control or forced neutral return control (hand) levers.
  - (ix) Emergency stop switch at the operator's station.
  - (x) Trolley end stops must be provided at both ends of travel of the trolley.
- (3) *Proper operation required.* Operations must not begin unless the devices listed in this section are in proper working order. If a device stops working properly during operations, the operator must safely stop operations. The equipment must be taken out of service, and operations must not resume until the device is again working properly. See § 1926.1417(f). Alternative measures are not permitted to be used.
- (e) *Operational aids.*
- (1) Section 1926.1416 does not apply to tower cranes.
  - (2) The devices listed in this section ("operational aids") are required on all tower cranes covered by this subpart, unless otherwise specified.
  - (3) Operations must not begin unless the operational aids are in proper working order, except where the employer meets the specified temporary alternative measures. More protective alternative measures specified by the tower crane manufacturer, if any, must be followed. See § 1926.1417(j) for additional requirements.
  - (4) If an operational aid stops working properly during operations, the operator must safely stop operations until the temporary alternative measures are implemented or the device is again working properly. If a replacement part is no longer available, the use of a substitute device that performs the same type of function is permitted and is not considered a modification under § 1926.1434.
- (5) *Category I operational aids and alternative measures.* Operational aids listed in this paragraph that are not working properly must be repaired no later than 7 calendar days after the deficiency occurs. *Exception:* If the employer documents that it has ordered the necessary parts within 7 calendar days of the occurrence of the deficiency, the repair must be completed within 7 calendar days of receipt of the parts.
- (i) *Trolley travel limiting device.* The travel of the trolley must be restricted at both ends of the jib by a trolley travel limiting device to prevent the trolley from running into the trolley end stops. *Temporary alternative measures:*
    - (A) *Option A.* The trolley rope must be marked (so it can be seen by the operator) at a point that will give the operator sufficient time to stop the trolley prior to the end stops.
    - (B) *Option B.* A spotter who is in direct communication with the operator must be used when operations are conducted within 10 feet of the outer or inner trolley end stops.
  - (ii) *Boom hoist limiting device.* The range of the boom must be limited at the minimum and maximum radius. *Temporary alternative measures:* Clearly mark the cable (so it can be seen by the operator) at a point that will give the operator sufficient time to stop the boom hoist within the minimum and maximum boom radius, or use a spotter who is in direct communication with the operator to inform the operator when this point is reached.
  - (iii) *Anti two-blocking device.* The tower crane must be equipped with a device which automatically prevents damage from contact between the load block, overhaul ball, or similar component, and the boom tip (or fixed upper block or similar component). The device(s) must prevent such damage at all points where two-blocking could occur. *Temporary alternative measures:* Clearly mark the cable (so it can be seen by the operator) at a point that will give the operator sufficient time to stop the hoist to prevent two-blocking, or use a spotter who is in direct communication with the operator to inform the operator when this point is reached.
  - (iv) *Hoist drum lower limiting device.* Tower cranes manufactured after November 8, 2011 must be equipped with a device that prevents the last 2 wraps of hoist cable from being spooled off the drum. *Temporary alternative measures:* Mark the cable (so it can be seen

by the operator) at a point that will give the operator sufficient time to stop the hoist prior to last 2 wraps of hoist cable being spooled off the drum, or use a spotter who is in direct communication with the operator to inform the operator when this point is reached

- (v) *Load moment limiting device.* The tower crane must have a device that prevents moment overloading. *Temporary alternative measures:* A radius indicating device must be used (if the tower crane is not equipped with a radius indicating device, the radius must be measured to ensure the load is within the rated capacity of the crane). In addition, the weight of the load must be determined from a source recognized by the industry (such as the load's manufacturer), or by a calculation method recognized by the industry (such as calculating a steel beam from measured dimensions and a known per foot weight), or by other equally reliable means. This information must be provided to the operator prior to the lift.
  - (vi) *Hoist line pull limiting device.* The capacity of the hoist must be limited to prevent overloading, including each individual gear ratio if equipped with a multiple speed hoist transmission. *Temporary alternative measures:* The operator must ensure that the weight of the load does not exceed the capacity of the hoist (including for each individual gear ratio if equipped with a multiple speed hoist transmission).
  - (vii) *Rail travel limiting device.* The travel distance in each direction must be limited to prevent the travel bogies from running into the end stops or buffers. *Temporary alternative measures:* A spotter who is in direct communication with the operator must be used when operations are conducted within 10 feet of either end of the travel rail end stops; the spotter must inform the operator of the distance of the travel bogies from the end stops or buffers.
  - (viii) *Boom hoist drum positive locking device and control.* The boom hoist drum must be equipped with a control that will enable the operator to positively lock the boom hoist drum from the cab. *Temporary alternative measures:* The device must be manually set when required if an electric, hydraulic or automatic control is not functioning.
- (6) *Category II operational aids and alternative measures.* Operational aids listed in this paragraph that are not working properly must be repaired no later than 30 calendar days after the deficiency occurs. *Exception:* If the employer documents that it has ordered the necessary parts within 7 calendar days of the occurrence of the deficiency, and the part is not received in time to complete the repair in 30 calendar days, the repair must be completed within 7 calendar days of receipt of the parts.
- (i) *Boom angle or hook radius indicator.*
    - (A) Luffing boom tower cranes must have a boom angle indicator readable from the operator's station.
    - (B) Hammerhead tower cranes manufactured after November 8, 2011 must have a hook radius indicator readable from the operator's station.
    - (C) *Temporary alternative measures:* Hook radii or boom angle must be determined by measuring the hook radii or boom angle with a measuring device.
  - (ii) *Trolley travel deceleration device.* The trolley speed must be automatically reduced prior to the trolley reaching the end limit in both directions. *Temporary alternative measure:* The employer must post a notice in the cab of the crane notifying the operator that the trolley travel deceleration device is malfunctioning and instructing the operator to take special care to reduce the trolley speed when approaching the trolley end limits.
  - (iii) *Boom hoist deceleration device.* The boom speed must be automatically reduced prior to the boom reaching the minimum or maximum radius limit. *Temporary alternative measure:* The employer must post a notice in the cab of the crane notifying the operator that the boom hoist deceleration device is malfunctioning and instructing the operator to take special care to reduce the boom speed when approaching the minimum or maximum radius limits.
  - (iv) *Load hoist deceleration device.* The load speed must be automatically reduced prior to the hoist reaching the upper limit. *Temporary alternative measure:* The employer must post a notice in the cab of the crane notifying the operator that the load hoist deceleration device is malfunctioning and instructing the operator to take special care to reduce the load speed when approaching the upper limits.
  - (v) *Wind speed indicator.* A device must be provided to display the wind speed and must be mounted above the upper rotating structure on tower cranes. On self erecting cranes, it must be mounted at or above the jib level. *Temporary alternative measures:* Use of wind speed information from a properly functioning indicating device on another tower crane

on the same site, or a qualified person estimates the wind speed.

- (vi) *Load indicating device.* Cranes manufactured after November 8, 2011 must have a device that displays the magnitude of the load on the hook. Displays that are part of load moment limiting devices that display the load on the hook meet this requirement. *Temporary alternative measures:* The weight of the load must be determined from a source recognized by the industry (such as the load's manufacturer), or by a calculation method recognized by the industry (such as calculating a steel beam from measured dimensions and a known per foot weight), or by other equally reliable means. This information must be provided to the operator prior to the lift.

(f) *Inspections.*

- (1) Section 1926.1412 (Inspections) applies to tower cranes, except that the term "assembly" is replaced by "erection." Section 1926.1413 (Wire rope—inspection) applies to tower cranes.
- (2) *Pre-erection inspection.* Before each crane component is erected, it must be inspected by a qualified person for damage or excessive wear.
- (i) The qualified person must pay particular attention to components that will be difficult to inspect thoroughly during shift inspections.
- (ii) If the qualified person determines that a component is damaged or worn to the extent that it would create a safety hazard if used on the crane, that component must not be erected on the crane unless it is repaired and, upon reinspection by the qualified person, found to no longer create a safety hazard.
- (iii) If the qualified person determines that, though not presently a safety hazard, the component needs to be monitored, the employer must ensure that the component is checked in the monthly inspections. Any such determination must be documented, and the documentation must be available to any individual who conducts a monthly inspection.
- (3) *Post-erection inspection.* In addition to the requirements in § 1926.1412(c), the following requirements must be met:
- (i) A load test using certified weights, or scaled weights using a certified scale with a current certificate of calibration, must be conducted after each erection.
- (ii) The load test must be conducted in accordance with the manufacturer's instructions when available. Where these instructions are unavailable, the test must be conducted in accordance with written load test proce-

dures developed by a registered professional engineer familiar with the type of equipment involved.

- (4) *Monthly.* The following additional items must be included:
- (i) Tower (mast) bolts and other structural bolts (for loose or dislodged condition) from the base of the tower crane up or, if the crane is tied to or braced by the structure, those above the upper-most brace support.
- (ii) The upper-most tie-in, braces, floor supports and floor wedges where the tower crane is supported by the structure, for loose or dislodged components.
- (5) *Annual.* In addition to the items that must be inspected under § 1926.1412(f), all turntable and tower bolts must be inspected for proper condition and torque.

### § 1926.1436 Derricks.

- (a) This section contains supplemental requirements for derricks, whether temporarily or permanently mounted; all sections of this subpart apply to derricks unless specified otherwise. A derrick is powered equipment consisting of a mast or equivalent member that is held at or near the end by guys or braces, with or without a boom, and its hoisting mechanism. The mast/equivalent member and/or the load is moved by the hoisting mechanism (typically base-mounted) and operating ropes. Derricks include: A-frame, basket, breast, Chicago boom, gin pole (except gin poles used for erection of communication towers), guy, shearleg, stiffleg, and variations of such equipment.
- (b) *Operation—procedures.*
- (1) Section 1926.1417 (Operation) applies except for § 1926.1417(c) (Accessibility of procedures).
- (2) Load chart contents. Load charts must contain at least the following information:
- (i) Rated capacity at corresponding ranges of boom angle or operating radii.
- (ii) Specific lengths of components to which the rated capacities apply.
- (iii) Required parts for hoist reeving.
- (iv) Size and construction of rope must be included on the load chart or in the operating manual.
- (3) *Load chart location.*
- (i) *Permanent installations.* For permanently installed derricks with fixed lengths of boom, guy, and mast, a load chart must be posted where it is visible to personnel responsible for the operation of the equipment.
- (ii) *Non-permanent installations.* For derricks that are not permanently installed, the load

chart must be readily available at the job site to personnel responsible for the operation of the equipment.

(c) Construction.

(1) *General requirements.*

- (i) Derricks must be constructed to meet all stresses imposed on members and components when installed and operated in accordance with the manufacturer's/builder's procedures and within its rated capacity.
- (ii) Welding of load sustaining members must conform to recommended practices in ANSI/AWS D14.3-94 (incorporated by reference, see § 1926.6) or AWS D1.1/D1.1M:2002 (incorporated by reference, see § 1926.6).

(2) *Guy derricks.*

- (i) The minimum number of guys must be 6, with equal spacing, except where a qualified person or derrick manufacturer approves variations from these requirements and revises the rated capacity to compensate for such variations.
- (ii) Guy derricks must not be used unless the employer has the following guy information from the manufacturer or a qualified person, when not available from the manufacturer:
  - (A) The number of guys.
  - (B) The spacing around the mast.
  - (C) The size, grade, and construction of rope to be used for each guy.
- (iii) For guy derricks manufactured after December 18, 1970, in addition to the information required in paragraph (c)(2)(ii) of this section, the employer must have the following guy information from the manufacturer or a qualified person, when not available from the manufacturer:
  - (A) The amount of initial sag or tension.
  - (B) The amount of tension in guy line rope at anchor.
- (iv) The mast base must permit the mast to rotate freely with allowance for slight tilting of the mast caused by guy slack.
- (v) The mast cap must:
  - (A) Permit the mast to rotate freely.
  - (B) Withstand tilting and cramping caused by the guy loads.
  - (C) Be secured to the mast to prevent disengagement during erection.
  - (D) Be provided with means for attaching guy ropes.

(3) *Stiffleg derricks.*

- (i) The mast must be supported in the vertical position by at least two stifflegs; one end of

each must be connected to the top of the mast and the other end securely anchored.

- (ii) The stifflegs must be capable of withstanding the loads imposed at any point of operation within the load chart range.
- (iii) The mast base must:
  - (A) Permit the mast to rotate freely (when necessary).
  - (B) Permit deflection of the mast without binding.
- (iv) The mast must be prevented from lifting out of its socket when the mast is in tension.
- (v) The stiffleg connecting member at the top of the mast must:
  - (A) Permit the mast to rotate freely (when necessary).
  - (B) Withstand the loads imposed by the action of the stifflegs.
  - (C) Be secured so as to oppose separating forces.

(4) *Gin pole derricks.*

- (i) Guy lines must be sized and spaced so as to make the gin pole stable in both boomed and vertical positions. *Exception:* Where the size and/or spacing of guy lines do not result in the gin pole being stable in both boomed and vertical positions, the employer must ensure that the derrick is not used in an unstable position.
- (ii) The base of the gin pole must permit movement of the pole (when necessary).
- (iii) The gin pole must be anchored at the base against horizontal forces (when such forces are present).

(5) *Chicago boom derricks.* The fittings for stepping the boom and for attaching the topping lift must be arranged to:

- (i) Permit the derrick to swing at all permitted operating radii and mounting heights between fittings.
- (ii) Accommodate attachment to the upright member of the host structure.
- (iii) Withstand the forces applied when configured and operated in accordance with the manufacturer's/ builder's procedures and within its rated capacity.
- (iv) Prevent the boom or topping lift from lifting out under tensile forces.

(d) *Anchoring and guying.*

- (1) Load anchoring data developed by the manufacturer or a qualified person must be used.
- (2) *Guy derricks.*
  - (i) The mast base must be anchored.

- (ii) The guys must be secured to the ground or other firm anchorage.
  - (iii) The anchorage and guying must be designed to withstand maximum horizontal and vertical forces encountered when operating within rated capacity with the particular guy slope and spacing specified for the application.
- (3) *Stiffleg derricks.*
- (i) The mast base and stifflegs must be anchored.
  - (ii) The mast base and stifflegs must be designed to withstand maximum horizontal and vertical forces encountered when operating within rated capacity with the particular stiffleg spacing and slope specified for the application.
- (e) *Swingers and hoists.*
- (1) The boom, swinger mechanisms and hoists must be suitable for the derrick work intended and must be anchored to prevent displacement from the imposed loads.
  - (2) *Hoists.*
    - (i) Base mounted drum hoists must meet the requirements in the following sections of ASME B30.7-2001 (incorporated by reference, see § 1926.6):
      - (A) Sections 7-1.1 (“Load ratings and markings”).
      - (B) Section 7-1.2 (“Construction”), except: 7-1.2.13 (“Operator’s cab”); 7-1.2.15 (“Fire extinguishers”).
      - (C) Section 7-1.3 (“Installation”).
      - (D) Applicable terms in section 7-0.2 (“Definitions”).
    - (ii) *Load tests for new hoists.* The employer must ensure that new hoists are load tested to a minimum of 110% of rated capacity, but not more than 125% of rated capacity, unless otherwise recommended by the manufacturer. This requirement is met where the manufacturer has conducted this testing.
    - (iii) *Repaired or modified hoists.* Hoists that have had repairs, modifications or additions affecting their capacity or safe operation must be evaluated by a qualified person to determine if a load test is necessary. If it is, load testing must be conducted in accordance with paragraphs (e)(2)(ii) and (iv) of this section.
    - (iv) *Load test procedure.* Load tests required by paragraphs (e)(2)(ii) or (e)(2)(iii) of this section must be conducted as follows:
      - (A) The test load must be hoisted a vertical distance to assure that the load is supported by the hoist and held by the hoist brake(s).
      - (B) The test load must be lowered, stopped and held with the brake(s).
      - (C) The hoist must not be used unless a competent person determines that the test has been passed.
- (f) *Operational aids.*
- (1) Section 1926.1416 (Operational aids) applies, except for § 1926.1416(d)(1) (Boom hoist limiting device), § 1926.1416(e)(1) (Boom angle or radius indicator), and § 1926.1416(e)(4) (Load weighing and similar devices).
  - (2) *Boom angle aid.* A boom angle indicator is not required but if the derrick is not equipped with a functioning one, the employer must ensure that either:
    - (i) The boom hoist cable must be marked with caution and stop marks. The stop marks must correspond to maximum and minimum allowable boom angles. The caution and stop marks must be in view of the operator, or a spotter who is in direct communication with the operator; or
    - (ii) An electronic or other device that signals the operator in time to prevent the boom from moving past its maximum and minimum angles, or automatically prevents such movement, is used.
  - (3) *Load weight/capacity devices.*
    - (i) Derricks manufactured more than one year after November 8, 2010 with a maximum rated capacity over 6,000 pounds must have at least one of the following: load weighing device, load moment indicator, rated capacity indicator, or rated capacity limiter. *Temporary alternative measures:* The weight of the load must be determined from a source recognized by the industry (such as the load’s manufacturer), or by a calculation method recognized by the industry (such as calculating a steel beam from measured dimensions and a known per foot weight), or by other equally reliable means. This information must be provided to the operator prior to the lift. See § 1926.1417(j) for additional requirements.
    - (ii) A load weight/capacity device that is not working properly must be repaired no later than 30 days after the deficiency occurs. *Exception:* If the employer documents that it has ordered the necessary parts within 7 days of the occurrence of the deficiency, and the part is not received in time to complete the repair in 30 days, the repair must be completed within 7 days of receipt of the parts.
- (g) *Post-assembly approval and testing—new or reinstalled derricks.*



- (1) *Anchorage*s.
- (i) Anchorages, including the structure to which the derrick is attached (if applicable), must be approved by a qualified person.
  - (ii) If using a rock or hairpin anchorage, the qualified person must determine if any special testing of the anchorage is needed. If so, it must be tested accordingly.
- (2) *Functional test*. Prior to initial use, new or reinstalled derricks must be tested by a competent person with no hook load to verify proper operation. This test must include:
- (i) Lifting and lowering the hook(s) through the full range of hook travel.
  - (ii) Raising and lowering the boom through the full range of boom travel.
  - (iii) Swinging in each direction through the full range of swing.
  - (iv) Actuating the anti two-block and boom hoist limit devices (if provided).
  - (v) Actuating locking, limiting and indicating devices (if provided).
- (3) *Load test*. Prior to initial use, new or reinstalled derricks must be load tested by a competent person. The test load must meet the following requirements:
- (i) Test loads must be at least 100% and no more than 110% of the rated capacity, unless otherwise recommended by the manufacturer or qualified person, but in no event must the test load be less than the maximum anticipated load.
  - (ii) The test must consist of:
    - (A) Hoisting the test load a few inches and holding to verify that the load is supported by the derrick and held by the hoist brake(s).
    - (B) Swinging the derrick, if applicable, the full range of its swing, at the maximum allowable working radius for the test load.
    - (C) Booming the derrick up and down within the allowable working radius for the test load.
    - (D) Lowering, stopping and holding the load with the brake(s).
  - (iii) The derrick must not be used unless the competent person determines that the test has been passed.
- (4) *Documentation*. Tests conducted under this paragraph must be documented. The document must contain the date, test results and the name of the tester. The document must be retained until the derrick is re-tested or dismantled, whichever occurs first. All such documents must be available, during the applicable document retention period, to all persons who conduct inspections in accordance with § 1926.1412.
- (h) *Load testing repaired or modified derricks*. Derricks that have had repairs, modifications or additions affecting the derrick's capacity or safe operation must be evaluated by a qualified person to determine if a load test is necessary. If it is, load testing must be conducted and documented in accordance with paragraph (g) of this section.
- (i) *[Reserved.]*
- (j) *Power failure procedures*. If power fails during operations, the derrick operator must safely stop operations. This must include:
- (1) Setting all brakes or locking devices.
  - (2) Moving all clutch and other power controls to the off position.
- (k) *Use of winch heads*.
- (1) Ropes must not be handled on a winch head without the knowledge of the operator.
  - (2) While a winch head is being used, the operator must be within reach of the power unit control lever.
- (l) *[Reserved.]*
- (m) *Securing the boom*.
- (1) When the boom is being held in a fixed position, dogs, pawls, or other positive holding mechanisms on the boom hoist must be engaged.
  - (2) When taken out of service for 30 days or more, the boom must be secured by one of the following methods:
    - (i) Laid down.
    - (ii) Secured to a stationary member, as nearly under the head as possible, by attachment of a sling to the load block.
    - (iii) For guy derricks, lifted to a vertical position and secured to the mast.
    - (iv) For stiffleg derricks, secured against the stiffleg.
- (n) The process of jumping the derrick must be supervised by the A/D director.
- (o) Derrick operations must be supervised by a competent person.
- (p) *Inspections*. In addition to the requirements in § 1926.1412, the following additional items must be included in the inspections:
- (1) *Daily*: Guys for proper tension.
  - (2) *Annual*.
    - (i) Gudgeon pin for cracks, wear, and distortion.
    - (ii) Foundation supports for continued ability to sustain the imposed loads.
- (q) *Qualification and Training*. The employer must train each operator of a derrick on the safe operation

of equipment the individual will operate. Section 1926.1427 of this subpart (Operator qualification and certification) does not apply.

### § 1926.1437 Floating cranes/derricks and land cranes/derricks on barges.

- (a) This section contains supplemental requirements for floating cranes/derricks and land cranes/derricks on barges, pontoons, vessels or other means of flotation (*i.e.*, vessel/ flotation device). The sections of this subpart apply to floating cranes/derricks and land cranes/derricks on barges, pontoons, vessels or other means of flotation, unless specified otherwise. The requirements of this section do not apply when using jacked barges when the jacks are deployed to the river, lake, or sea bed and the barge is fully supported by the jacks.
- (b) *General requirements.* The requirements in paragraphs (c) through (k) of this section apply to both floating cranes/derricks and land cranes/derricks on barges, pontoons, vessels or other means of flotation.
- (c) *Work area control.*
  - (1) The requirements of § 1926.1424 (Work area control) apply, except for § 1926.1424(a)(2)(ii).
  - (2) The employer must either:
    - (i) Erect and maintain control lines, warning lines, railings or similar barriers to mark the boundaries of the hazard areas; or
    - (ii) Clearly mark the hazard areas by a combination of warning signs (such as, “Danger—Swing/Crush Zone”) and high visibility markings on the equipment that identify the hazard areas. In addition, the employer must train each employee to understand what these markings signify.
- (d) *Keeping clear of the load.* Section 1926.1425 does not apply.
- (e) *Additional safety devices.* In addition to the safety devices listed in § 1926.1415, the following safety devices are required:
  - (1) Barge, pontoon, vessel or other means of flotation list and trim device. The safety device must be located in the cab or, when there is no cab, at the operator’s station.
  - (2) Positive equipment house lock.
  - (3) *Wind speed and direction indicator.* A competent person must determine if wind is a factor that needs to be considered; if wind needs to be considered, a wind speed and direction indicator must be used.
- (f) *Operational aids.*
  - (1) An anti two-block device is required only when hoisting personnel or hoisting over an occupied cofferdam or shaft.
  - (2) Section 1926.1416(e)(4) (Load weighing and similar devices) does not apply to dragline, clamshell (grapple), magnet, drop ball, container handling, concrete bucket, and pile driving work performed under this section.
- (g) *Accessibility of procedures applicable to equipment operation.* If the crane/derrick has a cab, the requirements of § 1926.1417(c) apply. If the crane/derrick does not have a cab, the employer must ensure that:
  - (1) Rated capacities (load charts) are posted at the operator’s station. If the operator’s station is moveable (such as with pendant-controlled equipment), the load charts are posted on the equipment.
  - (2) Procedures applicable to the operation of the equipment (other than load charts), recommended operating speeds, special hazard warnings, instructions and operators manual, must be readily available on board the vessel/flotation device.
- (h) *Inspections.* In addition to meeting the requirements of § 1926.1412 for inspecting the crane/derrick, the employer must inspect the barge, pontoons, vessel or other means of flotation used to support a floating crane/derrick or land crane/derrick, and ensure that:
  - (1) *Shift.* For each shift inspection, the means used to secure/attach the equipment to the vessel/flotation device is in proper condition, including wear, corrosion, loose or missing fasteners, defective welds, and (when applicable) insufficient tension.
  - (2) *Monthly.* For each monthly inspection:
    - (i) The means used to secure/attach the equipment to the vessel/flotation device is in proper condition, including inspection for wear, corrosion, and, when applicable, insufficient tension.
    - (ii) The vessel/flotation device is not taking on water.
    - (iii) The deckload is properly secured.
    - (iv) The vessel/flotation device is watertight based on the condition of the chain lockers, storage, fuel compartments, and hatches.
    - (v) The firefighting and lifesaving equipment is in place and functional.
  - (3) The shift and monthly inspections are conducted by a competent person, and:
    - (i) If any deficiency is identified, an immediate determination is made by a qualified person whether the deficiency constitutes a hazard.

- (ii) If the deficiency is determined to constitute a hazard, the vessel/flotation device is removed from service until the deficiency has been corrected.
- (4) *Annual: external vessel/flotation device inspection.* For each annual inspection:
- (i) The external portion of the barge, pontoons, vessel or other means of flotation used is inspected annually by a qualified person who has expertise with respect to vessels/flotation devices and that the inspection includes the following items:
    - (A) The items identified in paragraphs (h)(1) (*Shift*) and (h)(2) (*Monthly*) of this section.
    - (B) Cleats, bits, chocks, fenders, capstans, ladders, and stanchions, for significant corrosion, wear, deterioration, or deformation that could impair the function of these items.
    - (C) External evidence of leaks and structural damage; evidence of leaks and damage below the waterline may be determined through internal inspection of the vessel/flotation device.
    - (D) Four-corner draft readings.
    - (E) Firefighting equipment for serviceability.
  - (ii) Rescue skiffs, lifelines, work vests, life preservers and ring buoys are inspected for proper condition.
  - (iii) If any deficiency is identified, an immediate determination is made by the qualified person whether the deficiency constitutes a hazard or, though not yet a hazard, needs to be monitored in the monthly inspections.
    - (A) If the qualified person determines that the deficiency constitutes a hazard, the vessel/flotation device is removed from service until it has been corrected. *See* requirements in § 1926.1417(f).
    - (B) If the qualified person determines that, though not presently a hazard, the deficiency needs to be monitored, the deficiency is checked in the monthly inspections.
- (5) *Four-year: internal vessel/flotation device inspection.* For each four-year inspection:
- (i) A marine engineer, marine architect, licensed surveyor, or other qualified person who has expertise with respect to vessels/flotation devices surveys the internal portion of the barge, pontoons, vessel, or other means of flotation.
  - (ii) If the surveyor identifies a deficiency, an immediate determination is made by the surveyor as to whether the deficiency constitutes a hazard or, though not yet a hazard, needs to be monitored in the monthly or annual inspections, as appropriate.
    - (A) If the surveyor determines that the deficiency constitutes a hazard, the vessel/flotation device is removed from service until it has been corrected.
    - (B) If the surveyor determines that, though not presently a hazard, the deficiency needs to be monitored, the deficiency is checked in the monthly or annual inspections, as appropriate.
- (6) *Documentation.* The monthly and annual inspections required in paragraphs (h)(2) and (h)(4) of this section are documented in accordance with §§ 1926.1412 (e)(3) and 1926.1412(f)(7), respectively, and that the four-year inspection required in paragraph (h)(5) of this section is documented in accordance with § 1926.1412(f)(7), except that the documentation for that inspection must be retained for a minimum of 4 years. All such documents must be made available, during the applicable document retention period, to all persons who conduct inspections in accordance with § 1926.1412.
- (i) [*Reserved.*]
  - (j) *Working with a diver.* The employer must meet the following additional requirements when working with a diver in the water:
    - (1) If a crane/derrick is used to get a diver into and out of the water, it must not be used for any other purpose until the diver is back on board. When used for more than one diver, it must not be used for any other purpose until all divers are back on board.
    - (2) The operator must remain at the controls of the crane/derrick at all times.
    - (3) In addition to the requirements in §§ 1926.1419 through 1926.1422 (Signals), either:
      - (i) A clear line of sight must be maintained between the operator and tender; or
      - (ii) The signals between the operator and tender must be transmitted electronically.
    - (4) The means used to secure the crane/derrick to the vessel/flotation device (*see* paragraph (n)(5) of this section) must not allow any amount of shifting in any direction.
  - (k) *Manufacturer's specifications and limitations.*
    - (1) The employer must ensure that the barge, pontoons, vessel, or other means of flotation must be capable of withstanding imposed environmental, operational and in-transit loads when

used in accordance with the manufacturer's specifications and limitations.

- (2) The employer must ensure that the manufacturer's specifications and limitations with respect to environmental, operational, and in-transit loads for a barge, pontoon, vessel, or other means of flotation are not exceeded or violated.
- (3) When the manufacturer's specifications and limitations are unavailable, the employer must ensure that the specifications and limitations established by a qualified person with respect to environmental, operational and in-transit loads for the barge, pontoons, vessel, or other means of flotation are not exceeded or violated.

(l) [Reserved.]

(m) *Floating cranes/derricks.* For equipment designed by the manufacturer (or employer) for marine use by permanent attachment to barges, pontoons, vessels or other means of flotation:

- (1) *Load charts.*
  - (i) The employer must not exceed the manufacturer load charts applicable to operations on water. When using these charts, the employer must comply with all parameters and limitations (such as dynamic and environmental parameters) applicable to the use of the charts.
  - (ii) The employer must ensure that load charts take into consideration a minimum wind speed of 40 miles per hour.
- (2) The employer must ensure that the requirements for maximum allowable list and maximum allowable trim as specified in Table M1 of this section are met.

**TABLE M1**

Rated capacity	Maximum allowable list (degrees)	Maximum allowable trim (degrees)
<i>Equipment designed for marine use by permanent attachment (other than derricks):</i>		
25 tons or less .....	5	5
Over 25 tons .....	7	7
<i>Derricks designed for marine use by permanent attachment:</i>		
Any rated capacity ....	10	10

(3) The employer must ensure that the equipment is stable under the conditions specified in Tables M2 and M3 of this section. (**Note:** Freeboard is the vertical distance between the water line and the main deck of the vessel.)

**TABLE M2**

Operated at	Wind speed (mph)	Minimum freeboard (ft)
Rated capacity .....	60	2
Rated capacity plus 25% .....	60	1
High boom, no load .....	60	2

**TABLE M3**

Operated at	Wind speed
<i>For backward stability of the boom:</i>	
High boom, no load, full back list (least stable condition).	90

- (4) If the equipment is employer-made, it must not be used unless the employer has documents demonstrating that the load charts and applicable parameters for use meet the requirements of paragraphs (m)(1) through (3) of this section. Such documents must be signed by a registered professional engineer who is a qualified person with respect to the design of this type of equipment (including the means of flotation).
- (5) The employer must ensure that the barge, pontoons, vessel or other means of flotation used:
  - (i) Are structurally sufficient to withstand the static and dynamic loads of the crane/derrick when operating at the crane/derrick's maximum rated capacity with all planned and actual deck loads and ballasted compartments.
  - (ii) Have a subdivided hull with one or more longitudinal watertight bulkheads for reducing the free-surface effect.
  - (iii) Have access to void compartments to allow for inspection and pumping.
- (n) *Land cranes/derricks.* For land cranes/derricks used on barges, pontoons, vessels or other means of flotation, the employer must ensure that:
  - (1) The rated capacity of the equipment (including but not limited to modification of load charts) applicable for use on land is reduced to:
    - (i) Account for increased loading from list, trim, wave action, and wind.
    - (ii) Be applicable to a specified location(s) on the specific barge, pontoons, vessel or other means of flotation that will be used, under the environmental conditions expected and encountered.

- (iii) The conditions required in paragraphs (n)(3) and (n)(4) of this section are met.
- (2) The rated capacity modification required in paragraph (n)(1) of this section is performed by the equipment manufacturer, or a qualified person who has expertise with respect to both land crane/derrick capacity and the stability of vessels/flotation devices.
- (3) For list and trim.
  - (i) The maximum allowable list and the maximum allowable trim for the barge, pontoon, vessel or other means of flotation must not exceed the amount necessary to ensure that the conditions in paragraph (n)(4) of this section are met. In addition, the maximum allowable list and the maximum allowable trim does not exceed the least of the following: 5 degrees, the amount specified by the crane/derrick manufacturer, or, when, an amount is not so specified, the amount specified by the qualified person.
  - (ii) The maximum allowable list and the maximum allowable trim for the land crane/derrick does not exceed the amount specified by the crane/derrick manufacturer, or, when, an amount is not so specified, the amount specified by the qualified person.
- (4) For the following conditions:
  - (i) All deck surfaces of the barge, pontoons, vessel or other means of flotation used are above water.
  - (ii) The entire bottom area of the barge, pontoons, vessel or other means of flotation used is submerged.
- (5) Physical attachment, corraling, rails system and centerline cable system meet the requirements in Option (1), Option (2), Option (3), or Option (4) of this section, and that whichever option is used also meets the requirements of paragraph (n)(5)(v) of this section.
  - (i) *Option (1)—Physical attachment.* The crane/derrick is physically attached to the barge, pontoons, vessel or other means of flotation. Methods of physical attachment include crossed-cable systems attached to the crane/derrick and vessel/flotation device, bolting or welding the crane/derrick to the vessel/flotation device, strapping the crane/derrick to the vessel/flotation device with chains, or other methods of physical attachment.
  - (ii) *Option (2)—Corralling.* The crane/derrick is prevented from shifting by installing barricade restraints (i.e., a corraling system). Employers must ensure that corraling systems do not allow the equipment to shift by any amount of shifting in any direction.
- (iii) *Option (3)—Rails.* The crane/derrick must be prevented from shifting by being mounted on a rail system. Employers must ensure that rail clamps and rail stops are used unless the system is designed to prevent movement during operation by other means.
- (iv) *Option (4)—Centerline cable system.* The crane/derrick is prevented from shifting by being mounted to a wire rope system. The employer must ensure that the wire rope system meets the following requirements:
  - (A) The wire rope and attachments are of sufficient size and strength to support the side load of crane/derrick.
  - (B) The wire rope is attached physically to the vessel/flotation device.
  - (C) The wire rope is attached to the crane/derrick by appropriate attachment methods (such as shackles or sheaves) on the undercarriage, and that the method used will allow the crew to secure the crane/derrick from movement during operation and to move the crane/derrick longitudinally along the vessel/flotation device for repositioning.
  - (D) Means are installed to prevent the crane/derrick from passing the forward or aft end of the wire rope attachments.
  - (E) The crane/derrick is secured from movement during operation.
- (v) The systems/means used to comply with Option (1), Option (2), Option (3), or Option (4) of this section are designed by a marine engineer, registered professional engineer familiar with floating crane/derrick design, or qualified person familiar with floating crane/derrick design.
- (6) *Exception.* For mobile auxiliary cranes used on the deck of a floating crane/derrick, the requirement specified by paragraph (n)(5) of this section to use Option (1), Option (2), Option (3), or Option (4) does not apply when the employer demonstrates implementation of a plan and procedures that meet the following requirements:
  - (i) A marine engineer or registered professional engineer familiar with floating crane/derrick design develops and signs a written plan for the use of the mobile auxiliary crane.
  - (ii) The plan is designed so that the applicable requirements of this section are met despite the position, travel, operation, and lack of physical attachment (or corraling, use of rails or cable system) of the mobile auxiliary crane.
  - (iii) The plan specifies the areas of the deck where the mobile auxiliary crane is permitted to be positioned, travel, and operate, and the

parameters and limitations of such movements and operation.

- (iv) The deck is marked to identify the permitted areas for positioning, travel, and operation.
  - (v) The plan specifies the dynamic and environmental conditions that must be present for use of the plan.
  - (vi) If the dynamic and environmental conditions in paragraph (n)(6)(v) of this section are exceeded, the mobile auxiliary crane is attached physically or corralled in accordance with Option (1), Option (2) or Option (4) of paragraph (n)(5) of this section.
- (7) The barge, pontoons, vessel or other means of flotation used:
- (i) Are structurally sufficient to withstand the static and dynamic loads of the crane/derrick when operating at the crane/derrick's maximum rated capacity with all anticipated deck loads and ballasted compartments.
  - (ii) Have a subdivided hull with one or more longitudinal watertight bulkheads for reducing the free surface effect.
  - (iii) Have access to void compartments to allow for inspection and pumping.

### § 1926.1438 Overhead & gantry cranes.

- (a) *Permanently installed overhead and gantry cranes.* The requirements of § 1910.179, except for § 1910.179(b)(1), and not the requirements of this subpart CC, apply to the following equipment when used in construction and permanently installed in a facility: overhead and gantry cranes, including semigantry, cantilever gantry, wall cranes, storage bridge cranes, and others having the same fundamental characteristics.
- (b) *Overhead and gantry cranes that are not permanently installed in a facility.*
  - (1) This paragraph applies to the following equipment when used in construction and not permanently installed in a facility: Overhead and gantry cranes, overhead/bridge cranes, semigantry, cantilever gantry, wall cranes, storage bridge cranes, launching gantry cranes, and similar equipment having the same fundamental characteristics, irrespective of whether it travels on tracks, wheels, or other means.
  - (2) The following requirements apply to equipment identified in paragraph (b)(1) of this section:
    - (i) Sections 1926.1400 through 1926.1414; §§ 1926.1417 through 1926.1425; § 1926.1426(d), §§ 1926.1427 through 1926.1434; § 1926.1437, § 1926.1439, and § 1926.1441.
    - (ii) The following portions of § 1910.179:

- (A) Paragraphs (b)(5),(6),(7); (e) (1),(3),(5),(6); (f)(1),(4); (g); (h)(1),(3); (k); and (n) of § 1910.179.
  - (B) The definitions in § 1910.179(a) except for “hoist” and “load.” For those words, the definitions in § 1926.1401 apply.
  - (C) Section 1910.179(b)(2), but only where the equipment identified in paragraph (b)(1) of this section (§ 1926.1438) was manufactured before September 19, 2001.
- (iii) For equipment manufactured on or after September 19, 2001, the following sections of ASME B30.2-2005 (incorporated by reference, see § 1926.6) apply: 2-1.3.1; 2-1.3.2; 2-1.4.1; 2-1.6; 2-1.7.2; 2-1.8.2; 2-1.9.1; 2-1.9.2; 2-1.11; 2-1.12.2; 2-1.13.7; 2-1.14.2; 2-1.14.3; 2-1.14.5; 2-1.15.; 2-2.2.2; 2-3.2.1.1. In addition, 2-3.5 applies, except in 2-3.5.1(b), “29 CFR 1910.147” is substituted for “ANSI Z244.1.”

### § 1926.1439 Dedicated pile drivers.

- (a) The provisions of subpart CC apply to dedicated pile drivers, except as specified in this section.
- (b) Section 1926.1416(d)(3) (Anti two-blocking device) does not apply.
- (c) Section 1926.1416(e)(4) (Load weighing and similar devices) applies only to dedicated pile drivers manufactured after November 8, 2011.
- (d) In § 1926.1433, only §§ 1926.1433(d) and (e) apply to dedicated pile drivers.

### § 1926.1440 Sideboom cranes.

- (a) The provisions of this standard apply, except § 1926.1402 (Ground conditions), § 1926.1415 (Safety devices), § 1926.1416 (Operational aids), and § 1926.1427 (Operator qualification and certification).
- (b) Section 1926.1426 (Free fall and controlled load lowering) applies, except § 1926.1426(a)(2)(i). Sideboom cranes in which the boom is designed to free fall (live boom) are permitted only if manufactured prior to November 8, 2010.
- (c) Sideboom cranes mounted on wheel or crawler tractors must meet all of the following requirements of ASME B30.14-2004 (incorporated by reference, see § 1926.6):
  - (1) Section 14-1.1 (“Load Ratings”).
  - (2) Section 14-1.3 (“Side Boom Tractor Travel”).
  - (3) Section 14-1.5 (“Ropes and Reeving Accessories”).
  - (4) Section 14-1.7.1 (“Booms”).
  - (5) Section 14-1.7.2 (“General Requirements—Exhaust Gases”).

- (6) Section 14-1.7.3 (“General Requirements—Stabilizers (Wheel-Type Side Boom Tractors)”).
- (7) Section 14-1.7.4 (“General Requirements—Welded Construction”).
- (8) Section 14-1.7.6 (“General Requirements—Clutch and Brake Protection”).
- (9) Section 14-2.2.2 (“Testing—Rated Load Test”), except that it applies only to equipment that has been altered or modified.
- (10) In section 14-3.1.2 (“Operator Qualifications”), paragraph (a), except the phrase “When required by law.”
- (11) In section 14-3.1.3 (“Operating Practices”), paragraphs (e), (f)(1)—(f)(4), (f)(6), (f)(7), (h), and (i).
- (12) In section 14-3.2.3 (“Moving the Load”), paragraphs (j), (l), and (m).

### § 1926.1441 Equipment with a rated hoisting/lifting capacity of 2,000 pounds or less.

The following paragraphs of this section specify requirements for employers using equipment with a maximum rated hoisting/lifting capacity of 2,000 pounds or less.

- (a) The employer using this equipment must comply with the following provisions of this subpart: § 1926.1400 (Scope); § 1926.1401 (Definitions); § 1926.1402 (Ground conditions); § 1926.1403 (Assembly/ disassembly—selection of manufacturer or employer procedures); § 1926.1406 (Assembly/disassembly—employer procedures); §§ 1926.1407 through 1926.1411 (Power line safety); § 1926.1412(c) (*Post-assembly*); §§ 1926.1413 through 1926.1414 (Wire rope); § 1926.1418 (Authority to stop operation); §§ 1926.1419 through 1926.1422 (Signals); § 1926.1423 (Fall protection); § 1926.1425 (Keeping clear of the load) (except for § 1926.1425(c)(3) (qualified rigger)); § 1926.1426 (Free fall and controlled load lowering); § 1926.1432 (Multiple crane/derrick lifts—supplemental requirements); § 1926.1434 (Equipment modifications); § 1926.1435 (Tower cranes); § 1926.1436 (Derricks); § 1926.1437 (Floating cranes/ derricks and land cranes/derricks on barges); § 1926.1438 (Overhead & gantry cranes).
- (b) *Assembly/disassembly*.
  - (1) In addition to compliance with §§ 1926.1403 (Assembly/disassembly— selection of manufacturer or employer procedures) and 1926.1406 (Assembly/ disassembly—employer procedures), the employer must also comply with § 1926.1441(b)(2)–(3).
  - (2) *Components and configuration*. The employer must ensure that:
    - (i) The selection of components, and the configuration of the equipment, that affect the capacity or safe operation of the equipment complies with either the:
      - (A) Manufacturer instructions, recommendations, limitations, and specifications. When these documents and information are unavailable, a registered professional engineer familiar with the type of equipment involved must approve, in writing, the selection and configuration of components; or
      - (B) Approved modifications that meet the requirements of § 1926.1434 (Equipment modifications).
    - (ii) *Post-assembly inspection*. Upon completion of assembly, the equipment is inspected to ensure that it is in compliance with paragraph (b)(2)(i) of this section (*see* § 1926.1412(c) for post- assembly inspection requirements).
- (3) *Manufacturer prohibitions*. The employer must comply with applicable manufacturer prohibitions.
- (c) *Operation—procedures*.
  - (1) The employer must comply with all manufacturer procedures applicable to the operational functions of the equipment, including its use with attachments.
  - (2) *Unavailable operation procedures*. The employer must:
    - (i) When the manufacturer’s procedures are unavailable, develop, and ensure compliance with, all procedures necessary for the safe operation of the equipment and attachments.
    - (ii) Ensure that procedures for the operational controls are developed by a qualified person.
    - (iii) Ensure that procedures related to the capacity of the equipment are developed and signed by a registered professional engineer familiar with the equipment.
  - (3) *Accessibility*. The employer must ensure that:
    - (i) The load chart is available to the operator at the control station;
    - (ii) Procedures applicable to the operation of the equipment, recommended operating speeds, special hazard warnings, instructions, and operator’s manual are readily available for use by the operator.
    - (iii) When rated capacities are available at the control station only in electronic form and a failure occurs that makes the rated capacities inaccessible, the operator immediately ceases operations or follows safe shut-down procedures until the rated capacities (in electronic or other form) are available.

(d) *Safety devices and operational aids.*











- (1) The employer must ensure that safety devices and operational aids that are part of the original equipment are maintained in accordance with manufacturer procedures.
  - (2) *Anti two-blocking.* The employer must ensure that equipment covered by this section manufactured more than one year after November 8, 2010 have either an anti two-block device that meets the requirements of § 1926.1416(d)(3), or is designed so that, in the event of a two-block situation, no damage or load failure will occur (for example, by using a power unit that stalls in response to a two-block situation).
- (e) *Operator qualifications.* The employer must train each operator, prior to operating the equipment, on the safe operation of the type of equipment the operator will be using.
- (f) *Signal person qualifications.* The employer must train each signal person in the proper use of signals applicable to the use of the equipment.
- (g) *[Reserved.]*
- (h) *Inspections.* The employer must ensure that equipment is inspected in accordance with manufacturer procedures.
- (i) *[Reserved.]*
- (j) *Hoisting personnel.* The employer must ensure that equipment covered by this section is not used to hoist personnel.
- (k) *Design.* The employer must ensure that the equipment is designed by a qualified engineer.

**§ 1926.1442 Severability.**

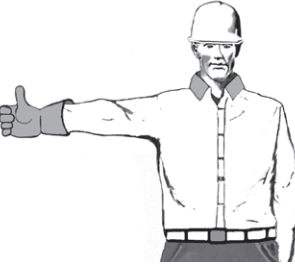
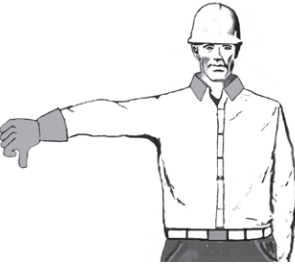
Should a court of competent jurisdiction hold any provision(s) of subpart CC to be invalid, such action shall not affect any other provision of the subpart.

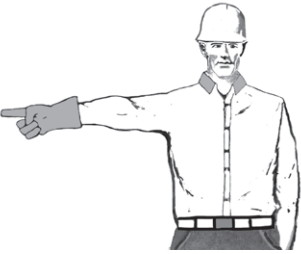
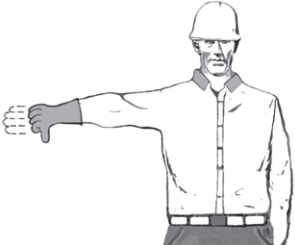

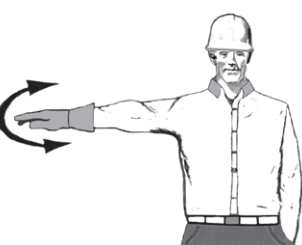
## Appendix A to Subpart CC of Part 1926—Standard Hand Signals

 <p><b>HOIST</b> With upper arm extended to the side, forearm and index finger pointing straight up, hand and finger make small circles.</p>	 <p><b>LOWER</b> With arm and index finger pointing down, hand and finger make small circles.</p>	 <p><b>USE MAIN HOIST</b> A hand taps on top of the head. Then regular signal is given to indicate desired action.</p>	 <p><b>USE AUXILIARY HOIST (Whipline)</b> With arm bent at elbow and forearm vertical, elbow is tapped with other hand. Then regular signal is used to indicate desired action.</p>
 <p><b>BOOM UP</b> With arm extended horizontally to the side, thumb points up with other fingers closed.</p>	 <p><b>BOOM DOWN</b> With arm extended horizontally to the side, thumb points down with other fingers closed.</p>	 <p><b>MOVE SLOWLY</b> A hand is placed in front of the hand that is giving the action signal. (Hoist slowly shown in example.)</p>	 <p><b>SWING</b> With arm extended horizontally, index finger points in direction that boom is to swing.</p>
 <p><b>BOOM DOWN &amp; RAISE THE LOAD</b> With arm extended horizontally to the side and thumb pointing down, fingers open and close while load movement is desired.</p>	 <p><b>BOOM UP &amp; LOWER THE LOAD</b> With arm extended horizontally to the side and thumb pointing up, fingers open and close while load movement is desired.</p>	 <p><b>STOP</b> With arm extended horizontally to the side, palm down, arm is swung back and forth.</p>	 <p><b>DOG EVERYTHING</b> Hands held together at waist level.</p>

© 2013 National Commission for the Certification of Crane Operators. All rights reserved.



**TRAVEL/TOWER TRAVEL**

With all fingers pointing up, arm is extended horizontally out and back to make a pushing motion in the direction of travel.

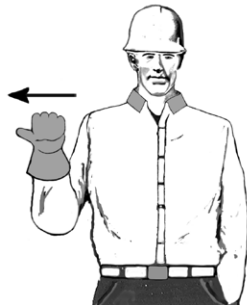

**TROLLEY TRAVEL**

With palm up, fingers closed, and thumb pointing in direction of motion, hand is jerked in direction trolley is to travel.



**CRAWLER CRANE TRAVEL, BOTH TRACKS**

Use both fists in front of body, making a circular motion about each other indicating direction of travel, forward or backward.



**CRAWLER CRANE TRAVEL, ONE TRACK**

Indicate track to be locked by raising fist on that side. Rotate other fist in front of body in direction that other track is to travel.



**TELESCOPE OUT**

With hands to the front at waist level, thumbs point outward with other fingers closed.



**TELESCOPE IN**

With hands to the front at waist level, thumbs point at each other with other fingers closed.



**TELESCOPE OUT (One-handed signal)**

One fist in front of chest with thumb tapping chest.



**TELESCOPE IN (One-handed signal)**

One fist in front of chest, thumb pointing outward and heel of fist tapping chest.

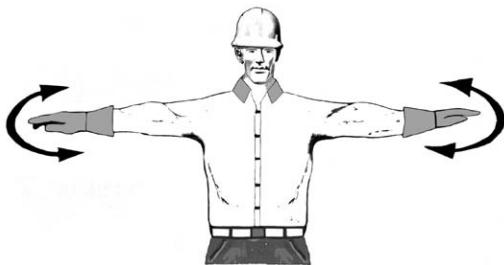

**EMERGENCY STOP**

With both arms extended horizontally to the side, palms down, arms are swung back and forth.

Hand signal descriptions compiled from OSHA and ASME B30 standards.



**CHAPTER 7:**  
**Rigger Reference Booklet**

# **RIGGER REFERENCE BOOKLET**

This Reference Booklet has been produced and adapted from various manufacturers' data and is for use in NCCCO written examinations.

*This Reference Booklet is not to be used for any other purpose.*

© Copyright 2013 National Commission for the Certification of Crane Operators (NCCCO). All rights reserved. This document may not be reproduced in whole or in part without the express written permission of the manufacturer and the consent of NCCCO.

## **HOLD HARMLESS/RELEASE/DISCLAIMER AGREEMENT**

The reading and/or using person or entities using this publication for and in consideration of the assistance, cooperation, and information given by the National Commission for the Certification of Crane Operators (NCCCO) in this publication, *Rigger Reference Booklet*, the receipt of which is acknowledged, does hereby and for all future time have released, hold harmless from any liability, and forever discharged for itself, its administrators and assigns the said NCCCO from all and any manner of action or demands whatsoever in law, in admiralty, or in equity, which against the said NCCCO anyone ever had, now have, or which shall be later claimed. This agreement relates specifically to any cause of action arising out of the publication, information provided, subsequent conduct, and any use of the information provided in this publication and related uses or demonstrations of skills, methods, and techniques cited in the publication. This mutually

beneficial release and hold harmless agreement may not be changed orally and exists in perpetuity. NCCCO generally and specifically disclaims any warranty, merchantability of intended or unintended use, or liability for use of the in the information. This publication is issued solely as a public service to improve the lifting industry and promote public safety.

Copyright 2013 by National Commission for the Certification of Crane Operators. All rights reserved. No part of this book may be reproduced or transmitted in any form or by any means, electronic or mechanical, including photocopying, recording, or by any information storage and retrieval system, without prior written permission from the publisher. For information, contact the publisher, National Commission for the Certification of Crane Operators.

## General Data

1

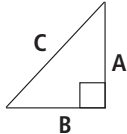
$A^2 + B^2 = C^2$ $C^2 - A^2 = B^2$ $C^2 - B^2 = A^2$ Area of a triangle = $\frac{1}{2} \times A \times B$		<ul style="list-style-type: none"> <li>• d = diameter</li> <li>• L = length</li> <li>• W = width</li> <li>• Circumference = <math>\pi \times d</math></li> <li>• Volume of rectangular prism = <math>L \times W \times H</math></li> </ul>	<ul style="list-style-type: none"> <li>• r = radius</li> <li>• H = height</li> <li>• <math>\pi</math> or Pi = 3.14</li> <li>• Area of a circle = <math>\pi \times r^2</math></li> <li>• Area of a square = <math>L \times W</math></li> </ul>
Wire Rope Sling D/d Ratio Strength Efficiencies 25:1 = 100 20:1 = .92 15:1 = .88 10:1 = .86 4:1 = .75 2:1 = .65 1:1 = .50	1 yard = 3 ft. = 36 in. = .91 meter 1 meter = 1.09 yd. = 3.28 ft. = 39.37 in. 1 ton (short) = .891 long ton = .91 metric ton = 2,000 lbs. = 907 kg 1 ton (metric) = 1.1 short ton = .98 long ton = 2,204 lb. = 1,000 kg 1 pound = .45 kg 1 kg = 1,000 grams = 2.2 lb. 1 gallon (U.S. liq.) = 4 qt. = 3.8 liters 1 liter = .264 gallon (U.S.) = 1.06 qt. 1 KIP = 1,000 lb.		

## Calculating Load Weights

2

Materials and Liquids - Pounds / cu. ft.		Pounds / sq. ft.		Pounds / gallon	
Aluminum	168	Iron Casting	460	Steel plate	
Asbestos	153	Lead	710	• 1/8 inch	5
Asphalt	80	Lumber-Fir	40	• 1/4 inch	10
Brass	521	Lumber-Oak	62	• 1/2 inch	20
Brick	120	Lumber - RR Ties	50	• 1 inch	40
Bronze	500	Oil, Motor	58	Aluminum plate	
Coal	56	Paper	60	• 1/8 inch	1.75
Concrete, Reinforced	150	Portland Cement	94	• 1/4 inch	3.50
Crushed Rock	95	River Sand	120	Lumber	
Diesel	53	Rubber	94	• 3/4 inch Fir	2.5
Dry Earth, Loose	74	Steel	480	• 3/4 inch Oak	4.0
Gasoline	45	Water	62		
Glass	160	Zinc	437		

Gasoline	6.0
Diesel	7.0
Water	8.3

  

7.5 gallons of liquid to a cubic foot
27 cubic feet to a cubic yard

## Load Factors & Weight Distribution

3

$$\text{Sling Tension} = \frac{\text{Sling Length (L)}}{\text{Sling Height (H)}} \times \text{share of load wt.}$$

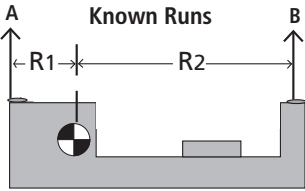
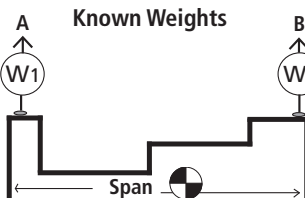
 <p>Known Runs</p>	<table border="1"> <thead> <tr> <th>Share of Load Wt. @ A</th> <th>Share of Load Wt. @ B</th> <th>Legend</th> </tr> </thead> <tbody> <tr> <td><math>R_1 + R_2 = TS</math></td> <td><math>R_1 + R_2 = TS</math></td> <td><math>R_1 = \text{Run, Side 1}</math></td> </tr> <tr> <td><math>\frac{R_2}{TS} = P</math></td> <td><math>\frac{R_1}{TS} = P</math></td> <td><math>R_2 = \text{Run, Side 2}</math></td> </tr> <tr> <td><math>P \times W = \text{Share of Load Wt. @ A}</math></td> <td><math>P \times W = \text{Share of Load Wt. @ B}</math></td> <td><math>TS = \text{Total Span}</math></td> </tr> <tr> <td></td> <td></td> <td><math>P = \text{Percentage}</math></td> </tr> <tr> <td></td> <td></td> <td><math>W = \text{Weight of Load}</math></td> </tr> </tbody> </table>	Share of Load Wt. @ A	Share of Load Wt. @ B	Legend	$R_1 + R_2 = TS$	$R_1 + R_2 = TS$	$R_1 = \text{Run, Side 1}$	$\frac{R_2}{TS} = P$	$\frac{R_1}{TS} = P$	$R_2 = \text{Run, Side 2}$	$P \times W = \text{Share of Load Wt. @ A}$	$P \times W = \text{Share of Load Wt. @ B}$	$TS = \text{Total Span}$			$P = \text{Percentage}$			$W = \text{Weight of Load}$
Share of Load Wt. @ A	Share of Load Wt. @ B	Legend																	
$R_1 + R_2 = TS$	$R_1 + R_2 = TS$	$R_1 = \text{Run, Side 1}$																	
$\frac{R_2}{TS} = P$	$\frac{R_1}{TS} = P$	$R_2 = \text{Run, Side 2}$																	
$P \times W = \text{Share of Load Wt. @ A}$	$P \times W = \text{Share of Load Wt. @ B}$	$TS = \text{Total Span}$																	
		$P = \text{Percentage}$																	
		$W = \text{Weight of Load}$																	
 <p>Known Weights</p>	<table border="1"> <thead> <tr> <th>CG In Feet From A</th> <th>CG In Feet From B</th> <th>Legend</th> </tr> </thead> <tbody> <tr> <td><math>W_1 + W_2 = TW</math></td> <td><math>W_1 + W_2 = TW</math></td> <td><math>W_1 = \text{Weight at A}</math></td> </tr> <tr> <td><math>\frac{W_2}{TW} = P</math></td> <td><math>\frac{W_1}{TW} = P</math></td> <td><math>W_2 = \text{Weight at B}</math></td> </tr> <tr> <td><math>P \times S = \text{CG in ft. from A}</math></td> <td><math>P \times S = \text{CG in ft. from B}</math></td> <td><math>TW = \text{Total Weight}</math></td> </tr> <tr> <td></td> <td></td> <td><math>P = \text{Percentage}</math></td> </tr> <tr> <td></td> <td></td> <td><math>S = \text{Span}</math></td> </tr> </tbody> </table>	CG In Feet From A	CG In Feet From B	Legend	$W_1 + W_2 = TW$	$W_1 + W_2 = TW$	$W_1 = \text{Weight at A}$	$\frac{W_2}{TW} = P$	$\frac{W_1}{TW} = P$	$W_2 = \text{Weight at B}$	$P \times S = \text{CG in ft. from A}$	$P \times S = \text{CG in ft. from B}$	$TW = \text{Total Weight}$			$P = \text{Percentage}$			$S = \text{Span}$
CG In Feet From A	CG In Feet From B	Legend																	
$W_1 + W_2 = TW$	$W_1 + W_2 = TW$	$W_1 = \text{Weight at A}$																	
$\frac{W_2}{TW} = P$	$\frac{W_1}{TW} = P$	$W_2 = \text{Weight at B}$																	
$P \times S = \text{CG in ft. from A}$	$P \times S = \text{CG in ft. from B}$	$TW = \text{Total Weight}$																	
		$P = \text{Percentage}$																	
		$S = \text{Span}$																	

## Level & Incline Planes

4

Legend	Formulas
W = Weight of load	Level: $F = CF \times W$
CF = Coefficient of Friction	
F = Force required to move load	Uphill: $F = (CF \times R/L \times W) + (W \times H/L)$
H = Height in feet	Downhill: $F = (CF \times R/L \times W) - (W \times H/L)$
R = Run, horizontal distance in feet	
L = Length of ramp in feet	

## Coefficients of Friction [For Estimation Only]

Concrete on concrete	.65	Wood on metal	.30	Steel on steel	.10
Metal on concrete	.60	Cast iron on steel	.25	Load on wheels	.05
Wood on wood	.50	Continuous lubricated surface	.15	Load on ice	.01
Wood on concrete	.45			Load on air	.002

## Level Pick Points

5

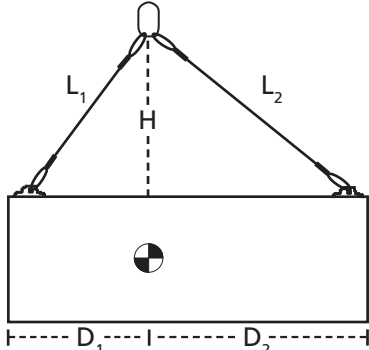
Legend	
W = Load Weight	
D <sub>1</sub> = Distance of Side 1	
D <sub>2</sub> = Distance of Side 2	
L <sub>1</sub> = Sling Length, Side 1	
L <sub>2</sub> = Sling Length, Side 2	
H = Vertical Height	
TL <sub>1</sub> = Tension, Length 1	
TL <sub>2</sub> = Tension, Length 2	

$$TL_1 = \frac{L_1 \times W \times D_2}{H \times (D_1 + D_2)}$$

$$TL_2 = \frac{L_2 \times W \times D_1}{H \times (D_1 + D_2)}$$

## Off-level Pick Points

6

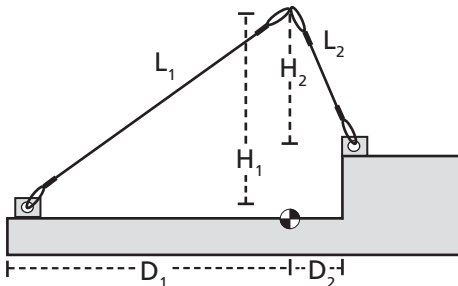
Legend	
W = Load Weight	
D <sub>1</sub> = Distance of Side 1	
D <sub>2</sub> = Distance of Side 2	
L <sub>1</sub> = Sling Length, Side 1	
L <sub>2</sub> = Sling Length, Side 2	
H <sub>1</sub> = Vertical Height, Side 1	
H <sub>2</sub> = Vertical Height, Side 2	
TL <sub>1</sub> = Tension, Length 1	
TL <sub>2</sub> = Tension, Length 2	

$$TL_1 = \frac{W \times D_2 \times L_1}{(D_2 \times H_1) + (D_1 \times H_2)}$$

$$TL_2 = \frac{W \times D_1 \times L_2}{(D_2 \times H_1) + (D_1 \times H_2)}$$

## Block & Fairlead Loading

7

Full Included Angle	Block Factor
180	0.00
170	0.17
160	0.35
150	0.52
140	0.68
130	0.84
120	1.00
110	1.15
100	1.29
90	1.41
80	1.53
70	1.64
60	1.73
50	1.81
40	1.87
30	1.93
20	1.97
10	1.99
0	2.00

### Example

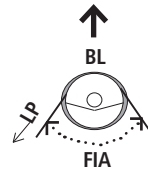

BL = Block Load  
 BF = Block Factor  
 LP = Line Pull  
 FIA = Full Included Angle

**Formula**  
 BL = BF × LP

## Wire Rope EIPS/IWRC Sling Capacities (lb.)



Mechanical Splice

8

Size in inches						
1/4	1,300	960	2,600	2,200	1,820	1,300
5/16	2,000	1,480	4,000	3,400	2,800	2,000
3/8	2,800	2,200	5,600	5,000	4,000	2,800
7/16	3,800	2,800	7,600	6,800	5,400	3,800
1/2	5,000	3,800	10,000	8,800	7,200	5,000
9/16	6,400	4,800	12,800	11,000	9,000	6,400
5/8	7,800	5,800	15,600	13,600	11,000	7,800
3/4	11,200	8,200	22,400	19,400	15,800	11,200
7/8	15,200	11,200	30,400	26,000	22,000	15,200
1	19,600	14,400	39,200	34,000	28,000	19,600
1-1/8	24,000	18,000	48,000	42,000	34,000	24,000
1-1/4	30,000	22,500	60,000	52,000	42,000	30,000

### 3-Part Braided Wire Rope Sling Capacities (tons)



9

Finished Diameter (inches)	Composed of 3 parts of EIP Rope (inches)				Weight Per Ft. Approx. (pounds)
1/2	1/4	1.7	1.3	3.4	.44
5/8	5/16	2.6	1.9	5.2	.68
3/4	3/8	3.6	2.7	7.2	.99
7/8	7/16	4.9	3.7	9.8	1.33
1	1/2	6.4	4.8	12.8	1.75
1-1/8	9/16	8.0	6.0	16.0	2.24
1-3/4	7/8	19.0	14.3	36.0	5.40
2-1/4	1-1/8	31.2	23.4	62.4	8.90
2-3/4	1-3/8	46.0	34.5	92.0	13.30
3-1/4	1-5/8	63.4	47.6	126.8	18.50
4	2	95.0	71.2	190.0	28.00
4-1/2	2-1/4	118.0	88.5	236.0	35.60
5	2-1/2	145.0	109.0	290.0	44.00

Basket-rated capacities based on D/d ratio of five times the wire rope's finished diameter.

### 9-Part Braided Wire Rope Sling Capacities (tons)

10







Finished Diameter (inches)	Composed of 9 parts of EIP Rope (inches)			
1/2	1/8	1.4	1.0	2.8
5/8	5/32	2.0	1.5	4.0
3/4	3/16	3.0	2.2	6.0
7/8	7/32	4.0	3.0	8.0
1	1/4	4.8	3.6	9.6
1-1/2	3/8	10.5	7.8	21.0
2	1/2	19.1	14.3	38.2
2-1/2	5/8	29.6	22.2	59.2
3	3/4	42.3	31.7	84.6
3-1/2	7/8	57.3	42.9	114.6
4	1	74.4	55.8	148.4
4-1/2	1-1/8	93.6	60.2	187.2

Basket-rated capacities based on D/d ratio of five times the wire rope's finished diameter.



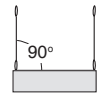

## Synthetic Sling Capacities (lbs.)

(11)

	Size or Code						
Web Eye / Eye	1-9-1	1,600	1,280	3,200	2,770	2,260	1,600
	1-9-2	3,200	2,560	6,400	5,540	4,452	3,200
	1-9-3	4,800	3,840	9,600	8,320	6,780	4,800
	1-9-4	6,400	5,120	12,800	11,090	9,040	6,400
	2-9-3	8,880	7,100	17,760	15,390	12,540	8,880
	2-9-4	11,520	9,210	23,040	19,960	16,270	11,520
Polyester Round	1	2,600	2,100	5,200	4,500	3,600	2,600
	2	5,300	4,200	10,600	9,100	7,500	5,300
	3	8,400	6,700	16,800	14,500	11,800	8,400
	4	10,600	8,500	21,200	18,300	14,900	10,600
	5	13,200	10,600	26,400	22,800	18,600	13,200
	6	16,800	13,400	33,600	29,100	23,700	16,800

## High Capacity Round Sling Capacities (lbs.)\*

(12)

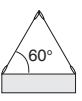
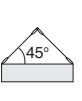

Dual-Path Model						Approx. Body Width (inches)
DP 1000	10,000	8,000	20,000	17,320	14,140	3
DP 1500	15,000	12,000	30,000	25,980	21,210	3
DP 2000	20,000	16,000	40,000	34,640	28,280	3
DP 2500	25,000	20,000	50,000	43,300	35,350	3
DP 3000	30,000	24,000	60,000	51,960	42,420	4
DP 4000	40,000	32,000	80,000	69,280	56,560	4
DP 5000	50,000	40,000	100,000	86,600	70,700	5
DP 6000	60,000	48,000	120,000	103,920	84,840	5
DP 7000	70,000	56,000	140,000	121,240	98,980	5
DP 8500	85,000	68,000	170,000	147,220	120,190	6
DP 10000	100,000	80,000	200,000	173,200	141,400	6
DP 12500	125,000	100,000	250,000	216,500	176,750	8
DP 15000	150,000	120,000	300,000	259,800	212,100	8
DP 17500	175,000	140,000	350,000	303,100	247,450	10
DP 20000	200,000	160,000	400,000	346,400	282,800	10
DP 25000	250,000	200,000	500,000	433,000	353,500	10
DP 27500	275,000	220,000	550,000	476,300	388,850	12
DP 30000	300,000	240,000	600,000	519,600	424,200	12
DP 40000	400,000	320,000	800,000	692,800	565,600	14
DP 50000	500,000	400,000	1,000,000	866,000	707,000	16

\*Capacities shown include both paths and are for one complete sling; sling ratings based on fittings of equal or greater capacity.

# Alloy Chain Sling Capacities (lbs.)

13

## Grade 80

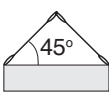
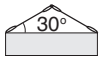
Size in inches	Single Leg		Two Leg Slings			Three & Four Leg Slings	
						60°	45°
9/32	3,500	2,800	6,100	4,900	3,500	9,150	7,400
3/8	7,100	5,700	12,300	10,000	7,100	18,400	15,100
1/2	12,000	9,600	20,800	17,000	12,000	31,200	25,500
5/8	18,100	14,500	31,300	25,600	18,100	47,000	38,400
3/4	28,300	22,600	49,000	40,000	28,300	73,500	60,000
7/8	34,200	27,400	59,200	48,400	34,200	88,900	72,500
1	47,700	38,200	82,600	67,400	47,700	123,900	101,200
1-1/4	72,300	57,800	125,200	102,200	72,300	187,800	153,400

## Grade 100

9/32	4,300	3,500	7,400	6,100	4,300	11,200	9,100
3/8	8,800	7,100	15,200	12,400	8,800	22,900	18,700
1/2	15,000	12,000	26,000	21,200	15,000	39,000	31,800
5/8	22,600	18,100	39,100	32,000	22,600	58,700	47,900
3/4	35,300	28,300	61,100	49,900	35,300	91,700	74,900
7/8	42,700	34,200	74,000	60,400	42,700	110,900	90,600

# Rigging Hardware Capacities (lbs.)

14

Size in inches	Shoulder Eye Bolt		Turnbuckle Eye or Jaw	Shackle SP Anchor	Wire Rope Clip			Swivel Hoist Rings WLL (lbs.)	Alloy Master Links WLL (lbs.)
	In Line	45 deg.			Min. # clips	Turnback (inches)	Torque (ft. lbs.)		
1/4	500	125	500	1,000	2	4.75	15	-----	-----
5/16	800	200	800	1,500	2	5.25	30	800	-----
3/8	1,200	300	1,200	2,000	2	6.50	45	1,000	-----
7/16	-----	-----	-----	3,000	2	7.00	65	-----	-----
1/2	2,200	550	2,200	4,000	3	11.50	65	2,500	7,400
9/16	-----	-----	-----	-----	3	12.00	95	-----	-----
5/8	3,500	875	3,500	6,500	3	12.00	95	4,000	9,000
3/4	5,200	1,300	5,200	9,500	4	18.00	130	5,000	12,300
7/8	7,200	1,800	7,200	13,000	4	19.00	225	8,000	15,200
1	10,000	2,500	10,000	17,000	5	26.00	225	10,000	26,000
1-1/8	-----	-----	-----	19,000	6	34.00	225	-----	-----
1-1/4	15,200	3,800	15,200	24,000	7	44.00	360	15,000	39,100
1-1/2	-----	-----	-----	-----	-----	-----	-----	-----	61,100
2	-----	-----	-----	-----	-----	-----	-----	-----	102,600
2-1/2	-----	-----	-----	-----	-----	-----	-----	-----	160,000
3	-----	-----	-----	-----	-----	-----	-----	-----	228,000
3-1/2	-----	-----	-----	-----	-----	-----	-----	-----	279,000
4	-----	-----	-----	-----	-----	-----	-----	-----	373,000

## Synthetic Sling Shackle

15

Round Sling Size (No.)	Web Slings*		Working Load Limit (Tons)
	Webbing Width (in.)	Eye Width (in.)	
1	2	2	3-1/4
2	2	2	3-1/4
3	3	1.5	4-1/2
4	4	2	6-1/4
5	6	3	8-1/2
6	6	3	8-1/2

\* NOTE: Designed for use with Type III, (Eye & Eye), Class 7, 2 Ply web slings. For 3" and larger webbing width, tapered eye is required.

## Wide Body Shackles

16

Working Load Limit (Tons)	Weight Each (lbs.)	Dimensions in Inches			"B" is spread between shackle ears "D" is shackle pin diameter  Effective Body Diameter is the diameter to use when calculating D/d ratio for sling:  D = effective body diameter d = sling diameter
		B +/- .02	D +/- .02	Effective Body Diameter	
7	4.0	1.25	0.88	2.1	
12.5	8.8	1.69	1.13	2.4	
18	14.9	2.03	1.38	2.8	
30	26.5	2.37	1.63	4.1	
40	35.0	2.88	2.00	3.6	
55	68.0	3.25	2.25	4.3	
75	99.0	4.13	2.75	5.9	
125	161	5.12	3.15	6.8	
200	370	5.91	4.12	8.9	
300	847	7.38	5.25	11.8	
400	1130	8.66	6.30	14.3	

This page intentionally left blank

## IMPORTANT CONTACT INFORMATION



### **NATIONAL COMMISSION FOR THE CERTIFICATION OF CRANE OPERATORS**

2750 Prosperity Avenue, Suite 505  
Fairfax, VA 22031-4312

Phone: 703-560-2391

Fax: 703-560-2392

E-mail: [info@nccco.org](mailto:info@nccco.org)



### **INTERNATIONAL ASSESSMENT INSTITUTE**

Attention: NCCCO Testing  
600 Cleveland Street, Suite 900  
Clearwater, Florida 33755

Phone: 727-449-8525

Fax: 727-461-2746



**NATIONAL COMMISSION FOR THE  
CERTIFICATION OF CRANE OPERATORS**

2750 Prosperity Avenue, Suite 505  
Fairfax, VA 22031-4312

Phone: 703-560-2391

Fax: 703-560-2392

[info@nccco.org](mailto:info@nccco.org)

[www.nccco.org](http://www.nccco.org)