



## Refinery Rigging

(Field Guide)

## Los Angeles Refinery's Three Basic Principles

### We will...

Do it **SAFELY** or not at all.

There is **ALWAYS** time to do it right.

We operate at the **PLEASURE** of the Community.

### The Ten Tenets

1. **NEVER** operate equipment or tanks outside of design or environmental limits.
2. **ALWAYS** move to a safe, controlled condition and seek assistance when a situation is not understood.
3. **ALWAYS** operate with safety and environmental protection devices enabled.
4. **ALWAYS** follow all safety/ environmental work practices/ procedures and act to stop unsafe conditions and actions.
5. **ALWAYS** produce a product that meets or exceeds our customer's requirements.
6. **NEVER** contaminate or compromise a dedicated system.
7. **ALWAYS** report environmental/ safety compliance information accurately and on time.
8. **ALWAYS** address abnormal conditions and clarify/ understand procedures before proceeding.
9. **ALWAYS** develop and follow written procedures for high risk or unusual situations.
10. **ALWAYS** involve people with expertise and first-hand knowledge in decisions, improvements, and changes that affect procedures and equipment.

## TABLE OF CONTENTS

1	Purpose	2
2	Capacity Reductions	3
3	Rigging Best Practices	15
4	Capacity Charts	19
5	Weight Calculations	22
6	Inspection Criteria	28
7	Signalperson	33
8	Broderson Cranes	37
9	Site Safety	47
10	Knots	53
11	Glossary and References	55

## Purpose

This book is meant as a quick reference field guide and does not replace the requirement for qualified Riggers to be familiar with Standards, Regulations and Policies listed in the References.

The material presented is consistent with standards for Basic Rigging and Flex Rigging training.

Advanced Rigging and Mobile Crane certification concepts are outside the scope of this book.

Core Competencies of a Basic/Flex Rigger (at a minimum):

- Calculate capacity reductions to WLLs of slings, hitches, hardware, rigging configurations.
- Calculate basic load weight, center of gravity, sling tension.
- Inspect slings, hardware and rigging gear.
- Select and attach rigging gear appropriate to the lift.
- Signalperson qualified.
- Understand Gross/Net Load/Capacity as it regards crane operations.
- Identify and mitigate crush/pinch points and other site safety hazards.

## Capacity Reductions: Definitions

**Working Load Limit – WLL** is the Rated Capacity of rigging gear based on the ideal rigging situation and configuration. It is calculated in straight line pulls, never side loading.

Example: the tag on a web sling will show the WLL for a basket hitch, but that will only be true for the ideal configuration, 90°.

**Reduced WLL** is when the WLL must be Reduced because of the rigging situation and configuration.

Example: a basket hitch at a 30° configuration will have its WLL reduced by half. (see page 5). When you decrease the angle the WLL must be adjusted to a reduced level.

**NOTE:** Rigging equipment does not operate at rated capacity safety factor indefinitely. A variety of things can degrade it: corrosion, stress, UV sunlight, damage, etc.

## Capacity Reductions: Basket or 2-leg Vertical Hitch

As Sling Angle is lowered:

1. Load Capacity (WLL) decreases.

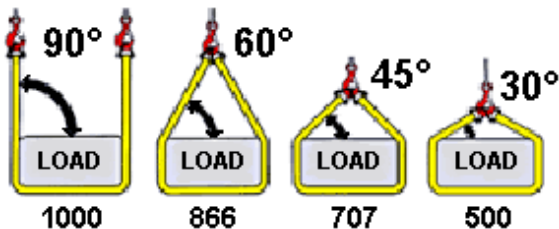

2. Sling Tension increases.

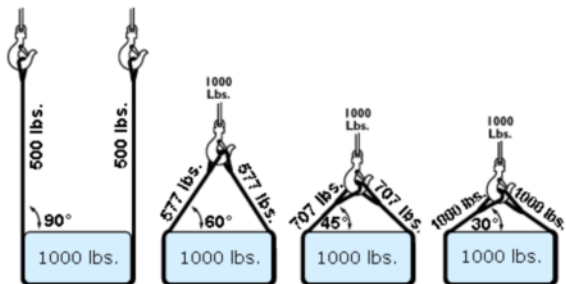

## Capacity Reductions: Basket or 2-leg Vertical Hitch

Calculate Sling Tension.  $(L \times LAF) / 2 = \text{Sling Tension}$ .

Example (2 legs):

1. Determine sling angles. ( $45^\circ$ )
2. Select corresponding Load Angle Factor. (1.414)
3. Multiply Load weight by Load Angle Factor to get total load on sling legs.  
 $(2000 \text{ lbs} \times 1.414 = 2828 \text{ lbs})$
4. Divide total load by number of sling legs.  
 $(2828 \text{ lbs} \div 2 = 1414 \text{ lbs per sling leg})$
5. Select slings from the single vertical leg column within the sling capacity table.

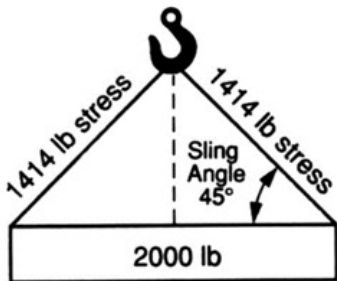

Sling Angle (degrees)	Load Angle Factor
65°	1.104
60°	1.155
55°	1.221
50°	1.305
45°	1.414
40°	1.555
35°	1.742
30°	2.000

- When sling angles are between those listed in chart, use the next lower sling angle and corresponding load angle factor.
- When using 3 or 4 sling legs equal in length, divide the total by 3.
- When the load is not distributed uniformly (equally) on sling legs, the tension on each leg must be calculated individually.

## Capacity Reductions: D/d Ratio - Wire Rope

D/d Ratio, as it applies to wire rope, is the Diameter of the Load or Hardware divided by the diameter of the wire rope.

A fully rated wire rope Basket Hitch must have 90° sling legs, a D/d Ratio of at least 25:1, an even wrap.

D/d RATIO	Wire Rope Sling Strength Efficiencies
25/1	100%
20/1	92%
15/1	88%
10/1	86%
8/1	84%
6/1	80%
4/1	75%
2/1	65%
1/1	50%

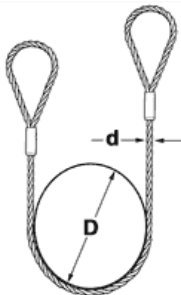

### D/d Ratios smaller than 25:1 will reduce the WLL.

For example: If the shackle or object has 2 times the diameter of the wire rope sling (D/d 2:1) the basket sling capacity will be 65% of WLL. So if a Basket Hitch WLL is 1000 lbs, a 2:1 D/d ratio will reduce it to a 650 lb Reduced WLL.

**WLL x .65 = Reduced WLL**

A D/d ratio of 1:1 will cut WLL in half.

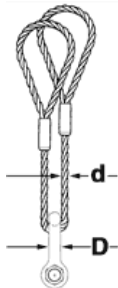



## Capacity Reductions: D/d Ratio (sling eyes)

The eyes of wire rope Eye and Eye slings have the advantage of being like mini-baskets in that the capacities are double that of the body.

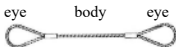

So if the body is rated at 1000 lbs. in a vertical hitch, the eyes will have a 2000 lb capacity.

### D must not be smaller than d.

However, if a shackle of the same diameter is used, D/d ratio of 1:1 is in effect which reduces the eye capacity in half. The eye is reduced to 1000 lbs. to equal the body WLL.

*(This does not apply to thimbled eyes.)*

### D must not be bigger than half the Eye Length.

If the Diameter of the hardware in a wire rope sling eye is too big, it spreads the eye into wide angles against the swaging which reduces WLL in the same manner as basket hitch angle reductions.

*(For web sling eyes, D must not be bigger than one third the Eye Length.)*

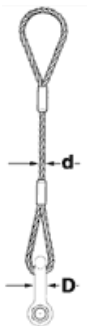

## Capacity Reductions: D/d Ratio-Chain Slings

A Chain Sling D/d ratio must be 6:1 and above to equal the WLL of a Basket Hitch listed on the sling tag.

### Basket Sling Hitch-Rated Capacity Affected by D/d

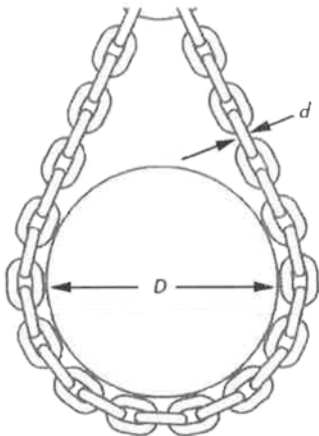

<i>D/d</i>	Rated Capacity, %
Less than 2	Not recommended
2	60
3	70
4	80
5	90
6 and above	100

## Capacity Reductions: Chain Slings

<b>Reduced WLL of Alloy Chain Slings at High Temperatures</b>				
Temp (°F)	Grade 80		Grade 100	
	RWLL while in use at Temp	Permanent RWLL after use at Temp	RWLL while in use at Temp	Permanent RWLL after use at Temp
Below 400°	none	none	none	none
400°	10%	none	15%	none
500°	15%	none	25%	5%
600°	20%	5%	30%	15%
700°	30%	10%	40%	20%
800°	40%	15%	50%	25%
900°	50%	20%	60%	30%
1000°	60%	25%	70%	35%
Over 1000°	note (1)	note (1)	note (1)	note (1)
note (1): Remove from Service				

Do not use Synthetic Slings in temperatures above 180°.

## Capacity Reductions: Choker Hitch

When a Choker Hitch Angle is less than  $120^\circ$ , the choker capacity (WLL) must be adjusted.

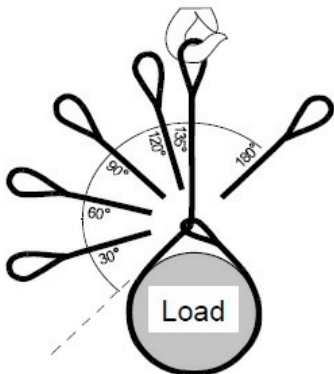

Choker Hitch Angle Reduction Chart	
Choker Hitch Angle (degrees)	Reduction Factor
120 - 180	1.00
105 - 120	.82
90 - 105	.71
60 - 90	.58
0 - 60	.50

## Capacity Reductions: Choker Hitch

Examples: WLL on the Tag for this sling in a Choker hitch is 7.2 tons.



Determine Reduced WLL using the Reduction Factor from the Table.

Example one, **120°**

**WLL x RF = Reduced WLL**

$$7.2 \times 1.00 = 7.2 \text{ tons.}$$

Full choker capacity.

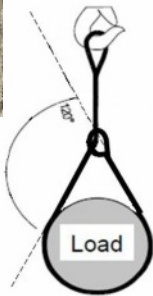

Example two, **30°**

**WLL x RF = Reduced WLL**

$$7.2 \times .50 = 3.6 \text{ tons.}$$

Reduced choker capacity by half.

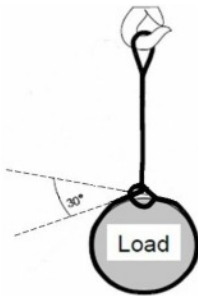

**Tip:** resist the urge to pound down a choke to “grab” the load. Double wrap the choke instead.

## Capacity Reductions: Shackles

Shackles symmetrically loaded with an included angle of 120° can be used to the full WLL.

Do not exceed 120° included angle loading.

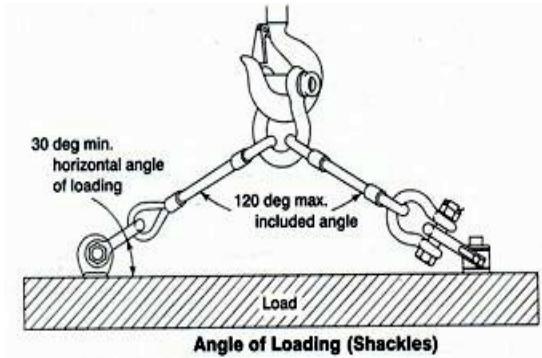

However, Shackles that are single side loaded will have a Reduced WLL (see next page).

Multiply Rated Capacity (WLL) by Reduction Factor to get actual Reduced Working Load Limit.

### **WLL x RF = Reduced WLL**

Examples – a Shackle rated 1000 pounds can lift:

- $1000 \times 1.0 = 1000$  pounds in-line.
- $1000 \times 0.7 = 700$  pounds at 45°.
- $1000 \times 0.5 = 500$  pounds at 90° (half).

## Capacity Reductions: Shackles

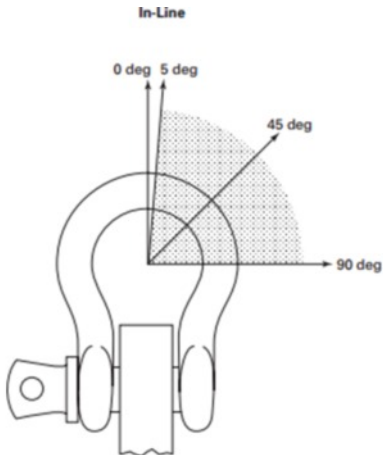

Shackle Reduction Chart	
Side Load Angle (degrees)	Reduction Factor
In-line, 0 - 5	1.00
6 - 45	.70
46 - 90	.50
over 90	Do not rig

For Screw-Pin and Bolt-type shackles only. Do not side load Round-Pin shackles.

## Capacity Reductions: Eyebolts

### Eye Bolt Working Load Limits

- Shoulder Type Only
- Forged Carbon Steel

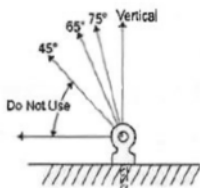

Shank Diameter	Vertical Pull	60° Pull	45° Pull
1/4	650	420	195
5/16	1200	780	360
3/8	1550	1000	465
1/2	2600	1690	780
5/8	5200	3380	1560
3/4	7200	4680	2160
7/8	10,600	6890	3180
1	13,300	8645	3990
1 1/4	21,000	13,600	6300
1 1/2	24,000	15,600	7200

Angle pull in the plane of the eye only.  
Use shims to line up eyebolt.

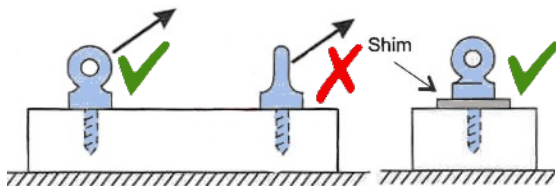



## Rigging Best Practices:

**Included Angle limitations:** when attaching multiple slings to a hook:

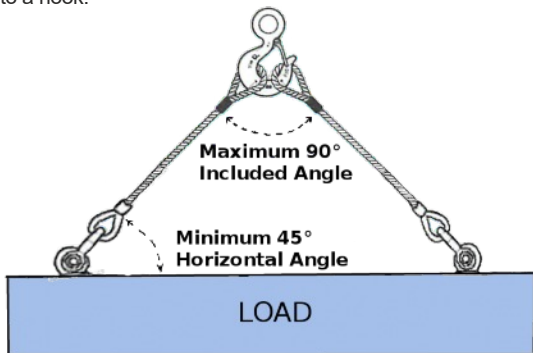

If greater than 90° sling attachment is required, use a shackle, pear link or master link out to 120°.

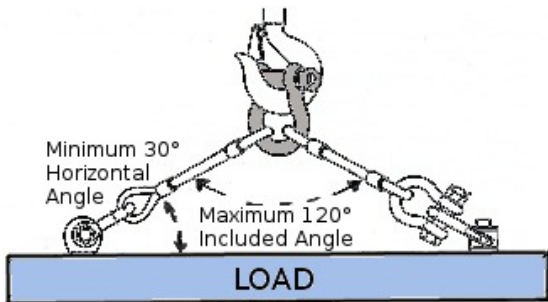

## Rigging Best Practices:



**Side Load**

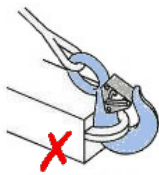

**Back Load**

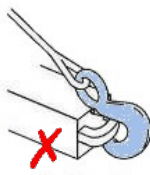

**Tip Load**

Wrong Hook Loading methods.



**Correct**



**Do Not Exceed 45°**

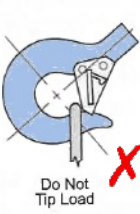

**Do Not Tip Load**

Attaching to a Hook.

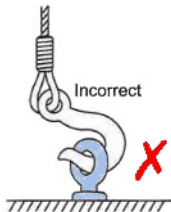

**Incorrect**

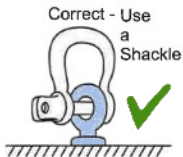

**Correct - Use a Shackle**

Attaching to Eyebolts.

## Rigging Best Practices:

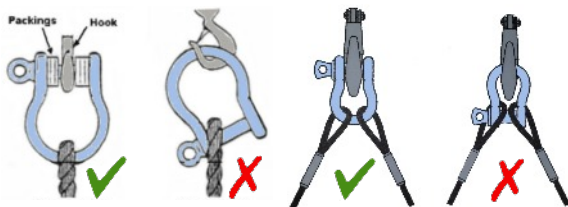

Attaching to Shackles, gather slings in the bow.

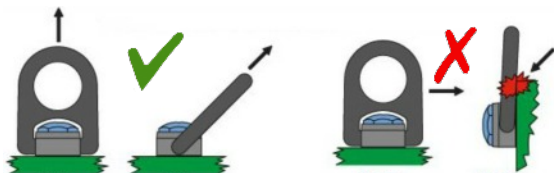

Attaching to Hoist Rings, ensure free rotation.

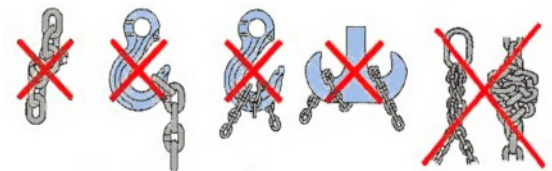

Chain sling no-no's.

## Rigging Best Practices:

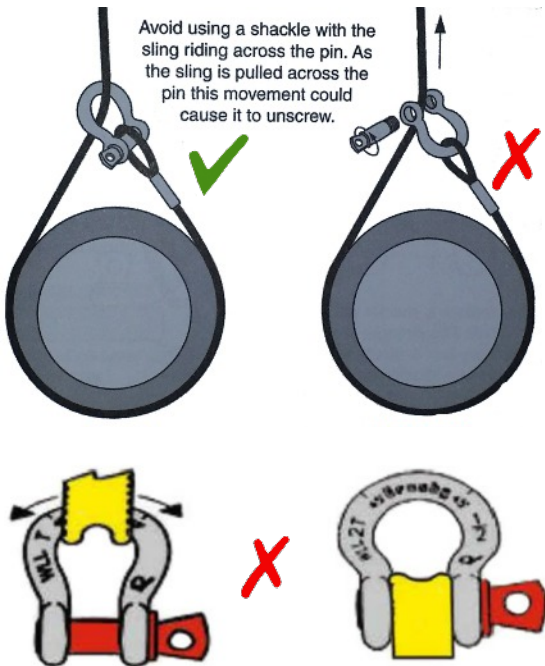

Folding, Bunching or Pinching of synthetic slings will reduce the WLL and should be avoided.

## Capacity Chart: Roundsling (Lift-It)

Roundsling (Lift-It): Sling Capacities							
Stock Number	Vertical 1.0	Choker .8	90° 2-Leg or Basket 2.0	60° 1.73	45° 1.41	Minimum Connection Dia. Choker or Vertical	Minimum Connection Dia. Basket
RS30	2,650	2,120	5,300	4,500	3,600	.50"	.62"
RS50	4,000	3,200	8,000	6,900	5,600	.50"	.62"
RS60	5,300	4,240	10,600	9,100	7,400	.62"	.88"
RS90	8,400	6,720	16,800	14,500	11,800	.75"	1.00"
RS120	10,600	8,500	21,200	18,300	14,900	.87"	1.25"
RS150	13,200	10,560	26,400	22,800	18,600	1.00"	1.38"
RS180	16,800	13,400	33,600	29,000	23,750	1.00"	1.62"
RS240	21,200	17,000	42,400	36,700	29,900	1.38"	1.75"
RS360	31,000	24,800	62,000	53,600	43,800	1.62"	2.00"
RS400	40,000	32,000	80,000	69,280	56,568	2.25"	2.38"
RS600	53,000	43,000	106,000	91,796	74,942	2.40"	2.75"
RS800	66,000	52,800	132,000	114,312	93,324	2.40"	3.00"
RS1000	90,000	72,000	180,000	155,880	127,260	3.00"	3.50"

**Minimum Connection Diameter**, as the above table references, is the minimum diameter a connection device (shackle, ring, hook) must have to avoid WLL reduction.

**Minimum Edge Radii** - unprotected roundslings on corner edges require a minimum radius rounded edge to avoid too much point stress. This can vary from 3/16<sup>th</sup> to 7/8<sup>th</sup> inch depending on WLL.

**Use Softeners and Padding to best avoid corner stress.**

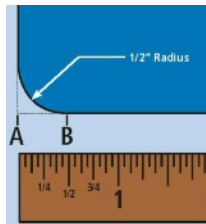

## Capacity Chart: Slings

<b>Wire Rope (EIPS IWRC): Sling Capacities</b>						
Size in inches	 1.0 Vertical	 .75 Choker	 2 - Legs or Basket 90° 2.00	 60 1.73	 45 1.41	 30° 1.00
1/4	1,300	960	2,600	2,200	1,820	1,300
5/16	2,000	1,480	4,000	3,400	2,800	2,000
3/8	2,800	2,200	5,600	5,000	4,000	2,800
7/16	3,800	2,800	7,600	6,800	5,400	3,800
1/2	5,000	3,800	10,000	8,800	7,200	5,000
9/16	6,400	4,800	12,800	11,000	9,000	6,400
5/8	7,800	5,800	15,600	13,600	11,000	7,800
3/4	11,200	8,200	22,400	19,400	15,800	11,200
7/8	15,200	11,200	30,400	26,000	22,000	15,200
1	19,600	14,400	39,200	34,000	28,000	19,600
1-1/8	24,000	18,000	48,000	42,000	34,000	24,000
1-1/4	30,000	22,500	60,000	52,000	42,000	30,000
<b>Chain (G-8): Sling Capacities</b>						
9/32	3,500	2,800	7,000	6,100	4,900	3,500
3/8	7,100	5,680	14,200	12,300	10,000	7,100
1/2	12,000	9,600	24,000	20,800	17,000	12,000
5/8	18,100	14,480	36,200	31,300	25,600	18,100
<b>Web Eye &amp; Eye: Sling Capacities</b>						
1 ply-1	1,600	1,280	3,200	2,770	2,260	1,600
1 ply-2	3,200	2,560	6,400	5,540	4,452	3,200
1 ply-3	4,800	3,840	9,600	8,320	6,780	4,800
1 ply-4	6,400	5,120	12,800	11,090	9,040	6,400
2 ply-3	8,880	7,100	17,760	15,390	12,540	8,880
2 ply-4	11,520	9,210	23,040	19,960	16,270	11,520

## Capacity Chart: Hardware

<b>Hardware Capacities</b>					
Size in inches	Turnbuckle eye or jaw	Master Link	Shackle SPA Anchor	Flat Shackle	Web Eye width
1/4	500		1,000	6,500	1-2
5/16	800		1,500	9,000	3
3/8	1,200		2,000	12,500	4
7/16			3,000	17,000	5
1/2	2,200	4,920	4,000	Swivel Hoist Rings	
9/16				size	WLL
5/8	3,500	6,600	6,500	3/8	1,000
3/4	5,200	10,320	9,500	1/2	2,500
7/8	7,200		13,000	5/8	4,000
1	10,000	24,360	17,000	3/4	5,000
1-1/8			19,000	7/8	8,000
1-1/4	15,200	35,160	24,000	1	10,000

## Weight Calculations: Flange Weight Table

### ANSI B16.5 Forged Flanges

Approx weight in pounds (many smaller sizes not shown)

Class	Nominal Pipe Size	Slip on	Threaded	Socket Weld	Lap Joint	Blind	Weld Neck
150 lb	6	19	19	19	19	27	26
	8	30	30	30	30	47	42
	10	43	43	43	43	70	54
	12	64	64	64	64	123	88
	14	90	90	90	105	140	114
	16	106	98	98	140	180	140
	18	130	130	130	160	220	165
	20	165	165	165	195	285	197
	22	185	185	185	245	355	225
24	220	220	220	275	430	268	
300 lb	6	39	39	39	39	50	45
	8	58	58	58	58	81	69
	10	81	81	81	91	124	100
	12	115	115	115	140	185	142
	14	165	165	165	190	250	206
	16	210	220	190	234	315	250
	18	253	280	250	305	414	320
	20	315	325	315	375	515	400
	22	370	370	370	435	640	465
24	490	490	475	550	800	580	
600 lb	4	37	37	37	36	41	42
	6	80	80	80	78	86	81
	8	115	115	115	112	140	120
	10	177	177	177	195	231	190
	12	215	215	215	240	295	226
	14	259	259	259	290	378	347
	16	366	366	366	400	527	481
	18	476	476	476	469	665	555
	20	612	612	612	604	855	690
	22	590	590	590	670	1000	720
24	876	876	876	866	1250	977	



## Weight Calculations: Flange Weight Table

### ANSI B16.5 Forged Flanges

Approx weight in pounds (many smaller sizes not shown)

Class	Nominal Pipe Size	Slip on	Thread ed	Socket Weld	Lap Joint	Blind	Weld Neck
900 lb	2	22	22	22	21	25	24
	3	36	36	36	29	35	36
	4	53	53	53	51	54	53
	6	110	110	110	105	115	110
	8	172	172	172	190	200	187
	10	245	245	245	277	290	268
	12	326	326	326	371	415	372
	14	400	400	400	415	520	562
	16	459	459	459	488	619	685
	18	647	647	647	670	880	924
	20	792	792	792	868	1107	1164
24	1480	1480	1480	1659	2099	2107	
1500 lb	2	25	25	25	25	25	25
	3	48	48	48	47	48	48
	4	73	73	73	75	73	73
	6	165	165	165	170	160	165
	8	260	260	260	286	302	275
	10	436	436	436	485	510	455
	12	667	667	667	749	775	690
	14	940	940	940	890	975	940
	16	1250	1250	1250	1250	1300	1250
	18	1625	1625	1625	1475	1750	1625
	20	2050	2050	2050	1775	2225	2050
24	2825	2825	2825	2825	3625	3325	
2500 lb	2		38		37	39	42
	3		83		80	86	94
	4		127		122	133	146
	6		323		314	345	378
	8		485		471	533	576
	10		925		897	1025	1068
	12		1300		1262	1464	1608

## Weight Calculations: Pipe Weight Table

<b>Pipe Chart - Steel Weight per Foot in Pounds</b>										
PIPE SIZE	PIPE SCHEDULES									
	10	20	30	40	60	80	100	120	140	160
2	2.6			3.6		5				7.5
2 1/2	3.5			5.8		7.7				10
3	4			7.5		10.2				14
3 1/2	5			9		12.5				
4	5.6			11		15		19		22
5	8			15		21		27		33
6	9			19		29		36		43
8	13	22	24.7	28	36	43	51	61	68	75
10	19	28	34	40	55	64	77	82	104	115
12	24	33	44	53	73	88	107	125	137	160
14	37	45	55	63	85	106	131	151	170	189
16	42	52	63	83	107	137	165	192	224	245
18	47	59	82	105	138	171	208	244	274	308
20	53	78	104	123	166	209	256	296	341	379
24	63	96	141	171	238	296	367	429	483	542
26	86	136								
28	92	147	183							
30	99	157	196							
32	106	168	209	230						
34	112	179	223	245						
36	119		236	282						

## Weight Calculations: Material Weight Tables

Pounds per cubic foot			
Aluminum	165	Iron Casting	460
Asphalt	80	Lead	710
Brick	126	Lumber - Fir	34
Coal	56	Lumber - Oak	62
Concrete, Reinf.	150	Lumber - RR Ties	50
Copper	560	Oil, Motor	58
Crushed Rock	95	Paper	60
Diesel	52	Portland Cement	94
Dry Earth, loose	74	Rubber	94
Gasoline	42	Steel	490
Glass	160	Water	62

Pounds per square foot			
Steel Plate		Aluminum Plate	
1/8"	5	1/8"	1.8
1/4"	10	1/4"	3.5
1/2"	20	Lumber	
1"	40	3/4" Fir	2
		3/4" Oak	4

Pounds per Gallon	
Gas	6
Diesel	7
Water	8.3

## Weight Calculations: Formulas

Circumference of a Circle =  $\pi$  x D.

Area of a Triangle = (L x W) ÷ 2.

Area of a Square or Rectangle = L x W.

Area of a Circle =  $\pi r^2$ .

Volume of a Cube = L x W x H.

Volume of a Cylinder =  $\pi r^2$  x L  
(pipe, tower, tank).

Pythagorean Theorem:  $a^2 + b^2 = c^2$ .

$$\text{So, } a = \sqrt{c^2 - b^2}$$

$$b = \sqrt{c^2 - a^2}$$

$$c = \sqrt{a^2 + b^2}$$

L = Length

W = Width

H = Height

r = Radius

D = Diameter

$\pi$  = 3.1416

1 gal = .134 cf

1 cf = 7.48 gal

1 in = .0833 ft

1 si = .00694 sf

1 sf = 144 si

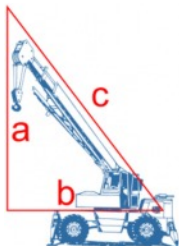
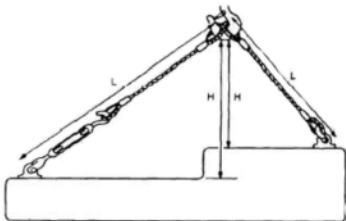

## Weight Calculations: Example

Calculate the weight of a Tank using the Tables & Formulas.

Diameter 10 ft, height 15 feet, steel ½ in thick.

1. Calculate the Area and Weight of the top and bottom.

Top weight = Area of a Circle x the load weight of Steel per square foot.

$$= \pi \times r \times r \times \text{Steel weight}$$

$$= 3.1416 \times 5\text{ft} \times 5\text{ft} \times 20 \text{ lbs/sf} = 1,571 \text{ lbs.}$$

2. Bottom = same as Top = 1,571 lbs.

3. Calculate the Area and Weight of the Body using Circumference to unravel the cylinder into a steel sheet.

Body weight = the circumference of the cylinder x the height x the load weight of Steel per square foot.

$$= \pi \times D \times H \times \text{Steel weight}$$

$$= 3.1416 \times 10\text{ft} \times 15\text{ft} \times 20 \text{ lbs/sf} = 9,425 \text{ lbs.}$$

4. Total weight = 1,571 lbs. + 1,571 lbs. + 9,425 lbs.  
= 12,567 lbs.



# Inspection: Web Sling

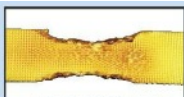

ACID OR CAUSTIC BURNS



CUT



EDGE CUT



MELTING OR CHARRING



ABRASIONS



PUNCTURE



WELD SPATTER

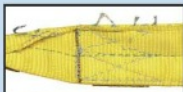

BROKEN OR WORN STITCHES



DAMAGED EYE



EMBEDDED MATERIALS



TENSILE BREAK



MISSING OR ILLEGIBLE TAG

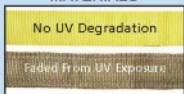

UV DEGRADATION



RED CORE YARN



KNOT



CRUSHED WEBBING



SNAG



DAMAGED HARDWARE

# Inspection: Round Sling



ACID OR CAUSTIC  
BURNS



CUT OR DAMAGED  
YARNS



BUNCHED OR WADDLED  
YARNS

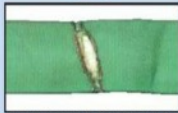

MELTING OR CHARRING



MISSING OR ILLEGIBLE  
TAG



FIBER OPTIC

Lack of light transfer - sling fails



DISTORTED HARDWARE



KNOTS

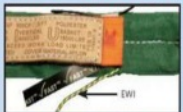

EXTERNAL WARNING  
INDICATOR PRESENT



YARN VISIBILITY



BROKEN STITCHES

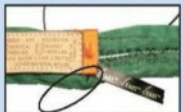

EXTERNAL WARNING  
INDICATOR MISSING



EMBEDDED MATERIALS



SNAGS / PUNCTURES



TATTLETALE MISSING

Sling fails

## Inspection: Wire Rope Sling

**3/6 RULE:** Three broken wires in one strand in one rope lay, or Six randomly distributed broken wires in one rope lay, where a rope lay is the length along the rope in which one strand makes a complete revolution around the rope.

*Lay Length*



**BROKEN WIRES**



**KINKED WIRE**



**ABRADED / WORN WIRE**



**POPPED CORE**



**CORROSION**



**HEAT DAMAGE**



**BIRD CAGING**



**DAMAGED FITTINGS**



## Inspection: Chain slings and hardware

		
BENT LINK	HEAT GOUGE	TWISTED LINKS
		
WELD SLAG	BENT PIN	BENT and DAMAGED THREADS
		
SUBSTANDARD PIN and CORROSION	SPREAD > 15%, PEELED, CRACKED	SEVERE METAL LOSS

## Inspection: slings and hardware continued

All rigging gear requires some form of identification with rated capacity (WLL) legible.

Polyester and nylon slings shall not be used in contact with an object or at temperatures in excess of 180°F.



Hooks shall be removed from service if:

- wear exceeds 10% of original dimension.
- throat opening of 5%.
- Any bend or twist.
- Self-locking hook doesn't lock.

Annual Inspection Color Coding 5 year rotation	
2015	White
2016	Yellow
2017	Red
2018	Green
2019	Orange

## Signalperson: Voice Signals

### Conducting a Voice Signal:

Maintain constant communication with the Operator once a lift move has begun:

- Hold down the microphone key.
- Repeat the function command, talking it through.  
This reassures the Operator the move is proceeding as planned.
- Un-key the microphone at the end of the move.
- Repeat for any follow-on moves.

If the Operator senses a problem, they will stop the move.

**All signals shall be given from Operators perspective.**

3 elements of voice signals

1. Function (hoist, boom, etc), Direction
2. Distance and/or speed
3. Function, stop command





*Example: swing right 50 ft, 25 ft, 15 ft, 10 ft, 5 ft, swing stop*

Only one signalperson at a time, except when STOP or Emergency STOP are given for safety reasons.



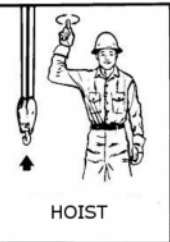
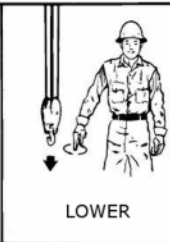
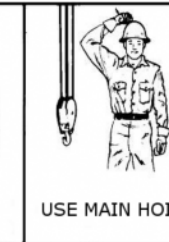
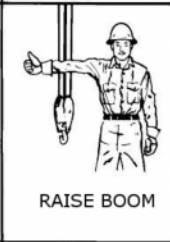
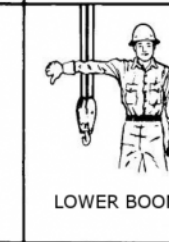

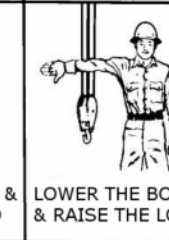

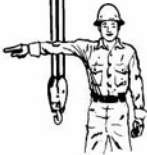

### **Audible Travel Signals:**

- STOP:** one short audible signal      ●
- GO AHEAD:** two short audible signals      ● ●
- BACK UP:** three short audible signals      ● ● ●

# Signalperson: Hand Signals (mobile crane)

 <p>HOIST</p>	 <p>LOWER</p>	 <p>USE MAIN HOIST</p>
 <p>USE WHIP LINE</p>	 <p>RAISE BOOM</p>	 <p>LOWER BOOM</p>
 <p>MOVE SLOWLY</p>	 <p>RAISE THE BOOM &amp; LOWER THE LOAD</p>	<p>LOWER THE BOOM &amp; RAISE THE LOAD</p>

# Signalperson: Hand Signals (mobile crane)

 <p>SWING</p>	 <p>STOP</p>	 <p>EMERGENCY STOP</p>
 <p>TRAVEL</p>	 <p>DOG EVERYTHING</p>	 <p>TRAVEL (Both Tracks)</p>
 <p>TRAVEL (One Track)</p>	 <p>EXTEND BOOM</p>	 <p>RETRACT BOOM</p>

## Signalperson: Hand Signals (mobile & bridge crane)

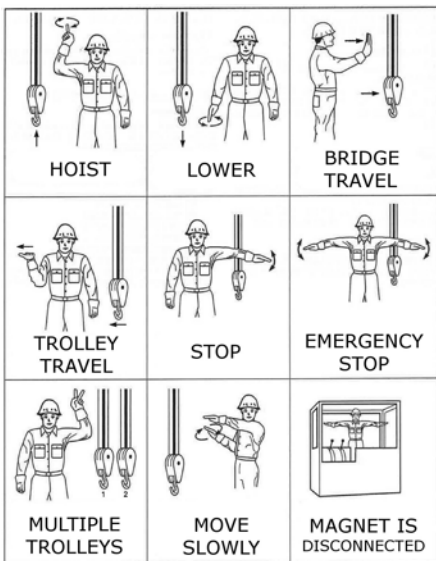
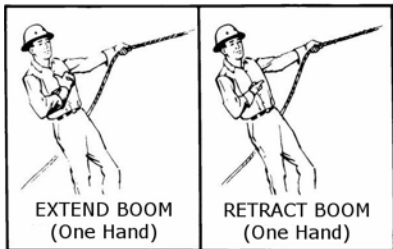

Bridge and Gantry Crane Signals.

## Broderson: Load Chart (7.45 ton)

IC-80-1D: Equipment numbers 7016 & 7045.

D model has a boom extension and All-Wheel steer.

IC-80-1B: Equipment number 2858.

B model has no boom extension and is Rear-Wheel steer.

Max boom is 20 feet, the Extension increases to 30 feet.

Load chart capacities are all Gross Capacities.

### CRANE CAPACITY CHART

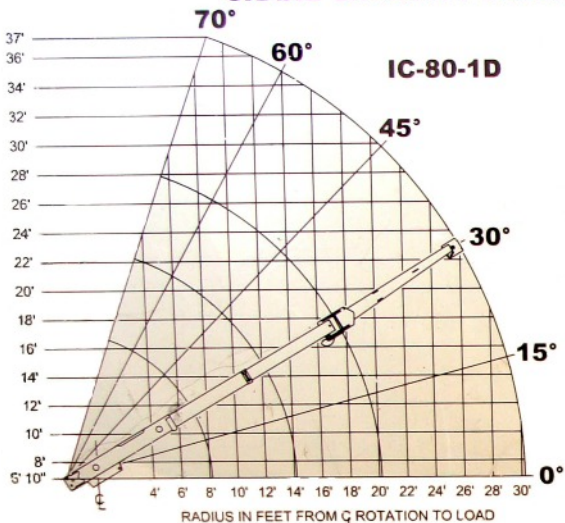

IC-80-1D and 1B

## Broderson: Load Chart (7.45 ton)

It is a Critical Lift if actual Gross Load exceeds 75% of charted capacity.

- Example: If the Gross Load (load + rigging gear + hook&ball) = 4000 lbs., can you pick this up at 16 feet on outriggers, with extension stowed, without it being a critical lift?
- No. ( $4450 \text{ lbs.} \times .75 = 3337 \text{ lbs.}$ )
- $4000 \text{ lbs} > 3337 \text{ lbs}$  so it is a critical lift, move to 14 feet.

ALL CAPACITIES FOR 360° ROTATION

LOAD RADIUS FEET	3 - SECTION BOOM		10' BOOM EXTENSION INSTALLED	
	ON RUBBER	ON OUTRIGGERS	ON RUBBER	ON OUTRIGGERS
5	9500	14900	7000	7000
6	8500	14500	6000	6000
8	6000	10250	5000	5000
10	4150	7700	4000	4000
12	3100	6550	3275	3450
14	2425	5550	2650	3050
16	1975	4450	2175	2700
18	1625	3950	1850	2250
20	1400	3550	1550	2250
22			1325	2250
24			1150	2250
26			975	2250
28			825	2150
30			675	1825

CAPACITIES ON OUTRIGGERS ARE 85% OF TIPPING LOADS. CAPACITIES ON RUBBER ARE 75% OF TIPPING LOADS.

CAPACITIES BELOW **BOLD**LINE ARE LIMITED BY TIPPING. OTHER CAPACITIES ARE LIMITED BY STRUCTURAL OR HYDRAULIC CAPABILITY.

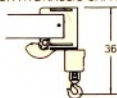

USE SINGLE PART LOAD LINE FOR LOADS TO 9000 LBS.

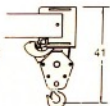

USE TWO PART LOADLINE FOR LOADS TO 14900 LBS.

**IC-80-1D**



## Broderson: Load Chart (7.45 ton)

- Example: If the Gross Load (load + rigging gear + hook&ball) = 10000 lbs., can you pick this up at 6 feet on outriggers, with extension stowed, single part of line, without it being a critical lift?
- No. Single part of line is limited to 9000 lbs. (9000 lbs. x .75 = 6750 lbs.)
- 6750 lbs. Is the max you can lift without it being a critical lift. Install 2-part line block.

ALL CAPACITIES FOR 360° ROTATION

LOAD RADIUS FEET	3 - SECTION BOOM		10' BOOM EXTENSION INSTALLED	
	ON RUBBER	ON OUTRIGGERS	ON RUBBER	ON OUTRIGGERS
5	9450	14900	5900	7000
<b>6</b>	8375	<b>14500</b>	5250	6000
8	5500	10250	4200	5000
10	3850	7700	3450	4000
12	2950	6550	2935	3450
14	2300	5400	2625	3050
16	1880	4250	2300	2700
18	1580	3550	1875	2250
20	1350	3050	1575	2250
22			1250	2250
24			1150	2250
26			950	2150
28			800	1925
30			700	1650

CAPACITIES ON OUTRIGGERS ARE 85% OF TIPPING LOADS. CAPACITIES ON RUBBER ARE 75% OF TIPPING LOADS.

CAPACITIES BELOW **BOLD** LINE ARE LIMITED BY TIPPING. OTHER CAPACITIES ARE LIMITED BY STRUCTURAL OR HYDRAULIC CAPABILITY.

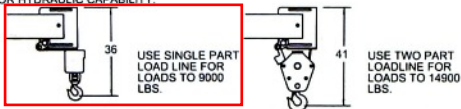

**IC-80-1B**

## Broderson: Load Chart (7.45 ton)

Note: for accurate Hydraulic Oil level indication during pre-check, ensure boom and outriggers are fully retracted.

**CARRY CAPACITY SPEED LIMIT 3 MPH**  
DECK LOAD CAPACITY 12000 LBS. (CENTERED OVER AXLE)

PERSONNEL BUCKET CAPACITY - OUTRIGGERS EXTENDED 300 LBS. PER BUCKET 600 LBS. TOTAL. THE BOOMS ON THIS UNIT ARE ALL STEEL AND HAVE NO LINE VOLTAGE RATING. MAXIMUM HYDRAULIC PRESSURE 3000 PSI.

DEDUCT 120 LBS. FROM ALL "ON RUBBER" CAPACITIES WHEN BOOM EXTENSION IS STOWED ON BASE BOOM.

ALL CAPACITIES APPLY TO OPERATION ON FIRM LEVEL SURFACES.

### OPERATION:

1. READ AND UNDERSTAND OWNERS MANUAL BEFORE OPERATING THIS CRANE.
2. CHECK LEVEL OF HYDRAULIC OIL DAILY.
3. CHECK UNIT FOR VISIBLE DEFECTS AND LOOSE PARTS.
4. SET VEHICLE PARK BRAKE SECURELY.
5. START ENGINE.
6. EXTEND OUTRIGGERS TO SOLID FOOTING.
7. OPERATE ALL HYDRAULIC CONTROLS SLOWLY AND DELIBERATELY FOR SMOOTH MOTION.

THE LOAD HOIST LINE ON THIS UNIT MUST BE 9/16" DIA. 6 X 37-IWRC-EIP WIRE ROPE WITH A MINIMUM BREAKING STRENGTH OF 31,500 LBS.

TIRE PRESSURE 9.00 X 15 12 PR - 95 PSI; 10.00 X 15 12 PR - 85 PSI.

MODEL NO.

IC801D

SERIAL NO.

147196

BRODERSON MANUFACTURING CORP.  
P.O. BOX 14770 LENEXA, KANSAS 66285

C-534-00512

## IC-80-1D and 1B

## Broderson: Load Chart Terminology

**Gross Capacity** = Net Capacity + deductions. These are the numbers on the Load Chart.

**Deductions** = headache ball + hook + rigging gear, etc.

**Net Capacity** = Gross Capacity - deductions. This is the maximum Net Load for the crane configuration.

**Gross Load** = Net Load + Deductions. Use this number when checking the Load Chart. It must never exceed Gross Capacity for the radius and crane configuration.

**Deductions** = headache ball + hook + rigging gear, etc.

**Net Load** = Gross Load - deductions. Actual weight of item lifted.

**Load Radius** - Horizontal distance from center of rotation to CoG of the load.

**Ground Bearing Pressure** - to avoid soil cave-in, the pressure of the outrigger mats/cribbing on the ground must be determined and not exceed:

1. Dirt or Gravel - 1000 psf
2. Asphalt - 2000 psf
3. Concrete - 3000 psf

Determine if the mat size is sufficient:

**Area =  $0.65 \times \frac{(\text{Crane weight} + \text{Load weight})}{\text{max pressure for soil type}}$**

Mat length will be the square root of the result.

# Broderson: Load Chart (4 ton)

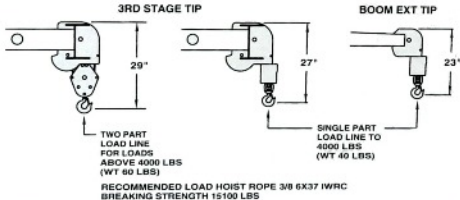
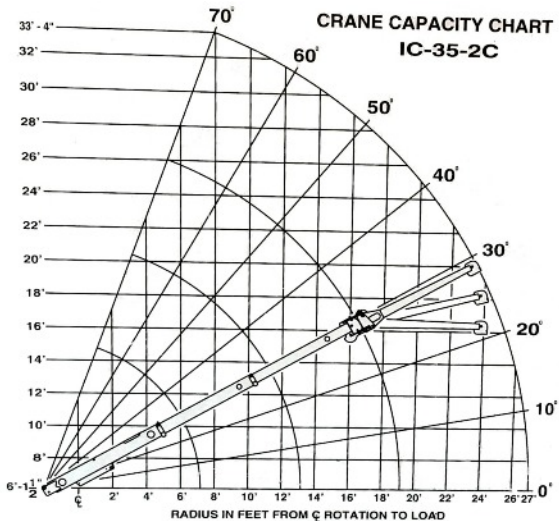

LOAD RADIUS IS THE HORIZONTAL DISTANCE FROM CENTERLINE OF ROTATION TO THE VERTICAL LOAD HOOK WITH LOAD APPLIED. LOAD HOOK, DOWNHAUL WEIGHT, HOOK BLOCKS AND OTHER LOAD HANDLING DEVICES SHALL BE CONSIDERED PART OF THE LOAD EXCEPT FOR HOIST ROPE.

DECK LOAD 6000 LBS MAX (CENTERED BETWEEN WHEELS).

MAXIMUM HYDRAULIC PRESSURE 2600 PSI.

# Broderson: Load Chart (4 ton)

CAPACITIES APPLY TO OPERATION ON FIRM LEVEL SURFACE									
LOAD RADIUS FEET	MAIN BOOM OR EXTENSION CAPACITIES IN POUNDS								
	360° ROTATION				OVER FRONT				
	ON RUBBER	ON OUTRIGGERS	ON RUBBER	ON OUTRIGGERS	ON RUBBER	ON OUTRIGGERS	ON RUBBER	ON OUTRIGGERS	
MAIN BOOM	4	5000	8000	6700	8000				
	5	4000	6800	5800	6800				
	6	2850	5850	5100	5850				
	8	1800	4150	3500	4150				
	10	1250	3200	2350	3400				
	12	900	2350	1750	2850				
	14	700	1850	1350	2450				
	16	600	1500	1100	2150				
	18	500	1250	950	1950				
	19	450	1150	900	1850				
8' BOOM EXTENSION	20	400	1100	850	1600				
	22	300	900	700	1450				
	24	250	800	600	1300				
	26	200	700	500	1150				
	27	150	650	450	1100				
	BOOM EXTENSION ANGLE	8-FOOT BOOM EXTENSION - STRAIGHT OR OFFSET MAIN BOOM ANGLE							
		0°	10°	20°	30°	40°	50°	60°	70°
	+ * 0°	1100	1200	1300	1450	1600	1850	2300	3500
	* 15°	—	—	1100	1250	1350	1500	1700	2050
	* 30°	—	—	—	1100	1200	1300	1450	1600

+ USE 0° FOR STRAIGHT BOOM EXTENSION.

\* USE 0°, 15° OR 30° FOR OFFSET BOOM EXTENSION.

BOOM EXTENSION LOADS MUST NOT EXCEED MAIN BOOM CAPACITY.

CAPACITIES ON OUTRIGGERS ARE 85% OF TIPPING LOADS. CAPACITIES ON RUBBER ARE 75% OF TIPPING LOADS. CAPACITIES BELOW BOLD LINE ARE LIMITED BY TIPPING. OTHER CAPACITIES ARE LIMITED BY STRUCTURAL OR HYDRAULIC CAPABILITIES.

BOOMS ON THIS UNIT ARE ALL STEEL AND HAVE NO LINE VOLTAGE RATING.

CAUTION: BOOM EXTENSION LOADS MUST NOT EXCEED MAIN BOOM CAPACITY. BOOM EXTENSION DEDUCT: 100 LBS. WHEN STOWED ON BASE BOOM. 300 LBS. IN WORK POSITION WITH LOAD ON MAIN BOOM.

#### OPERATION:

1. READ AND UNDERSTAND OWNERS MANUAL BEFORE OPERATING THIS CRANE.
2. CHECK LEVEL OF ENGINE OIL AND HYDRAULIC OIL DAILY.
3. CHECK UNIT FOR VISIBLE DEFECTS DAILY.
4. OUTRIGGERS MUST BE FULLY SET ON SOLID SURFACE.
5. AVOID QUICK STARTS AND STOPS WHEN OPERATING OR DRIVING CRANE.

TIRE PRESSURE 7.50 X 10-16PL 150 PSI.

MODEL NO.

SERIAL NO.

DATE OF MFR.

**IC-35-2C**

BRODERSON MANUFACTURING CORP.  
LENEXA, KANSAS

## Broderson: Load Chart Terminology

If actual radius falls between the chart listings, **use next longer radius**, never split the difference, to determine the Gross Load limitation.

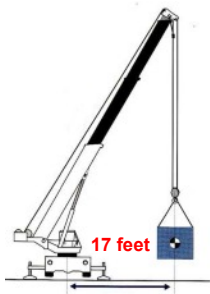

ALL CAPACITIES FO

LOAD RADIUS FEET	3 - SECTION BOOM	
	ON RUBBER	ON OUTRIGGERS
5	9500	14900
6	8500	14500
8	6000	10250
10	4150	7700
12	3100	6550
14	2425	5550
16	1975	4450
18	1625	3950
20	1400	3550

If calculated Gross Load falls between the chart listings, **use next shorter radius**, never split the difference, to determine the Load Radius limitation.

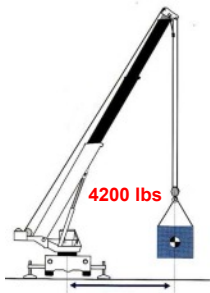

ALL CAPACITIES FO

LOAD RADIUS FEET	3 - SECTION BOOM	
	ON RUBBER	ON OUTRIGGERS
5	9500	14900
6	8500	14500
8	6000	10250
10	4150	7700
12	3100	6550
14	2425	5550
16	1975	4450
18	1625	3950
20	1400	3550

## **Broderson: Standard Lift Plan Checklist**

- Identify Load size, shape, weight, and center of gravity.
- Select and inspect the proper rigging equipment and the method for connecting and disconnecting the load.
- Identify the lifting radii at the pick and set locations.
- Determine head room, hoist height, travel path.
- Select correct size crane for the load to be lifted.
- Job site conditions, examples; obstructions, ground conditions, crane access, SIMOPS, nearby equipment (e.g. live process equipment, overhead power lines).
- Pinch points and crush hazards identified and marked.
- Environmental conditions: wind, temp, visibility, weather.
- Establish roles and responsibilities of the work crew.
- Communication method agreed to by the Crane Operator, Rigger, and Signalperson (i.e. radio, hand signals, etc.).
- A contingency plan for emergencies related or unrelated to the lifting operation.
- Lift area (fall zone) is clear of non-essential personnel, and is properly barricaded.

## Broderson: HUSS Filter

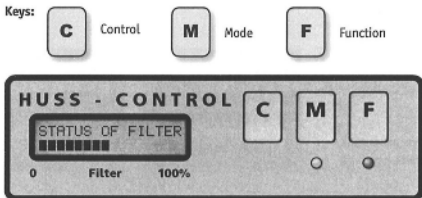

### Regeneration Procedure

1. The vehicle should stand level.
2. Switch off the motor.
3. Ignition: "ON", do not start engine. Voltage is supplied to the Control Unit.
4. Press "M" and hold for 5 seconds. The display will countdown 5 seconds, then regeneration will begin. You can interrupt regeneration by turning OFF the ignition on smaller vehicles, or by pressing the "F" key.
5. Allow several minutes to finish. Filter casing will be very hot.





## Site Safety

### Pinch-points and Crush Hazard Areas

- Identify and mark pinch-points and crush hazard areas.
- Before an employee enters the hazard area, out of view of the operator, the operator must be informed.
- The operator shall not rotate the superstructure until the operator is informed that the employee is in a safe position.

Crane Operators shall observe, or have a Signaller observe, each outrigger during extension, setting, and retraction.

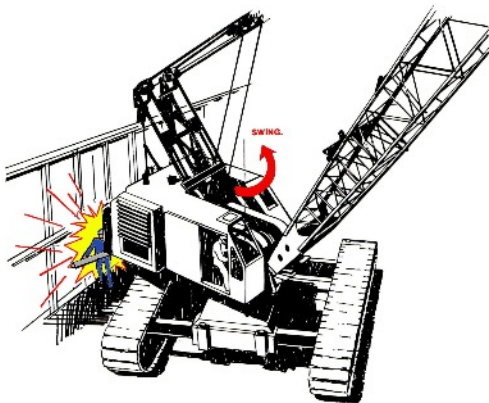

FENCE OR BARRICADE AREAS IN WHICH PERSONNEL COULD BE TRAPPED AND CRUSHED.

## Site Safety

Never walk or work under a suspended load.

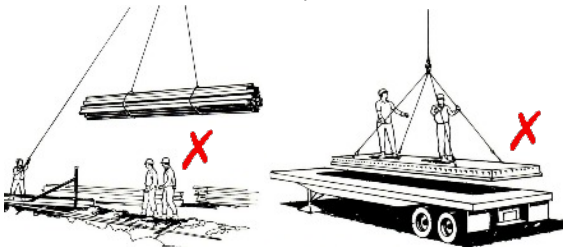

Never ride a load.

Avoid swinging loads over other people.

Use tag lines for positioning and controlling loads.

Spotters are required for all cranes over 15 tons traveling LAR roadways.

Wind speeds

> 20 mph - LTA approval required to continue lift.

> 30 mph - stop Lifts.

Line of Fire: identify rigging line of fire.

Examples: slings and hoists under tension, wire rope under bundle pulling stress.

Avoid standing near or in-line with stressed rigging and cables to avoid snap-back if it breaks.

## Site Safety: Hoists

Chain hoists are intended for use in a vertical or near vertical position only.

Come-alongs can be used vertically, horizontally or on an angle. DO NOT use cheater bars.

Load rating of the supporting structure or anchoring method must be equal to or greater than the hoist. Hoisting from non-process equipment is preferred.

If a process line is to be used as an anchor, select the appropriate pipe size for the load from the Table. Pipe condition must also be considered and risk assessed.

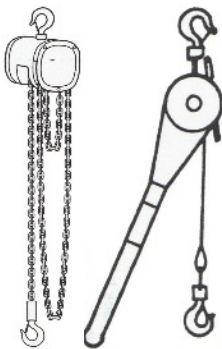

<b>Piping as an Anchor</b>	
Pipe Size	Max Allowable Extra Load (lbs)
<6	Consult Engineering
3	1000
8	2000
10	4000
12	6000
14	7000
16	10000
If load exceeds 10,000 lbs, consult Engineering.	
Before using multiple pipes as an anchor, consult Engineering.	

## Site Safety: Power Lines

Maintain 20 feet clearance from power lines.

### To preventing encroachment / electrocution:

- Use non-conductive tag-lines.
- Erect elevated warning lines, signs, barricades, flags to mark minimum approach distance to the Prohibited Zone.
- Use a Dedicated Spotter:

Dedicated Spotter: a qualified Signalperson whose sole responsibility is to:

- watch the separation between the power line and the equipment,
- watch the separation between the power line and the load line and load (including rigging and lifting accessories),
- ensure through communication with the operator that the applicable minimum approach distance is not breached.

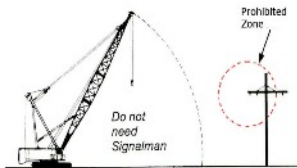
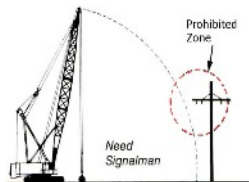

## Site Safety: Power Lines

### Electrocution:

- Can result from contacting the ground and any part of the crane, hoist wire or load simultaneously.
- Can result from stepping across ground voltage differential which occurs as the voltage passes through ground resistance the further it travels.
- The distance of a mere stride can be enough voltage difference to electrocute you.

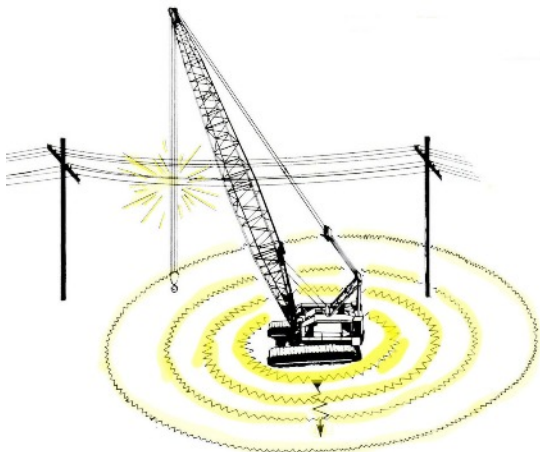

### Procedure: Ground Crew

- Do not touch crane or hoist line or load.
- Maintain balance and hop with feet together or shuffle away from the affected area.

## Site Safety: Power Lines

### Procedure: Crane Operator

- Stay in the crane.
- Attempt to move crane away from electrical hazard.
- If it becomes necessary to abandon the crane, DO NOT step down from the crane. Jump away with feet together.
- Maintain balance and hop with feet together or shuffle away from the affected area.



NO! 



YES! 

# Knots

## Bowline

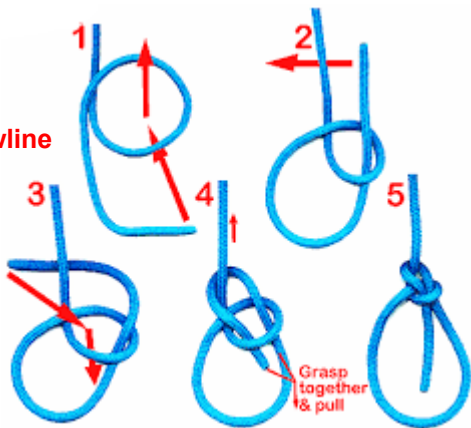

## Clove Hitch

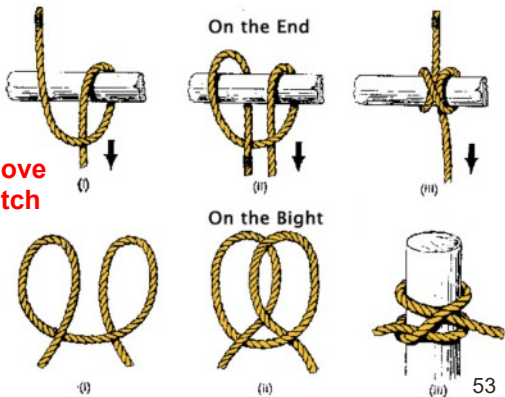

## Knots

### Round Turn & 2 Half Hitches

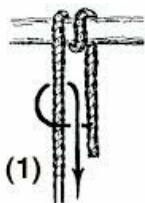

(1)



(2)

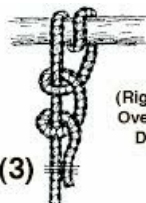

(3)

(Right-handed,  
Over-and-Thru  
Depiction)

### Timber Hitch & Half Hitch

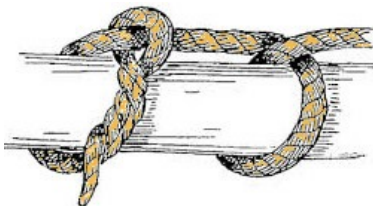



## Glossary

**CoG** - Center of Gravity.

**Critical Lift** - Lifts exceeding 75% of the crane's capacity as configured, multiple crane lift, lifting personnel, lifts near power lines, tilting, high-risk lifts.

**Dedicated spotter (power lines)** - is a qualified Signalperson with the sole responsibility to ensure no portion of the crane or load encroaches upon the prohibited zone.

**D/d Ratio** - the ratio of the diameter around which a wire rope sling is bent, divided by the body diameter of the wire rope sling.

**Gross Capacity & Gross Load** - see page 37.

**Lift Director** - The qualified Rigger that is directly in charge of the work crew performing the task/lift.

**LTA - Lifting Technical Authority** - overall accountability for lifts. Provides technical advice and assurance, ensuring procedures are followed.

**Minimum Connection Diameter** - is the minimum diameter a connection device (shackle, ring, hook) must have to avoid WLL reduction on roundslings.

**Minimum Edge Radii** - unprotected roundslings on corner edges require a minimum radius rounded edge to avoid too much point stress. This can vary from 3/16<sup>th</sup> to 7/8<sup>th</sup> inch depending on WLL.

**Net Capacity & Net Load** - see page 37.

**Prohibited Zone** - the area immediately surrounding an Electrical Hazard in which no lifting operations or other work is allowed. For lifting operations at LAR, the minimum radius of the Prohibited Zone is 20 feet.

**Working Load Limit – WLL** is the rated capacity of Rigging gear based on the ideal rigging situation and configuration. It is calculated in straight line pulls, never side loading.

**Reduced Working Load Limit – RWLL** is when the WLL must be Reduced because of the rigging situation and configuration.

## **References: Standards, Regulations, Policies**

ASME B30.5 Mobile Cranes

ASME B30.9 Slings

ASME B30.10 Hooks

ASME B30.26 Rigging Hardware

CAL/OSHA CSO Construction (1610-1619)

CAL/OSHA GISO General Industry (4884-5049)

HSS-602 Mobile Crane Safety

HSS-604 Rigging and Hoisting

MNT-RIG-023 Inspection & Maintenance Requirements  
for Rigging and Hoisting Equipment

## **References: General**

IPT's Crane and Rigging Handbook, Ronald G. Garby

Journeyman Riggers Reference Card, ITI

Lift-It Catalog

Mobile Cranes, James Headley

Rigging Manual, CSAO











(8/20/2015)