



Riserless Field Abandonment Case Study

Abandonment of Argyll Field in the UK Sector of North
Sea using multipurpose dive support vessel 'Seawell'



In peak winter of 1993, HOC successfully executed permanent abandonment of 18 subsea wells in 260ft. water depth using an innovative approach to well abandonment. The methodology involved squeezing the productive perforations through tubing, cementing the completion in place & removing the Christmas tree/wellhead using a DP DSV 'Seawell'. Few key elements to the success of this incident free project were detailed project planning/preparation, integrated services with consistent crew, batch operation and onboard availability of contingencies.

Riserless Field Abandonment Case Study

Abandonment of Argyll Field in the UK Sector of North Sea using multipurpose dive support vessel 'Seawell'

Field Summary

Discovered in Block 30/24 in 1971, The Argyll field was the first oilfield to be commercially produced in the North Sea in 1975. The initial pressure & temperature were 5400psi & 290°F. By the mid of 1992 the production declined to less than 6000 STBOPD, it became evident that economic production could not be sustained much longer. Hence Hamilton Oil Company (HOC) commenced planning for abandonment.

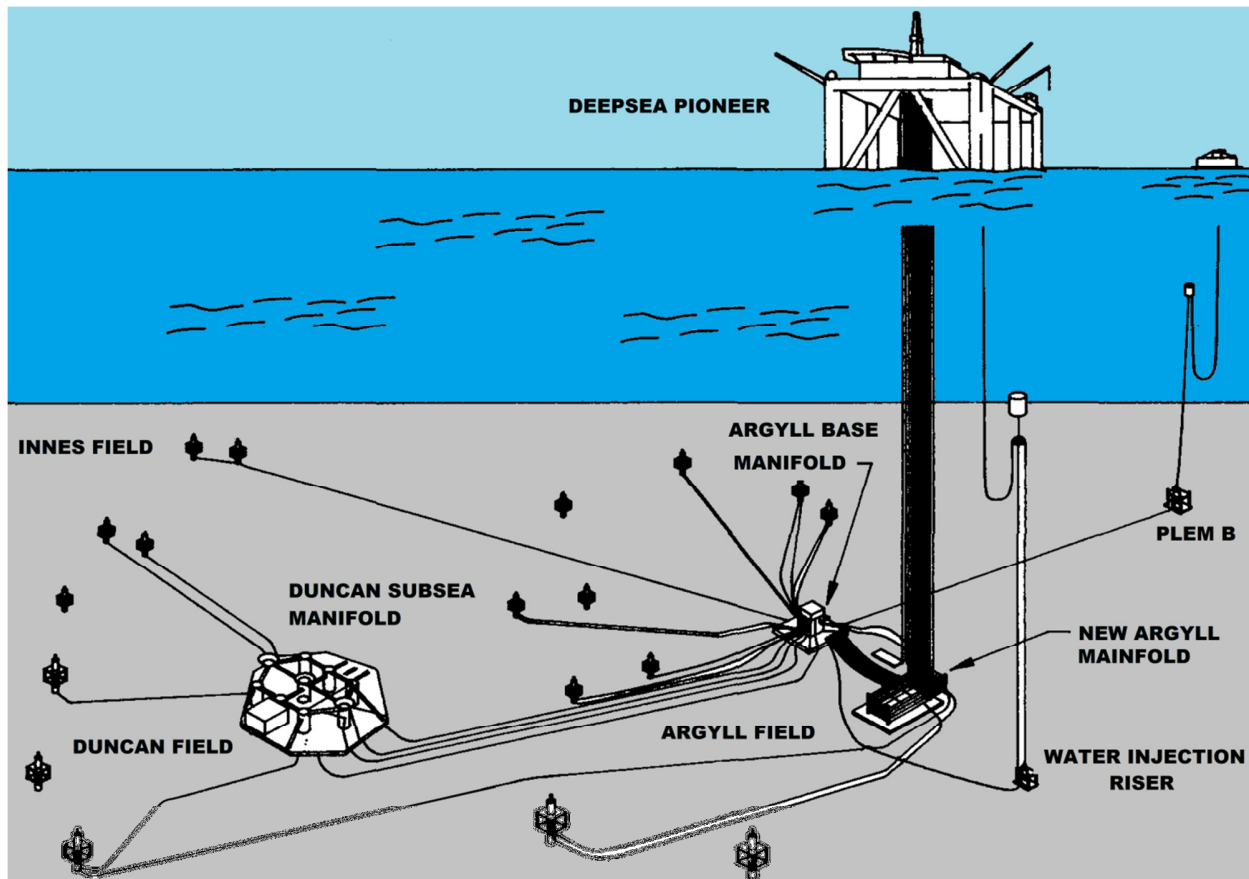

Field Complex Layout

The next section describes the Abandonment Programme from the planning to execution phase.

Well Data

The casing configuration consisted of 30'' & 20'' conductors, with an intermediate 13-3/8'' casing, a 9-5/8'' or 7'' production string, some wells had 7'' production liner. The completion were simple single zone, consisting of 4-1/2'' tubing, wireline retrievable SCSSSV (some were flappers & some were ball type), side pocket mandrel with gas lift or chemical injection valves, permanent production packer with sealbore & a short tail pipe assembly. 5K National trees, concentric TH & 10K WH.

Abandonment Programme

Planning Phase: The planning phase involved the following:

Data: Reviewing of all the well available data (reservoir conditions, stratigraphy, casing, completion & wellhead details, cementing data, well location & environmental conditions), gathering key information for abandonment and checking for accuracy.

Tooling: Collate detailed list of all pulling & running tools required for subsea wellhead & completion equipment. Locate the tools, inspect, service and set aside for potential use in the abandonment programme.

Procedure: Development of the abandonment procedure was based on previous abandonment, servicing experience of subsea wells & innovating thinking. The client, contractors and regulatory body were always kept involved in the discussions. The following approaches were considered with different vessel options:

1. The conventional approach involved recovering of the completion & setting cement plugs through drillpipe. This could have been performed using an anchored or DP semi-submersible drilling rig.
2. The innovative approach involved through tubing cementing the completion in place. In this simplified approach the XT & SCSSSV were retained until the well was fully abandoned. Risk of recovery of old & possibly radio-active, scaled tubing is eliminated. Enquiries with the drilling contracting community indicated there were not any DP drilling rigs available hence the choice of vessel was between anchored semi-submersible and DSV-Seawell. Considering the additional requirement associated with an anchored semi-submersible of three anchor handlers, a dive spread, standby boat & 18 rig moves. It was clear that a multipurpose DSV was most cost effective option.

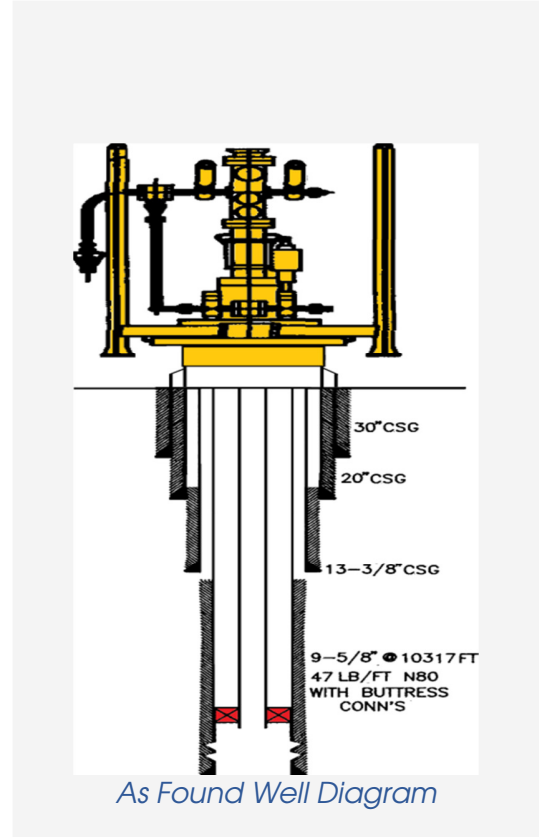

Regulations & Regulatory Bodies: The biggest lesson learned was that the early involvement of the regulator bodies is very worthwhile exercise. At that time the only published guideline was that the seabed must be cleared to 10' below the mudline of all the well equipment. The Health & Safety Executive (HSE) considered each well on its own merits, however the key points were:

- 1.) All the production zones must be effectively isolated from each other.
- 2.) All production zones must be effectively isolated from the seabed.
- 3.) All other potentially productive zones which are either over-pressured or HC bearing must be effectively isolated from the seabed.

Prior to the Deepsea Pioneer (shown in field complex layout page 1) leaving the field, the wells had to be temporarily suspended by bullheading kill weight fluid & by closing all valves on XT. After submission of the outlined plan to HSE, verification of primary cement barriers was identified as areas of further consideration. But client was given approval to proceed with the tendering of the workscope.

Tender: An invitation to tender was issued to pre-qualified contractors for a fully integrated service package in Sep 1992, contract was awarded during Nov 1992 based on a 1993 well abandonment campaign.

Execution Phase: This phase involved the following:

Pre-Operational Work: Forming a project team, preparing well specific programmes including cement recipes, finalizing regulator body acceptance of the programme, finalizing equipment design & layout, contingency equipment testing prior to mobilization, obtaining certification for HC handling equipment and subsea well control equipment, completion of safety management system audit for abandonment spread, developing vessel operability envelopes, bending moment analysis of XT/lubricator simulating environmental & operational loads and completion of a Hazard and Operability Study (HAZOP) with three distinct areas subjected to formal review:

- 1.) The piping and instrumentation diagram for the HC handling, cementing and subsea equipment
- 2.) The well specific abandonment procedures
- 3.) The contingency procedures

This exercise (HAZOP) helped everyone involved (operator, contractor, co-contractor & offshore/onshore personnel) gain clear understanding of the workscope, advantages/limitations of the abandonment spread and of the professional manner in which the project was to be conducted. Seawell being fully certified as an offshore installation the existing fire/gas detection and deluge systems were already adequate for the operations. As cementing was a quintessential part of the project considerable attention was spent on ensuring that the cement system would have high reliability, large storage facilities and be able to perform the highest quality cement treatments by having high quality bulk handling, cement mix system, instrumentation package and a self-contained offshore laboratory (to ensure the highest standards of quality assurance).

Offshore Operational Work: The operations were batched and were categorized in two parts: 1.) Well Plugging 2.) Christmas Tree/Wellhead recovery. The batch operations had few significance benefits:

- 1.) The efficiency of high cost rental equipment and skilled service personnel was maximized
- 2.) Focusing on repeating one type of operation enabled the crews to attain a higher level of performance
- 3.) Performing the workscope in two separate programmes gave greater flexibility to client and contractor regarding the scheduling.

The order of the wells was based on combination of experience and well history with the wells with highest risk planned for the latter part of the programme. The following procedure was followed on each well: **Part I**

- 1.) Move on location.
- 2.) Run guidelines and establish well status. Pull high pressure tree cap.
- 3.) Run subsea lubricator. Deploy flexible risers and take control of the well.
- 4.) Bullhead kill weight fluid to the perforations.
- 5.) Perforate the tubing above the production packer.
- 6.) Bullhead/circulate the 'A' annulus content to kill weight fluid.
- 7.) Bullhead/circulate cement plug#1 to the perforations and squeeze. WOC. Tag TOC & Pressure test the plug.
- 8.) Circulate dye marker to confirm circulation volume & circulate cement plug#2 filling tubing & annulus to 3000' below seabed. WOC. Tag TOC.
- 9.) Perforate tubing and production casing at 2000'.
- 10.) Bleed off any gas from the annulus. Circulate to seawater and establish injectivity.
- 11.) Circulate cement plug#3 to perforations and squeeze to 13-3/8" x 9-5/8" annulus. WOC. Pressure test plug.
- 12.) Perforate tubing, 9-5/8" csg & 13-3/8" csg at 1000'.
- 13.) Bleed off any gas from the annulus. Circulate to seawater and establish injectivity.
- 14.) Circulate cement plug#4 to perforations and squeeze to 20" x 13-3/8" annulus. WOC. Pressure test plug.
- 15.) Cut tubing 30' below the tubing hanger with an explosive charge.
- 16.) Vessel off well.

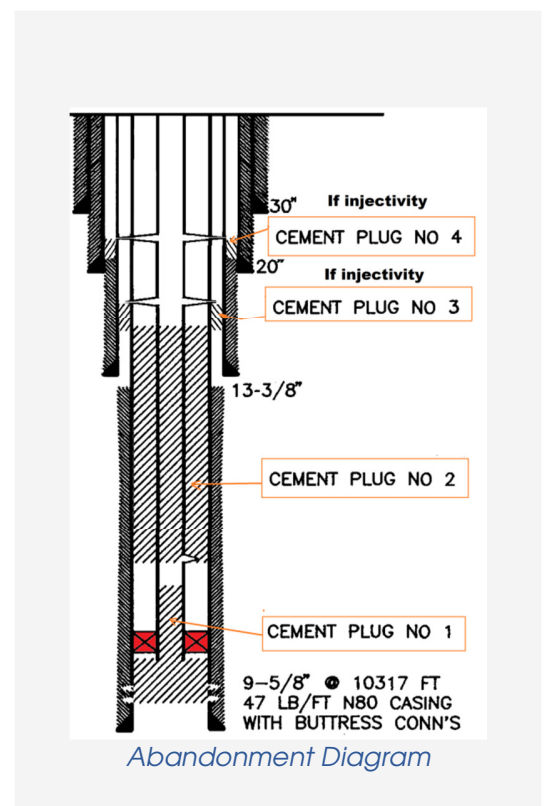

Part II

- 1.) Recover subsea Christmas tree and tubing hanger.
- 2.) Explosively cut all casing strings at least 12' below mudline.
- 3.) Recover wellhead and casing stumps.
- 4.) Remove any local debris and perform sit scan.

The following critical equipment was quintessential for the success of the project:

Vessel: The selected vessel, 'Seawell' was a multipurpose, dynamically positioned monohull DSV, as well as a fully certified installation. Bed space 144, S61 rated helipad. It had 18 man saturation system, rated to 450m, with two three-man bells. Equipped with 29m derrick positioned over a 5 x 7m moonpool, providing 130tons heave compensated lifting arrangement through the moonpool. Cursor deployment systems for both dive bells and subsea lubricator. Other key equipment included 2 cement pumps, 2 well kill pumps, integral cement room, certified choke manifold & piping, 1500bbl of storage capacity. 2x 65tonne cranes with 130tonne heave compensated lift capacity.

Subsea Lubricator: The system comprised of hydraulic actuated subsea BOPs, fail safe wireline cutting gate valve, sections of riser and remotely operated stuffing box. These are mounted on a guidebase which also houses subsea hydraulics and accumulators. Hydraulic connector mounted on the based of the lubricator provides access to the XT. The system functions/XT functions are remotely controlled using an umbilical and also has an emergency disconnect mechanism at the end of the umbilical. Depressurization of umbilical will result in fail safe closure BOPs and gate valve on lubricator, XT valves and SCSSSV.

Other equipment:

High quality bulk handling, cement mix system and instrumentation package, eight silos 450tonne, cement mixer with a 50bbl twin displacement tank and slurry averaging system was installed in the cement room. On site portable pressurized consistometer, a portable curing chamber with compressive strength tester, high temperature fluid loss apparatus and the Nowasco EXPERT data acquisition. Cement was pumped into the well via flexible riser (2" high pressure hose) & returns taken via 2" flexible riser through the choke manifold into hydrocarbon (HC) handling/fluid returns system. The flexible risers had double isolation and disconnect procedures. Although the procedures were developed to minimize the potential for recovery of HC to surface it was essential part of the safety and environmental

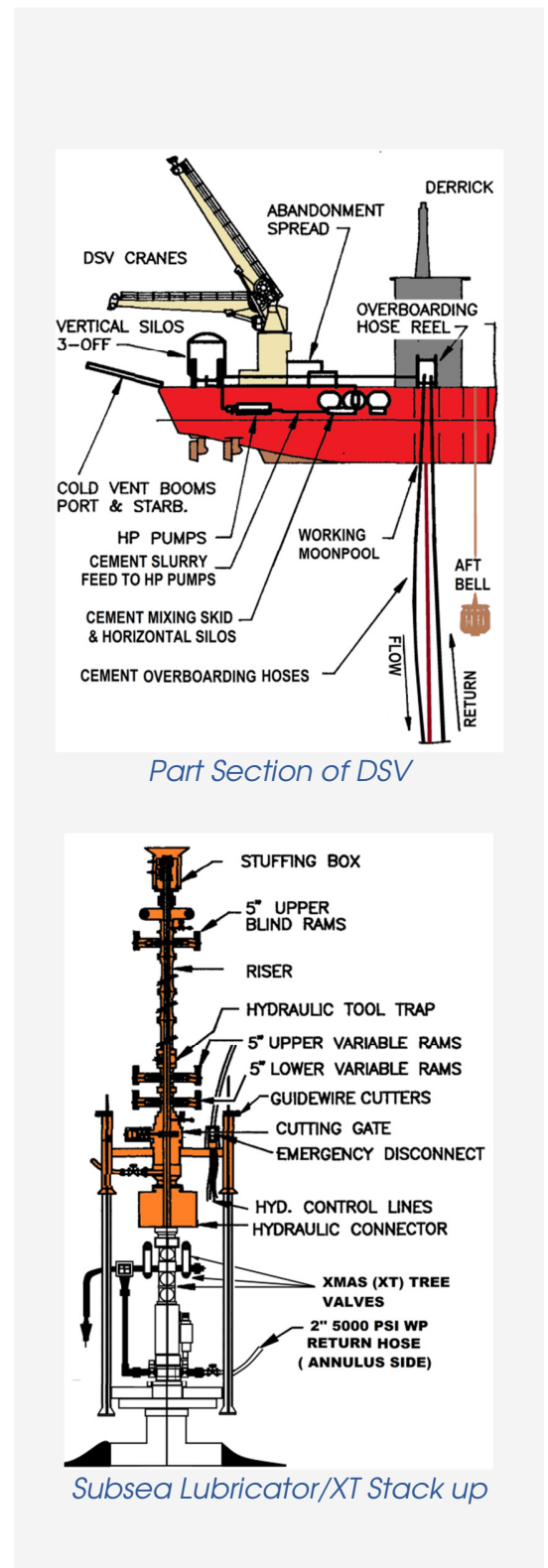

considerations to have an appropriate HC handling system onboard. A 200bbl storage tank and high rate venting system was incorporate in the choke manifold and subsea flexible riser reel system.

Camco provided Slickline services and Atlas provided electric line perforating services. Wireline lockout devices were manufactured for all types of downhole safety valves in case problems were encountered in running the perforating guns through the downhole safety valves.

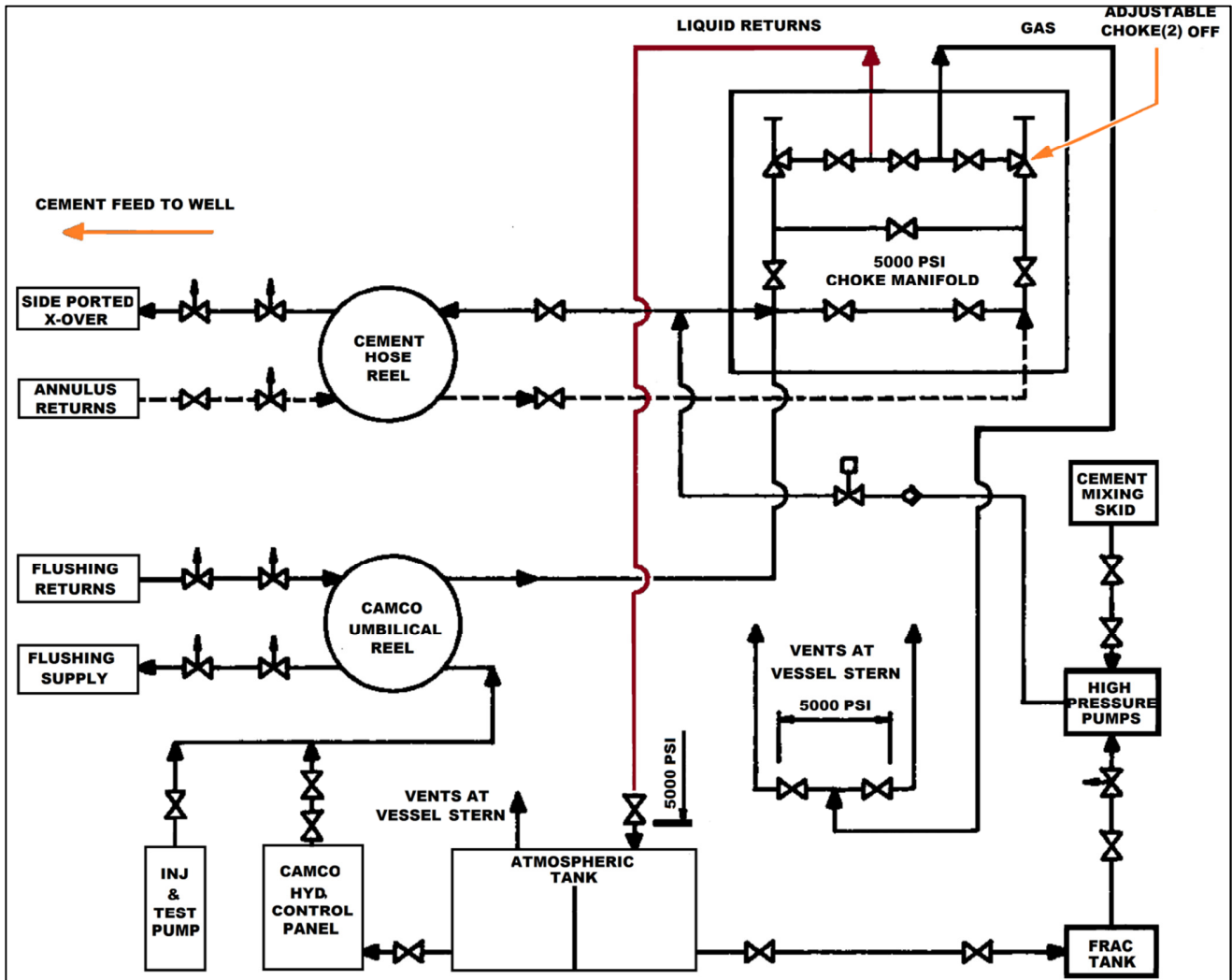

Flow Diagram

Operational Review

It was anticipated that the well abandonment programme would take approx. 81 days. In practical the 18 well programme took only 47 days. The well plugging took a total of 30 days and the tree/tubing

hanger/WH recovery took 17 days. The total abandonment programme was achieved at a cost of £ 5.8 MM compared to the original budgeted cost of £ 11.7MM.

While carrying out the Christmas tree/wellhead recovery the detailed lifting procedures worked effectively and there were minimal problems with functioning pulling tools in the subsea environment. During the well plugging phase there were very few operational problems and all the equipment and procedures worked as expected. There was no requirement for a drilling rig to perform additional well work.

During the whole campaign 41 plugs (6800bbl) were mixed and pumped, there was no cementing downtime. As outlined in the procedure (page 4) there were four different types of cement plugs pumped, plugs less than 50bbl were batch mixed in the blender, plugs greater than 50bbl cement were mixed on the fly (with mix water pre-mixed) with the slurry averaging system. The location of the plug was verified by accurate measurement and recording of the volumes pumped using the EXPERT system. The integrity was verified by pressure testing.

Performance monitoring techniques were used and these charts were update continually. All personnel were involved in following progress compared to the target and this short term goal-setting technique had proven to be an excellent tool for monitoring performance and motivating the offshore crew.

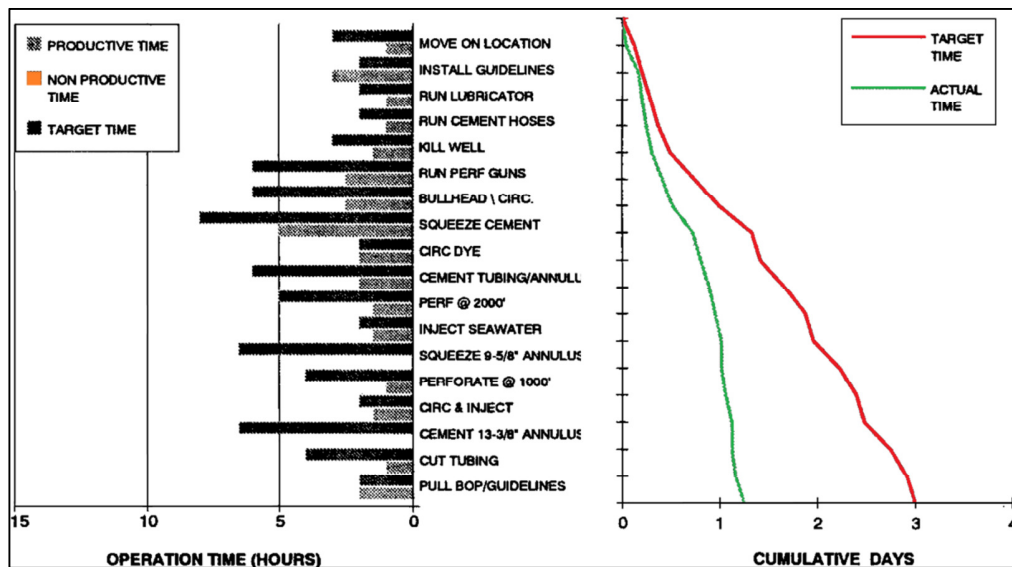

Performance Chart (Well 30/24-25)

Reference: An Innovative Approach to Argyll Field Abandonment-SPE 26691, Sep 1993.