



ROBOT INSTRUCTION

SMARTSHELL™ (MR01/MR02)



Please read this manual carefully before operating, and keep it properly.

Contents

Safety Instructions	21
Precautions	23
Product Description	25
Instructions for Use	31
Maintenance	35
Troubleshooting	38
After-sales Service	39

Safety Instructions

- Do not bring the vacuum cleaner close to the heat source, radiation or burning cigarettes. Do not absorb the following objects:
 1. All liquids such as water and solvents;
 2. Construction dust and garbage such as lime and cement ash;
 3. Heating objects, such as carbon heads and cigarette butts still burning;
 4. Sharp fragments, such as glass;
 5. Flammable and explosive materials, such as gasoline or alcohol products.
- Only authorized technicians can disassemble the machine.
- Children, people with disabilities or lack of common sense and experience in household appliances mustn't use this product without the guidance of dedicated personnel.
- This product is only intended for indoor use.
- Do not touch the power cord, outlet or power adapter with wet hands.
- Please empty the dust bin when it is full before using the product.
- The power must be turned off before cleaning or repairing, or the vacuum cleaner isn't used temporarily.
- Do not immerse the vacuum cleaner in water and avoid exposure to heat or the sun to avoid fire.
- Only use genuine power adapter, or else it may damage the product.
- Cut off the power before taking out the battery. Do not disassemble the battery of the main unit. For replacement, please contact the after-sales personnel.
- Recycle the battery pack before disposing of the product.
- Keep the pole or connector away from conductors to avoid short circuit.
- Before using the product, remove all fragile items (such as glasses, lamps, etc.) and items that may wrap around the side brush, suction channel and drive wheels (such as wires, curtains, etc.) from the floor.

- Do not place this product in a place where it drops easily (such as a table or chair).
- The product may not work properly under strong light.
- Do not bend the wires excessively or place heavy objects and sharp objects on the machine.

Charging tips:

1. Charging time may be extended in the following cases:
 - a. When the room temperature exceeds 30°C;
 - b. Charge immediately after stop running.
2. Regardless of the time of use, please charge after cleaning.
3. When not charging, it is recommended to unplug the power plug in time.
4. If your machine is not used for a long time (over 2 months), please unplug the power cord; however, in order to ensure the battery life, please fully charge it every 2 months.
5. In the charging process, the body or power adapter may be hot, which is normal. Please feel free to use it.

PRECAUTIONS

Warning:

1. Do not use the product in wet or watery areas.
Roll up the edges of the carpet or use it on a short-haired carpet.



2. It is recommended to add a protective fence to the suspended area to prevent the product from falling.

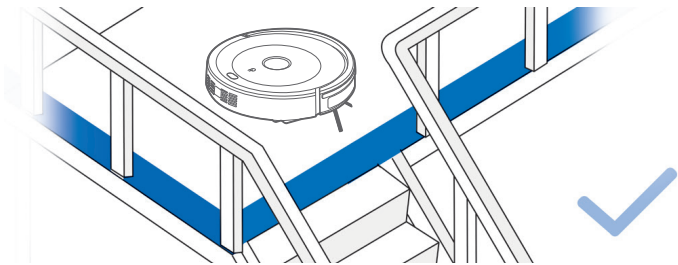

3. Please arrange the location to be cleaned, and put the furniture and chairs in the proper position to avoid the machine being trapped.

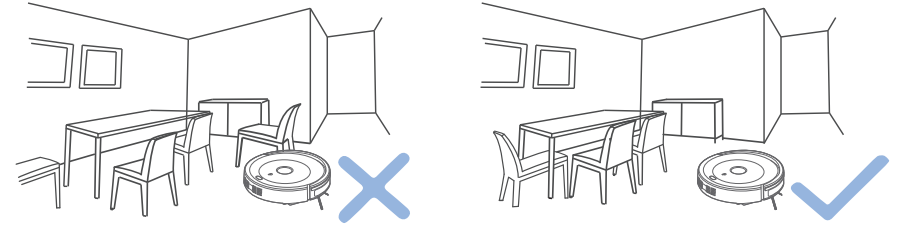

4. Be sure to remove the power cords and other debris scattered on the ground before use to avoid catching or blocking the product.

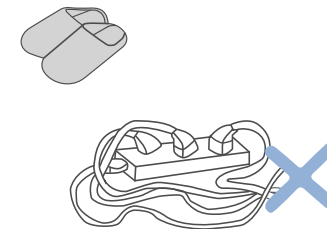

Product Description

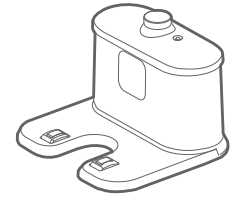
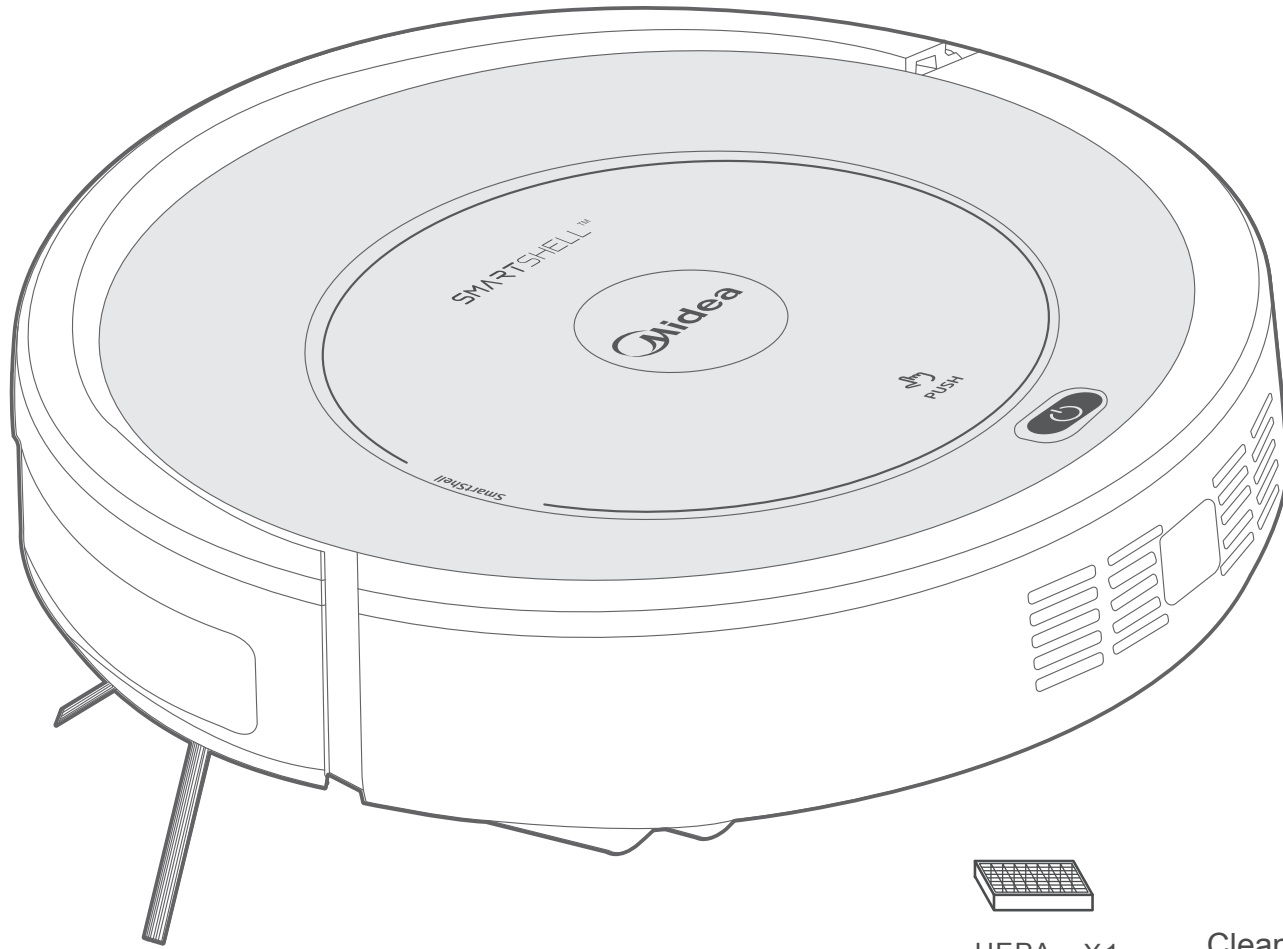

Charging dock X1

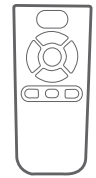

Remote control X1



HEPA X1



Cleaning tool X1



Batteries for remote control X2

MR02 only:

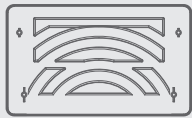

Cloth bracket X1



Dry cloth X1

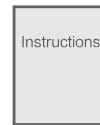

Instruction manual package X1



Side brush X4

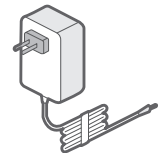

Power adapter X1

Product Description

Illustration of Main Unit

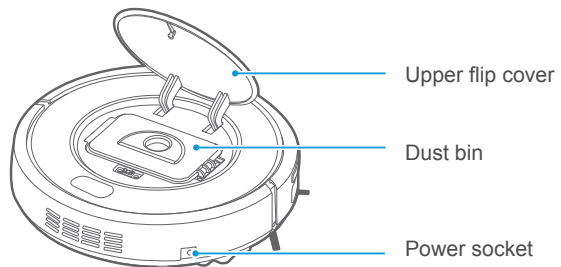
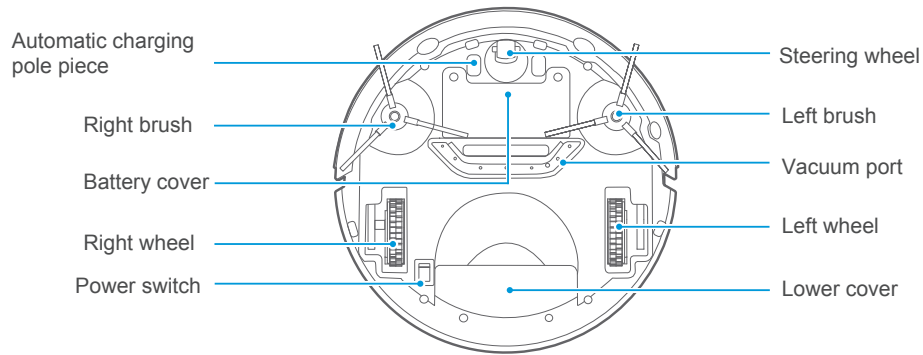
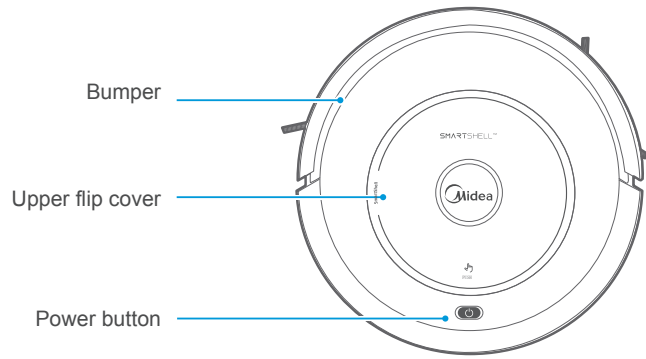

Dust bin

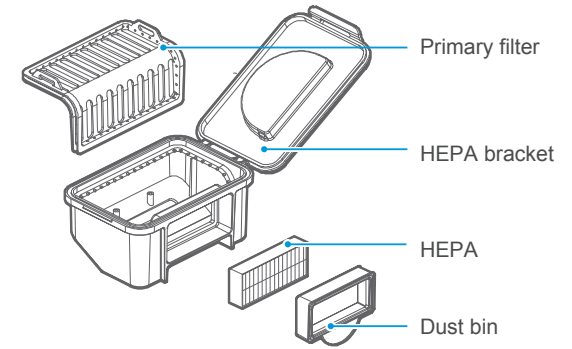



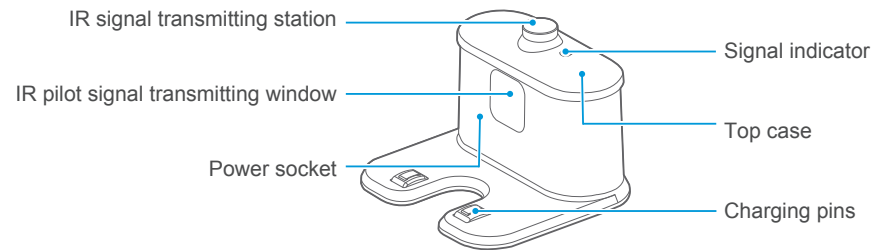





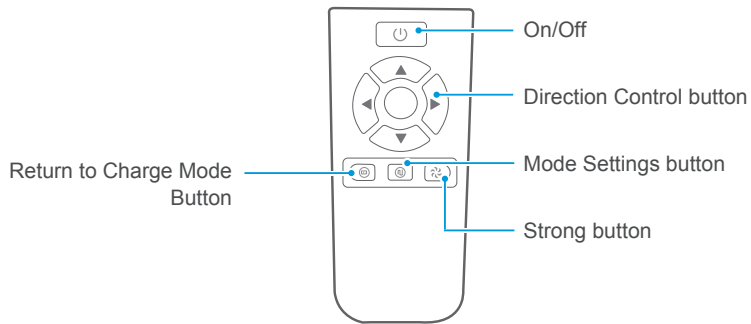



Charging dock



Product Description

Description of Remote Control Panel



- 1 You can use the remote control like the remote control of the TV. Turn on the switch on the bottom of the machine and press the “” button to control the machine with the buttons on the remote control. (The machine enters sleep state if there is no operation in one minute; you can press “” to wake it up. If there is no operation in 15 minutes, the machine power turns off, and you need to press the “” button on the machine to turn it on)
- 2 : When the machine is in standby state, press  to make it enter cleaning mode. Press the direction buttons to control the direction in which the machine travels
- 3 : When the machine is in standby or cleaning state, press  to make it enter return mode and look for the charging dock.
- 4 : When the machine is in standby state, press  to make it enter the cleaning state directly. When the machine is in cleaning state, you can press  to switch the cleaning mode. For details, see P33-P34.
- 5 : Press  on the remote control to enter strong cleaning mode. (Strong cleaning mode is to increase the suction power in spot cleaning mode.)

Note

Install two AAA batteries before use. In the vicinity of the charging dock, the machine may not be able to recognize the commands from the remote control. If you do not use the remote control for a long time, remove the batteries.

Buttons and Indicators

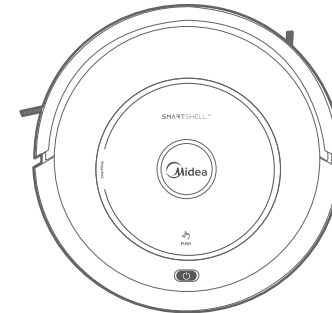

Description of “” button and indicators

- 1 Turn on the power switch at the bottom of the machine. If the machine is on the ground and working normally, the indicator will flash slowly in blue.
- 2 “” clean button, the buzzer beeps, and the indicator first flashes quickly in blue; if the machine runs normally, the indicator stays blue, or else the machine resumes standby and the indicator restores the original state;
- 3 In case of failure during operation, the indicator reacts according to different faults. See Troubleshooting on P38 below;
- 4 When the battery is low, the indicator flashes quickly in red;
- 5 In charging state (when the machine is placed on the charging dock or connected with the adapter), the indicator flashes slowly in red; when fully charged, the buzzer beeps 5 times, the red indicator goes out, and the blue indicator turns on.

Instructions for Use

Battery Charging

- 1 Turn on the power switch at the bottom of the machine. If the machine is on the ground and working normally, the indicator will flash slowly in blue;

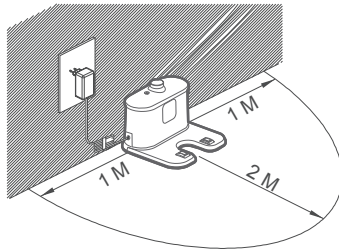

- 2 Turn on the power switch at the bottom of the machine, press the “⏻” button, the indicator flashes slowly in blue, and the machine enters standby mode.
- 3 You can charge the machine in either method below:
 - A. Plug the power adapter directly into the machine and turn on the power at the other end.
 - B. Plug the power adapter to the charging dock and turn on the power, point the remote control at the machine and press the “🔌”, and the machine will recharge automatically.

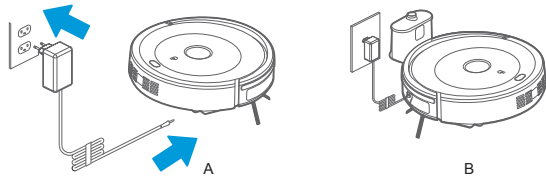

⚠ Note

- A. Make sure that the power switch is on before charging, or else the red indicator will flash rapidly, accompanied by the buzzer sound;
- B. When the machine is charging, the “⏻” clean button changes to slowly changing red color;
- C. After charging, the buzzer will beep 5 times (each charging time does not exceed 5 hours);
- D. When the machine is used for the first time, please run out the electricity of the machine;
- E. After the power is used up, please recharge the machine as soon as possible;
- F. If you do not use the machine for a long time, turn off the power switch.

- 4 Auto charging: When the cleaning is completed or the battery is too low, the machine will automatically find the charging dock to charge.

⚠ Note

1. Please keep the charger base powered. Otherwise, the machine can't find the charging dock for charging. This product complies with the European ERP energy consumption standard.
2. High-speed flow sound of the airflow is normal when the machine is running.

Product Operation

- 1 When cleaning without using a dry cloth, place the machine on the ground, turn on the power switch at the bottom of the machine, press the “⏻” button or press the On/Off button on the remote control to start the machine; press the “⏻” button or the On/Off button again to pause the machine; when cleaning with a dry cloth, first turn on the power switch at the bottom of the machine, put the rag bracket (including rag) on the base of the machine, put the machine on the ground, turn on the power switch at the bottom of the machine, press the “⏻” button or press the On/Off button on the remote control to start the machine; press the “⏻” button or the On/Off button again to pause the machine. (Dry cloth cleaning is only available for MR02)

- Press and hold the On/Off button on the remote control or the “⏻” button on the machine for 3 seconds to put the machine into sleep mode. Press and hold the “⏻” button to wake up the machine. The remote control can be activated by pressing the On/Off button on the remote control in the first 15 minutes when the machine enters sleep state.

⚠ Note

- Use dry mopping method with the rag; (MR02 only)
- Make sure that the dust bin has been installed before cleaning.
- If there is no operation within 1 minute, the machine will automatically enter the sleep state. After 15 minutes, the machine automatically turns off to prevent the battery from being over-discharged and damaging the battery life. If you do not use the machine for a long time, turn off the power switch.

Cleaning Mode Operation

Auto cleaning

In auto cleaning mode, the machine auto cleans the room and adjusts the cleaning mode according to the environments. You can press the “⏻” button on the main unit or the remote control to enter the auto cleaning mode.

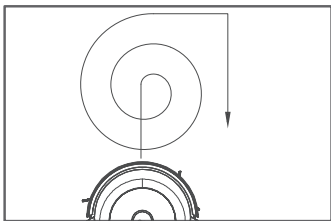

Spot cleaning

Press  on the remote control to switch to spot cleaning mode.

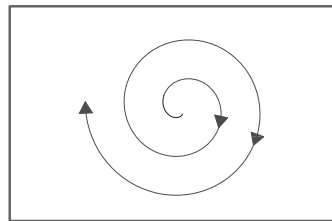

Random cleaning

Press  on the remote control to switch to random cleaning mode.

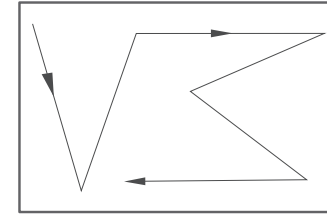

Edge cleaning

Press  on the remote control to switch to Edge cleaning mode, and the machine will clean the edges of the obstacle with its brush.

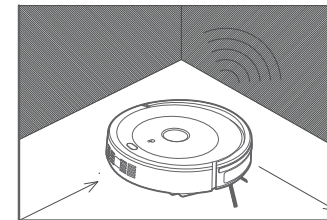

Zigzag cleaning

Zigzag cleaning is mainly used for quick and efficient cleaning in large areas without furniture.

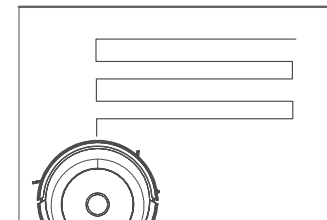

Maintenance

Dust Bin and Filter Cleaning

Please empty the dust bin after each use; the specific steps are as follows:

1 Press the “” mark on the middle cover to open it

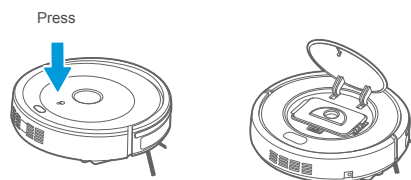

2 Take out the dust bin

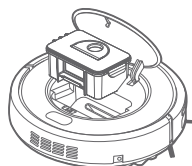

3 Take out the HEPA

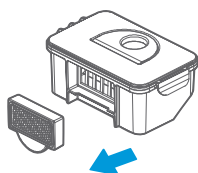

4 Open the dust cover and remove the primary filter

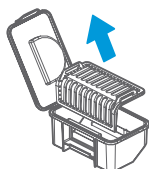

5 Pour out the garbage in the dust bin

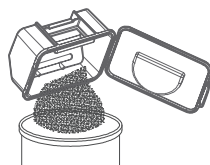

6 Rinse the dust bin and primary filter with water and clean the HEPA with cleaning tool

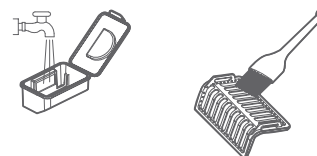

7. Reinstall the primary filter and HEPA back into the dust bin

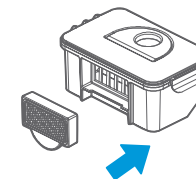

Tip:

- A. Check whether the side brush is damaged or whether there is any foreign matter on it.
- B. Clean the side brush with the cleaning tool or rag.
- C. Replace the side brush in time if it is damaged and can't be used:
 1. Pull out the old side brush directly;
 2. Press the new side brush on the bottom of the machine.

NOTE

1. It is recommended to wash the filters after using for 15-20 days. The maximum life of the HEPA is 24 months.
2. Make sure that the filters are dry before installation.
3. HEPA and primary filter are all replaceable accessories. For accessories, please contact Midea after-sales service: RoboticVC@midea.com.
4. Do not expose the filters to sunlight.

Cleaning Machine

- 1 Cleaning sensor and wheels: Gently wipe the sensor and the wheels with the cleaning tool or soft cloth, as indicated on the right.

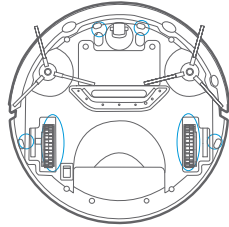

- 2 Clean the charging terminals: Clean the charging terminals on the charging dock with the cleaning tool or soft cloth, as indicated below.

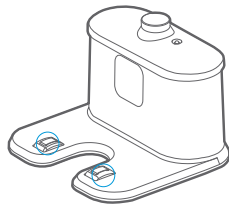

- 3 Clean the suction channel: Clean the suction channel with the cleaning tool or soft cloth, as indicated on the right.

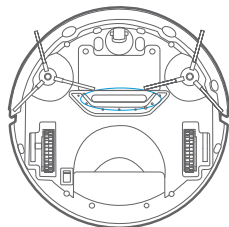

Troubleshooting

Please refer to the table below if the product has any problem during use.

Problem	Possible cause	Solution
During work, the machine stops suddenly and the blue LED stays on	The main unit is suspended (cliff sensor detects continuous falling hazard or any wheel is floating).	Re-position the main unit back to the ground and restart it.
Place the machine on the ground, turn on the power switch, press the "⏻" button, the blue LED stays on (the machine is not connected to the charging dock or adapter)	Cliff sensor failure or wheel suspension switch failure	Clean the cliff sensor, if it still doesn't restore, send it to the After-sales Service Center
The machine doesn't change direction when it hits an obstacle	Bumper sensor error	Check the sensitivity of the bumper, and whether there is a foreign object
When charging, the red LED flashes quickly, accompanied by a buzzer sound	The machine's power switch is not turned on.	Turn on the power switch
Red LED flashes quickly	The battery voltage is too low	Charge the machine
Blue LED flashes once, red LED flashes once	The side brush of the main unit is wrapped or jammed	Move the machine to flat ground and remove the wrap
Blue LED flashes once, red LED flashes two times	The main unit bumper is not flexible	Loosen the bottom screws of the bumper
Blue LED flashes once, red LED flashes three times	Main wheel set is blocked	Clear the blockage

After-sales Service

Midea Smart Vacuum Cleaner provides users with the most perfect after-sales service. In the case of normal use of the product, you are entitled to free return and replacement service for the machine within one year from the date of purchase. The service must meet the following conditions:

1. This product is only for household use. Please operate according to the instructions strictly. We are not responsible any failure caused by violation to the instructions and household purpose.
2. Consumables (side brushes, adapter, filters, batteries, cleaning brush, mop cloth, etc.) are not covered by one-year free service. To purchase consumables, please contact Midea After-sales Service: Email: RoboticVC@midea.com
3. Any failure caused by violation to the instructions or disassembly by unqualified personnel is not covered by the warranty.
4. For maintenance beyond the warranty and purchase of spare parts, please contact Midea After-sales Service: RoboticVC@midea.com
5. When contacting After-sales Service, please fill in the warranty information, take a photo and attach to the email so that you can get a reply as soon as possible.

If the product fails to meet your expectations, please contact Midea After-sales Service:

Email: RoboticVC@midea.com

Jiangsu Midea Cleaning Appliances Co., Ltd.

No. 39, Caohu Avenue, Xiangcheng Economic Development Zone, Suzhou, Jiangsu, China, 215131