

**KNOWLEDGE INSTITUTE OF TECHNOLOGY
DEPARTMENT OF MECHANICAL ENGINEERING**

ROBOTICS

K.V.Rangasamy

AP/MECH

UNIT I FUNDAMENTALS OF ROBOT

- Robot - Definition
- Robot Anatomy
- Co ordinate Systems, Work Envelope
- Types and Classification- Specifications-
- Pitch, Yaw, Roll, Joint Notations,
- Speed of Motion, Pay Load- Robot Parts and their Functions-
- Need for Robots-Different Applications.

ROBOT

“An robot is a programmable, multi-functional manipulator designed to move materials, parts, tools, or special devices through variable programmed motions for the performance of a variety of tasks”

ROBOT LAWS

Three Laws of Robotics:

1. A robot may not injure a human being, or, through inaction, allow a human being to come to harm.
2. A robot must obey the orders given it by human beings except where such orders would conflict with the First Law.
3. A robot must protect its own existence as long as such protection does not conflict with the First or Second Law.

ROBOT ANATOMY

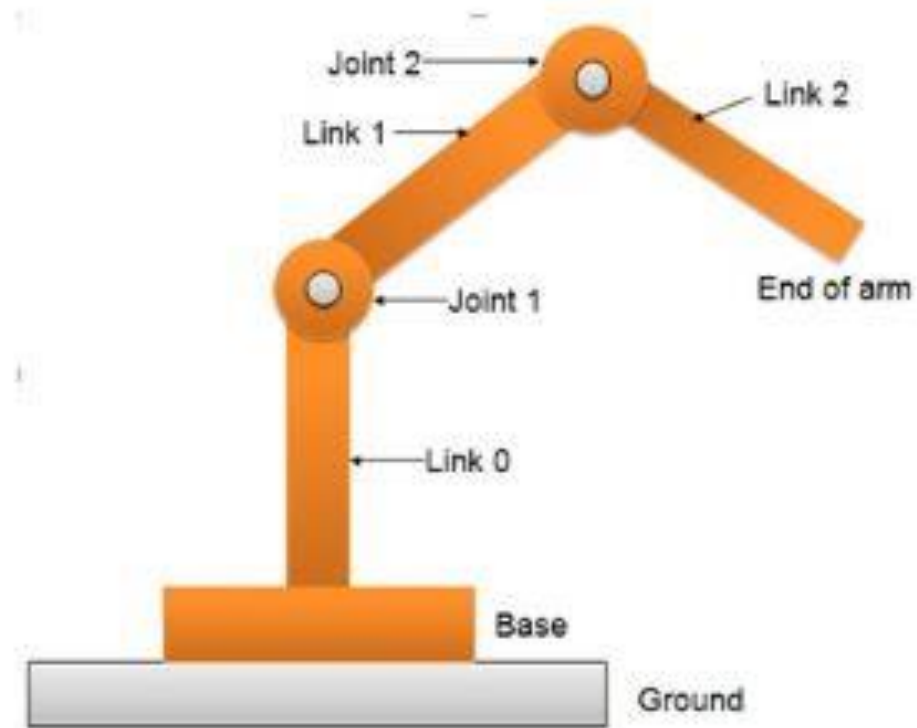
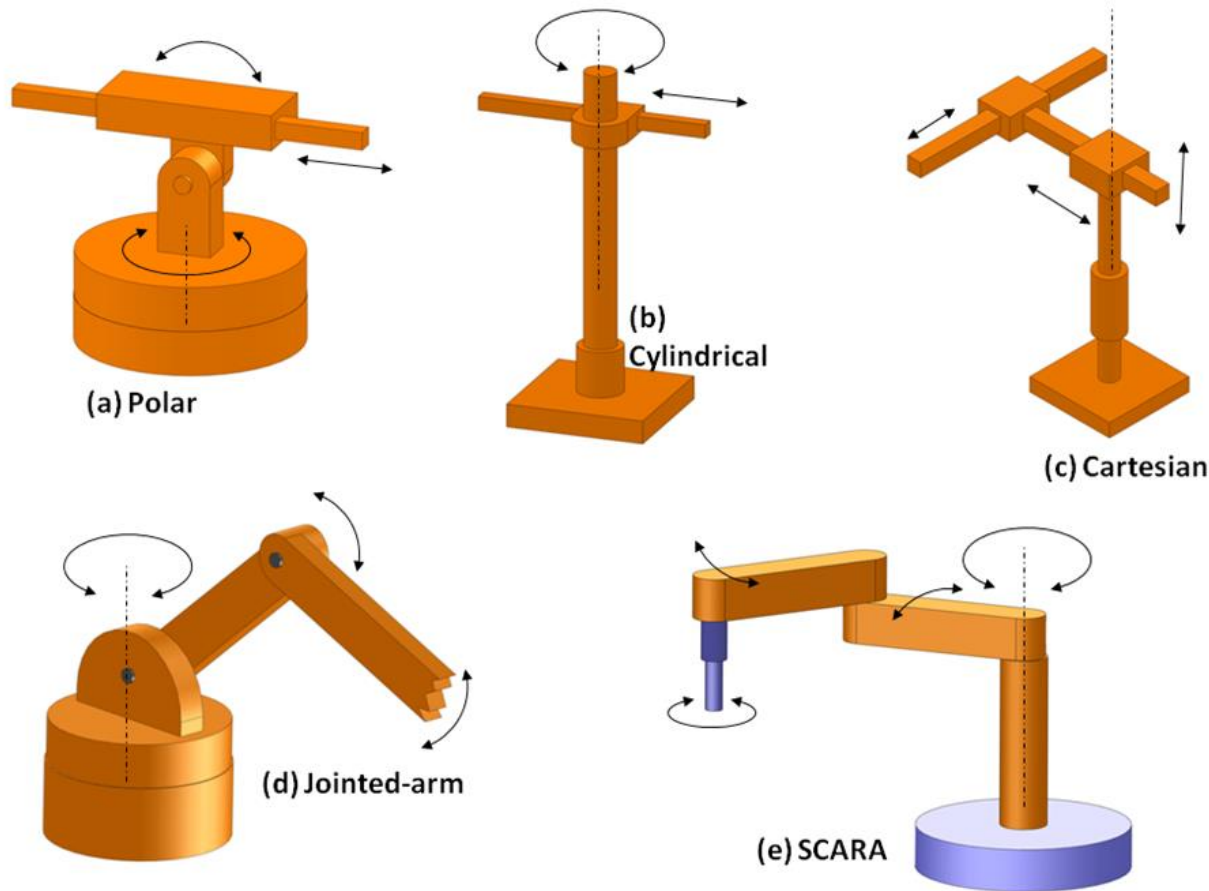

Fig. 7.5.1 Joint-link scheme for robot manipulator

Types and Classification



- Basically the robot manipulator has two parts viz. a body-and-arm assembly with three degrees-of-freedom; and a wrist assembly with two or three degrees-of-freedom.
- For body-and-arm configurations, different combinations of joint types are possible for a three-degree-of-freedom robot manipulator. Five common body-and-arm configurations are outlined in figure

a. Polar configuration



(a) Polar

- **a. Polar configuration**
- It consists of a sliding arm L-joint, actuated relative to the body, which rotates around both a vertical axis (T-joint), and horizontal axis (R-joint).

b. Cylindrical configuration

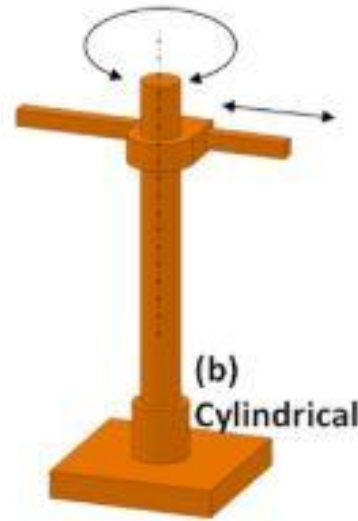

- **b. Cylindrical configuration**
- It consists of a vertical column. An arm assembly is moved up or down relative to the vertical column. The arm can be moved in and out relative to the axis of the column. Common configuration is to use a T-joint to rotate the column about its axis. An L-joint is used to move the arm assembly vertically along the column, while an O-joint is used to achieve radial movement of the arm.

C. Cartesian co-ordinate robot

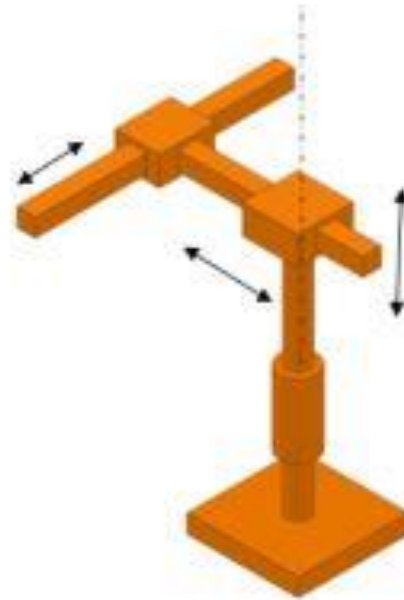

(c) Cartesian

- **c. Cartesian co-ordinate robot**
- It is also known as rectilinear robot and x-y-z robot. It consists of three sliding joints, two of which are orthogonal O-joints.

D. Jointed-arm robot

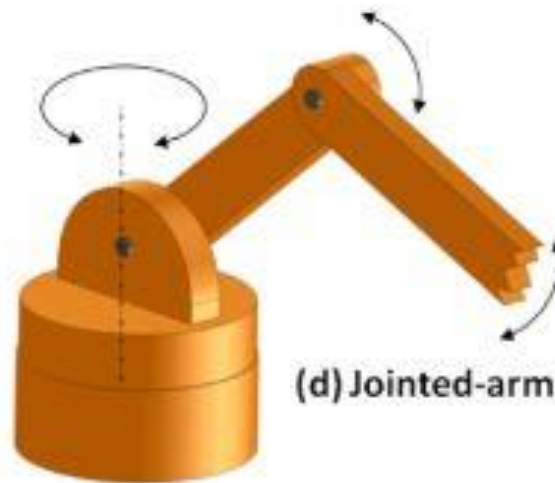

- **d. Jointed-arm robot**
- It is similar to the configuration of a human arm. It consists of a vertical column that swivels about the base using a T-joint. Shoulder joint (R-joint) is located at the top of the column. The output link is an elbow joint (another R joint).

E. SCARA

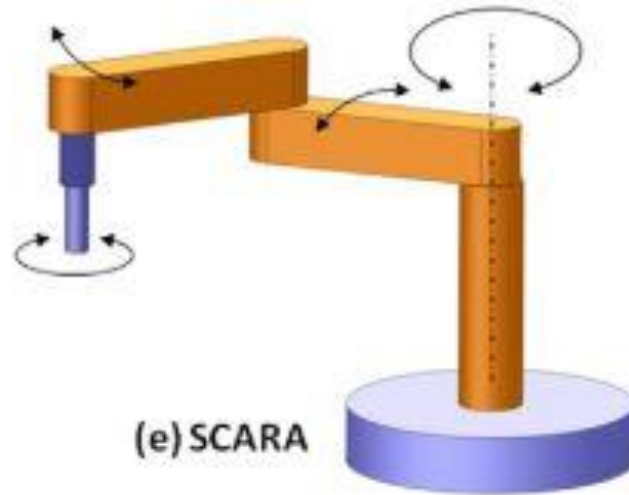

- **E. SCARA**
- Its full form is 'Selective Compliance Assembly Robot Arm'. It is similar in construction to the jointer-arm robot, except the shoulder and elbow rotational axes are vertical. It means that the arm is very rigid in the vertical direction, but compliant in the horizontal direction.

WRIST CONFIGURATION

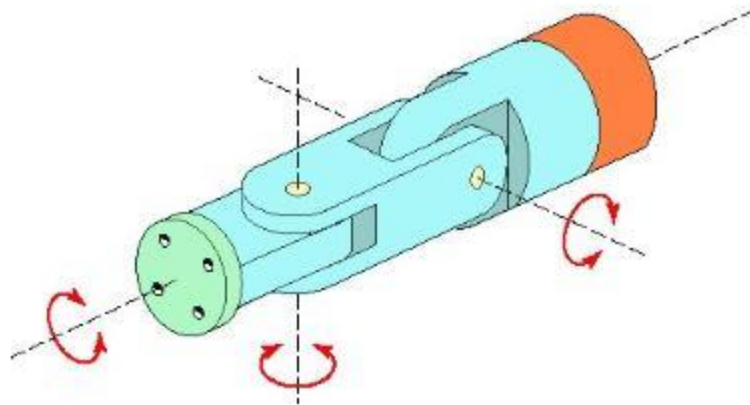
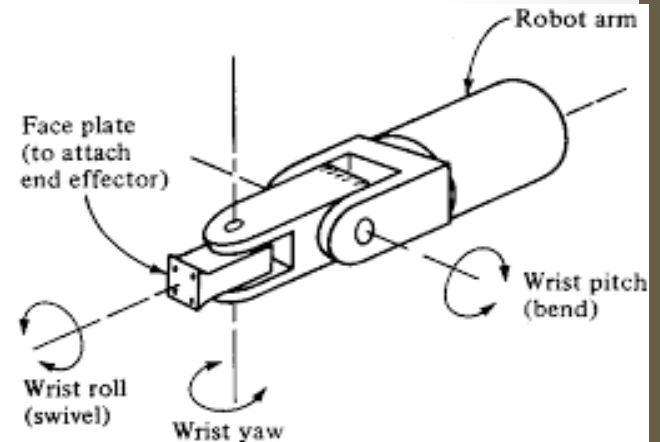

Fig. 7.5.4: Robotic wrist joint



- Robot wrist assemblies consist of either two or three degrees-of-freedom. A typical three-degree-of-freedom wrist joint is depicted in Figure 7.5.4. The roll joint is accomplished by use of a T-joint. The pitch joint is achieved by recourse to an R-joint. And the yaw joint, a right-and-left motion, is gained by deploying a second R-joint.
- The SCARA body-and-arm configuration typically does not use a separate wrist assembly. Its usual operative environment is for insertion-type assembly operations where wrist joints are unnecessary. The other four body-and-arm configurations more-or-less follow the wrist-joint configuration by deploying various combinations of rotary joints viz. type R and T.

TYPES OF JOINTS



(a) Linear Joint

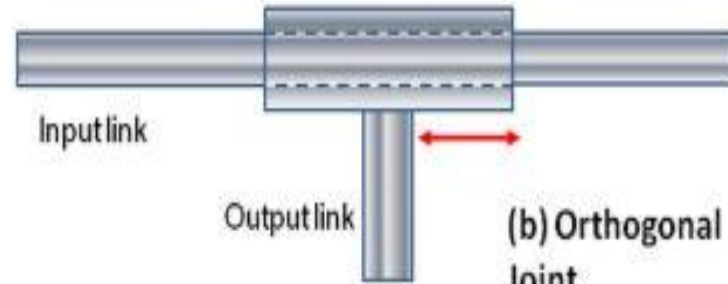

(b) Orthogonal Joint

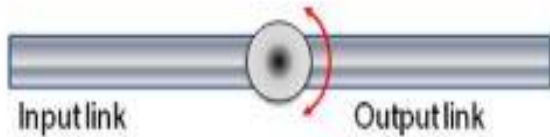

(c) Rotational Joint

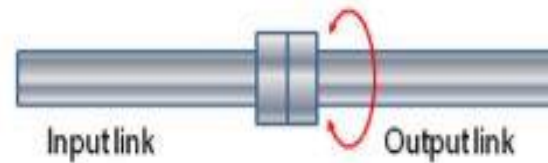

(d) Twisting Joint

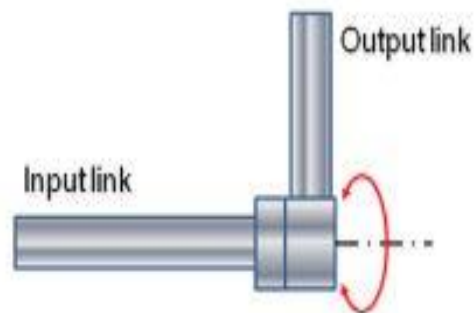

(e) Revolving Joint

Fig. 7.5.2 Types of Joints

TYPES OF JOINTS

a) Linear joint (type L joint)

The relative movement between the input link and the output link is a translational sliding motion, with the axes of the two links being parallel.

b) Orthogonal joint (type U joint)

This is also a translational sliding motion, but the input and output links are perpendicular to each other during the move.

c) Rotational joint (type R joint)

This type provides rotational relative motion, with the axis of rotation perpendicular to the axes of the input and output links.

d) Twisting joint (type T joint)

This joint also involves rotary motion, but the axis of rotation is parallel to the axes of the two links.

e) Revolving joint (type V-joint, V from the “v” in revolving)

In this type, axis of input link is parallel to the axis of rotation of the joint. However the axis of the output link is perpendicular to the axis of rotation.

WORKING OF A ROBOT

1.21. WORKING OF A ROBOT

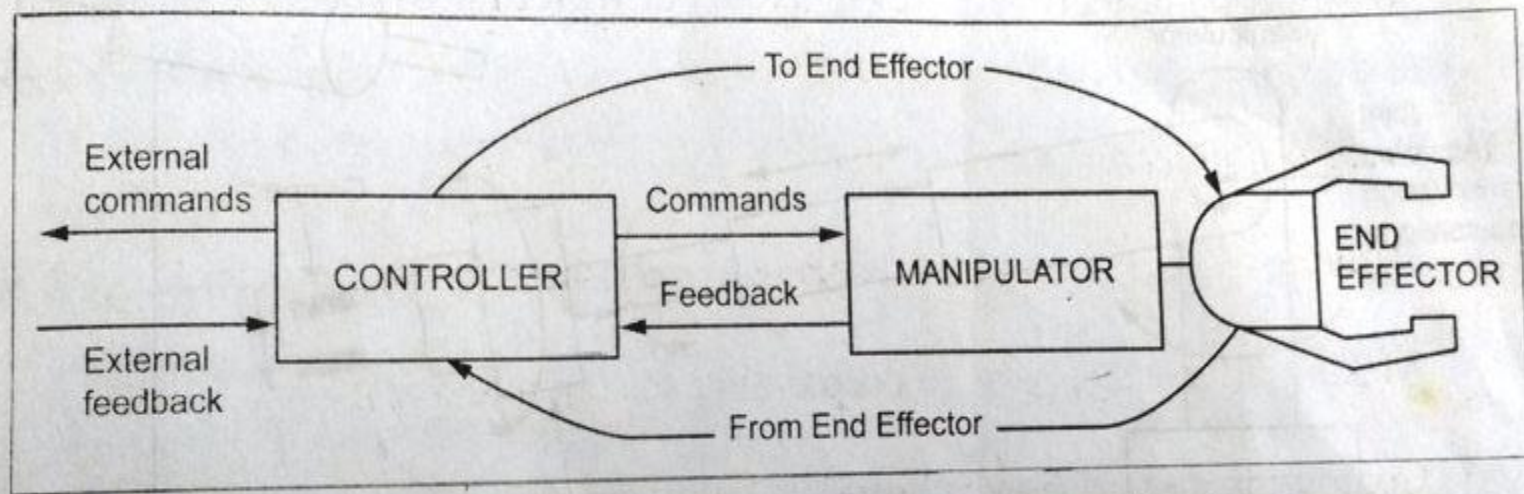

Fig. 1.27. Block diagram of welding application

ROBOT COMPONENTS

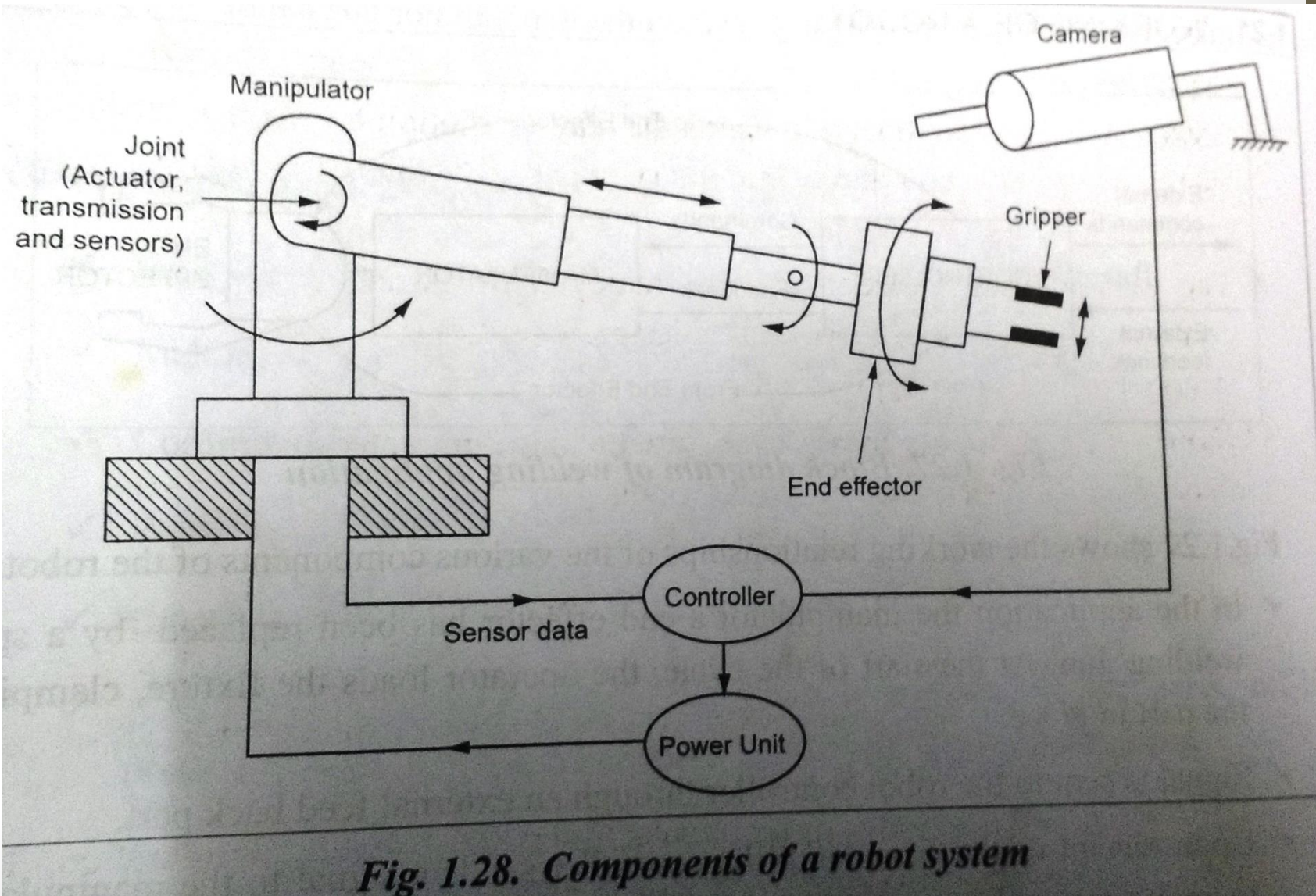

Fig. 1.28. Components of a robot system

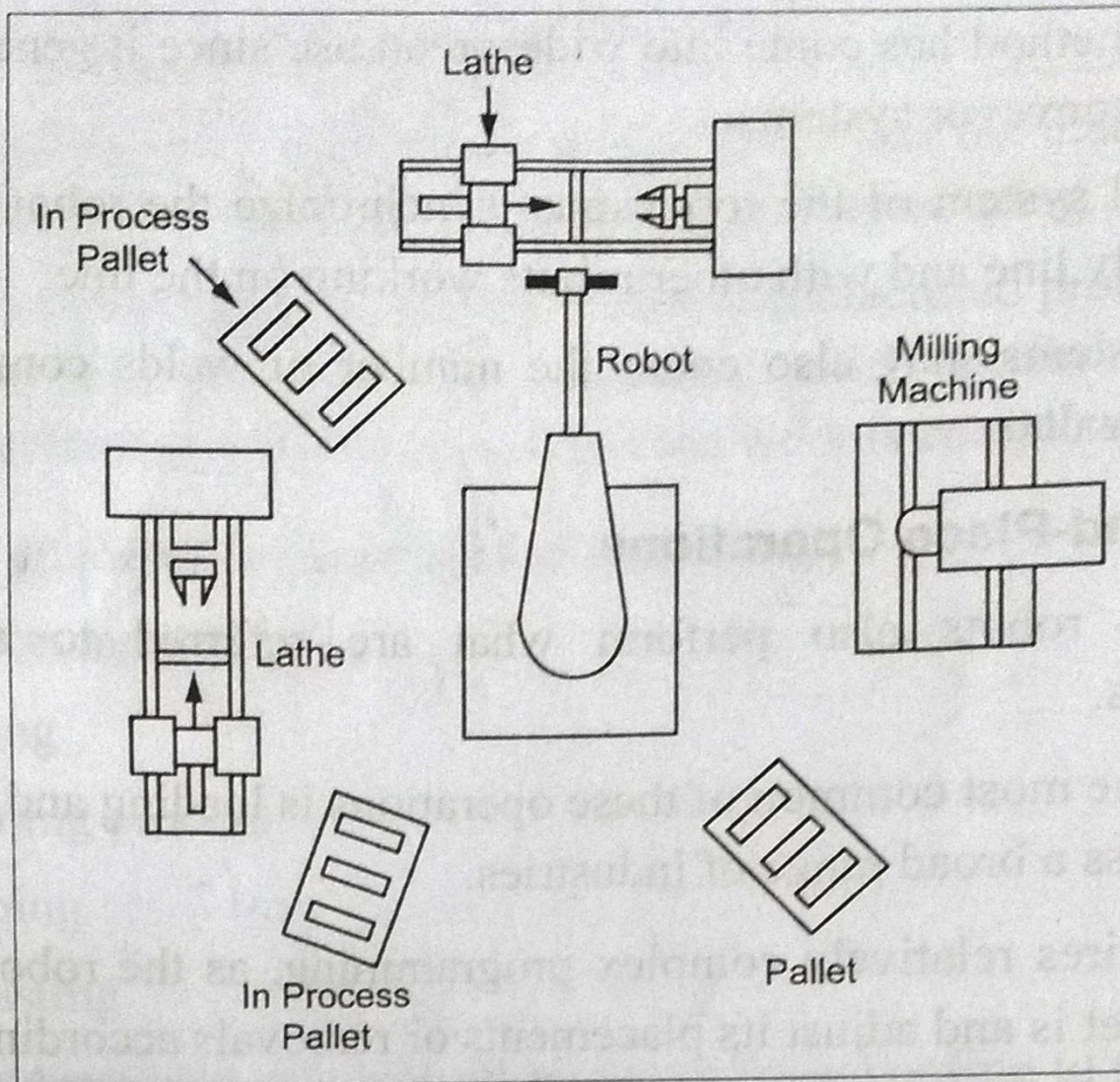

Fig. 1.22. Robotic Work Cell

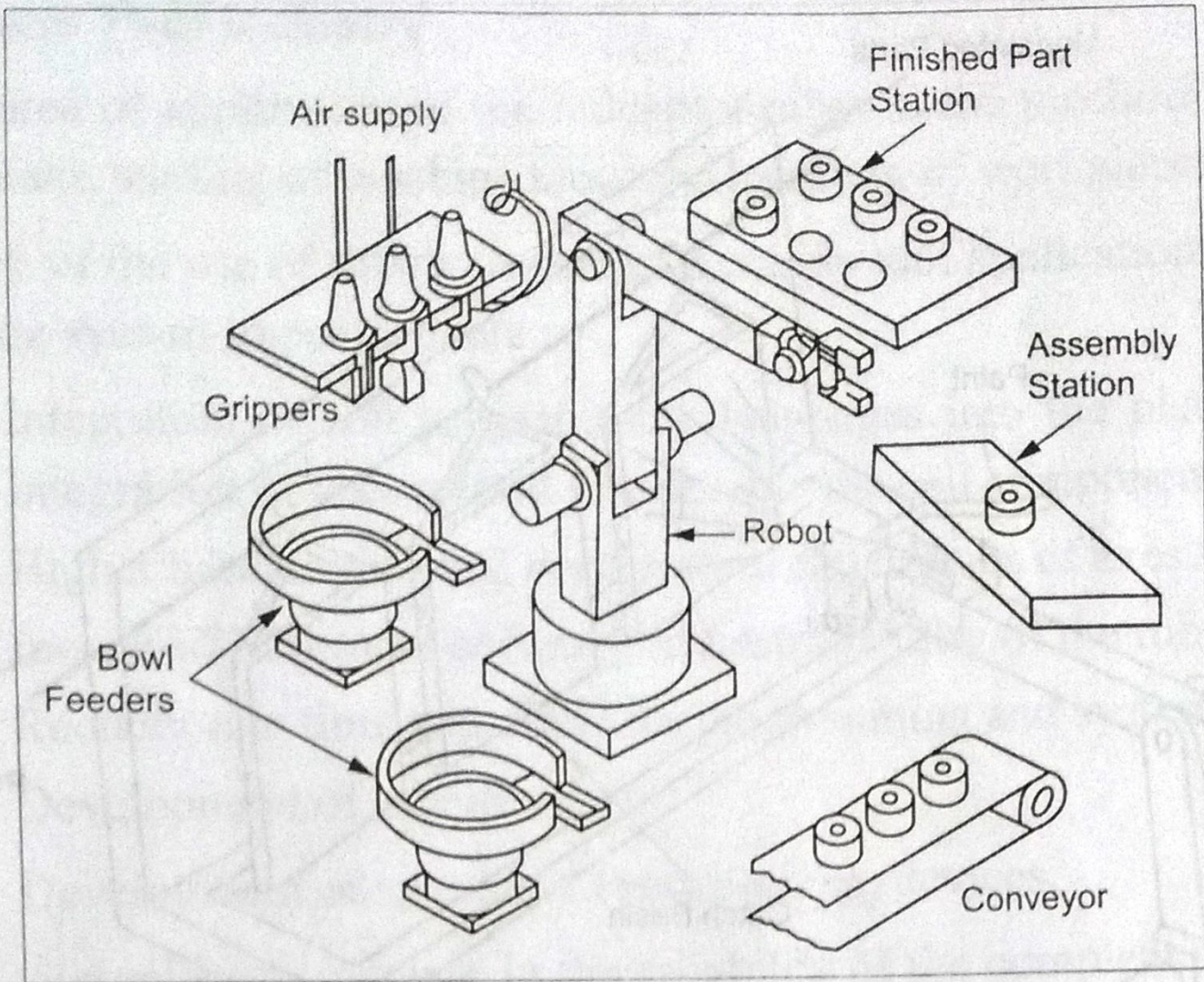

Fig. 1.24. Application of Industrial Robot in Assembly

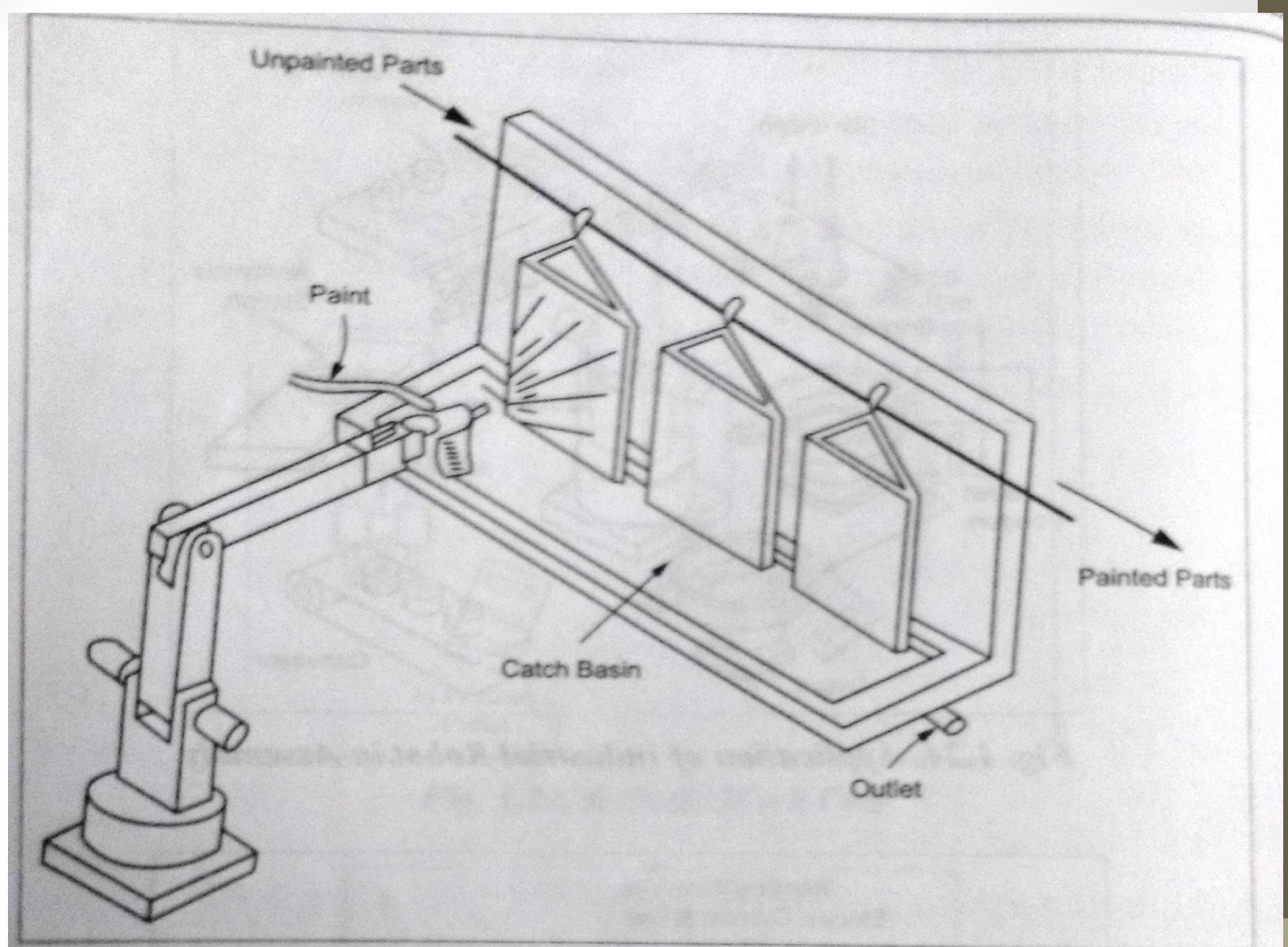

Fig. 1.26. Robot in Spray Painting

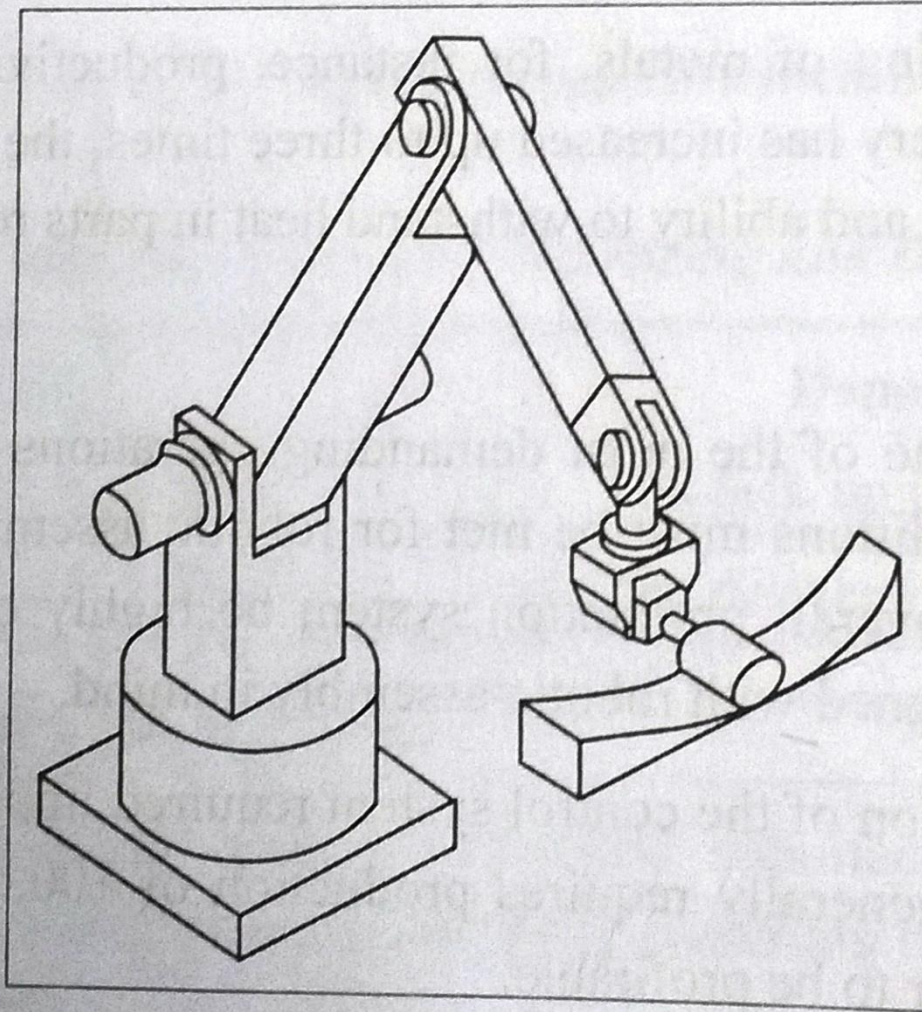

Fig. 1.23. Robot in Grinding Operation

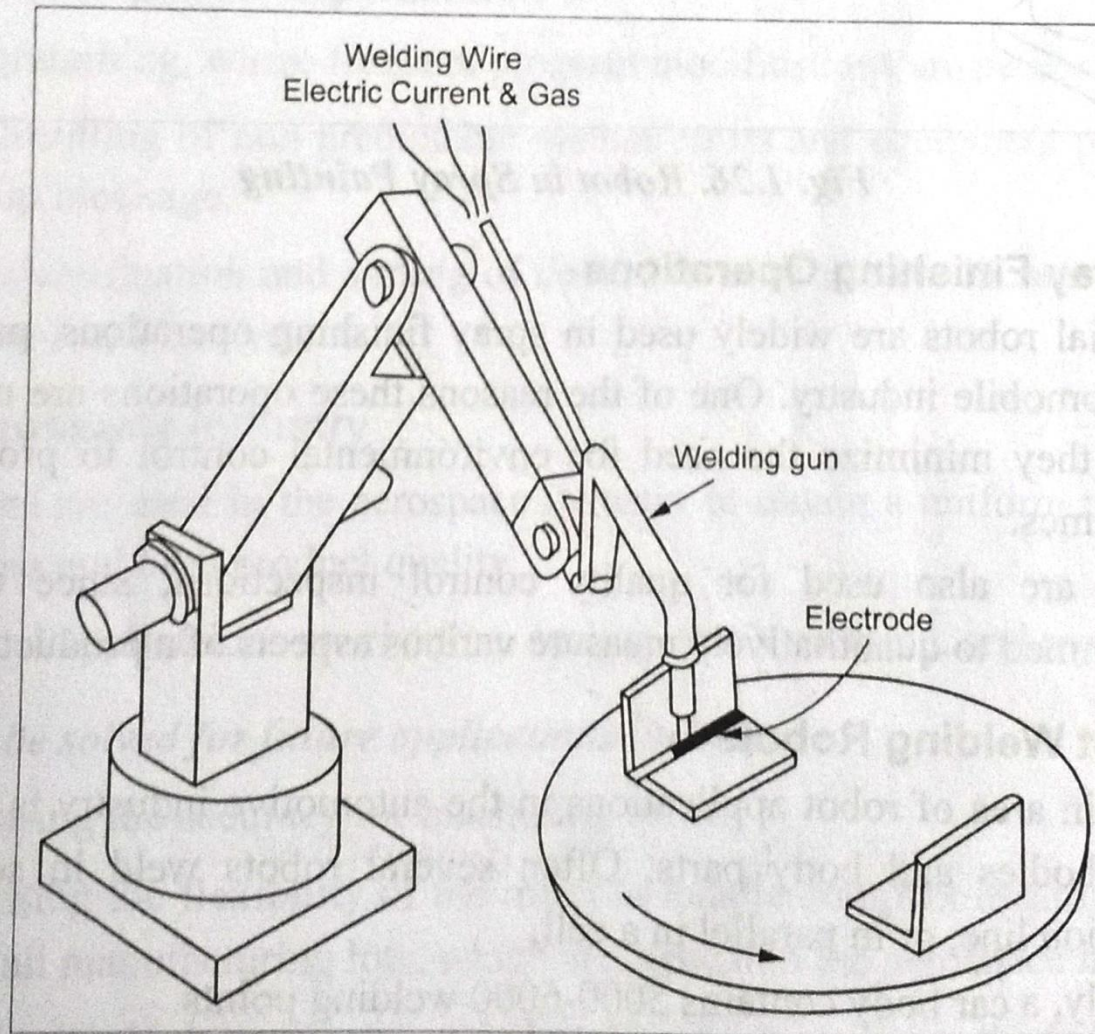

Fig. 1.25. Robot in Arc Welding

THE NEEDS OF ROBOTS

1. SPEED (Greater speed)
2. HAZARDOUS ENVIRONMENT
3. REPETITIVE TASK (Continue movement)
4. EFFICIENCY (no waste of time, materials, energy)
5. ACCURACY ()
6. ADAPTABILITY

(control changes in car welding areas, ability to work fast, ability to work in hazardous environment, ability to repeat the task again and again)

CLASSIFICATION OF ROBOTS

1. Physical Configuration
2. Control system
3. Movement
4. Types of drive
5. Application
6. Degrees of freedom
7. Sensory system
8. Capabilities of Robot Systems

1. Physical Configuration

1. Polar Configuration
2. Cylindrical Configuration
3. Cartesian Configuration
4. Jointed arm Configuration

2. Control Systems

Point to Point

Straight line robot

Continuous robot

3. Movements

Fixed robot

Mobile robot

Walking robot or legged robot

4. Types of drive

Pneumatic Drive

Hydraulic drive

Electric drive

5. Application

Manufacturing

Handling

Testing

6. Degrees of Freedom

1, 2, 3 six

7. Sensory system

- ✓ Simple and blind robot
- ✓ Vision Robot
- ✓ Intelligent

8. Capabilities of Robot Systems

- ✓ External Robot control and communication
- ✓ System parameters
- ✓ Program control
- ✓ Control of the end effector
- ✓ Program debug and simulation
- ✓ Ability to move between points in various ways

Service Industry And Other Applications:

- Teaching robots ·
- Retail robots ·
- Fast-food restaurants ·
- Garbage collection in waste disposal operations ·
- Cargo handling and loading and distribution operations ·
- Security guards ·
- Medical care and hospital duties ·
- Agricultural robots · House hold robots

UNIT II ROBOT DRIVE SYSTEMS AND END EFFECTORS

- Pneumatic Drives-Hydraulic Drives-Mechanical Drives-Electrical Drives-D.C. Servo Motors, Stepper Motors, A.C. Servo Motors-Salient Features, Applications and Comparison of all these Drives,
- EndEffectors-Grippers-Mechanical Grippers, Pneumatic and Hydraulic- Grippers, Magnetic Grippers, Vacuum Grippers; Two Fingered and Three Fingered Grippers; Internal Grippers and External Grippers; Selection and Design Considerations.

End Effectors & Grippers

End Effectors

- An end effector is usually attached to the robot's wrist, and it **allows the robot to accomplish a specific task.**
- This means that end effectors are generally custom-engineered and fabricated for each different operation.
- There are two general categories of end effectors viz. **grippers and tools.**

Mechanical gripper

- A mechanical gripper is used as an *end effector* in a robot for grasping the objects with its *mechanically* operated fingers.
- In industries, two fingers are enough for holding purposes. More than three fingers can also be used based on the application. As most of the fingers are of *replaceable* type, it can be easily removed and replaced.

- In a mechanical gripper, the holding of an object can be done by *two different methods* such as:
- Using the finger pads as like the shape of the work part.
- Using soft material finger pads.

Gripper

End-effector that holds or grasp an object (in assembly, pick and place operation and material handling) to perform some task.

Four Major Types of gripper

1. Mechanical
2. Suction or vaccum cups
3. Magnetised gripper
4. Adhesives

Mechanical Gripper

- It is an end effector that uses mechanical fingers actuated by a mechanism to grasp an object.

Two ways of constraining part in gripper

- Physical construction of parts within finger. Finger encloses the part to some extent and thereby designing the contact surface of finger to be in approximate shape of part geometry.
- Holding the part is by friction between fingers and workpart. Finger must apply force that is sufficient for friction to retain the part against gravity.

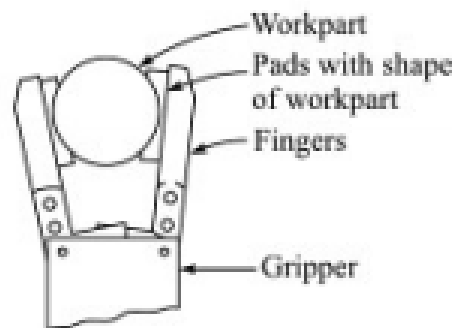

Fig. 5.2 *Physical constriction method of finger design.*

Mechanical Gripper

- To resist the slippage, the gripper must be designed to exert a force that depends on the weight of the part, coeff of friction and acceleration of part.

$$\mu n_f F_g = w \quad (5.1)$$

where μ = coefficient of friction of the finger contact surface against the part surface

n_f = number of contacting fingers

F_g = gripper force

w = weight of the part or object being gripped

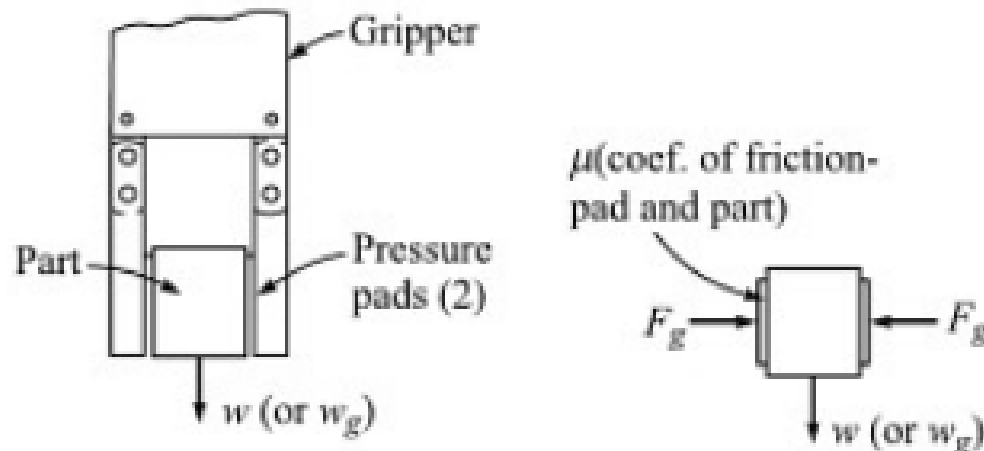

Mechanical Gripper Mechanism

Two ways of gripper mechanism based on finger movement

1. Pivoting movement – Eg. Link actuation
2. Linear or translational movement – Eg. Screw and cylinder

Four ways of gripper mechanism based on kinematic devices

1. Linkage actuation
2. Gear and rack actuation
3. Cam actuation
4. Screw actuation

Mechanical Gripper Mechanism

1. Linkage actuation

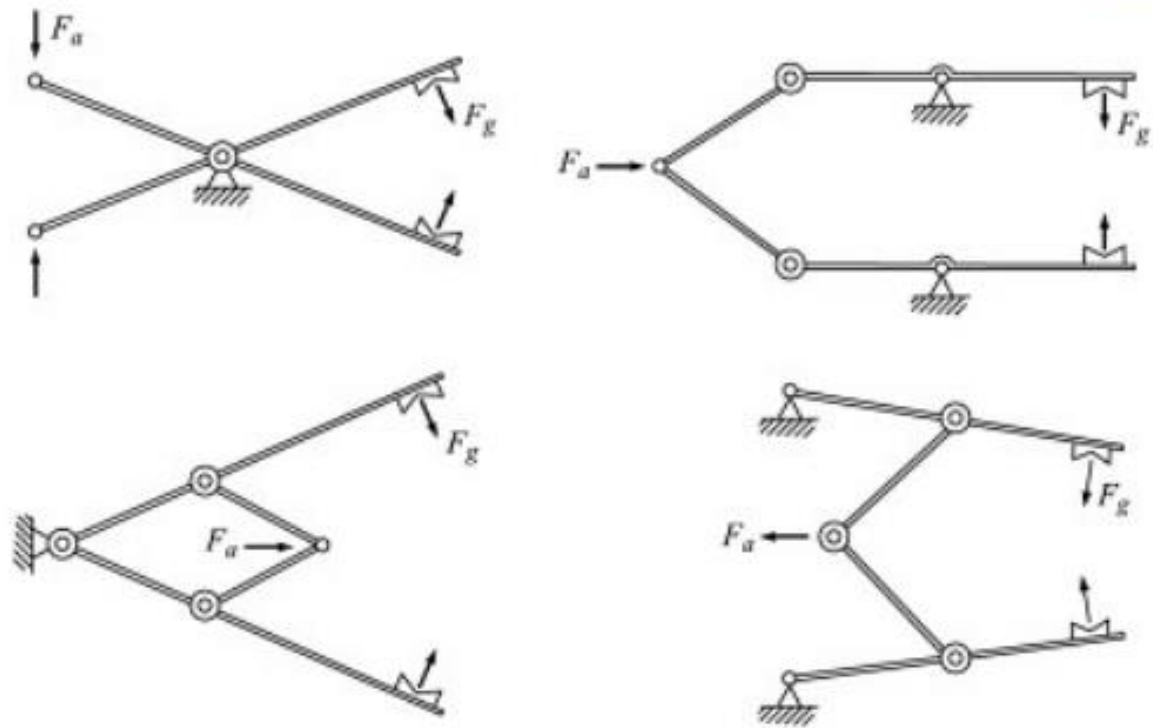

Some possible linkages for robot grippers.

Mechanical Gripper Mechanism

2. Gear and rack actuation

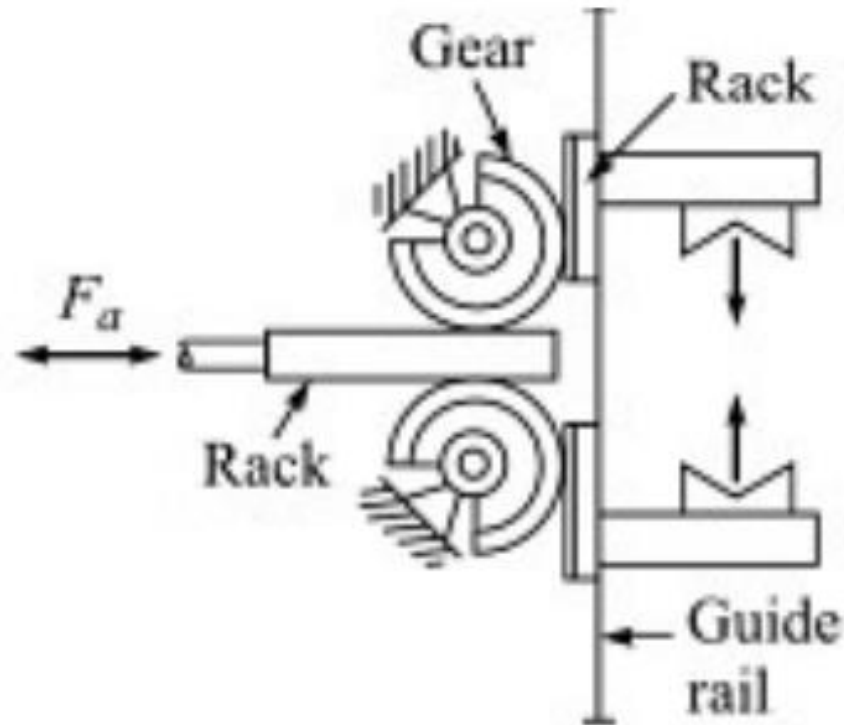

Gear-and-rack method of actuating the gripper.

Mechanical Gripper Mechanism

3. Cam actuation

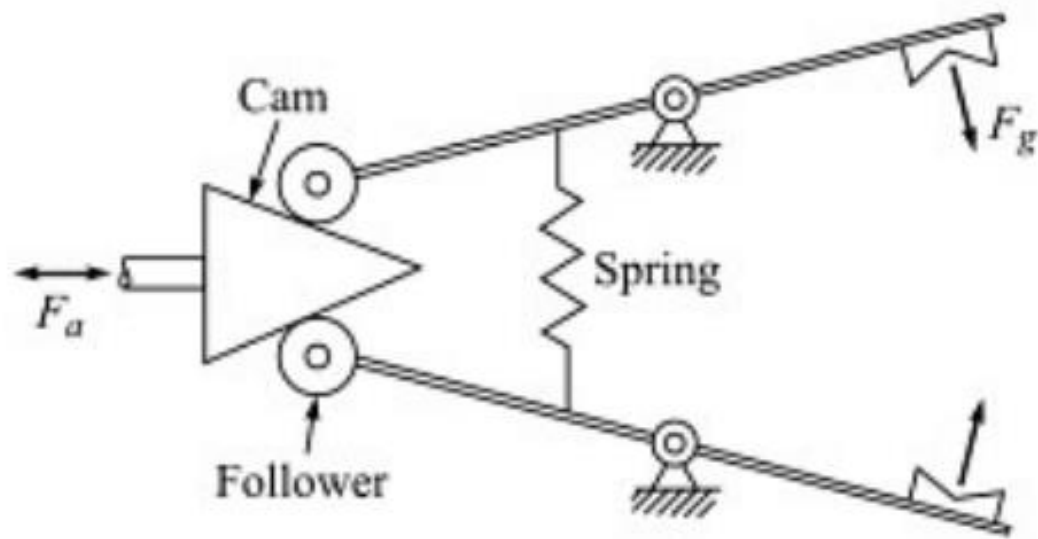

Cam-actuated gripper.

Mechanical Gripper Mechanism

4. Screw actuation

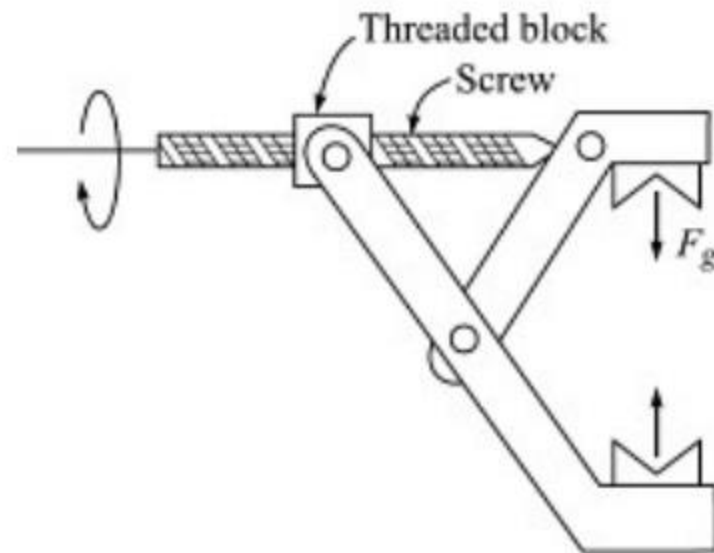

Screw-type gripper actuation.

Pneumatic or air operated Gripper

- Equipped with roller membrane cylinder with a rolling motion replacing conventional piston cylinder.
- This motion is transmitted to fingers by means of lever mechanism.
- The grippers are actuated by switching valves in the circuit.
- The finger stroke is limited by end stops or workpiece to be gripped.

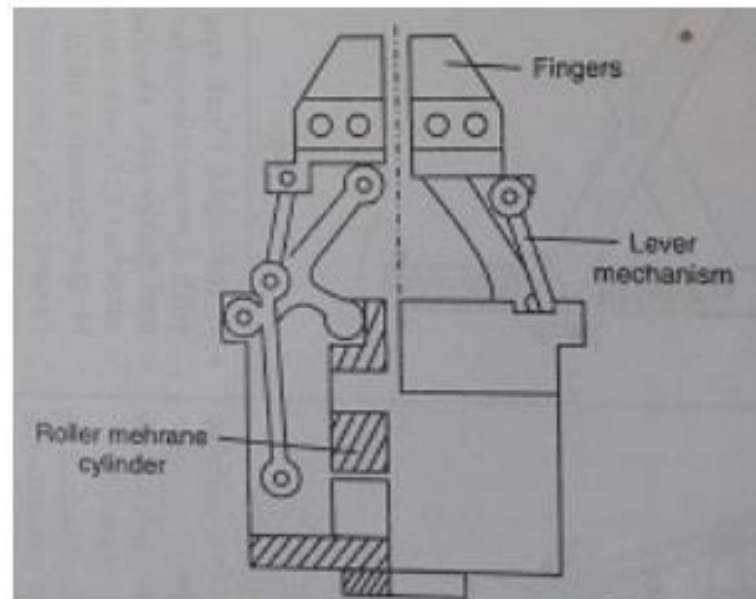

Internal & External Grippers

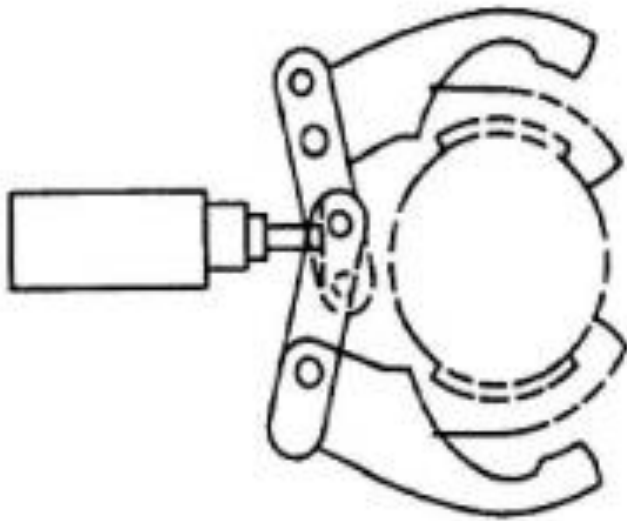

Figure 1 External gripper.

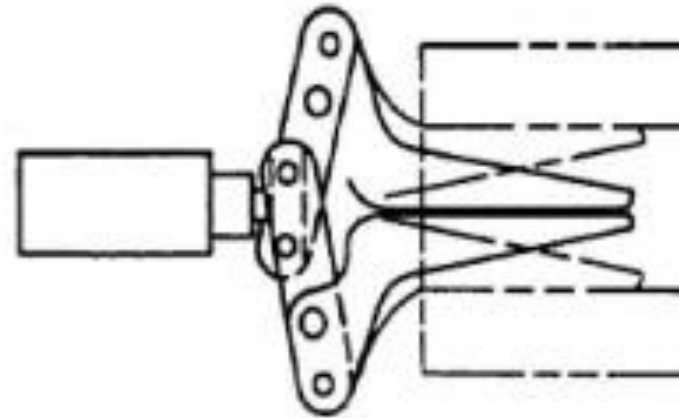

Figure 2 Internal gripper.

- In the first method, the contact surfaces of the fingers are designed according to the work part for achieving the *estimated shape*. It will help the fingers to hold the work part for some extent.
- In the second method, the fingers must be capable of supplying sufficient force to hold the work part. To avoid scratches on the work part, *soft type pads* are fabricated on the fingers.

- As a result, the contact surface of the finger and co – efficient of friction are improved. This method is very simple and as well as *less expensive*. It may cause slippage if the force applied against the work part is in the parallel direction. The slippage can be avoided by designing the gripper based on the force exerted.

- $$\mu n_f F_g = w \quad \dots\dots\dots 1$$

- μ => co – efficient of friction between the work part and fingers

- n_f => no. of fingers contacting

- F_g => Force of the gripper

- w => weight of the grasped object

- The equation 1 must be *changed* if the weight of a work part is more than the force applied to cause the slippage.

- $$\mu n_f F_g = w g \quad \dots\dots\dots 2$$

- g => g factor

- During rapid grasping operation, the work part will get *twice* the weight. To get rid out of it, the modified equation 1 is put forward by *Engelberger*. The g factor in the equation 2 is used to calculate the acceleration and gravity.

- The *values of g factor* for several operations are given below:

- $g = 1$ – acceleration supplied in the opposite direction.

- $g = 2$ – acceleration supplied in the horizontal direction.

- $g = 3$ – acceleration and gravity supplied in the same direction.

Mechanical Gripper Mechanism

1. Linkage actuation

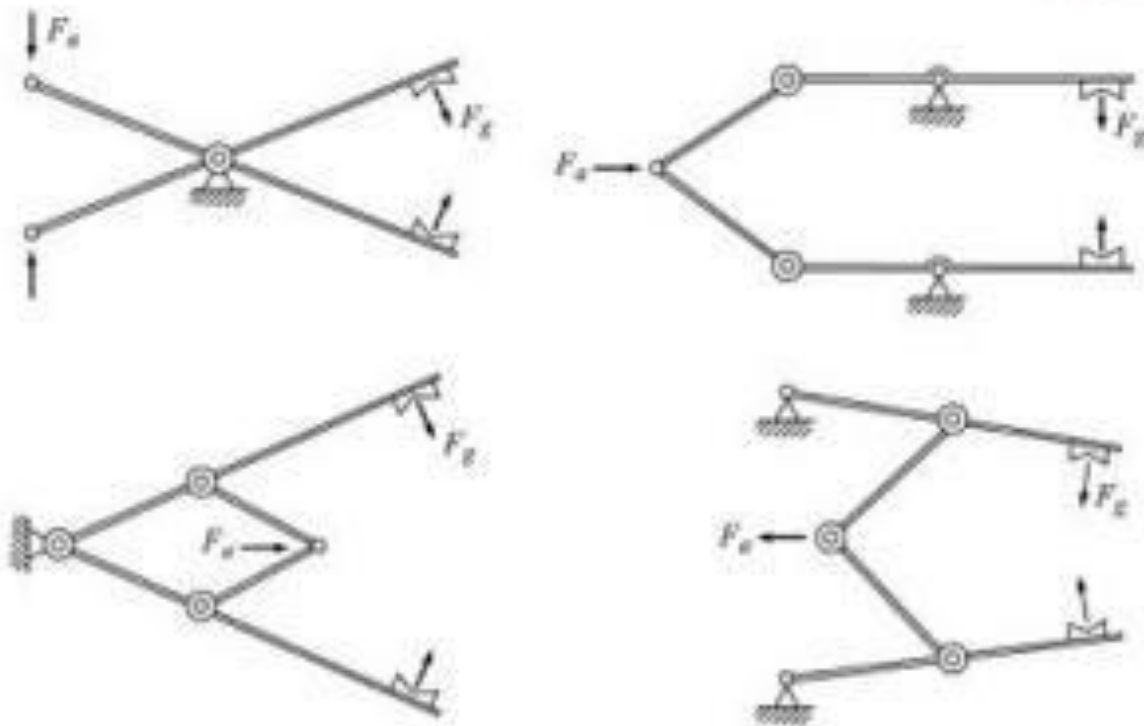

Some possible linkages for robot grippers.

Screw actuation:

- The screw-type actuated gripper consists of a *screw* connected with a *threaded block*. To rotate the screw, a motor is used along with a speed reduction device. If the screw is turned in one direction, the threaded block is moved in one direction. Similarly, the threaded block moves in the opposite direction if the screw is turned on the other direction. As the threaded block is attached with gripper, it makes the fingers to open and close.

Mechanical Gripper Mechanism

2. Gear and rack actuation

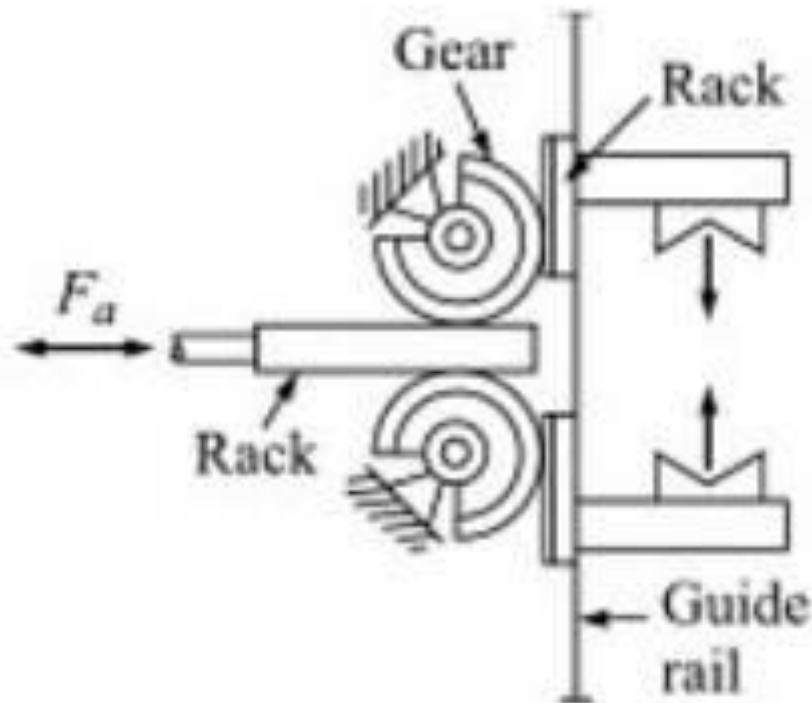

Gear-and-rack method of actuating the gripper.

Gear and rack actuation:

- For this actuation, the gear and rack are connected with a *piston*, which provides *linear-type movement*. The two partial pinion gears are driven when the rack is moved. As it is linked with gripper, the opening and closing of fingers are accomplished.

Mechanical Gripper Mechanism

4. Screw actuation

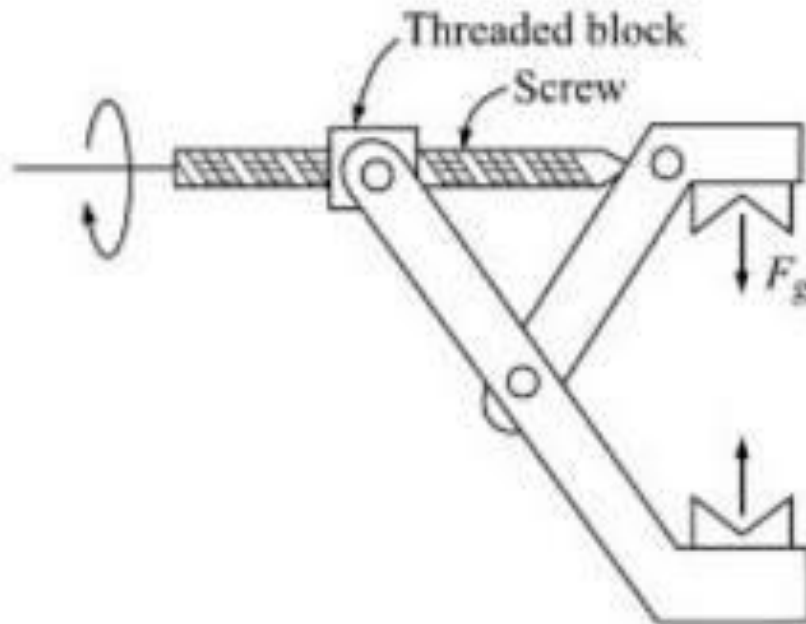

Screw-type gripper actuation.

Pivoting or Swinging Gripper Mechanisms:

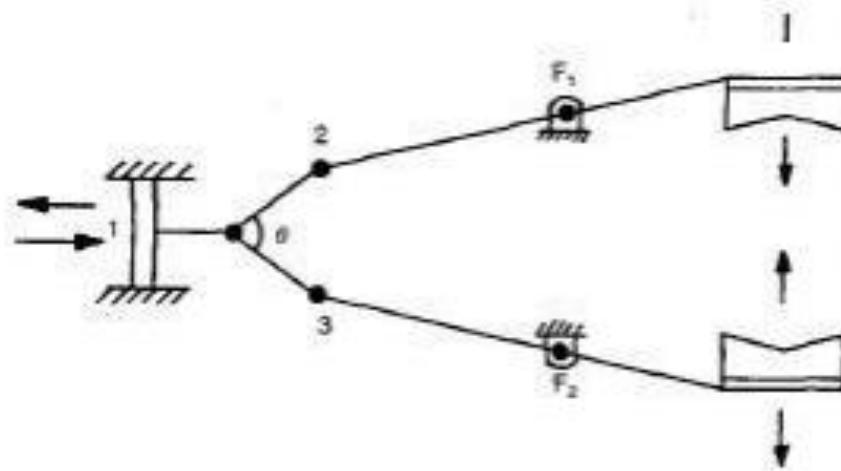

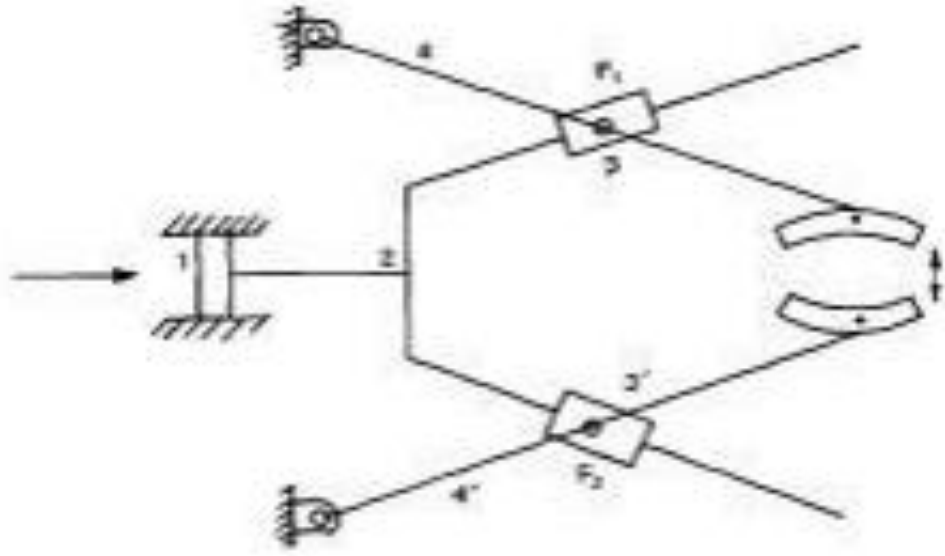

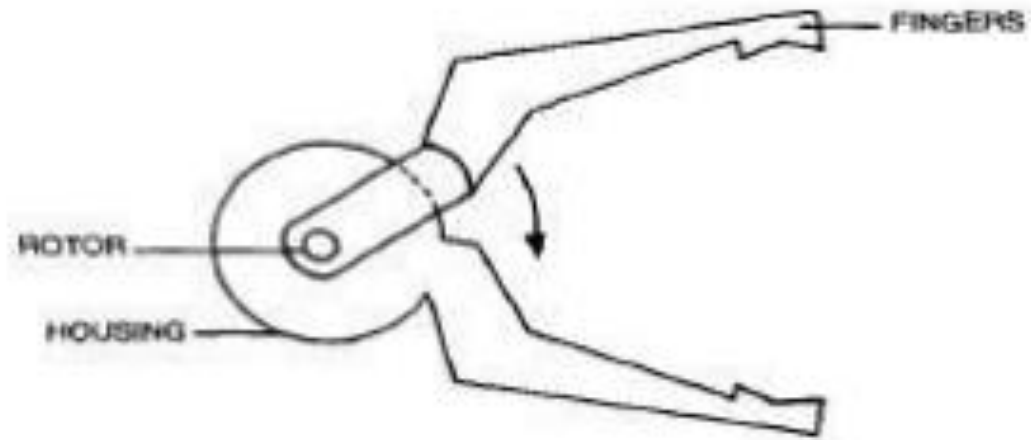

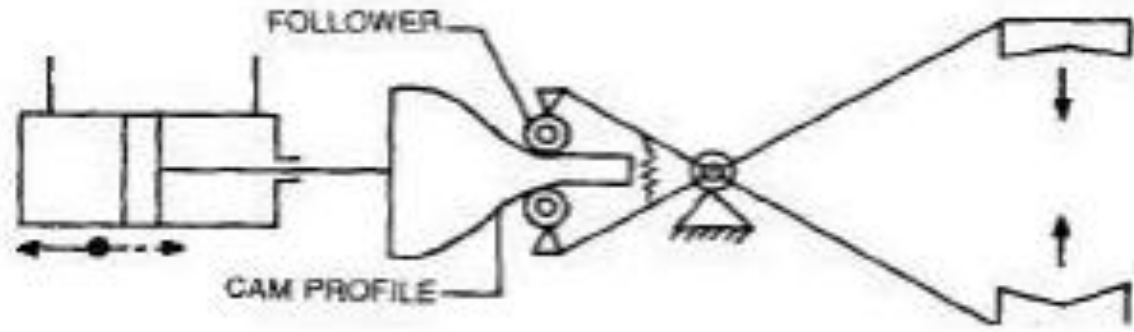



Robot Mechanical Gripper

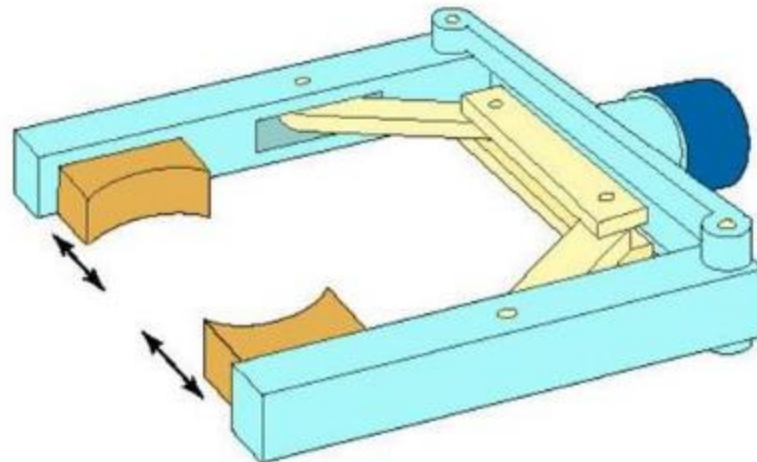

- A two-finger mechanical gripper for grasping rotational parts

Pneumatic Grippers

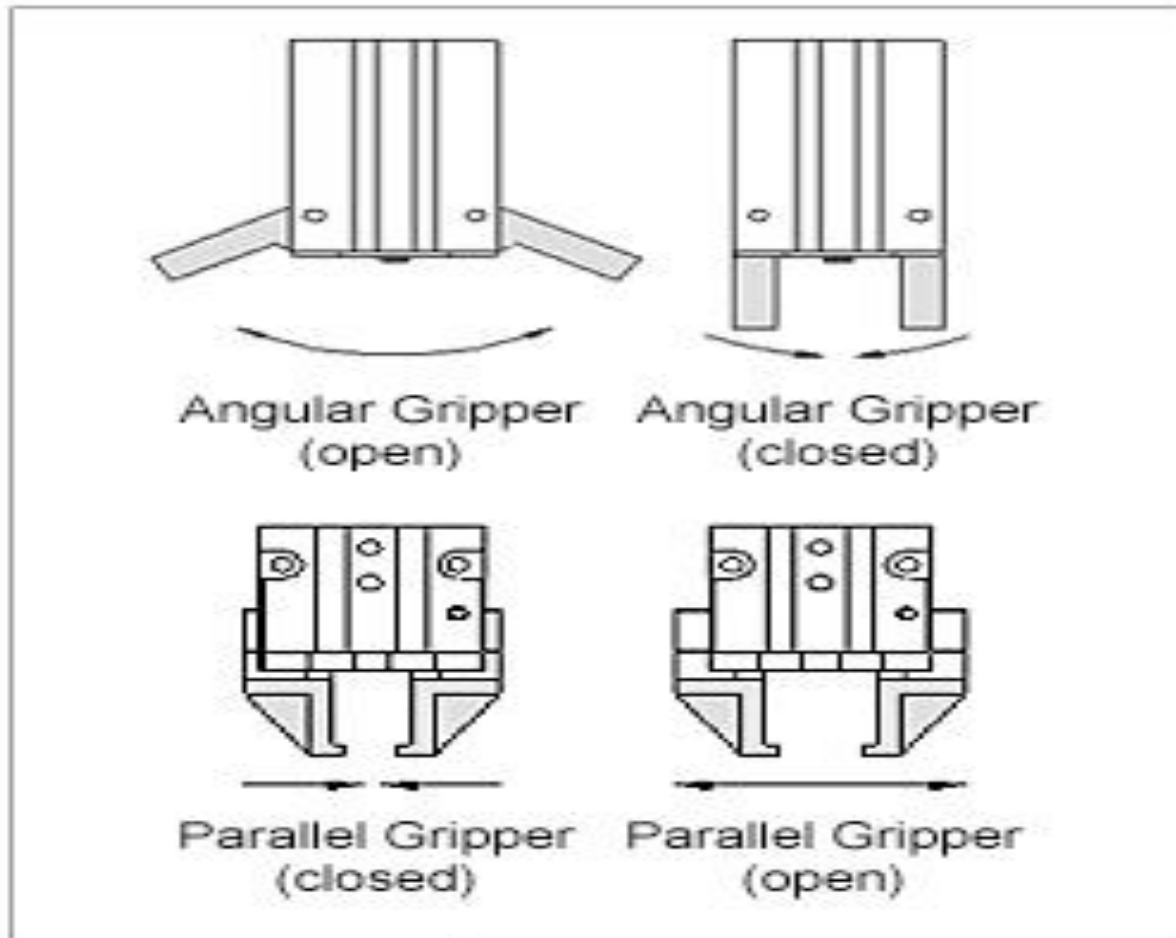

Types of Grippers

Magnetized grippers:

- Magnetic grippers are be divided into 2 types:
- I . Electro magnetic
- ii. Permanent magnetic.

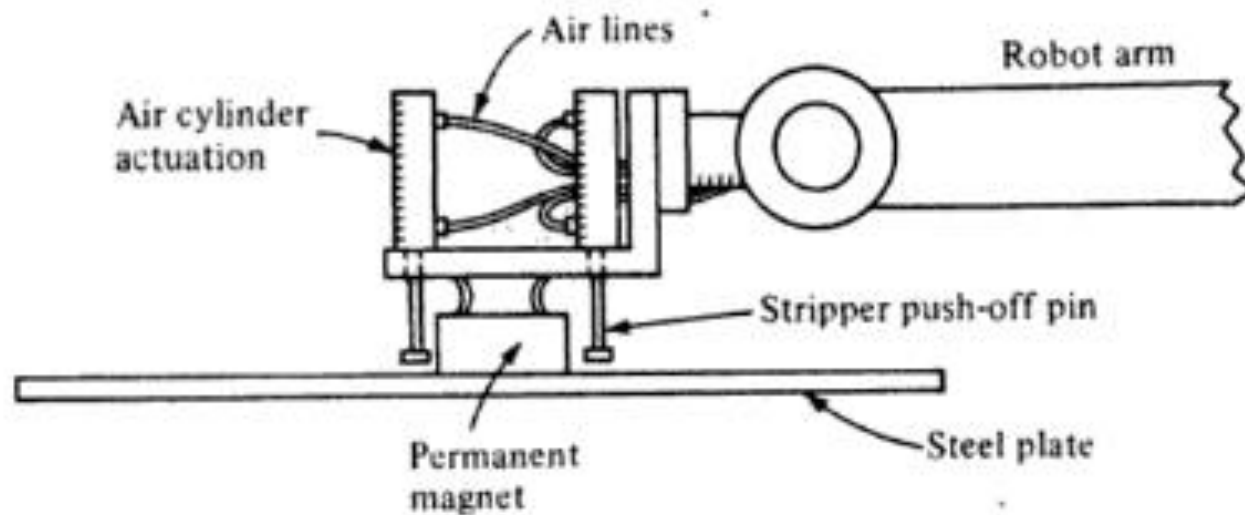

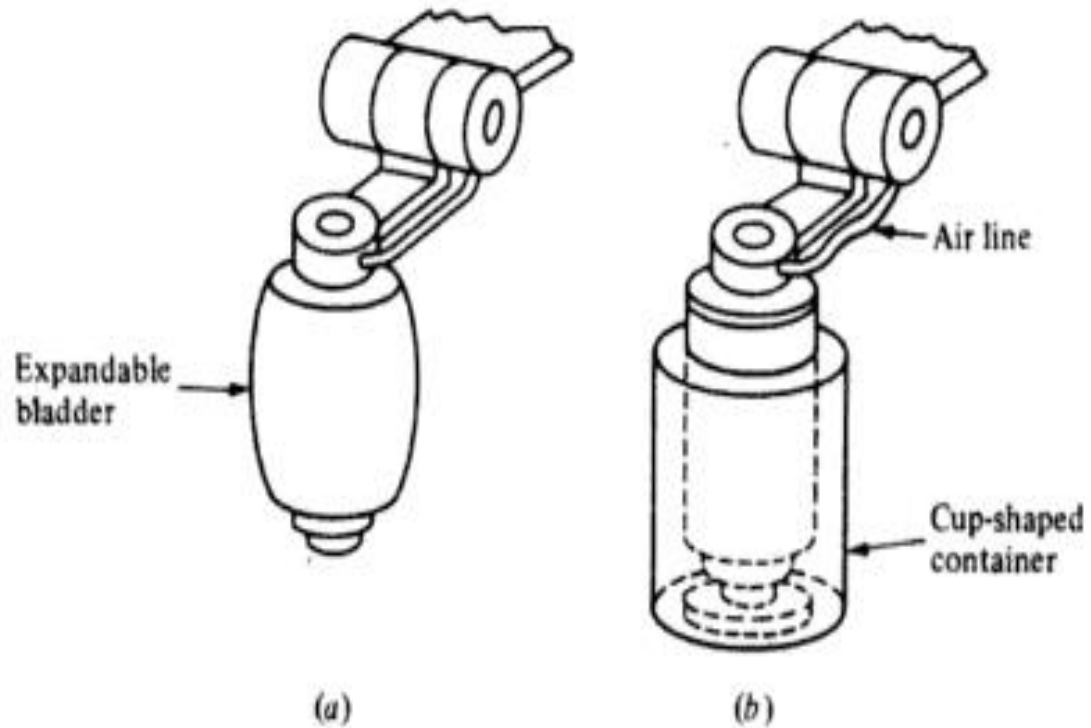

Figure 5-16 Expansion bladder used to grasp inside of a cup-shaped container.

Table 5-1 Checklist of factors in the selection and design of grippers

Factor	Consideration
Part to be handled	Weight and size Shape Changes in shape during processing Tolerances on the part size Surface condition, protection of delicate surfaces
Actuation method	Mechanical grasping Vacuum cup Magnet Other methods (adhesives, scoops, etc.)
Power and signal transmission	Pneumatic Electrical Hydraulic Mechanical
Gripper force (mechanical gripper)	Weight of the object Method of holding (physical constriction or friction) Coefficient of friction between fingers and object Speed and acceleration during motion cycle
Positioning problems	Length of fingers Inherent accuracy and repeatability of robot Tolerances on the part size

Positioning problems	<ul style="list-style-type: none"> Length of fingers Inherent accuracy and repeatability of robot Tolerances on the part size
Service conditions	<ul style="list-style-type: none"> Number of actuations during lifetime of gripper Replaceability of wear components (fingers) Maintenance and serviceability
Operating environment	<ul style="list-style-type: none"> Heat and temperature Humidity, moisture, dirt, chemicals
Temperature protection	<ul style="list-style-type: none"> Heat shields Long fingers Forced cooling (compressed air, water cooling, etc.) Use of heat-resistant materials
Fabrication materials	<ul style="list-style-type: none"> Strength, rigidity, durability Fatigue strength Cost and ease of fabrication Friction properties for finger surfaces Compatibility with operating environment
Other considerations	<ul style="list-style-type: none"> Use of interchangeable fingers Design standards Mounting connections and interfacing with robot Risk of product design changes and their effect on the gripper design Lead time for design and fabrication Spare parts, maintenance, and service Tryout of the gripper in production

The drive:

The drive is the engine that moves the articulations into their designated positions. The joints are the sections between the parts of the robot. The following types of units are:

hydraulic, electric, or pneumatic.

- o Hydraulic drive systems give a robot great speed and strength.
- o Electric system provides a robot with less speed and strength.
- o Pneumatic drive systems are used for smaller robots that have fewer axes of movement.

Cam actuation

- As like linkage actuated gripper, it also has a wide range of designs for opening and closing the gripper fingers. One of its types is described shortly here. A cam actuated gripper with *spring loaded follower* can be used to provide open and close actions of fingers. The spring is incorporated for forcing the gripper to close if the cam is moved in one direction, while the movement of cam on the other direction causes the gripper to open. This type can be useful for holding *various sizes of work parts*.

Rope and pulley actuation:

- In this actuation, a *tension device* is required to go up against the rope movement in the pulley. Suppose, if the pulley is activated in one direction for opening the gripper, the tension device will provide *slack* in the rope. Similarly, the gripper is closed by activating the pulley on the other direction.

- Additionally, some mechanisms come under miscellaneous types. An important one is *diaphragm or expandable bladder*, which is inflated or deflated to open and close the fingers.

Pneumatic Grippers

- The most popular types of pneumatic grippers are the 2 jaw parallel and 2 jaw angular gripper styles. Parallel grippers open and close parallel to the object that it will be holding, these are the most widely used grippers. They are the simplest to tool and can compensate for some dimensional variation.
- Angular grippers move the jaws in a radial manner to rotate the jaws away from the object and therefore require more space. There are also 3 jaw and toggle style grippers that are designs for more specific handling requirements.

Hydraulic Grippers

- Grippers are devices used with pick-and-place robotic systems to pick up or place an object on an assembly line, conveyor system, or other automated system. Fingered tooling—or jaws—is attached to the grippers to grip or hold the object.
- Three common types are parallel, three-finger, and angled designs. The most common are parallel designs, with two fingers that close on a workpiece to grip it or open it out by creating pressure on the inside. Three-finger designs hold the workpiece in the center, and have three fingers offset by 120° . Finally, angled designs feature jaws that work at a variety of different angle openings (for example, 30° , 40° , etc.).

- In general, hydraulic and pneumatic grippers have the same basic actuation principle. They include direct acting piston designs as well as piston wedge designs.
- The direct acting piston design is used when a hydraulic force acts directly on a piston that is directly connected to the jaw or finger that is touching or gripping the part.

- The piston wedge design features a hydraulic force acting on a piston while the piston itself is acting on a wedge. The wedge translates this force to the jaws or fingers, providing the grip force to grip the part.
- The wedge can give a mechanical advantage as it can increase grip force while keeping the piston diameter and pressure to the piston the same. This allows more grip force in a smaller package compared to the directing piston.

- In addition, three choices of power are available; the most common being pneumatic grippers; electromechanical grippers are second most common; and the least common being hydraulic grippers. Hydraulic grippers are most often used in conjunction with a piece of equipment that only has a hydraulic power source for actuators.

- When selecting a hydraulic gripper, it is important to consider the following:
- Part weight and size to be lifted
- Part material
- Clearance issues around the part that could interfere with the gripping part
- The environment the gripper will be used in (corrosive, food or beverage, etc.)
- The motion path of the robot or linear device that is moving the gripper
- The power supply that will be available and the pressure ratings available

- There are different types of robot end effectors. The most common are pneumatic grippers, because they are simple and low cost. Nowadays, a new player has entered the game and it is the electric gripper. This kind of gripper allows the user to control precisely the speed and position of the end effector. Suction cups are even more simple gripping devices since they use vacuum to lift flat objects. Then comes the magnetic gripper. This gripper is often forgotten in grippers lists, so we decided to expose you to its characteristics.

Magnetic end effector types

- **Electromagnets**
- Grippers using electromagnets are generally powered by DC power for handling material. This type of magnetic end effector is easy to control because the attraction can be turned off by shutting down the current. This can also help to remove the magnetism of the handled part.

- **Permanent Magnets**

- These kinds of end effectors do not need power to operate. They are always on. In order to separate the piece from the magnet, a push-off pin is included on the end effector. The permanent magnet offers an advantage when it comes to safety, since the gripper remains on even if a blackout occurs. Moreover, there is no possibility of generating sparks during production since no electric current is required.

- **Top 5 advantages**

- It only needs one surface to grab the object.
- The grasping speed is fast.
- It is flexible since it does not need different designs for different parts.
- It can grip parts with holes which is not possible with vacuum grippers.
- It requires minimal maintenance.

- **Top 5 disadvantages**

- When moved quickly, the part can slip out of the end effector.
- Just a little oil on the surface can reduce the strength of the end effector.
- Machining chips can stay on the gripper when unloading the piece.
- Handled parts can stay magnetised.
- It can only be used with ferromagnetic material.

-

Different end effectors exist to fit any application in the industry. Manufactures just have to find the best fit for their needs, in order to do the job efficiently with the best ROI.



- Vacuum grippers are used in the robots for grasping the *non – ferrous objects*. It uses *vacuum cups* as the gripping device, which is also commonly known as *suction cups*. This type of grippers will provide good handling if the objects are *smooth, flat, and clean*. It has only one surface for gripping the objects. Most importantly, it is not best suitable for handling the objects with holes.



Suction cups vacuum gripper

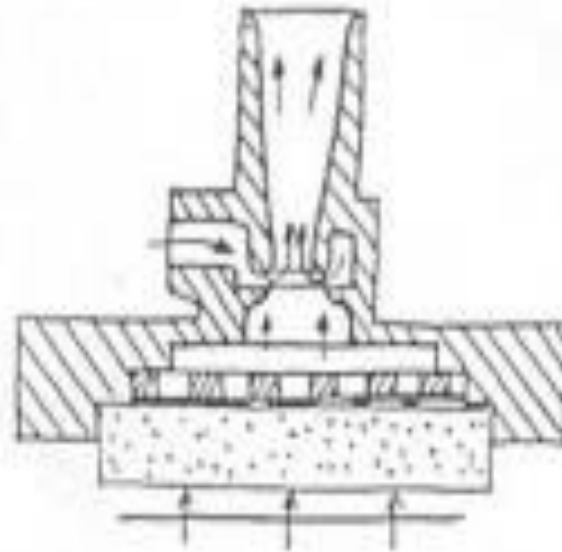

Venturi type vacuum gripper

- **Vacuum cups:**
- Generally, the vacuum cups (suction cups) will be in the round shape. These cups will be developed by means of *rubber* or other elastic materials. Sometimes, it is also made of *soft plastics*. Moreover, the vacuum cups are prepared of hard materials for handling the soft material objects.
- Two different devices are used in the suction cups for creating the vacuum. They are:
- Venturi
- Vacuum pump
- Venturi device is operated with the help of *shop air pressure*, while the vacuum pump is driven either by means of *vane or piston* device. The vacuum pump has the ability to create the *high vacuum*. As the venturi is a simple device, it is more *reliable* and *inexpensive*. Both these devices are very well capable of providing high vacuum if there is a sufficient supply of air pressure.

- **Types of vacuum grippers:**
- The *ball joint* type vacuum gripper is capable of changing into various contact angles automatically. Moreover, the bending moments in the vacuum cups are also decreased. It is used for carrying irregular materials, heavy objects, etc.
- A vacuum gripper with *level compensator* can be very helpful in balancing the objects with different levels. It also has the capability to absorb the shocks.
- **Applications of vacuum grippers:**
- Vacuum grippers are highly useful in the heavy industries, automobiles, compact disc manufacturing, and more for *material handling* purposes.
- It is also used in the tray & box manufacturing, labeling, sealing, bottling, and so on for *packaging* purposes.

Sensors Used in Robot

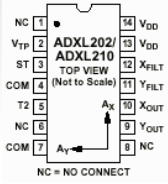

Accelerometer



Gyro



Pendulum Resistive Tilt Sensors



Piezo Bend Sensor



Metal Detector



Gas Sensor



Gieger-Muller Radiation Sensor

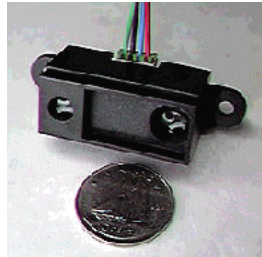

Digital Infrared Ranging



CDS Cell Resistive Light Sensor

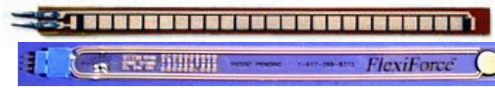

Resistive Bend Sensors



UV Detector



Pyroelectric Detector

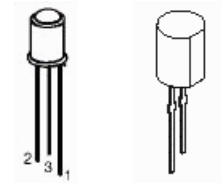

IR Pin Diode



IR Sensor w/lens

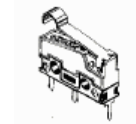

Limit Switch



Mechanical Tilt Sensors



Touch Switch

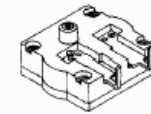

Pressure Switch

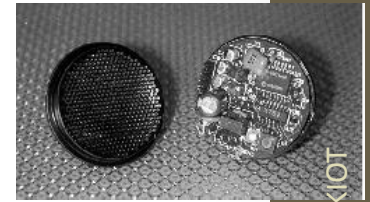

Miniature Polaroid Sensor



IR Reflection Sensor



IR Amplifier Sensor



Thyristor



Magnetic Sensor

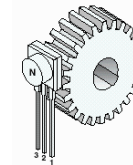

Hall Effect Magnetic Field Sensors

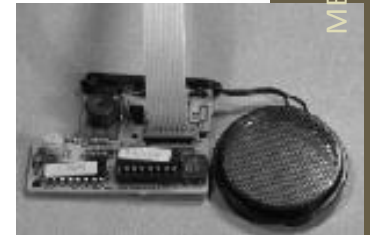

Polaroid Sensor Board

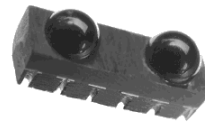

IRDA Transceiver



Magnetic Reed Switch

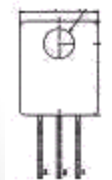

Lite-On IR Remote Receiver

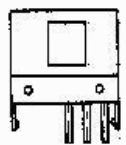

Radio Shack Remote Receiver



IR Modulator Receiver



Solar Cell

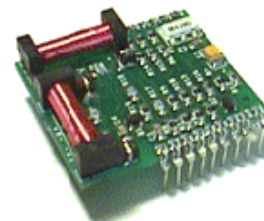

Compass

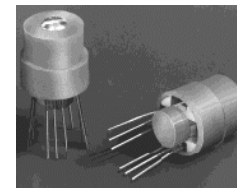

Compass

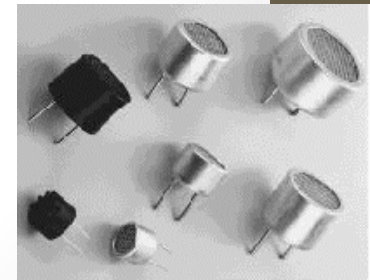

Piezo Ultrasonic Transducers

MECH-KIOT

Sensors used in robot navigation

- Resistive sensors
 - bend sensors, potentiometer, resistive photocells, ...
- Tactile sensors
 - contact switch, bumpers...
- Infrared sensors
 - Reflective, proximity, distance sensors...
- Ultrasonic Distance Sensor
- Inertial Sensors (measure the second derivatives of position)
 - Accelerometer, Gyroscopes,
- Orientation Sensors
 - Compass, Inclinometer
- Laser range sensors
- Vision
- Global Positioning System

Classification of Sensors

- Internal state (proprioception) v.s. external state (exteroceptive)
 - feedback of robot internal parameters, e.g. battery level, wheel position, joint angle, etc,
 - observation of environments, objects
- Active v.s. non-active
 - emitting energy into the environment, e.g., radar, sonar
 - passively receive energy to make observation, e.g., camera
- Contact v.s. non-contact
- Visual v.s. non-visual
 - vision-based sensing, image processing, video camera

Robotic Sensor Classification

- In general, robotic sensors can be divided into two classes:
 - i. **Internal state sensors** - device being used to measure the position, velocity and acceleration of the robot joint and/or end-effector. These devices are potentiometer, tachometers, synchros, resolvers, differential transformers, optical interrupters, optical encoders and accelerometer.
 - ii. **External state sensors** – device being used to monitor the relationship between the robot kinematics and/or dynamics with its task, surrounding, or the object being manipulated.

Sensor Selection/Sensing Taxonomy

- There are many different types of robot sensors available and there are many different parameter measured by these sensors.
- The application process, should be carried out in a top down manner, starting with task requirements, and going through several levels of analysis, eventually leading to the selection of a specific device.
- A taxonomy for sensing to aid this process consists of five levels of refinement leading to sensor selection:
 1. **Specification of task requirements** :eg localization, slippage detection, size confirmation, inspection, defect testing.
 2. **Choice of modality** :eg,vision, force, tactile
 3. **Specification on sensor attributes** :eg,output, complexity, discrete or continuous variable, imaging or non-imaging, local or global
 4. **Specification of operational parameters** :eg size, accuracy, cost
 5. **Selection of mechanism** :eg switching devices, inductive sensors, CCD vision imaging

Some typical sensor operational data:

- Ultrasonics
- Resistive Effects
- Capacitive Effects
- Piezo-Electric Effects
- Visible Light Imaging
- Photo-Electric & Infrared
- Mechanical Switching
- Inductive Effects
- Thermal Effects
- Hall Effect

Primary physical mechanisms employed in sensors:

Cost
Range
Accuracy
Repeatability
Power Requirements
Output Signal Specification
Processing Requirements
Sensitivity
Reliability
Weight
Seize

SENSORS FOR INDUSTRIAL ROBOTS

Proximity and Range Sensors

Tactile Sensors

Vision Sensors

Miscellaneous Sensors

PROXIMITY & RANGE SENSORS

I

- It is a technique of detecting the presence or absence of an object with electronic noncontact sensors.
- Typical application of proximity sensors includes:
 - ψ Object detection
 - ψ Collision avoidance
 - ψ Object verification & counting
- Commonly available proximity sensors are:
 1. Photoelectric/optical sensors
 2. Inductive proximity sensors
 3. Capacitive proximity sensors
 4. Ultrasonic proximity sensors

Resistive Sensors

Bend Sensors

- Resistance = 10k to 35k
- As the strip is bent, resistance increases

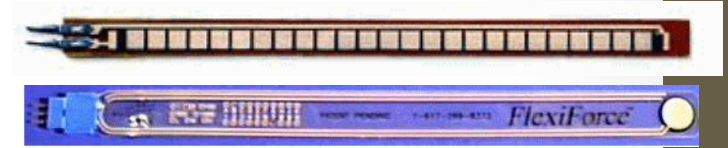

Resistive Bend Sensor

Potentiometers

- Can be used as position sensors for sliding mechanisms or rotating shafts
- Easy to find, easy to mount



Potentiometer

Light Sensor (Photocell)

- Good for detecting direction/presence of light
- Non-linear resistance
- Slow response to light changes



Photocell

R is small when brightly illuminated

Applications

- Measure bend of a joint
- Wall Following/ Collision Detection
- Weight Sensor

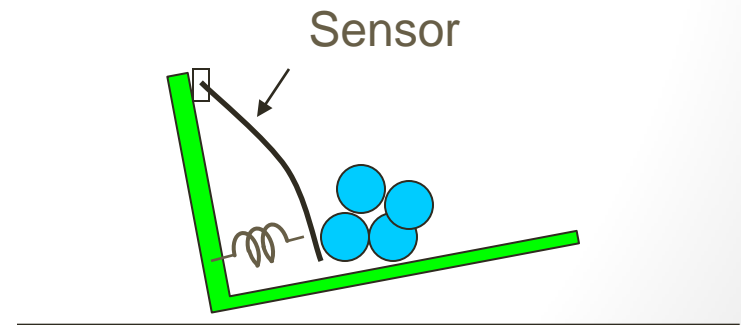
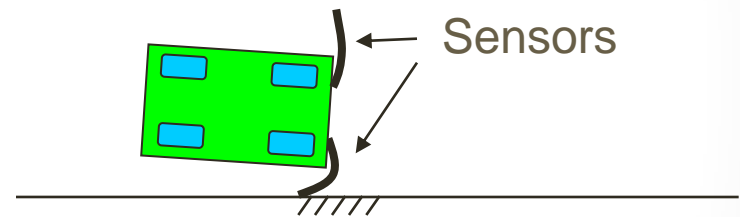
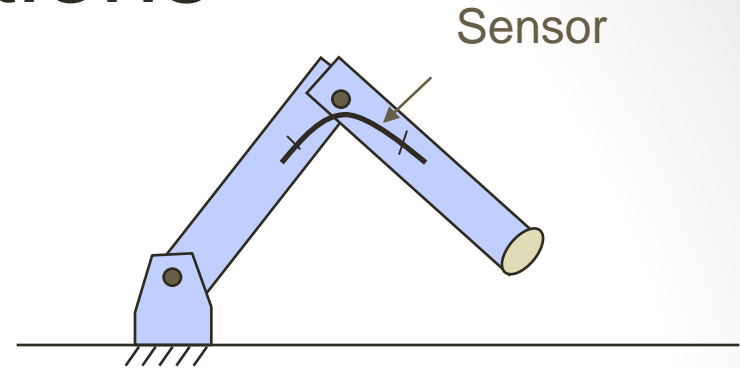

Infrared Sensors

- Intensity based infrared
 - Reflective sensors
 - Easy to implement
 - susceptible to ambient light
- Modulated Infrared
 - Proximity sensors
 - Requires modulated IR signal
 - Insensitive to ambient light
- Infrared Ranging
 - Distance sensors
 - Short range distance measurement
 - Impervious to ambient light, color and reflectivity of object

Intensity Based Infrared

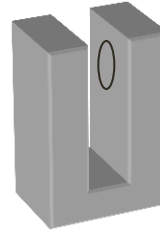
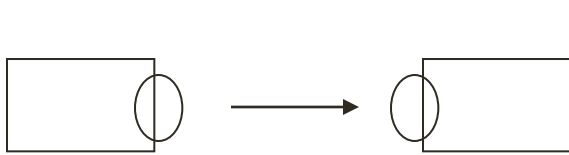

Break-Beam sensor

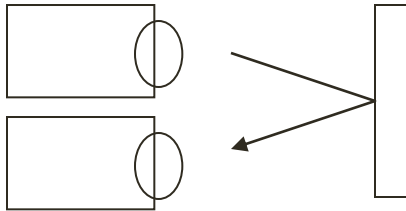

Reflective Sensor

- Easy to implement (few components)
- Works very well in controlled environments
- Sensitive to ambient light

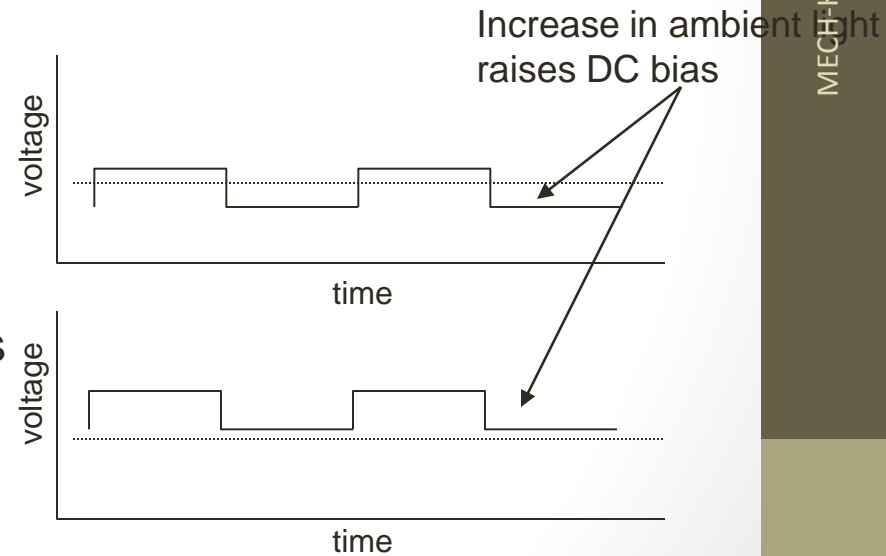

IR Reflective Sensors

- Reflective Sensor:
 - Emitter IR LED + detector photodiode/phototransistor
 - Phototransistor: the more light reaching the phototransistor, the more current passes through it
 - A beam of light is reflected off a surface and into a detector
 - Light usually in infrared spectrum, IR light is 'invisible'

- Applications:
 - Object detection,
 - Line following, Wall tracking
 - Optical encoder (Break-Beam sensor)

- Drawbacks:
 - Susceptible to ambient lighting
 - Provide sheath to insulate the device from outside lighting
 - Susceptible to reflectivity of objects
 - Susceptible to the distance between sensor and the object

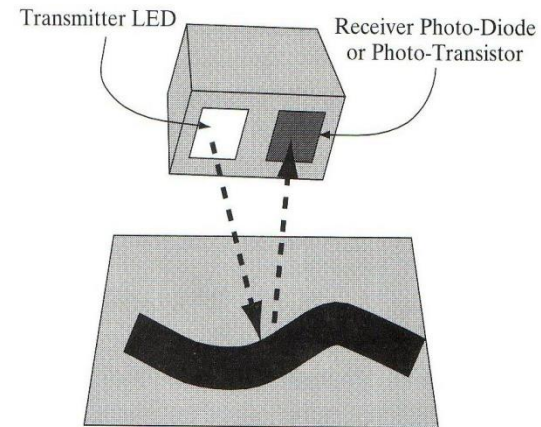

Modulated Infrared

- Modulation and Demodulation
 - Flashing a light source at a particular frequency
 - Demodulator is tuned to the specific frequency of light flashes. (32kHz~45kHz)
 - Flashes of light can be detected even if they are very weak
 - Less susceptible to ambient lighting and reflectivity of objects
 - Used in most IR remote control units, proximity sensors

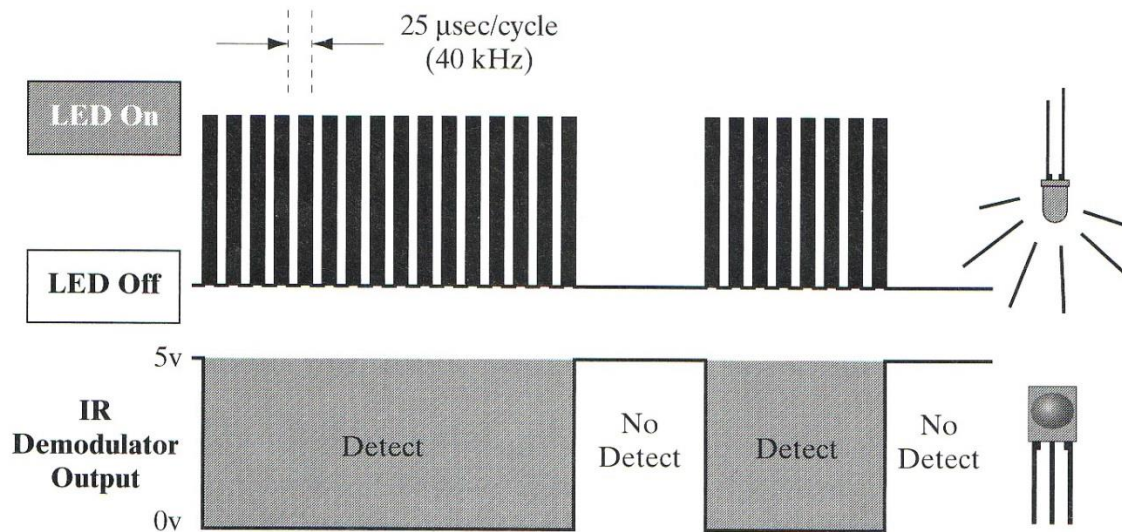

Negative true
logic:

Detect = 0v

No detect = 5v

IR Proximity Sensors

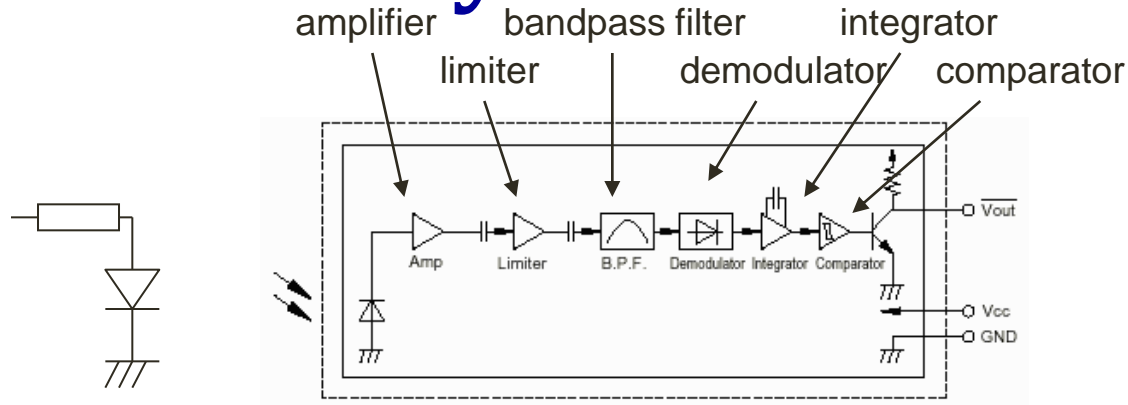

- Proximity Sensors:
 - Requires a modulated IR LED, a detector module with built-in modulation decoder
 - Current through the IR LED should be limited: adding a series resistor in LED driver circuit
 - Detection range: varies with different objects (shiny white card vs. dull black object)
 - Insensitive to ambient light
- Applications:
 - Rough distance measurement
 - Obstacle avoidance
 - Wall following, line following

IR Distance Sensors

- Basic principle of operation:
 - IR emitter + focusing lens + position-sensitive detector

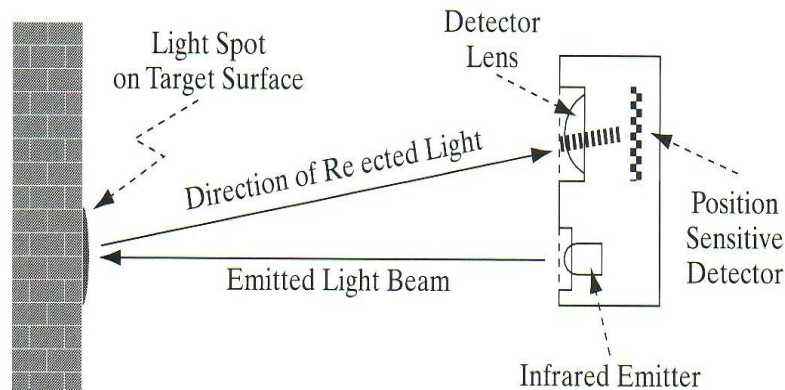

Modulated IR light



Location of the spot on the detector corresponds to the distance to the target surface, Optics to convert horizontal distance to vertical distance

Fig. 1 Distance Measuring Output vs. Distance to Reflective Object

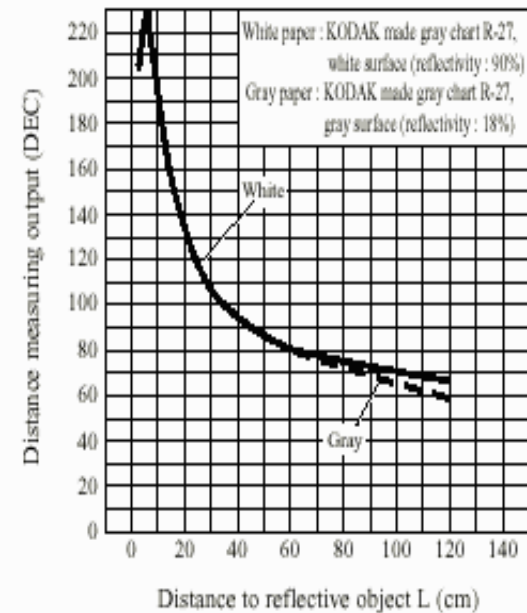

IR Distance Sensors

- Sharp GP2D02 IR Ranger
 - Distance range: 10cm (4") ~ 80cm (30").
 - Moderately reliable for distance measurement
 - Immune to ambient light
 - Impervious to color and reflectivity of object
 - Applications: distance measurement, wall following, ...

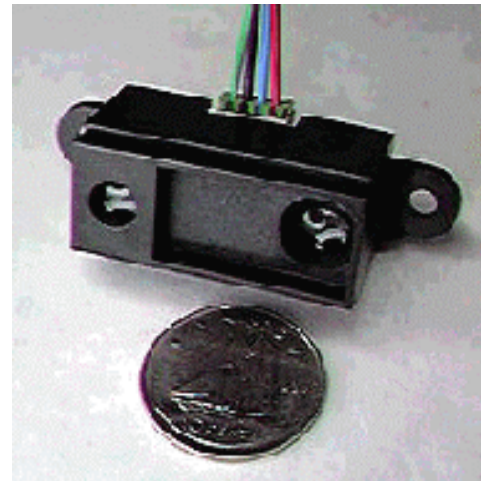

Range Finder

(Ultrasonic, Laser)

Range Finder



- Time of Flight
- The measured pulses typically come from ultrasonic, RF and optical energy sources.
 - $D = v * t$
 - D = round-trip distance
 - v = speed of wave propagation
 - t = elapsed time
- Sound = 0.3 meters/msec
- RF/light = 0.3 meters / ns (Very difficult to measure short distances 1-100 meters)

Ultrasonic Sensors

- Basic principle of operation:
 - Emit a quick burst of ultrasound (50kHz), (human hearing: 20Hz to 20kHz)
 - Measure the elapsed time until the receiver indicates that an echo is detected.
 - Determine how far away the nearest object is from the sensor

$$D = v * t$$

D = round-trip distance

v = speed of propagation(340 m/s)

t = elapsed time

Bat, dolphin, ...

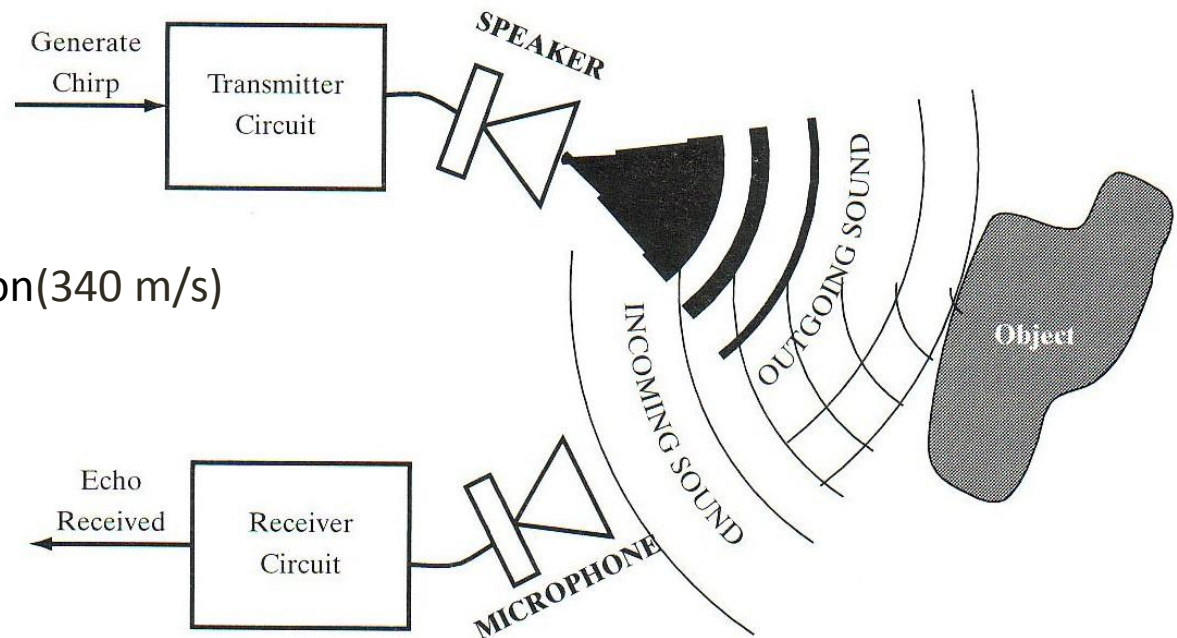

Ultrasonic Sensors

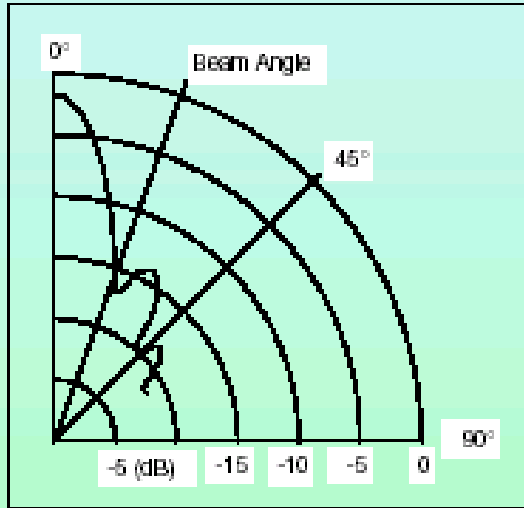

Sensor Specification

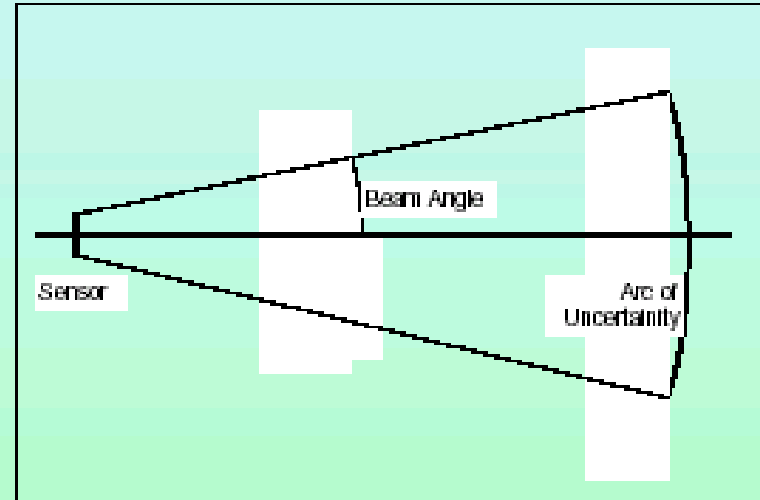

Sensor Model, angle = 15 degrees

- Ranging is accurate but bearing has a 30 degree uncertainty. The object can be located anywhere in the arc.
- Typical ranges are of the order of several centimeters to 30 meters.
- Another problem is the propagation time. The ultrasonic signal will take 200 msec to travel 60 meters. (30 meters roundtrip @ 340 m/s)

Ultrasonic Sensors

- Polaroid ultrasonic ranging system
 - It was developed for auto-focus of cameras.
 - Range: 6 inches to 35 feet

Transducer Ringing:

- transmitter + receiver @ 50 KHz
- Residual vibrations or ringing may be interpreted as the echo signal
- Blanking signal to block any return signals for the first 2.38ms after transmission

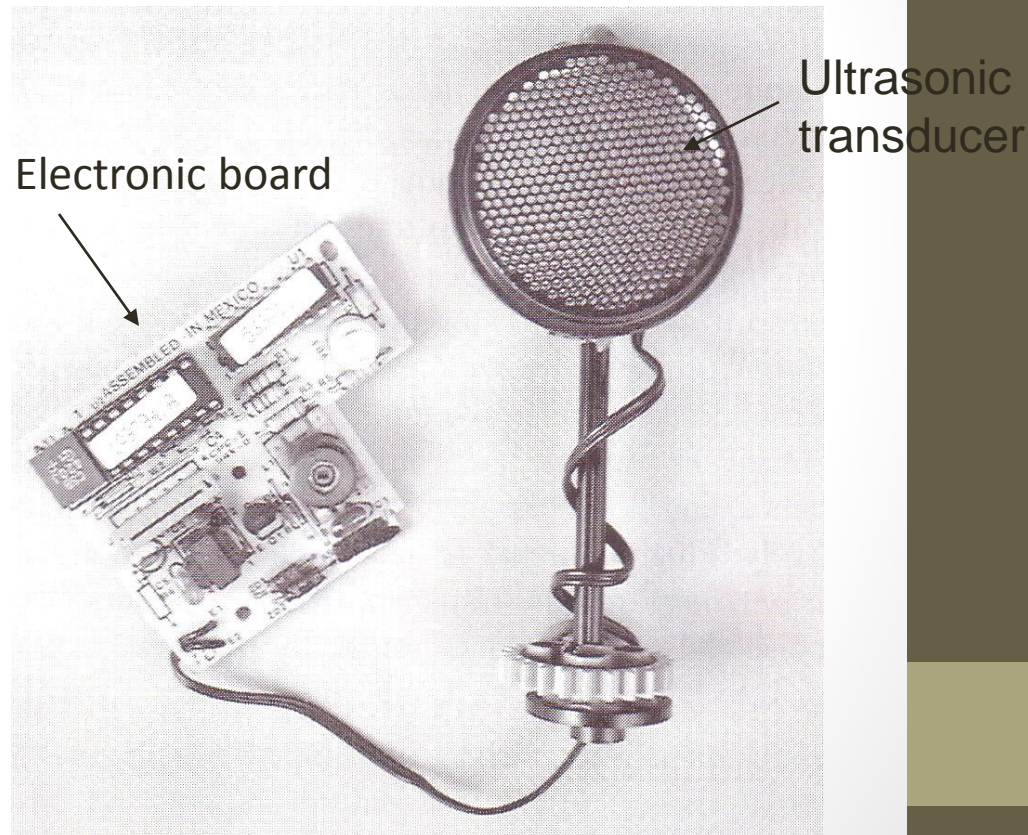

Operation with Polaroid Ultrasonic

- The Electronic board supplied has the following I/O
 - **INIT** : trigger the sensor, (16 pulses are transmitted)
 - **BLANKING** : goes high to avoid detection of own signal
 - **ECHO** : echo was detected.
 - **BINH** : goes high to end the blanking (reduce blanking time 2.38 ms)
 - **BLNK** : to be generated if multiple echo is required

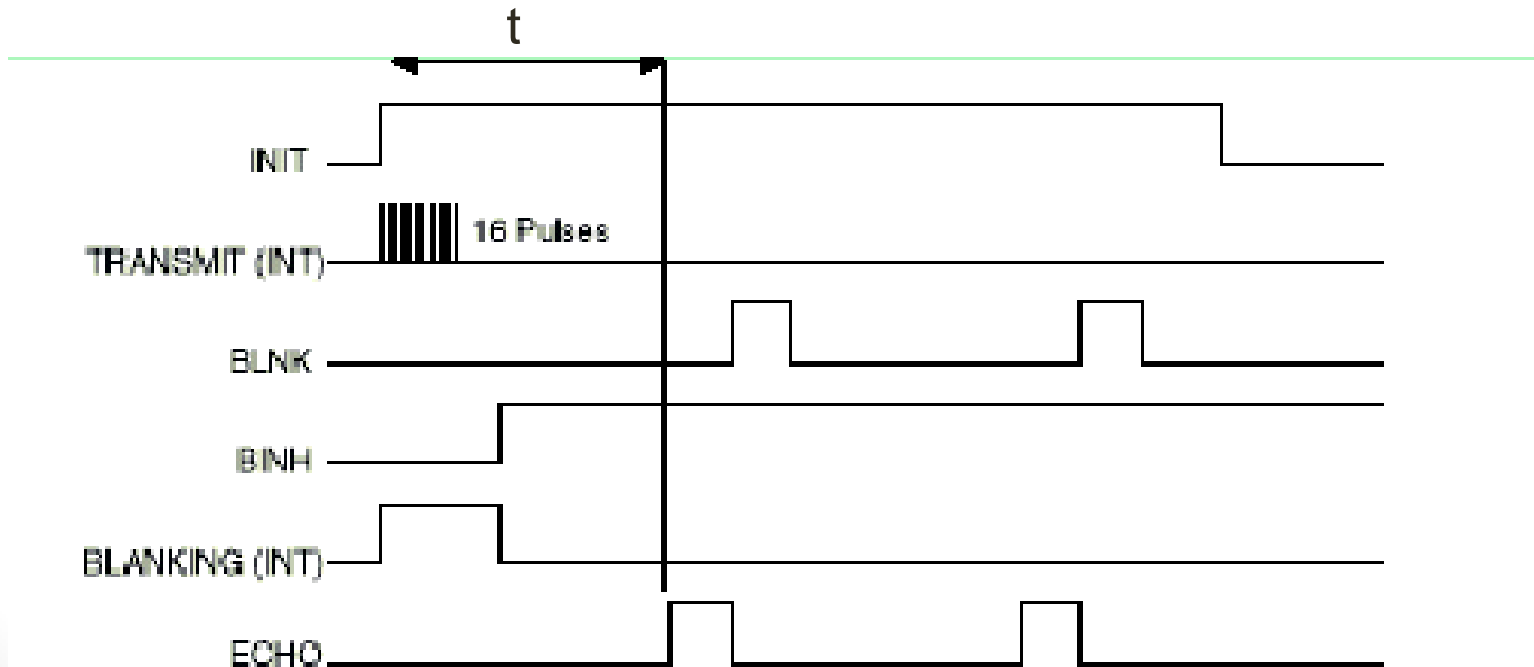

Ultrasonic Sensors

- Applications:
 - Distance Measurement
 - Mapping: Rotating proximity scans (maps the proximity of objects surrounding the robot)

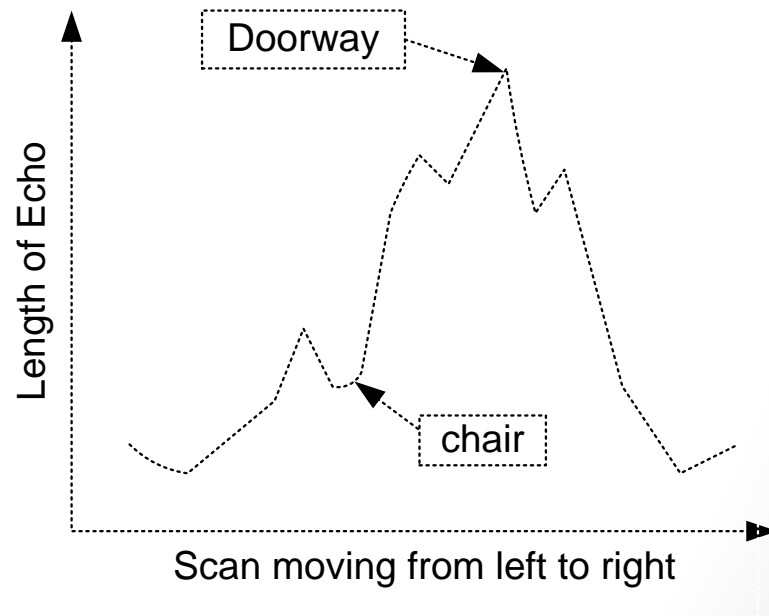
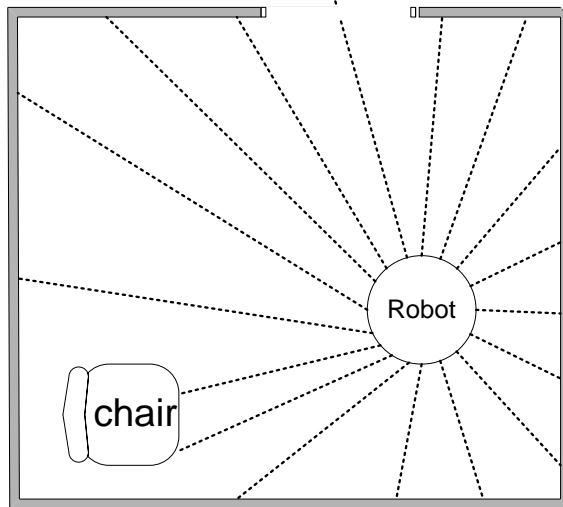

Scanning at an angle of 15° apart can achieve best results

Noise Issues

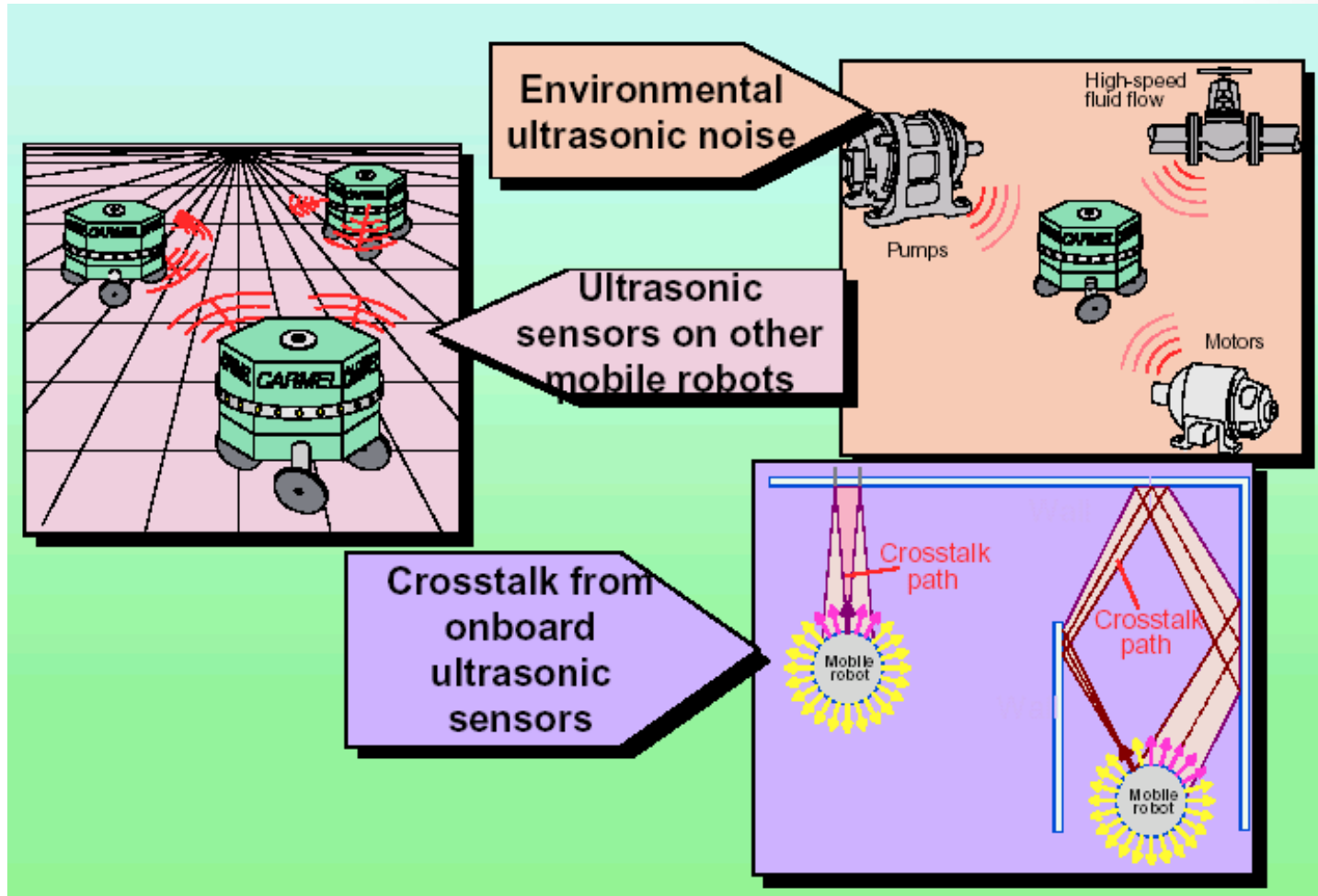

Laser Ranger Finder

- Range 2-500 meters
- Resolution : 10 mm
- Field of view : 100 - 180 degrees
- Angular resolution : 0.25 degrees
- Scan time : 13 - 40 msec.
- These lasers are more immune to Dust and Fog



<http://www.sick.de/de/products/categories/safety/>

TACTILE SENSORS

- Tactile sensing includes any form of sensing which requires physical touching between the sensor and the object to be sense.
- The need for touch or tactile sensors occurs in many robotic applications, from picking oranges to loading machines. Probably the most important application currently is the general problem of locating, identifying, and organizing parts that need to be assembled.
- **Tactile sensor system includes the capability to detect such things as:**
 1. Presence
 2. Part shape, location, orientation, contour examination
 3. Contact are pressure and pressure distribution
 4. Force magnitude, location, and direction
 5. Surface inspection : texture monitoring, joint checking, damage detection
 6. Object classification : recognition, discrimination
 7. Grasping : verification, error compensation (slip, position ,orientation)
 8. Assembly monitoring

- **The major components of a tactile/touch sensor system are:**
 - 1. A touch surface**
 - 2. A transduction medium, which convert local forces or moments into electrical signals.**
 - 3. Structure**
 - 4. Control/interface**

Method of Transduction

Resistive

- It is the transduction method in tactile sensor design which has received the most attention. It is concerned with the change in resistance of a conductive material under applied pressure.
- This technique involves measuring the resistance either through or across the thickness of a conductive elastomer. Most elastomers are made from carbon- or silicon-doped rubber.

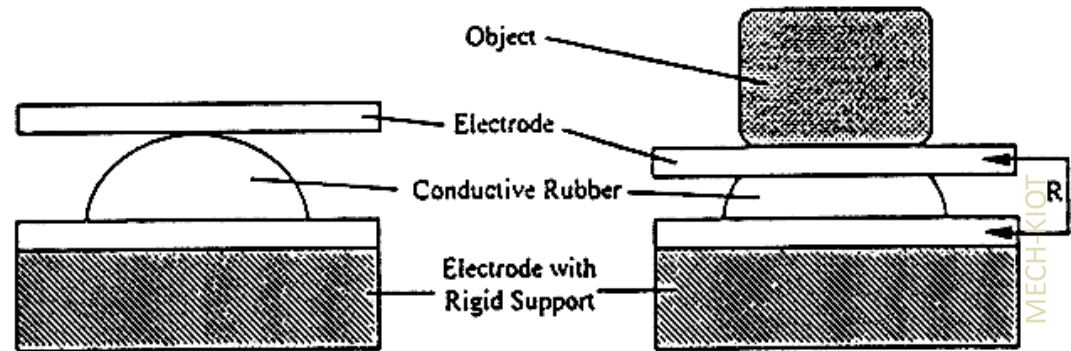

Resistive Tactile Element –
Resistance Measured Through
The rubber

- **Advantages:**
 1. Wide dynamic range
 2. Durability
 3. Good overload tolerance
 4. Compatibility with integrated circuitry, particularly VLSI.
- **Disadvantages:**
 1. Hysteresis in some designs.
 2. Elastomer needs to be optimized for both mechanical and electrical properties.
 3. Limited spatial resolution compared with vision sensors.
 4. Larger numbers of wires may have to be brought away from the sensor.
 5. Monotonic response but often not linear.

Resistive Tactile Element –
Resistance Measured Across the rubber

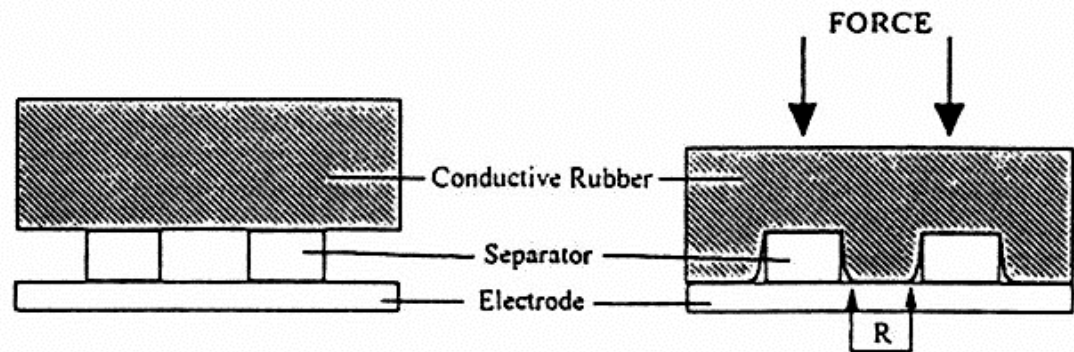

Method of Transduction

Piezoelectric & Pyroelectric Effects

- Piezoelectric effect is the generation of a voltage across a sensing element when pressure applied to it. The voltage generated is proportionally related to the applied pressure. No external voltage is required, and a continuous analogue output is available from such sensor.
- A pyroelectric effect is the generation of a voltage when the sensing element is heated or cooled.
- Polymeric materials with piezoelectric and pyroelectric properties are appropriate for use with sensors.

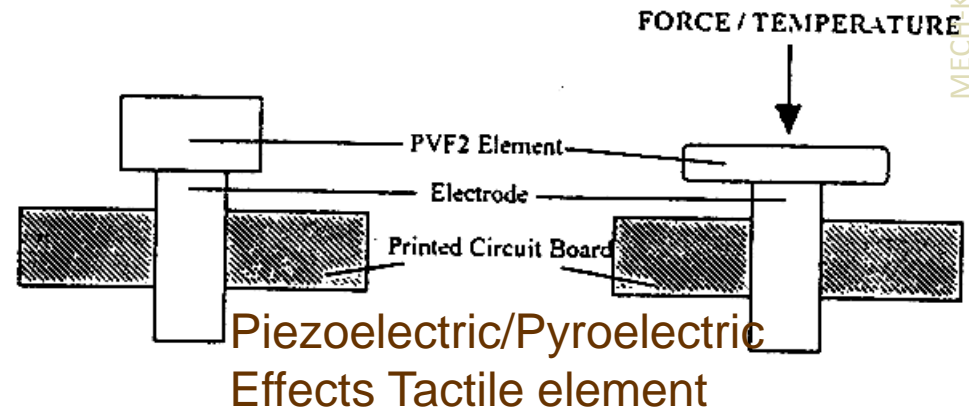

- **Advantages:**

1. Wide dynamic range
2. Durability
3. Good mechanical properties of piezoelectric from pyroelectric materials
4. Temperature as well as force sensing capabilities

- **Disadvantages:**

1. Difficult of separating piezoelectric from pyroelectric effects
2. Inherently dynamic - output decay to zero for constant load
3. Difficult of scanning elements
4. Good solution are complex

Method of Transduction

CAPACITIVE TECHNIQUE

- Tactile sensors within this category are concerned with measuring capacitance, which made to vary under applied load.
- The capacitance of a parallel plate capacitor depends upon the separation of the plates and their area, so that a sensor using an elastomeric separator between the plates provides compliance such that the capacitance will vary according to applied load.

MEMS

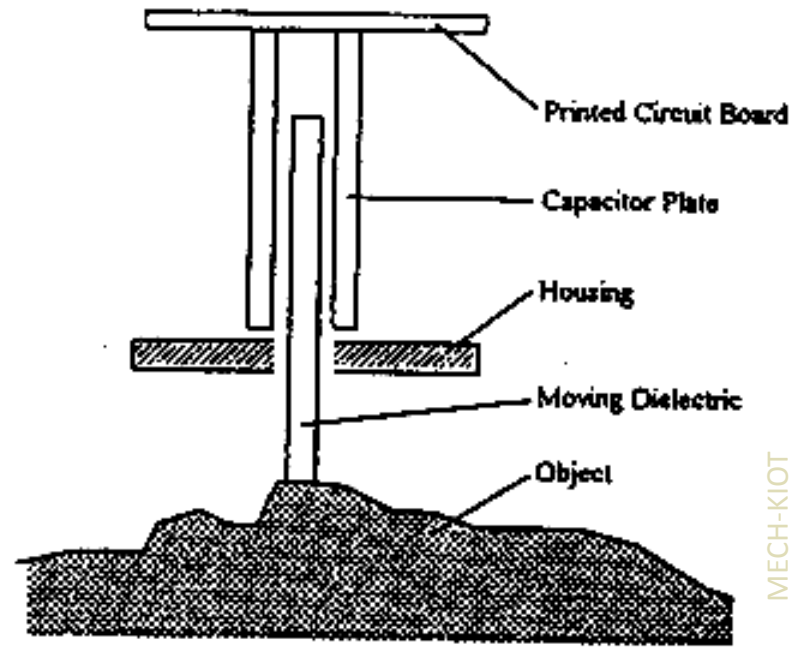
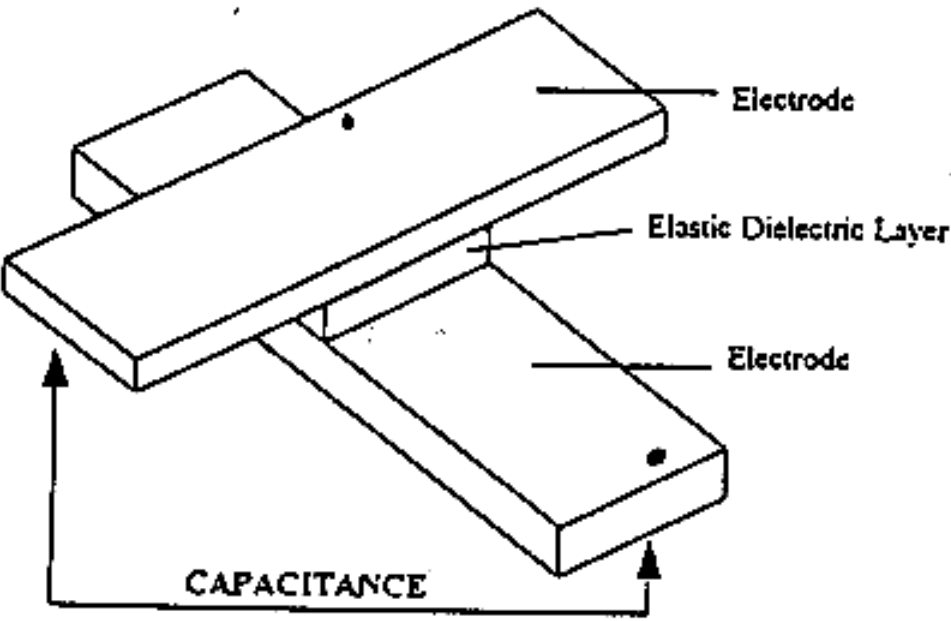

MECH-KIOT

Capacitive Tactile Element

- **Advantages:**
 1. Wide dynamic range
 2. Linear response
 3. Robust
- **Disadvantages:**
 1. Susceptible to noise
 2. Some dielectrics are temperature sensitive
 3. Capacitance decreases with physical size ultimately limiting spatial resolution.

Method of Transduction

Transduction

- **A Linear Potentiometer**
- **Advantages:**
 1. Well known Technology
 2. Good for probe application
- **Disadvantages:**
 1. Limited spatial resolution
 2. Complex for array construct

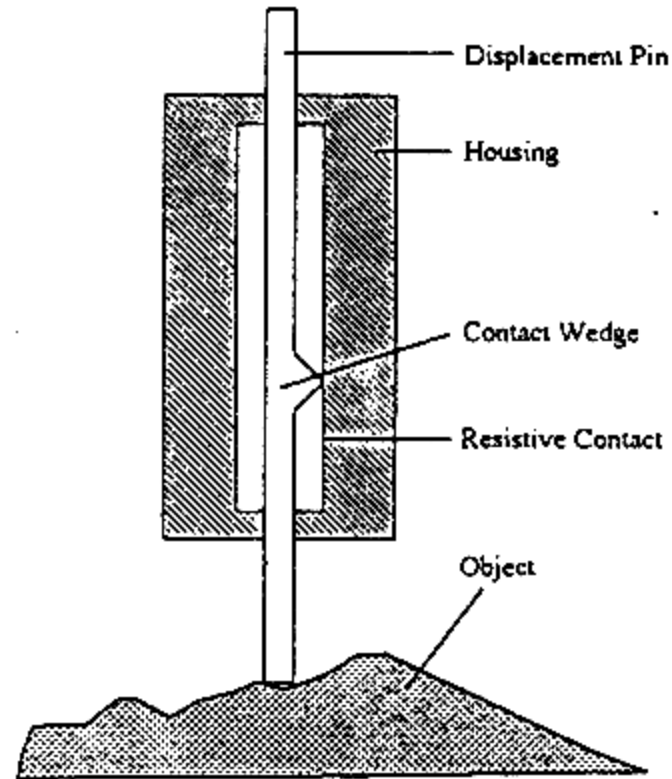

Mechanical Transducer
A linear Potentiometer

Magnetic Transduction Methods

- Sensors using magnetic transduction are divided into **two** basic categories:

Groups together sensors which use mechanical movement to produce change in magnetic flux.

- **Advantages:**

1. Wide dynamic range
2. Large displacements possible
3. Simple

- **Disadvantages:**

1. Poor spatial resolution
2. Mechanical problems when sensing on slopes.

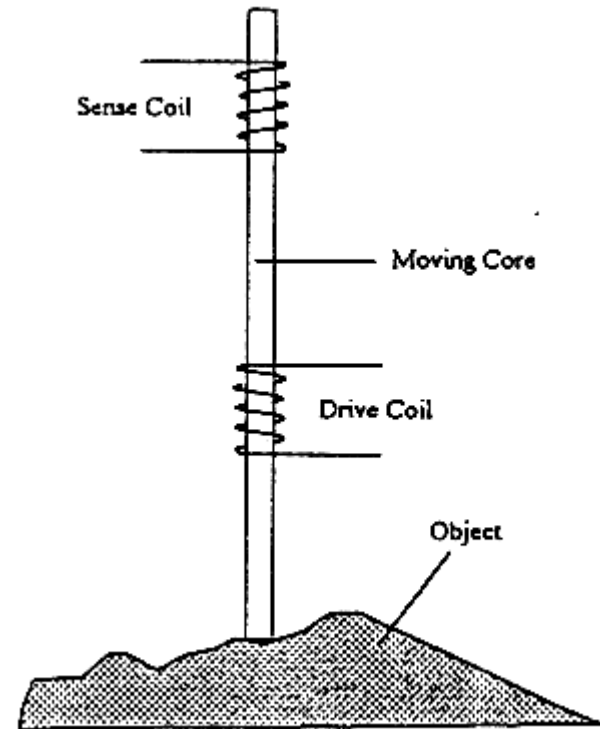

Magnetic tactile Element

2. Concerns magnetoelastic materials which show a change in magnetic field when subjected to mechanical stress.

- **Advantages:**

1. Wide dynamic range
2. Linear response
3. Low hysteresis
4. Robust

- **Disadvantages:**

1. Susceptible to stray field and noise.
2. A.C. circuit required

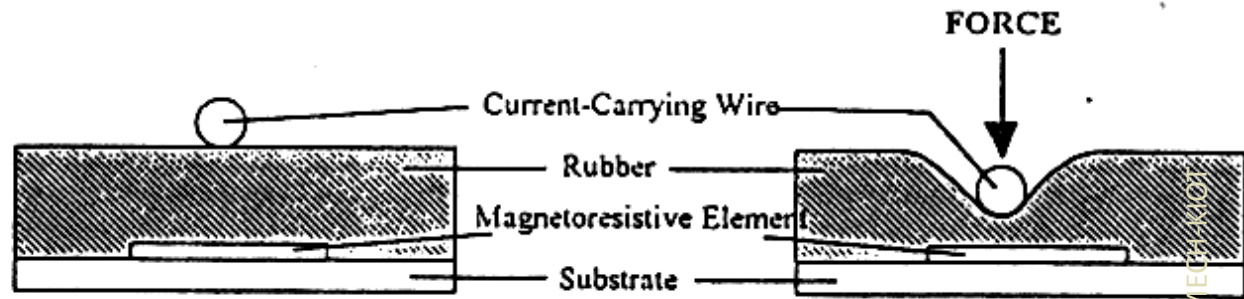

Magneto resistive tactile Element

Method of Transduction

Optical Transduction Methods

- **Advantages:**

1. Very high resolution
2. Compatible with vision sensing technology
3. No electrical interference problems
4. Processing electronics can be remote from sensor
5. Low cabling requirements

- **Disadvantages:**

1. Dependence on elastomer in some designs – affects robustness
2. Some hysteresis

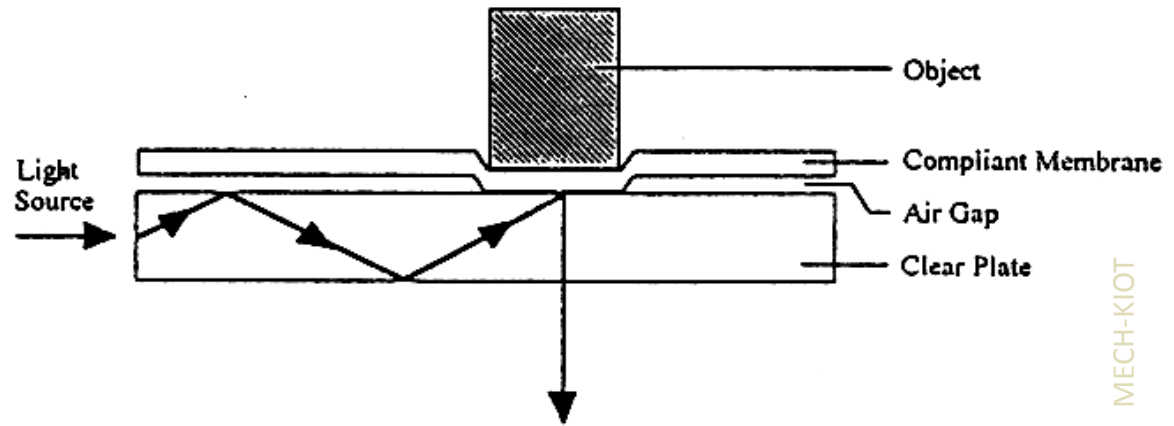

Optical Tactile Element
Pressure to light Transduction

ROBOT VISION

- Vision is the most powerful robot sensory capabilities. Enables a robot to have a sophisticated sensing mechanism that allows it to respond to its environment in intelligent and flexible manner. Therefore machine vision is the most complex sensor type.
- Robot vision may be defined as the process of extracting, characterizing, and interpreting information from images of a three-dimensional world. This process, also known as machine or computer vision may be subdivided into six principle areas. These are:
 1. **Sensing** : the process that yields visual image
 2. **Preprocessing** : deals with techniques such as noise reduction and enhancement of details
 3. **Segmentation** : the process that partitions an image into objects of interest
 4. **Description**: deals with that computation of features for example size or shape, suitable for differentiating one type of objects from another.
 5. **Recognition**: the process that identifies these objects (for example wrench, bolt, engine block, etc.)
 6. **Interpretation**: assigns meaning to an ensemble of recognized objects.

IMAGING COMPONENTS

- The imaging component, the “eye” or sensor, is the first link in the vision chain. Numerous sensors may be used to observe the world. There are four type of vision sensors or imaging components:

- **1. Point sensors**

capable of measuring light only at a single point in space. These sensor using coupled with a light source (such as LED) and used as a noncontact ‘feeler’

It also may be used to create a higher – dimensions set of vision Information by scanning across a field of view by using mechanisms such as orthogonal set of scanning mirrors

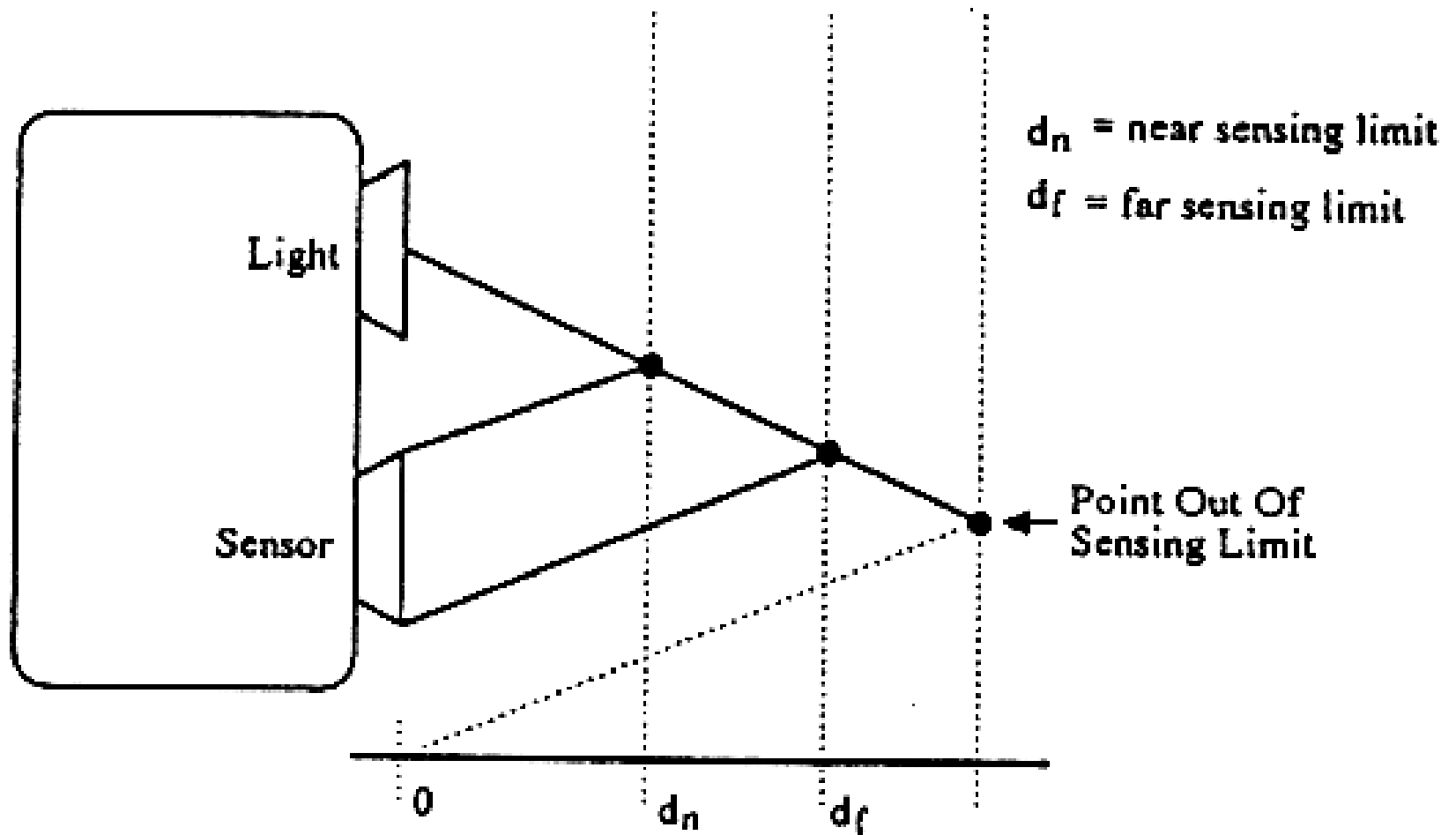

Noncontact feeler-point sensor

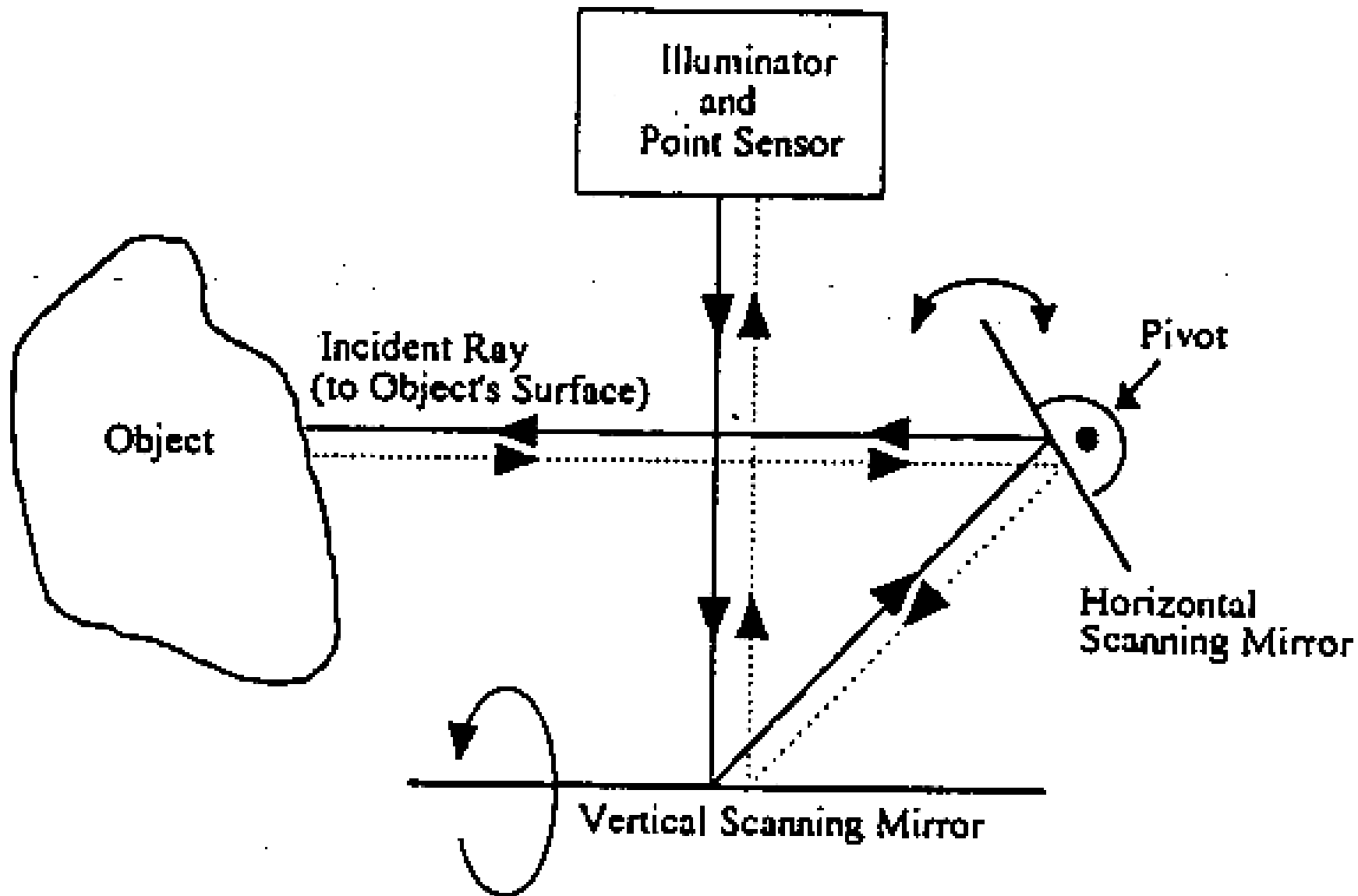
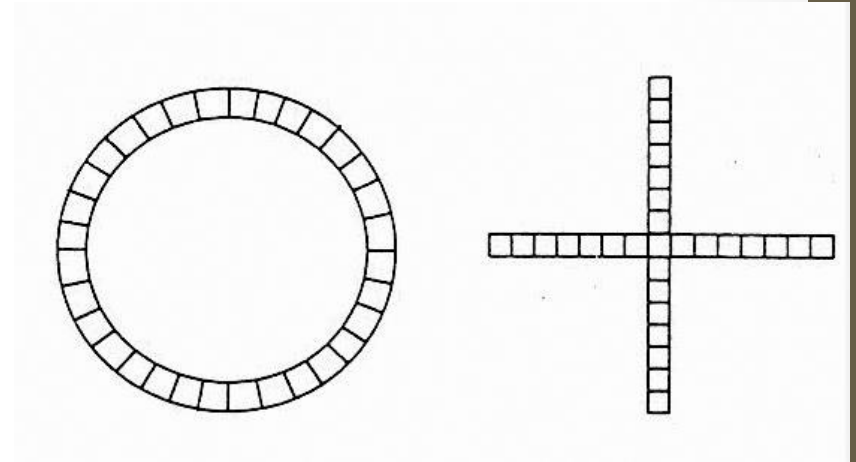

Image scanning using a point sensor and oscillating deflecting mirrors

2. Line Sensor

- Line sensors are one-dimensional devices used to collect vision information from a real scene in the real world.
- The sensor most frequently used is a “line array” of photodiodes or charger-couple-device components.
- It operates in a similar manner to analog shift register, producing sequential, synchronized output of electrical signals, corresponding to the light intensity falling on an integrated light-collecting cell.



Circular and cross configurations of light sensors

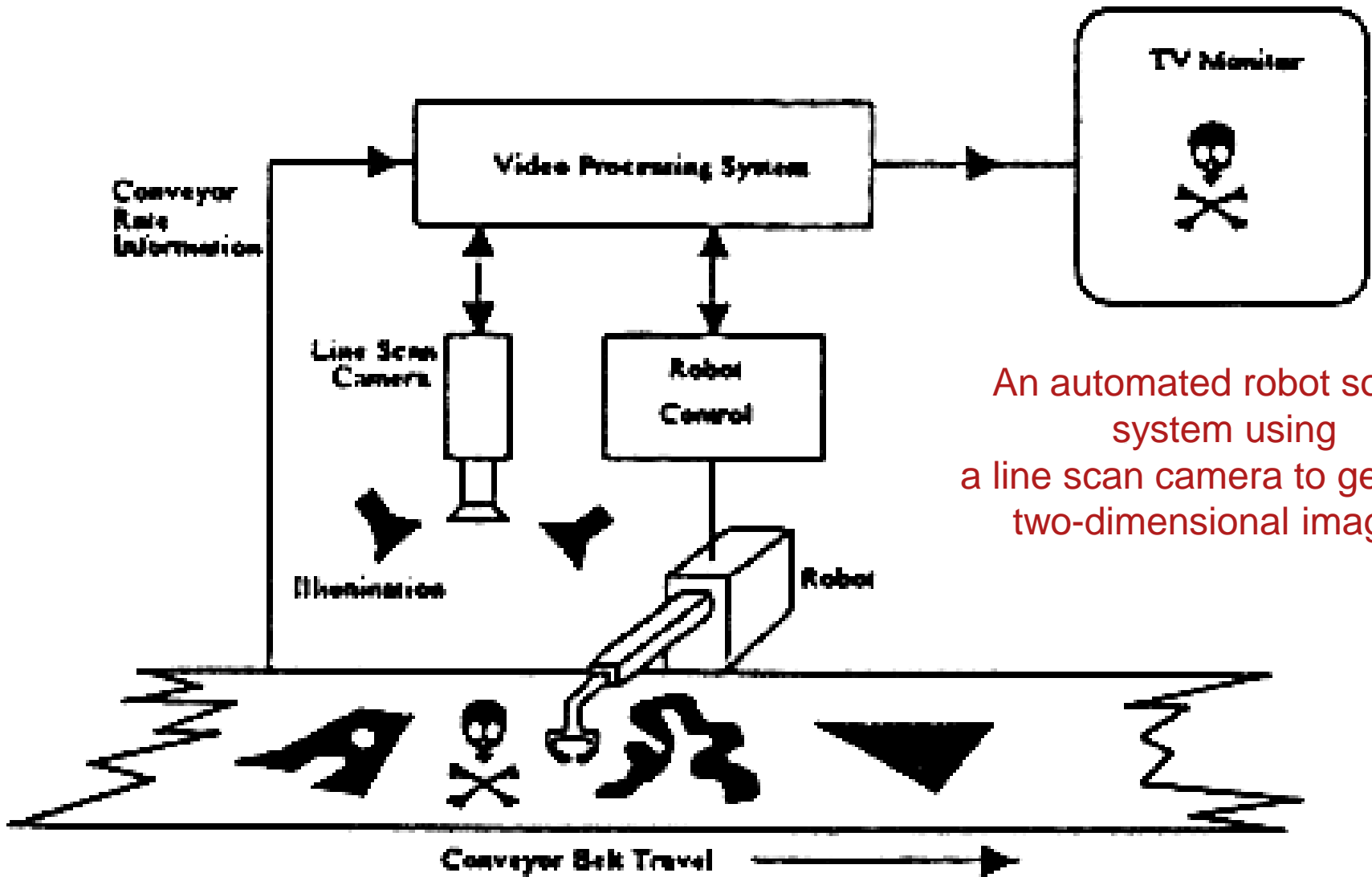

An automated robot sorting system using a line scan camera to generate two-dimensional images.

MECH-KIOT

- Line array may be used to image scene. E.g. by fixing the position of a straight-line sensor and moving an object orthogonally to the orientation of the array, one may scan the entire object of interest.

3. Planar Sensor

- A two dimensional configuration of the line-scan concept. Two generic types of these sensors generally in use today are scanning photomultipliers and solid-state sensors.
- Photomultipliers are represented by television cameras, the most common of which is the vidicon tube, which essentially an optical-to-electrical signal converter.
- In addition to vidicon tubes, several types of solid-state cameras are available. Many applications require the solid-state sensors because of weight and noise factor (solid-state arrays are less noisy but more expensive). This is important when mounting a camera near or on the end-effector of a robot.

4. Volume Sensor

- A sensor that provide three-dimensional information. The sensor may obtain the information by using the directional laser or acoustic range finders.

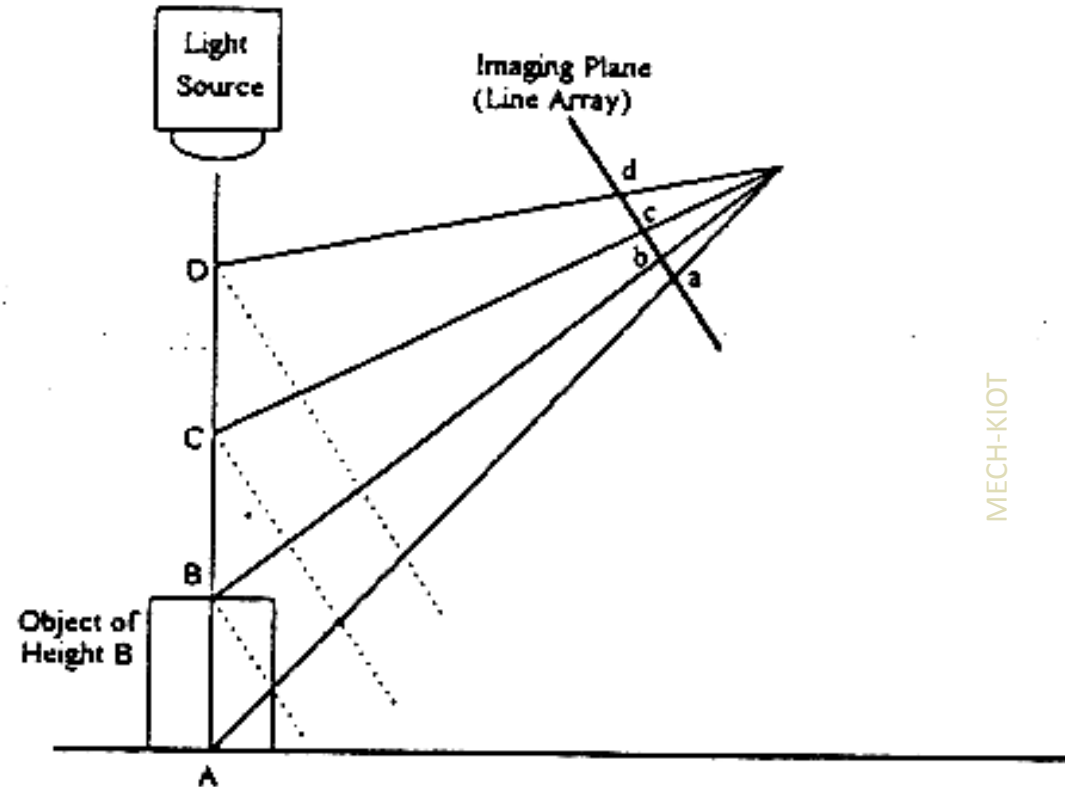

Schematic representation
of a triangulation range finder

IMAGE REPRESENTATION

- From the diagram below. $F(x,y)$ is used to denote the two-dimensional image out of a television camera or other imaging device.
- “x” and “y” denote the **spatial coordinates** (image plane)
- “f” at any point (x,y) is proportional to the **brightness (intensity)** of the image at that point.
- In form suitable for computer processing, an image function $f(x,y)$ must be digitized both spatially and in amplitude (intensity). Digitization of the spatial coordinates (x,y) will be known as image sampling, while amplitude digitization is known as intensity or grey-level quantization.
- The array of (N, M) rows and columns, where each sample is sampled uniformly, and also quantized in intensity is known as a digital image. Each element in the array is called image element, picture element (or pixel).

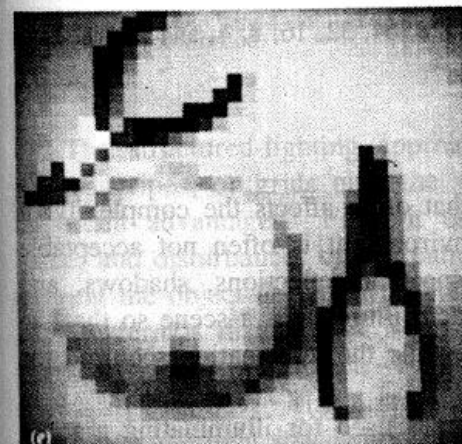
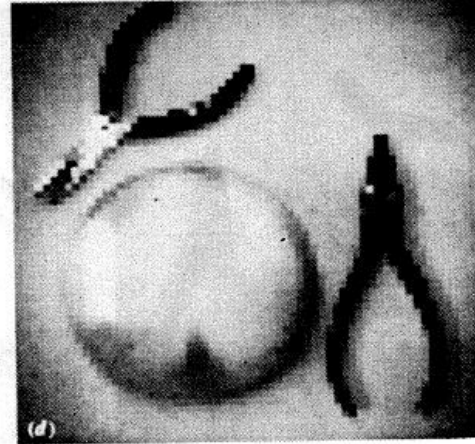
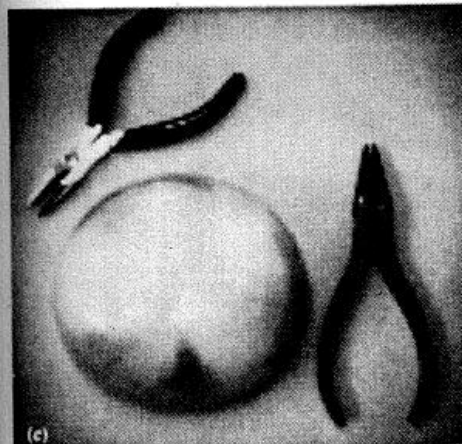
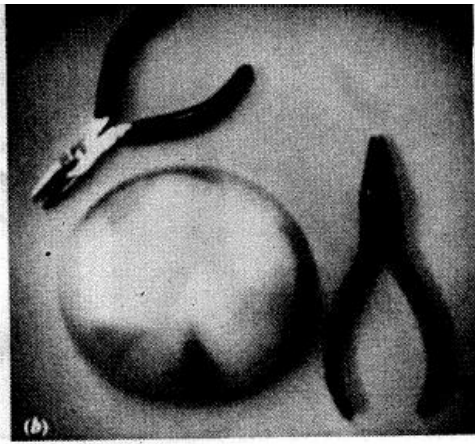
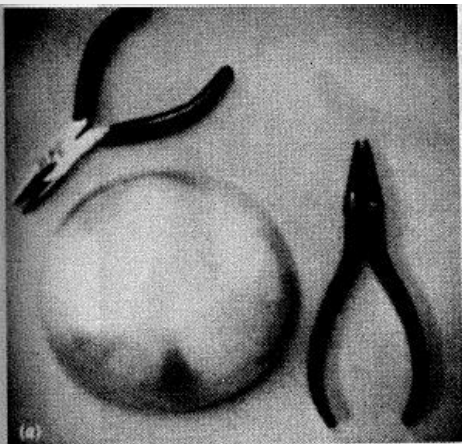

Effects of reducing sampling grid size.

- a) 512x512.
- b) 256x256.
- c) 128x128.
- d) 64x64.
- e) 32x32.

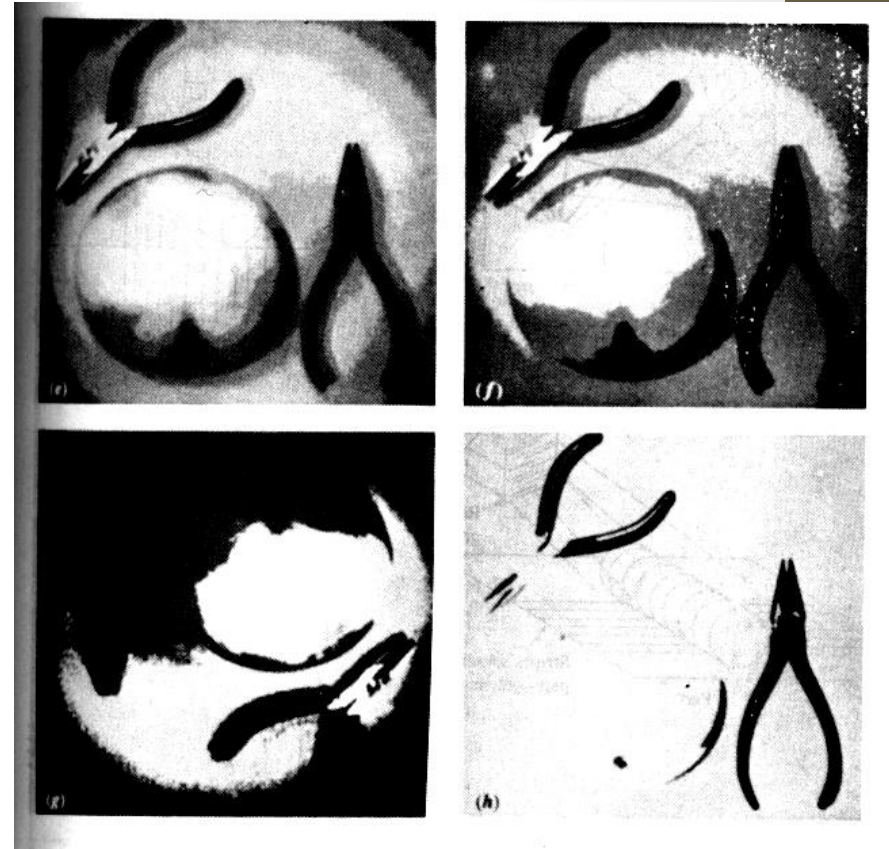
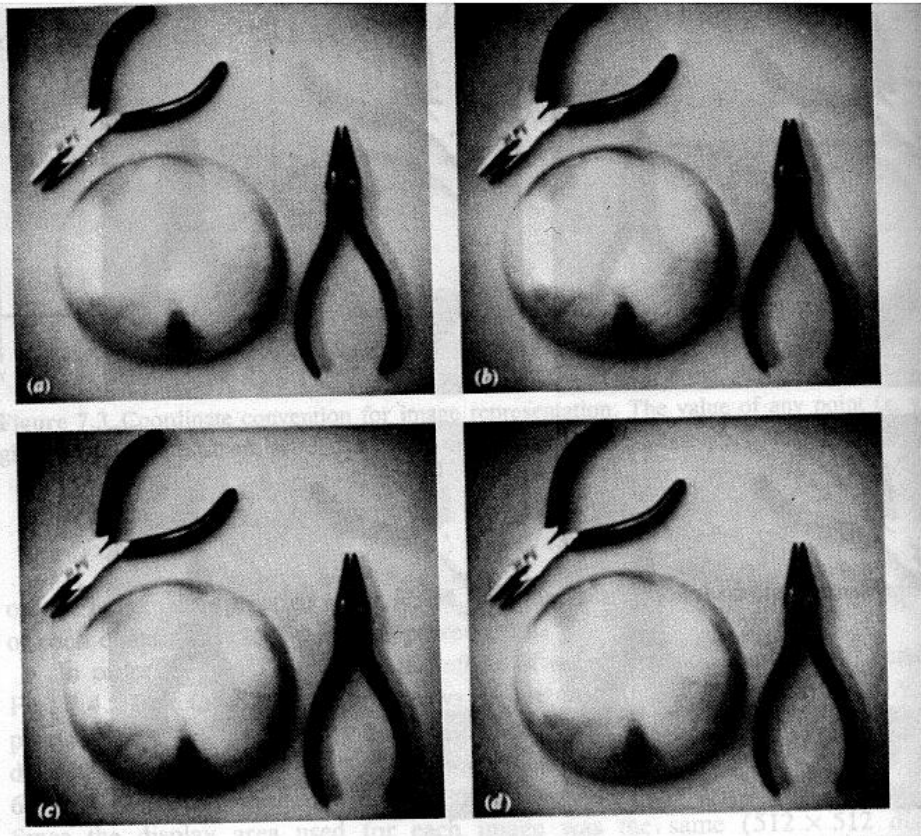

Effect produced by reducing the number of intensity levels while maintaining the spatial resolution constant at 512x512. The 256-, 128- and 64-levels are of acceptable quality.

a) 256, b) 128, c) 64, d) 32, e) 16, f) 8, g) 4, and h) 2 levels

ILLUMINATION TECHNIQUES

- Illumination of a scene is an important factor that often affects the complexity of vision algorithms.
- A well designed lighting system illuminates a scene so that the complexity of the resulting image is minimised, while the information required for object detection and extraction is enhanced.
- Arbitrary lighting of the environment is often not acceptable because it can result in low contrast images, specular reflections, shadows and extraneous details.
- There are **4 main illumination techniques** for a robot work space :

ILLUMINATION TECHNIQUES

1. DIFFUSE-LIGHTING

- This technique is for smooth, regular surface object. It is used where surface characteristic are important.
- Example:

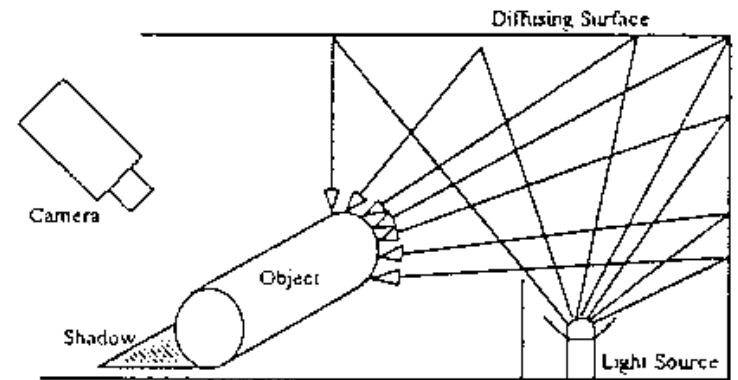
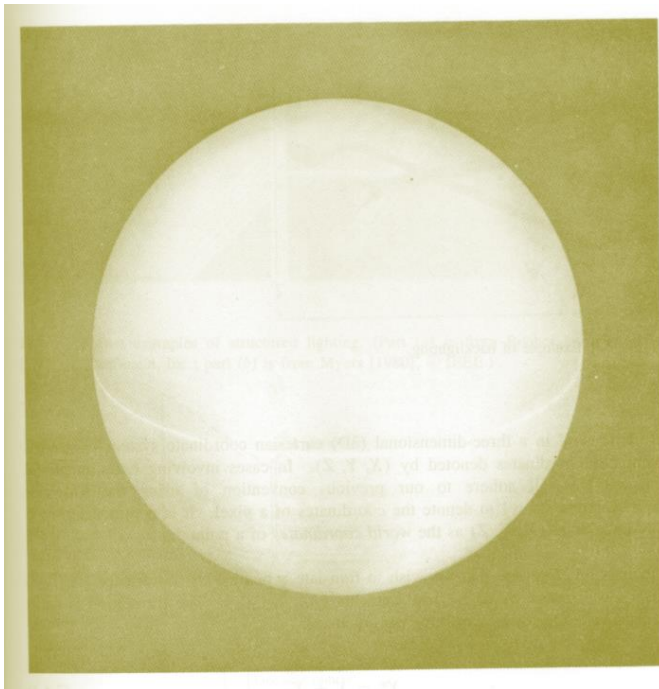

Diffuse-lighting technique

ILLUMINATION TECHNIQUES

2. BACKLIGHTING

- Produce black and white image. This technique suited for applications in which silhouettes of object are sufficient for recognition or other measurement.
- Example:

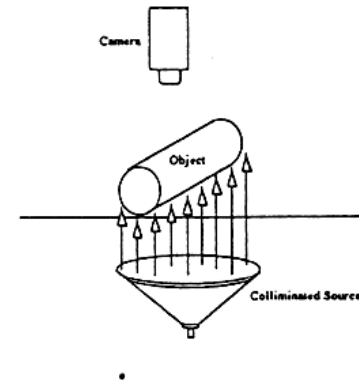
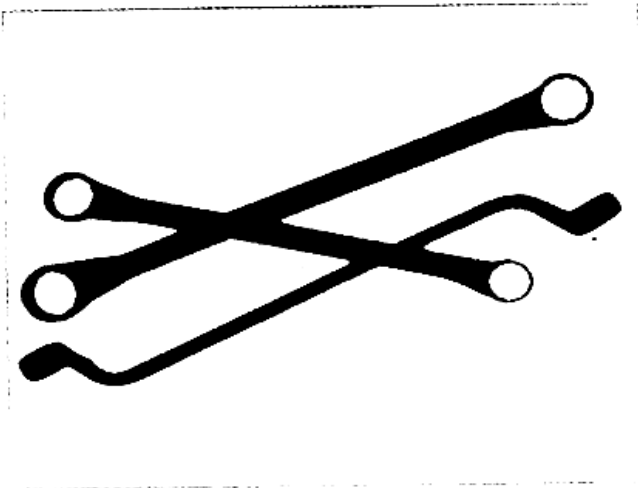

Backlighting technique

ILLUMINATION TECHNIQUES

3. STRUCTURED LIGHTING

- Consist of projecting points, stripes, grids onto work surface.
- This lighting technique has 2 important advantages:
 1. It establishes a known light pattern on the work space and disturbances of this indicate the presence of an object, thus simplifying the object detection problems.
 2. By analysing the way which the light pattern distorted, it is possible to gain insight into three-dimensional characteristics of the object.

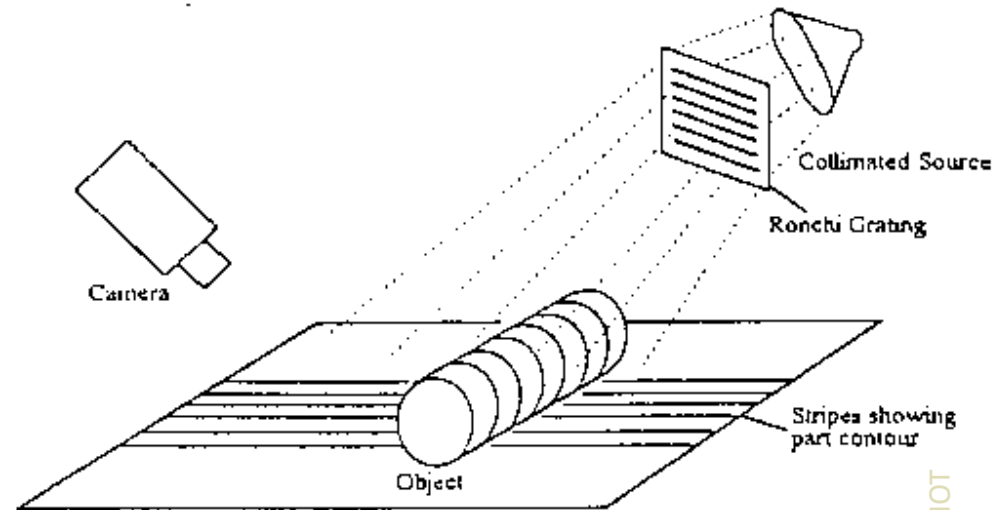

Structured lighting technique

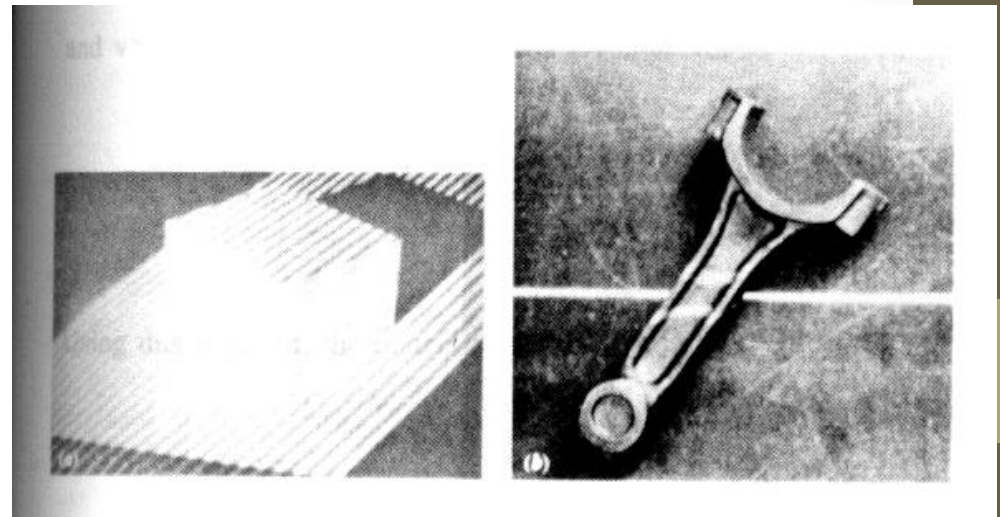

3. STRUCTURED LIGHTING (cont.)

- The following figure illustrates the structured lighting technique using two light planes projected from different directions, but converging on a single stripe on the surface. The two light sources guarantee that the object will break the light stripe only when it is directly below the camera.
- This technique is **suitable for moving object**.
- Note: “The line scan camera sees only the line on which the two light planes converge, but two-dimension information can be accumulated as the object move past the camera”

(b) Object will be seen by the camera only
When it interrupts both light planes

(a) Top view of two light planes intersecting in a line sight

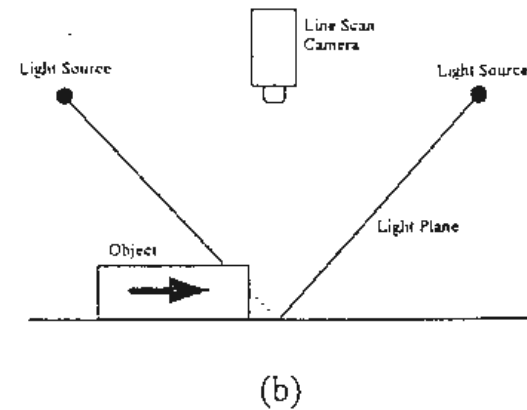
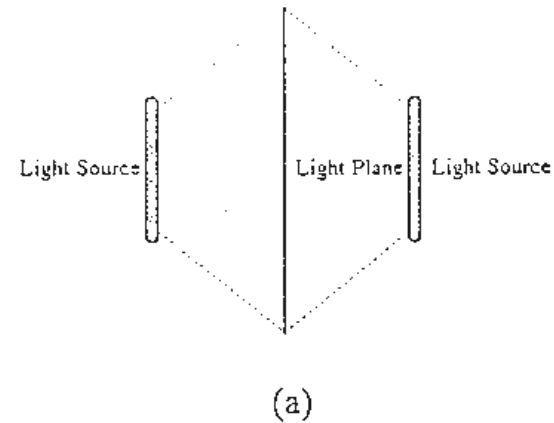

LUMINATION TECHNIQUES

DIRECTIONAL LIGHTING

- This method is used to inspection of object surfaces.
- Defects on the surface such as scratches, can be detected by using a highly directed light beam (such as laser beam) and measuring the amount of scatter

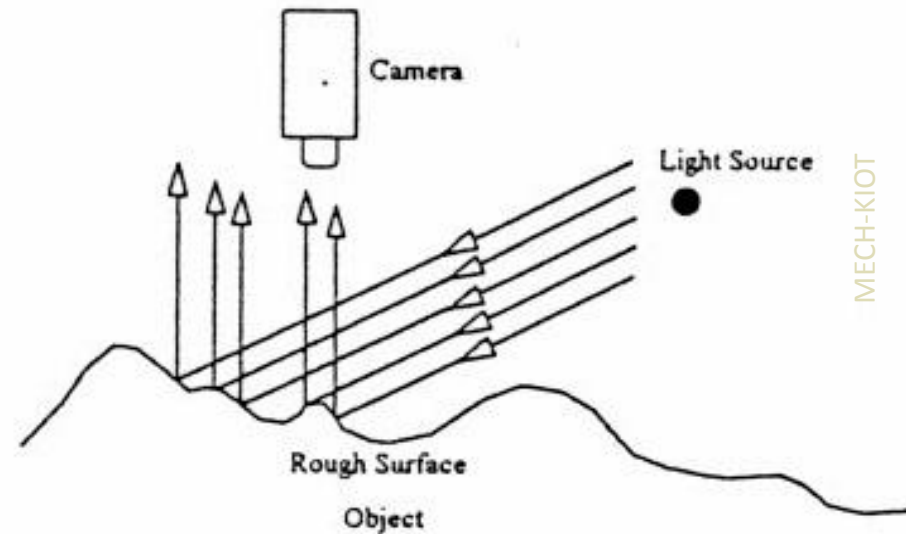

Directional lighting technique

ROBOT VISION SYSTEM

- There are several commercial packages that can be bought for vision processing work. A typical hardware configuration is shown below.
- Based on the technique used, the robotic vision systems can be grouped into the following major types:
 1. Binary vision systems
 2. Gray-level vision systems
 3. Ad hoc special-purpose vision systems
 4. Structured light vision systems
 5. Character recognition vision systems

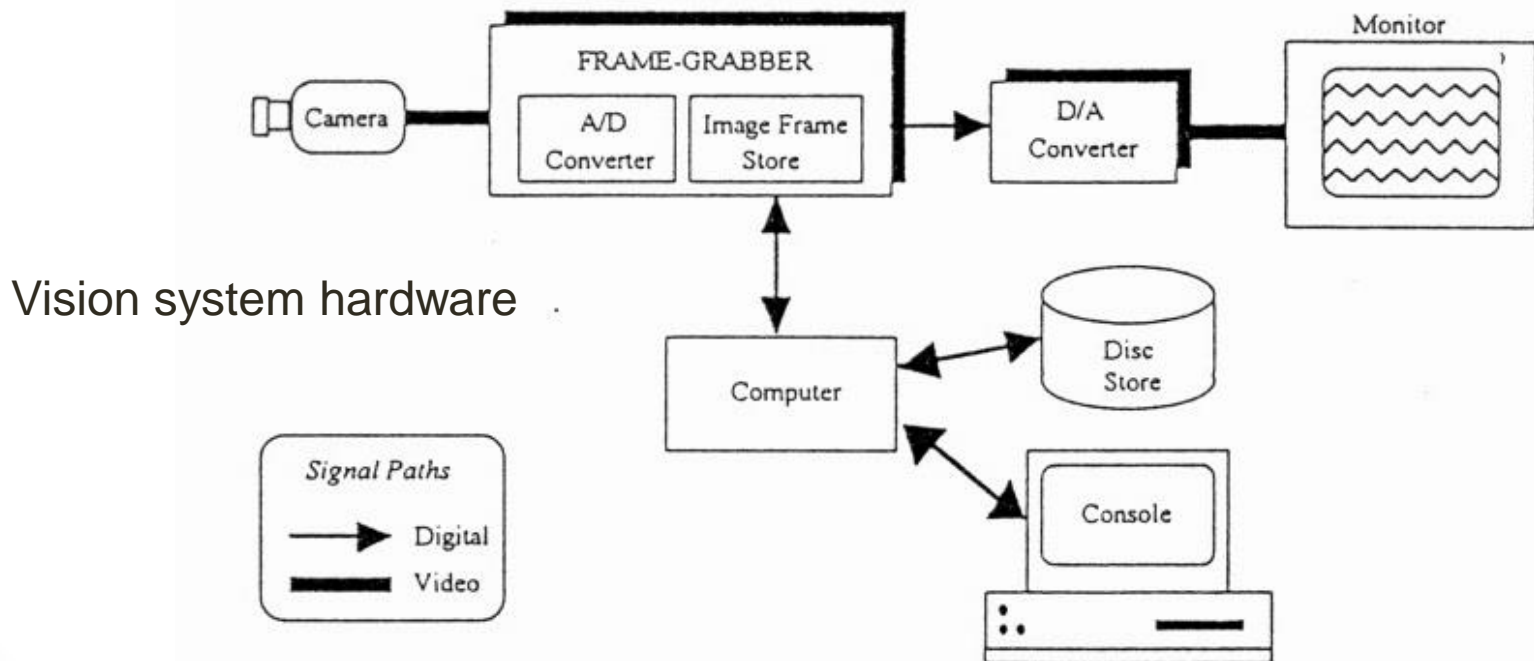

- A typical system will have facilities for controlling the camera remotely and perhaps interfaces for remote lighting control.
- The main problem with commercial vision packages is that they have to be general purpose in order to be applicable in many situations. This very requirement sometimes means that they are not suitable or are over complicated for a particular robot task in hand.
- In industrial robot world, vision is not used in an exploratory sense but is used to confirm or measure or refine existing known data.
- Whichever commercial vision system one purchases, one is likely to use it for applications such as those listed in the next section.

Vision Dev. Tools: Survey

- **Commercial products**

- Matrox: [MIL](#), [Inspector](#)
- Coreco Imaging: [Sapera](#), [MVTools](#), [WiT](#)
- MVTec: [Halcon](#)
- Euresys: [eVision](#), [EasyAccess](#)
- AAI: [Aphlion](#)

- **Free tools**

- Intel: [Open Source Computer Vision](#)
- Microsoft: [Vision SDK](#)
- XMegaWave: [XMegaWave](#)
- UTHSCSA: [ImageTool](#)

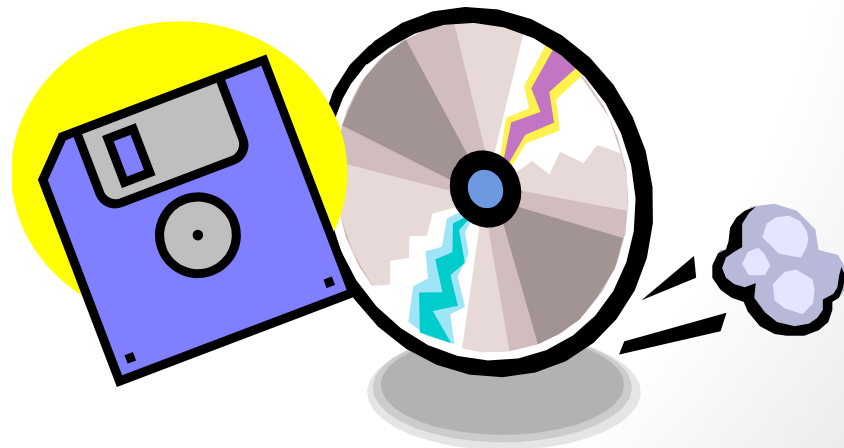

Slide borrowed from CAIRO

VISION APPLICATIONS

- 1. **OBJECT LOCATION**

Used in object handling and processing:

- Position
- Orientation

- 2. **OBJECT PROPERTIES**

Used in inspection, identification, measurement:

- Size
- Area

- Shape
- Periphery length / area ratio

- Texture
- Repetition of pattern

- Properties of internal features

- 3. **SPATIAL RELATIONS**

Used in measurement and task verification

- Relative positions

- Relative orientations
- Occlusions

- Alignments
- Connectivity

- 4. **ACTION MONITORING**

Used in actuator control and verification:

- Direct feedback
- Error measurement

- Action confirmation
- Inspection

- Collision avoidance planning.

MISCELLANEOUS SENSORS

POSITION, VELOCITY & ACCELERATION SENSORS

- There are several type of sensor that can be used to determine the position of robot joints like potentiometer, optical encoder, Linear Variable Differential Transformer (LVDT) Force & Torque Sensors.

Potentiometer

- Potentiometer transducers can be used to measure both linear and angular displacement

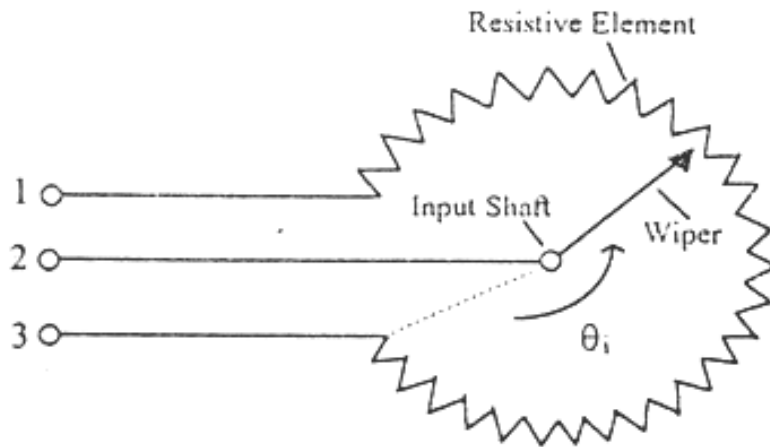

(a)

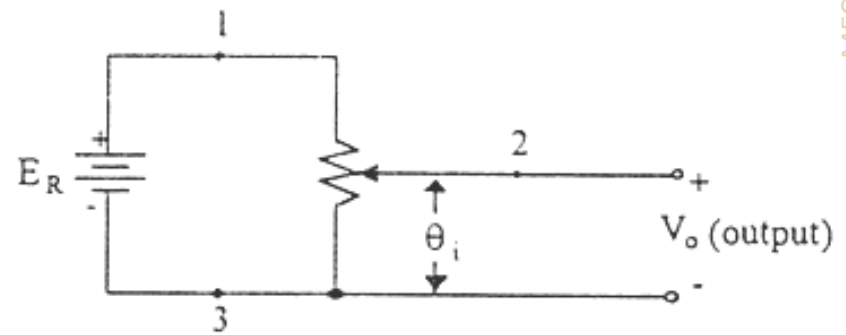

(b)

(a) Potentiometer

(b) Schematic diagram of the potentiometer

Linear Variable Differential Transformer (LVDT)

- LVDT is a robust and precise device which produce a voltage output proportional to the displacement of a ferrous armature for measurement of robot joints or end-effectors. It is much expensive but outperforms the potentiometer transducer.

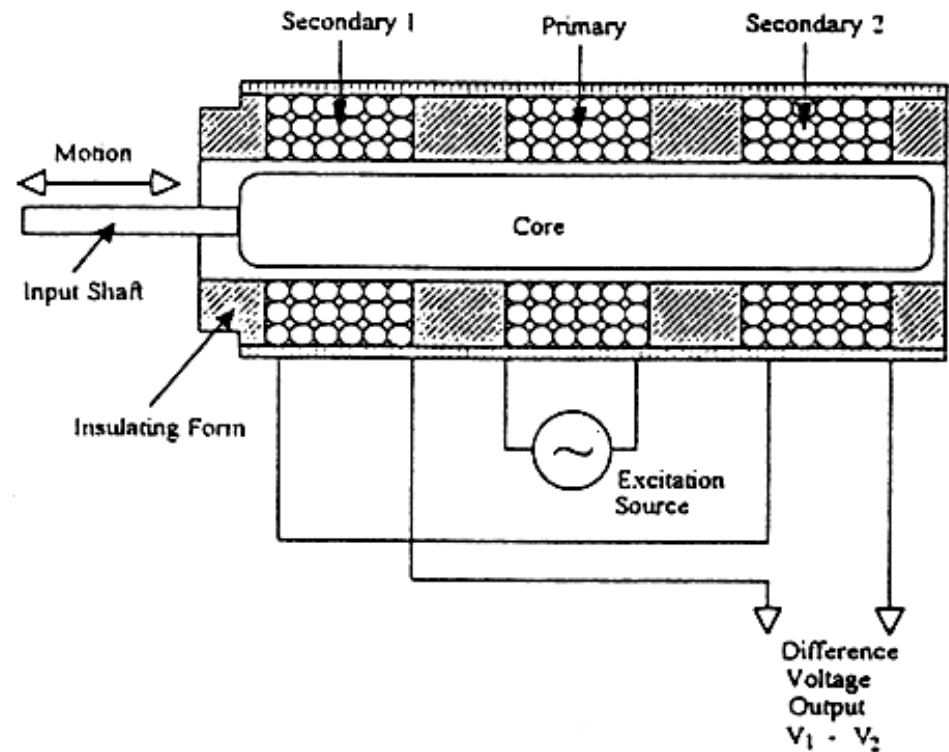

Linear Variable Differential Transformer (LVDT)

Force & Torque Sensors

- Force transducers are often based on displacement principle: There various type force and torque transducer available commercially

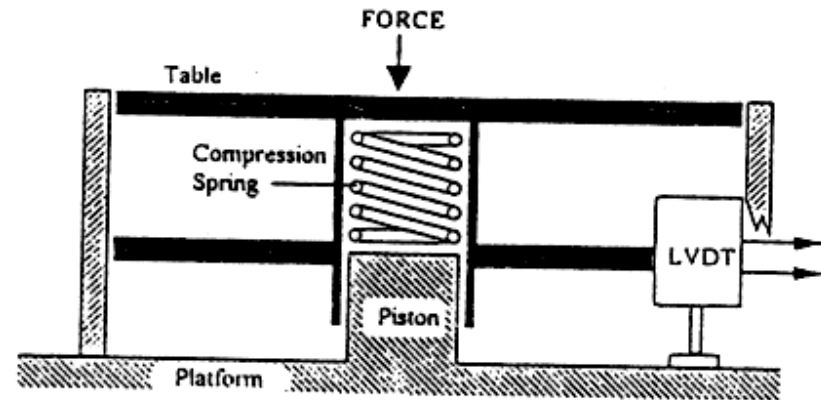

A force-measuring device based on a compression spring and LDVT.

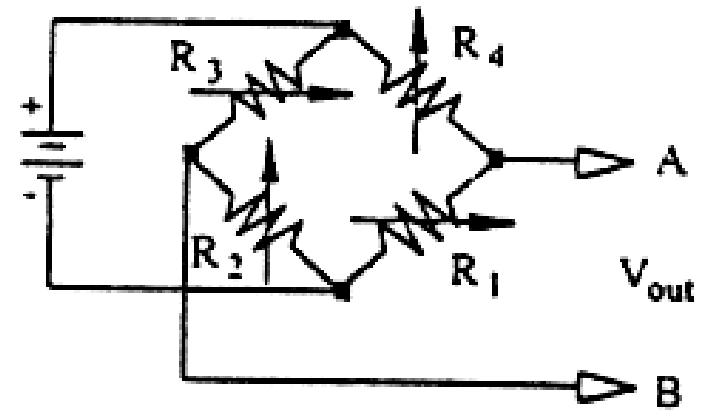
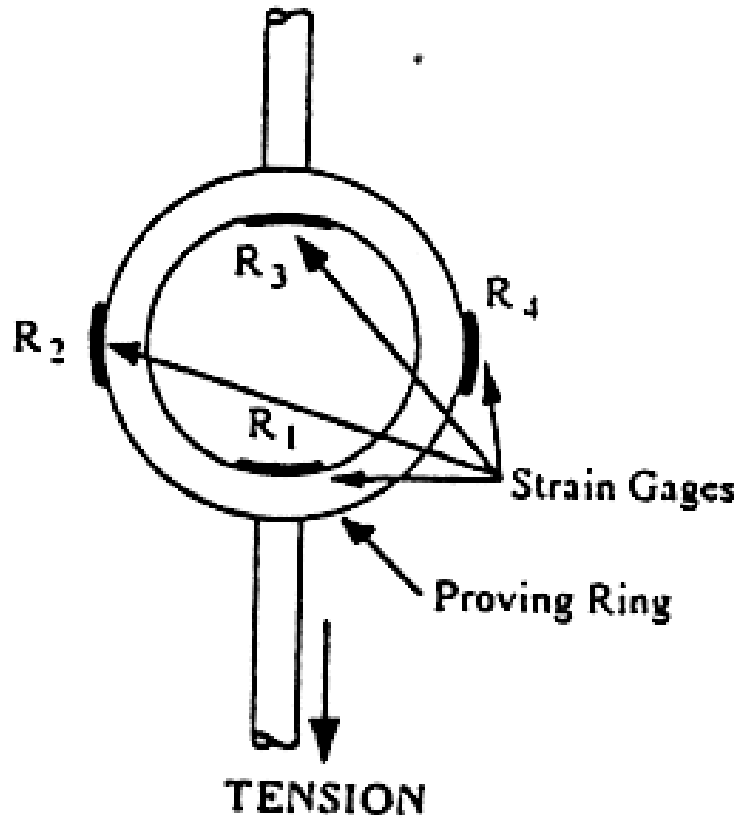

This figure illustrate a tension load cell.
 It can be used to measure the force
 required to pick up heavy load in industry

Force & Torque Sensors

- Force can be measured using piezoelectric principle.
- Figure shows a load washer type piezoelectric force transducer. It is designed to measure axial forces. It is preloaded when manufactured and can measure both tensile and compressive forces.

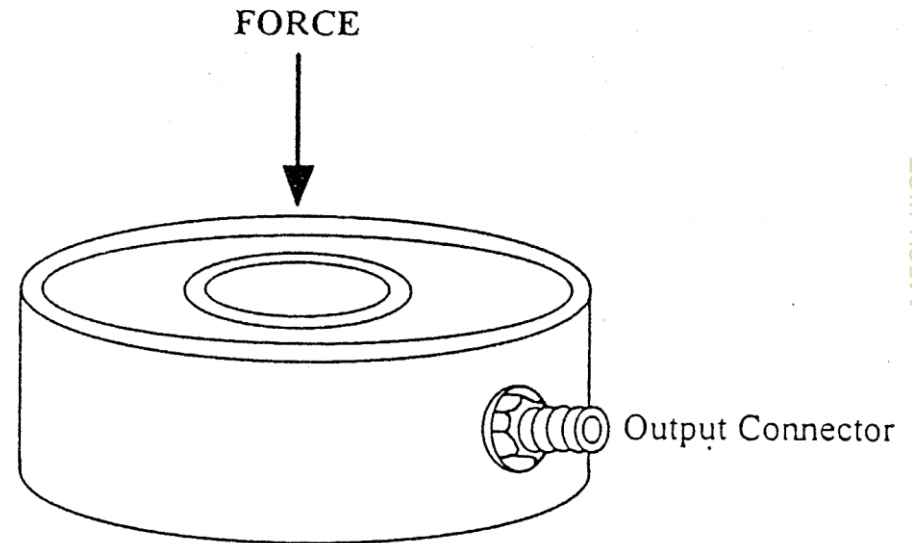

Force & Torque Sensors

- Measured using piezoelectric principle.
- Figure shows a three-component dynamometer type piezoelectric force transducer that measures three orthogonal components of force.

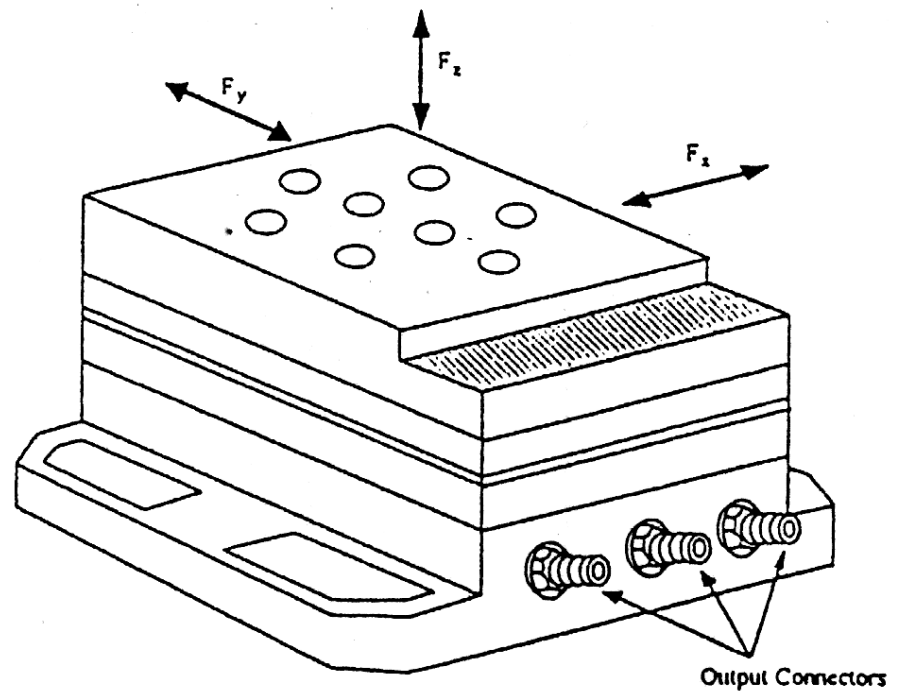

Motor Encoder

Incremental Optical Encoders

- Incremental Encoder:

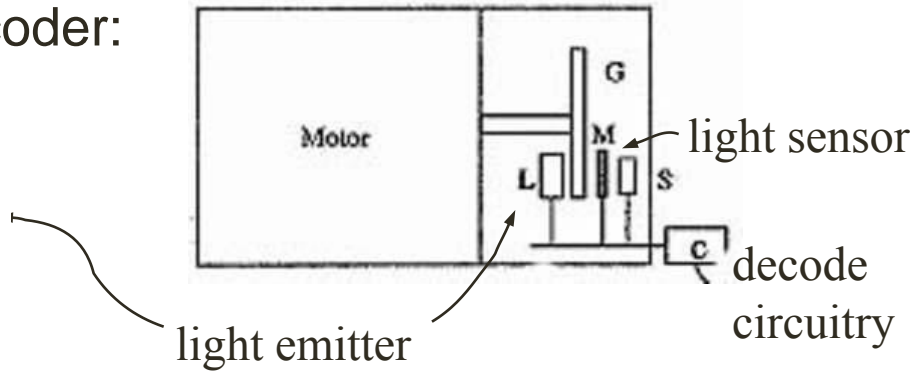
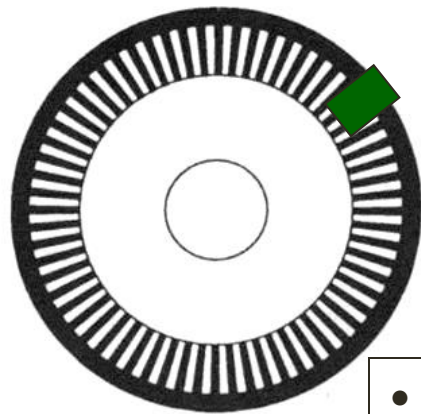

- direction
- resolution

- It generates pulses proportional to the rotation speed of the shaft.
- **Direction** can also be indicated with a two phase encoder:

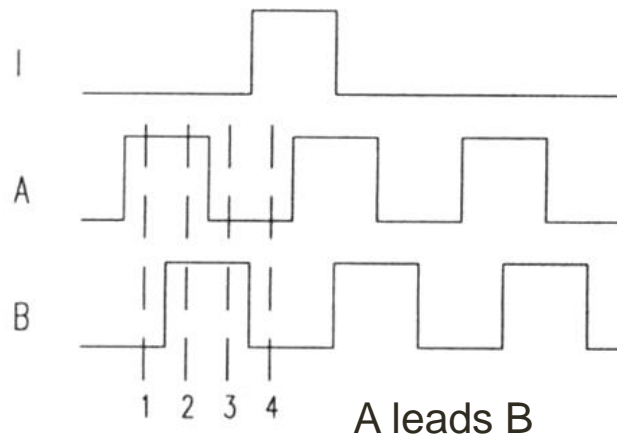
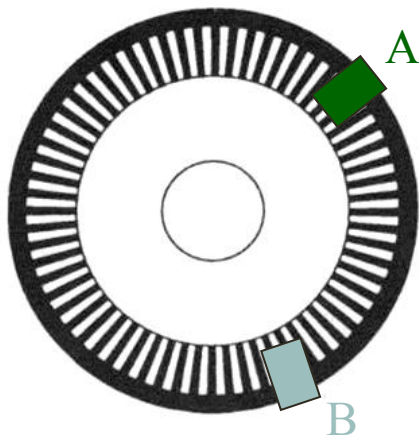

State	Ch A	Ch B
S ₁	High	Low
S ₂	High	High
S ₃	Low	High
S ₄	Low	Low

Absolute Optical Encoders

- Used when loss of reference is not possible.
- Gray codes: only one bit changes at a time (less uncertainty).
- The information is transferred in parallel form (many wires are necessary).

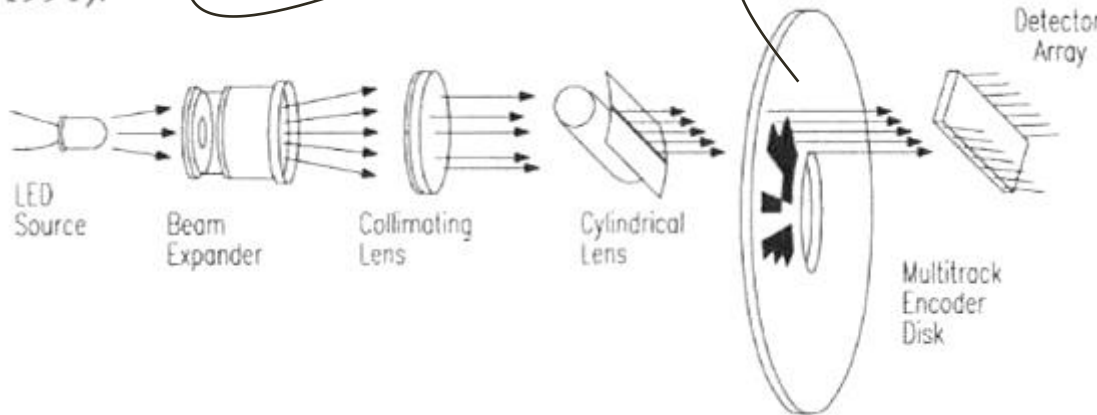
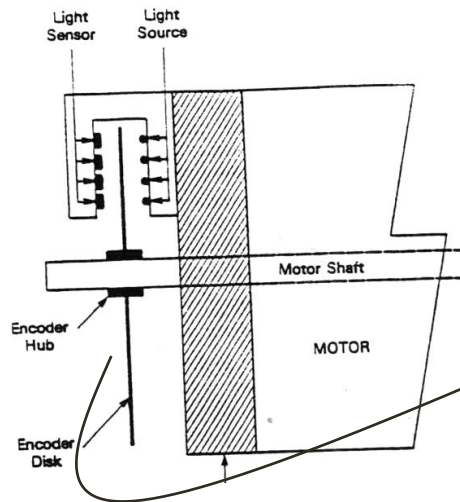

Binary	Gray Code
000	000
001	001
010	011
011	010
100	110
101	111
110	101
111	100

Other Odometry Sensors

• Resolver

It has two stator windings positioned at 90 degrees. The output voltage is proportional to the sine or cosine function of the rotor's angle. The rotor is made up of a third winding, winding C

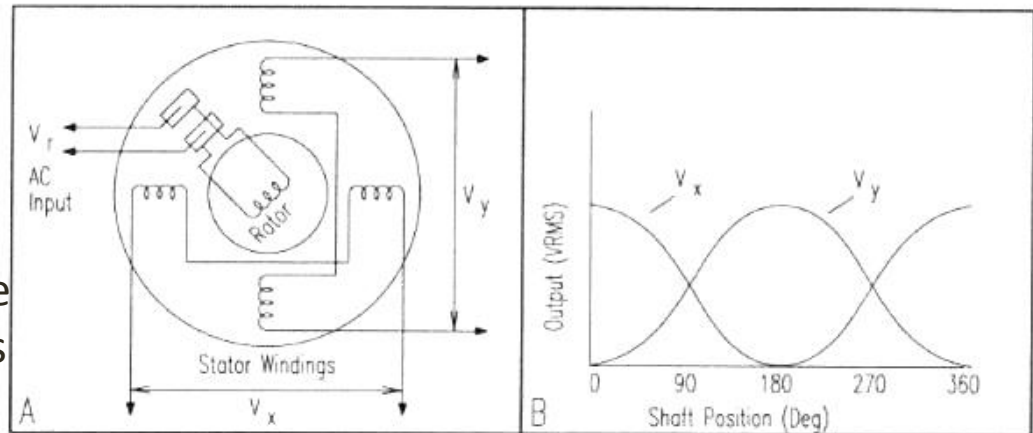

Figure 2-4. The outputs of the two orthogonal stator windings in a *resolver* are proportional to the sine and cosine of the applied rotor excitation (adapted from Tiwari, 1993).

• Potentiometer

= varying resistance

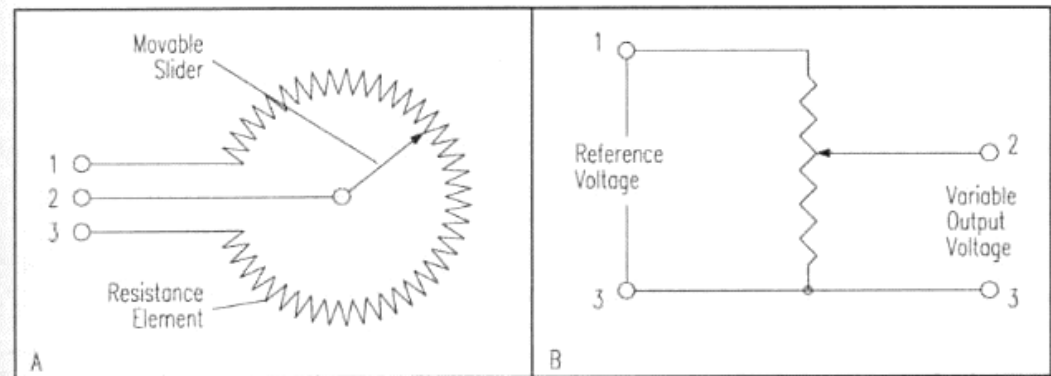

Figure 2-1. For a linear-taper pot, the output voltage V_o is directly related to the ratio of actual to full scale displacement.

Inertial Sensors

- **Gyroscopes**
 - Measure the rate of rotation independent of the coordinate frame
 - Common applications:
 - Heading sensors, Full Inertial Navigation systems (INS)
- **Accelerometers**
 - Measure accelerations with respect to an inertial frame
 - Common applications:
 - Tilt sensor in static applications, Vibration Analysis, Full INS Systems

Accelerometers

- They measure the inertia force generated when a mass is affected by a change in velocity.
- This force may change
 - The tension of a string
 - The deflection of a beam
 - The vibrating frequency of a mass

Accelerometer

- Main elements of an accelerometer:
 1. Mass
 2. Suspension mechanism
 3. Sensing element

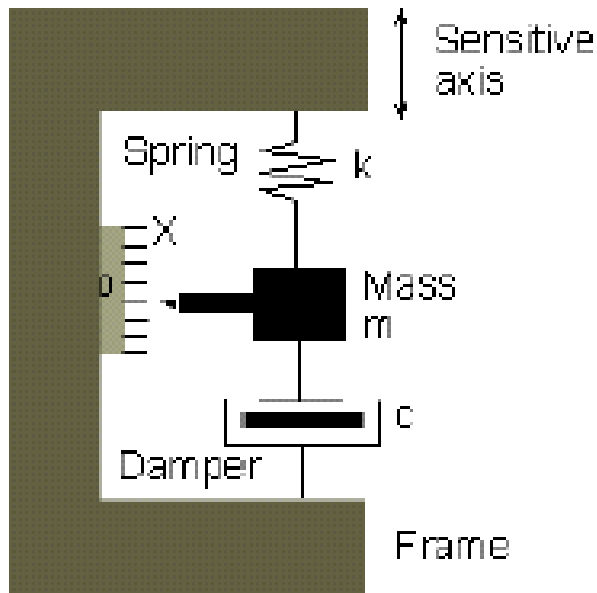

$$F = m \frac{d^2 x}{d^2 t} + c \frac{dx}{dt} + kx$$

High quality accelerometers include a servo loop to improve the linearity of the sensor.

Gyroscopes

- These devices return a signal proportional to the rotational velocity.
- There is a large variety of gyroscopes that are based on different principles

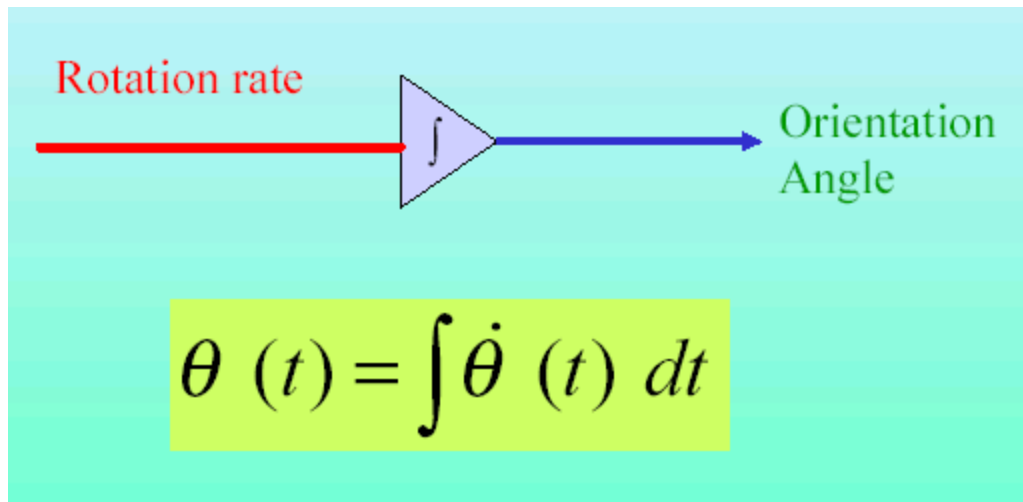

Global Positioning System (GPS)

24 satellites (+several spares)

broadcast time, identity, orbital parameters (latitude, longitude, altitude)

Space Segment

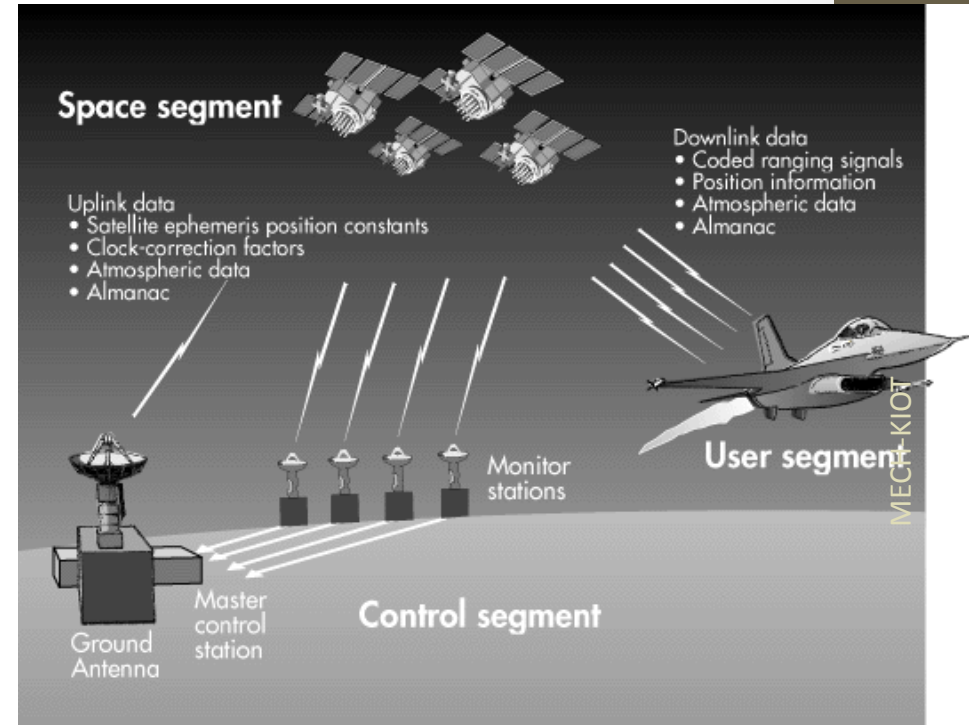

<http://www.cnde.iastate.edu/staff/swormley/gps/gps.htm>

Global Positioning System (GPS)

24 satellites (+several spares)

broadcast time, identity, orbital parameters (latitude, longitude, altitude)

Space Segment

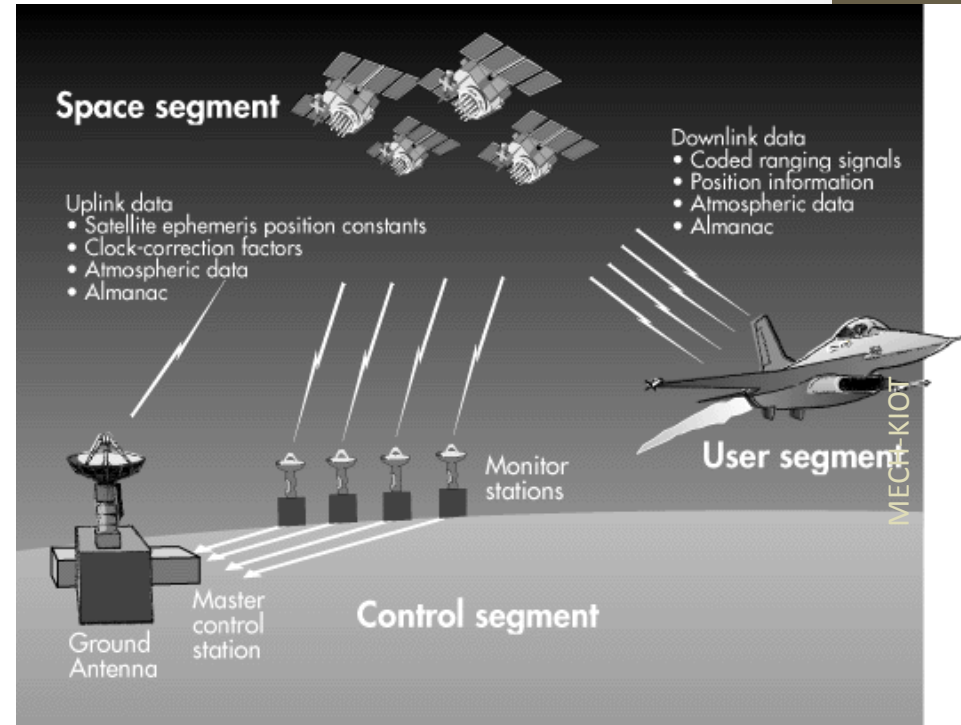

<http://www.cnde.iastate.edu/staff/swormley/gps/gps.htm>

Noise Issues

- Real sensors are noisy
- Origins: natural phenomena + less-than-ideal engineering
- Consequences: limited accuracy and precision of measurements
- Filtering:
 - software: averaging, signal processing algorithm
 - hardware tricky: capacitor