

Rosemount™ 1408H Level Transmitter

Non-Contacting Radar



1 About this guide

This Quick Start Guide provides basic guidelines for the Rosemount 1408H Level Transmitter. Refer to the 1408H [Reference Manual](#) for more instructions.

1.1 Safety messages

⚠ WARNING

Failure to follow safe installation and servicing guidelines could result in death or serious injury.

Ensure the transmitter is installed by qualified personnel and in accordance with applicable code of practice.

Use the equipment only as specified in this Quick Start Guide and the Reference Manual. Failure to do so may impair the protection provided by the equipment.

Repair, e.g. substitution of components, etc. may jeopardize safety and is under no circumstances allowed.

⚠ WARNING

Process leaks could result in death or serious injury.

Handle the transmitter carefully.

Install and tighten process connectors before applying pressure.

Do not attempt to loosen or remove process connectors while the transmitter is in service.

⚠ WARNING

Physical access

Unauthorized personnel may potentially cause significant damage to and/or misconfiguration of end users' equipment. This could be intentional or unintentional and needs to be protected against.

Physical security is an important part of any security program and fundamental to protecting your system. Restrict physical access by unauthorized personnel to protect end users' assets. This is true for all systems used within the facility.

⚠ CAUTION

Hot surfaces

The transmitter and process seal may be hot at high process temperatures. Allow to cool before servicing.



Note

Be careful not to scratch or otherwise damage the PTFE sealing.

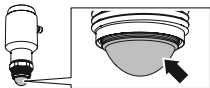

2 Cleaning the transmitter

Procedure

If needed, clean the wetted parts of the transmitter.

Use a damp cloth and a mild cleaning agent suitable for the media and wetted parts of the transmitter.

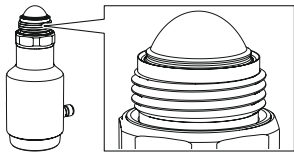

Note

Be careful not to scratch any of the surfaces.

3 Installing on a tank

3.1 Mount the Tri Clamp version

Procedure

1. Place a suitable gasket on top of the tank flange.

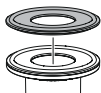

2. Lower the transmitter into the nozzle.

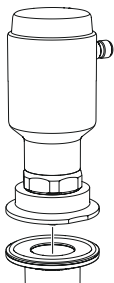

3. Tighten the clamp to the recommended torque (see the manufacturer's instruction manual).

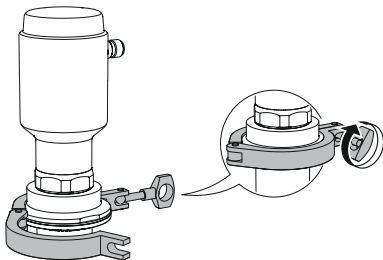

3.2 Mount the dairy coupling (DIN 11851)

Procedure

1. Place a suitable gasket on top of the tank flange.

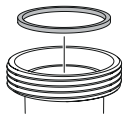

2. Lower the transmitter into the nozzle.

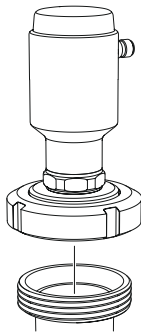

3. Tighten the lock nut to the recommended torque (see the manufacturer's instruction manual).

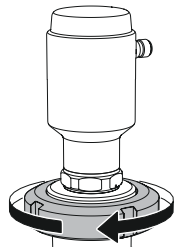

3.3 Mount the VARIVENT® version

Procedure

1. Mount a suitable O-ring on the adapter.

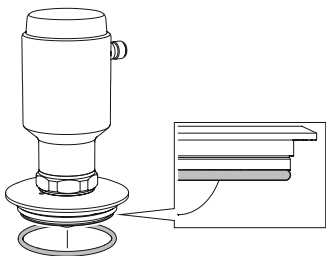

2. Lower the transmitter into the nozzle.

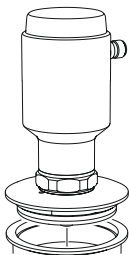

3. Tighten the clamp to the recommended torque (see the manufacturer's instruction manual).

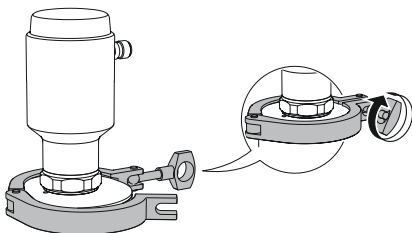

3.4 Mount on a threaded connection

Procedure

1. Apply lubricating paste on the transmitter thread.

Note

The paste must be approved for the application and compatible with the elastomers used.

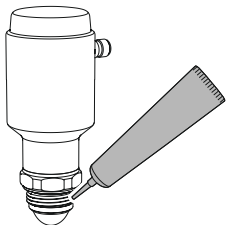

2. Mount the transmitter on the tank.

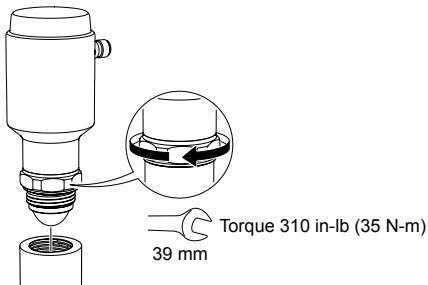

3.4.1 Thread engagement length

Refer to [Figure 3-1](#) for the required thread engagement length at the customer G1 process connection.

Figure 3-1: Thread Engagement Length

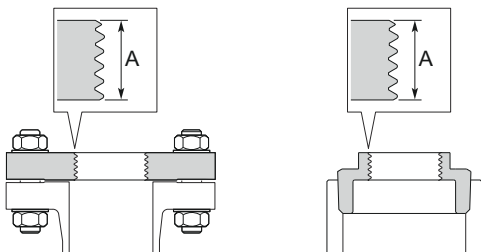

A. 0.35 to 0.63 in. (9 to 16 mm)

4 Bracket mounting

4.1 Bracket hole pattern

Figure 4-1: Hole Pattern

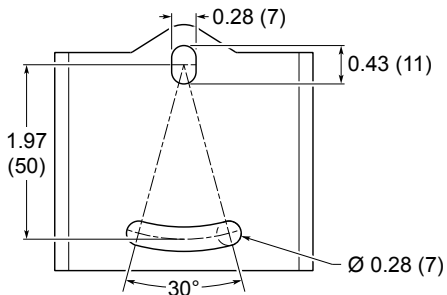

Dimensions are in inches (millimeters).

4.2 Mount the bracket

Procedure

1. Mount the bracket on the wall/ceiling or other flat surface.

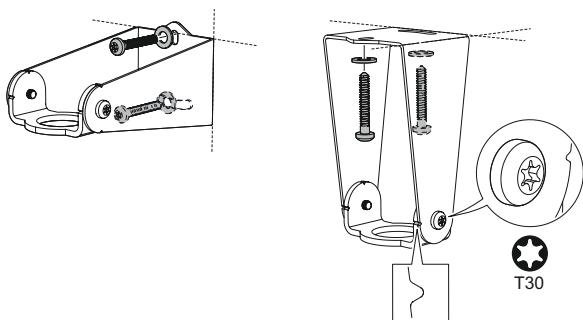

2. Ensure the adjustable holder is directed toward the ground.

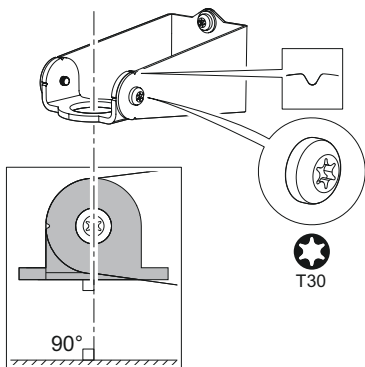

3. Apply lubricating paste on the transmitter thread.

Note

The paste must be approved for the application and compatible with the elastomers used.

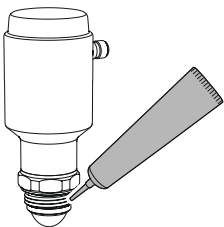

4. Secure the transmitter to the bracket.

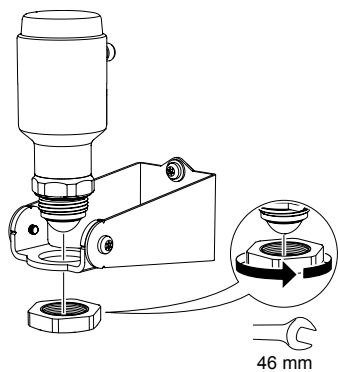

5 Prepare the electrical connections

5.1 Connector type

M12 (A-coded)

5.2 Power supply

The transmitter operates on 18-30 Vdc at the transmitter terminals.

5.3 Outputs

The transmitter provides two configurable outputs:

Output 1 Digital output / IO-Link mode

Output 2 Digital output or active 4-20 mA analog output

5.4 Internal power consumption

< 2 W (normal operation at 24 Vdc, no outputs)

< 3.6 W (normal operation at 24 Vdc, digital and analog outputs active)

5.5 Wiring diagram

Figure 5-1: Connection

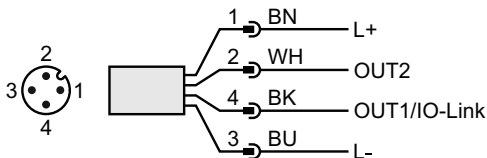
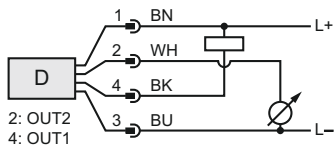
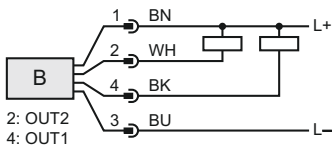
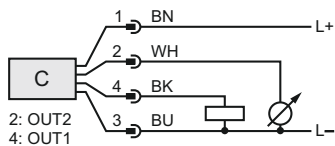
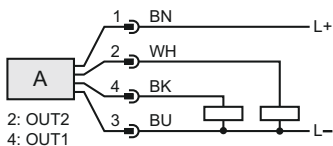

Table 5-1: Pin Assignment

Pin	Wire color ⁽¹⁾		Signal	
1	BN	Brown	L+	24 V
2	WH	White	OUT2	Digital output or active 4-20 mA analog output
3	BU	Blue	L-	0 V
4	BK	Black	OUT1/IO-Link	Digital output or IO-Link mode

(1) According to IEC 60947-5-2.

Figure 5-2: Example Circuits



- A. 2 x Digital output PnP
- B. 2 x Digital output NpN
- C. 1 x Digital output PnP / 1 x Analog output
- D. 1 x Digital output NpN / 1 x Analog output

6 Power up transmitter

Procedure

1. ⚠ Verify the power supply is disconnected.
2. Insert the M12 connector and screw tight.
See the manufacturer's instruction manual for recommended torque.

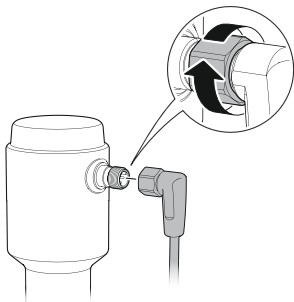

3. Connect the power supply.

7 Connect the transmitter to the IO-Link

IO-Link devices can be set using an IO-Link USB Communicator, through the IO-Link master, or via the PLC.

Procedure

Start the configuration software and connect the transmitter.

Figure 7-1: Connection via the IO-Link USB Communicator

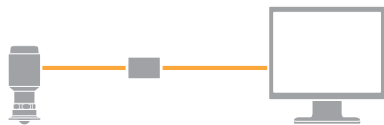

Figure 7-2: Connection via the IO-Link Master

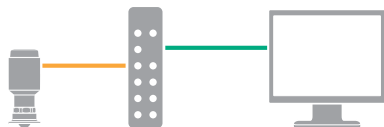

Figure 7-3: Connection via the PLC



8 Get started with your preferred configuration tool

8.1 IO-Link configuration tools

Examples:

- Rosemount IO-Link Assistant (available as accessory)
- FDT[®] frame applications, e.g. PACTware

8.2 Rosemount IO-Link Assistant

8.2.1 Get the latest IODD files

The Rosemount IO-Link Assistant software checks and lets you download the latest IODDs for your device catalog.

Prerequisites

For an online update, an internet connection is required.

Procedure

1. Click the  icon.
2. In the **Vendor** list, select **Rosemount Inc.**, and then select the check box for the devices to be installed/updated.
Alternatively, browse to an already downloaded IODD zip file, and select **Open**.
3. Select **OK**.

8.3 FDT[®]/DTM framework

8.3.1 Download the IODD file

Procedure

1. Download the IODD from the IODDFinder portal at ioddfinder.io-link.com.
2. Unzip the IODD package.

8.3.2 Integrate IODDs into an FDT®/DTM framework

An IODD DTM Interpreter is required to integrate IODDs into an FDT/DTM environment (e.g PACTware).

Prerequisites

The IODD DTM Interpreter is usually included in the FDT/DTM software installation package. It can also be downloaded from Emerson.com/Rosemount1408H.

Procedure

1. Start the **IODD DTM Interpreter** software.
2. Select **Add IODD**.

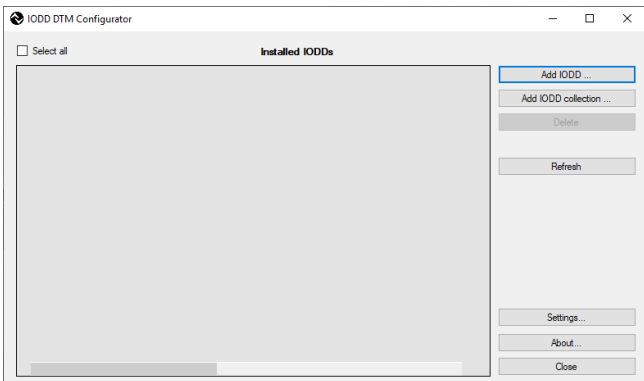

3. Browse to the IODD file (.xml) and select **Open**.
4. Start the configuration tool and update the device catalog.

Need help?

If the new DTM is not added automatically at start-up, then select **View** → **Device Catalog** → **Update Device Catalog**.

9 Perform the basic setup

9.1 Set the engineering units

Procedure

1. Under **Menu**, select **Parameter** → **Basic Setup**.
2. In the **Engineering Units** list, select **Metric** or **Imperial**.
3. Select **Write to device**.

9.2 Enter the reference height

Procedure

1. Under **Menu**, select **Parameter** → **Basic Setup**.
2. Enter the Reference Height.
3. Select **Write to device**.

9.2.1 Reference height

Distance between the Device Reference Point and Zero Level.

Figure 9-1: Reference Height

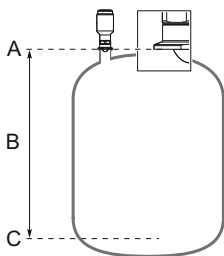

- A. Device Reference Point
 - B. Reference Height
 - C. Zero Level
-

9.3 Configure the analog output

The transmitter can be set to output the level as a 4-20 mA signal.

Procedure

1. Under **Menu**, select **Parameter** → **Basic Setup**.
2. In the **OUT2 Configuration** list, select **Analog Output 4-20 mA**.
3. Select **OUT2** → **Analog Output 2**.
4. Enter the desired Upper Range Value (20 mA).
5. Enter the desired Lower Range Value (4 mA).
6. In the **Alarm Mode** list, select **Low Alarm** or **High Alarm**.
7. Select **Write to device**.

9.4 Configure the digital output

The transmitter can be set to output a switching signal for high and low level limits (using the same pin).

Procedure

1. Under **Menu**, select **Parameter** → **Basic Setup**.
2. In the **OUT1 Configuration** or **OUT2 Configuration** list, select **Digital Output Normally Open**.
3. In the **Digital Outputs P-n** list, select **PnP** or **nPn**.
4. Select **Digital Output 1** or **Digital Output 2**.
5. Set the alarm parameters as desired.
6. Select **Write to device**.

10 Product certifications

Rev 2.2

10.1 European directive information

A copy of the EU Declaration of Conformity can be found at the end of the document. The most recent revision of the EU Declaration of Conformity can be found at Emerson.com/Rosemount.

10.2 UK regulation information

A copy of the UKCA Declaration of Conformity can be found at the end of the document. The most recent revision of the UKCA Declaration of Conformity can be found at Emerson.com/Rosemount.

10.3 Ordinary location certification

As standard, the transmitter has been examined and tested to determine that the design meets the basic electrical, mechanical, and fire protection requirements by a nationally recognized test laboratory (NRTL) as accredited by the Federal Occupational Safety and Health Administration (OSHA).

Certificate 80031621

Standards CAN/CSA-C22.2 No. 61010-1-12,
UL Std. No. 61010-1

The device may only be powered by a power supply unit with a limited energy electric circuit max. 30 Vdc output in accordance with CAN/CSA-C22.2 No. 61010-1-12 / UL Std. No. 61010-1 (3rd Edition) chapter 6.3.1/6.3.2 and 9.4 or class 2 according to CSA 223/UL 1310.

10.4 Environmental conditions

Table 10-1: Environmental Conditions (Ordinary Location and Low Voltage Directive (LVD))

Type	Description
Location	Indoor or outdoor use ⁽¹⁾
Maximum altitude	6562 ft. (2000 m)
Ambient temperature	-40 to 176 °F (-40 to 80 °C)
Installation category	DC supplied
Electrical supply	18-30 Vdc, 3.6 W
Mains supply voltage fluctuations	Safe at 18-30 Vdc \pm 10%
Pollution degree	2

(1) Outdoor use not part of Ordinary Location certification.

10.5 Telecommunication compliance

Measurement principle

Frequency Modulated Continuous Wave (FMCW), 80 GHz

Maximum output power

3 dBm (2 mW)

Frequency range

77 to 81 GHz

TLPR (Tank Level Probing Radar)

TLPR (Tank Level Probing Radar) equipment are devices for measurement of level in a closed space only (i.e metallic or reinforced concrete or fiberglass tanks, or similar enclosure structures made of

comparable attenuating material). Rosemount 1408H is TLPR device. Hardware Version Identification Number (HVIN) is 1408T.

10.6 FCC

Note: This equipment has been tested and found to comply with the limits for a Class B digital device, pursuant to part 15 of the FCC Rules. These limits are designed to provide reasonable protection against harmful interference in a residential installation. This equipment generates, uses and can radiate radio frequency energy and, if not installed and used in accordance with the instructions, may cause harmful interference to radio communications. However, there is no guarantee that interference will not occur in a particular installation. If this equipment does cause harmful interference to radio or television reception, which can be determined by turning the equipment off and on, the user is encouraged to try to correct the interference by one or more of the following measures:

- Reorient or relocate the receiving antenna.
- Increase the separation between the equipment and receiver.
- Connect the equipment into an outlet on a circuit different from that to which the receiver is connected.
- Consult the dealer or an experienced radio/TV technician for help.

FCC ID K8C1408T

10.7 IC

This device complies with Industry Canada's licence-exempt RSS standard. Operation is subject to the following conditions:

1. This device may not cause harmful interference.
2. This device must accept any interference received, including interference that may cause undesired operation.

3. The installation of the TLPR device shall be done by trained installers in strict compliance with the manufacturer's instructions.
4. The use of this device is on a "no-interference, no-protection" basis. That is, the user shall accept operations of high-powered radar in the same frequency band which may interfere with or damage this device. However, devices found to interfere with primary licensing operations will be required to be removed at the user's expense.
5. This device shall be installed and operated in a completely enclosed container to prevent RF emissions, which can otherwise interfere with aeronautical navigation.
6. The installer/user of this device shall ensure that it is at least 10 km from the Dominion Astrophysical Radio Observatory (DRAO) near Penticton, British Columbia. The coordinates of the DRAO are latitude 49°19'15"N and longitude 119°37'12" W. For devices not meeting this 10 km separation (e.g., those in the Okanagan Valley, British Columbia,) the installer/user must coordinate with, and obtain the written concurrence of, the Director of the DRAO before the equipment can be installed or operated. The Director of the DRAO may be contacted at 250-497-2300 (tel.) or 250-497-2355 (fax). (Alternatively, the Manager, Regulatory Standards, Industry Canada, may be contacted.)

Le présent appareil est conforme aux CNR d'Industrie Canada applicables aux appareils radio exempts de licence. L'exploitation est autorisée aux conditions suivantes:

1. l'appareil ne doit pas produire de brouillage.
2. l'appareil doit accepter tout brouillage radioélectrique subi, même si le brouillage est susceptible d'en compromettre le fonctionnement.

3. L'installation d'un dispositif TLPR doit être effectuée par des installateurs qualifiés, en pleine conformité avec les instructions du fabricant.
4. Ce dispositif ne peut être exploité qu'en régime de non-brouillage et de non-protection, c'est-à-dire que l'utilisateur doit accepter que des radars de haute puissance de la même bande de fréquences puissent brouiller ce dispositif ou même l'endommager. D'autre part, les capteurs de niveau qui perturbent une exploitation autorisée par licence de fonctionnement principal doivent être enlevés aux frais de leur utilisateur.
5. Un dispositif visé comme TLPR doit être installé et exploité dans un réservoir entièrement fermé afin de prévenir les rayonnements RF qui pourraient autrement perturber la navigation aérienne.
6. La personne qui installe/utilise ce capteur de niveau doit s'assurer qu'il se trouve à au moins 10 km de l'Observatoire fédéral de radioastrophysique (OFR) de Penticton en Colombie-Britannique. Les coordonnées de l'OFR sont: latitude N 49° 19' 15", longitude O 119° 37' 12". La personne qui installe/utilise un dispositif ne pouvant respecter cette distance de 10 km (p. ex. dans la vallée de l'Okanagan [Colombie-Britannique]) doit se concerter avec le directeur de l'OFR afin d'obtenir de sa part une autorisation écrite avant que l'équipement ne puisse être installé ou mis en marche. Le directeur de l'OFR peut être contacté au 250-497-2300 (tél.) ou au 250-497-2355 (fax). (Le Directeur des Normes réglementaires d'Industrie Canada peut également être contacté).

10.8 Radio Equipment Directive (RED) 2014/53/EU and Radio Equipment Regulations S.I. 2017/1206

Rosemount 1408H complies with ETSI EN 302 372 (TLPR) and EN 62311.

TLPR (Tank Level Probing Radar)

The device must be installed in closed tanks. Install according to requirements in ETSI EN 302 372 (Annex E).

Performance under the influence of an interferer signal

For the receiver test that covers the influence of an interferer signal to the device, the performance criterion has at least the following level of performance according to ETSI TS 103 361 [6].

- Performance criterion: measurement value variation Δd over time during a distance measurement
- Level of performance: $\Delta d \leq \pm 2 \text{ mm}$

10.9 Radio/EMC Republic of Korea

Registration number R-R-Rtr-1408

10.10 Radio/EMC Australia and New Zealand

Rosemount 1408H complies with the requirements of the relevant ACMA Standards made under the Radiocommunications Act 1992 and the Telecommunications Act 1997 and the relevant Standards made under The New Zealand Radio Communication Act 1989.

10.11 Canadian Registration Number (CRN)

Transmitter without adapter

Registrations Alberta (ABSA): 0F21418.2
British Columbia (TSBC): 0F7358.1

Manitoba (ITS): 0F21418.24
New Brunswick: 0F21418.27
Newfoundland and Labrador: 0F21418.20
Northwest Territories: 0F21418.2T
Nova Scotia: 0F21418.28
Nunavut: 0F21418.2N
Ontario (TSSA): 0F23714.5
Prince Edward Island: 0F21418.29
Québec (RBQ): 0F05457.6
Saskatchewan (TSASK): 0F2113.3
Yukon: 0F21418.2Y

Hygienic adapters

Option code CA (part FB-1001), C2 (part FB-1002), WD (part FB-1041)

Registration All provinces except Alberta: 0F15548

The hygienic adapters are registered for a max temperature of 248 °F (120 °C).

10.12 Hygienic certificates and approvals

10.12.1 3-A[®]

**Certificate
Authorization
Number** 3626

Standard 3-A Sanitary Standards for Number 74-07
(Sensors and Sensor Fittings and Connections)

10.12.2 EHEDG

Certificate Number EHEDG-C2200003

Certification Type EL CLASS I

10.12.3 Other hygienic approvals

The process wetted components comply with:

- FDA 21 CFR 110, subpart C
- EC 1935/2004
- TSE/BSE Free

10.12.4 Instructions for hygienic installations

To conform with applicable hygienic standards and food and beverage legislation and regulations, the Rosemount 1408H must be:

- Installed in a closed tank.
- Installed with hygienic adapter and O-ring.

It is the responsibility of the user to ensure that:

- The materials listed in [Table 10-2](#) and [Table 10-3](#) are suitable for the media and cleaning/sanitizing processes.
- The installation of the transmitter is drainable and cleanable.
- The joint/clamping between the transmitter and the nozzle is compatible with the tank pressure and media.
- For the application a suitable M12 connector is used and with appropriate ingress protection.
- The product contact surfaces are not scratched.

3-A® installations only

It is the responsibility of the user to ensure that:

- The hygienic adapter is 3-A certified and approved for use with the transmitter.
- The fittings and connections comply with the requirements of 3-A Sanitary Standard 63-.
- Correct gasket variants are used on the “product contact side”, and that they are made of 3-A compliant product contact material.
- The 3-A specific nozzle height limits are kept to ensure cleanability. See [Reference Manual](#) for nozzle requirements.

EHEDG installations only

It is the responsibility of the user to ensure that:

- The hygienic adapter is EHEDG certified and approved for use with the transmitter.
- The seals/gaskets used conform to the EHEDG Position Paper “Easy cleanable pipe couplings and process connections”. Note that a special gasket is required for Tri Clamp connections, as specified in the EHEDG Position Paper.
- The installation of the transmitter is drainable in accordance with EHEDG Doc. 8 "Hygienic Design Principles" and is evaluated for cleanability according to EHEDG Doc. 2.
- The EHEDG specific nozzle height limits are kept to ensure cleanability. See [Reference Manual](#) for nozzle requirements.

Materials of construction

The hygienic approvals and certificates of the transmitter rely upon the following materials used in its construction:

Table 10-2: Product Contact Surfaces

Item	Material	Compliant with
PTFE sealing	PTFE fluoropolymer	21 CFR 177.1550 EC 10/2011 TSE/BSE Free USP<87> USP<88> Class VI
Hygienic adapter	Stainless steel 300 series	TSE/BSE Free
Hygienic adapter O-ring ⁽¹⁾	EPDM or FKM	21 CFR 177.2600 TSE/BSE Free USP<87> USP<88> Class VI

(1) Only the EPDM O-ring is EHEDG approved.

Table 10-3: Nonproduct Contact Surfaces

Item	Material
Housing	Stainless steel 300 series
Bushing	Stainless steel 300 series
Plug	Stainless steel 300 series
Adapter seal	FKM
Electrical connector	Contact pins in gold plated brass Housing in plastics (PA) Seal in FKM

Clean-In-Place (CIP)

Withstands cleaning routines up to 194 °F (90 °C)

Steam-In-Place (SIP)

Withstands cleaning routines up to 284 °F (140 °C)

10.13 EU Declaration of Conformity

Figure 10-1: EU Declaration of Conformity

	
EU Declaration of Conformity No: 1408H	
We,	
Rosemount Tank Radar AB Layoutvägen 1 S-435 33 MÖLNLYCKE Sweden	
declare under our sole responsibility that the product,	
Rosemount™ 1408H Level Transmitter	
manufactured by,	
Rosemount Tank Radar AB Layoutvägen 1 S-435 33 MÖLNLYCKE Sweden	
is in conformity with the provisions of the European Community Directives, including the latest amendments, as shown in the attached schedule.	
Presumption of conformity is based on the application of the harmonized standards, normative documents or other documents and, when applicable or required, a European Community notified body certification, as shown in attached schedule.	
 _____ (signature)	Manager Product Approvals _____ (function name - printed)
Dajana Prastalo _____ (name - printed)	2022-05-05 _____ (date of issue)
Page 1 of 2	

**Schedule
No: 1408H**

EMC, Electromagnetic Compatibility Directive (2014/30/EU)

EN 61326-1:2013

RE, Radio Equipment Directive (2014/53/EU)

ETSI EN 302 372:2016; EN 62311:2008

Low Voltage Directive (2014/35/EU)



EN 61010-1:2010 + A1:2019 + AC:2019-04

RoHS Directive (2011/65/EU) Amended 2015/863

IEC 63000:2018

10.14 UKCA Declaration of Conformity

Figure 10-2: UKCA Declaration of Conformity

	
UKCA Declaration of Conformity No: 1408H	
<hr/>	
We,	
Rosemount Tank Radar AB Layoutvägen 1 S-435 33 MÖLNLYCKE Sweden	
declare under our sole responsibility that the product,	
Rosemount™ 1408H Level Transmitter	
manufactured by,	
Rosemount Tank Radar AB Layoutvägen 1 S-435 33 MÖLNLYCKE Sweden	
to which this declaration relates, is in conformity with the relevant statutory requirements of Great Britain, including the latest amendments, as shown in the attached schedule. Assumption of conformity is based on the application of the designated standards and, when applicable or required, a UK Conformity Assessment Body certification, as shown in the attached schedule.	
 _____ (Signature)	Manager Product Approvals _____ (function name – printed)
Dajana Prastalo _____ (name – printed)	2022-05-05 _____ (date of issue)
Page 1 of 2	

UKCA Declaration of Conformity
No: 1408H

Electromagnetic Compatibility Regulations 2016 (S.I. 2016/1091)

EN 61326-1:2013

Radio Equipment Regulations 2017 (S.I. 2017/1206)

ETSI EN 302 372:2016; EN 62311:2008

Electrical Equipment (Safety) Regulations 2016 (S.I. 2016/1101)

EN 61010-1:2010 + A1:2019 + AC:2019-04

The Restriction of the Use of Certain Hazardous Substances in Electrical and Electronic Equipment Regulations 2012 (S.I. 2012/3032)

IEC 63000:2018

10.15 China RoHS

List of Model Parts with China RoHS Concentration above MCVs
含有China RoHS管控物质超过最大浓度限值的部件型号列表

Part Name 部件名称	Hazardous Substances / 有害物质					
	Lead 铅 (Pb)	Mercury 汞 (Hg)	Cadmium 镉 (Cd)	Hexavalent Chromium 六价铬 (Cr +6)	Polybrominated biphenyls 多溴联苯 (PBB)	Polybrominated diphenyl ethers 多溴联苯醚 (PBDE)
Electronics Assembly 电子组件	X	O	O	O	O	O
Housing Assembly 壳体组件	O	O	O	O	O	O

This table is proposed in accordance with the provision of SJ/T11364

本表格系依据SJ/T11364的规定而制作。

O: Indicate that said hazardous substance in all of the homogeneous materials for this part is below the limit requirement of GB/T 26572.

O: 意为该部件的所有均质材料中该有害物质的含量均低于GB/T 26572所规定的限量要求。

X: Indicate that said hazardous substance contained in at least one of the homogeneous materials used for this part is above the limit requirement of GB/T 26572.

X: 意为在该部件所使用的所有均质材料里，至少有一类均质材料中该有害物质的含量高于GB/T 26572所规定的限量要求。



Quick Start Guide
00825-0100-4480, Rev. AD
May 2022

For more information: [Emerson.com](https://www.emerson.com)

©2022 Emerson. All rights reserved.

Emerson Terms and Conditions of Sale are available upon request. The Emerson logo is a trademark and service mark of Emerson Electric Co. Rosemount is a mark of one of the Emerson family of companies. All other marks are the property of their respective owners.

ROSEMOUNT™

