

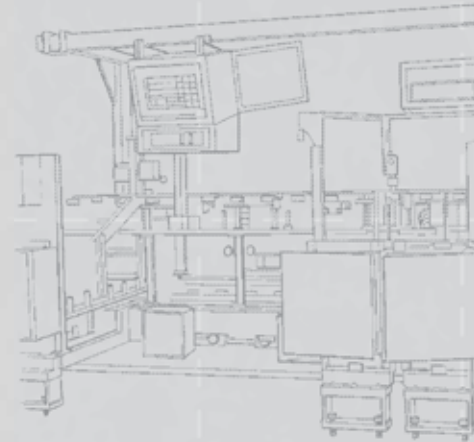

Micromatic

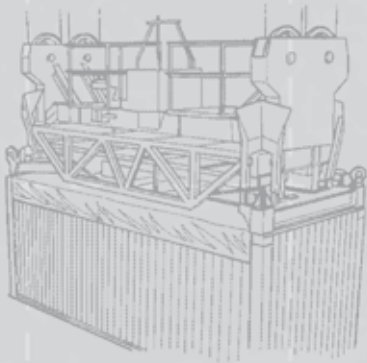
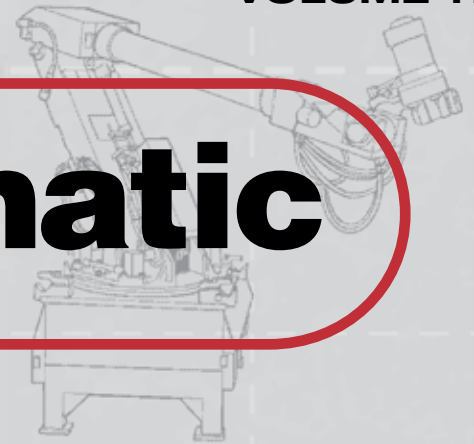

Rotary Actuators

HYDRAULIC AND PNEUMATIC





Micromatic

LOW PRESSURE PNEUMATIC

- 5 Standard Sizes
- 150 PSI
- Up to 570 in/lbs of Torque
- Small - As Light As 10 oz.
- Quick Delivery
- Economical
- Adjustable Stop Control
- Electrical End Position Indicator

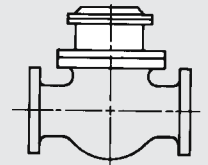
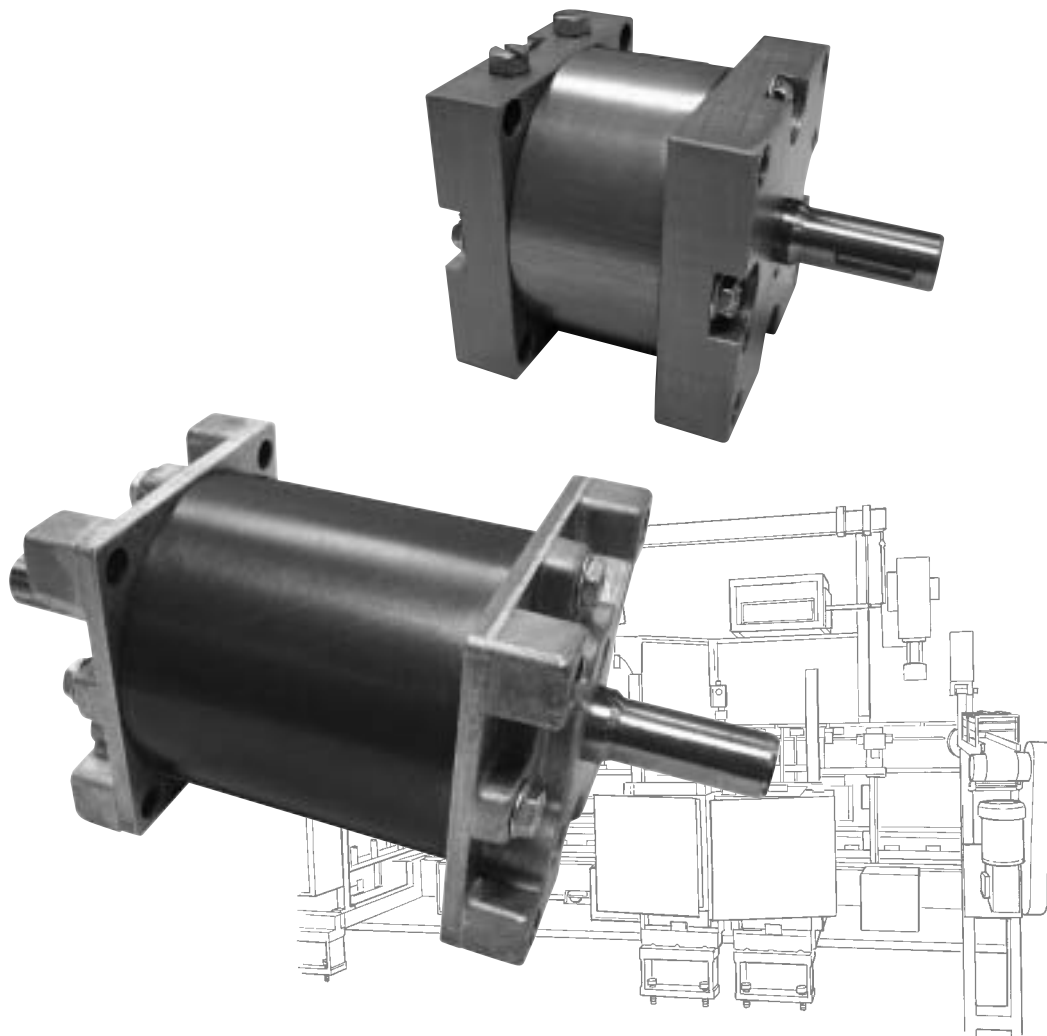

VALVE OPEN—CLOSE

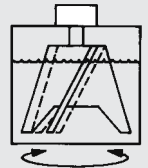

MIX—STIR

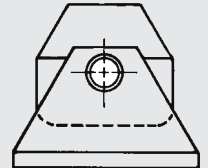

TURNOVER—DUMP

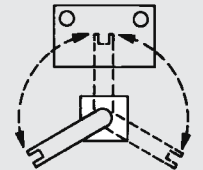

LOAD—POSITION—UNLOAD

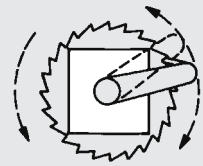

CONTINUOUS ROTATION

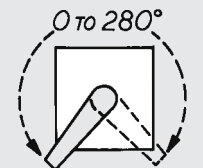

TURN—OSCILLATE

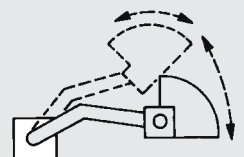

MATERIAL HANDLING

PROVIDING the “MUSCLE” for your lifting, turning, indexing, opening, closing, clamping, mixing, bending, testing, steering. . . **applications.**

PNEUMATIC LP MODELS

**SINGLE AND DOUBLE VANE
LOW PRESSURE 150 PSI MAX.**

LP-11, LP-12, LP-22 & LP-24

NOTE: ALL LP MODEL ACTUATORS ARE DESIGNED TO OPERATE ON DRY, NON-LUBRICATED AIR. CONSULT FACTORY FOR SPECIFIC RECOMMENDATIONS.

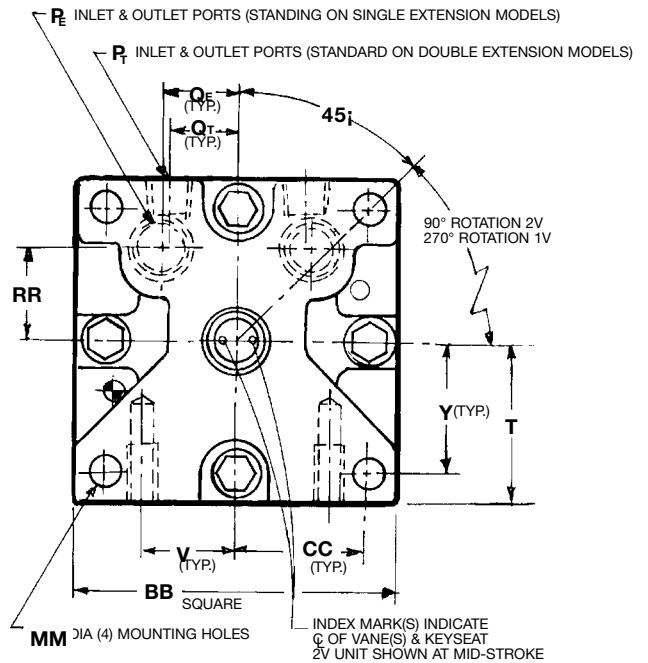
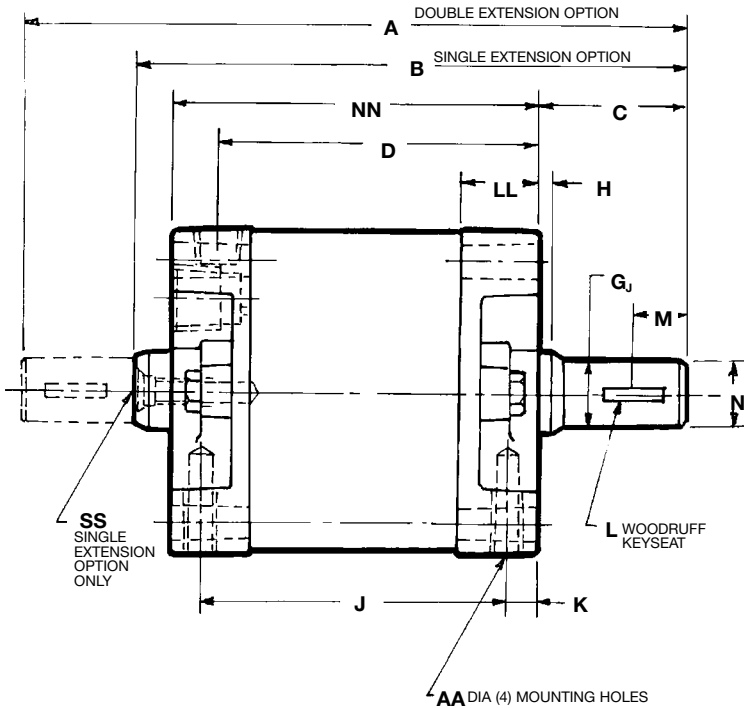

FOR LP-11 & LP-12

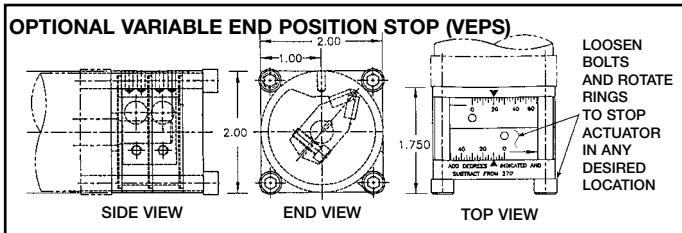

FOR LP-22 & LP-24

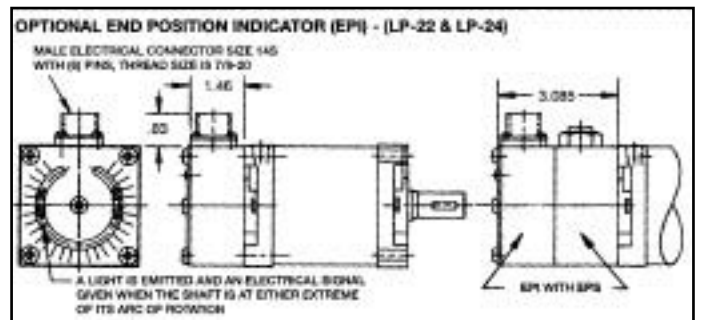
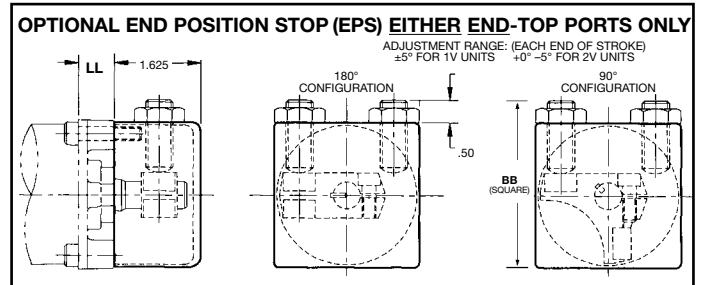

PERFORMANCE

SINGLE VANE 270° ROTATION (±1°)									
MODEL	TORQUE IN-LBS (N•m)					VOLUMETRIC DISP. IN ³ (cm ³)		WEIGHT Lb (Kg)	THRUST LOAD Lb (Kg)
	50 PSI (3.4 BAR)	75 PSI (5.2 BAR)	100 PSI (6.9 BAR)	125 PSI (8.6 BAR)	150 PSI (10.3 BAR)	Per 270°	Per RAD		
	LP-11	4 (.45)	7 (.79)	11 (1.24)	14 (1.58)	17 (1.92)	.839 (13.75)	.178 (2.92)	.58 (.26)
LP-12	10 (1.13)	16 (1.81)	23 (2.60)	29 (3.28)	36 (4.07)	1.68 (27.54)	.356 (5.83)	.75 (.34)	8 (3.63)
LP-22	25 (2.83)	41 (4.63)	57 (6.44)	73 (8.25)	89 (10.06)	3.86 (63.27)	.819 (13.42)	2.1 (.96)	12 (5.44)
LP-24	51 (5.76)	84 (9.49)	116 (13.11)	148 (16.72)	180 (20.34)	7.68 (125.9)	1.63 (26.72)	3.1 (1.41)	12 (5.44)

DOUBLE VANE 90° ROTATION (±1°)									
MODEL	TORQUE IN-LBS (N•m)					VOLUMETRIC DISP. IN ³ (cm ³)		WEIGHT Lb (Kg)	THRUST LOAD Lb (Kg)
	50 PSI (3.4 BAR)	75 PSI (5.2 BAR)	100 PSI (6.9 BAR)	125 PSI (8.6 BAR)	150 PSI (10.3 BAR)	Per 90°	Per RAD		
	LP-11	11 (1.24)	19 (2.15)	26 (2.94)	34 (3.84)	42 (4.75)	.559 (9.16)	.356 (5.83)	.62 (.28)
LP-12	26 (2.94)	43 (4.86)	59 (6.67)	75 (8.48)	92 (10.40)	1.12 (18.36)	.713 (11.69)	.81 (.37)	8 (3.63)
LP-22	58 (6.55)	94 (10.62)	130 (14.69)	166 (18.76)	202 (22.83)	2.56 (41.96)	1.63 (26.72)	2.2 (1.00)	12 (5.44)
LP-24	129 (14.58)	209 (23.62)	289 (32.66)	370 (41.81)	450 (50.85)	5.14 (84.24)	3.27 (53.60)	3.3 (1.51)	12 (5.44)

APPLICATION DATA DIMENSIONS IN INCHES (METRIC)

	LP-11	LP-12	LP-22	LP-24
A	4.00 (101.60)	5.00 (127.00)	6.32 (160.53)	8.32 (211.33)
B	3.18 (80.77)	4.18 (106.17)	5.25 (133.35)	7.25 (184.15)
C	1.00 (25.40)	1.00 (25.40)	1.41 (35.81)	1.41 (35.81)
D	1.75 (44.45)	2.75 (69.85)	3.06 (77.72)	5.06 (128.52)
G_J	.44 DIA. (11.18)	.44 DIA. (11.18)	.75 DIA. (19.05)	.75 DIA. (19.05)
H	.09 (2.29)	.09 (2.29)	.12 (3.05)	.12 (3.05)
J	1.63 (41.40)	2.63 (66.80)	2.63 (66.80)	4.63 (117.60)
K	.19 (4.80)	.19 (4.80)	.44 (11.18)	.44 (11.18)
L	1/16x1/2 #204 (1.59x12.70)	1/16x1/2 #204 (1.59x12.70)	1/8x5/8 #405 (3.18x15.88)	1/8x5/8 #405 (3.18x15.88)
M	.38 (9.65)	.38 (9.65)	.50 (12.70)	.50 (12.70)
N*	.3735 DIA. (9.487)	.3735 DIA. (9.487)	.6235 DIA. (15.837)	.6235 DIA. (15.837)
P_E	1/8-27 NPTF	1/8-27 NPTF	1/8-27 NPTF	1/8-27 NPTF
P_T	#10-32	#10-32	1/8-27 NPTF	1/8-27 NPTF
Q_E	.48 (12.19)	.48 (12.19)	.65 (16.51)	.65 (16.51)
Q_T	.44 (11.17)	.44 (11.17)	.65 (16.51)	.65 (16.51)
T**	1.030 (26.16)	1.030 (26.16)	1.530 (38.86)	1.530 (38.86)
V	.60 (15.24)	.60 (15.24)	.88 (22.35)	.88 (22.35)
Y	.84 (21.34)	.84 (21.34)	1.25 (31.75)	1.25 (31.75)
AA	#10-24 .38DP	#10-24 .38DP	1/4-20 .50DP	1/4-20 .50DP
BB	2.06 (52.32)	2.06 (52.32)	3.06 (77.72)	3.06 (77.72)
CC	.84 (21.34)	.84 (21.34)	1.25 (31.75)	1.25 (31.75)
LL	.50 (12.70)	.50 (12.70)	.75 (19.05)	.75 (19.05)
MM	.21 (5.33)	.21 (5.33)	.27 (6.86)	.27 (6.86)
NN	2.00 (50.80)	3.00 (76.20)	3.50 (88.90)	5.50 (139.70)
RR	.60 (15.24)	.60 (15.24)	.85 (21.59)	.85 (21.59)
SS	#10-24UNC-2B TAP .50 DEEP (12.70)	#10-24UNC-2B TAP .50 DEEP (12.70)	#1/4-20UNC-2B TAP .62 DEEP (15.75)	#1/4-20UNC-2B TAP .62 DEEP (15.75)

TEST PARAMETERS — AIR			
MODEL	MAX BREAK PSI (BAR)	BY-PASS LEAKAGE-MAX ALLOWABLE	
		CUBIC FT. PER MIN. AT 100 PSI (6.9 BAR)	CUBIC CM. PER MIN. AT 100 PSI (6.9 BAR)
LP-11-1V	15 (1.03)	.20	5665
LP-11-2V	12 (.83)	.25	7080
LP-12-1V	12 (.83)	.20	5665
LP-12-2V	10 (.69)	.25	7080
LP-22-1V	10 (.69)	.20	5665
LP-22-2V	10 (.69)	.25	7080
LP-24-1V	10 (.69)	.20	5665
LP-24-2V	10 (.69)	.25	7080

IMPORTANT NOTES:

- External stops should be used to limit angular travel as the actuator abutments (shoes) are not designed as mechanical stops.
- Consult factory for applications requiring low breakaway and maximum torque output.

*± .0005 IN. (0.01 MM) **± .005 IN. (0.13 MM)

LP-11, LP-12, LP-22 & LP-24

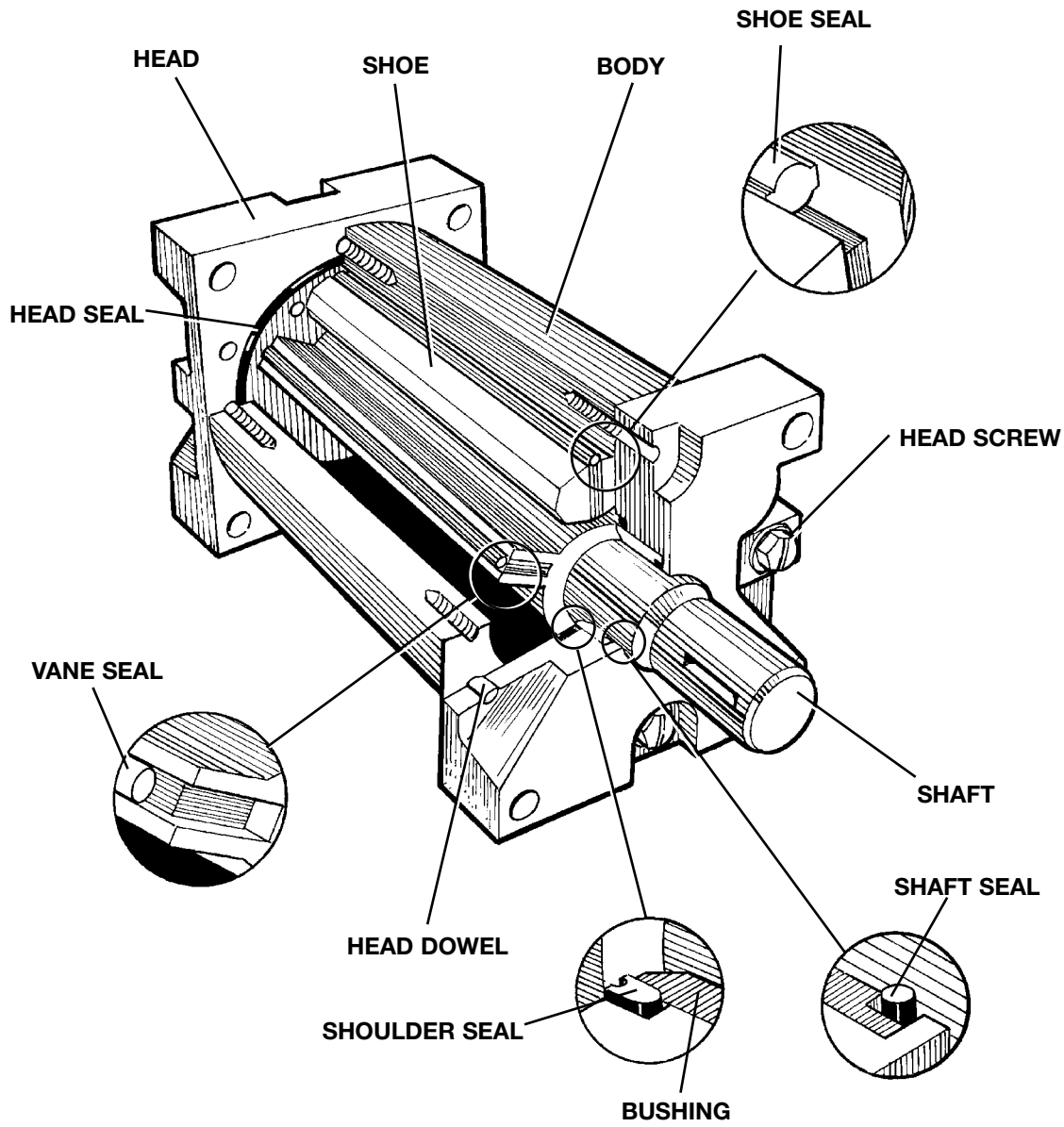

HOW TO ORDER

Sample: LP 22 2V DE TP

Model _____

Size _____

Number of Vanes _____
 1V—Single Vane
 2V—Double Vane

Shaft Extension _____
 SE—Single Extension
 DE—Double Extension

Port Options _____
 TP—Top Ports
 EP—End Ports

OPTIONS

EPS2 EPI2

EPI ELECTRICAL POSITION INDICATOR*			
	SWITCH TYPE	FUNCTION	SWITCHING VOLTAGE
1	REED SWITCH	SPST NORMALLY OPEN	5-120 VDC/VAC 50/60 HZ
2	HALL EFFECT SOURCING	NORMALLY OPEN PNP OUTPUT	6-24 VDC
3	HALL EFFECT SINKING	NORMALLY OPEN NPN OUTPUT	6-24 VDC

*For LP-22, LP-24 only at this time

VERS (For LP-11 and LP-12 only)
 EPS1/180° (LP-22 and LP-24 only)
 EPS2/90° (LP-22 and LP-24 only)

In order that your actuator order be processed promptly, please furnish complete information as shown by example. For special seal compounds or other special features, please consult Micromatic.



Micromatic

MEDIUM PRESSURE

11 Standard Sizes

1,000 PSI

Up to 216,730 in/lbs of Torque

Higher Pressures Available

As Light As 4 oz.

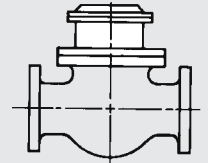
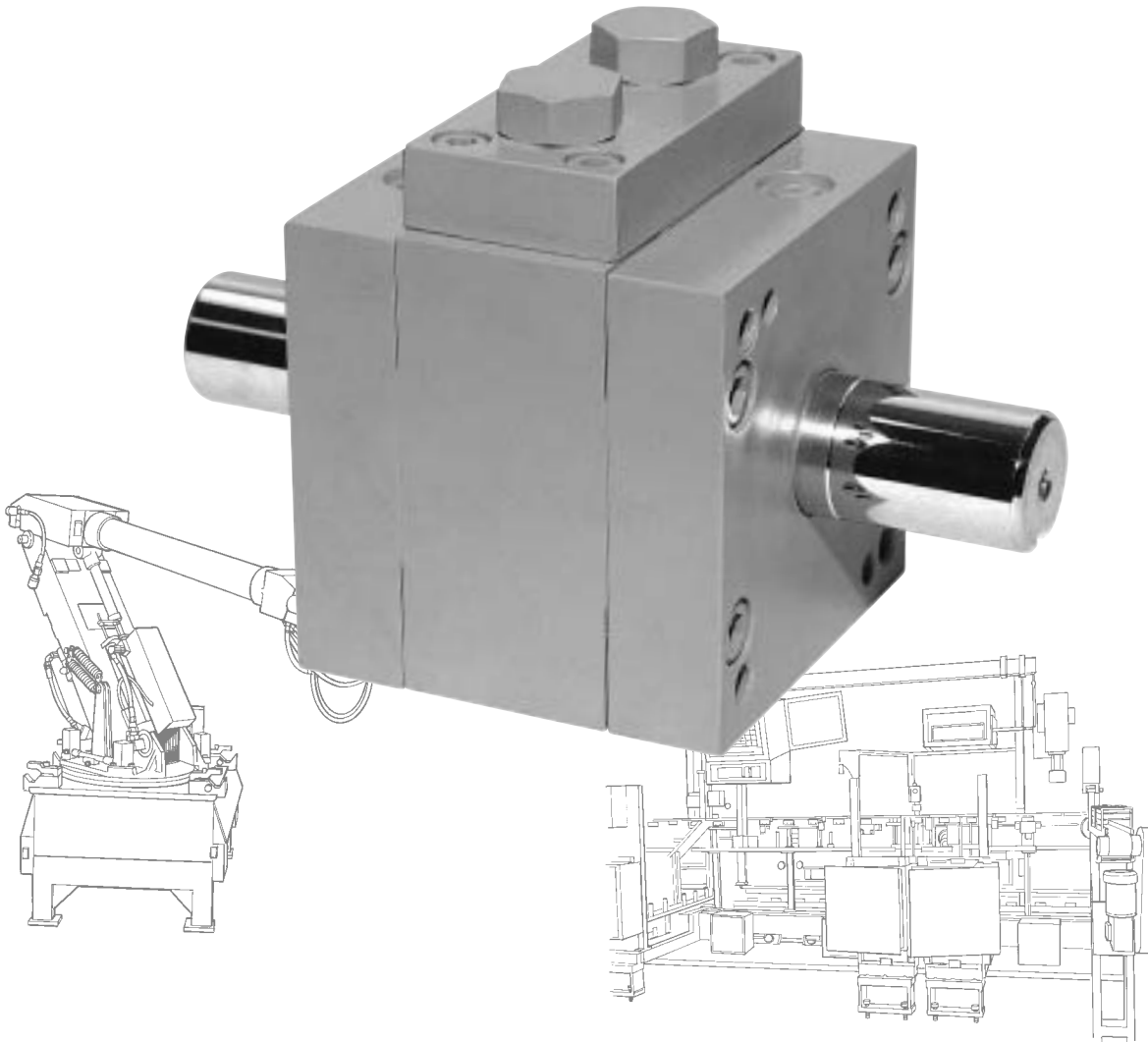

VALVE OPEN—CLOSE

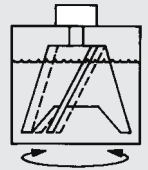

MIX—STIR

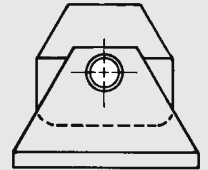

TURNOVER—DUMP

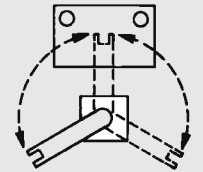

LOAD—POSITION—UNLOAD

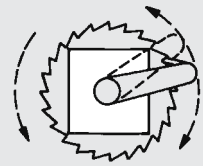

CONTINUOUS ROTATION



TURN—OSCILLATE

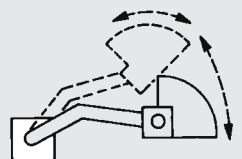

MATERIAL HANDLING

PROVIDING the “MUSCLE” for your lifting, turning, indexing, opening, closing, clamping, mixing, bending, testing, steering... **applications.**

MP MODELS

**MEDIUM PRESSURE
1000 P.S.I. STD.**

**(For Higher Operating Pressures
or High Water Base Configurations
Contact Plant)**

MINI MPR-1x.4 & MPR-1x1 Medium Pressure 750 PSI Max.

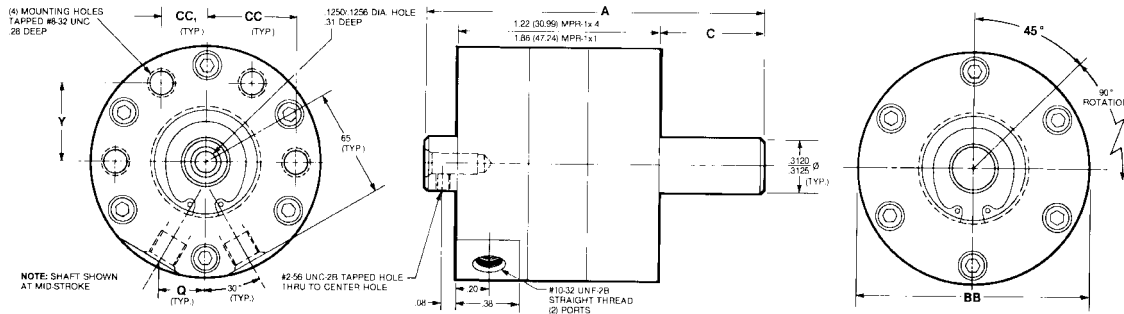

MPJ-11 & MPJ-22

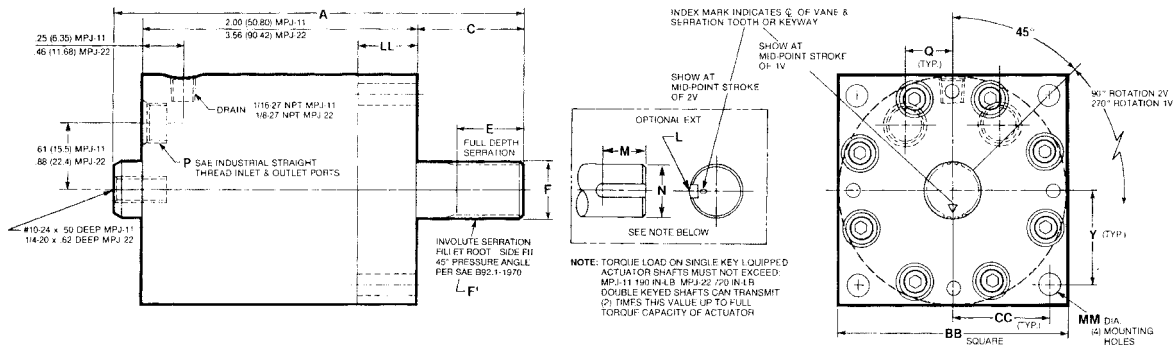

MP-32 THRU MP-128

END BASE MOUNTING

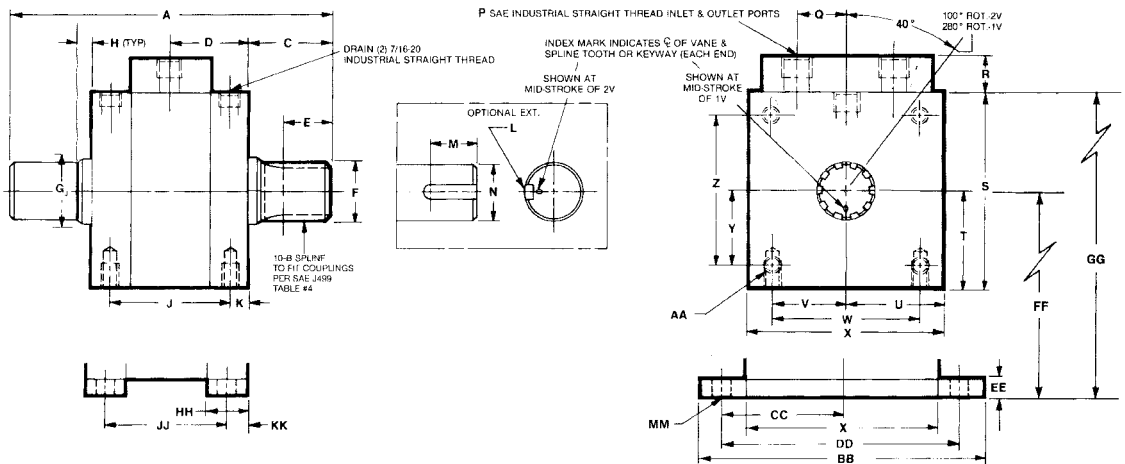

FOOT MOUNTING



FLANGE MOUNTING

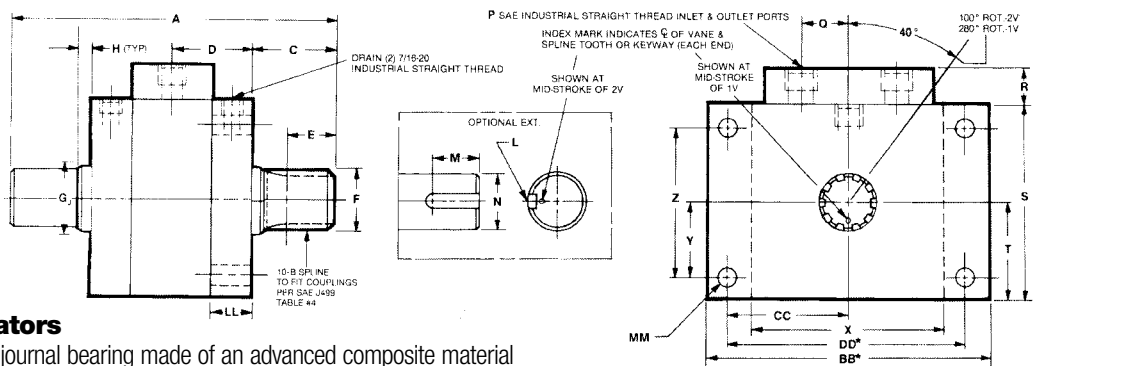

Journal Bearing Actuators

Standard MP actuators utilize a journal bearing made of an advanced composite material that is filament wound and PTFE lined. Additional precision engineered components include high performance seals for shaft, shoulder, vane and shoe.

*NOTE: ON MPJ-116 & MPJ-128 USE END MOUNT DIMENSIONS

NOTES: Connection of drains will add significant life to shaft seals. This is highly recommended. See cut away view on page 9, page 27 for optional porting, pages 30 and 31 for optional manifolds and shaft couplings.

APPLICATION DATA

DIMENSIONS IN INCHES (METRIC)

	MPR-1x.4	MPR-1x1	MPJ-11	MPJ-22	MPJ-32	MPJ-34	MPJ-63	MPJ-84	MPJ-105	MPJ-116	MPJ-128
A	2.03 (51.6)	2.67 (67.8)	3.18 (81)	5.25 (133.4)	8.25 (210)	10.25 (260)	13.88 (352)	16.88 (429)	18.88 (480)	22.38 (568)	25.38 (645)
C	.63 (16)	.63 (16)	1.00 (25.40)	1.42 (36)	2.05 (52)	2.05 (52)	3.49 (88.6)	4.49 (114)	4.49 (114)	5.02 (127.5)	5.50 (140)
D	—	—	—	—	2.08 (52.8)	3.08 (78)	3.45 (87.6)	3.95 (100.3)	4.95 (125.7)	6.17 (156.7)	7.19 (182.6)
E	—	—	.54 (13.7)	.90 (22.9)	1.12 (28.5)	1.12 (28.5)	1.75 (44.5)	2.50 (63.5)	2.75 (69.8)	3.25 (82.6)	4.00 (101.6)
F*	—	—	.4997 (12.692)	.7497 (19.042)	1.2455 (31.636)	1.2455 (31.636)	1.9935 (50.635)	2.4935 (63.335)	2.9935 (76.035)	3.4935 (88.735)	3.9935 (101.435)
F¹	—	—	19T 40/80P .4750PD	29T 40/80P .7250PD	—	—	—	—	—	—	—
G	—	—	—	—	1.27 (32.26)	1.27 (32.26)	2.02 (51.3)	3.00 (76.2)	3.02 (76.7)	3.74 (95)	—
H	—	—	—	—	.30 (7.6)	.30 (7.6)	.49 (12)	.49 (12)	.49 (12)	.50 (12)	.09 (2.3)
J	—	—	—	—	3.25 (82.5)	5.25 (133.4)	5.50 (139.7)	6.00 (152.4)	7.00 (177.8)	9.50 (241.3)	11.25 (285.75)
K	—	—	—	—	.45 (11.4)	.45 (11.4)	.70 (17.8)	.95 (24)	1.45 (36.8)	1.44 (36.6)	1.56 (39.6)
L	—	—	1/8 x 1/16 (3 x 1.6)	3/16 x 3/32 (4.8 x 2.4)	3/16 x 3/32 (4.8 x 2.4)	3/16 x 3/32 (4.8 x 2.4)	1/2 x 1/4 (12.7 x 6.4)	5/8 x 1/16 (15.9 x 7.9)	3/4 x 3/8 (19 x 19.5)	1 x 1/2 (25.4 x 12.7)	1 x 1/2 (25.4 x 12.7)
M	—	—	.60 (15.2)	1.00 (25.4)	1.00 (25.4)	1.00 (25.5)	1.75 (44.5)	2.50 (63.5)	2.75 (69.8)	3.75 (95.25)	4.00 (101.6)
N*	—	—	.4985 (12.662)	.7485 (19.012)	1.2485 (31.712)	1.2485 (31.712)	1.9985 (50.762)	2.4985 (63.462)	2.9985 (76.162)	3.4985 (88.862)	3.9985 (101.562)
P	—	—	3/8-24 SAE	1/2-20 SAE	7/8-14	7/8-14	1 1/8-12	1 1/8-12	1 3/8-12	1 7/8-12	1 7/8-12
Q	.26 (6.60)	.26 (6.60)	.42 (10.67)	.65 (16.51)	.94 (24)	.94 (24)	1.25 (31.75)	1.63 (41.4)	2.00 (50.8)	2.50 (63.5)	2.50 (63.5)
R	—	—	—	—	.75 (19)	.75 (19)	1.88 (47.8)	1.00 (25.4)	1.00 (25.4)	1.25 (31.75)	1.25 (31.75)
S	—	—	—	—	4.25 (108)	4.25 (108)	8.00 (203)	10.50 (267)	12.50 (317.5)	14.25 (362)	16.00 (406.4)
T**	—	—	—	—	2.125 (53.98)	2.125 (53.98)	4.00 (101.6)	5.25 (133.35)	6.25 (158.75)	7.125 (180.98)	8.00 (203.2)
U	—	—	—	—	2.12 (53.85)	2.12 (53.85)	4.00 (101.6)	5.25 (133.4)	6.25 (158.75)	7.12 (180.8)	8.00 (203.2)
V	—	—	—	—	1.63 (41.4)	1.63 (41.4)	3.00 (76.2)	4.25 (108)	5.00 (127)	6.00 (152.4)	6.75 (171.5)
W	—	—	—	—	3.25 (82.55)	3.25 (82.55)	6.00 (152.4)	8.50 (216)	10.00 (254)	12.00 (304.8)	13.50 (343)
X	—	—	—	—	4.25 (108)	4.25 (108)	8.00 (203)	10.50 (267)	12.50 (317.5)	14.25 (362)	16.00 (406.4)
Y	.470 (11.93)	.470 (11.93)	.84 (21.34)	1.25 (31.75)	1.63 (41.4)	1.63 (41.4)	3.00 (76.2)	4.25 (108)	5.00 (127)	6.00 (152.4)	6.75 (171.5)
Z	—	—	—	—	3.25 (82.55)	3.25 (82.55)	6.00 (152.4)	8.50 (216)	10.00 (254)	12.00 (304.8)	13.50 (343)
AA	—	—	—	—	3/8-16 .56 DP	3/8-16 .56 DP	1/2-10 1.12 DP	3/4-10 1.12 DP	1-8 1.75 DP	1-8 1.75 DP	1 1/4-7 2.00 DP
BB	1.38 (35.05)	1.38 (35.05)	2" SQ. (50.8 SQ.)	3" SQ. (76.2 SQ.)	6.25 (159)	6.25 (159)	11.00 (279)	13.50 (343)	16.50 (419)	18.25 (464)	20.50 (521)
CC	.543 (13.79)	.543 (13.79)	.84 (21.34)	1.25 (31.75)	2.63 (66.8)	2.63 (66.8)	4.75 (120.7)	6.00 (152.4)	7.25 (184.15)	8.12 (206.2)	9.12 (231.6)
CC¹	.271 (6.88)	.271 (6.88)	—	—	—	—	—	—	—	—	—
DD	—	—	—	—	5.25 (133.4)	5.25 (133.4)	9.50 (241.3)	12.00 (304.8)	14.50 (368.3)	16.25 (412.75)	18.25 (463.6)
EE	—	—	—	—	.38 (10)	.38 (10)	1.00 (25.4)	1.50 (38)	1.75 (44.5)	1.75 (44.5)	2.00 (51)
FF**	—	—	—	—	2.50 (63.5)	2.50 (63.5)	5.00 (127)	6.75 (171.45)	8.00 (203.2)	8.75 (225.43)	10.00 (254)
GG	—	—	—	—	4.63 (117.6)	4.63 (117.6)	9.00 (229)	12.00 (305)	14.25 (362)	16.00 (406.4)	18.00 (457)
HH	—	—	—	—	1.12 (28.5)	1.12 (28.5)	2.00 (50.8)	2.00 (51)	2.50 (64)	3.00 (76)	3.00 (76)
JJ	—	—	—	—	3.06 (77.7)	5.06 (128.5)	5.00 (127)	6.00 (152.4)	7.50 (190.5)	9.50 (241.3)	11.25 (285.75)
KK	—	—	—	—	.55 (14)	.55 (14)	.95 (24)	.95 (24)	1.20 (30.5)	1.44 (36.6)	1.56 (40)
LL	—	—	.50 (12.70)	.74 (18.80)	1.08 (27.4)	1.08 (27.4)	1.95 (49.5)	1.95 (49.5)	2.45 (62)	2.91 (73.9)	3.19 (81)
MM	—	—	.22 (5.59)	.28 (7.11)	.41 (10.4)	.41 (10.4)	.78 (19.8)	.78 (19.8)	1.03 (26.2)	1.03 (26.2)	1.32 (33.5)

NOTES:

*PER 270° MP-11 & MP-22

**PER 90°, MPR-1x.4, MPR-1x1, MP-11 & MP-22

750 PSI MAX. MPR-1x.4 & MPR-1x1

*±.0005 in. (0.01 mm) **±.005 in. (0.13 mm)

NOTE: See how to order on page 9

PERFORMANCE

SINGLE VANE 280° ROTATION (±5°) *						
MODEL	TORQUE IN-LBS (N•m)			VOLUMETRIC DISPLACEMENT **IN ³ (cm ³)		APPROX. WEIGHT LB (kg)
	100 PSI (6.9 BAR)	500 PSI (34.5 BAR)	1000 PSI (69.0 BAR)	PER 280°	PER RAD	
	MPJ-11	8 (.90)	56 (6.33)	117 (13.22)	.835 (13.69)	
MPJ-22	56 (6.33)	333 (37.63)	679 (76.73)	3.82 (62.61)	.815 (13.36)	3 (1.36)
MPJ-32	103 (11.64)	705 (79.67)	1595 (180.24)	9.2 (150.79)	1.88 (30.81)	19 (8.6)
MPJ-34	206 (23.28)	1410 (159.33)	3190 (360.47)	18.4 (301.58)	3.76 (61.31)	26 (11.8)
MPJ-63	600 (67.80)	4090 (462.17)	9280 (1048.64)	53.30 (873.59)	10.90 (179)	122 (55.2)
MPJ-84	1430 (161.59)	9750 (1101.75)	22100 (2497.30)	127.40 (2088.09)	26.07 (428)	203 (92.1)
MPJ-105	2850 (322.05)	19400 (2192.20)	44000 (4972)	253.3 (4151.59)	51.83 (850)	348 (157.9)
MPJ-116	4650 (525.45)	31700 (3582)	71800 (8113)	412.9 (6767.43)	84.50 (1386)	552 (250.4)
MPJ-128	6625 (748.63)	45151 (5102)	102345 (11565)	588.4 (9643.88)	120.41 (1975)	835 (378.8)

FOR 1500 PSI (103.4 BAR) CONTACT PLANT.

DOUBLE VANE 100° ROTATION (±5°) **						
MODEL	TORQUE IN-LBS (N•m)			VOLUMETRIC DISPLACEMENT **IN ³ (cm ³)		APPROX. WEIGHT LB (kg)
	100 PSI (6.9 BAR)	500 PSI (34.5 BAR)	1000 PSI (69.0 BAR)	PER 100°	PER RAD	
	MPR-1x.4	2 (.23)	20 (2.26)	31 (3.50)	.093 (1.52)	
MPR-1x1	5 (.57)	54 (6.10)	85 (9.60)	.258 (4.23)	.164 (2.69)	.32 (.14)
MPJ-11	23 (2.60)	156 (17.63)	322 (36.39)	.557 (9.13)	.357 (5.85)	.84 (.38)
MPJ-22	121 (13.67)	728 (82.26)	1487 (168.03)	2.56 (41.96)	1.63 (26.72)	3.2 (1.45)
MPJ-32	225 (25.43)	1540 (174)	3380 (381.94)	6.60 (108.17)	3.78 (62)	20 (9.1)
MPJ-34	450 (50.85)	3080 (348.04)	6750 (762.75)	13.00 (213.07)	7.44 (122)	27 (12.2)
MPJ-63	1310 (148.03)	8950 (1011.35)	19600 (2214.80)	38.0 (622.82)	21.77 (357)	126 (57.2)
MPJ-84	3120 (352.56)	21350 (2412.55)	46700 (5277.00)	91.0 (1491.49)	52.14 (855)	212 (96.2)
MPJ-105	6220 (702.86)	42500 (4802.50)	93300 (10542.90)	181.0 (2966.59)	103.7 (1700)	364 (165.1)
MPJ-116	10100 (1141.30)	69300 (7831)	152100 (17187)	295.0 (4835.05)	169.0 (2772)	581 (263.5)
MPJ-128	14450 (1633)	98735 (11157)	216730 (24490)	420.3 (6888.72)	240.8 (3950)	875 (396.9)

FOR 1500 PSI (103.4 BAR) CONTACT PLANT.

TEST PARAMETERS — OIL			
MODEL	MAX BREAK IN PSI (BAR) OIL	BY-PASS LEAKAGE MAX ALLOWABLE	
		CUBIC IN. PER MIN. AT 1000 PSI (69.0 BAR) OIL	
		1V	2V
MPR-1x.4	50 (3.4)	—	3.5
MPR-1x1	50 (3.4)	—	3.5
MPJ-11	60 (4.14)	9	9
MPJ-22	60 (4.14)	11	11
MPJ-32	50 (3.45)	12	12
MPJ-34	50 (3.45)	12	12
MPJ-63	50 (3.45)	13	13
MPJ-84	40 (2.8)	14	14
MPJ-105	40 (2.8)	15	15
MPJ-116	40 (2.8)	16	16
MPJ-128	40 (2.8)	17	17

WHEN REFERENCING SHADED AREAS SEE
NOTES ON BOTTOM OF THIS PAGE.

MPR-1 x .4
FOR SERVICE DETAILS CONSULT FACTORY

MPR-1 x 1
FOR SERVICE DETAILS CONSULT FACTORY

MPJ-11
FOR SERVICE DETAILS CONSULT FACTORY

MPJ-22
FOR SERVICE DETAILS CONSULT FACTORY

MPJ

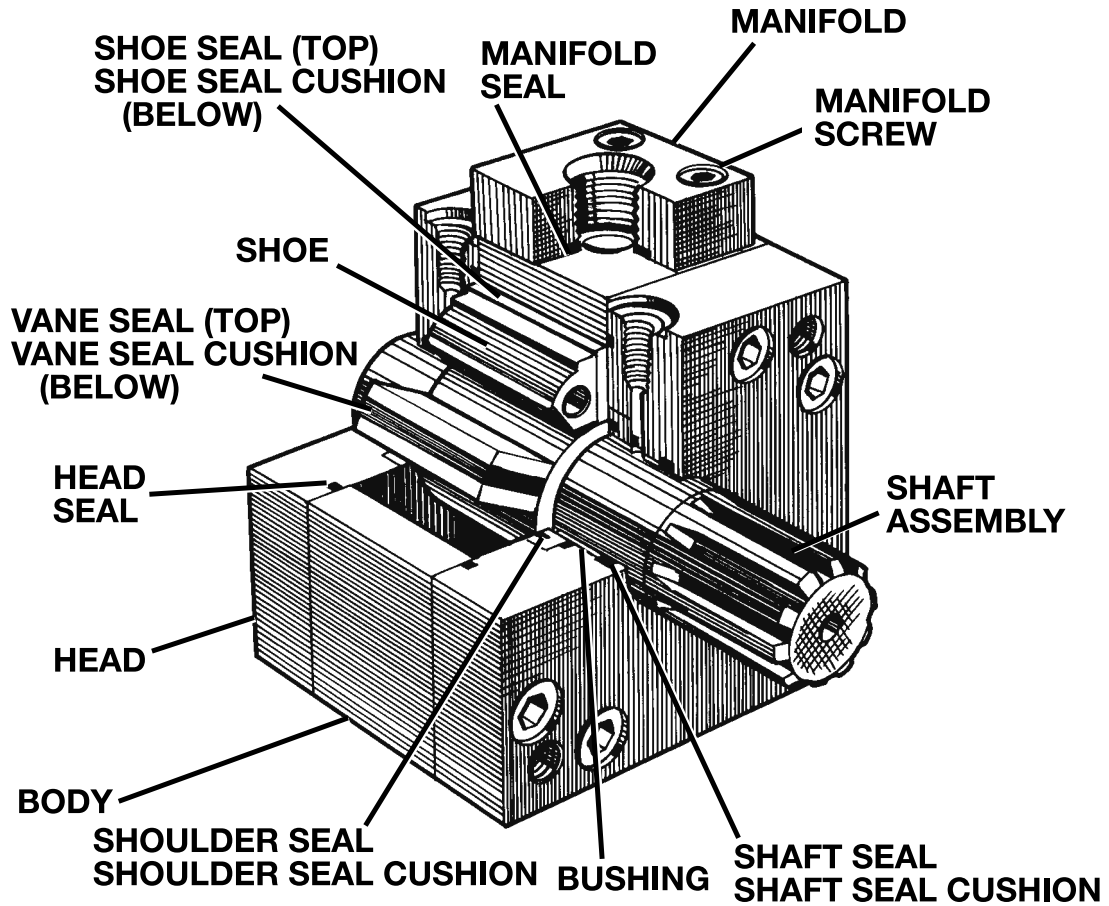

HOW TO ORDER

Sample: MPJ 128 2V DE K BASE OIL

Model _____	Fluid Medium
MPJ _____	Oil, Air,
Size _____	Other _____
Number of Vanes _____	Mounting
1V—Single Vane	End-Base, Foot,
2V—Double Vane	Flange, Special
Shaft Extension _____	Shaft Type
SE—Single Extension	SS—10-B Spline
DE—Double Extension	ISER—45° Involute Serration
	(MPJ-11 & MPJ-22 only)
	K—Keyed
	Z—Special

If you require a special shaft extension, special mounting, air bleeds, special rotation control, or other special requirements, please enclose a drawing showing these requirements.



Micromatic

HIGH PRESSURE

7 Standard Sizes

3,000 PSI

Up to 696,000 in/lbs of Torque

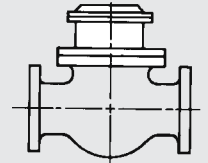
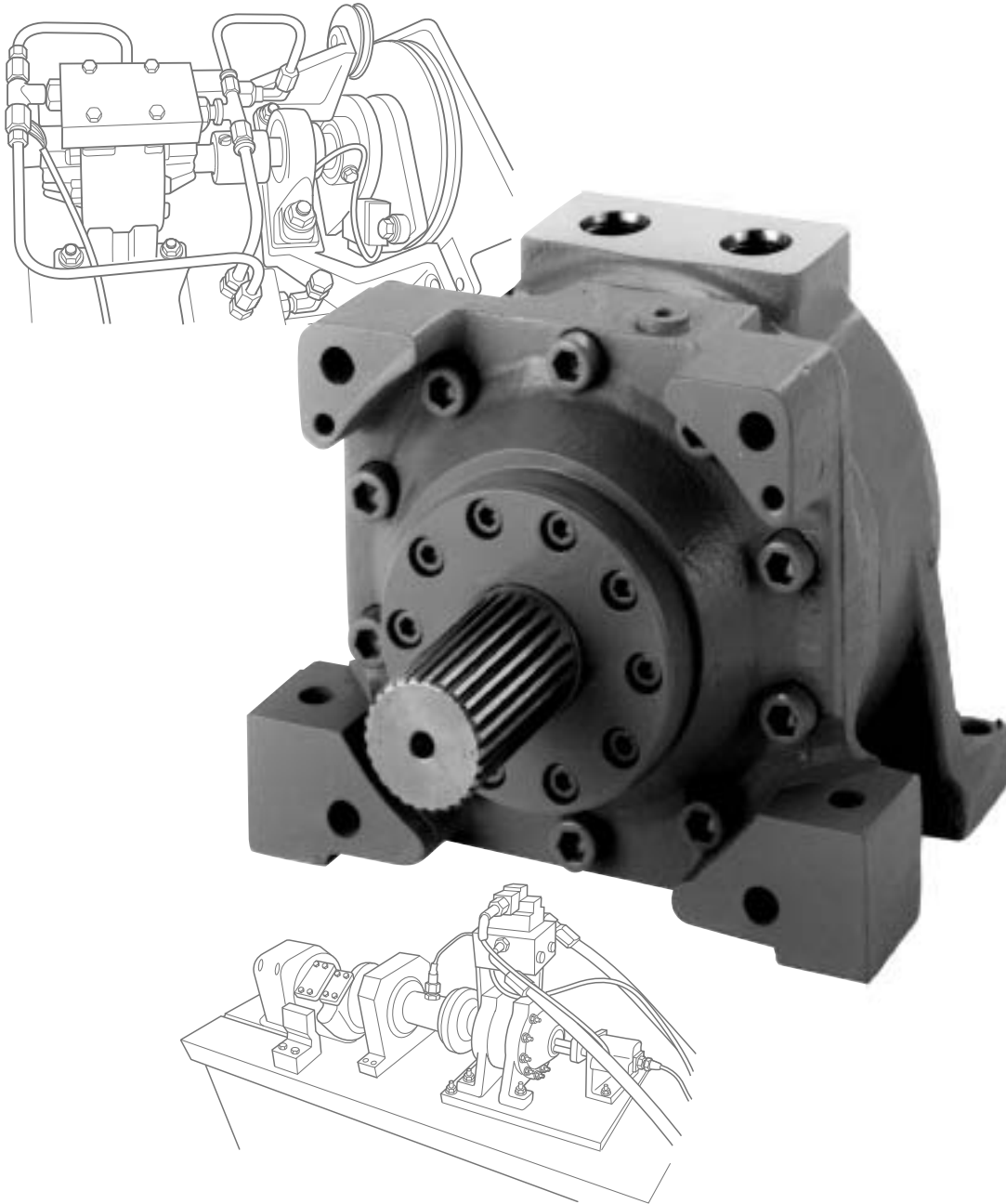

VALVE OPEN—CLOSE

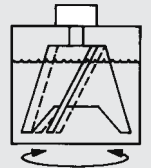

MIX—STIR

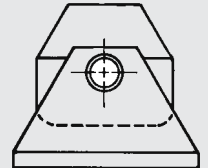

TURNOVER—DUMP

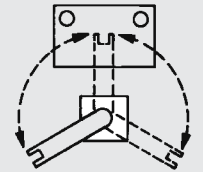

LOAD—POSITION—UNLOAD

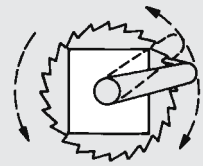

CONTINUOUS ROTATION



TURN—OSCILLATE

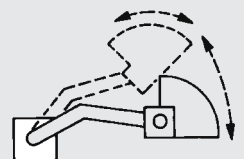

MATERIAL HANDLING

PROVIDING the “**MUSCLE**” for your lifting, turning, indexing, opening, closing, clamping, mixing, bending, testing, steering. . . **applications.**

26R MODELS

**HIGH PRESSURE *1
3000 PSI MAX**

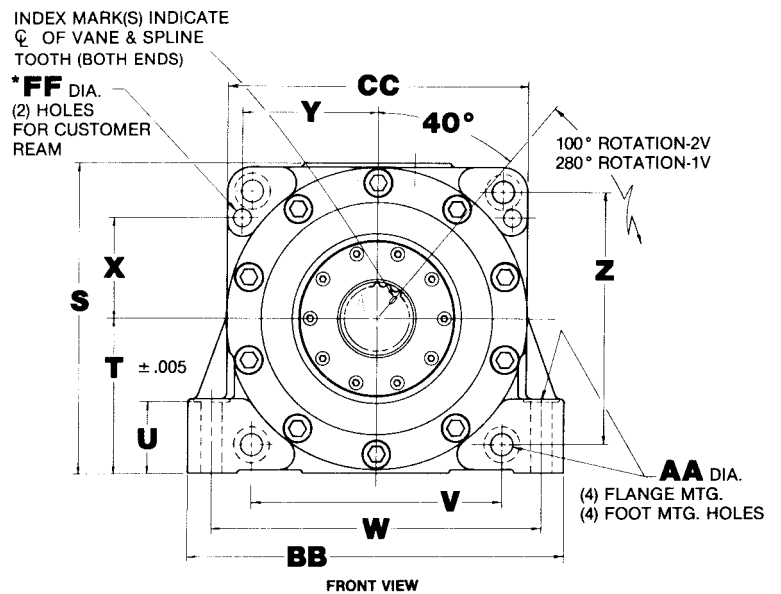
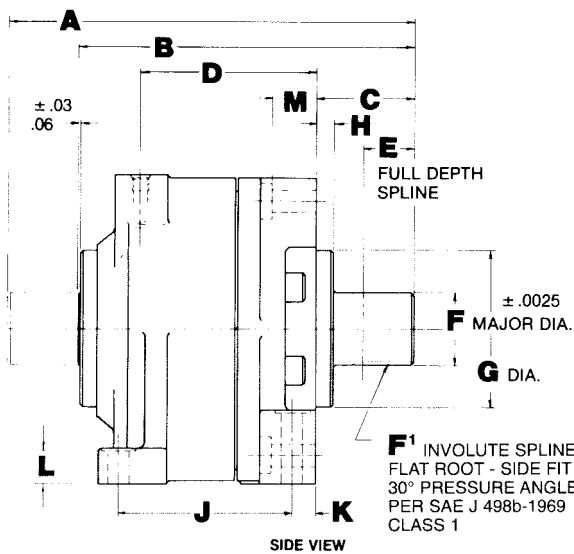
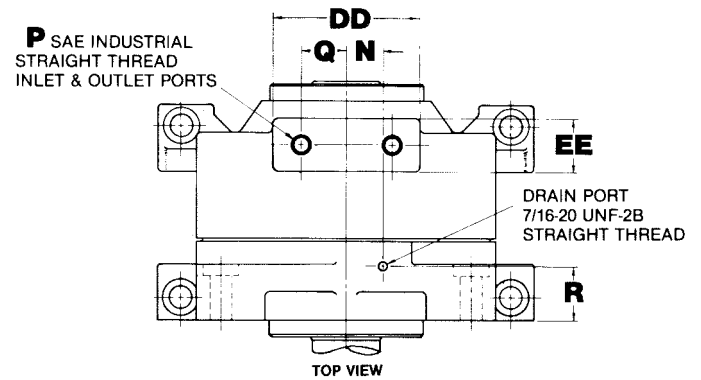

NOTE: Connection of drains will add significant life to shaft seals. *Their use is highly recommended.*

***NOTE:** FOR FLANGE MTD. UNITS THESE HOLES SHOULD BE TRANSFER DRILLED AND REAMED AT INSTALLATION FOR INSERTION OF DOWEL PINS. (THIS WILL AID IN PREVENTING "RACKING" OF ACTUATOR ON MOUNTING BOLTS DUE TO TORSIONAL FORCES)

***1** 2000 PSI maximum is recommended for severe duty applications, such as operating at maximum torque at high cycle rates for extended periods. Please consult factory for applications beyond 2000 PSI. 3000 PSI can be used on intermittent shockless actuations.

NOTE: See cut away view on page 13.

NOTE: See pages 30 and 31 for optional manifolds and shaft couplings.

APPLICATION DATA DIMENSIONS IN INCHES (METRIC)

	26R-2	26R-5	26R-10	26R-17	26R-31	26R-62	26R-124
A	10.08 (256)	12.06 (306.3)	14.19 (360.4)	16.57 (420.9)	18.58 (471.9)	24.38 (619.3)	31.22 (792.9)
B	8.02 (203.7)	9.84 (249.9)	11.50 (292.1)	13.51 (343.2)	15.01 (381.3)	19.44 (493.8)	25.06 (636.5)
C	2.62 (66.5)	2.86 (72.6)	3.41 (86.6)	3.87 (98.3)	4.38 (111.3)	6.02 (152.9)	7.51 (190.8)
D	3.50 (88.9)	4.86 (123.4)	5.63 (143)	6.61 (167.9)	7.80 (198.1)	9.87 (250.7)	12.80 (325.1)
E	1.62 (41.1)	1.75 (44.4)	2.12 (53.8)	2.50 (63.5)	3.00 (76.2)	4.25 (107.9)	5.25 (133.4)
F*	1.3335 (33.871)	1.6685 (42.380)	2.2268 (56.561)	2.6735 (67.907)	3.2735 (83.147)	4.0935 (103.975)	4.8435 (123.025)
F'	26T (20/40P)	26T (16/32P)	26T (12/24P)	26T (10/20P)	32T (10/20P)	32T (8/16P)	38T (8/16P)
G	1.3000PD	1.6250PD	2.1667PD	2.6000PD	3.2000PD	4.0000PD	4.7500PD
H	3.38 (85.9)	4.25 (108)	5.00 (127)	6.00 (152.4)	7.00 (177.8)	9.13 (231.9)	10.50 (266.7)
J	.50 (12.7)	.57 (14.5)	.64 (16.3)	.76 (19.3)	.76 (19.3)	1.02 (25.9)	1.27 (32.3)
K	3.56 (90.4)	4.62 (117.3)	5.37 (136.4)	6.69 (169.9)	7.75 (196.9)	9.31 (236.5)	12.19 (309.6)
L	.63 (16)	.86 (21.8)	1.01 (25.7)	1.07 (27.2)	1.04 (26.4)	1.51 (38.4)	2.01 (51.1)
M	.56 (14.2)	.81 (20.6)	.94 (23.9)	1.12 (28.4)	1.50 (38.10)	1.69 (42.9)	2.06 (52.3)
N	.75 (19.1)	1.25 (31.8)	1.50 (38.1)	1.75 (44.5)	2.00 (50.8)	2.68 (68.1)	4.00 (101.6)
P	.77 (19.6)	1.01 (25.7)	1.19 (30.2)	1.47 (37.3)	1.68 (42.7)	2.17 (55.1)	2.44 (62)
Q	³ / ₁₆ -.16 (.88)	³ / ₁₆ -.16 (1.06)	⁷ / ₁₆ -.14 (1.25)	¹ / ₁₆ -.12 (1.62)	¹ / ₁₆ -.12 (2.06)	¹ / ₁₆ -.12 (2.62)	¹ / ₁₆ -.12 (2.75)
R	1.29 (32.8)	1.80 (45.7)	1.82 (46.2)	2.17 (55.1)	2.42 (61.5)	2.79 (70.9)	3.67 (93.2)
S	6.00 (152.4)	8.00 (203.2)	9.76 (247.9)	11.26 (286)	13.76 (349.5)	17.13 (435.1)	20.50 (520.7)
T**	3.000 (76.20)	4.000 (101.60)	4.875 (123.83)	5.625 (142.88)	6.875 (174.63)	8.562 (217.47)	10.25 (260.35)
U	1.50 (38.1)	1.94 (49.3)	2.25 (57.2)	2.62 (66.5)	3.19 (81.0)	3.90 (99.1)	4.88 (123.9)
V	4.88 (123.9)	6.38 (162.1)	8.00 (203.2)	9.25 (234.9)	11.25 (285.8)	14.00 (355.6)	16.75 (425.5)
W	6.25 (158.8)	8.25 (209.6)	10.25 (260.4)	11.87 (301.5)	14.87 (377.7)	18.37 (466.6)	21.25 (539.8)
X	1.78 (45.2)	2.44 (61.9)	2.94 (74.7)	3.50 (88.9)	4.44 (112.8)	5.44 (138.2)	6.31 (160.3)
Y	2.61 (66.3)	3.41 (86.6)	4.28 (108.7)	4.94 (125.5)	6.06 (153.9)	7.44 (188.9)	8.81 (223.8)
Z	4.88 (123.9)	6.38 (162.1)	8.00 (203.2)	9.25 (234.9)	11.25 (285.8)	14.00 (355.6)	16.75 (425.5)
AA	.41 (10.4)	.53 (13.5)	.69 (17.5)	.81 (20.6)	.94 (23.9)	1.06 (26.9)	1.31 (33.3)
BB	7.12 (180.8)	9.62 (244.3)	11.75 (298.5)	13.62 (345.9)	17.00 (431.8)	21.00 (533.4)	24.50 (622.3)
CC	5.75 (146.1)	7.62 (193.5)	9.50 (241.3)	11.00 (279.4)	13.50 (342.9)	16.75 (425.5)	19.75 (501.7)
DD	3.38 (85.85)	3.94 (100.1)	4.50 (114.3)	5.75 (146.1)	6.62 (168.1)	8.00 (203.2)	9.62 (244.3)
EE	1.62 (41.1)	1.81 (45.9)	2.00 (50.8)	2.50 (63.5)	2.50 (63.5)	2.75 (69.9)	4.12 (104.6)
FF	.23 (5.8)	.34 (8.6)	.47 (11.9)	.72 (18.3)	.84 (21.3)	.84 (21.3)	.84 (21.3)

*± .0025 in. (0.064 mm)

** .005 in. (0.13 mm)

PERFORMANCE

SINGLE VANE 280° ROTATION (±1°)						
MODEL	TORQUE IN-LBS (N•m)			VOLUMETRIC DISPLACEMENT IN ³ (cm ³)		APPROX. WEIGHT LB (Kg)
	1000 PSI (69.0 BAR)	2000 PSI (137.9 BAR)	3000 PSI (206.9 BAR)	PER 280°	PER RAD	
	26R2	1720 (194.4)	3440 (388.7)	5160 (583.1)	9.35 (153.25)	
26R5	3900 (440.7)	7800 (881.4)	11700 (1322.1)	21.20 (347.47)	4.34 (71.13)	67 (30)
26R10	9100 (1028.5)	18200 (2056.6)	27300 (3084.9)	49.50 (811.31)	10.12 (165.87)	115 (52)
26R17	15200 (1717.6)	30400 (3435.2)	45600 (5152.8)	82.60 (1353.81)	16.90 (276.99)	207 (94)
26R31	27500 (3107.5)	55000 (6215)	82500 (9322.5)	149.50 (2450.31)	30.60 (501.55)	334 (152)
26R62	56000 (6328)	112000 (12656)	168000 (18984)	304.00 (4882.56)	62.20 (1019.46)	680 (308)
26R124	110000 (12430)	220000 (24860)	330000 (37290)	598.00 (9801.22)	122.00 (1999.58)	1221 (554)

DOUBLE VANE 100° ROTATION (±1°)						
MODEL	TORQUE IN-LBS (N•m)			VOLUMETRIC DISPLACEMENT IN ³ (cm ³)		APPROX. WEIGHT LB (Kg)
	1000 PSI (69.0 BAR)	2000 PSI (137.9 BAR)	3000 PSI (206.9 BAR)	PER 100°	PER RAD	
	26R2	3650 (412.5)	7300 (824.9)	10950 (1237.4)	6.67 (109.32)	
26R5	8240 (931)	16450 (1858.9)	24700 (2791.1)	15.10 (247.49)	8.68 (142.27)	70 (32)
26R10	19300 (2180.9)	38600 (4361.8)	57900 (6542.7)	35.40 (580.21)	20.24 (331.73)	124 (56)
26R17	32200 (3638.6)	64400 (7272.2)	96600 (10915.8)	59.00 (967.01)	33.80 (553.98)	225 (102)
26R31	58300 (6587.9)	116600 (13175.8)	174900 (19763.7)	106.80 (1750.45)	61.20 (1003.07)	363 (165)
26R62	118500 (13390.5)	237000 (26781)	355500 (40171.5)	217.00 (3556.63)	124.40 (2038.92)	730 (331)
26R124	232000 (26216)	464000 (52432)	696000 (78648)	427.00 (6998.53)	244.00 (3999.16)	1318 (598)

TEST PARAMETERS — OIL					
MODEL	MAX BREAK IN PSI (BAR)	BY-PASS LEAKAGE-MAX ALLOWABLE			
		CUBIC IN. PER MIN. AT 3000 PSI		CUBIC CM. PER MIN. AT 3000 PSI	
		(206.9 BAR)		(206.9 BAR)	
		1V	2V	1V	2V
26R2	150 (10.3)	6	8	98.3	131.1
26R5	140 (9.6)	6	8	98.3	131.1
26R10	130 (8.9)	8	10	131.1	163.9
26R17	120 (8.3)	8	10	131.1	163.9
26R31	110 (7.6)	10	12	163.9	196.7
26R62	100 (6.9)	10	12	163.9	196.7
26R124	90 (6.2)	12	15	196.7	245.9

NOTE: See how to order on page 13.

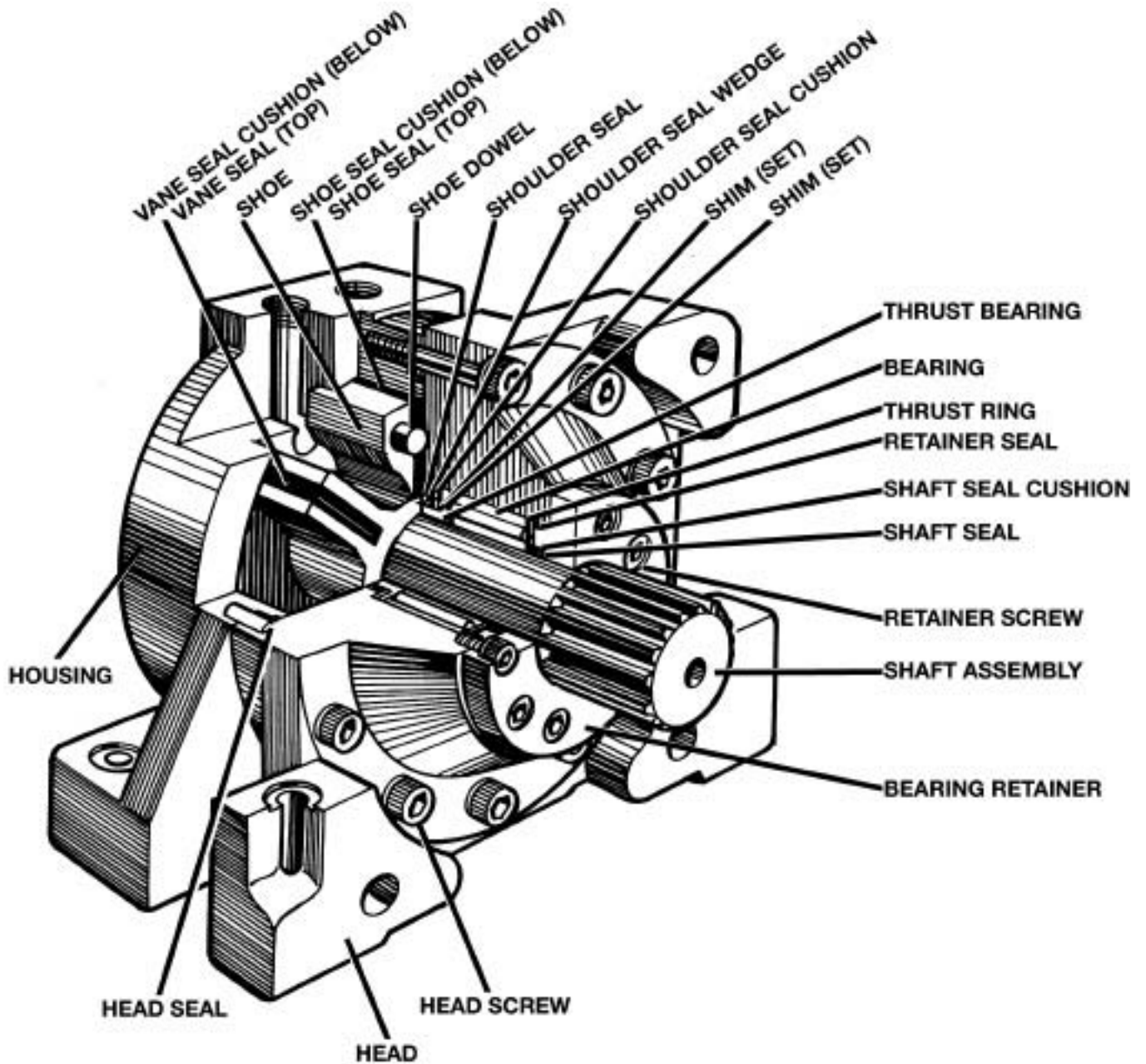

HOW TO ORDER

Sample: 26R 62 2V DE IS FT./FLG. OIL

Model _____	Fluid Medium Oil, Other
Size _____	Mounting Foot/Flange Special
Number of Vanes _____ 1V—Single Vane 2V—Double Vane	Shaft Type IS—30° Involute Spline Z—Special
Shaft Extension _____ SE—Single Extension DE—Double Extension	

If you require a special shaft extension, special mounting, air bleeds, special rotation control, or other special requirements, please enclose a drawing showing these requirements. Each number and letter has a specific meaning as shown in the sample.



Micromatic

HIGH PRESSURE

10 Standard Sizes

3,000 PSI

Up to 741,000 in/lbs of Torque

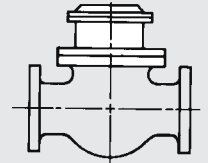
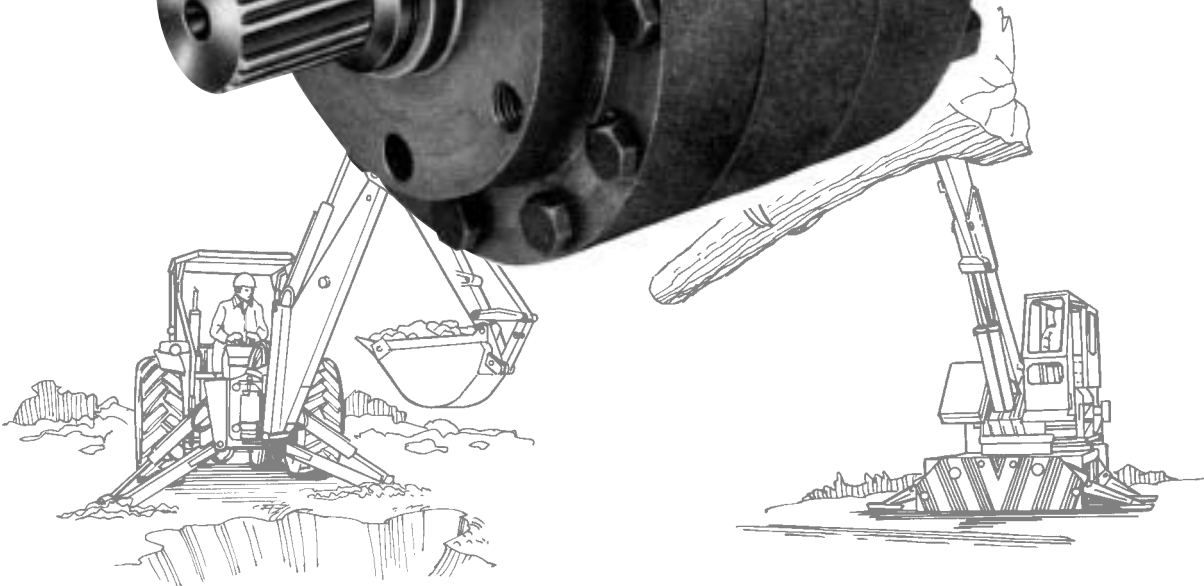
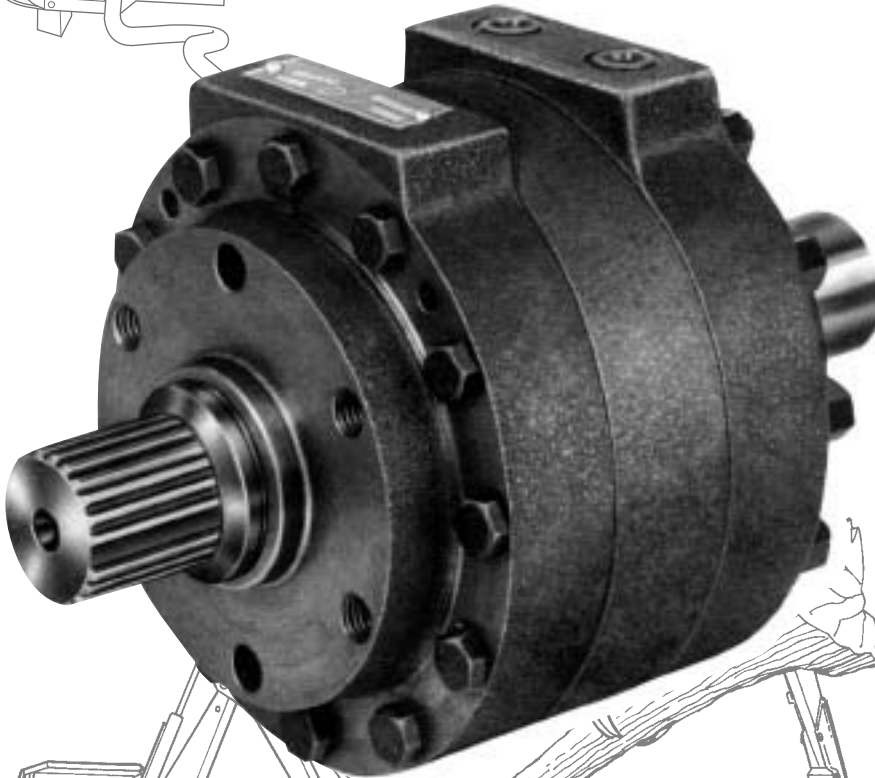
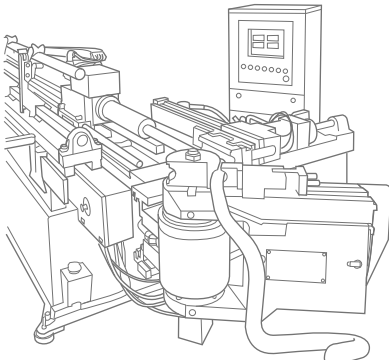

VALVE OPEN—CLOSE

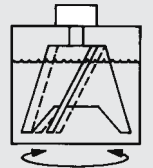

MIX—STIR

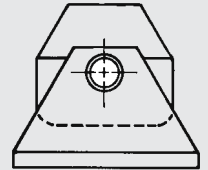

TURNOVER—DUMP

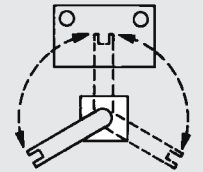

LOAD—POSITION—UNLOAD

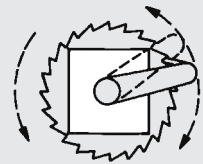

CONTINUOUS ROTATION



TURN—OSCILLATE

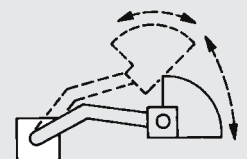

MATERIAL HANDLING

PROVIDING the “MUSCLE” for your lifting, turning, indexing, opening, closing, clamping, mixing, bending, testing, steering. . . **applications.**

SS MODELS

**HIGH PRESSURE *1
3000 PSI MAX**

BASE MOUNTING SS-2A & SS-5A

For larger aluminum units, please consult factory.

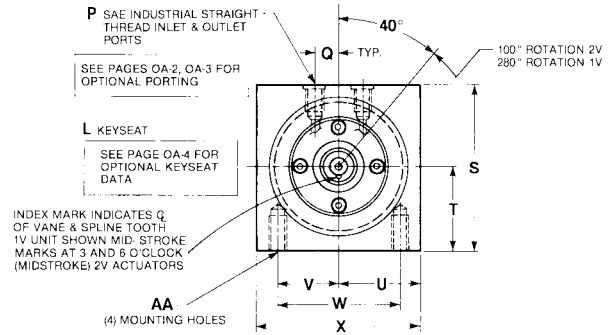
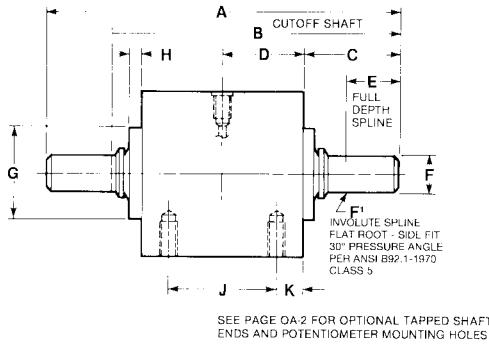

END MOUNTING SS-2A & SS-5A

For larger aluminum units, please consult factory.

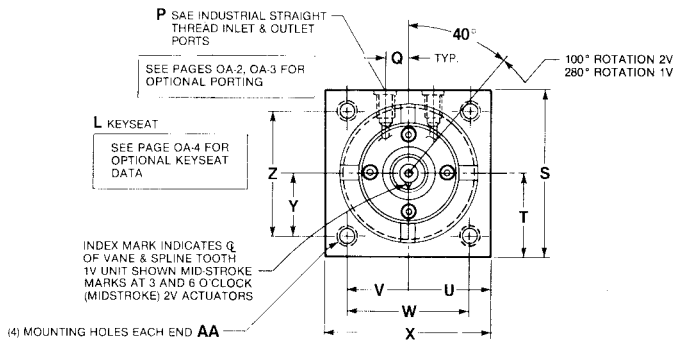
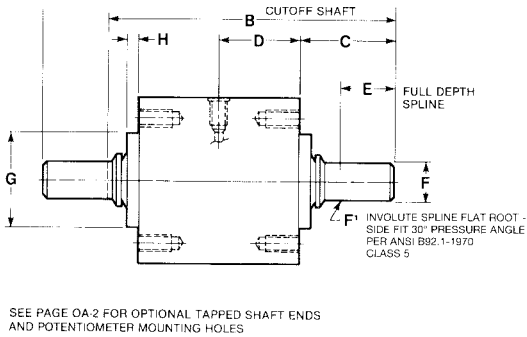

END MOUNTING SS-1 THRU SS-130

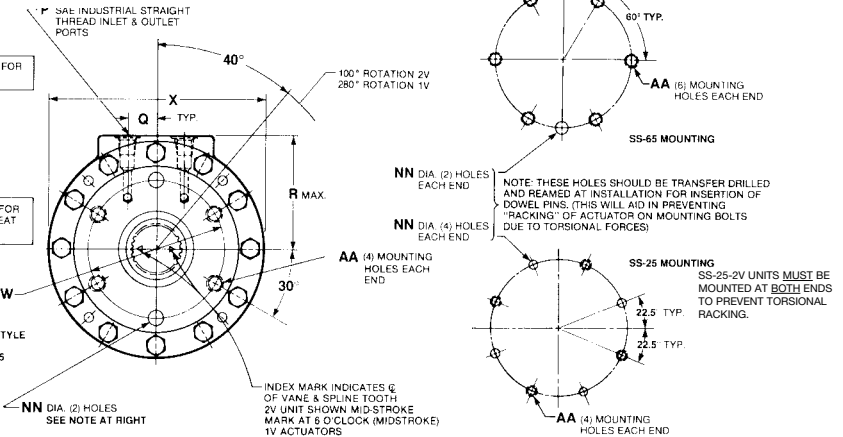
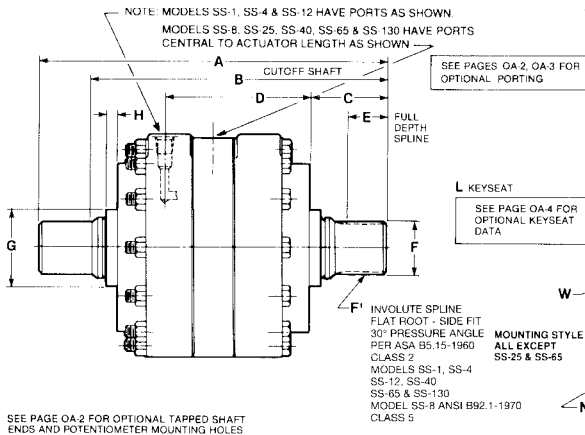

FOOT MOUNTING SS-1 THRU SS-130

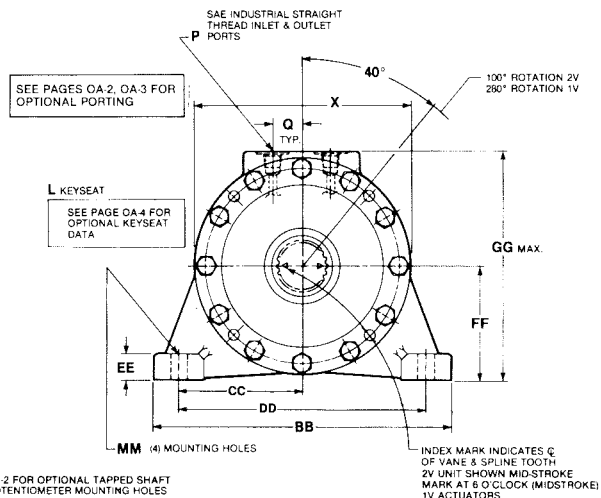
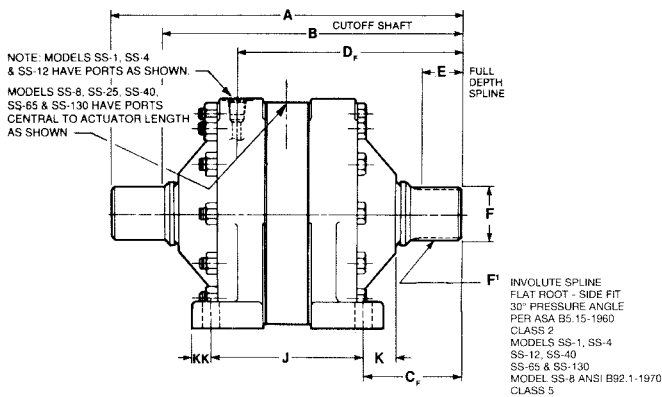

NOTE: See cut away view on page 17
NOTE: See pages 30 and 31 for optional manifolds and shaft couplings.

SEE PAGE OA-2 FOR OPTIONAL TAPPED SHAFT ENDS AND POTENTIOMETER MOUNTING HOLES

APPLICATION DATA DIMENSIONS IN INCHES (METRIC)

	SS-2A	SS-5A	SS-1	SS-4	SS-8	SS-12	SS-25	SS-40	SS-65	SS-130
A	5.00	6.50	7.66	10.50	11.69	14.12	21.28	20.06	23.75	29.75
B	(127.0)	(165.10)	(194.56)	(266.70)	(296.92)	(358.90)	(540.51)	(509.52)	(603.25)	(755.65)
C	3.89	5.05	6.91	9.05	9.85	11.94	17.06	16.35	19.75	23.50
D	(98.81)	(128.27)	(175.51)	(229.87)	(250.19)	(303.28)	(433.32)	(415.29)	(501.65)	(596.9)
E	1.38	1.75	1.38	2.34	3.28	3.31	5.81	5.06	6.26	8.12
F	(35.05)	(44.45)	(35.05)	(59.43)	(83.31)	(84.07)	(147.57)	(128.52)	(159.00)	(206.25)
G	—	—	2.19	2.94	3.28	4.00	5.52	5.38	6.26	8.75
H	(55.63)	(74.68)	(83.31)	(101.60)	(140.21)	(136.65)	(159.00)	(222.25)	(222.25)	(222.25)
I	1.13	1.50	3.35	4.40	3.00	5.75	4.81	4.96	6.38	6.75
J	(28.70)	(38.10)	(85.09)	(111.76)	(76.2)	(146.05)	(122.17)	(125.98)	(162.05)	(171.45)
K	—	—	4.69	6.75	5.64	9.06	10.64	10.03	11.95	14.87
L	(119.13)	(171.45)	(148.34)	(171.45)	(148.34)	(230.12)	(270.26)	(254.76)	(303.53)	(377.70)
M	.90	1.10	.59	1.22	1.75	1.89	3.27	3.27	3.88	5.50
N	(22.86)	(27.94)	(14.98)	(30.98)	(44.45)	(48.00)	(83.05)	(83.06)	(98.55)	(138.70)
O	.5935	.7145	1.0355	1.5452	1.9362	2.1962	3.3445	3.3445	3.8435	5.2935
P	(15.075)	(18.148)	(26.302)	(39.249)	(49.181)	(55.785)	(84.950)	(84.950)	(97.625)	(134.455)
Q	18T	22T	20T	24T	30T	26T	26T	26T	30T	31T
R	32/64P	32/64P	20/40P	16/32P	16/32P	12/24P	8/16P	8/16P	8/16P	8/12P
S	.5625PD	.5875PD	1.000PD	1.500PD	1.875PD	2.1667PD	3.2500PD	3.7500PD	3.7500PD	5.1667PD
T	1.44	1.70	1.63	2.25	3.25	3.25	6.00	4.75	6.50	10.25
U	(36.57)	(43.18)	(41.40)	(57.15)	(82.55)	(82.55)	(152.40)	(120.65)	(165.10)	(260.35)
V	.27	.22	.13	.34	.44	.56	1.38	.69	.75	1.13
W	(6.86)	(5.58)	(3.30)	(8.64)	(11.18)	(14.22)	(35.05)	(17.53)	(19.05)	(28.70)
X	1.75	2.00	3.27	4.62	5.12	6.12	10.25	9.3	11.38	12.25
Y	(44.45)	(50.80)	(83.06)	(117.35)	(130.05)	(155.45)	(260.35)	(236.22)	(289.05)	(311.15)
Z	.25	.50	.94	.94	.87	1.25	1.07	1.00	1.44	1.75
AA	(6.35)	(12.70)	(23.88)	(23.88)	(22.10)	(31.75)	(27.18)	(25.4)	(36.58)	(44.45)
AB	$\frac{1}{8} \times \frac{1}{16}$	$\frac{3}{16} \times \frac{3}{32}$	$\frac{1}{4} \times \frac{1}{8}$	$\frac{3}{8} \times \frac{3}{16}$	$\frac{1}{2} \times \frac{1}{4}$	$\frac{1}{2} \times \frac{1}{4}$	$\frac{3}{4} \times \frac{3}{8}$	$\frac{1}{2} \times \frac{1}{2}$	$1 \times \frac{1}{2}$	$1 \frac{1}{4} \times \frac{3}{8}$
AC	(3.17 x 1.58)	(4.76 x 2.38)	(6.35 x 3.17)	(9.52 x 4.76)	(12.70 x 6.35)	(12.70 x 6.35)	(19.05 x 9.52)	(19.05 x 9.52)	(25.4 x 12.70)	(31.75 x 15.87)
AD	.75	.70	.75	1.25	1.88	2.00	3.25	3.25	3.88	5.50
AE	(19.05)	(17.78)	(19.05)	(31.75)	(47.78)	(50.80)	(82.55)	(82.55)	(98.55)	(138.70)
AF	.375	.438	.50	.88	1.12	1.25	1.78	1.88	2.13	2.75
AG	(9.53)	(11.12)	(12.70)	(22.35)	(28.45)	(31.75)	(45.21)	(47.75)	(54.10)	(69.85)
AH	—	—	2.62	3.53	4.25	4.81	5.53	7.00	7.75	10.12
AI	(66.55)	(89.66)	(68.58)	(89.66)	(107.95)	(122.17)	(140.46)	(177.80)	(196.85)	(257.05)
AJ	2.25	3.00	—	—	—	—	—	—	—	—
AK	(57.15)	(76.20)	—	—	—	—	—	—	—	—
AL	1.13	1.50	—	—	—	—	—	—	—	—
AM	(28.70)	(38.10)	—	—	—	—	—	—	—	—
AN	1.13	1.50	—	—	—	—	—	—	—	—
AO	(28.70)	(38.10)	—	—	—	—	—	—	—	—
AP	.88	1.13	—	—	—	—	—	—	—	—
AQ	(22.35)	(28.70)	—	—	—	—	—	—	—	—
AR	1.75	2.25	2.63	4.13	5.00	5.63	9.00	8.75	9.00	13.50
AS	(44.45)	(57.15)	(66.80)	(104.90)	(127.00)	(143.00)	(228.60)	(222.25)	(228.60)	(342.90)
AT	2.25	3.00	4.88	6.65	8.41	9.15	10.44	13.50	15.00	20.00
AU	(57.15)	(76.2)	(123.95)	(168.91)	(213.61)	(232.41)	(265.18)	(342.90)	(381.00)	(508.00)
AV	.88	1.13	—	—	—	—	—	—	—	—
AW	(22.35)	(28.70)	—	—	—	—	—	—	—	—
AX	1.75	2.25	—	—	—	—	—	—	—	—
AY	(44.45)	(57.15)	—	—	—	—	—	—	—	—
AZ	$\frac{1}{4}$ -20	$\frac{3}{16}$ -18	$\frac{3}{8}$ -16	$\frac{1}{2}$ -13	$\frac{1}{2}$ -13	$\frac{3}{8}$ -11	$\frac{3}{8}$ -11	$\frac{3}{4}$ -10	$\frac{3}{4}$ -10	1-8
BA	.31DP	.62DP	.75DP	1.0DP	1.0DP	1.25DP	1.25DP	1.50DP	1.25DP	2.0DP
BB	(7.87)	(15.75)	(19.05)	(25.40)	(25.40)	(31.75)	(31.75)	(38.10)	(31.75)	(50.80)
BC	—	—	6.50	9.00	11.00	11.88	13.00	15.25	19.00	25.25
BD	(165.10)	(228.60)	(228.60)	(228.60)	(279.40)	(301.75)	(330.20)	(387.35)	(482.60)	(641.35)
BE	—	—	2.75	3.75	4.75	5.06	5.00	6.50	8.00	11.00
BF	(69.85)	(95.25)	(95.25)	(120.65)	(120.65)	(128.52)	(127.00)	(165.10)	(203.20)	(279.40)
BG	—	—	5.50	7.50	9.50	10.13	10.00	13.00	16.00	22.00
BH	(139.70)	(190.50)	(241.30)	(257.30)	(254.00)	(330.20)	(330.20)	(405.40)	(405.40)	(558.80)
BI	—	—	.63	.75	.94	.94	1.25	1.13	1.69	1.50
BJ	(16.00)	(19.05)	(23.88)	(23.88)	(31.75)	(28.70)	(42.93)	(38.10)	(42.93)	(38.10)
BK	—	—	2.50	3.38	4.375	4.63	5.38	6.88	7.875	10.13
BL	(63.50)	(85.85)	(111.13)	(117.60)	(136.65)	(174.75)	(200.03)	(257.30)	(257.30)	(257.30)
BM	—	—	5.13	6.91	8.63	9.44	10.75	13.75	15.63	20.25
BN	(130.30)	(175.51)	(219.20)	(239.78)	(273.05)	(349.25)	(397.00)	(514.35)	(514.35)	(514.35)
BO	—	—	.50	.63	.91	.88	1.07	1.00	1.44	1.62
BP	(12.70)	(16.00)	(23.11)	(22.35)	(27.18)	(25.40)	(36.58)	(41.11)	(41.11)	(41.11)
BQ	—	—	.41	.53	.69	.78	.97	1.06	1.31	1.56
BR	(10.41)	(13.46)	(17.53)	(23.88)	(23.88)	(33.27)	(26.92)	(33.27)	(39.62)	(39.62)
BS	—	—	.41	.47	.47	.59	.62	.84	.84	1.22
BT	(10.41)	(11.94)	(14.98)	(15.75)	(15.75)	(21.3)	(21.3)	(21.3)	(30.99)	(30.99)
BU	—	—	.75DP	.75DP	.75DP	1.25DP	1.25DP	1.50DP	1.50DP	2.00DP
BV	(19.05)	(19.05)	(19.05)	(19.05)	(19.05)	(31.75)	(44.45)	(44.45)	(38.10)	(50.80)

* ± .0005 in. (0.013 mm) SS-2A, SS-5A, SS-1 ± .00075 in. (0.019 mm) SS-4, SS-8, SS-12 ± .0015 in. (0.038 mm) SS-25, SS-40

** ± .0025 in. (0.064 mm) SS-65, SS-130

*** ± .005 (.013 mm)

Model SS-25 has (4) holes on a 90° pattern rotated 22 1/2° counter-clockwise

*1 2000 PSI maximum is recommended for severe duty applications, such as operating at maximum torque at high cycle rates for extended periods. Please consult factory for applications beyond 2000 PSI.

NOTE: See how to order on page 17.

PERFORMANCE

MODEL	TORQUE IN-LBS (N•m)			VOLUMETRIC DISPLACEMENT IN ³ (CM ³)		APPROX. WEIGHT LB (Kg)
	1000 PSI (69.0 BAR)	2000 PSI (137.9 BAR)	3000 PSI (206.9 BAR)	PER 280°	PER RAD	
	SINGLE VANE 280° ROTATION (±5°)					
SS-2A	170 (19)	340 (38)	510 (58)	.95 (15.57)	.2 (3.27)	1.6 (.73)
SS-5A	380 (43)	760 (86)	—	2.18 (35.73)	.45 (7.37)	3.0 (1.36)
SS-1	1080 (122)	2160 (244)	3240 (366)	5.85 (95.88)	1.20 (19.66)	21.5 (9.75)
SS-4	3430 (388)	6860 (775)	10300 (1164)	18.59 (304.69)	3.81 (62.44)	48.5 (23)
SS-8	7200 (814)	14400 (1627)	21600 (2440)	39.04 (639.86)	8.00 (131.12)	78 (35)
SS-12	11210 (1266)	22420 (2533)	33615 (3798)	60.75 (995.69)	12.45 (204.05)	121.5 (55)
SS-25	22410 (2532)	44820 (5065)	67230 (7597)	121.51 (1991.54)	24.90 (408.11)	220 (100)
SS-40	36000 (4068)	72000 (8136)	108000 (12204)	195.20 (3199.32)	40.00 (655.60)	355 (161)
SS-65	58500 (6611)	117000 (13221)	175500 (19831)	317.20 (5198.90)	65.00 (1065.35)	560 (254)
SS-130	117000 (13221)	234000 (26442)	351000 (39663)	634.40 (10397.81)	130 (2130.70)	975 (442)

MODEL	TORQUE IN-LBS (N•m)			VOLUMETRIC DISPLACEMENT IN ³ (CM ³)		APPROX. WEIGHT LB (Kg)
	1000 PSI (69.0 BAR)	2000 PSI (137.9 BAR)	3000 PSI (206.9 BAR)	PER 100°	PER RAD	
	DOUBLE VANE 100° ROTATION (±5°)					
SS-2A	—	—	—	—	—	—
SS-5A	810 (91)	1620 (183)	—	1.57 (25.73)	.90 (14.75)	3.2 (1.45)
SS-1	2280 (257)	4560 (515)	6840 (773)	4.18 (68.51)	2.40 (39.33)	22 (10)
SS-4	7230 (817)	14460 (1634)	21700 (2452)	13.29 (217.82)	7.62 (124.89)	50 (23)
SS-8	15200 (1718)	30400 (3435)	45600 (5153)	27.92 (457.60)	16 (262.24)	80 (36.29)
SS-12	23660 (2673)	47320 (5347)	70965 (8019)	43.45 (712.14)	24.90 (408.11)	125 (57)
SS-25	47310 (5346)	94620 (10692)	141930 (16038)	86.41 (1416.31)	49.80 (816.22)	230 (104)
SS-40	76000 (8588)	152000 (17176)	228000 (25764)	139.61 (2288)	80.00 (1311)	370 (168)
SS-65	123500 (13955)	247000 (27911)	370500 (41866)	226.87 (3718)	130 (2130)	582 (264)
SS-130	247000 (27911)	494000 (55822)	741000 (83733)	453.75 (7436)	260 (4261)	1035 (469)

MODEL	MAX BREAK IN PSI (BAR)	BY-PASS LEAKAGE—MAX ALLOWABLE		
		CUBIC IN. PER MIN. AT 3000 PSI (206.9 BAR)	CUBIC CM. PER MIN. AT 3000 PSI (206.9 BAR)	
		1V	1V 2V	
SS-2A	125 (8.6)	10	200	N/A
SS-5A	125 (8.6)	12	180	200
SS-1	100 (6.90)	14	229	295
SS-4	50 (3.44)	16	262	370
SS-8	50 (3.44)	18	295	N/A
SS-12	50 (3.44)	20	328	470
SS-25	50 (3.44)	22	360	N/A
SS-40	50 (3.44)	25	410	1080
SS-65	50 (3.44)	28	459	1370
SS-130	50 (3.44)	43	704	1550

† TESTED AT 2250 PSI.

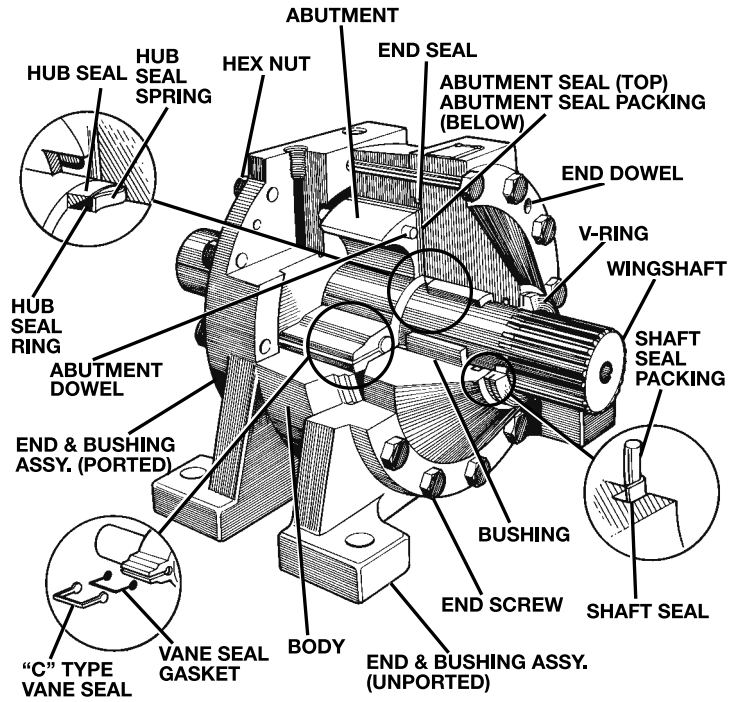
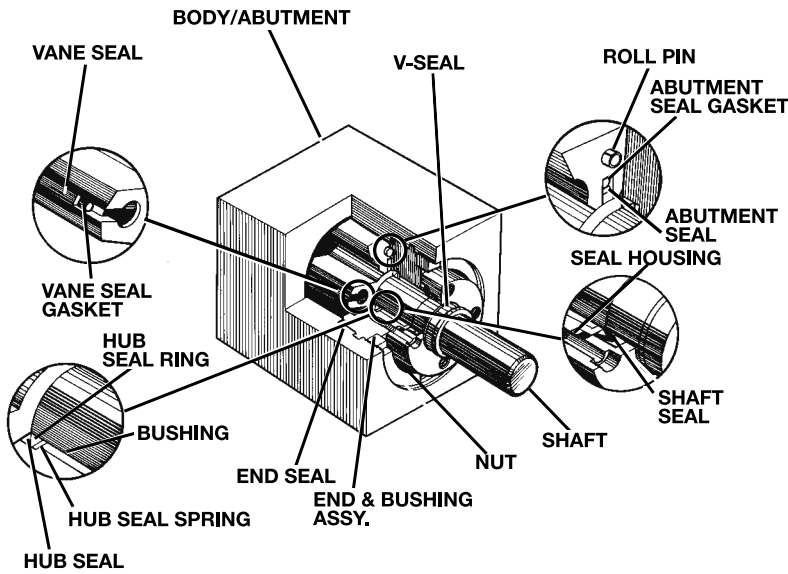

HOW TO ORDER

Please fill in ALL blocks in accordance with the KEY numbers and letters shown below.

Block #

1 2 3 4 5 6 7 8

Block 1 (STYLE)

SS Solid Shaft
PP Special

Block 2 (SIZE)

*0.2A
*0.5A
1
4
8
12
25
40
65
130

Block 3 (NO. OF VANES)

1V Single vane
2V Double vane

Block 4 (MOUNTING)

E End
F Foot
B Base
Z Special

Block 5 (SEALS)

B Buna "N" Standard shaft seal
V Viton Standard shaft seal
E Ethylene propylene
X Two piece end—Viton shaft seal buna seals
Y Two piece end—Viton shaft seal viton seals
Z Special

Block 6 (SHAFT CONFIGURATION)

A Standard (Involute spline & plain for SS)
B Plain end cut off
C Plain both ends
D Plain one end—Single key other end
E Plain one end—Double key other end
F Plain end cut off—Single key other end
G Plain end cut off—Double key other end
H Single key both ends
J Double key both ends
K Spline one end—Single key other end
L Spline one end—Double key other end
N Splined both ends
Z Special

Block 7 (SHAFT MODIFICATION)

A Standard (None)
B Drill, tap drive end of shaft
C Drill, tap both ends of shaft
***D Potentiometer shaft hole opp drive end
E Drill & tap end opposite drive end
Z Special

Block 8 (PORTING)

1 N.P.T.
2 SAE Straight threads standard
3 Double N.P.T. ports
4 Double SAE ports
** 5 Front ports—N.P.T.
** 6 Front ports—SAE
7 Manifold ports (See manifold porting data for explanation)
8 Body ports—N.P.T.
9 Double manifold ports
0 BSPP straight threads
Z Special

* For Aluminum units an A is added to the key
Example: SS-.05A-1V is an Aluminum Actuator
SS-4-1V is a Cast Iron Actuator

** "Front ports" for end ported SS Series means adjacent to keyed or spline shaft end.

*** See Page 27 for size.



Micromatic

HIGH PRESSURE - HOLLOW SHAFT

6 Standard Sizes

3,000 PSI

Up to 57,000 in/lbs of Torque

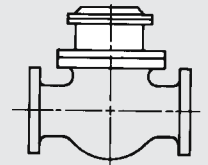
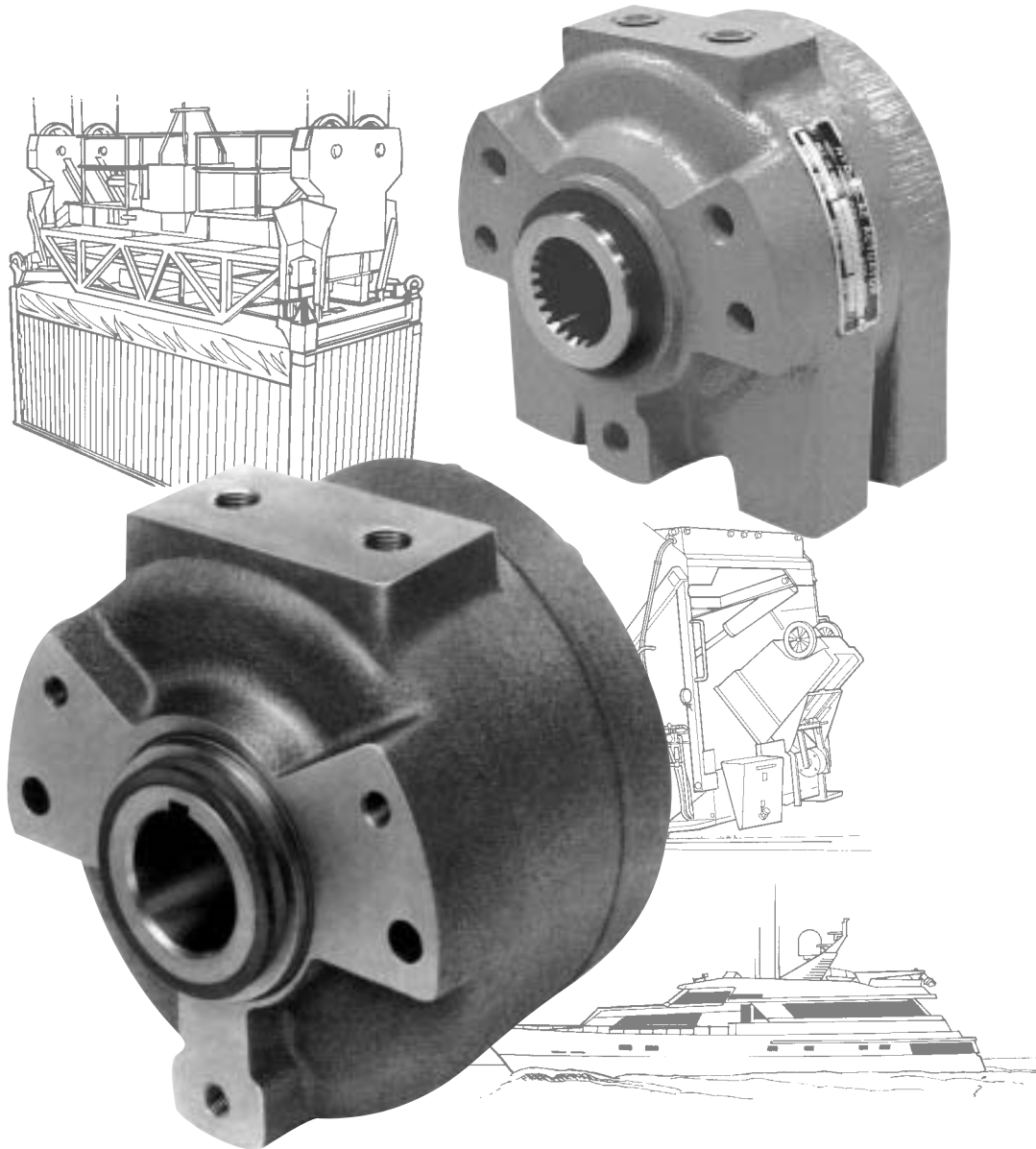

VALVE OPEN—CLOSE

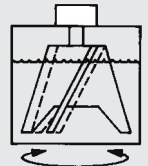

MIX—STIR

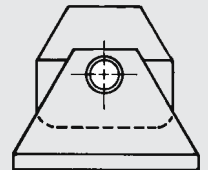

TURNOVER—DUMP

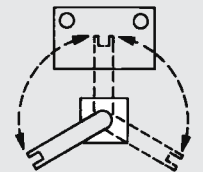

LOAD—POSITION—UNLOAD

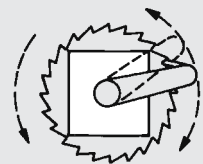

CONTINUOUS ROTATION



TURN—OSCILLATE

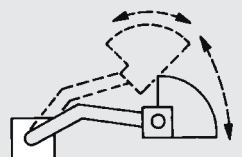

MATERIAL HANDLING

PROVIDING the “MUSCLE” for your lifting, turning, indexing, opening, closing, clamping, mixing, bending, testing, steering . . . **applications.**

HS MODELS

**END MOUNTING
HIGH PRESSURE 3000 PSI *1**

SINGLE VANE HS-1.5, HS-2.5, HS-4

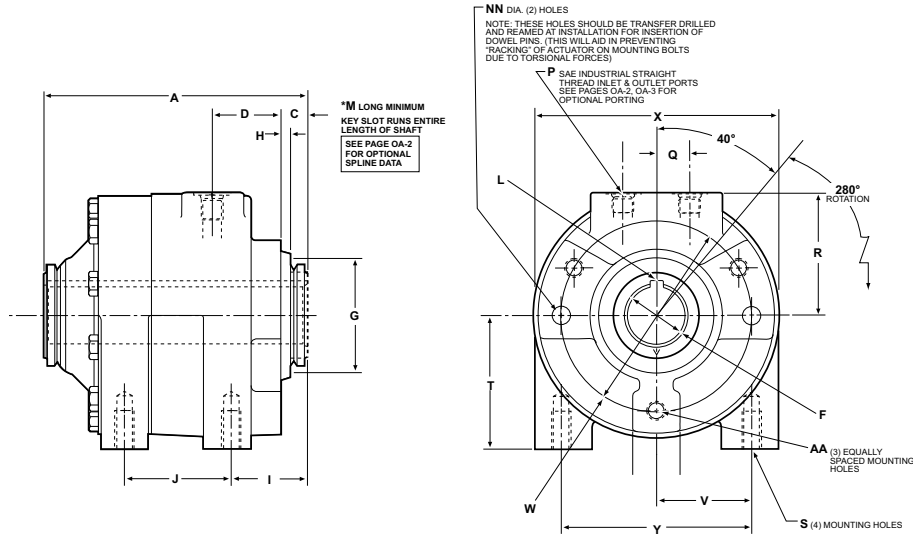

SINGLE VANE HS-6, HS-10, HS-15

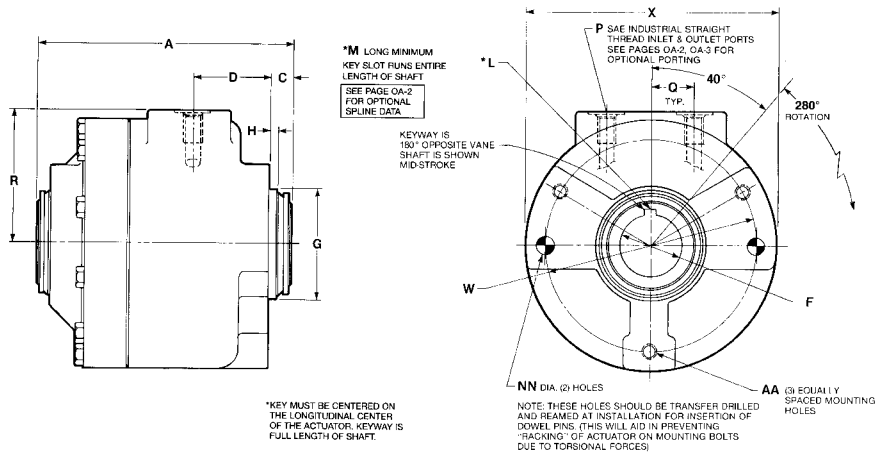

DOUBLE VANE

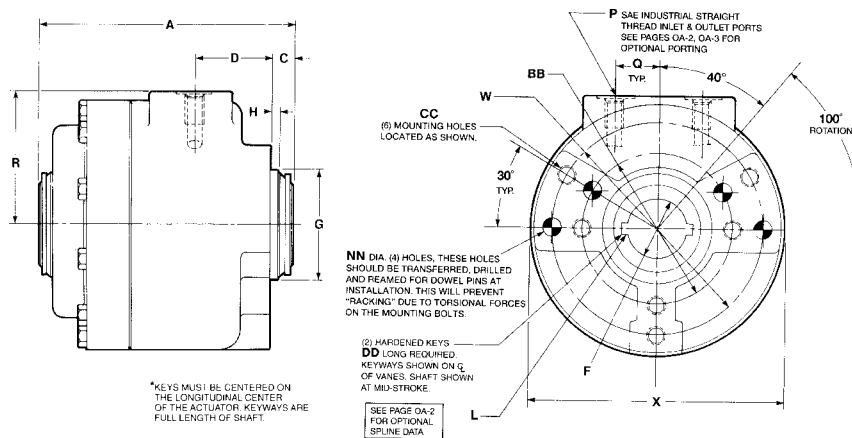

NOTE: See cut away view of 1V model on page 21.

NOTE: See pages 30 for optional manifold.

***1 2000 PSI maximum is recommended for severe duty applications, such as operating at maximum torque at high cycle rates for extended periods. Please consult factory for applications beyond 2000 PSI. 3000 PSI can be used on intermittent shockless actuations.**

APPLICATION DATA DIMENSIONS IN INCHES (METRIC)

	HS-1.5	HS-2.5	HS-4	HS-6	HS-10	HS-15
A	6.12 (155.45)	6.92 (175.77)	8.12 (206.25)	7.25 (184.15)	8.25 (209.55)	9.97 (253.24)
C	.69 (17.53)	.69 (17.53)	.69 (17.53)	.69 (17.53)	.69 (17.53)	.69 (17.53)
D	1.81 (45.97)	1.81 (45.97)	1.81 (45.97)	2.50 (63.50)	2.50 (63.50)	2.50 (63.50)
① F	1.5020 (38.151)	1.5020 (38.151)	1.5020 (38.151)	2.0025 (50.864)	2.0025 (50.864)	2.0025 (50.864)
② G	2.9990 (76.175)	2.9990 (76.175)	2.9990 (76.175)	3.6240 (92.050)	3.6240 (92.050)	3.6240 (92.050)
⑤ H	.25 (6.35)	.25 (6.35)	.25 (6.35)	.25 (6.35)	.25 (6.35)	.25 (6.35)
I	2.00 (50.8)	2.00 (50.8)	2.00 (50.8)	2.00 (50.8)	2.00 (50.8)	2.00 (50.8)
J	2.00 (50.8)	2.80 (71.12)	4.00 (101.6)			
③ L	$\frac{5}{16} \times \frac{5}{32}$ (7.94 x 3.96)	$\frac{5}{16} \times \frac{5}{32}$ (7.94 x 3.96)	$\frac{5}{16} \times \frac{5}{32}$ (7.94 x 3.96)	$\frac{3}{8} \times \frac{3}{16}$ (9.53 x 4.76)	$\frac{3}{8} \times \frac{3}{16}$ (9.53 x 4.76)	$\frac{3}{8} \times \frac{3}{16}$ (9.53 x 4.76)
M	1.38 (35.03)	2.25 (57.15)	3.50 (88.90)	3.00 (76.2)	4.50 (114.30)	7.00 (177.80)
④ P	$\frac{9}{16}$ -18 (22.352)	$\frac{9}{16}$ -18 (22.352)	$\frac{9}{16}$ -18 (22.352)	$\frac{3}{4}$ -18 (36.50)	$\frac{3}{4}$ -16 (36.50)	$\frac{3}{4}$ -16 (36.50)
Q	.88 (22.352)	.88 (22.352)	.88 (22.352)	1.437 (36.50)	1.437 (36.50)	1.437 (36.50)
R	3.22 (81.79)	3.22 (81.79)	3.22 (81.79)	4.44 (112.78)	4.44 (112.78)	4.44 (112.78)
S	$\frac{1}{2}$ -13 1.00 DP	$\frac{1}{2}$ -13 1.00 DP	$\frac{1}{2}$ -13 1.00 DP			
T	3.50 (88.9)	3.50 (88.9)	3.50 (88.9)			
V	2.50 (63.5)	2.50 (63.5)	2.50 (63.5)			
W	5.00 (127.00)	5.00 (127.00)	5.00 (127.00)	7.00 (177.80)	7.00 (177.80)	7.00 (177.80)
X	6.25 (158.75)	6.25 (158.75)	6.25 (158.75)	8.50 (215.90)	8.50 (215.90)	8.50 (215.90)
④ Y	5.00 (127.00)	5.00 (127.00)	5.00 (127.00)			
AA	$\frac{1}{2}$ -13 1.00 DP	$\frac{1}{2}$ -13 1.00 DP	$\frac{1}{2}$ -13 1.00 DP	$\frac{1}{2}$ -13 1.00 DP	$\frac{1}{2}$ -13 1.00 DP	$\frac{1}{2}$ -13 1.00 DP
BB	— (25.4)	— (25.4)	— (25.4)	5.00 (127.0)	5.00 (127.0)	5.00 (127.0)
CC	—	—	—	$\frac{5}{8}$ -11 (28.7)	$\frac{5}{8}$ -11 (28.7)	$\frac{5}{8}$ -11 (28.7)
DD	—	—	—	1.13 DP (28.7)	1.13 DP (28.7)	1.13 DP (28.7)
NN	— .468 (11.89)	— .468 (11.89)	— .468 (11.89)	7.25 .593 (15.06)	8.25 .593 (15.06)	9.97 .593 (15.06)
	1.25 DP (31.75)	1.25 DP (31.75)	1.25 DP (31.75)	1.25 DP (31.75)	1.25 DP (31.75)	1.25 DP (31.75)

- ① TOLERANCE ± .001 (0.0254) HS-1.5, 2.5, 4
± .0015 (0.038) HS-6, 10, 15
- ② TOLERANCE ± .001 (0.0254)
- ③ SEE PAGE OA-2 FOR OPTIONAL SPLINE DATA
- ④ SEE PAGES OA-2, OA-3 FOR OPTIONAL PORT DATA
- ⑤ TOLERANCE ± .001

PERFORMANCE

SINGLE VANE 280° ROTATION (±5°)						
MODEL	TORQUE IN-LBS (N•m)			VOLUMETRIC DISPLACEMENT IN ³ (cm ³)		APPROX. WEIGHT LB (Kg)
	1000 PSI (69.0 BAR)	2000 PSI (137.9 BAR)	3000 PSI (206.9 BAR)	PER 280°	PER RAD	
	HS-1.5	1350 (152.55)	2700 (305.10)	4050 (457.65)	7.30 (119.64)	
HS-2.5	2250 (254.25)	4500 (508.50)	6750 (762.75)	12.20 (199.95)	2.50 (40.97)	34 (15.42)
HS-4	3600 (406.80)	7200 (813.60)	10800 (1220.40)	19.54 (320.26)	4.00 (65.56)	41 (18.59)
HS-6	5720 (646.36)	11440 (1292.72)	17160 (1939.08)	31.05 (508.90)	6.36 (104.24)	58 (26.30)
HS-10	8600 (971.80)	17200 (1943.60)	25800 (2915.40)	46.59 (763.61)	9.54 (156.36)	67 (30.39)
HS-15	13500 (1525.50)	27000 (3051.00)	40500 (4576.50)	73.27 (1200.89)	15.00 (245.85)	83 (37.64)

DOUBLE VANE 100° ROTATION (±5°)						
MODEL	TORQUE IN-LBS (N•m)			VOLUMETRIC DISPLACEMENT IN ³ (cm ³)		APPROX. WEIGHT LB (Kg)
	1000 PSI (69.0 BAR)	2000 PSI (137.9 BAR)	3000 PSI (206.9 BAR)	PER 100°	PER RAD	
	HS-1.5			NA		
HS-2.5			NA			
HS-4			NA			
HS-6	12080 (1365.04)	24170 (2731.21)	36250 (4096.25)	22.20 (363.86)	12.72 (208.48)	68 (30.84)
HS-10	18120 (2047.56)	36250 (4096.25)	54370 (6143.81)	33.29 (545.62)	19.08 (312.72)	76 (34.47)
HS-15	28500 (3220.50)	57000 (6441.00)	NA	52.70 (863.75)	30.02 (492.03)	95 (43.08)

TEST PARAMETERS — OIL			
MODEL	MAX BREAK IN PSI (BAR)	BY-PASS LEAKAGE-MAX ALLOWABLE	
		CUBIC IN. PER MIN. AT 3000 PSI (206.9 BAR)	CUBIC CM. PER MIN. AT 3000 PSI (206.9 BAR)
HS-1.5	80 (5.52)	5	82
HS-2.5	80 (5.52)	6	98
HS-4	80 (5.52)	7	115
HS-6	50 (3.44)	8	131
HS-10	50 (3.44)	9	148
HS-15	50 (3.44)	10	164

NOTE: See how to order on page 21.

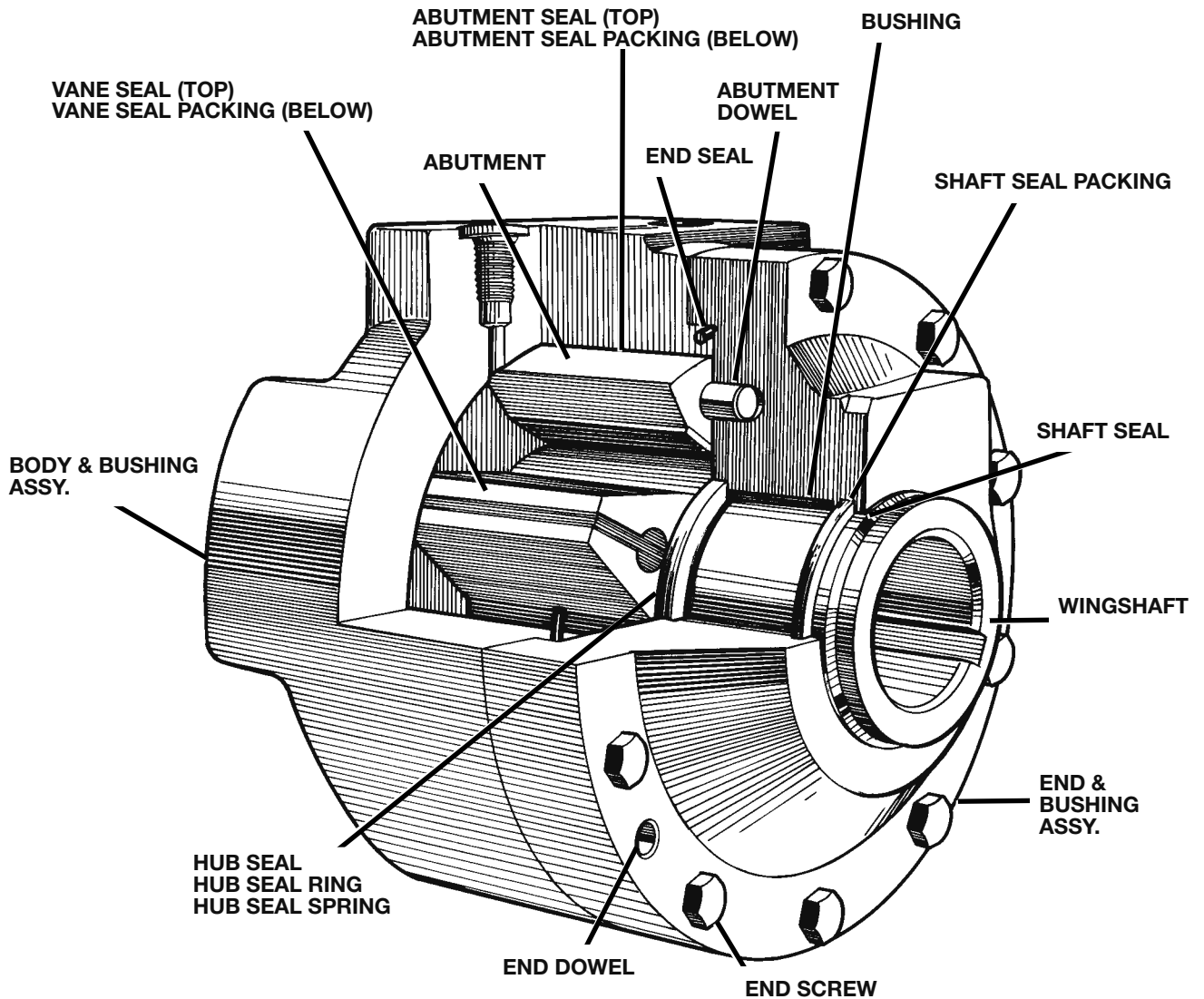

HOW TO ORDER

Please fill in ALL blocks in accordance with the KEY numbers and letters shown below.

Block #

1 2 3 4 5 6 7 8

Block 1 (STYLE)

HS Hollow shaft

Block 2 (SIZE)

1½

2½

4

6

10

15

Block 3 (NO. OF VANES)

1V Single vane

2V Double vane

Block 4 (MOUNTING)

E End

B Base (Available in sizes 1-1/2, 2-1/2 & 4 only.)

Block 5 (SEALS)

B Buna "N" Standard shaft seal

V Viton Standard shaft seal

E Ethylene propylene

Z Special

Block 6 (SHAFT CONFIGURATION)

A Standard (Internal key for HS)

M Internal spline (HS)

Z Special

Block 7 (SHAFT MODIFICATION)

A Standard (None)

Z Special

Block 8 (PORTING)

1 N.P.T.

2 SAE Straight threads standard

** 5 End ports—N.P.T.

** 6 End ports—SAE

7 Manifold ports (See manifold porting data for explanation)

0 BSPP straight threads

Z Special

** "End ports" for HS Series means on non-mounting end, parallel to shaft.

Not available on 2V units.



Micromatic

8 Standard Sizes

1,000 PSI

Up to 43,150 in/lbs of Torque

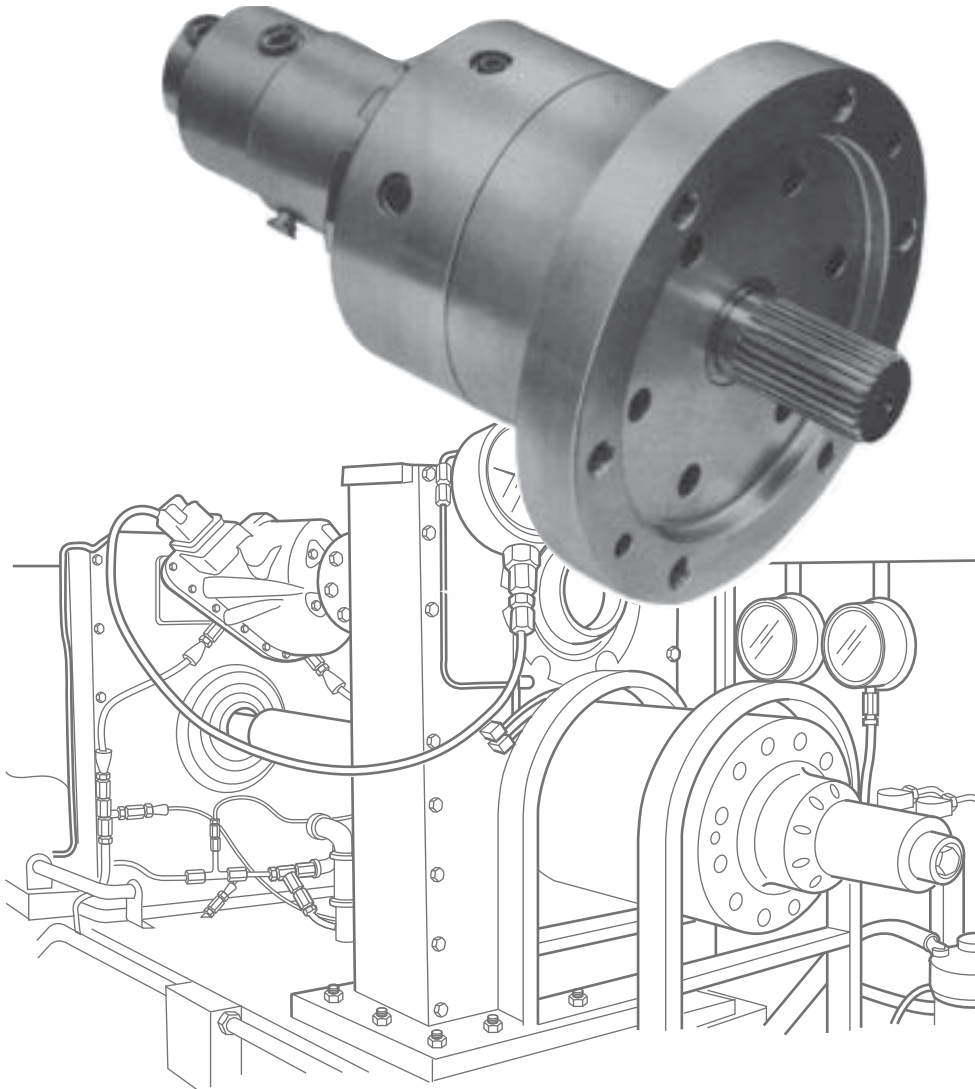

PROVIDING the “MUSCLE” for your clamping, twisting, testing. . . **applications.**

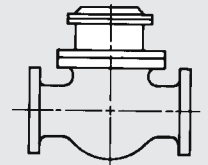

VALVE OPEN—CLOSE

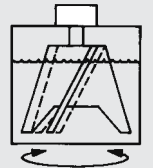

MIX—STIR

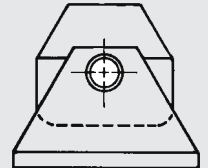

TURNOVER—DUMP

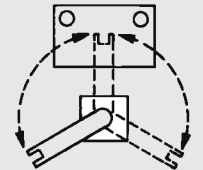

LOAD—POSITION—UNLOAD

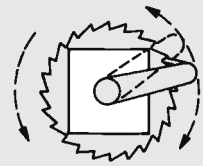

CONTINUOUS ROTATION



TURN—OSCILLATE

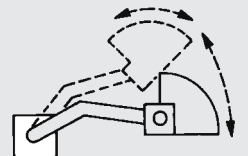

MATERIAL HANDLING

ROTATING ACTUATORS

The Rotating actuator is a new innovation of reciprocating torque actuators. Its interior design and construction are similar to standard lines of stationary actuators, but the Rotating actuator, unlike the stationary models, revolves in application. Also, its applications are entirely different.

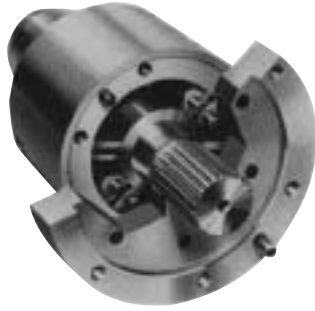

It consists of an aluminum alloy body with a precision machined cylindrical chamber, a central splined-end shaft on which vanes are fixed, and barriers or shoes that provide positive internal stops for the vanes. The number of vanes and shoes within the unit limit the arc of vane travel and effect the torque output capacities.

Power is derived from either hydraulic or pneumatic pressure directed against the vanes which, in turn, rotate the splined shaft. Although the shoes limit the movement of the vanes to a precise maximum degree, any required arc of movement can be controlled by valves and external positive stops. Infinitely variable, increasing and decreasing, and sudden loads can be applied.

Reciprocating torque actuators, like most power outputs, are usually mounted to a stationary base. But the Rotating actuator revolves in application as an integral part of a functioning device: the body, vanes, and shaft rotate in unison, maintaining their relationship until fluid pressure changes the position of the vanes.

APPLICATIONS

DRAWING A. Centrifugal, bending, and torque testing of couplings, fatigue specimens, and universal joints is done in this typical arrangement. The Rotating Rotac actuator supplies the torque load, stress, or shock the items.

DRAWING B. Two automotive differentials are tested in this arrangement. The Rotating Rotac actuator's reciprocal capabilities impose continuous forward, reverse and variable action plus shock loading on the specimens.

DRAWING C. In chucking lathe applications, the Rotating Rotac actuator actuates the jaws of the chuck, and shifts the locations of the work for eccentric turning during the machining cycle.

DRAWING D. In a gear testing arrangement, an electric motor drives the entire assembly, including the Rotating Rotac actuator. Hydraulic power input to the Rotac actuator imposes load or shock to the gear train.

It Works Like This:

In applications such as machining, the Rotating actuator is mounted to the spindle and rotates at the same speed. When fluid pressure is applied, it either advances or reverses the relative position of the vanes — therefore the shaft — to supply the necessary movement, or torque, as the job requires. In test and fatigue applications, the Rotating actuator is mounted remote of the power source but as an integral unit of entire driving assembly. Its function is to impose torque circulating within the driven assembly but independent of the rotating power source. Controlled fluid

pressure on the vanes within the actuator apply load, or shock as the test may require, on the driven specimens.

In applications and illustrations shown in this brochure, the Rotating actuator is equipped with a hydraulic union for pressure input. Similar devices can be used to accommodate pneumatic pressure.

Rotating actuators are designed in "small" and "medium" models with two and three vanes to provide torque outputs for many applications. The following drawings, specifications lists, and charts will help to pinpoint the exact model to suit a given purpose. In addition to this information engineering service is available through your field representative, or through the factory for application assistance and special designs.

Engineering Data

Standard rotating actuators use Deublin Rotating Hyd. Deu-Plex unions with special features

Max. R.P.M. — 5,000 @ 750 PSI Max.

Max. Air Pressure 150 PSI

NOTE: Lubricated air is required for pneumatic operation.

NOTE: Splined couplings are available.

NOTE: Unless otherwise specified, units are dynamically balanced per ISO 1940 G 2.5 from diameters indicated with ▲

TORQUE RATINGS IN INCH-POUNDS P.S.I.

Model	100	200	400	500	600	750
SS-2V	400	850	1,700	2,100	2,550	3,100
SS-3V	600	1,350	2,650	3,300	3,950	4,900
SL-2V	850	1,700	3,400	4,200	5,000	6,250
SL-3V	1,300	2,650	5,300	6,600	7,900	9,850
MS-2V	2,000	3,550	7,500	9,250	11,000	13,600
MS-3V	3,000	6,000	11,500	14,500	17,500	21,550
ML-2V	3,750	7,500	15,000	18,500	22,000	27,650
ML-3V	6,000	12,000	23,500	29,500	35,000	43,150

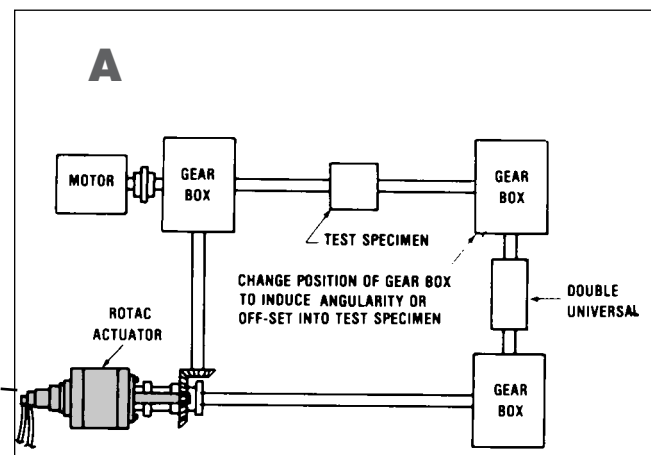

NOTE: See cut away view on page 25.

ROTATING ACTUATORS SMALL

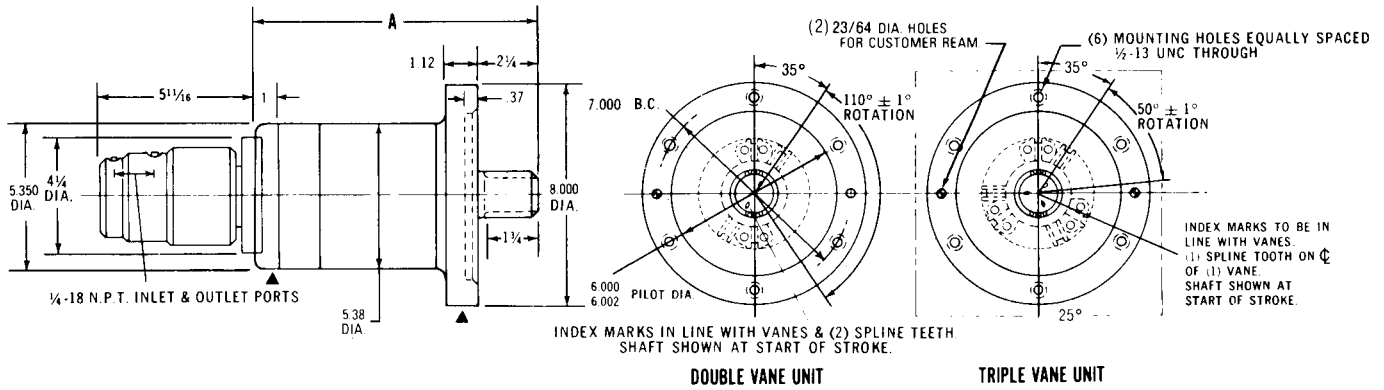

DOUBLE VANE UNIT

TRIPLE VANE UNIT

TEST PARAMETERS

Spline Data:

STD. S.A.E. External Flat Root.
Side Fit Involute Splines
Class 1 Fit Per S.A.E. J498b — 1969
26 Teeth — 20/40 Pitch — P.A. 30°
1.3360/1.3310 Major Dia.
1.3000 Pitch Dia. (Ref.)

NOTE: Uses 26R-2 Couplings
Ref. Couplings page 31

Model	Internal Size	Displacement Per Stroke	Displacement Per Radian	Rotation Of Vane	Est. Weight	A
SS-2V	3.75 x 2	8.64 cu. in.	4.50 cu. in.	110°	26.9 lb.	8 1/4
SS-3V	3.75 x 2	5.89 cu. in.	6.75 cu. in.	50°	27.1 lb.	8 1/4
SL-2V	3.75 x 4	17.28 cu. in.	9.00 cu. in.	110°	32.1 lb.	10 1/4
SL-3V	3.75 x 4	11.78 cu. in.	13.50 cu. in.	50°	32.5 lb.	10 1/4

Model	OIL				AIR					
	Break-Away in PSI	Leakage Cubic in. Per Min. at 1000 psi		Leakage Cubic cm. Per Min. at 1000 psi		Break-Away in PSI	Leakage Cubic ft. Per Min. at 100 psi		Leakage Cubic cm. Per Min. at 100 psi	
		2V	3V	2V	3V		2V	3V	2V	3V
SS	30	3.0	3.5	49.2	57.4	20	25	30	7080	8496
SL	30	3.2	3.7	52.5	60.6	20	25	30	7080	8496

ROTATING ACTUATORS MEDIUM

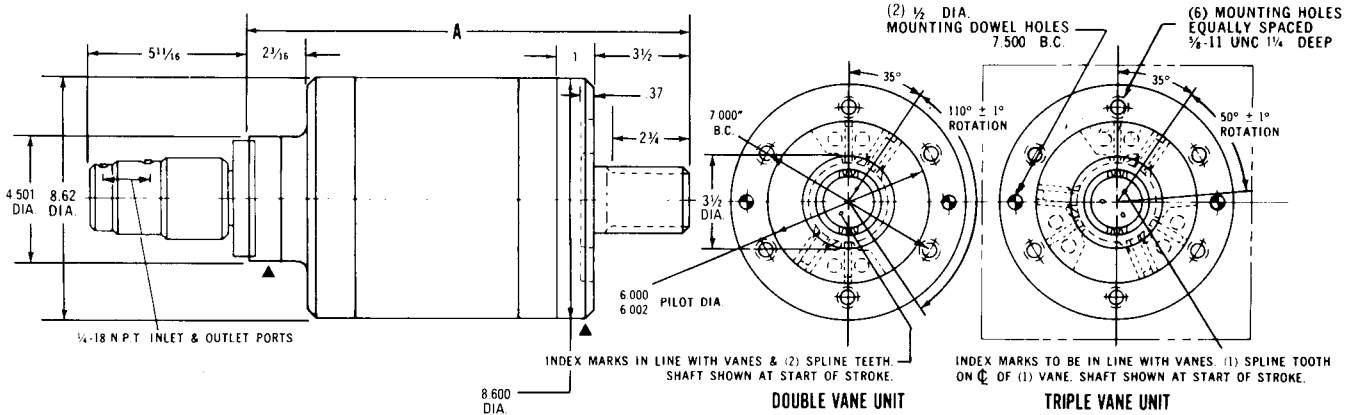

DOUBLE VANE UNIT

TRIPLE VANE UNIT

TEST PARAMETERS

Spline Data:

STD. S.A.E. External Flat Root.
Side Fit Involute Splines
Class 1 Fit Per S.A.E. J498b — 1969
26 Teeth — 12/24 Pitch — P.A. 30°
2.2293/2.2243 Major Dia.
2.1667 Pitch Dia. (Ref.)

NOTE: Uses 26R-10 Couplings
Ref. Couplings page 31

Model	Internal Size	Displacement Per Stroke	Displacement Per Radian	Rotation Of Vane	Est. Weight	A
MS-2V	6 x 3	38.9 cu. in.	20.26 cu. in.	110°	72 Lb	10 3/16
MS-3V	6 x 3	26.5 cu. in.	30.37 cu. in.	50°	76 Lb	10 3/16
ML-2V	6 x 6	77.8 cu. in.	40.53 cu. in.	110°	98 Lb	16 3/16
ML-3V	6 x 6	53 cu. in.	60.74 cu. in.	50°	104 Lb	16 3/16

Model	OIL				AIR					
	Break-Away in PSI	Leakage Cubic in. Per Min. at 1000 psi		Leakage Cubic cm. Per Min. at 1000 psi		Break-Away in PSI	Leakage Cubic ft. Per Min. at 100 psi		Leakage Cubic cm. Per Min. at 100 psi	
		2V	3V	2V	3V		2V	3V	2V	3V
MS	30	5.6	6.4	91.8	104.9	20	25	30	7080	8496
ML	30	5.8	6.6	95.1	108.2	20	30	35	8496	9912

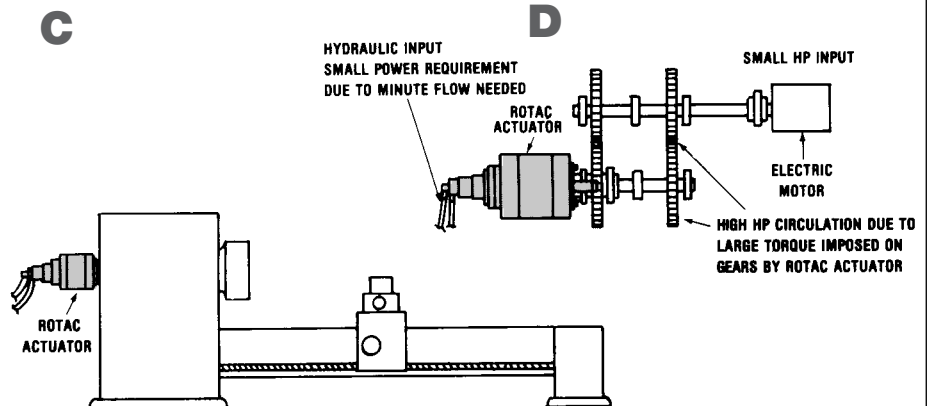
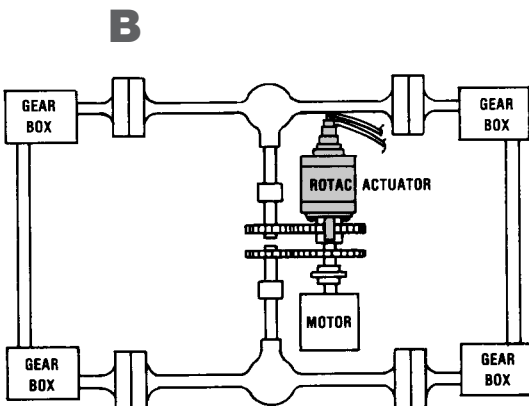

NOTE: See How to Order on page 25.

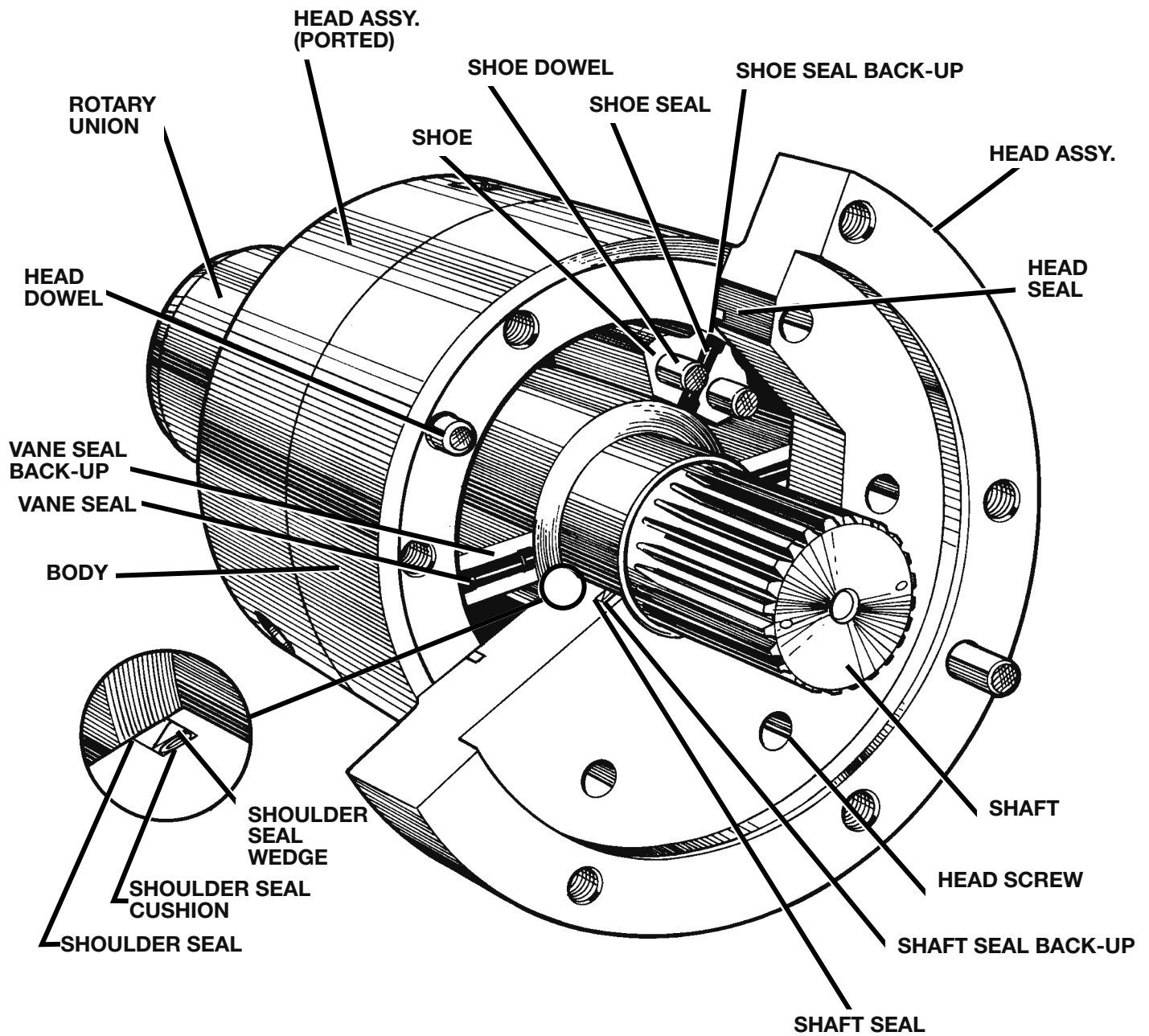

HOW TO ORDER

Sample: MS 2V SE IS END OIL

Model _____
 SS, SL, MS, ML

Number of Vanes _____
 2V—Double Vane
 3V—Triple Vane

Shaft Extension _____
 SE—Single Extension

_____ **Fluid Medium**
 Oil, Air, Other

_____ **Mounting**
 End, Flange, Special

_____ **Shaft Type**
 IS—30° Involute Spine
 Z—Special

If you require a special shaft extension, special mounting, or other special requirements, please enclose a drawing showing these requirements.



Micromatic

Options & Accessories

FOR ROTARY ACTUATORS

OPTIONS:

- Optional Threaded Porting
- Shaft End Potentiometer Shaft Holes
- Shaft End Tapped Holes
- Manifold Porting
- Keyway Data

ACCESSORIES:

- Cross Port Relief Manifolds
- Couplings

PROVIDING the “**MUSCLE**” for your lifting, turning, indexing, opening, closing, clamping, mixing, bending, testing, steering. . . **applications.**

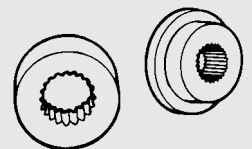
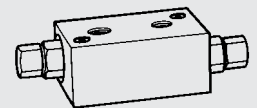
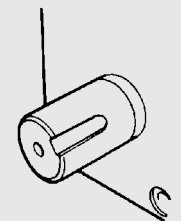
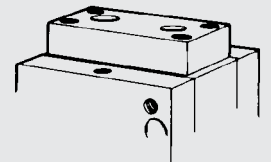
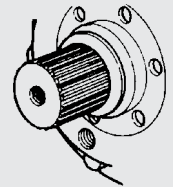
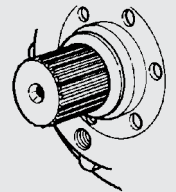
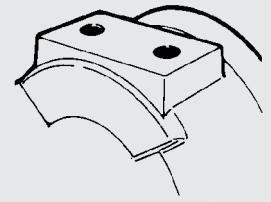

SPECIAL OPTIONS

OPTIONAL THREADED PORTING, SHAFT END POTENTIOMETER SHAFT HOLES, AND SHAFT END TAPPED HOLES

Model Description	National Pipe Thread (NPT)		BSPP		Potentiometer Shaft Hole	Shaft End Tapped Hole
	Size	Threads Per Inch	Size	Thread		

HS Series (Hollow Shaft)

HS—1½ HS—2½ HS—4	1/4	18	3/8	3/8-19 BSPP	N.A.	N.A.
HS—6 HS—10 HS—15	1/2	14	1/2	1/2-14 BSPP	N.A.	N.A.

SS Series (Solid Shaft)

SS—1	1/8	27	1/8	1/8-28 BSPP	$\frac{.2486}{.2491} \times .50$ DP	5/16-18 UNC x 1/2 DP
SS—4	1/4	18	1/4	1/4-19 BSPP	$\frac{.2486}{.2491} \times .50$ DP	3/8-16 UNC x 9/16 DP
SS—8 SS—12 HA—36	3/8	18	3/8	3/8-19 BSPP	$\frac{.2486}{.2491} \times .50$ DP	1/2-13 UNC x 3/4 DP
SS—25	1/2	14	1/2	1/2-14 BSPP	$\frac{.2486}{.2491} \times .50$ DP	3/4-10 UNC x 1-1/8 DP
SS—40	1	11-1/2	3/4	3/4-14 BSPP	$\frac{.2486}{.2491} \times .50$ DP	3/4-10 UNC x 1-1/8 DP
SS—65 SS—130	1	11-1/2	1	1-11 BSPP	$\frac{.2486}{.2491} \times .50$ DP	1-8 UNC x 1-1/2 DP*

SS Aluminum (Solid Shaft)

SS—0.2A SS—0.5A	N/A		N/A	N/A	.186-.187 x .38 DP	10-32 UNF-2B x .38 DP
	1/8	27	1/8	1/8-28 BSPP		
SS—1A	1/8	27	1/8	1/8-28 BSPP	$\frac{.2486}{.2491} \times .50$ DP	5/16-18 UNC x 1/2 DP
SS—4A	1/4	18	1/4	1/4-19 BSPP	$\frac{.2486}{.2491} \times .50$ DP	3/8-16 UNC x 9/16 DP
SS—8A	3/8	18	3/8	3/8-19 BSPP	$\frac{.2486}{.2491} \times .50$ DP	1/2-13 UNC x 3/4 DP

* 1/2-13 UNC x 1 DP tapped holes provided as standard for lifting.

MP Series (Solid Shaft)

MP—11	1/8	27	CONSULT FACTORY			
MP—22	1/4	18				
MP—32	3/8	18				
MP—34	3/8	18				
MP—63	3/4	14				
MP—84	3/4	14				
MP—105	1	11-1/2				
MP—116 MP—128	1-1/4	11-1/2				

OPTIONAL SPLINE DATA FOR HOLLOW SHAFT SERIES

HS Series (Hollow Shaft)

New Model Description	Pitch	Teeth	Pressure Angle	Major Dia.	Minor Dia.	Pitch Dia.	Length	Spline Std.
HS—1½ HS—2½ HS—4	16/32	24	30°	$\frac{1.5735}{1.5625}$	$\frac{1.4375}{1.4425}$	1.5000	1.75	ASA B5.15-1960
HS—6 HS—10 HS—15	12/24	26	30°	$\frac{2.2630}{2.2500}$	$\frac{2.0833}{2.0883}$	2.1667	2.00	ASA B5.15-1960

NOTE: Models HS-1½, 2½, and 4 have index mark at 6 o'clock.
Models HS-6, -10 and -15 have index mark at 6 o'clock

Options & Accessories

SPECIAL OPTIONS (CONTINUED)

MANIFOLD PORTING

Hollow Shaft Series

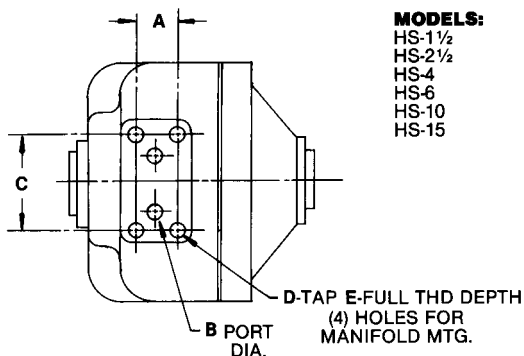

Solid Shaft Series

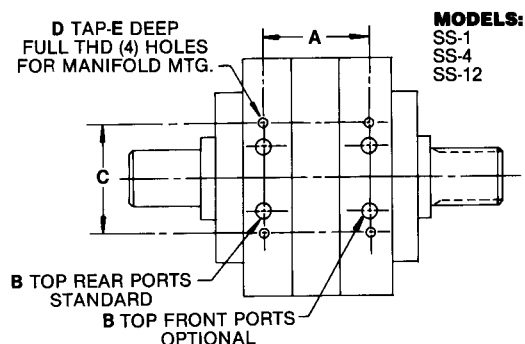

Solid Shaft Series

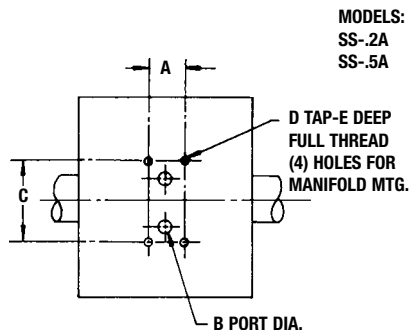

Solid Shaft Series

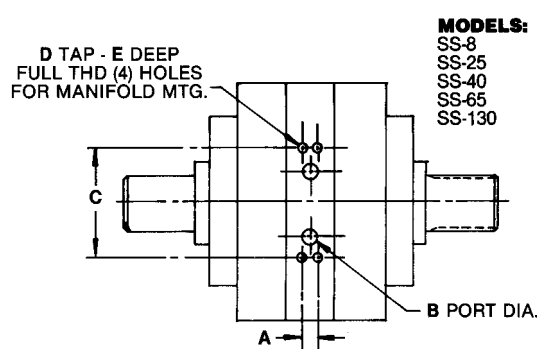

NOTE: Port locations are symmetrical to manifold mtg. holes.
NOTE: See actuator catalog pages for port location and spacing.

Model Description	A	B	C	D	E
-------------------	---	---	---	---	---

HS Series (Hollow Shaft)

HS-1½ HS-2½ HS-4	1.000	1/4	2-3/4"	14-20 UNC	1/2"
HS-6	1.375	7/16	3-3/8"	3/8-16 UNC	3/4"
HS-10 HS-15	1.750	7/16	4"	1/2-13 UNC	1"

SS Series (Solid Shaft)

SS-0.2A	1.086	1/8	1-5/8"	#8-32 UNC	1/4"
SS-0.5A	1.250	5/32	1-3/4"	#10-32 UNF	3/8"
SS-1	1.848	5/32	2"	1/4-20 UNC	3/8"
SS-4	3.000	1/4	3"	1/4-20 UNC	1/2"
SS-8	1.125	1/2	3-1/4"	5/16-18 UNC	11/16"
SS-12	4.000	5/16	4"	3/8-16 UNC	5/8"
SS-25	1.875	11/16	4-7/8"	1/2-13 UNC	1-1/8"
SS-40	2.000	7/8	6"	1/2-13 UNC	1"
SS-65	3.000	1-5/32	6-1/2"	5/8-11 UNC	1"
SS-130	2.750	1-5/32	8-1/4"	5/8-11 UNC	1"

SPECIAL OPTIONS (CONTINUED)

OPTIONAL SHAFT KEYWAY DATA

Keyway Drives are recommended only for low pressure and low cycle applications.
Note the maximum recommended torque for each model in the table below.

Max. recommended torque values are based on using a key with a min. yield strength of 65,000 psi and operating the unit within normal accepted application guidelines.

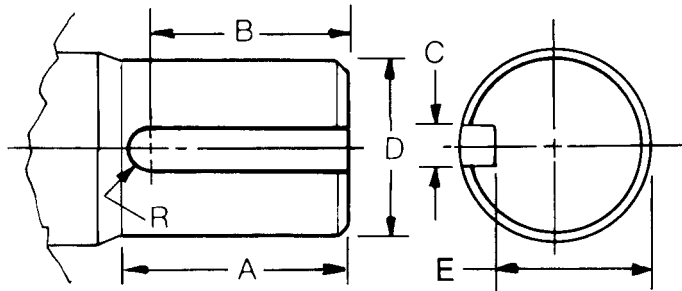

SS SERIES:

STANDARD KEYWAY IS
LOCATED AT 12 O'CLOCK, 6
O'CLOCK ON MODELS .2A & .5A
WHEN WINGSHAFT IS AT MID-
POSITION OF TRAVEL

Model Description	Shaft Ext. (A)	Keyway Length (B) ± .02	Keyway Width (C) + .0005 - .0015	Shaft Dia. (D)	Keyway Depth (E)	Max.* Recommended Torque (in. lb) (One Key)	Max. Supply Pressure
SS Series (Solid Shaft)							
SS-1-1V SS-1-2V	1.07	.750	.250	1.0360 1.0350	.905 .910	1,620	1,350 (1V) 675 (2V)
SS-4-1V SS-4-2V	1.83	1.250	.375	1.5460 1.5445	1.353 1.358	6,040	1,585 (1V) 793 (2V)
SS-8-1V	2.28	1.875	.500	1.9370 1.9355	1.681 1.686	15,140	1,892 (1V)
SS-12-1V SS-12-2V	2.63	2.000	.500	2.1970 2.1955	1.941 1.946	18,320	1,472 (1V) 736 (2V)
SS-25-1V	4.11	3.250	.750	3.000 2.998	2.625 2.620	60,975	2,448 (1V)
HA-36-1V	3.86	3.250	.750	2.8460 2.8410	2.461 2.471	57,780	1,605 (1V)
SS-40-1V SS-40-2V	4.11	3.250	.750	3.3460 3.3430	2.963 2.968	67,990	1,700 (1V) 850 (2V)
SS-65-1V SS-65-2V	4.54	3.875	1.000	3.846 3.841	3.341 3.345	124,190	1,910 (1V) 955 (2V)
SS-130-1V SS-130-2V	6.66	5.500	1.250	5.2960 5.2920	4.667 4.662	303,520	2,335 (1V) 1,167 (2V)
SS Aluminum (Solid Shaft)							
SS-0.2A-1V	1.11	.750	.1240 .1253	.594/.593	.530 .525	460	2,305 (1V)
SS-0.5A-1V SS-0.5A-2V	1.46	.700	.1875	.715/.714	.616/.621	780	1,738 (1V) 868 (2V)
SS-1A-1V SS-1A-2V	1.07	.750	.250	1.0360 1.0350	.905 .910	1,620	1,350 (1V) 675 (2V)
SS-4A-1V SS-4A-2V	1.83	1.250	.375	1.5460 1.5445	1.353 1.358	6,040	1,585 (1V) 793 (2V)
SS-8A-1V	2.28	1.875	.500	1.9370 1.9355	1.681 1.686	15,140	1,892 (1V)

*NOTE: For double key use (1.75) times this value up to full torque capacity of actuator.

ACCESSORIES

CROSS-PORT RELIEF MANIFOLD DATA

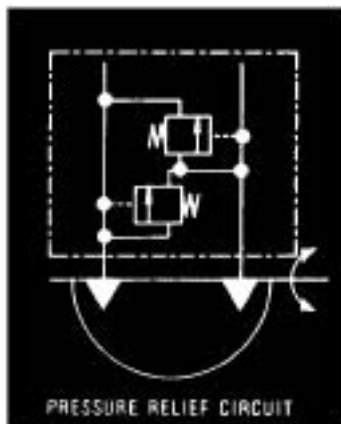

SPECIFICATIONS
 TYPE — PISTON DIFFERENTIAL
 CAPACITY — 40 G.P.M.
 PRESSURE RANGE —
 COMPATIBLE WITH
 MODEL MP
 FACTORY SET AT 50 P.S.I.
 ABOVE MAX.
 PRESSURE RATING

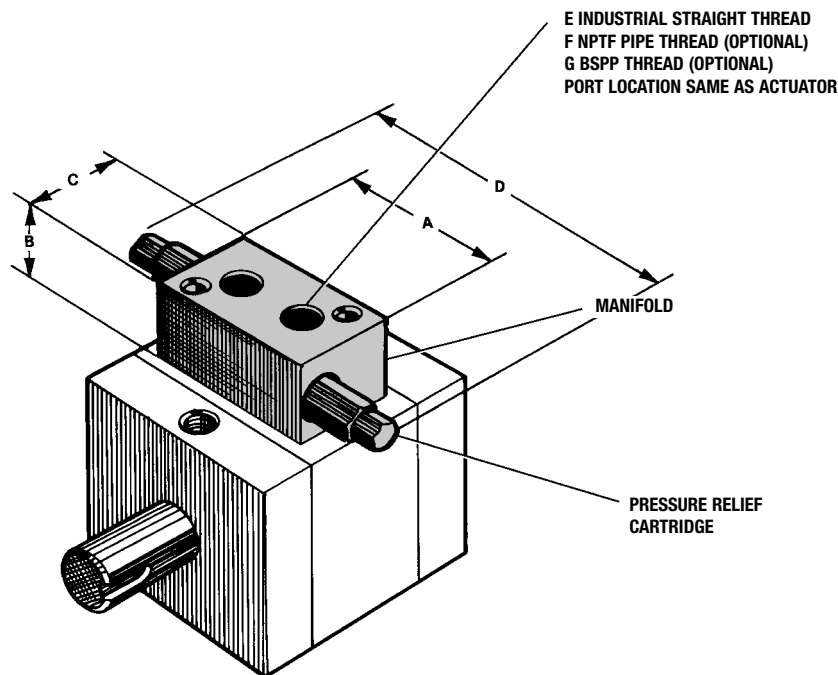

Model	Ass'y No. St. Thd.	Opt. Ass'y No. Pipe Thd.	A	B	C	D	E (2)* St. Thd.	F (1)* NPTF	G (0)* BSPP
SS-1	401498-00*	—	3.00	2.50	4.00	7.62	$\frac{7}{16}$ -20	$\frac{1}{8}$ -27	$\frac{1}{8}$ -28
SS-4	411552-00*	—	4.00	2.50	4.25	8.25	$\frac{9}{16}$ -18	$\frac{1}{4}$ -18	$\frac{3}{8}$ -19
SS-8	416061-00*	—	4.25	2.50	4.87	8.75	$\frac{9}{16}$ -18	$\frac{3}{8}$ -18	$\frac{3}{8}$ -19
SS-12	421669-00*	—	5.00	3.00	5.38	9.00	$\frac{3}{4}$ -16	$\frac{3}{8}$ -18	$\frac{3}{8}$ -19
SS-25	452451-00*	—	6.38	2.50	6.25	10.05	$\frac{7}{8}$ -14	$\frac{1}{2}$ -14	$\frac{1}{2}$ -14
SS-40	431491-00*	—	7.38	2.50	6.25	11.00	$1\frac{5}{16}$ -12	1-11 $\frac{1}{2}$	$\frac{3}{4}$ -14
SS-65	436046-00*	—	8.50	2.50	5.00	10.75	$1\frac{5}{16}$ -12	1-11 $\frac{1}{2}$	1-11
SS-130	441238-00*	—	10.25	2.50	5.00	12.00	$1\frac{5}{8}$ -12	1-11 $\frac{1}{2}$	1-11
HS-1.5, 2.5, 4.0	511040-00*	—	3.75	2.50	2.50	8.25	$\frac{9}{16}$ -18	$\frac{1}{4}$ -18	$\frac{3}{8}$ -19
HS-6.0	452458-00*	—	4.50	2.50	3.50	9.50	$\frac{3}{4}$ -16	$\frac{1}{2}$ -14	$\frac{1}{2}$ -14
HS-10.0, 15.0	452456-00*	—	5.50	2.50	3.00	9.38	$\frac{3}{4}$ -16	$\frac{1}{2}$ -14	$\frac{1}{2}$ -14
MP-32, 34	26-11-218	26-11-200	4.00	2.50	2.50	8.38	$\frac{7}{8}$ -14	$\frac{1}{2}$ -14	—
MP-63	26-11-219	26-11-201	5.00	2.50	3.00	9.05	$1\frac{1}{16}$ -12	$\frac{3}{4}$ -14	—
MP-84	26-11-220	26-11-202	6.00	2.50	4.00	9.75	$1\frac{5}{16}$ -12	1-11 $\frac{1}{2}$	—
MP-105	26-11-221	26-11-203	7.00	2.50	4.00	10.44	$1\frac{5}{8}$ -12	$1\frac{1}{4}$ -11 $\frac{1}{2}$	—
MP-116 & 128	26-11-222	26-11-205	8.00	2.50	5.00	11.56	$1\frac{7}{8}$ -12	$1\frac{1}{2}$ -11 $\frac{1}{2}$	—

All Dimensions in Inches

ACCESSORIES (CONTINUED)

COUPLINGS (See actuator model sections for SAE, ASA spline specifications.)

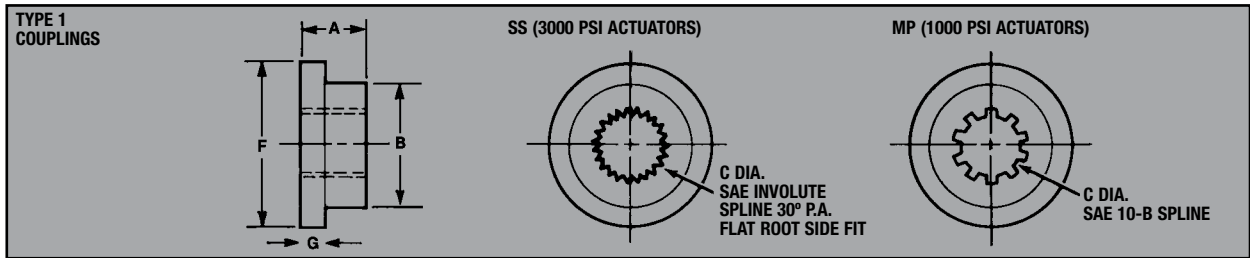

	Part No.	Model	A	B	C	F	G
For "SS" Models	451498-001	SS-1	1.00	1.75	20T-20/40P-1.0000P.D.	3.50	0.50
	451498-002	SS-4	1.50	2.50	24T-16/32P-1.5000P.D.	5.25	0.62
	451498-008	SS-8	2.00	3.00	30T-16/32P-1.8750P.D.	6.00	0.75
	451498-003	SS-12	2.25	3.50	26T-12/24P-2.1667P.D.	7.00	0.75
	451498-004	SS-40	3.50	5.00	26T-8/16P-3.2500P.D.	10.50	1.00
	451498-006	SS-65	3.88	6.00	30T-8/16P-3.7500P.D.	12.00	1.38
	451498-005	SS-130	5.50	8.00	31T-6/12P-5.1667P.D.	16.00	1.38
For "MP" Models	26-11-241	MP-11	0.50	0.88	* 19T-40/80P-0.4570P.D.	2.00	0.25
	26-11-240	MP-22	0.75	1.12	* 29T-40/80P-0.7250P.D.	2.25	0.31
	26-11-176	MP-32	1.63	2.31	1.25	3.75	0.50
		MP-34					
	26-11-177	MP-63	1.75	3.63	2.00	5.25	0.63
	26-11-178	MP-84	2.13	4.13	2.50	6.00	0.75
	26-11-179	MP-105	2.50	5.25	3.00	7.25	0.88
	26-11-180	MP-116	3.00	6.25	3.50	8.50	1.00
	26-11-181	MP-128	4.25	7.25	4.00	10.00	1.25
For "26R" Models	26-11-5034	26R-2	1.63	2.31	26T-20/40P-1.3000P.D.	3.75	0.50
	26-11-5035	26R-5	1.75	3.63	26T-16/32P-1.6250P.D.	5.25	0.63
	26-11-5036	26R-10	2.13	4.13	26T-12/24P-2.1667P.D.	6.00	0.75
	26-11-5037	26R-17	2.50	5.25	26T-10/20P-2.6000P.D.	7.25	0.88
	26-11-5038	26R-31	3.00	6.25	32T-10/20P-3.2000P.D.	8.50	1.00
	26-11-5039	26R-62	4.25	7.25	32T-8/16P-4.0000P.D.	10.00	1.25
	26-11-5040	26R-124	5.25	8.75	38T-8/16P-4.7500P.D.	12.25	1.75

*Involute Serration

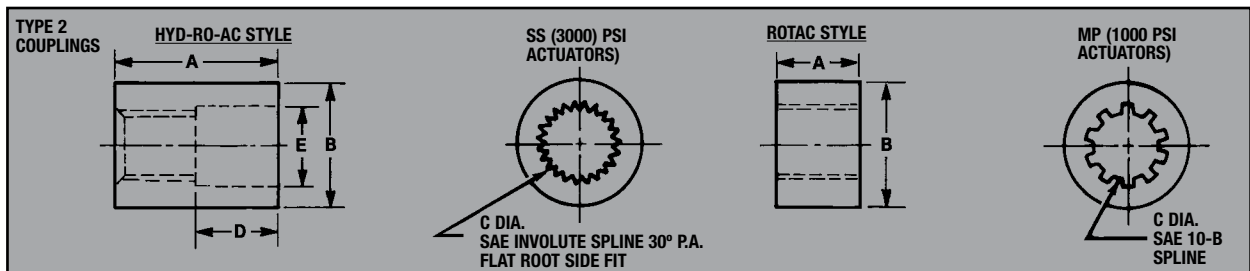

	Part No.	Model	A	B	C	D	E
For "SS" Models	451497-010	SS-2A	1.75	1.00	18T-32/64P-0.5625P.D.	0.88	0.626
	451497-009	SS-5A	2.00	1.25	22T-32/64P-0.6875P.D.	1.00	0.751
	451497-001	SS-1	2.00	1.75	20T-20/40P-1.0000P.D.	1.00	1.126
	451497-002	SS-4	3.00	2.50	24T-16/32P-1.5000P.D.	1.50	1.751
	451497-008	SS-8	4.00	3.00	30T-16/32P-1.8750P.D.	2.00	2.126
	451497-003	SS-12	4.50	3.50	26T-12/24P-2.1667P.D.	2.25	2.501
	451497-004	SS-40	6.00	5.00	26T-8/16P-3.2500P.D.	3.50	3.751
	451497-006	SS-65	8.00	6.00	30T-8/16P-3.7500P.D.	3.88	4.376
	451497-005	SS-130	10.00	8.00	31T-6/12P-5.1667P.D.	5.50	6.001
For "MP" Models	26-11-182	MP-32	1.63	2.00	1.25	—	—
		MP-34					
	26-11-183	MP-63	2.13	3.25	2.00	—	—
	26-11-184	MP-84	2.50	3.75	2.50	—	—
	26-11-185	MP-105	3.00	4.75	3.00	—	—
	26-11-186	MP-116	4.25	5.75	3.50	—	—
	26-11-187	MP-128	4.25	5.75	4.00	—	—
For "26R" Models	26-11-5041	26R-2	1.63	2.00	26T-20/40P-1.3000P.D.	—	—
	26-11-5042	26R-5	1.75	2.75	26T-16/32P-1.6250P.D.	—	—
	26-11-5043	26R-10	2.13	3.25	26T-12/24P-2.1667P.D.	—	—
	26-11-5044	26R-17	2.50	3.75	26T-10/20P-2.6000P.D.	—	—
	26-11-5045	26R-31	3.00	4.75	32T-10/20P-3.2000P.D.	—	—
	26-11-5046	26R-62	4.25	5.75	32T-8/16P-4.0000P.D.	—	—
	26-11-5047	26R-124	5.25	7.00	38T-8/16P-4.7500P.D.	—	—



Micromatic

525 Berne Street
Berne, IN 46711

Welcome to *MICROMATIC*

Welcome to the world of rotary motion. We appreciate your interest and are pleased to offer you our catalog, featuring Micromatic's extensive line of rotary actuators. Micromatic actuators have earned worldwide renown under the trade names of Rotac[®] and Hyd-ro-ac[™]. Micromatic, long recognized as an industry leader, has been designing and manufacturing rotary actuators for over forty years.

Micromatic provides actuators with either hydraulic or pneumatic capability. Your imagination alone limits the number of possible applications.

We offer true "A to Z" capability. Our standard units produce up to 700,000 in. lbs. of torque @ 3000 PSI, and we have designed "specials" with 4,500,000 in. lbs. @ 2200 PSI capability.

If your application requires an actuator outside the range of our standard line, our seasoned product design and application engineering group will modify and/or design a specialty actuator to suit your needs.

Contents

LP Models up to 150 psi, pneumatic	2-5
MP Models up to 1,000 psi, medium pressure	6-9
26R Models up to 3,000 psi, high pressure	10-13
SS Models up to 3,000 psi, high pressure, solid shaft	14-17
HS Models up to 3,000 psi, high pressure, hollow shaft	18-21
Rotating Actuators	22-25
Options and Accessories	26-31

For the latest information
please visit us online at
www.micromaticllc.com



Micromatic

ph 800.333.5752 | 260.589.2136