

# INSTRUCTION MANUAL FOR



## RUGER® PC CARBINE™



– Rugged, Reliable Firearms® –



**READ THE INSTRUCTIONS AND  
WARNINGS IN THIS MANUAL CAREFULLY  
BEFORE USING THIS FIREARM**

© 2018 Sturm, Ruger & Co., Inc.

This manual may not be reproduced in whole or in part without the express written permission of Sturm, Ruger & Co., Inc.

**For Service on This Model Please Call:  
(336) 949-5200 (See p. 41)**

THIS INSTRUCTION MANUAL SHOULD ALWAYS ACCOMPANY THIS FIREARM AND BE TRANSFERRED WITH IT UPON CHANGE OF OWNERSHIP, OR WHEN THE FIREARM IS LOANED OR PRESENTED TO ANOTHER PERSON

[WWW.RUGER.COM](http://WWW.RUGER.COM)

## State-By-State Warnings

Certain states require by law that their own specified warning notices in larger-than-normal type be conspicuously included by the manufacturer, distributor or retailer with firearms sold in that state. Sturm, Ruger & Co., Inc. sells its products in compliance with applicable laws and regulations. Because our products may be sold in these states, we include the following:

### California:

#### **WARNING**

“Firearms must be handled responsibly and securely stored to prevent access by children and other unauthorized users. California has strict laws pertaining to firearms, and you may be fined or imprisoned if you fail to comply with them. Visit the Web site of the California Attorney General at <https://oag.ca.gov/firearms> for information on firearm laws applicable to you and how you can comply.

Prevent child access by always keeping guns locked away and unloaded when not in use. If you keep a loaded firearm where a child obtains and improperly uses it, you may be fined or sent to prison.”

#### **ADVERTENCIA**

“Las armas de fuego deben manipularse de manera responsable y segura para evitar el acceso de niños y otros usuarios no autorizados. California tiene leyes estrictas relacionadas con armas de fuego, y usted puede ser multado o encarcelado si no las cumple. Visite el sitio web del Procurador General de California en <https://oag.ca.gov/firearms> para obtener información sobre las leyes de armas de fuego que le son aplicables y cómo puede cumplirlas.

A los niños los atraen las armas de fuego y las pueden hacer funcionar. Ellos pueden causarse lesiones graves y la muerte. Evite que los niños tengan acceso a las armas de fuego guardándolas siempre con llave y descargadas cuando no las esté utilizando. Si usted tiene un arma de fuego cargada en un lugar en que un niño tiene acceso a ella y la usa indebidamente, le pueden dar una multa o enviarlo a la cárcel.”

### **Connecticut:**

“UNLAWFUL STORAGE OF A LOADED FIREARM MAY RESULT IN IMPRISONMENT OR FINE.”

### **Florida:**

“IT IS UNLAWFUL, AND PUNISHABLE BY IMPRISONMENT AND FINE, FOR ANY ADULT TO STORE OR LEAVE A FIREARM IN ANY PLACE WITHIN THE REACH OR EASY ACCESS OF A MINOR UNDER 18 YEARS OF AGE OR TO KNOWINGLY SELL OR OTHERWISE TRANSFER OWNERSHIP OR POSSESSION OF A FIREARM TO A MINOR OR A PERSON OF UNSOUND MIND.”

### **Maine:**

“ENDANGERING THE WELFARE OF A CHILD IS A CRIME. IF YOU LEAVE A FIREARM AND AMMUNITION WITHIN EASY ACCESS OF A CHILD, YOU MAY BE SUBJECT TO FINE, IMPRISONMENT OR BOTH. KEEP FIREARMS AND AMMUNITION SEPARATE. KEEP FIREARMS AND AMMUNITION LOCKED UP. USE TRIGGER LOCKS.”

### **Maryland:**

“WARNING: Children can operate firearms which may cause death or serious injury. It is a crime to store or leave a loaded firearm in any location where an individual knew or should have known that an unsupervised minor would gain access to the firearm. Store your firearm responsibly!”

## **Massachusetts:**

“WARNING FROM THE MASSACHUSETTS ATTORNEY GENERAL: This handgun is not equipped with a device that fully blocks use by unauthorized users. More than 200,000 firearms like this one are stolen from their owners every year in the United States. In addition, there are more than a thousand suicides each year by younger children and teenagers who get access to firearms. Hundreds more die from accidental discharge. It is likely that many more children sustain serious wounds, or inflict such wounds accidentally on others. In order to limit the chance of such misuse, it is imperative that you keep this weapon locked in a secure place and take other steps necessary to limit the possibility of theft or accident. Failure to take reasonable preventive steps may result in innocent lives being lost, and in some circumstances may result in your liability for these deaths.”

“IT IS UNLAWFUL TO STORE OR KEEP A FIREARM, RIFLE, SHOTGUN OR MACHINE GUN IN ANY PLACE UNLESS THAT WEAPON IS EQUIPPED WITH A TAMPER-RESISTANT SAFETY DEVICE OR IS STORED OR KEPT IN A SECURELY LOCKED CONTAINER.”

## **New Jersey:**

“IT IS A CRIMINAL OFFENSE TO LEAVE A LOADED FIREARM WITHIN EASY ACCESS OF A MINOR.”

## **New York City:**

“THE USE OF A LOCKING DEVICE OR SAFETY LOCK IS ONLY ONE ASPECT OF RESPONSIBLE FIREARM STORAGE. FOR INCREASED SAFETY, FIREARMS SHOULD BE STORED UNLOADED AND LOCKED IN A LOCATION THAT IS BOTH SEPARATE FROM THEIR AMMUNITION AND INACCESSIBLE TO CHILDREN AND UNAUTHORIZED PERSONS.”

**North Carolina:**

“IT IS UNLAWFUL TO STORE OR LEAVE A FIREARM THAT CAN BE DISCHARGED IN A MANNER THAT A REASONABLE PERSON SHOULD KNOW IS ACCESSIBLE TO A MINOR.”

**Texas:**

“IT IS UNLAWFUL TO STORE, TRANSPORT, OR ABANDON AN UNSECURED FIREARM IN A PLACE WHERE CHILDREN ARE LIKELY TO BE AND CAN OBTAIN ACCESS TO THE FIREARM.”

**Wisconsin:**

“IF YOU LEAVE A LOADED FIREARM WITHIN THE REACH OR EASY ACCESS OF A CHILD YOU MAY BE FINED OR IMPRISONED OR BOTH IF THE CHILD IMPROPERLY DISCHARGES, POSSESSES, OR EXHIBITS THE FIREARM.”

\* \* \* \* \*

Please check with your licensed retailer or state police for additional warnings which may be required by local law or regulation. Such regulations change constantly, and local authorities are in the best position to advise you on such legal matters.

**FIREARMS SAFETY IS YOUR RESPONSIBILITY**  
**SAFETY MUST BE THE FIRST AND CONSTANT**  
**CONSIDERATION OF EVERY PERSON WHO HANDLES**  
**FIREARMS AND AMMUNITION.**

This Instruction Manual is designed to assist you in learning how to use and care for your **RUGER® PC CARBINE™** rifle properly. Please contact us if you have any questions.

Only when you are certain you fully understand the manual and can properly carry out its instructions should you practice loading, unloading, etc. with live ammunition. If you have any doubts about your ability to handle or use a particular type of gun safely, you should seek supervised instruction. Such personalized instruction often is available from local gun retailers, gun clubs or police departments. If none of these sources can help visit [www.nra.org](http://www.nra.org) or write to the following address:

National Rifle Association  
11250 Waples Mill Road  
Fairfax, VA 22030-7400

The person possessing a gun has a full-time job. You cannot guess; You cannot forget; You must know how to use your firearm safely. **Do not use any firearm without having a complete understanding of its particular characteristics and safe use.** Remember: There is no such thing as a foolproof gun.

# TABLE OF CONTENTS

	<b>Page</b>
State-By-State Warnings .....	2
Nomenclature .....	8
Locking Device Installation Instructions .....	9
General Information .....	11
The Bolt Stop .....	12
Magazine Well Removal & Replacement .....	13
Ambidextrous Magazine Release .....	16
Ambidextrous Charging Handle .....	17
Sight Adjustment .....	18
Thread Protector .....	19
Length of Pull Adjustment .....	19
Operation of Safety .....	20
Ammunition .....	21
Magazines .....	22
Loading the Magazine .....	22
To Load and Fire (With Magazine) .....	22
To Load and Fire (Without Magazine) .....	25
To Unload .....	25
To Extract and Eject a Chambered Cartridge .....	27
To Clear a Malfunction (“Jam”) .....	27
To Minimize Malfunctions (“Jams”) .....	28
To Disassemble .....	30
Reassembly .....	34
Barrel/Forend Assembly .....	37
Magazine Inspection and Care .....	38
Care and Cleaning .....	39
Storage .....	40
Service and Parts Policy .....	41
Shipping Firearms for Repair .....	41
Ordering Parts .....	42
Parts Lists .....	43
Exploded Views .....	45 - 49
<b>The Basic Rules of Safe Firearms Handling .....</b>	<b>50</b>
Warranty Information .....	56

“RUGER” is a registered U.S. trademark.



## **WARNINGS OF GREAT IMPORTANCE ARE FOUND ON THE FOLLOWING PAGES:**

Locking Devices	9	Unloading	25
Alterations	11	Malfunctions	29
Manual Safety	20	Disassembly	29
Ammunition	21	Lubrication	39
Lead Exposure	21	Storage	40
Firing	23	Shipping	41
Handling	24	Parts Purchasers	42

**OTHER CAUTIONS AND WARNINGS APPEAR THROUGHOUT THE MANUAL.**

# NOMENCLATURE

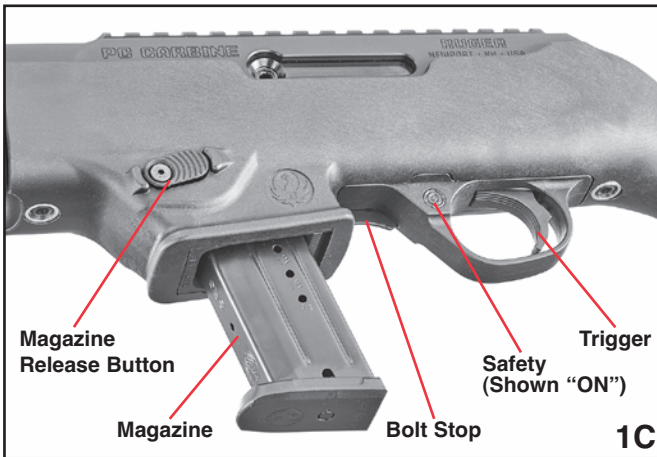
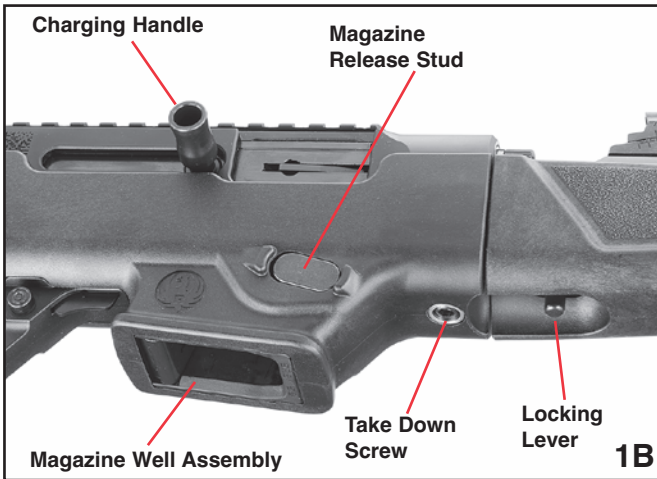
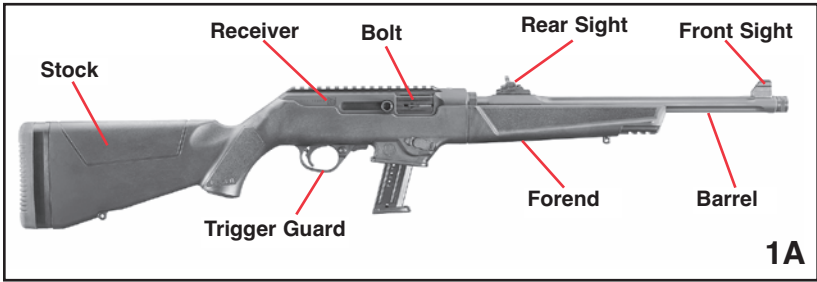

**Figures 1A, B, C.** In these illustrations the frequently used operating components are identified. Note that the safety is fully depressed into the left side of the trigger guard (and fully protruding from the right side, which is not visible) and is therefore in its "ON" (safe) position.



# LOCKING DEVICE INSTALLATION INSTRUCTIONS



## WARNING – USE OF LOCKING DEVICES



**Do not store keys  
in lock.**

- Always keep your firearm pointed in a safe direction, including when you are installing or removing your locking device.
- Always verify that your firearm is completely **unloaded** before installing your locking device.
- Do **not** install locking devices in the trigger guard; always keep your fingers and locking device outside the trigger guard during device installation and removal.
- Store firearms, ammunition and keys separately and securely, away from children and careless adults; do **not** store your firearm with the keys in the locking device.
- Do not attempt to work the action of your firearm with the locking device in place; this may damage your firearm.
- While locking devices are an important aid to security measures, they are not a substitute for safe firearm handling and proper storage. Remember that any mechanical device can be bypassed with enough time, knowledge, determination and equipment.

**LOCKING DEVICES MUST BE  
USED SAFELY AND  
RESPONSIBLY**

It is important to use the locking device on your Ruger® firearm when the firearm is stored or immediate use is not planned.

Keep the muzzle pointed in a safe direction and your fingers outside the trigger guard at all times!

1. Remove the magazine. Be sure the firearm and its magazine are completely unloaded and contain no cartridges or cartridge cases!
2. Open the action completely. Use the bolt stop to keep the action open.
3. Remove the barrel/forend assembly as described in the section “To Disassemble,” p. 30.
4. Insert the cable directly into your rifle as shown in Figure 2.
5. To lock: With the key turned to the farthest clockwise position, insert the loose end of the cable into the lock. Turn the key counterclockwise and remove the key.
6. Once the lock is securely closed, pull firmly on the lock to test the connection and be sure it is locked. **Do not leave or store your firearm with the key in the lock!** Store your locked unloaded firearm and the key in secure, separate locations, away from ammunition, children, and unauthorized adults.

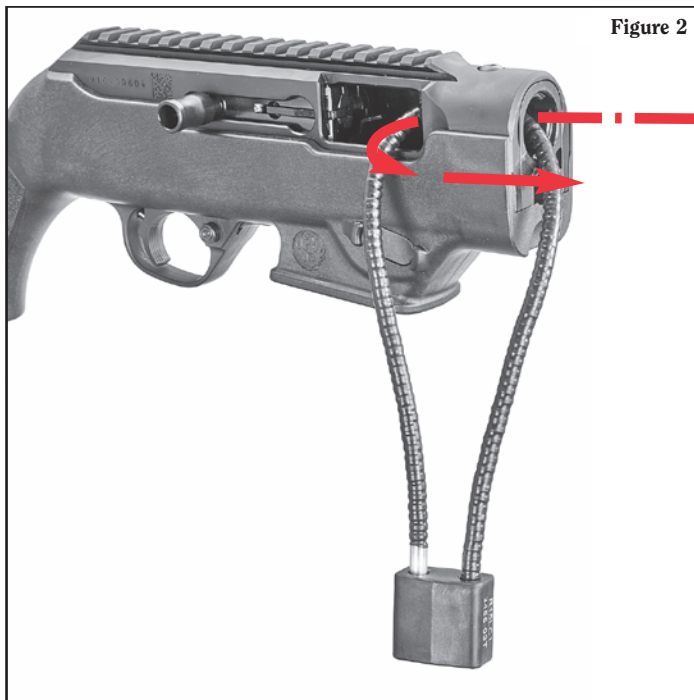

*Correct Installation of Cable Lock  
For RUGER® PC CARBINE™ Rifle*

**FIREARMS ARE DANGEROUS WEAPONS**  
**READ THE INSTRUCTIONS AND WARNINGS IN THIS**  
**MANUAL THOROUGHLY AND CAREFULLY BEFORE USING.**

	<b>WARNING-ALTERATIONS</b>
	This product was designed to function properly in its original condition. Alterations can make it unsafe. Do not alter any part or add or substitute parts or accessories not made by Sturm, Ruger & Co., Inc.
<b>DO NOT ALTER ANY GUN</b>	

## **GENERAL INFORMATION AND MECHANICAL CHARACTERISTICS**

The **RUGER® PC CARBINE™** is an autoloading rifle chambered for the 9mm Luger (Parabellum) cartridge. Use only ammunition of the correct caliber. The **PC CARBINE™** is “blowback” operated and uses standard **RUGER® SRS®** pistol magazines. Retracting the charging handle cocks the internal hammer and compresses the recoil spring. When the bolt is manually released, it moves forward (driven by the recoil spring), strips a cartridge from the magazine (if a loaded magazine is in place) and chambers the cartridge. The bolt is held against the chambered cartridge by the recoil spring.

When the trigger is pulled, the hammer is released and strikes the firing pin. The firing pin indents the cartridge primer and ignites the priming compound. This ignites the powder in the cartridge case and a great volume of gas is instantly generated, which acts on the interior of the cartridge case in all directions.

Because the bullet offers the least resistance, it moves out of the cartridge case and exits the muzzle. The bolt then moves rearward automatically, extracting and ejecting the fired cartridge case, and at the same time cocking the hammer and compressing the recoil spring, etc., as described above. Once the trigger is released, the rifle is ready to fire again.

Each time the trigger is pulled and released, the same cycle is repeated until there are no more cartridges in the magazine or in the chamber.

	<b>WARNING – RIFLE MAY FIRE WITH MAGAZINE REMOVED</b>
The rifle will fire if there is a cartridge in the chamber and the trigger is pulled, whether or not there is a magazine in place! Removing the magazine does not unload the rifle. Never assume the rifle is unloaded. Visually inspect the chamber and the magazine each time the rifle is handled to be certain there are no cartridges in either.	

The **RUGER® PC CARBINE™** features an easy takedown for quick separation of the barrel/forend assembly from the action for ease of transportation and storage. Simple reassembly allows for a secure connection of the barrel/forend assembly and action and returns the firearm to zero, even when receiver mounted optics are used, ensuring consistent accuracy. See page 37 for information about the “Barrel/Forend Assembly.”

## THE BOLT STOP

The bolt stop is located in the forward section of the trigger guard (see Figure 1C, p. 8). The bolt stop is the manually operated means of retaining the bolt in the rearward (open) position. When the bolt is locked open, the rifle is in an inoperative safe condition for inspection of the chamber, cleaning, etc.

**To hold the bolt open:** Retract the charging handle to its extreme rearward position and, while holding it there, press up on the bolt stop. Release pressure on the charging handle and it will move forward a fraction of an inch and then be held in its open position by the bolt stop (see Figure 3a).



### WARNING – JARRING RIFLE CAN RELEASE BOLT AND CHAMBER A ROUND

The bolt stop is **NOT** a safety device. It should not be used to hold the bolt back when there are cartridges in the magazine. A slight jar to the butt end of the rifle **CAN** cause the bolt stop to disengage and to feed a cartridge into the chamber. The bolt stop should only be relied upon to hold the bolt in its rearward position when the chamber is empty and an empty magazine is in place. The bolt stop is there for convenience when changing magazines and to hold the bolt in its rearward position when the rifle is unloaded for cleaning or inspection.

**NOTE:** The **RUGER® PC CARBINE™** also has an automatic last round hold open. Once the last round of a magazine is extracted and ejected, the follower of the magazine engages the last round hold open. The last round hold open will hold the bolt in an open position after the last round is fired.

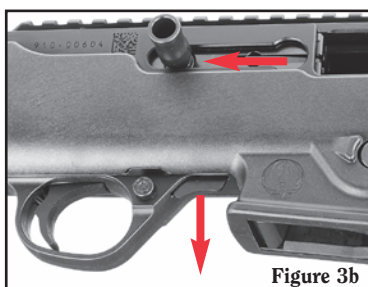
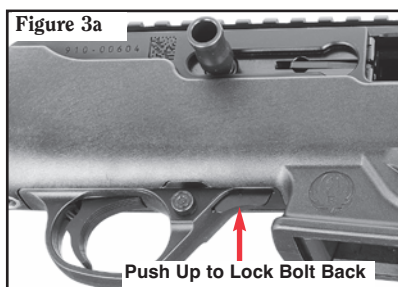

**To release the bolt:** Retract the charging handle to its extreme rearward position and release it. This will cause the bolt stop to drop and the bolt to be released and move forward. (See Figure 3b.)

When the last shot has been fired and the magazine is empty, the last round hold open automatically holds the bolt open. If a loaded magazine is inserted in the rifle when the bolt is closed and the bolt is then retracted fully, the last round hold open will not automatically hold open the bolt. The user can actuate the bolt stop mechanism to hold the bolt open at any time by retracting the bolt with the charging handle and pushing up the bolt stop.

# MAGAZINE WELL REMOVAL & REPLACEMENT

## Make Sure Gun Is Unloaded!

The magazine well of the **RUGER® PC CARBINE™** is interchangeable to accommodate alternative magazines. The **PC CARBINE™** is shipped with a **RUGER® SRS®** magazine well installed and a Glock® magazine well in the shipping box. **RUGER AMERICAN PISTOL®** magazine well assemblies are available at ShopRuger.com.

**NOTE:** Older Glock® magazines that feature only one magazine latch slot may still be used with the **PC CARBINE™**, but the magazine release button must remain on the left side of the rifle as shipped from the factory. The magazine release button should not be reversed when using this type of magazine as the magazine will not properly lock into the magazine well.

### To remove the magazine well:

1. With the rifle pointing in a safe direction, remove the magazine, move the bolt to the rearward position and manually engage the bolt stop. Visually inspect the chamber to make certain that the rifle is unloaded.
2. To remove the barrel/forend assembly, with the bolt still in the rearward position, push the locking lever forward to unlock the barrel/forend assembly (see Figure 4).
3. Rotate the barrel/forend assembly **counterclockwise** and pull the barrel/forend assembly out of the receiver (see Figure 4).

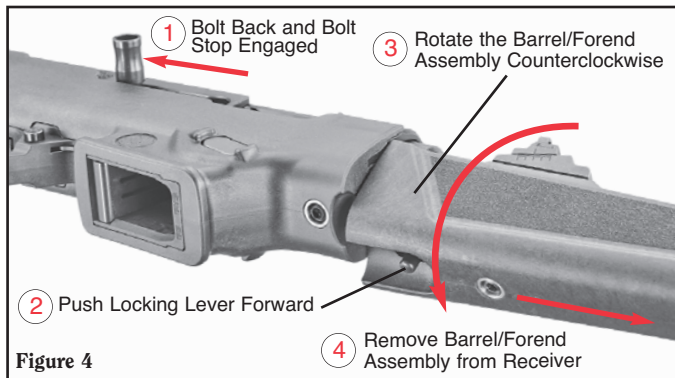

4. Place the charging handle in the forward position (see “To release bolt” instructions p. 12). Place the safety in the “ON” position (see Figure 1C, p. 8).
5. Use a 5/32” hex wrench to loosen (do not remove) the take-down screws from the buttstock. (See Figure 5.)

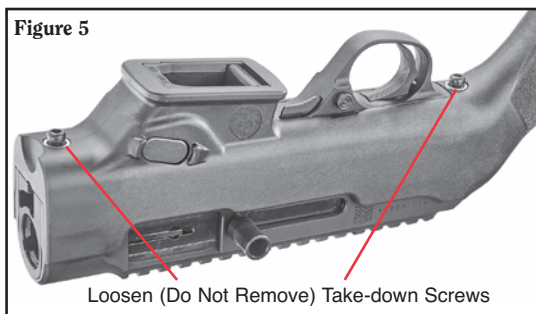

- Lift the receiver assembly upward and away from the buttstock. (See Figure 6.)

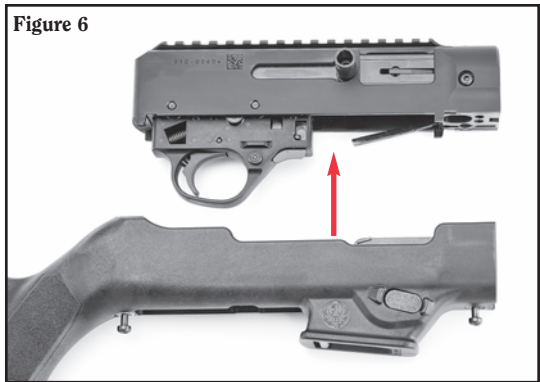

- In order to remove the magazine well assembly, the magazine release button and magazine latch must both be compressed (see Figure 7a) while removing the magazine well upward and out of the stock (see Figure 7b). **NOTE:** The Glock® insert does not require magazine latch compression.

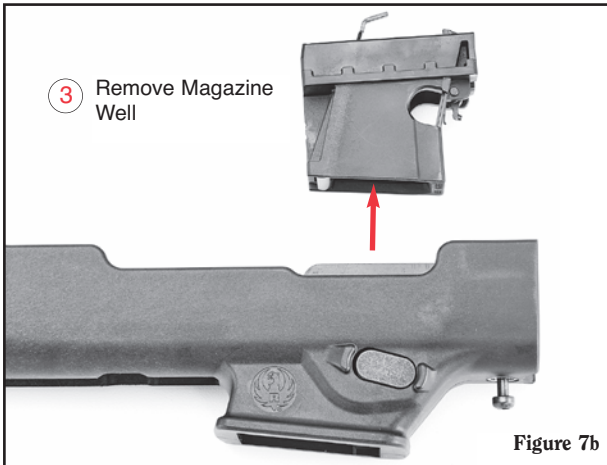
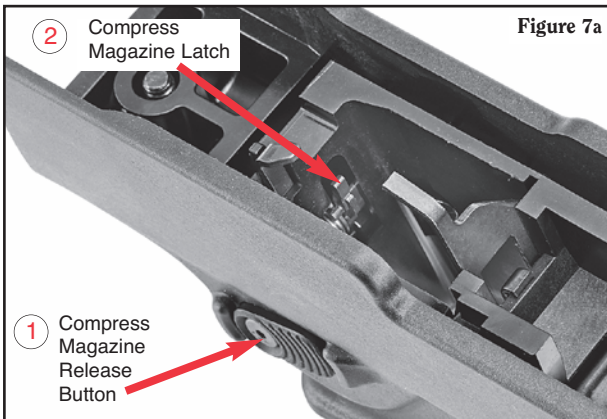

### To insert the magazine well:

1. Compress the magazine latch and magazine release button while inserting the magazine well into the stock (refer to Figures 7a and 7b, p. 14).

2. Place the action into the stock (see Figure 8).

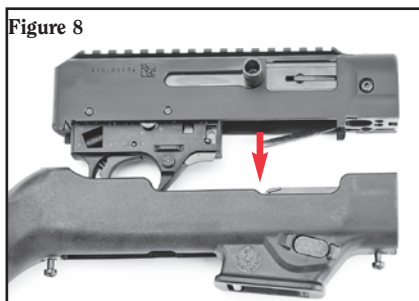

3. Secure the two #10-32 take-down screws to 65 inch-pounds with a 5/32" hex wrench (see Figure 9).

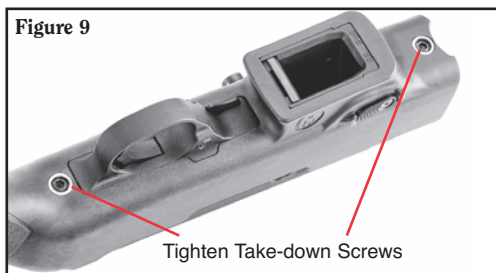

4. Place the bolt in the rearward position and manually engage the bolt stop.
5. Install the barrel/forend assembly by inserting it into the receiver as shown in Figure 10, and rotating it **clockwise** until it locks into place.

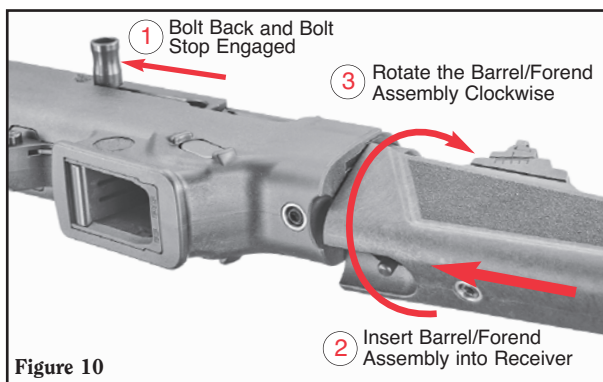

# AMBIDEXTROUS MAGAZINE RELEASE

The magazine release of the **RUGER® PC CARBINE™** can be configured for both left- and right-handed operation.

**NOTE:** Older Glock® magazines that feature only one magazine latch slot may still be used with the **PC CARBINE™**, but the magazine release button must remain on the left side of the rifle as shipped from the factory. The magazine release button should not be reversed when using this type of magazine as the magazine will not properly lock into the magazine well.

1. In order to remove the magazine release, the barrel/forend assembly must be removed (see p. 13, step 2 and Figure 4) from the action and the bolt must be placed in the forward position. (See Figure 11.)

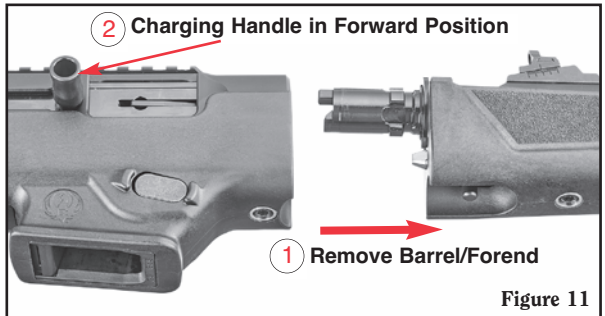

2. A 5/32" hex wrench must then be used to loosen (but do not remove) the two take-down screws on the bottom of the stock. The action must then be removed from the stock, as well as the magazine well assembly. (See Figure 12.)

Removal of the magazine well assembly is further detailed in the "Magazine Well Removal and Replacement" section, p. 13.

3. Using a 5/64" hex wrench, loosen and remove the cap screw retaining the magazine release button, the latch stud spring and the magazine release stud. (See Figure 13.)

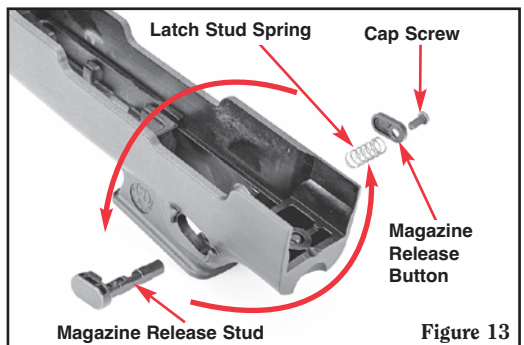
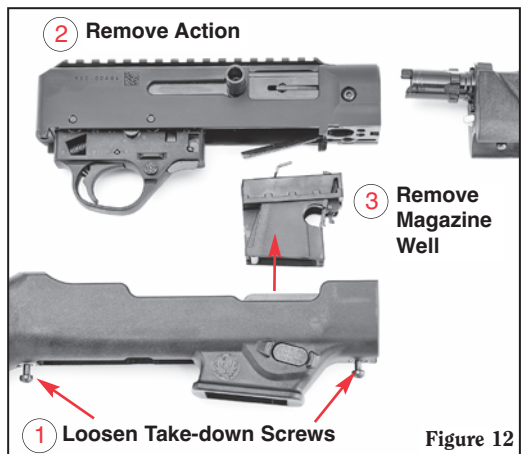

The magazine release stud can then be inserted into the opposite side of the stock. The latch stud spring is then inserted into the opposing end of the magazine release stud. The magazine release button compresses the latch stud spring and is retained by the cap head screw, torqued to 15 inch-pounds.



# AMBIDEXTROUS CHARGING HANDLE

The charging handle of the **RUGER® PC CARBINE™** can be configured for both left- and right-handed operation.

1. In order to remove the charging handle, the barrel/forend assembly must be attached to the action and the bolt must be in the forward position. (See Figure 14.)



**Figure 14.** Location of Charging Handle for Disassembly

2. A 5/32" hex wrench must then be used to loosen the cap screw within the charging handle (see Figure 15). Once loosened and removed, the charging handle assembly (comprised of the charging handle and cap screw) can be inserted on the opposite side of the rifle.

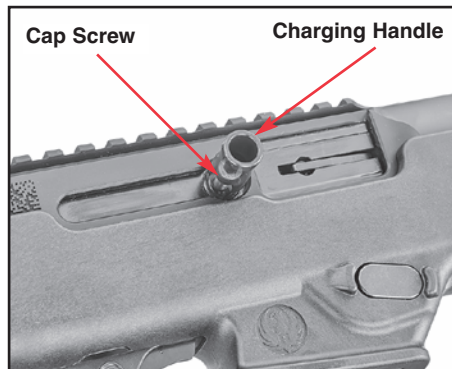

**Figure 15.** Loosen & Remove Charging Handle

3. With the bolt closed, align the conical base of the charging handle with the corresponding countersink on the bolt by passing through the charging handle slot of the receiver (see Figure 16). Tighten the cap screw to 65 inch-pounds to ensure the handle is secure. The charging handle torque should be verified every 1000 rounds or whenever the charging handle is removed and reinstalled.

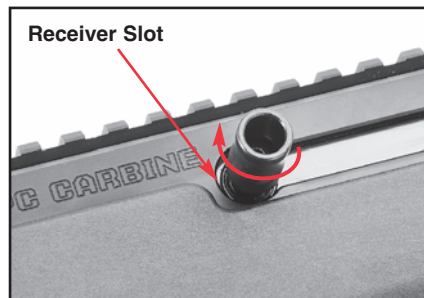

**Figure 16.** Insert & Tighten Charging Handle

## SIGHT ADJUSTMENT

The rear sight is adjustable for both windage and elevation. To adjust elevation, the slide must be moved one graduation to change the point of impact by approximately .85" at 50 yards. Using a 1/16" hex wrench, loosen the set screw (see Figure 17a). Move the slide in the direction you want the bullet to move. When the slide is positioned at the desired height, carefully tighten the set screw (see Figure 17a).

To adjust for windage, loosen the set screw (see Figure 17b). Move the aperture in the direction you want the bullet to move. When the aperture is positioned in the desired location, carefully tighten the set screw (see Figure 17b).

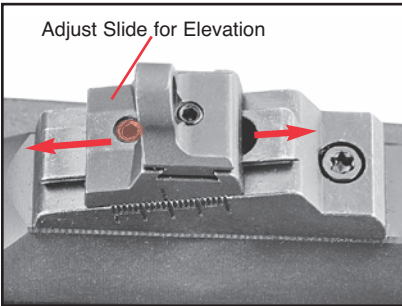

Figure 17a

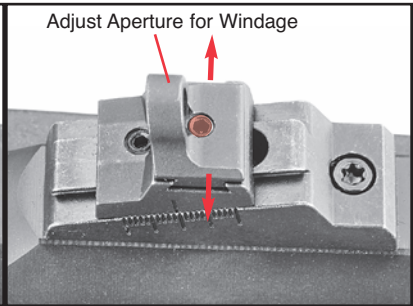
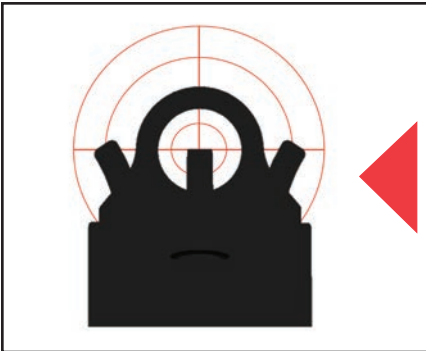

Figure 17b

## SUGGESTED SIGHT PICTURE



Front sight post centered in the rear sight aperture.

## THREAD PROTECTOR

The **RUGER® PC CARBINE™** comes with a 1/2"-28 threaded muzzle and corresponding thread protector. The thread protector is retained in position by a factory installed O-Ring when manually tightened (see Figure 18). If any other muzzle device is used other than the factory provided thread protector, the O-Ring must be removed. Removing the O-Ring ensures that:

1. alternative muzzle devices shoulder out on the barrel, and
2. concentricity of the muzzle device relative to the bore is maintained.

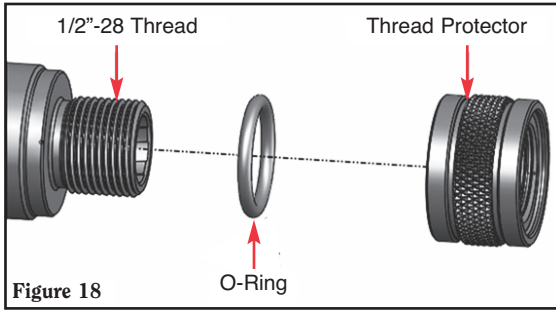

## LENGTH OF PULL ADJUSTMENT

Each **RUGER® PC CARBINE™** comes from the factory with three 1/2" spacers (one installed on the rifle and two packaged separately) that allow you to adjust the length of pull from 12-5/8" to 14-1/8" in one-half-inch increments. As shipped from the factory with a single spacer installed, the length of pull is set at 13-1/8".

To adjust the length of pull, simply add or remove spacers, as desired. To add or remove spacers, use the 9/64" Allen wrench supplied with the rifle to remove the recoil pad screws affixing the recoil pad to the stock (see Figure 19). Add (by

stacking) or remove spacers to achieve the desired length of pull.

Now reattach the recoil pad by installing the recoil pad screws using the allen wrench. Be careful not to overtighten the screws, which should just be snugged in place by turning the screws an additional 1/2 turn after the screw makes contact with the recoil pad.

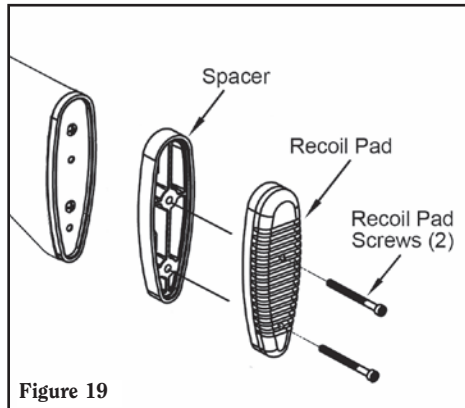

# OPERATION OF SAFETY

The **RUGER® PC CARBINE™** has a cross-button safety which is located in the forward portion of the trigger guard (See Figure 1C, p. 8.) The safety can be operated only when the hammer is cocked.

The safety is “ON” when it protrudes fully from the right side (the ejection side) of the trigger guard assembly, as shown in Figure 1C, p. 8. In this position the sear is blocked, and the gun cannot be fired from a normal pull on the trigger.

The safety should always be in the “ON” (safe) position except when the shooter is actually firing the gun. The safety should be moved to the “ON” position whenever the shooter ceases firing, even temporarily.

The safety is “OFF” (fire) when it protrudes from the left side of the trigger guard assembly, as shown in Figure 20. When the safety is off, the red band shows on the safety button. Do not totally rely on the appearance of the red band to indicate that the safety is off. In poor light or if dirt is present, the red band may not be visible. **If the safety is “OFF” and the trigger is pulled, the rifle will fire.**

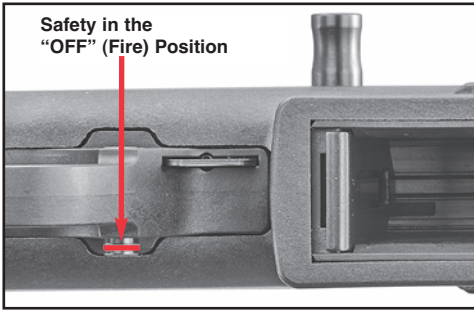

**Figure 20.** The underside of the trigger guard section of the rifle. In this illustration, the safety is shown in the “OFF” (fire) position. The position of the safety and red band indicate the safety is “OFF.” **If the rifle is loaded, the safety should be “OFF” only when you are actually firing at a target.**

The safety is held in its “ON” or “OFF” position by a plunger that is under spring compression. When the safety is moved to either the “ON” or “OFF” position, a distinct “click” should be heard. Frequently check the position of the safety to be certain the safety has not been inadvertently moved. If the safety seems to move too easily, or if the “click” is not heard when the safety is moved, stop using the rifle and return it to the Newport Customer Service Department for repair (see p. 41).



## WARNING – MANUAL SAFETY





Keep the safety “ON” unless actually firing. Always move the safety fully to its intended position and check it. The safety is not “ON” unless it is completely “ON.” Never depend on a safety mechanism or any other mechanical device to justify careless handling or permitting the rifle to point in an unsafe direction. The only “safe” rifle is one in which the bolt is open, the chamber is empty, and there is no magazine in the gun.

**KNOW HOW TO USE THE SAFETY**

## AMMUNITION



The **RUGER® PC CARBINE™** is chambered for, and designed to properly function with, only factory loaded 9mm Luger (Parabellum) standard, high velocity, or +P ammunition, manufactured to U.S. industry standards.

Use only such factory ammunition in good condition that exactly matches the caliber of your rifle that is rollmarked on the receiver.

		<b>WARNING – AMMUNITION</b>
	Death, serious injury, and damage can result from the wrong ammunition, bore obstructions, powder overloads or incorrect cartridge components. <u>Always</u> wear shooting glasses and hearing protection.	
	<b>IMPROPER AMMUNITION DESTROYS GUNS</b>	

### AMMUNITION (CARTRIDGES) NOTICE

WE SPECIFICALLY DISCLAIM RESPONSIBILITY FOR ANY DAMAGE OR INJURY WHATSOEVER OCCURRING IN CONNECTION WITH, OR AS A RESULT OF, THE USE IN ANY RUGER FIREARMS OF FAULTY, OR NON-STANDARD, OR “REMANUFACTURED” OR HAND-LOADED (RELOADED) AMMUNITION, OR OF CARTRIDGES OTHER THAN THOSE FOR WHICH THE FIREARM WAS ORIGINALLY CHAMBERED.

		<b>WARNING – LEAD EXPOSURE</b>
	Discharging firearms in poorly ventilated areas, cleaning firearms, or handling ammunition may result in exposure to lead and other substances known to the State of California to cause birth defects, reproductive harm, and other serious physical injury. Have adequate ventilation at all times. Wash hands thoroughly after exposure.	
		<b>SHOOTING OR CLEANING GUNS MAY EXPOSE YOU TO LEAD</b>

# MAGAZINES

Depending upon the magazine well installed, the **PC CARBINE™** will accept the **RUGER® SR9®** (9mm Luger), and Glock® 9mm magazines. It will also accept 9mm **RUGER AMERICAN PISTOL®** magazines which are offered for sale at [ShopRuger.com](http://ShopRuger.com).

**NOTE:** Be sure the appropriate magazine well is installed in your rifle. Refer to the “Magazine Well Removal & Replacement” instructions on p. 13. Use only high-quality pistol magazines which are clean and in good working order. Ruger® magazines that have been tested and approved for use with the **PC CARBINE™** are available through Ruger® Accessories sales Monday through Friday, 7:30 a.m. - 6:00 p.m. at 1-336-949-5200 ET or 24 hours a day, 7 days a week on the web at [ShopRuger.com](http://ShopRuger.com).

## LOADING THE MAGAZINE

Use only clean, dry ammunition of the proper caliber manufactured to U. S. Industry specifications, in good condition. (See Notice and Warnings in other sections of this manual pertaining to Ammunition).

To load the magazine, align a cartridge with the bullet forward and slide under the feed lips until the cartridge snaps into place. Repeat this process until the desired number of cartridges are loaded. Do not attempt to load more than the designated number of cartridges for which the magazine has been designed.

**DAMAGED, NON-STANDARD OR IMPROPERLY ASSEMBLED MAGAZINES SHOULD NOT BE USED. THEY CAN CAUSE THE RIFLE TO MALFUNCTION.**

## TO LOAD AND FIRE (WITH MAGAZINE)



Practice this important aspect of gun handling (with an unloaded rifle) until you can perform each of the steps – described below – with skill and confidence. But before you do anything with the rifle, please first read completely through this manual. **Keep your finger off the trigger until you are ready to immediately shoot at a target!**

1. **Keep the muzzle pointed in a safe direction.** (See Rule 2, p. 50).
2. **If the hammer is cocked, put the safety “ON”** (fully protruding from the right side of the trigger guard). (See Figure 1C, p. 8.)

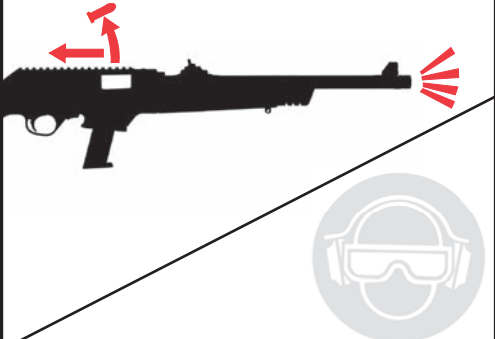
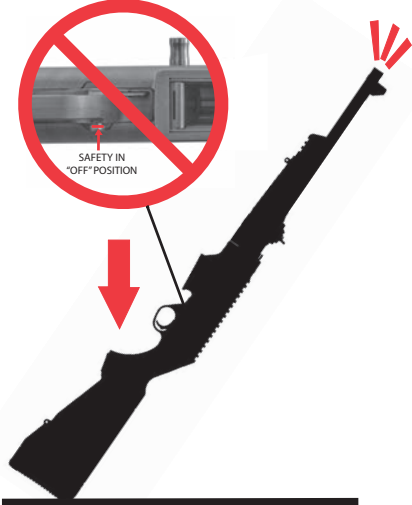

**Figure 21.** If the hammer is cocked, the safety should be “ON” when the magazine is being removed or inserted. When the magazine release button is pushed in, the magazine is released. Depress the button with your thumb and at the same time grasp the magazine and draw it downward out of the gun. **REMEMBER** to check to be sure the chamber is empty after removing the magazine!

3. Pull the charging handle rearward. Engage the bolt stop so that the bolt is held open. **Check the chamber to be certain it is empty.**
4. To remove the magazine, use your thumb to depress the magazine release button on the left or right side of the magazine well and at the same time grasp the magazine between your fingers and palm of the same hand to draw it out of the magazine well. (See Figure 21, p. 22). Do not drop the magazine out of the rifle onto a hard or dirty surface -- you may damage it or otherwise induce malfunctions.
5. Load a magazine with the desired number of cartridges.
6. Insert magazine fully into the firearm (with bullet end of the cartridges toward the muzzle) until it is locked in place by the magazine latch. (Magazine cannot be seated if inserted incorrectly).
7. Load a cartridge into the chamber by fully retracting the charging handle, and then releasing the charging handle. The bolt will forcibly move forward, chambering a cartridge from the magazine. **Don't touch the trigger.** Do not 'ride' the charging handle as it moves forward. Do not apply force to the charging handle to chamber a cartridge. If a cartridge does not readily chamber, eject it from the rifle, hold the bolt open with the bolt stop, remove the magazine and see MALFUNCTIONS WARNING, p. 29.
8. The rifle is now fully loaded. **If the rifle is not to be fired immediately, the safety should remain "ON"** (see Figure 1C, p. 8). When the safety is moved to the "OFF" position, the rifle will fire a cartridge each time the trigger is pulled until all the cartridges in the magazine, and the one in the chamber, have been fired. Firing will automatically reload and recock the rifle. **Note that every time the trigger is pulled, if a cartridge is in the chamber and the safety is "OFF," the rifle will fire – be careful!**

 <b>WARNING – FIRING</b>	
	<p>The bolt automatically opens and shuts quickly while firing. Keep face and hands away from it. Hot brass and powder gas are ejected quickly and can burn you. The rifle should be fired from the right shoulder. Always wear shooting glasses and hearing protection.</p>
	<b>BOLT OPENS FAST– HOT BRASS EJECTED</b>

9. Immediately following the firing of a shot, if a subsequent shot is not to be fired at once, put the safety "ON" while the rifle is still pointing in a safe direction down range. The safety should be moved to the "ON" position as soon as firing is completed, and it should be "ON" at all times except when the rifle is on target and being fired.
10. If all cartridges are fired from the magazine, the bolt remains open after the last shot has been fired. When firing is completed, if the bolt is shut, manually retract the bolt, hold it open by pushing the bolt stop up, and visually check the chamber to be sure it is empty. **If the bolt is shut, you should always assume that there is a cartridge in the chamber. Don't rely on your memory to know if a gun or magazine is loaded. Visually inspect the magazine and the chamber.**



 <b>WARNING – HANDLING</b>	
 <p style="text-align: center;">SAFETY IN "OFF" POSITION</p>	<p>If dropped or struck with the safety "off", the rifle may fire. Keep chamber empty unless actually firing! Keep safety "ON" unless actually firing!</p>
<b>ANY GUN MAY FIRE IF DROPPED</b>	



## TO LOAD AND FIRE (WITHOUT MAGAZINE)

The rifle can be used as a single-shot rifle in the absence of a magazine or for safety or training purposes. To do so, follow steps 1 through 3, on pp. 22 - 23. Next, carefully place a single cartridge into the chamber. The chamber can be accessed through the ejection port. Retract the charging handle to its extreme rearward position and release it. This will cause the bolt to be released and move fully forward. The rifle is now loaded.

If the rifle is not to be fired immediately, the safety should remain "ON." Firing the rifle will cock the hammer though, without a magazine, the bolt will not remain open after the single round is fired.

 <b>WARNING – UNLOADING</b>	
	<p>So that the rifle can be used as a single loader, it will fire whether or not a magazine is in the gun if a cartridge is chambered. Removing the magazine does not unload the rifle! To unload, first remove magazine, then pull bolt to the rear, eject chambered cartridge, and visually inspect chamber. <b>If the hammer is cocked, the safety should always be in the "ON" (safe) position when loading or unloading the rifle.</b></p>
	<b>GUN WILL FIRE WITH MAGAZINE OUT</b>

## TO UNLOAD

**(Rifle Must Be Kept Pointed In A Safe Direction)**

**UNLOAD THE RIFLE IMMEDIATELY WHEN YOU ARE FINISHED SHOOTING!**

**NOTE:** This sequence must be followed exactly as spelled out. Failure to do so can result in the rifle's chamber becoming unintentionally loaded with a cartridge!

1. Keep the muzzle pointed in a safe direction at all times and keep fingers outside the trigger guard. If the rifle is cocked, **move the safety to the "ON" position.**
2. Remove the magazine. **Remember that even though the magazine has been removed, a cartridge remaining in the chamber can still be fired!**
3. Retract the bolt to its open position and hold it in place by pressing the bolt stop up, (see p. 12).
4. **Always visually double check the chamber to be certain it is empty.**
5. The only "safe" rifle is one in which the bolt is open, the chamber is empty, and there is no magazine in the gun.

## CORRECT UNLOADING SEQUENCE

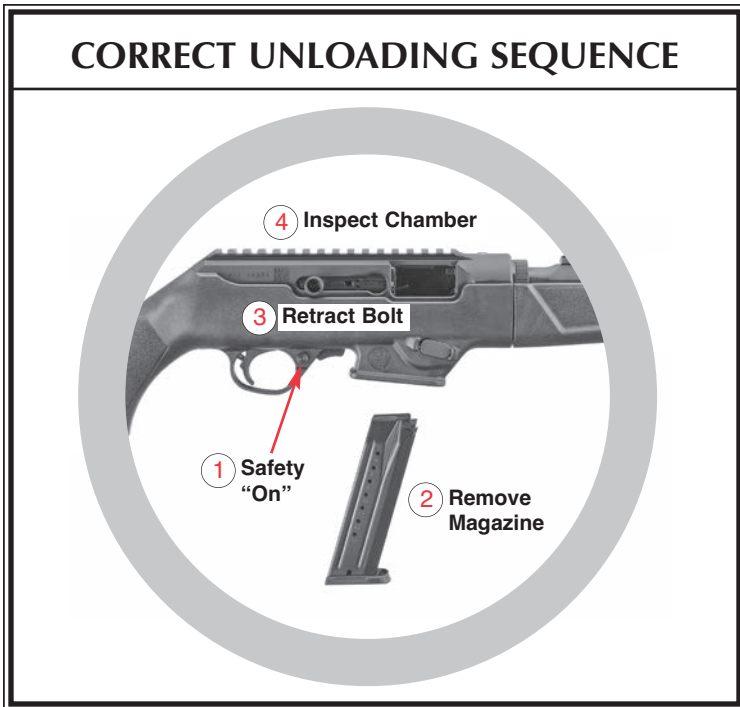

6. Cartridges can be removed from the magazine by sliding each cartridge forward and out of the magazine, one at a time, until the magazine is empty. **Do not use a loaded cartridge as a 'tool' to strip cartridges from the magazine.**
7. If desired, the bolt can be left in the open position, being held there by the bolt stop. **If it is desired to close the bolt, again look to be certain the chamber is empty. Put the safety "ON," retract the bolt to its rearmost position, release and let the bolt snap forward. **Keep your fingers out of the receiver!****
8. **With the muzzle pointed in a safe direction,** push the safety to the "OFF" position and pull the trigger to decock it. The rifle can be "dry fired" for practice **as long as it is empty and pointed in a safe direction.**
9. Push empty (unloaded) magazine into the rifle until the magazine latch locks it in place. If an empty magazine is inserted into a rifle with the bolt held open, the bolt will not close due to the last round hold open.

## TO EXTRACT AND EJECT A CHAMBERED CARTRIDGE

When the rifle is fired, the same gas pressure which drives the bullet forward also acts through the cartridge case to push the bolt to the rear. That action causes extraction and ejection of the fired cartridge case. But, when the bolt is operated by hand, there can be a failure to extract the cartridge from the chamber, or a failure to eject the cartridge clear of the rifle. These failures usually are the result of the bolt not being pulled rearward vigorously, coupled with an accumulation of firing residue in the chamber. From the foregoing, it is clear that the gun user must:

1. **Always visually check the chamber after opening the bolt to eject a chambered cartridge.** If the bolt is not vigorously retracted when being operated by hand, the extracted cartridge can be 'ejected' into the magazine area, instead of outside the rifle. (Remember that the magazine should be removed prior to unloading the chamber.)
2. Thoroughly clean the chamber and the extractor as often as necessary to prevent the accumulation of grease and dirt.
3. If an empty magazine is in the rifle when the bolt is being hand retracted to extract a cartridge, the cartridge may drop on top of the magazine. **Always remove the magazine before clearing the chamber, and visually ensure that no cartridges remain in the gun.**

## TO CLEAR A MALFUNCTION ("JAM")

Any autoloading firearm may occasionally malfunction. If it does:

1. **Be certain the muzzle is pointed in a safe direction and the safety is "ON."**
2. If possible, first remove the magazine. It may be necessary to manually remove a jammed cartridge which has only partially been stripped from the magazine.

If so, use extreme care. Hold the bolt open with the bolt stop before attempting to clear the jam. Drawing the bolt fully to the rear may bring the jammed cartridge along. **Keep your face away from the ejection port during this operation.** When attempting to clear a jam, use only wood 'tools' so that a cartridge will not be ignited if you strike a primer, and so that the chamber and magazine will not be damaged. A 3/16" wood dowel rod with a point on one end is useful.

3. Visually check to make sure all cartridges have been removed from the rifle. Safely dispose of any cartridges involved in a malfunction incident. Do not use damaged ammunition in any firearm.

## TO MINIMIZE MALFUNCTIONS (“JAMS”)

Most malfunctions are caused by improper or damaged magazines, incorrect ammunition, or poor maintenance.

1. If it appears that the gun and magazine are not at fault and that the jam was caused by the type of cartridge being used, then try another type.
2. If changing to another type or brand of cartridges does not at once eliminate malfunctioning, then the following steps should be taken:
  - a. **Make certain the gun and the magazine are unloaded and that the safety is “ON.” Remember, the magazine should be removed first, then check the chamber and be certain it and the magazine well are clear of cartridges.**
  - b. Thoroughly clean the magazine and bolt mechanism (see p. 33 for detailed instructions on how to disassemble the bolt for cleaning), paying particular attention to removing accumulated grease. Use a bristle brush and solvent to remove grease and fouling from the bolt, the extractor, the chamber, and the feed ramp. (See the “Care and Cleaning” section of this manual for detailed cleaning instructions).
  - c. Check to see that the magazine spring tension is adequate and that the magazine follower moves freely up and down.
  - d. Check the magazine lips to be certain they are free of nicks and burrs and are not deformed.
  - e. Remove excess oil and solvent from all cleaned components, load the magazine, and try the firearm again. As always, proceed slowly. **Be certain bystanders are not close and that you are wearing eye and hearing protection and that your face is a safe distance from the rifle so that any discharge resulting from a jammed cartridge will not injure anyone.**

If the above procedures do not result in a smooth and reliably functioning firearm, do not use the gun. The rifle can be returned directly to our Newport, New Hampshire Customer Service Department for repair. See the Service and Parts Policy section p. 41 of this manual for packing and shipping information.

**Another precaution:** When using any autoloading firearm, form the habit of examining fired cartridge cases. If they have bulged heads or frequently show splits on any part of the case, the rifle should be returned to the factory for inspection.



## WARNING – MALFUNCTIONS



A cartridge fires when the firing pin impacts the primer, and also can be “discharged” before it is chambered if its primer receives a sharp blow. If a cartridge hangs up, jams, or binds when being chambered or when being fed from the magazine into the chamber, **do not attempt to force it into the chamber by pushing or striking the charging handle.** Any jam or feeding problem is a signal to immediately stop using the gun until it can be determined what is wrong. Most failures of a cartridge to feed or to chamber are caused by a damaged magazine, improper gun handling, or defective ammunition. **Whatever the cause, cartridge jams can result in the potentially dangerous situation of a cartridge discharging before it is chambered. If this occurs, the cartridge case will rupture and its fragments will fly out of the gun with sufficient force to cause injury. Always wear shooting glasses and hearing protectors! Keep face away from chamber!**

**STRIKING CHARGING HANDLE  
CAN BURST CARTRIDGE**



## WARNING – DISASSEMBLY



Always unload a firearm before cleaning, lubrication, disassembly or assembly.

**UNLOAD BEFORE  
CLEANING**

## TO DISASSEMBLE Make Sure Gun Is Unloaded!

An on-line video demonstrating the disassembly and reassembly of the **RUGER® PC CARBINE™** rifle can be viewed by going to [Ruger.com/TechTips](http://Ruger.com/TechTips).

### Rifle Stock and Trigger Guard Disassembly:

1. With the rifle pointing in a safe direction, remove the magazine, lock the bolt back and visually make certain there is not a cartridge in the chamber.
2. To remove the barrel/forend assembly, with the bolt still in the locked back position, push the locking lever forward to unlock the barrel/forend assembly (see Figure 22).
3. Rotate the barrel/forend assembly **counterclockwise** and pull the barrel/forend assembly out of the receiver (see Figure 22).

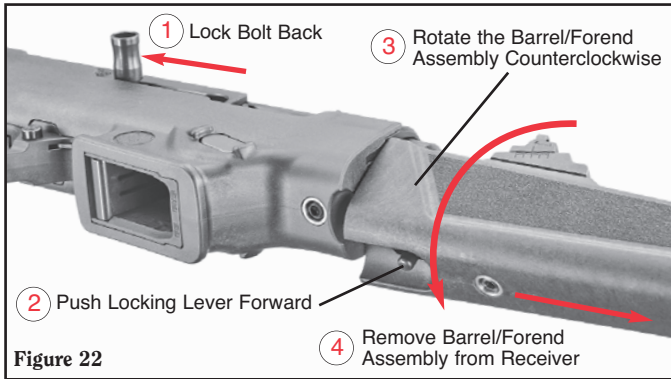

4. Retract the charging handle fully rearward and release it to place the bolt in the forward position. Place the safety in the "ON" position (see Figure 1C, p. 8).

5. Use a 5/32" hex wrench to loosen (do not remove) the take-down screw from the forend. (See Figure 23.)



6. Remove the barrel from the forend. (See Figure 24.)

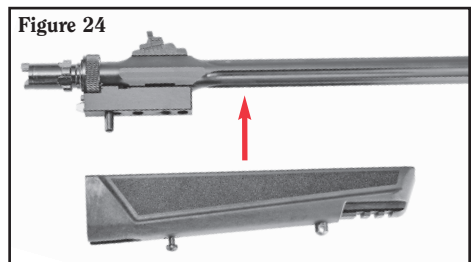

7. Use a 5/32" hex wrench to loosen (do not remove) the take-down screws from the buttstock. (See Figure 25.)

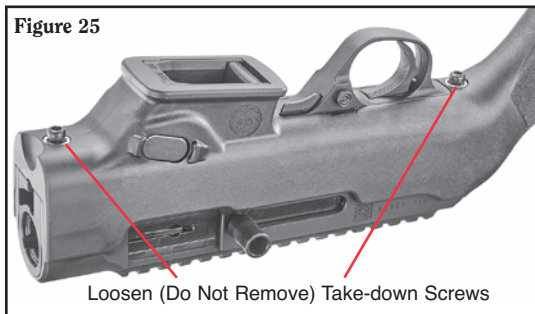

8. Lift the receiver assembly upward away from the buttstock. (See Figure 26.)

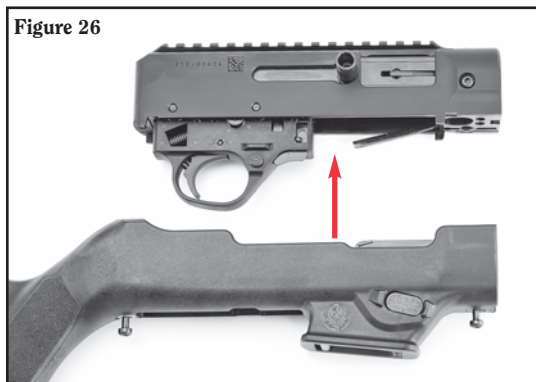

9. Remove the trigger guard by simply drifting out the two trigger guard retaining pins (see Figures 27a & 27b). It is recommended that the components of the trigger guard assembly not be disassembled from the trigger guard.

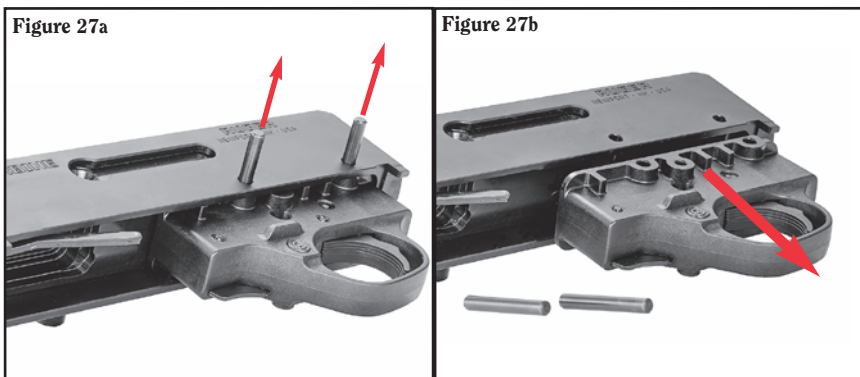

This is the extent of disassembly required for routine inspection, cleaning and lubrication.

If it is desired to thoroughly clean the inside of the receiver by removing the bolt, be aware that although removing and installing the bolt (along with the charging handle-recoil spring assembly) is simple, it must be done correctly.

**To remove the bolt – (See Figures 28a & 28b):**

1. Position the receiver so the bolt is fully accessible.
2. Ensure the bolt is in the forward position by pulling back on and carefully releasing the charging handle.
3. Remove the charging handle as described in the “Ambidextrous Charging Handle” section on page 17.
4. Grasping the buffer, lift the bolt assembly out of the receiver (see Figure 28a).

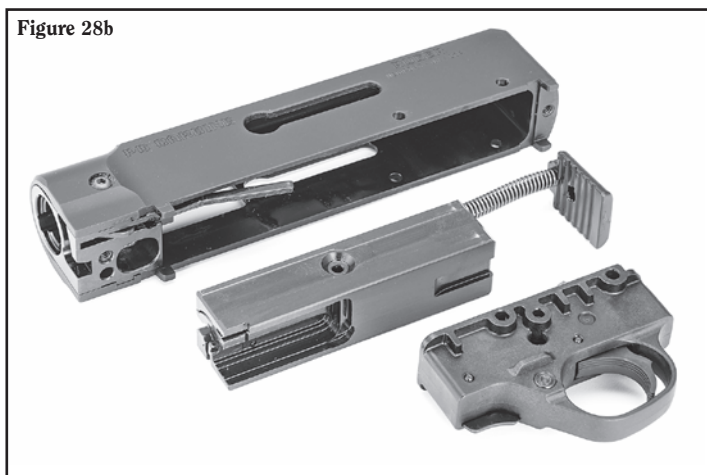
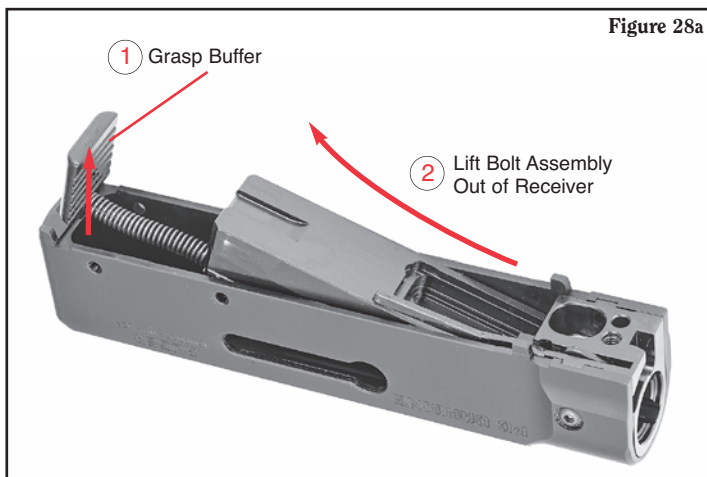



**Disassembly of the bolt for cleaning – (See Figures 29 - 32b):**

It may occasionally be desirable to clean the bolt and firing pin. Before cleaning, the bolt will need to be disassembled as described below.

1. Slide the bolt top assembly out of the bolt (see Figure 29).

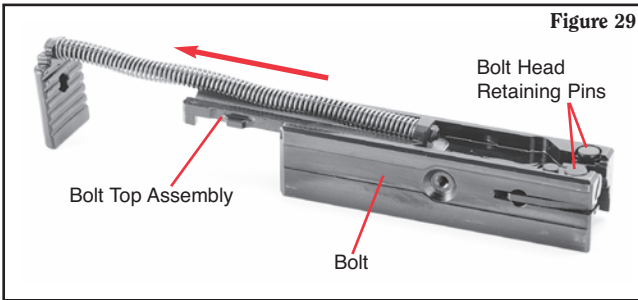

2. Compress the bolt head and flip the bolt over to allow the bolt head retaining pins to drop free (see Figure 30). The bolt head retaining pins are held in place due to spring load from the firing pin return spring.

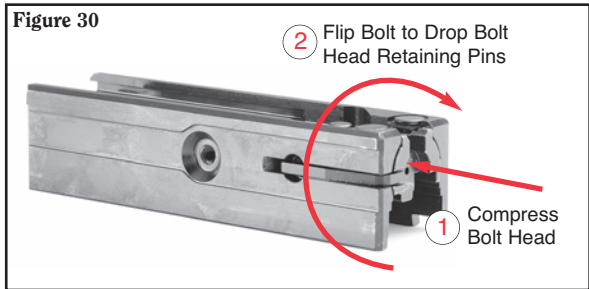

3. Remove the extractor pin. Make sure that the extractor is compressed while removing the pin (see Figure 31a). After the pin is removed, carefully allow the extractor and extractor spring to be removed (see Figure 31b).

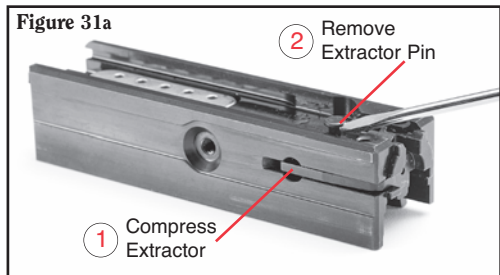

**CAUTION:** The extractor spring is in compression, so be careful when removing the pin and extractor.

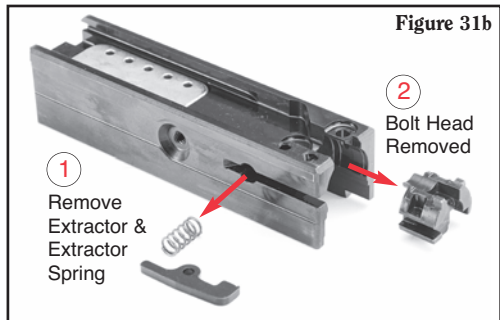

4. Remove the bolt head, the firing pin return spring, and the firing pin (see Figure 32a).
5. Remove the dead blow weight (see Figure 32b).

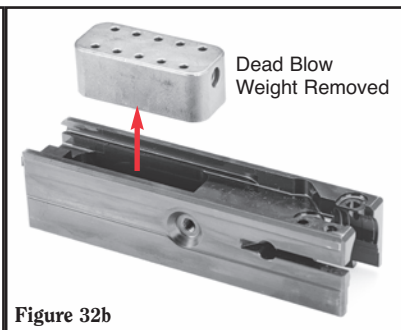
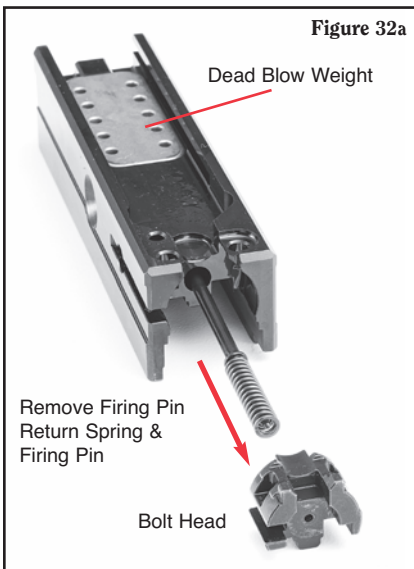

## REASSEMBLY

**Again, Be Sure Rifle is Unloaded!**

**Reassembly of the bolt – (See Figures 33 - 37):**

1. Insert the dead blow weight into the bolt (see Figure 33).
2. Insert the firing pin, then the firing pin return spring into the bolt (see Figure 34).

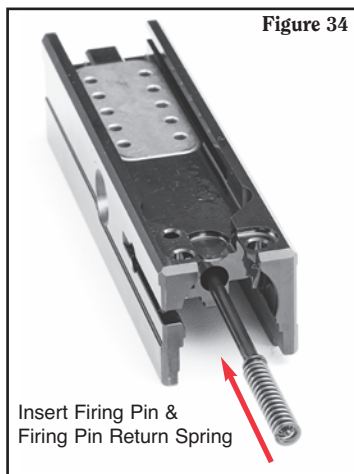
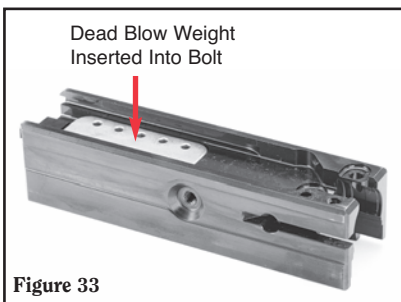

3. Align the bolt head with the bolt, compress the firing pin spring with the bolt head and insert the bolt head retaining pins (see Figure 35).

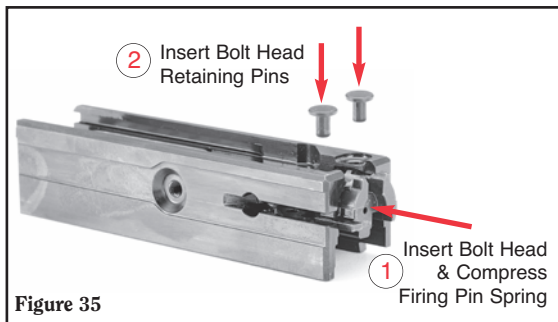

4. Insert the extractor spring and extractor into the extractor hole and slot, respectively. Retain the extractor using the extractor pin (see Figure 36).

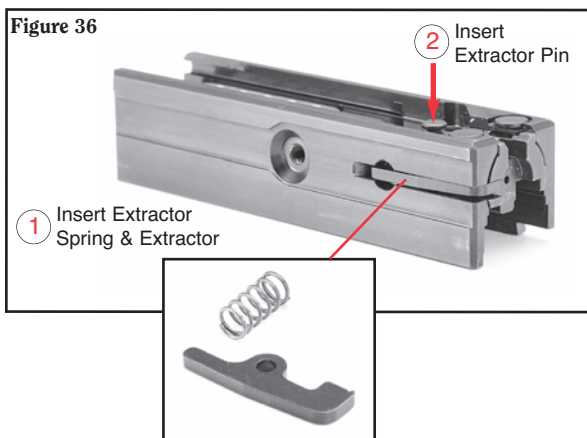

5. Slide the bolt top assembly into the bolt (see Figure 37).

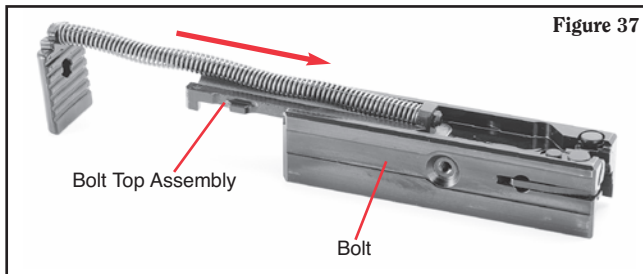

### Reassembly of the bolt into the receiver:

1. Grasping the buffer, place the bolt assembly into the receiver with the bolt top facing the top of the receiver. Slide the bolt forward so the bolt head approaches the barrel block and slide the buffer into the back pocket of the receiver. (See Figure 38.) **NOTE:** Do not compress the bolt head against the barrel block until the bolt is fully captured by the receiver. This will prevent the bolt head retaining pins from being inadvertently dislodged.
2. Position the trigger group in alignment with the trigger retaining pin holes and install the trigger retaining pins. (See Figure 39.) The trigger group helps constrain the buffer in the receiver.
3. Reinstall the charging handle onto the bolt. (See “Ambidextrous Charging Handle” section p. 17.)

The action is now reassembled and can be installed into the stock as described below.

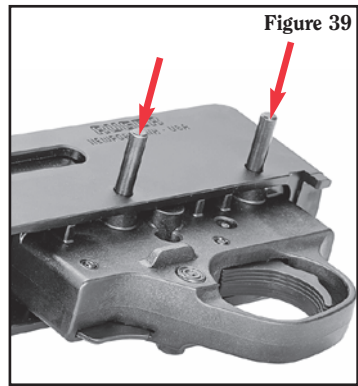
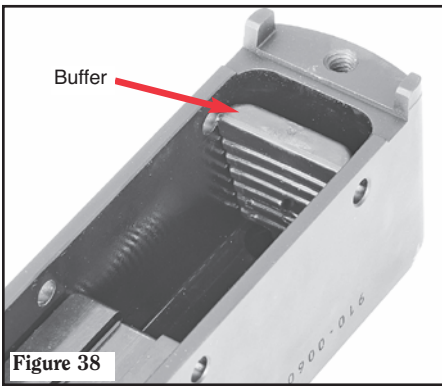

### Reassembly of the stock:

**NOTE:** Be sure a magazine well has been installed in the stock before assembling the barrel/forend assembly. (See “Magazine Well Removal & Replacement Instructions,” p. 13.)

1. Drop the receiver/trigger guard assembly into the buttstock. (See Figure 40.)
2. Use a 5/32" hex wrench to tighten the take-down screws into the buttstock at 65 inch-pounds. (See Figure 41.)

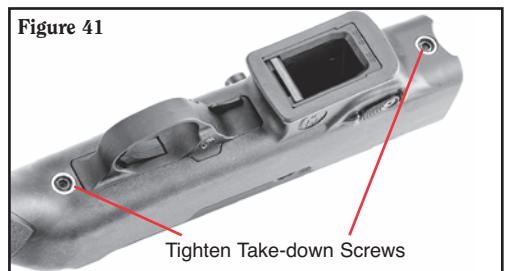
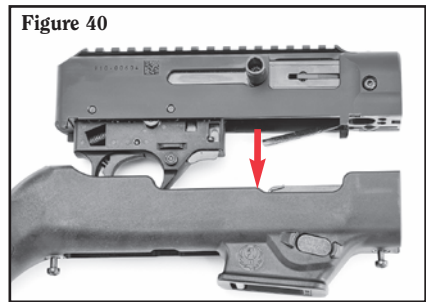

## BARREL/FOREND ASSEMBLY

The **PC CARBINE™** rifle has an adjustable lock-up mechanism. The following directions describe the adjustment necessary to ensure proper lockup the first time the barrel is installed. After the first adjustment, the barrel may be installed by following step 2 **only**.

1. Loosen the adjustment knob by turning it **counter-clockwise** as far as possible with finger pressure. (See Figure 42.)

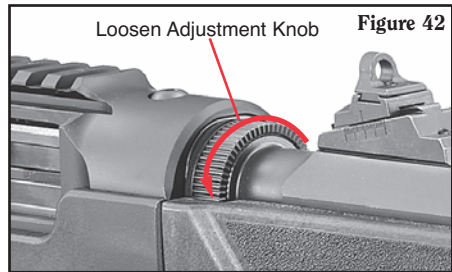

2. Install the barrel/forend assembly by inserting it into the receiver as shown in Figure 43, and rotating it **clockwise** until it locks into place.

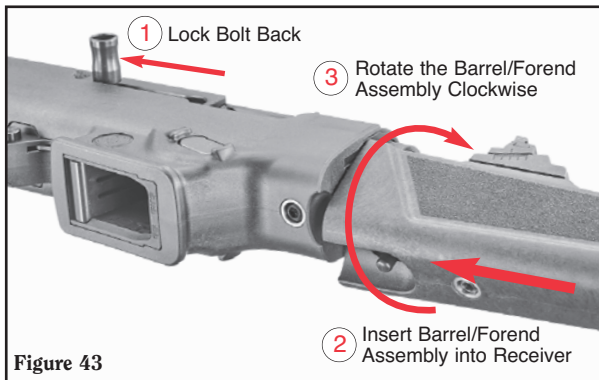

3. Tighten the adjustment knob by rotating it **clockwise** until the barrel/forend assembly is securely connected.

**NOTE:** You should feel some resistance when turning the barrel/forend assembly into the receiver, but it should not be difficult. If further adjustment is needed, remove the barrel/forend assembly and “tighten” or “loosen” the adjustment knob accordingly.

**NOTE:** Following barrel installation, the best fired shot accuracy will be achieved if the action is dry cycled prior to actually firing ammunition in the rifle: Remove the magazine from the rifle and be certain the chamber is empty. Keeping the rifle pointed in a safe direction, pull the bolt handle fully to the rear while holding the bolt lock up, then release the bolt handle, letting it “slingshot” (freely fly forward) into the ready-to-fire position. Repeat 2 - 3 times. This will properly “seat” the barrel assembly.

## MAGAZINE INSPECTION AND CARE

Check the magazine frequently. The magazine follower must move freely and have adequate tension so that each cartridge is quickly raised to the feeding position. The magazine lips should be clean and free of cracks, dents, or nicks, so that cartridges are held in their proper feeding position.

If the magazine becomes dirty, it should be disassembled and thoroughly cleaned. **Be sure the magazine is unloaded before disassembly.** All **RUGER® SRS®** magazines are manufactured with a snap-on base. The following disassembly instructions apply:

**Snap-On Base** - Use a punch to press in on the magazine spring seat where it protrudes into the hole in the magazine floorplate. Slide the magazine floorplate toward the front of the magazine, **be careful to prevent the forcible ejection of the magazine spring seat and compressed magazine spring.** Withdraw the magazine spring seat, magazine spring, and magazine follower from the magazine body. Reassemble in reverse order.

When cleaning is necessary, use a solvent that will not rust the metal components or adversely affect the magazine body. After the magazine has been soaked to loosen foreign matter, be certain to shake it vigorously (with the loading opening away from you) to remove solvent or residue from within the magazine.

Penetrating oils and solvents inside a magazine can “kill” or weaken cartridge primers or powder which can result in failures to fire or other possibly dangerous malfunctions, such as leaving a bullet in the bore!

After cleaning, always check to be certain that the magazine follower movement and tension are correct, and that no solvent or debris remain. **Improper reassembly of the magazine can cause failure to feed, which is a potentially dangerous malfunction.** If cleaning does not restore proper tension, or if you experience a problem with the magazine, don't use it. Get a new one.

**DAMAGED, NON-STANDARD, OR IMPROPERLY ASSEMBLED MAGAZINES SHOULD NOT BE USED. THEY CAN CAUSE THE RIFLE TO MALFUNCTION.**

## CARE AND CLEANING

**BEFORE CLEANING, BE CERTAIN THE RIFLE AND ITS MAGAZINE ARE UNLOADED.**



Cleanliness is most important to the function of this blow-back operated autoloading firearm. Any failures to feed or extract rounds may be indications of a dirty chamber. Use commercially available bore cleaning solution and a brass brush, followed by drying with a cloth patch, to remove any powder residue. **An excess of dirt, powder residue, or oil in the chamber will cause malfunctions and may result in potentially dangerous cartridge case ruptures and release of hot gasses and case fragments when firing.**

At regular intervals, or whenever the rifle has been exposed to sand, dust, extreme humidity, condensation, immersion in water, or other adverse conditions, disassemble, clean and oil it. Proper periodic maintenance is essential to the reliable functioning of any firearm.

An on-line video demonstrating the proper cleaning procedure of the **PC CARBINE™** rifle can be viewed by going to **Ruger.com/TechTips**.

To clean the rifle, proceed as follows:

1. Disassemble (field-strip) the rifle to the extent described on page 30.
2. Using a cleaning rod, run a properly sized, solvent-wetted patch through the bore several times. Then attach a solvent-wetted bristle brush to a cleaning rod and run it back and forth the full length of the bore as many times as necessary to remove grease and dirt from the bore and chamber. Clean bore with dry patches and examine. Bore fouling can contribute to reduced accuracy, and grease accumulation in the chamber can interfere with proper feeding of cartridges from the magazine.
3. Using powder solvent on a clean patch or bristle brush, remove powder residue from all components of the mechanism. After cleaning, run a dry patch through the bore, then follow with a patch that is very lightly oiled. Wipe all surfaces clean with cloth, then wipe all surfaces with a patch or cloth that has been very lightly oiled.

 <b>WARNING – LUBRICATION</b>	
	Firing a rifle with oil, grease, or any other material even partially obstructing the bore may result in damage to the rifle and serious injury to the shooter and those nearby. Do not spray or apply lubricants directly on ammunition. If the powder of a cartridge is affected by the lubricant, it may not be ignited, but the primer firing may push the bullet into the bore where it may be lodged. Firing a subsequent bullet into the obstructed bore may damage the rifle and cause serious injury or death to the shooter and those nearby. Use lubricants properly. You are responsible for the proper care and maintenance of your firearms.
<b>IMPROPER LUBRICATION DESTROYS GUNS</b>	

4. **NOTE:** Only a light application of oil is needed to provide adequate lubrication of moving parts and to prevent rust. Excess accumulations of oil tend to attract particles of dust and dirt and may congeal in cold weather which can interfere with the safe and reliable functioning of the rifle.
5. **Cleaning the Stock:** Use of cleaning solvents containing acetone can damage the finish of your stock.



## STORAGE

**GUNS SHOULD NOT BE STORED LOADED!**

**USE THE LOCKING DEVICE SUPPLIED WITH THE RIFLE TO RENDER IT INOPERATIVE FOR SAFE STORAGE.**

(SEE PAGE 9)

**Do not** store the rifle in a leather case or scabbard. Leather attracts moisture, even though it may appear to be dry.

 <b>WARNING – STORAGE</b>	
	<ul style="list-style-type: none"><li>• Never place or store any firearm in such a manner that it may be dislodged. Firearms should always be stored securely and unloaded, away from children and careless adults.</li><li>• Use the locking device supplied with the rifle for storage. The use of a locking device or safety lock is only one aspect of responsible firearms storage.</li><li>• For increased safety, firearms should be stored unloaded in a location that is both separate from their ammunition and inaccessible to children and any other unauthorized person.</li></ul>
<b>STORE SECURELY &amp; UNLOADED</b>	



## SERVICE AND PARTS POLICY

If you have any question regarding the performance of your **RUGER® PC CARBINE™** rifle please write or call (336-949-5200) our Customer Service Department in Newport, New Hampshire 03773, fully describing all circumstances and conditions involved. If you should return your rifle to the factory for repair, or order parts for it, please comply with the following suggestions for prompt service:



**WARNING: BEFORE SHIPPING ANY FIREARM, BE ABSOLUTELY CERTAIN THAT IT IS UNLOADED. DO NOT SHIP CARTRIDGES WITH A FIREARM.**

## SHIPPING FIREARMS FOR REPAIR

**RUGER® PC CARBINE™** rifles returned to the factory for repair should be sent to: Sturm, Ruger & Company, Inc., Customer Service Department, 411 Sunapee St., Newport, New Hampshire 03773. **NOTE: You must obtain a Repair Authorization Number before returning your firearm.** An authorization number can be obtained by contacting Customer Service online at [www.ruger.com](http://www.ruger.com) or calling the Customer Service Dept. at 336-949-5200. Guns should be sent prepaid. We will not accept collect shipments.

The Federal Gun Control Act, as well as the laws of most states and localities, do not prohibit an individual (who is not otherwise barred from purchasing or possessing a firearm) from shipping a firearm directly to the manufacturer for repair. However, before you ship your rifle to us, be certain that your state or locality does not have a law or regulation which will prohibit you from receiving the rifle from us after it has been repaired. If such receiving is prohibited, then please have a federally licensed firearms dealer ship the gun to us. If your rifle is sent to us by a dealer, it will be returned to that dealer after being repaired. If a handgun (pistol or revolver) is shipped by an individual who does not hold a Federal Firearms License, it must be shipped for overnight delivery via U.P.S., Federal Express or other, similar private overnight service. **NOTE:** Handguns may not be shipped via U.S. Mail. Handguns mailed in violation of the law are impounded by the Post Office. Rifles and shotguns may be shipped via U.S. mail.

Please do not include a rifle case, sling, telescopic sights or custom accessories with a firearm being shipped to the factory for service. **DO NOT SEND GUN BOXES OR LITERATURE THAT YOU CONSIDER TO BE COLLECTOR'S ITEMS – THESE ARE INVARIABLY DAMAGED OR DESTROYED IN SHIPMENT.** Always insure your shipment.

Enclose a letter which includes your name, address, telephone number, serial number, model of the firearm, and your repair authorization number. Describe in detail the trouble you have experienced with your firearm, or the work you wish to have done. Merely stating that the firearm “needs repair” is inadequate information.

All work performed is subject to a minimum labor charge and charges for shipping and handling. Most models can be reblued, but custom gunsmithing service or nonstandard alterations are NOT AVAILABLE from Ruger Customer Service Departments. Please contact the Customer Service Department for pricing information.

 <b>WARNING – PARTS PURCHASERS</b>	
	<ul style="list-style-type: none"><li>• It is the purchaser's responsibility to be absolutely certain that any parts ordered from the factory are correctly fitted and installed.</li><li>• Firearms are complicated mechanisms and <b>IMPROPER FITTING OF PARTS MAY RESULT IN A DANGEROUS MALFUNCTION, DAMAGE TO THE FIREARM, AND SERIOUS INJURY TO THE SHOOTER AND OTHER PERSONS.</b></li><li>• The purchaser and installer of parts must accept full responsibility for the correct adjustment and functioning of the firearm after such installation.</li></ul>
<b>PARTS MUST FIT CORRECTLY</b>	

## ORDERING PARTS

Please contact the New Hampshire Customer Service Department for parts availability and current prices. All parts ordered for the **RUGER® PC CARBINE™** should be sent to: Sturm, Ruger & Co., Inc., Customer Service Department, 411 Sunapee Street, Newport, New Hampshire 03773, 336-949-5200. We cannot comply with open account or C.O.D. orders. Payment in full via credit card (Visa or MasterCard only), money order or certified bank check (no personal checks or cash, please) is required before any service will be performed. Please provide your credit card number, your name as it appears on the credit card, the expiration date, and the 3-digit security code. All parts orders are subject to a minimum charge and charges for shipping and handling. Order parts by **Part Name and specify the model and entire serial number** of the firearm for which the parts are being ordered. There is a minimum labor charge plus a shipping and handling charge if the parts are factory fitted. All factory fitted parts are fit on an exchange basis only. We will not return the replaced parts. Please contact the Customer Service Department for pricing information.

Because the receiver is a serial numbered component, it is defined as a “firearm” by Federal law and is not sold as a separate component.

\*Parts designated by an asterisk must be factory fitted. These parts are fitted on an exchange basis only. We will not return the replaced parts. We will not return any part that is broken, malfunctioning, badly worn or has been modified. See “Warning – Parts Purchasers” above.

	<b>WARNING: A gun containing broken, malfunctioning, or badly worn parts should not be fired.</b>
---	---

# RUGER® PC CARBINE™

## PARTS LIST

Design, prices and specifications subject to change without notice.

**SPECIFY MODEL, CALIBER AND SERIAL NO. WHEN ORDERING**

(See Exploded Views Pages 45 - 49)

<b>Key</b>	<b>Part Name</b>
<b>1</b>	<b>Stock Assembly – Complete</b> <b>Includes Key Nos. 2 - 11 (See Exploded View p. 45)</b>
2	Low Profile Cap Screw
3	Magazine Release Button
4	Magazine Release Spring
5	Magazine Release Stud
6	Stock Assembly
7	Butt Pad Holder
8	Butt Plate Screw, 2 Req'd
9	Pad Spacer
10	Recoil Pad Assembly
11	Recoil Pad Screws
<b>12</b>	<b>Forend/Barrel Assembly – Complete</b> <b>Includes Key Nos. 13 - 32 (See Exploded View p. 46)</b>
13	Thread Protector
14	O-Ring
15	Front Sight
16	Sight Screws, 4 Req'd
17	Forend Assembly
18	Locking Lever
19	Mounting Screws, 2 Req'd
20	Takedown Block
21	Detent Spring
22	Detent Plunger
23	Locking Plunger Spring
24	Locking Plunger Detent
25	Locking Plunger
26	Barrel Spacer
27	Adjustment Ring
28	Barrel
29	Rear Sight Base
30	Rear Sight Slide
31	Rear Sight Aperture
32	Set Screws, 2 Req'd
<b>33</b>	<b>Magazine Well Assemblies (SR9/G9/American) – Complete</b> <b>Includes Key Nos. 34 - 42 (See Exploded Views p. 47)</b>
34	Ejector
35	Magazine Well, SR9
36	Last Round Plunger
37	Latch Pin
38	Magazine Latch, SR9
39	Magazine Latch Spring
40	Magazine Well, G9

\* Parts so marked must be factory fit.

<b>Key</b>	<b>Part Name</b>
41	Magazine Well, American 9mm
42	Magazine Latch, American 9mm
43	Last Round Catch
44	Last Round Spring
45	Last Round Pivot Pin
46	Barrel Block
<b>* 47</b>	<b>Trigger Assembly – Complete</b> <b>Includes Key Nos. 48 - 66 (See Exploded View p. 48)</b>
* 48	Hammer Strut Washer
* 49	Hammer Strut Spring
* 50	Hammer Strut
* 51	Hammer
* 52	Hammer Pivot Pin
* 53	Trigger Guard
54	Bolt Stop
55	Bolt Stop Spring
* 56	Trigger Pivot Pin
* 57	Trigger Plunger Spring
* 58	Trigger Plunger
* 59	Safety Detent Plunger Spring
* 60	Safety Detent Plunger
* 61	Safety Button
* 62	Trigger
* 63	Sear
* 64	Disconnecter Pin
* 65	Disconnecter
* 66	Disconnecter Spring
67	Socket Head Cap Screw
68	Charging Handle
<b>69</b>	<b>Bolt Assembly – Complete</b> <b>Includes Key Nos. 70 - 83 (See Exploded View p. 48)</b>
70	Bolt
71	Extractor
72	Extractor Spring
73	Extractor Pin
74	Bolt Head
75	Bolt Head Retaining Pins, 2 Req'd
76	Firing Pin
77	Firing Pin Spring
78	Buffer
79	Recoil Spring
80	Recoil Spring Retainer
81	Bolt Top
82	Guide Rod
83	Dead Blow Weight
84	Trigger Guard Cross Pins, 2 Req'd
† 85	Receiver
86	Button Head Screws, 3 Req'd

\* Parts so marked must be factory fit.

† The receiver is a serial-numbered part and is not offered for sale.

**RUGER® PC CARBINE™**  
**STOCK ASSEMBLY**

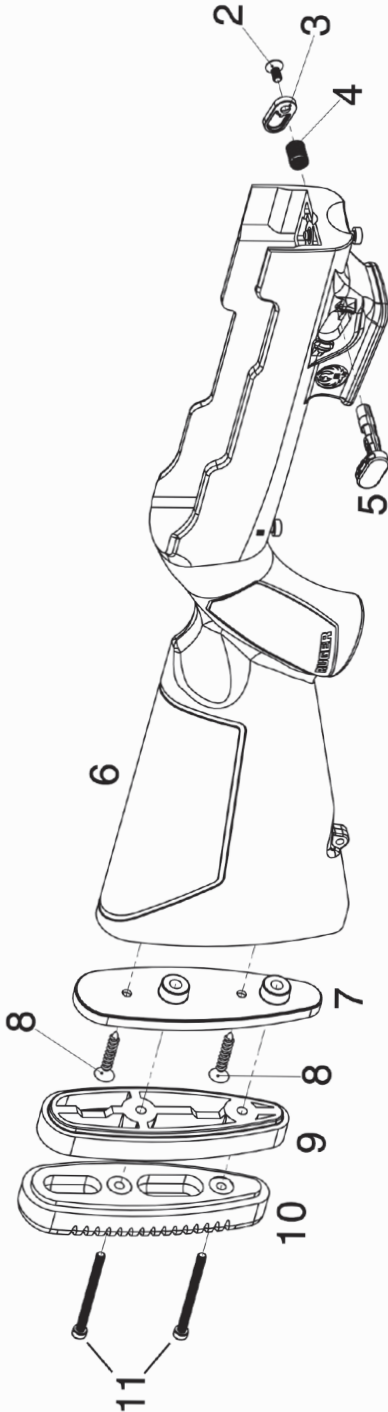

**RUGER® PC CARBINE™**  
**FOREND/BARREL ASSEMBLY**

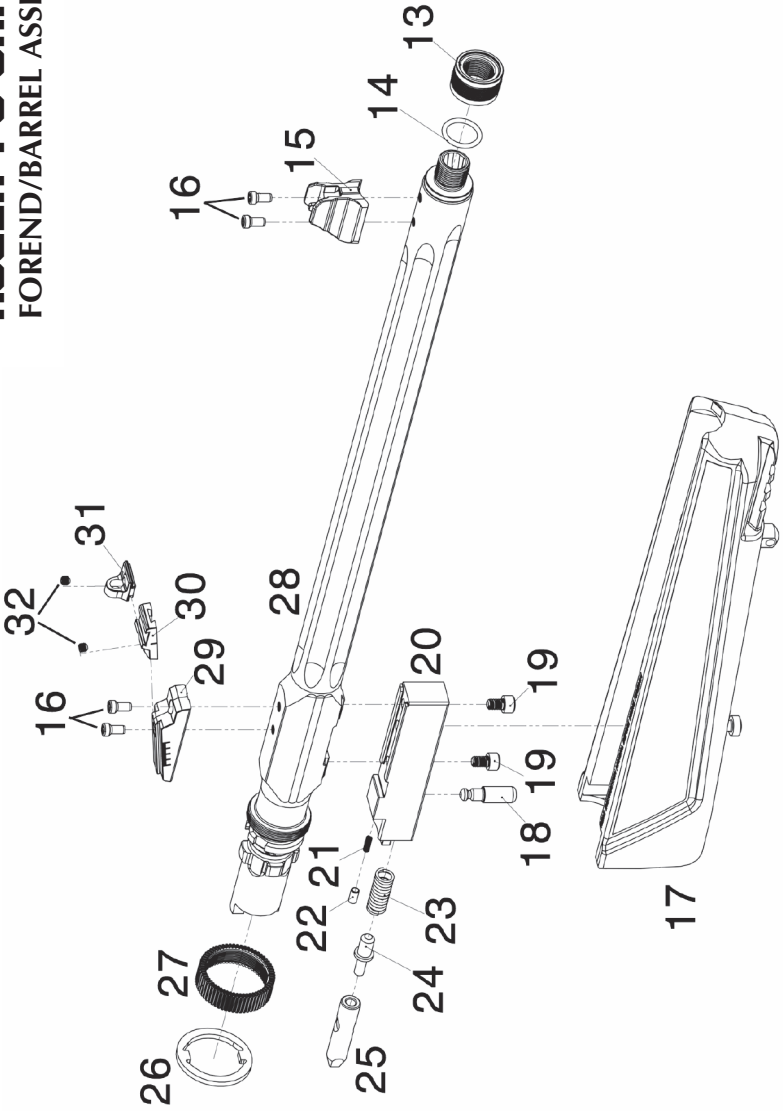

**RUGER® PC CARBINE™**  
MAGAZINE WELL ASSEMBLIES

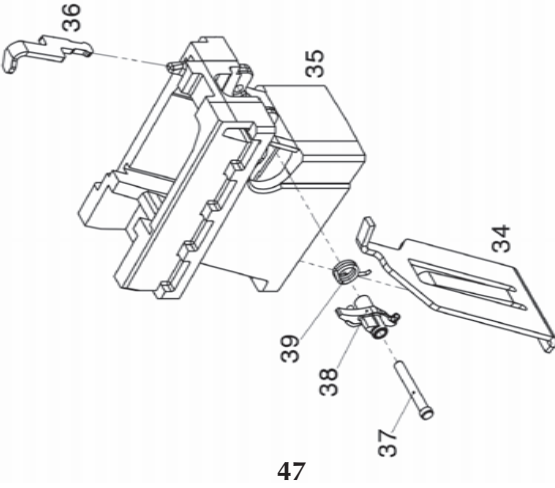

**SR9 ASSEMBLY**

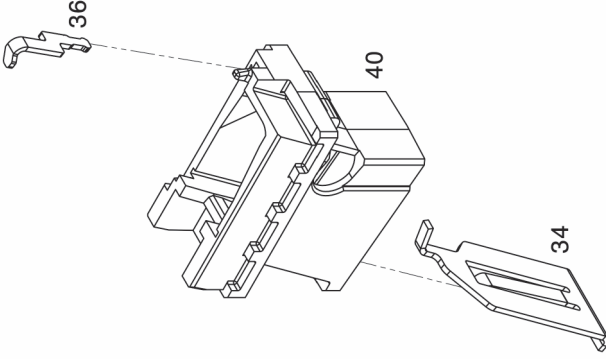

**G9 ASSEMBLY**

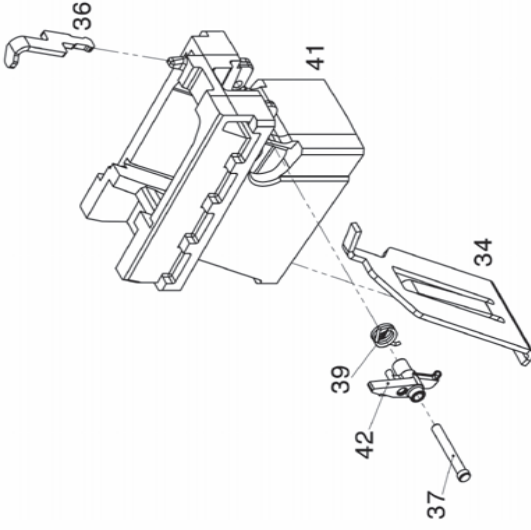

**AMERICAN ASSEMBLY**

# RUGER® PC CARBINE™

## TRIGGER ASSEMBLY

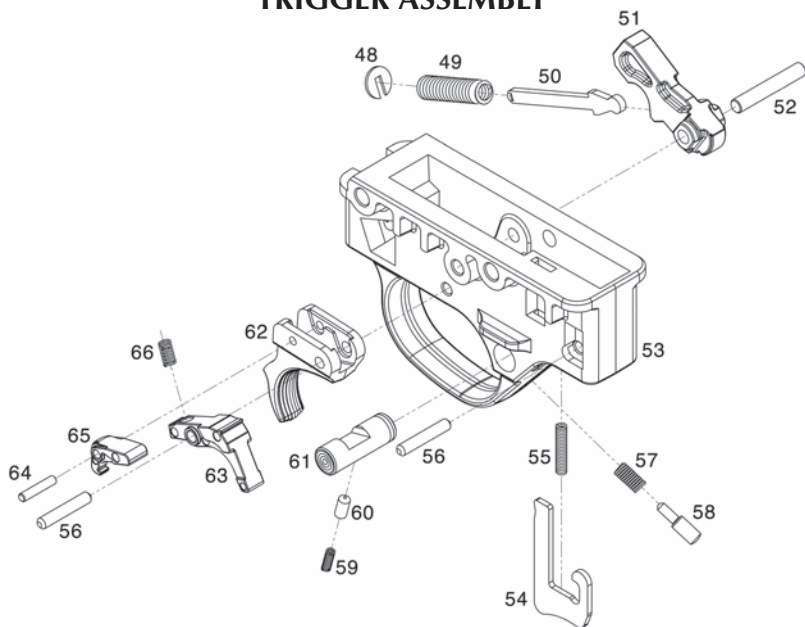

# RUGER® PC CARBINE™

## BOLT ASSEMBLY

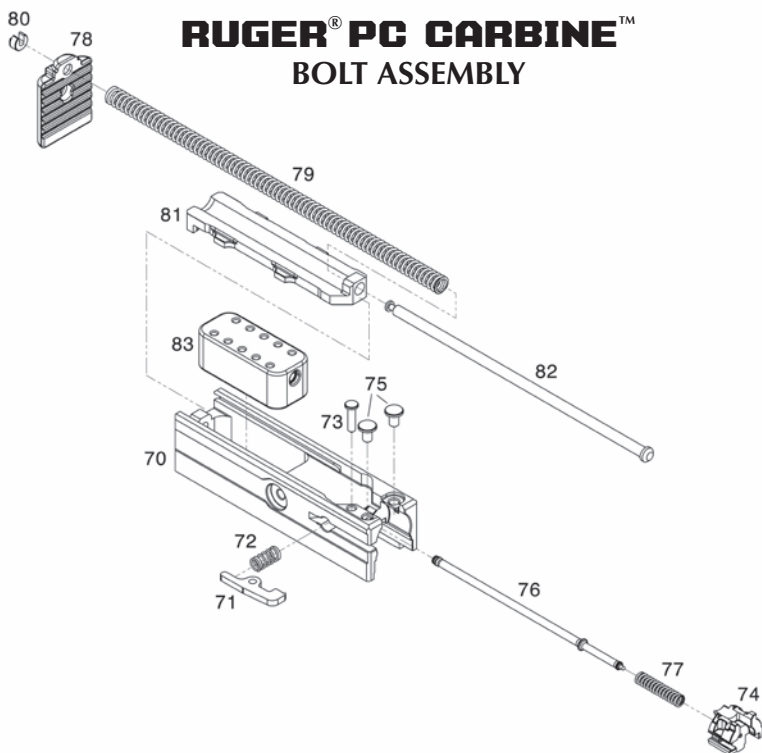



# RUGER® PC CARBINE™

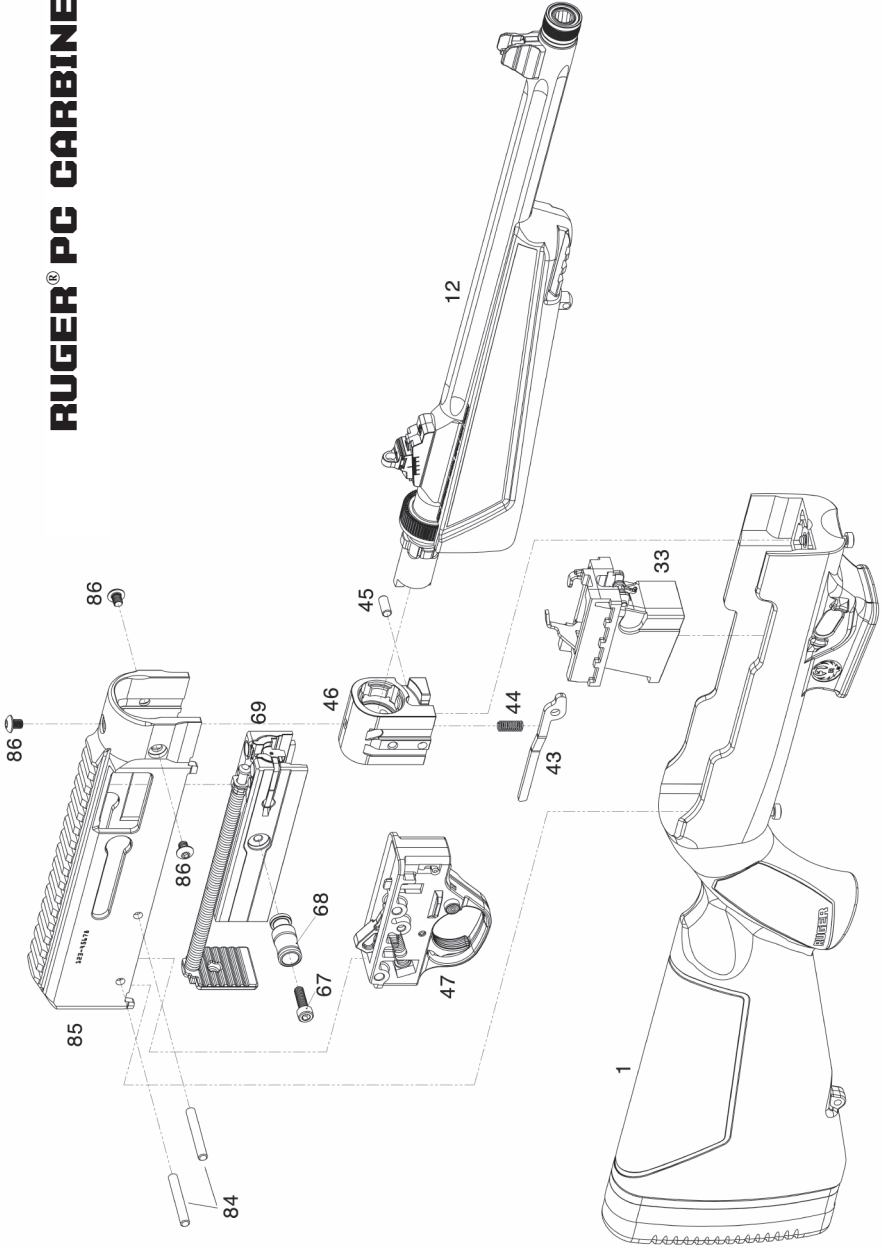

## THE BASIC RULES OF SAFE FIREARMS HANDLING

We believe that Americans have a right to purchase and use firearms for lawful purposes. The private ownership of firearms in America is traditional, but that ownership imposes the responsibility on the gun owner to use his firearms in a way which will ensure his own safety and that of others. When firearms are used in a safe and responsible manner, they are a great source of pleasure and satisfaction, and represent a fundamental part of our personal liberty.

Firearms do not cause accidents! Firearms accidents are almost always found to have been the result of carelessness or ignorance on the part of the shooter of the basic rules of safe gun handling.

The following rules must be observed by gun users at all times. Safe gun handling is not just desirable, it is absolutely essential to your safety, the safety of others, and the continuation of gun ownership and sport shooting as we know it today.

### 1. LEARN THE MECHANICAL AND HANDLING CHARACTERISTICS OF THE FIREARM YOU ARE USING.

Not all firearms are the same. The method of carrying and handling firearms

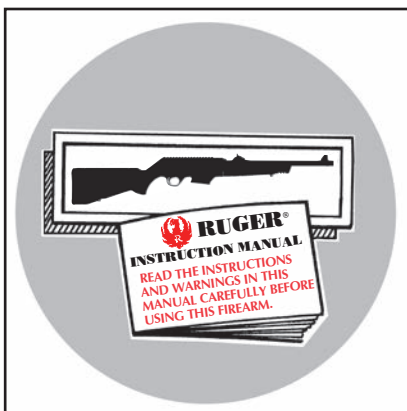

varies in accordance with the mechanical provisions for avoiding accidental discharge and the various proper procedures for loading and unloading. No person should handle any firearm without first having thoroughly familiarized himself with the particular type of firearm he is using, and with safe gun handling in general.

### 2. ALWAYS KEEP THE MUZZLE POINTED IN A SAFE DIRECTION.



Be sure of the bullet stop behind your target, even when dry-firing. Never let the muzzle of a firearm point at any part of your body or at another person. This is particularly important when loading or unloading a firearm. In the event of an accidental discharge, no injury can occur as long as the muzzle is pointing in a safe direction. A safe direction means a direction that will not permit a discharged bullet to strike a person, or to strike an object from which the bullet may ricochet.

A safe direction must take into account the fact that a bullet may penetrate a wall, ceiling, floor, window, etc., and strike a person or damage property. Make it a habit to know exactly where the muzzle of your gun is pointing whenever you handle it, and be sure that you are always in control of the direction in which the muzzle is pointing, even if you fall or stumble. Keep your finger off the trigger until you are ready to shoot.

### 3. FIREARMS SHOULD BE UNLOADED WHEN NOT IN USE.

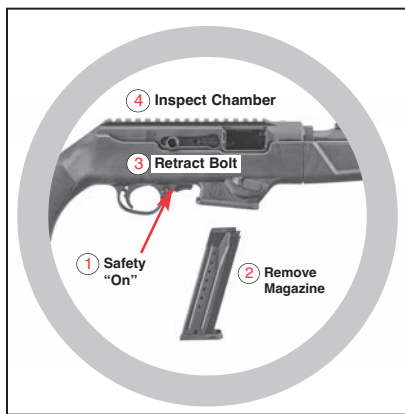

Firearms should be loaded only when you are in the field or on the target range or shooting area, ready to shoot. Firearms and ammunition should be securely locked in safes, racks or cabinets, or by using the locking device supplied with the firearm, when not in use.

Ammunition should safely be stored separate from firearms. Store your firearms out of sight of visitors and children. It is the gun owner's responsibility to be certain that children and persons unfamiliar

with firearms cannot gain access to firearms, ammunition, or components.

### 4. BE SURE THE BARREL IS CLEAR OF OBSTRUCTIONS BEFORE SHOOTING.

Even a bit of mud, snow or excess lubricating oil or grease in the bore may cause the barrel to bulge, or even burst on firing, and can cause serious injury to the shooter and bystanders. Be sure that you are using ammunition of the proper caliber and loading for the gun you are using. If the report or recoil on firing seems weak, or doesn't seem quite right, **CEASE FIRING IMMEDIATELY**, unload your firearm, and check to be sure that no obstruction has become lodged in the barrel. Never try to shoot out an obstruction!

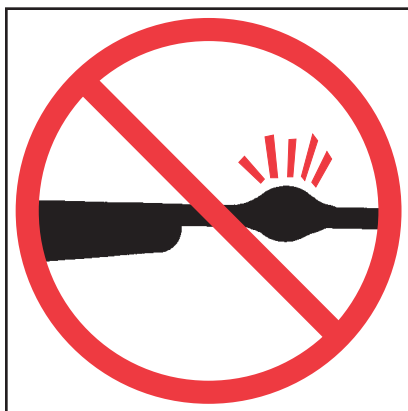



### **5. BE SURE OF YOUR TARGET BEFORE YOU SHOOT.**

Don't shoot unless you know exactly where your bullet is going to strike. Be sure of the bullet stop behind your target, even when dry-firing with an unloaded gun. If you are in the field hunting, do not fire at a movement or noise. Take the time to be absolutely certain of your target before you pull the trigger.

### **6. WEAR SHOOTING GLASSES AND HEARING PROTECTION WHEN YOU SHOOT.**

All shooters should wear protective shooting glasses and adequate hearing protection when shooting. Exposure to shooting noise can damage hearing, and wearing adequate eye protection when shooting is essential.



### **7. NEVER CLIMB A TREE OR FENCE WITH A LOADED FIREARM.**

Put the firearm down carefully before climbing a fence, and unload it before climbing or descending a tree or jumping over a ditch or other obstruction. Never pull or push a loaded firearm toward yourself or another person. When in doubt, or whenever you are about to do anything awkward, unload your gun!

**8. DON'T SHOOT AT A HARD SURFACE OR AT WATER.**

Bullets can glance off many surfaces like rocks or the surface of water and travel in unpredictable directions with considerable velocity.



**9. NEVER TRANSPORT A LOADED FIREARM.**

Firearms should always be unloaded before being placed in a vehicle. A suitable carrying case or scabbard should be used to carry an unloaded firearm to and from the shooting area.

**10. AVOID ALCOHOLIC BEVERAGES WHEN SHOOTING.**

Don't drink until the day's shooting is over. Handling firearms while under the influence of alcohol in any form, or medications that could affect your judgment or coordination, constitutes a criminal disregard for the safety of others.



## **A BRIEF ACCOUNT OF AN EXTRAORDINARY ACHIEVEMENT: RUGER® FIREARMS**

Sturm, Ruger & Company, Inc., had its beginning in a small machine shop occupying a rented frame building in Southport, Connecticut. In January, 1949, with an initial investment of only \$50,000 and an idea, William B. Ruger and Alexander M. Sturm started production of a .22 caliber autoloading pistol—a design which was so successful that it became the cornerstone upon which one of the most comprehensive lines of sporting firearms ever made in America was established. After Alex Sturm's death in 1951, William B. Ruger continued to direct the Company until his death in 2002. William B. Ruger, Jr. continued to provide guidance, which helped make this Company a sound and successful enterprise, until his retirement in 2006. The Company has continued to prosper, under new management and guidance from our Board, with new products and fresh perspectives.

Ruger, in this relatively short time, has established itself as a leading small arms design organization, developing a unique and broad line of fine quality sporting, military and police firearms to become one of the world's most famous producers of revolvers, pistols, rifles and shotguns. Since 1949, Ruger craftsmen have built many millions of firearms.

During its six decades of growth and progress under the leadership of William B. Ruger, the Company developed a business philosophy and implemented policies which represent a constructive influence in the life of modern America. From the beginning, Ruger played a positive role in conservation efforts and has supported the interests of shooters through such groups as the National Rifle Association, National Shooting Sports Foundation, and many regional sportsmen's organizations.

The Company has always endeavored to market its firearms for constructive and recreational purposes, to emphasize the traditional and responsible aspects of shooting, to render meaningful public services, and to encourage shooters in constructive, responsible, and safe participation in the shooting sports. Its motto, "Arms Makers For Responsible Citizens®," exemplifies this Company philosophy.

Today, Ruger® is particularly mindful of those elements which have contributed to the creation of its success, and extends heartfelt thanks to its many loyal employees and customers.

The firearms catalog, and instruction manuals for all Ruger® firearms, can be downloaded from our website at:

**[www.ruger.com](http://www.ruger.com)**

## NOTES

## WHY NO WARRANTY CARD HAS BEEN PACKED WITH THIS NEW RUGER® FIREARM

The Magnuson-Moss Act (Public Law 93-637) does not require any seller or manufacturer of a consumer product to give a written warranty. It does provide that if a written warranty is given, it must be designated as "limited" or as "full" and sets minimum standards for a "full" warranty. Sturm, Ruger & Company, Inc. has elected not to provide any written warranty, either "limited" or "full", rather than to attempt to comply with the provisions of the Magnuson-Moss Act and the regulations issued thereunder. There are certain implied warranties under state law with respect to sales of consumer goods. As the extent and interpretation of these implied warranties varies from state to state, you should refer to your state statutes. Sturm, Ruger & Company wishes to assure its customers of its continued interest in providing service to owners of Ruger® firearms.



**STURM, RUGER & Company, Inc.**  
411 Sunapee Street  
Newport, New Hampshire 03773 U.S.A.  
[www.ruger.com](http://www.ruger.com)

**Arms Makers For Responsible Citizens®**

A COPY OF THE INSTRUCTION MANUAL FOR ANY RUGER®  
FIREARM IS AVAILABLE FROM THE FACTORY FREE ON REQUEST, OR IT MAY BE  
DOWNLOADED FROM OUR WEBSITE AT [WWW.RUGER.COM](http://WWW.RUGER.COM).

THESE INSTRUCTION MANUALS CONTAIN IMPORTANT  
WARNINGS WHICH MUST BE UNDERSTOOD  
BEFORE USING THESE FIREARMS.

**The Following are Sturm, Ruger & Co., Inc. Trademarks:** "BX-Trigger," "Bisley," Eagle Hard "R" logo holding gun, "Elite 452," "Gold Label," "I'm a Ruger American," "LC6," "LCR-357," "LC380CA," "Mark II," "Mark III," "Match Champion," "Model 96," "P345," "P345D," "P345PR," "P85," "P90," "P91," "P93," "P94," "P95," "P97," "R.I.O.S.," "Ruger Marksman Adjustable," "Ruger 77/50," "Ruger 10/17," "Ruger Titanium," "Security-Six," "Service-Six," "77/357," "Single-Seven," "Speed-Six," "SR45," "SR-556C," "SR-556VT," "SR-762," "Super Bearcat," "Target Grey," "10/22-FS," "This is Ruger. This is America," "Tri-Flex," "22 Charger," "22/45," and "22/45 RP."

**The Following are Registered U.S. Trademarks Belonging to Sturm, Ruger & Co., Inc.:** "AC-556," "AR-556," "Arms Makers For Responsible Citizens," "All-Weather," "Bearcat," "Blackhawk," "BX-15," "BX-25," Eagle 'R' - soft 'R' & hard 'R', Eagle 'SR', "Everything you need and nothing you don't," "GP100," "Hawkeye," "It's Mine and It's American," "It's Mine. And It's American," "LC380," "LC9," "LC9s," "LC9s Pro," "LCP," "LCR," "LCRx," "M77," "Mini Thirty," "Mini-14," "9E," "Old Army," "Power Bedding," "Redhawk," "RUGER," "Ruger American Pistol," "Ruger American Pistol" flag design, "Ruger American Rifle," "Ruger American Rimfire," "Ruger Hunting" - phrase & logo design, "Ruger Inside & Out" - phrase & logo design, "Ruger Precision Rifle," "Ruger 77/17," "Ruger 77/22," "Ruger 77/44," "Ruger SP101," "Ruger 10/22 Takedown" phrase & logo design, "Ruger 22/45 Lite," "Ruger Vaquero," "Rugged, Reliable Firearms," "Security-9," "Silent-SR," "Single-Nine," "Single-Six," "Single-Ten," the "SR" Design, "SR9," "SR9c," "SR40," "SR40c," "SR-22," "SR22," "SR-556," "SR-556E," "SR-556 Takedown," "SR1911," "Super Redhawk Alaskan," and "10/22."