

RYOBI 10 in. (254 mm) TABLE SAW

MODEL NO. BT3100

REPAIR SHEET

RYOBI 10 in. (254 mm) TABLE SAW - MODEL NO. BT3100

FOR MITER TABLE ASSEMBLY,
REFER TO FIGURE B

FOR BLADE GUARD ASSEMBLY,
REFER TO FIGURE E

FOR RIP FENCE ASSEMBLY,
REFER TO FIGURE C

FOR MOTOR ASSEMBLY,
REFER TO FIGURE D

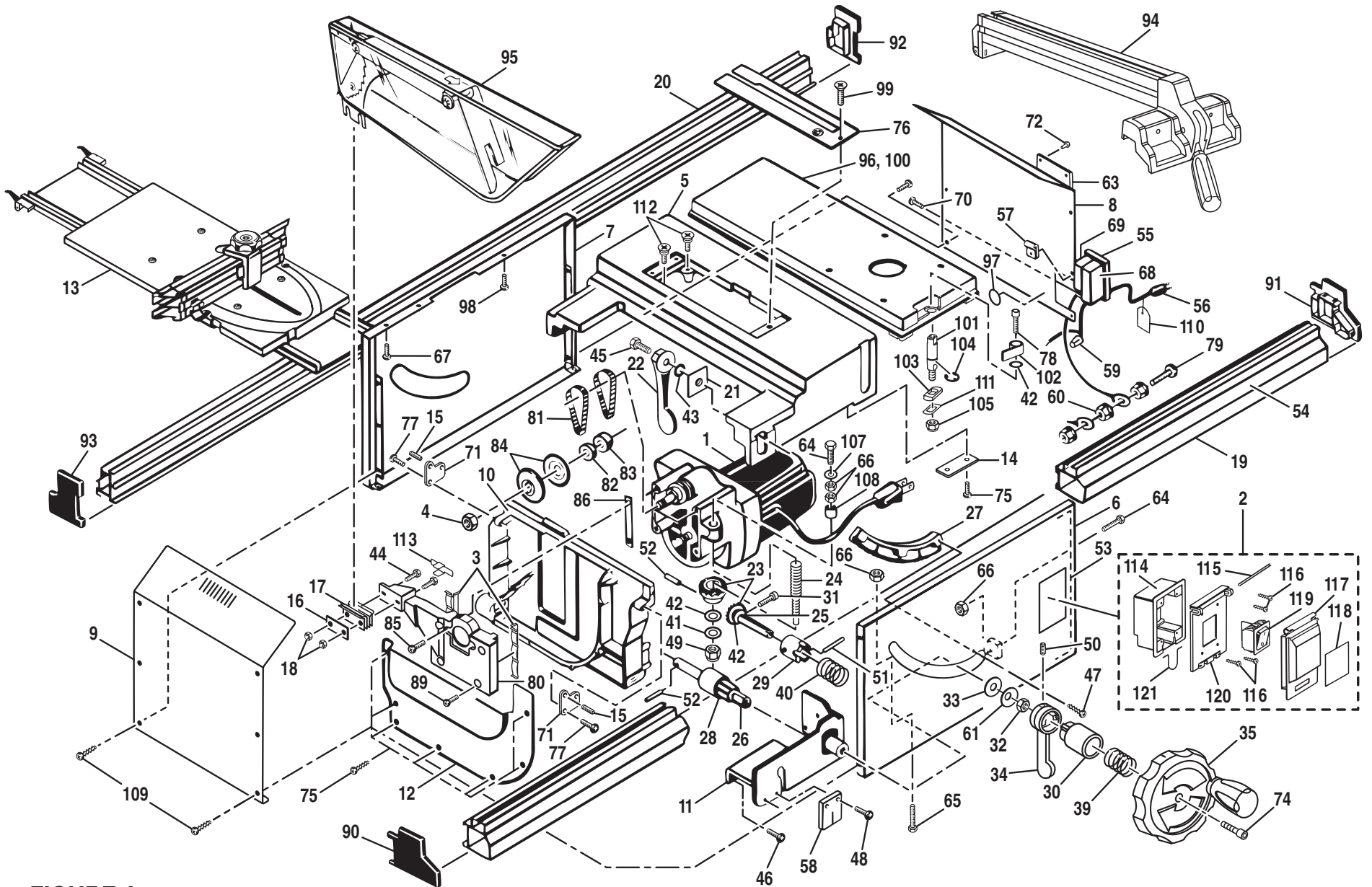

FIGURE A

RYOBI 10 in. (254 mm) TABLE SAW - MODEL NO. BT3100

PARTS LIST - FIGURE A

The model number will be found on the data plate attached to the right side panel of the cabinet, next to the saw's on board receptacle. Always mention the model number in all correspondence regarding your **TABLE SAW** or when ordering repair parts.

KEY PART NO. NO.	DESCRIPTION	QTY.	KEY PART NO. NO.	DESCRIPTION	QTY.		
1	969214-010	MOTOR ASSEMBLY.	1	44	615570-007	HEX BOLT (5/16-18 X 1-1/8 in.) ..	2
2	664106-001	OFF/ON SWITCH ASSEMBLY	1	45	615570-020	HEX BOLT (5/16-18 X 3/4 in.).....	4
3	0181010314	SHIM.....	2	46	968705-009	SCREW (10-24 X 5/8 in. PAN HD.).....	8
4	969226-001	HEX NUT (5/8-18).....	1	47	662493-002	SCREW (10-24 X 5/8 in. PAN HD.).....	3
5	0181010111-94	SAW TABLE	1	48	968703-005	SCREW (8-32 X 3/8 in. PAN HD.).....	16
6	0181010326-94	FRONT CABINET PANEL.....	1	49	607406-005	NYLON HEX NUT (3/8-16)	1
7	0181010328-94	REAR CABINET PANEL.....	1	50	969218-001	SET SCREW (1/4-20 X 3/8 in.)	1
8	0181010327-94	RIGHT CABINET PANEL.....	1	51	941401-018	ROLL PIN	1
9	0181010329-94	LEFT CABINET PANEL	1	52	941401-831	ROLL PIN	2
10	0181010106	LOCKER BRACKET	1	53	9181015330101	NAME PLATE.....	1
11	661694-003	CLAMPER BRACKET	1	54	9181015330301	SCALE LABEL.....	1
12	0181010316	DUST COVER	1	55	969137-001	OUTLET (15 AMP SINGLE POLE).....	1
13	A181010802	MITER TABLE ASSEMBLY.....	1	56	969138-001	CORD	1
14	969113-001	CLAMP PLATE.....	2	57	989001-001	CABLE CLAMP	1
15	623924-002	NEEDLE ROLLER (1/4 in. X 3/4 in.).....	2	58	969140-001	BEVEL INDICATOR.....	1
16	662481-001	CLAMP	1	59	623173-007	WIRE NUT	1
17	0181010343	SHIM.....	5	60	643128-001	LOCK NUT (8-32 HEX)	3
18	607406-003	HEX NUT (5/16-18).....	2	61	969142-001	CONE DISC SPRING.....	1
19	0181010812	FRONT RAIL	1	63	9181015332201	DATA PLATE	1
20	0181011805	REAR RAIL.....	1	64	615570-012	BOLT (1/4-20 X 1 in. HEX).....	2
21	969251-002	RAIL HOLDER NUT (5/16)	4	65	615570-011	BOLT (1/4-20 X 2 in. HEX).....	1
22	663144-001	RAIL LOCKING CLAMP.....	4	66	622171-053	HEX NUT (1/4-20).....	4
23	969122-002	BEVEL GEAR.....	2	67	968705-004	SCREW (10-24 X 5/16 in. PAN HD.).....	2
24	969123-001	SHAFT	1	68	969230-001	PLUG SOCKET BOX (A).....	1
25	969124-001	GEAR SHAFT.....	1	69	969229-001	PLUG SOCKET BOX (B).....	1
26	969125-002	HANDLE SHAFT	1	70	968702-011	SCREW (8-16 X 3/4 in. PAN HD.).....	4
27	969126-001	GEAR RACK	1	71	664087-001	LOCKER SUPPORT	2
28	969127-001	TILTING GEAR	1	72	0181010923	RIVET.....	4
29	969128-001	CLUTCH	1	73	662079-001	SET SCREW (10-24 X 3/8 in.)	4
30	969129-002	CAM.....	1	74	410151710	CAP SCREW	1
31	998292-002	SCREW (8-32 X 1-3/16 in. FIL. HD.).....	1	75	968705-040	SCREW (10-24 X 1/2 in. PAN HD.).....	11
32	607406-006	HEX NUT (3/4-16).....	1	76	0181010342	THROAT PLATE.....	1
33	661796-001	WASHER.....	1	78	969220-002	CAP SCREW	1
34	969130-001	BEVEL LOCKING LEVER.....	1	79	0181010816	GROUND SCREW.....	1
35	A181014002	BLADE ADJUSTING HANDLE	1	80	0181010110	GUIDE HOLDER.....	1
39	969222-001	SPRING	1				
40	969221-001	SPRING	1				
41	706382-359	WASHER.....	1				
42	706382-360	WASHER.....	3				
43	706382-346	WASHER.....	4				

RYOBI 10 in. (254 mm) TABLE SAW - MODEL NO. BT3100
PARTS LIST - FIGURE A (CONT'D)

KEY PART NO.	NO.	DESCRIPTION	QTY.	KEY PART NO.	NO.	DESCRIPTION	QTY.
81	662329-001	V BELT.....	2	102	969175-002	HANDLE.....	1
82	662062-001	1/4 in. SPACER	1	103	969216-001	SPRING PLATE.....	1
83	662062-002	1/2 in. SPACER	1	104	623111-001	RETAINING EXTENSION.....	1
84	969205-001	BLADE WASHER.....	2	105	644585-002	HEX NUT (1/4-20).....	1
85	614658-007	SCREW (8-32 X 3/4 in. PAN HD.).....	3	107	706382-343	WASHER.....	1
86	969600-001	SHIM	2	108	661853-001	SPACER.....	1
89	968705-015	SCREW (10-24 X 1 in. PAN HD.).....	4	110	663339-001	HANG TAG.....	1
90	0181010241	END PLUG F1 (FRONT LEFT)	1	111	661992-002	BACK-UP PLATE	1
91	0181010242	END PLUG F2 (FRONT RIGHT) ..	1	112	0181010813	SCREW (10-24 X 3/4 in. FLAT HD.).....	2
92	0181010236	END PLUG R1 (RIGHT REAR)	1	113	662080-001	BOLT HOLDER	1
93	0181010237	END PLUG R2 (LEFT REAR)	1	114	663284-001	REAR SWITCH COVER	1
94	A181010901	RIP FENCE ASSEMBLY	1	115	623924-009	NEEDLE ROLLER	1
95	969165-001	BLADE GUARD ASSEMBLY	1	116	968702-005	SCREW (8-16 X 3/8 in. PAN HD.).....	4
96	A181012002	* ACCESSORY TABLE ASSEMBLY.....	1	117	663283-001	SWITCH COVER.....	1
97	9181015335701	GROUNDING LABEL	1	118	664105-001	SWITCH COVER LABEL.....	1
99	410101012	SCREW (FLAT HD.).....	1	119	664104-001	SWITCH	1
100	0181010102-94	ACCESSORY TABLE.....	1	120	663285-001	SWITCH BASE.....	1
101	969174-004	HANDLE SHAFT.....	1	121	664084-001	LATCH.....	1

* Item 96 includes parts 42, 78, 100 through 106, and 111.

RYOBI 10 in. (254 mm) TABLE SAW - MODEL NO. BT3100
FIGURE B: SLIDING MITER TABLE ASSEMBLY

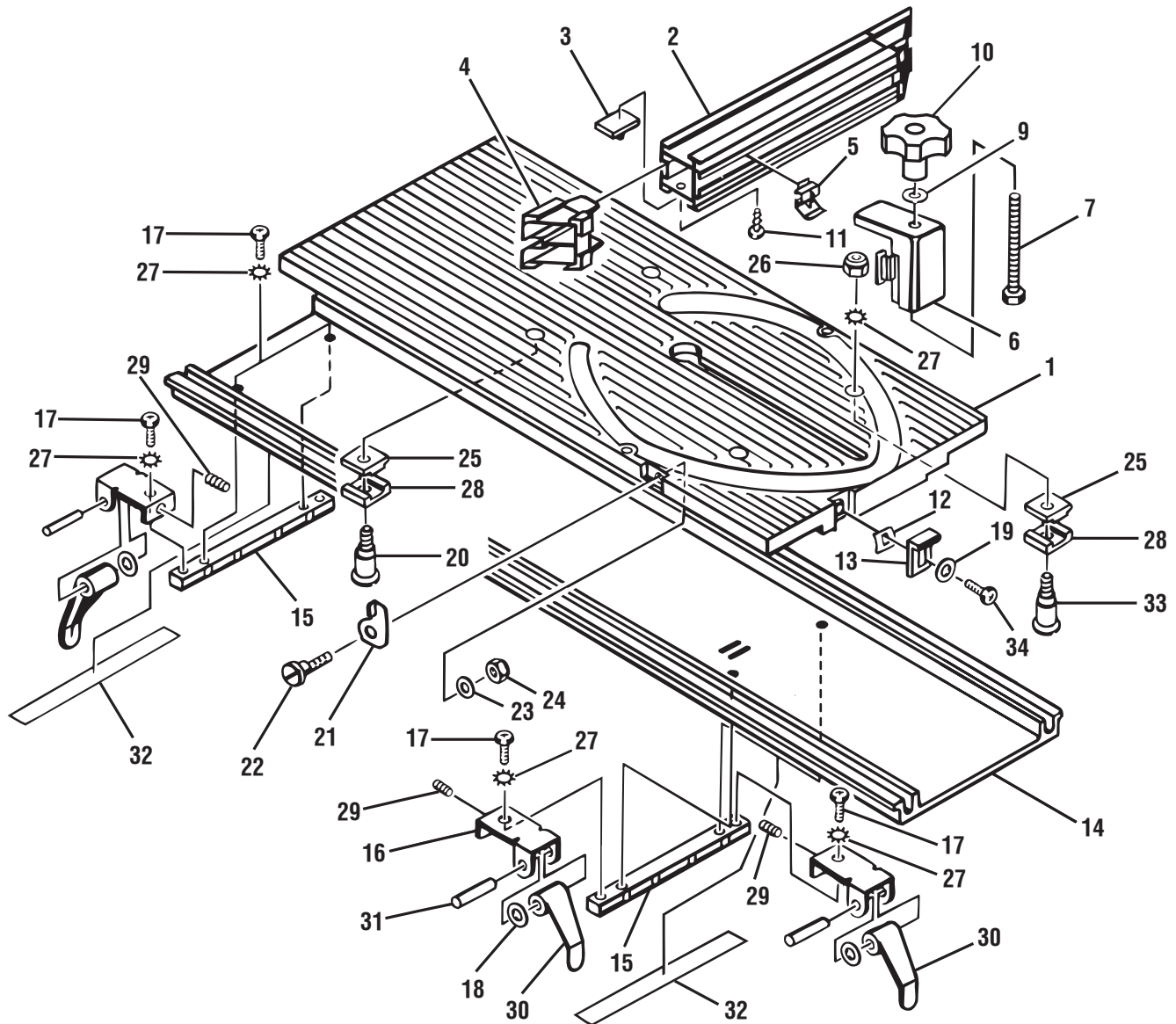

KEY NO.	NO.	PART DESCRIPTION	QTY.	KEY NO.	NO.	PART DESCRIPTION	QTY.
1	0181010101-94	MITER TABLE TOP	1	18	607617-003	O-RING.....	4
2	969188-001	MITER FENCE	1	19	621721-010	WASHER	1
3	661811-001	PIVOT.....	1	20	969502-001	ECCENTRIC SCREW (10-24).....	3
4	969190-001	SAW GAGE	2	21	969500-001	QUICK STOP.....	1
5	969191-002	MITER INDICATOR	1	22	969501-002	ECCENTRIC SCREW (8-32).....	1
6	969192-001	MITER FENCE HOLDER.....	1	23	621721-001	WASHER	1
7	615570-010	BOLT (5/16-18 X 3-1/4 in. HEX HD.).....	1	24	703477-006	HEX NUT (ELASTIC STOP)	1
9	706382-357	WASHER.....	1	25	661844-001	SLIDE (A)	4
10	662285-001	ADJUSTING CLAMP.....	1	26	703477-059	HEX NUT (ELASTIC STOP)	4
11	968702-009	SCREW (8-16 X 5/8 in. PAN HD.)	2	27	621032-001	LOCK WASHER	12
12	969227-001	SPRING PLATE	1	28	661845-001	SLIDE (B)	4
13	969225-001	MITER SLIDE LOCK.....	1	29	969218-005	SET SCREW (10-24 X 1/4 in. HEX SOCKET).....	4
14	969228-003	MITER BASE	1	30	969915-002	MITER LOCKING CLAMP	4
15	664137-001	GUIDE BAR	2	31	941401-308	ROLL PIN	4
16	969916-006	HOLDER PLATE.....	4	32	661706-001	GUIDE PLATE.....	2
17	968705-041	SCREW (10-24 X 15/32 in. PAN HD.)	8	33	662306-001	NON-ECCENTRIC SCREW (10-24)	1
				34	968705-007	SCREW (10-24 X 1/2 in. PAN HD.).....	1

RYOBI 10 in. (254 mm) TABLE SAW - MODEL NO. BT3100
FIGURE C: RIP FENCE ASSEMBLY

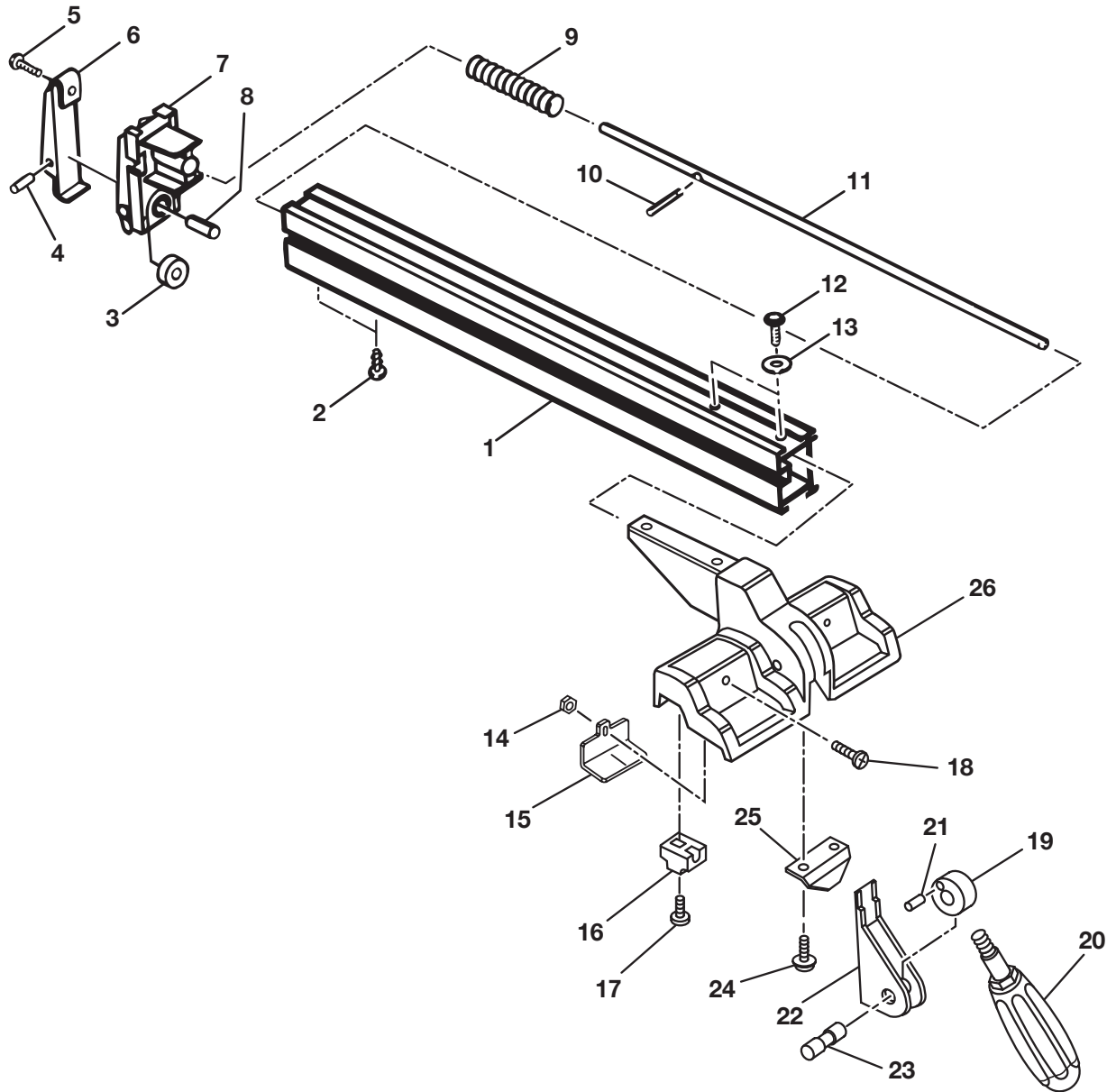

KEY NO.	PART NO.	DESCRIPTION	QTY.	KEY NO.	PART NO.	DESCRIPTION	QTY.
1	969144-001	RIP FENCE	1	14	706404-007	HEX NUT (8-32)	1
2	968704-006	SCREW (10-14 X 1/2 in. PAN HD.)	2	15	0181010243	SCALE INDICATOR	1
3	969155-001	FENCE ROLLER	1	16	969240-001	SLIDE	2
4	941401-309	ROLL PIN	1	17	968703-007	SCREW (8-32 X 1/2 in. PAN HD.)	2
5	607067-007	SCREW (10-24 X 1 in. PAN HD.)	1	18	410131719	SCREW	1
6	969254-001	CLAMPER - B	1	19	969146-003	ECCENTRIC ROLLER	1
7	969154-002	ROLLER HOLDER	1	20	A181010227	LOCKING HANDLE	1
8	969114-001	DOWEL PIN (1/4 in. X 3/4 in.)	1	21	623019-004	RUBBER PLUG	1
9	969253-001	COMPRESSION SPRING	1	22	969252-001	CLAMPER - A	1
10	941401-833	ROLL PIN	1	23	969147-002	PIN	1
11	969156-001	ROD	1	24	968703-005	SCREW AND WASHER	2
12	610878-003	SCREW (1/4-20 X 5/8 IN. BUTTON HD.)	2	25	969150-001	PLATE	1
13	706382-358	WASHER	2	26	0181010115-58	FRONT BLOCK	1

RYOBI 10 in. (254 mm) TABLE SAW - MODEL NO. BT3100

FIGURE D: MOTOR ASSEMBLY

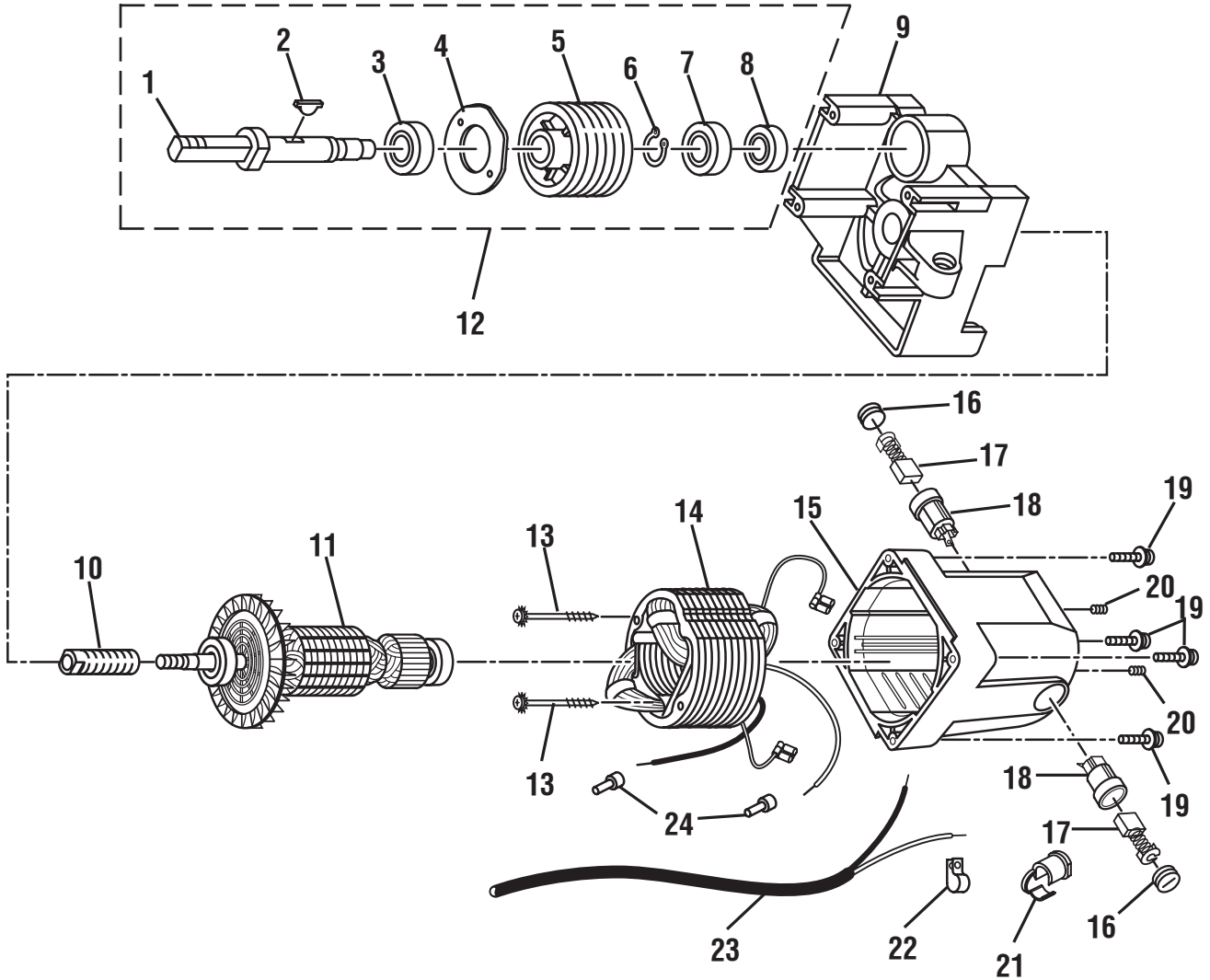

KEY NO.	PART NO.	DESCRIPTION	QTY.	KEY NO.	PART NO.	DESCRIPTION	QTY.
1	969209-001	ARBOR.....	1	13	4130268	SCREW AND WASHER (FIELD PAN HD.)	2
2	616452-010	WOODRUFF KEY (3/16 in.)....	1	14	4500008	FIELD ASSEMBLY.....	1
3	969235-003	BALL BEARING (6003).....	1	15	4800030	MOTOR HOUSING	1
4	969203-001	BEARING PLATE.....	1	16	4570009	BRUSH COVER	2
5	969210-002	ARBOR PULLEY	1	17	4540007	BRUSH ASSEMBLY.....	2
6	622167-068	RETAINING RING.....	1	18	4570008	BRUSH HOLDER ASSY.	2
7	969235-004	BALL BEARING (6002).....	1	19	4130267	SCREW AND WASHER (PAN HD.).....	4
8	969235-005	BALL BEARING (6200ZZ)	1	20	4130266	SET SCREW (HEX).....	2
9	4800031	MOTOR BRACKET	1	21	4520017	STRAIN RELIEF BUSHING	1
10	4860022	MOTOR PULLEY	1	22	4520018	CABLE CLAMP	1
11	4460008	ARMATURE ASSEMBLY.....	1	23	4520016	POWER CORD.....	1
12	A181010501	ARBOR ASSEMBLY (JACKSHAFT ASSEMBLY)....	2	24	4560026	CONNECTOR	2

RYOBI 10 in. (254 mm) TABLE SAW - MODEL NO. BT3100
FIGURE F: BLADE GUARD ASSEMBLY

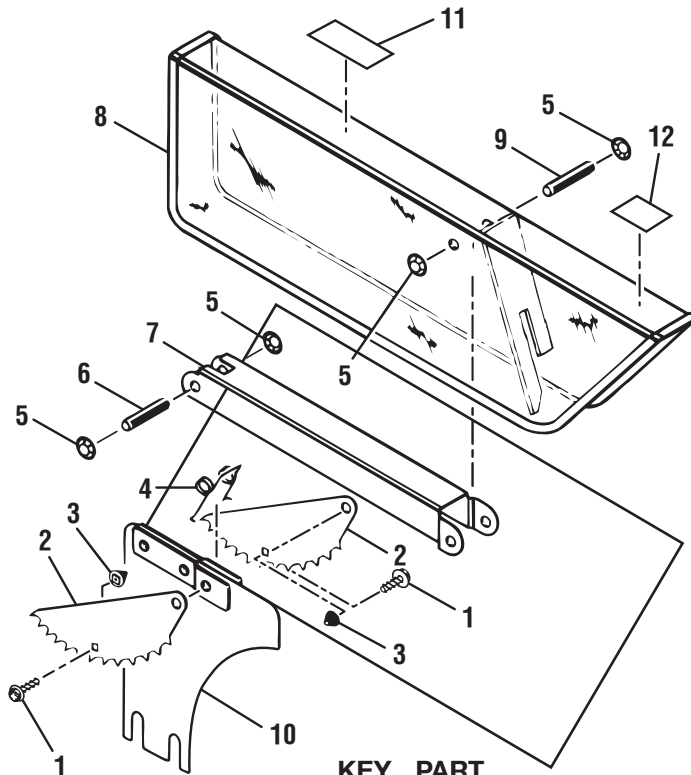

KEY NO.	PART NO.	DESCRIPTION	QTY.	KEY NO.	PART NO.	DESCRIPTION	QTY.
7	969610-002	ARM.....	1	1	968700-004	SCREW AND WASHER.....	2
8	969612-001	COVER	1	2	969169-001	ANTI-KICKBACK FINGERS.....	2
9	969170-002	DOWEL PIN	1	3	662002-001	SPACER CAP	2
10	969168-005	RIVING KNIFE ASSEMBLY.....	1	4	969608-001	TORSION SPRING	1
11	9181015330201	WARNING LABEL.....	1	5	969233-010	PUSH NUT	4
12	9181015330202	HAND WARNING LABEL.....	1	6	969170-001	DOWEL PIN.....	1

FIGURE F: REPLACEMENT PARTS

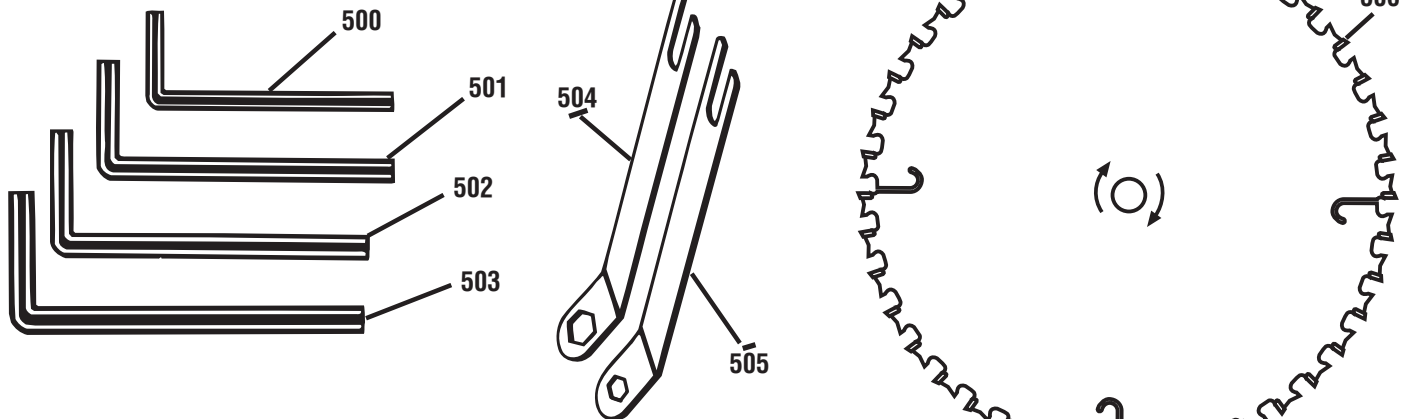

KEY NO.	PART NO.	DESCRIPTION	QTY.	KEY NO.	PART NO.	DESCRIPTION	QTY.
500	820193-004	3/32 IN. HEX KEY.....	1	504	969244-003	LARGE WRENCH.....	1
501	820193-005	1/8 IN. HEX KEY.....	1	505	969244-004	SMALL WRENCH.....	1
502	820193-006	5/32 IN. HEX KEY.....	1	506	969196-001	SAW BLADE.....	1
503	820193-007	3/16 IN. HEX KEY.....	1				

RYOBI 10 in. (254 mm) TABLE SAW - MODEL NO. BT3100

The model number will be found on the data plate attached to the right side panel of the cabinet, next to the saw's on board receptacle. Always mention the model number in all correspondence regarding your **TABLE SAW** or when ordering repair parts.

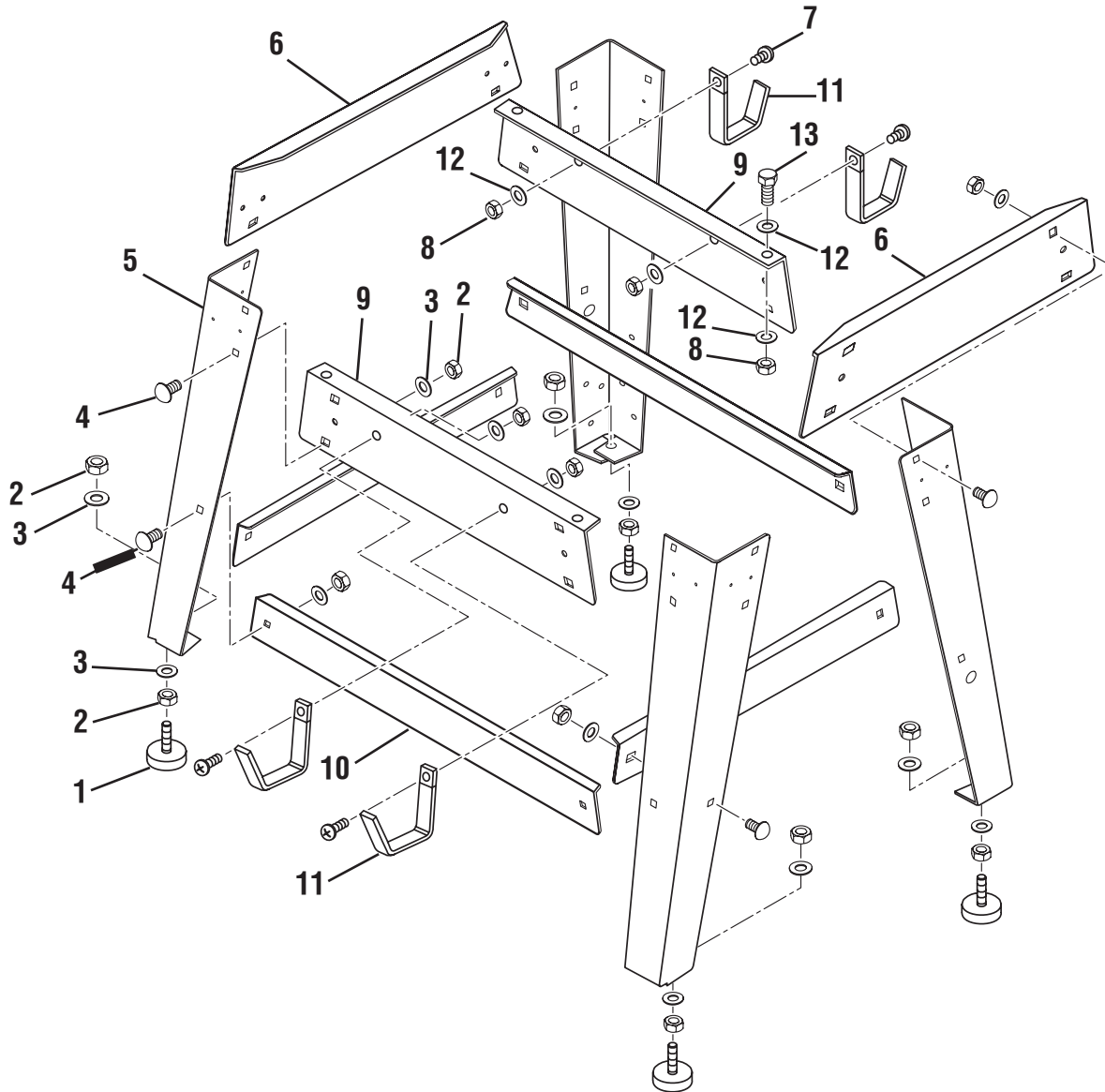

FIGURE G

RYOBI 10 in. (254 mm) TABLE SAW - MODEL NO. BT3100

The model number will be found on the data plate attached to the right side panel of the cabinet, next to the saw's on board receptacle. Always mention the model number in all correspondence regarding your **TABLE SAW** or when ordering repair parts.

PARTS LIST FOR FIGURE G

KEY NO.	PART NO.	DESCRIPTION	QTY.
1	0181010238	LEVELING FOOT	4
2	411011710	HEX NUT	32
3	412011067	WASHER	32
4	410031704	CARRIAGE BOLT.....	24
5	0181010338-94	LEG.....	4
6	0181010335-94	UPPER BRACE.....	2
7	410131722	SCREW.....	4
8	411011707	HEX NUT	8
9	0181010336-94	UPPER SIDE BRACE.....	2
10	0181010337-94	LOWER BRACE.....	4
11	0181010334	STORAGE BRACKET	4
12	412011069	WASHER	12
13	410011710	BOLT.....	4
	A181011501	STAND FASTENER ASSEMBLY (NOT SHOWN)	1
	983000132	OPERATOR'S MANUAL	
	2-01-08 (REV:01)		