



Weaver

CONSTRUCTION MANAGEMENT

3679 S Huron Street, Suite 404 Englewood, Colorado 80110
Phone: (303) 789-4111 FAX: (303) 789-4310

SUBMITTAL TRANSMITTAL

April 23, 2012

Submittal No: 06602-002

PROJECT: **Harold Thompson Regional WRF**
Birdsall Rd.
Fountain, CO 80817
Job No. 2908

ENGINEER: **GMS, Inc.**
611 No. Weber St., #300
Colorado Springs, CO 80903
719-475-2935 Roger Sams

OWNER: **Lower Fountain Metropolitan
Sewage Disposal District**
901 S. Santa Fe Ave.
Fountain, CO 80817
719-382-5303 James Heckman

CONTRACTOR: **Goble Sampson Associates**
2460 W 26th Ave, 30-C
Denver, CO 80211
303-770-6418 Josh Queen
jqueen@goblesampson.com

SUBJECT: Plasti-Fab Parshall Flume @ P&D Building

SPEC SECTION: 06602

PREVIOUS SUBMISSION DATES:

DEVIATIONS FROM SPEC: ___ YES X NO

CONTRACTOR'S STAMP: This submittal has been reviewed by Weaver Construction Management and, unless indicated otherwise, has been found to be in conformance with the intent of the contract documents.

Contractor's Stamp:

Engineer's Stamp:

Date: 4/23/12

Reviewed by: John Jacob

(X) Reviewed Without Comments
() Reviewed With Comments

ENGINEER'S
COMMENTS: _____



PARSHALL
FLUMES



PALMER-BOWLUS
FLUMES



TRAPEZOIDAL
FLUMES

FLOW MEASUREMENT PRODUCTS



H-FLUMES



PACKAGED
METERING
MANHOLE



MAG METER
MANHOLE

Over 40 years of excellence in engineering and fabricating composite flow measurement products. Plasti-Fab flow measurement products have a 25 year corrosion warranty.

PLASTI-FAB FLUMES

Plasti-Fab was a leader in the flume fabrication revolution that began over forty years ago and has thousands of flumes working in corrosive environments around the world. All Plasti-Fab flumes have precise throat dimensions for accurate flow measurement, and are coated with a premium grade isophthalic gel coat providing a smooth non-porous surface for enhanced flow passage and long-term UV protection. Head gages for visual fluid level checking are standard on all flumes.

PARSHALL FLUMES

Plasti-Fab Parshall Flumes have a wide flow range, providing the ability to capture variable low and peak flow readings in a single flume. The Parshall Flume standard sizes range from 1-inch to 15-foot throats and provide great resolution.



PARSHALL FLUME WITH INLET ADAPTERS TO FIT A ROUND BOTTOM CHANNEL.

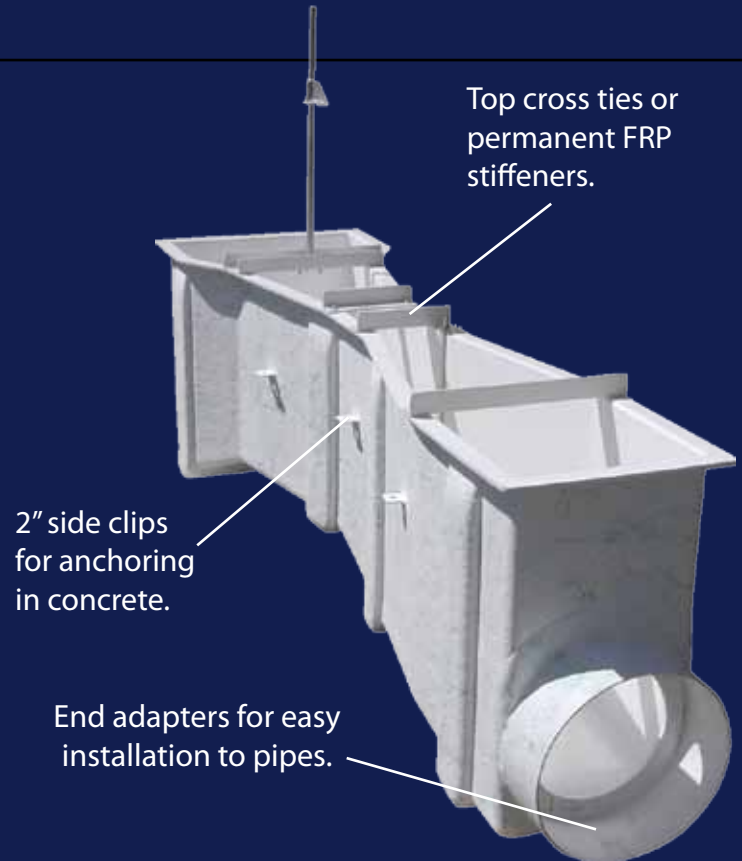

PALMER-BOWLUS FLUMES

Plasti-Fab Palmer-Bowlus Flumes have wide throats and short lengths, making them ideal for pipe hookups. Palmer-Bowlus Flumes are economical and easy to install in manholes and pipelines. Palmer-Bowlus flumes range from 4-inch to 6-foot throat sizes and have a high submergence tolerance.



Plasti-Fab is internationally known for experience and expertise in providing solutions for simple to complex issues involving design and installation requirements.

PLASTI-FAB FLUMES

TRAPEZOIDAL FLUMES

Plasti-Fab Trapezoidal Flumes are low profile and provide excellent low-flow resolution. Trapezoidal Flumes offer the ability to provide repeatable accurate measurements in flows down to 1 GPM to meet stringent requirements. The Trapezoidal Flumes are available in eight standard sizes.



Plasti-Fab Trapezoidal Flumes are available in a variety of configurations and have many accessory options.

H-FLUMES

Plasti-Fab H-Flumes can accommodate the widest range of flow and have a high tolerance for velocity. The H-Flumes have a usable range of more than 100:1, making them ideal for applications such as storm water measurement. The H-Flumes standard sizes range from 0.4 to 4.0 feet.



FLUME CUSTOMIZATION

Some standard options for flumes include:

- Inlet and Outlet Adapters
- Wingwalls and Bulkheads
- Pipe Stubs or Caulking Collars
- Slip Flanges
- Neoprene Boots with S/S Bands
- End Walls for Approach
- Bubble Pipes
- Sample Pipes
- Sonic Mounting Brackets
- Stilling Wells
- pH Probe Lift-Out Brackets
- Capacitance Probe Side Cavities
- Pressure Transducer Cavities
- Threaded Taps
- Two Vial Bubble Levels
- Temperature Probes with Lift-Out Brackets
- Nested, Insert, and Staged Flumes
- Magic Bottoms
- Access Boxes
- Tranquilizing Racks

THE PLASTI-FAB LEGACY

Plasti-Fab is a world class manufacturer of composites with over 40 years of experience designing, engineering and building products for fluid management and control. Plasti-Fab products are fabricated from highly corrosion resistant composite fiberglass reinforced plastic (FRP). Recognized around the world as an experienced innovator and provider of quality composite solutions, Plasti-Fab has a wealth of experience and expertise in flow measurement products.

Visit us online at: www.plasti-fab.com

FLOW MEASUREMENT MANHOLES

Plasti-Fab Packaged Metering Manholes (PMMs) are watertight one-piece construction with an integral bottom. They weigh only a fraction of comparable concrete or steel manholes and are extremely resistant to chemicals, saltwater, corrosive soils, ground water and electrolysis. Manhole bottoms are a dual-layer construction to prevent oil canning and provide a flat installation surface.

Packaged Metering Manhole tops may be designed for steel covers to meet H-20 highway loading, or with hinged FRP lids and lockable hasps, or with aluminum hatches for water/gas tight applications, or completely customized. The PMM interior is premium

isophthalic white gel coat that provides a smooth non-porous surface to resist bacteria for a cleaner workspace and to allow for maximum illumination.

All hardware is heavy-duty stainless steel. Anchor tabs are mechanically fastened to the barrel to ensure a secure installation. Pipe stubs are built to match the ID and OD of the mating pipe. Invert elevations can be adjusted to meet the elevation of the pipe in the field. PMMs may be completely customized with a full range of accessories.

Standard options include FRP Ladders, Ladder Lifts, Head Deflectors, Threaded Taps, Shelves, FRP Grating, Pulleys, Vents and Fans.

PACKAGED METERING MANHOLES

The Plasti-Fab Packaged Metering Manhole, an industry first, is an integral solution to underground flow measurement needs. The PMM reduces installation errors and installation time. PMMs are available with any size flume by locating the barrel over the measuring point. The PMM offers contractors, engineers, and municipalities, peace of mind knowing that the professionally installed integral flume provides maximum accuracy of flow measurement in a long lasting, water-tight and sanitary operating environment.



MAG METERING MANHOLES

The Plasti-Fab Mag Meter Manhole (MMM) is an integrated solution for closed pipe flow measurement needs. The Mag meter is installed within the manhole barrel, providing a clean, dry, leak proof environment. The Plasti-Fab MMM is engineered for high pressure water lines and includes bolting flanges for attachment of the mag meter. Plasti-Fab will factory install customer furnished mag meters.

Mag Meters and other devices may be professionally installed at the factory



PLASTI-FAB INC.
PO Box 100
Tualatin, Oregon 97062-0100
(503) 692-5460
sales@plasti-fab.com
www.plasti-fab.com

Contact Your Local Plasti-Fab Representative
<http://www.plasti-fab.com/fiberglass-manufacturing-representatives>



INSTALLATION INSTRUCTIONS NESTED PARSHALL FLUMES

Flumes shall be installed level end-to-end and side-to-side by using a level on the floor of the inside flume.

1. Flumes must be cribbed or shored up inside in order to keep the sidewalls plumb and maintain the dimensional integrity of the flume. The throat is the most critical portion of the flume to protect. For Nested flumes this may be accomplished by shoring up the inside flume and bracing the larger flume in one of the following manners.

Carefully placing spacer blocks between the walls of the two flumes, or . . .

Fill the space between the walls with sand. (This can be capped with a 2" - 3" grout layer after installation is complete.), or

Fill the space with water. (During installation concrete must be placed in 6" to 10" lifts. See Note 6 below)

2. The top cross ties should be left on the flume until it has been installed. If the flume is set in concrete the cross ties can be removed if desired. Wood cross ties are not intended for permanent installation.

3. Cross beams are suggested for the leveling of the flume, prevention of floating and limiting shifting of the flume during the grouting process. These cross beams will span the channel and attach to each of the side channel walls. Then drill through the top flange of the flume and bolt to these beams. Double nut or shim to get the flume set level both directions. Other cross bracing may be required to prevent shifting. It may be desirable to do cross bracing near or at the bottom of the flume.

NOTE: Flumes must remain level both directions.

4. Secure the 2" x 2" angle clips on flume to rebar with No. 8 wire or put rebar through the clips to key the flume into the concrete. (Concrete does not bond well to fiberglass). The 2" x 2" angle clips are not made for leveling or to prevent shifting.

5. Plasti-Fab flumes are designed to be free standing, and require no additional external support in order to maintain their dimensional integrity during operation. However they need to have the bottom adequately supported to be keep the flume and the floor level. This is especially true for flumes having a throat width of 12" or more.

6. The flume is commonly grouted into an existing concrete channel. This allows for the crossbeams (see # 3 above) to be used. Grouting into an existing channel is the preferred method of installation. Pouring the concrete or grout around the flume to fast can deform the sides/floor of the flume, force it to shift out of alignment or make it out of level. Great care must be taken if a vibrator is used. It can also cause distortion. Proper bracing/cribbing is important (see #1 above).

NOTE: When installing a flume we would recommend that concrete or grout be poured in layers of not more than 6”- 10” at a time and each layer be allowed to take a set before the next is added.

7. A long flared inlet transition should be made from the inlet of a flume upstream to the approach channel or pipe. This is to smoothly transition or “funnel” the flow from the shape and size of the inlet channel to the shape and size of the flume.

Flow must be non-turbulent and have a low approach velocity. An outlet transition may also be required to help the flow return smoothly back into a pipe so the flow doesn’t back up into the flume.

8. Not Used - *All flumes with bolt on adapters, caulking collars or transition sections must be sealed between joints. We suggest applying one or two continuous bead(s) of silicone on all seating surfaces between flanged joints before bolting together.*

Please note for flumes which are being installed by using caulking collars in an existing pipe line; the length of pipe to cut out should be 1” to 2” longer than the measurement from the inside wall of the inlet adapter to the inside wall of the outlet adapter. Cut out the pipe. Slip each caulking collar over the pipe. Bolt and seal the flume between the caulking collars. Align the hole through the wall of the adapter with the pipe hole. Pack the area in the caulking collar between the outside of the pipe and the inside of the caulking collar with oakum, grout or some other type of packing. (This does not need to be leak proof if the flume will be encased in concrete.) Then level and brace the flume as noted above.

9. Not Used - *An inlet adapter should have a ramped floor for transitioning flows up to the floor of the flume. This will help transition solids and help facilitate a nonturbulent flow into the flume. Some of our adapters have a built in ramp from the floor of the adapter to the floor of the flume. If your inlet adapter does not have a built in ramp, you will need to grout a ramp from the inlet pipe invert to the floor of the flume. At times, even an inlet adapter with a built in ramped floor, may be better off having additional grouting added if the inlet pipe is set more than 2” off the floor of the adapter. This again will maximize transitioning solids and assist in creating a nonturbulent flow.*

10. Not Used - *60” Parshall flumes (or larger) have steel tubes laminated to the floor of the flume. These tubes may also be used to secure the flume in place and level it. For wide spans extra support may be required under the flume to keep the floor flat and level.*

ADDITIONAL NOTES: The interior flume and nesting hardware has been pre-installed at the factory and all joints have been sealed. When this flume is level both flumes should be level. If for any reason the inner flume is removed and must be reinstalled/nested -

Place the flume to be nested so that the flat section of the throat rests evenly on the throat of the larger unit.

The leading edge of the throat section on both flumes should be aligned. (See print.)

Position and level the inner flume so that it matches the pre-drilled mounting holes. Apply a bead of silicon or other watertight sealant to the flange, bulkhead and other contacting surfaces of the insert flume. Bolt into place using 3/8" stainless steel anchor bolts or lag bolts.

If desired, the space between the sidewalls of the two flumes may be filled with sand and covered with a layer of breakable grout to help prevent collection of water between the flumes.

Installation Comments: The flow coming into the flume must be non-turbulent and have a low approach velocity. Consult factory if you have steep slope, pumping, tank dumping, vertical drop or are uncertain as to acceptable slopes and velocities for your installation. Downstream of the flume the flow must get away from the flume. To this end the channel or pipe must be large enough and have enough slope or drop to take the flow away from the flume with out creating back water submergence. At times an outlet transition may also be required to help funnel the flow smoothly back into a pipe. This would be to help prevent the flow from backing up into the flume.

Parshall: The outlet of the flume is best suited to be higher than the outlet pipe (or channel) to help get the flow away from the flume. This is especially important when reentering a pipe that is running more than 75 % full.

The inlet of the flume may be at the same elevation as the inlet pipe or channel, but is commonly set higher. A ramp should be grouted to this higher elevation at a 4:1 slope to help transition solids through the flume. At no time should the inlet pipe or channel be set higher than the inlet floor of the flume.

If you support the interior adequately, take your time and keep in mind the above suggestions, you should have a successful installation.

Please consult your local representative or contact Plasti-Fab, Inc., PO Box 100, Tualatin, Oregon, 97062.

PHONE 503-692-5460 **FAX** 503-692-1145 **E-MAIL** SALES@PLASTI-FAB.COM **WEB** WWW.PLASTI-FAB.COM



PARSHALL FLUME RECEIVING AND STORAGE SUGGESTIONS

GENERAL

This covers the full range of flumes manufactured by Plasti-Fab. Therefore, some information may not be applicable to your particular installation. Please reference this information with that in mind.

RECEIVING

Check/Count all parts when you receive shipment. All individually shipped parts or assemblies are listed on packing list. Should a shortage exist, notify Plasti-Fab, Inc. immediately. We cannot be responsible for any shortages reported more than 30 days after receipt of shipment. Special care should be taken in accounting for and safely storing all bolts, nuts and small items, which can be misplaced at job sites.

Unless your contract with Plasti-Fab, Inc. states otherwise, all equipment is shipped f.o.b. factory. If any equipment has been damaged in transit, the purchaser will be responsible for filing a claim with the transportation company. For assistance in filing any claims and/or replacing equipment, please contact Plasti-Fab, Inc. directly.

HANDLING AND STORAGE

All Plasti-Fab flumes and accessories are precision parts that should be handled accordingly. While all parts are of rugged design, it is never the less possible to damage surfaces, etc., through improper storage and handling. To avoid all problems of this nature we recommend the following.

1. If flume(s) are too large to lift by hand, use spreader bar and canvas lifting straps around the flume to avoid scratching or damaging surfaces. Some very large or sectioned flumes have built-in half round lifting eyes for canvas lifting straps.
2. If flume(s) will not be installed immediately store equipment on a level, clean surface to prevent distortion. Flumes should be left on shipping skid and stored in upside down position.
3. Cover all equipment to protect surfaces.
4. DO NOT STACK EQUIPMENT.

Please contact Plasti-Fab if you have any questions.

Please consult your local representative or contact
Plasti-Fab, Inc., PO Box 100, Tualatin, Oregon, 97062.

PHONE 503-692-5460 **FAX** 503-692-1145

E-MAIL SALES@PLASTI-FAB.COM **WEB** WWW.PLASTI-FAB.COM



FLUMES: OPERATION AND MAINTENANCE SUGGESTIONS

The purpose of this manual is to provide information to the engineers, contractors, plant operators and associated personnel involved with installation, operation and maintenance of equipment supplied by Plasti-Fab, Inc. for this project. Although every care is taken in our factory to insure top quality, we cannot be responsible for damage caused by negligence during or after shipping. Herein are Plasti-Fab's recommendations for handling, storage, installation, and initial operation in standard situations. These suggestions should be used in conjunction with the approved installation drawings provided by Plasti-Fab, Inc. If proper care and accuracy are exercised in the field, the flume(s) will operate as designed at maximum efficiency.

Your Plasti-Fab flume is manufactured of fiberglass reinforced polyester (FRP) which includes a white pigmented interior layer of pure resin that is highly resistant to weathering, water and sewerage, detergents and acidic fluids. Under most conditions there should be no maintenance required. In some instances you may wish to wash the surface of the flume if it has become heavily coated with oil or various sludge buildups. In this case we suggest the use of water and a strong industrial detergent.

In operation, the flume acts as a restrictive venturi causing the water to dam up on the upstream end of the flume, thereby increasing flow velocity as it passes through the throat to the downstream channel. Measurement of the depth of the water in the upstream end of the flume provides a means by which the rate of flow may be determined from flow charts. Many flumes are equipped with instruments that monitor water depth and record the rate of flow on a chart. Please see the instrument manufacturer's manual for calibration and operating instructions on this equipment.

Proper operation and performance of the flume is based on:

1. Proper selection of the type and size of flume
2. Proper installation.
3. Flow entering the flume at subcritical velocity. High velocity is generally caused by excessive pipeline or channel slope, pumped flow, or a pressure head.
4. Flow surface being smooth, non-turbulent, in straight filaments.
5. Proper sizing of downstream conduit to take flow away from the flume.
6. Proper location and calibration of the flow instrument.

Since there are no moving parts or wearing surfaces in the flume, there are no further suggestions for maintenance of this device.

Please consult your local representative or contact Plasti-Fab, Inc., PO Box 100, Tualatin, Oregon, 97062.

PHONE 503-692-5460 **FAX** 503-692-1145 **E-MAIL** SALES@PLASTI-FAB.COM **WEB** WWW.PLASTI-FAB.COM



Flow Chart for 9” Parshall Flume

Head (feet)	MGD	CFS	GPM
0.06			
0.07			
0.08			
0.09			
0.10	0.05845	0.09060	40.662
0.11	0.06763	0.10483	47.046
0.12	0.07726	0.11975	53.745
0.13	0.08733	0.13535	60.747
0.14	0.09781	0.15161	68.040
0.15	0.10870	0.16848	75.616
0.16	0.11998	0.18597	83.463
0.17	0.13164	0.20404	91.575
0.18	0.14367	0.22269	99.944
0.19	0.15606	0.24190	108.56
0.20	0.16880	0.26165	117.43
0.21	0.18189	0.28193	126.53
0.22	0.19531	0.30272	135.86
0.23	0.20905	0.32403	145.42
0.24	0.22312	0.34583	155.21
0.25	0.23750	0.36812	165.21
0.26	0.25218	0.39088	175.43
0.27	0.26717	0.41412	185.86
0.28	0.28246	0.43781	196.49
0.29	0.29804	0.46196	207.33
0.30	0.31391	0.48656	218.37
0.31	0.33006	0.51159	229.60
0.32	0.34649	0.53705	241.03
0.33	0.36319	0.56294	252.65
0.34	0.38016	0.58925	264.46
0.35	0.39740	0.61597	276.45
0.36	0.41491	0.64310	288.63
0.37	0.43267	0.67064	300.98
0.38	0.45069	0.69857	313.52
0.39	0.46896	0.72689	326.23
0.40	0.48748	0.75560	339.11
0.41	0.50625	0.78469	352.17
0.42	0.52526	0.81416	365.40
0.43	0.54452	0.84401	378.79
0.44	0.56401	0.87422	392.35
0.45	0.58374	0.90480	406.08

Head (feet)	MGD	CFS	GPM
0.46	0.60371	0.93575	419.96
0.47	0.62390	0.96705	434.01
0.48	0.64433	0.99871	448.22
0.49	0.66498	1.0307	462.58
0.50	0.68585	1.0631	477.11
0.51	0.70695	1.0958	491.78
0.52	0.72827	1.1288	506.61
0.53	0.74981	1.1622	521.59
0.54	0.77156	1.1959	536.73
0.55	0.79353	1.2300	552.01
0.56	0.81571	1.2643	567.44
0.57	0.83810	1.2991	583.02
0.58	0.86070	1.3341	598.74
0.59	0.88351	1.3694	614.60
0.60	0.90652	1.4051	630.61
0.61	0.92974	1.4411	646.76
0.62	0.95316	1.4774	663.06
0.63	0.97678	1.5140	679.49
0.64	1.0006	1.5509	696.06
0.65	1.0246	1.5882	712.77
0.66	1.0488	1.6257	729.61
0.67	1.0733	1.6635	746.60
0.68	1.0979	1.7017	763.71
0.69	1.1227	1.7401	780.96
0.70	1.1476	1.7788	798.35
0.71	1.1728	1.8179	815.86
0.72	1.1982	1.8572	833.51
0.73	1.2237	1.8968	851.29
0.74	1.2495	1.9367	869.19
0.75	1.2754	1.9769	887.23
0.76	1.3015	2.0174	905.39
0.77	1.3278	2.0581	923.68
0.78	1.3543	2.0991	942.10
0.79	1.3809	2.1405	960.64
0.80	1.4078	2.1821	979.31
0.81	1.4348	2.2239	998.10
0.82	1.4620	2.2661	1,017.0
0.83	1.4893	2.3085	1,036.0
0.84	1.5169	2.3512	1,055.2
0.85	1.5446	2.3941	1,074.5



Flow Chart for 9” Parshall Flume

0.86	1.5725	2.4374	1,093.9
0.87	1.6006	2.4809	1,113.4
0.88	1.6288	2.5246	1,133.1
0.89	1.6572	2.5687	1,152.8
0.90	1.6858	2.6129	1,172.7
0.91	1.7145	2.6575	1,192.7
0.92	1.7434	2.7023	1,212.8
0.93	1.7725	2.7474	1,233.0
0.94	1.8017	2.7927	1,253.4
0.95	1.8311	2.8383	1,273.8
0.96	1.8607	2.8841	1,294.4
0.97	1.8905	2.9302	1,315.1
0.98	1.9204	2.9766	1,335.9
0.99	1.9504	3.0232	1,356.8
1.00	1.9806	3.0700	1,377.8
1.01	2.0110	3.1171	1,399.0
1.02	2.0416	3.1644	1,420.2
1.03	2.0723	3.2120	1,441.6
1.04	2.103	3.260	1,463.027
1.05	2.1342	3.3079	1,484.6
1.06	2.1653	3.3563	1,506.3
1.07	2.1967	3.4048	1,528.1
1.08	2.2282	3.4536	1,550.0
1.09	2.2598	3.5027	1,572.0
1.10	2.2916	3.5520	1,594.1
1.11	2.3235	3.6015	1,616.3
1.12	2.3556	3.6513	1,638.7
1.13	2.3879	3.7012	1,661.1
1.14	2.4203	3.7515	1,683.7
1.15	2.4529	3.8019	1,706.3
1.16	2.4856	3.8526	1,729.1
1.17	2.5184	3.9036	1,751.9
1.18	2.5514	3.9547	1,774.9
1.19	2.5846	4.0061	1,798.0
1.20	2.6179	4.0578	1,821.1
1.21	2.6514	4.1096	1,844.4
1.22	2.6850	4.1617	1,867.8
1.23	2.7187	4.2140	1,891.2
1.24	2.7526	4.2665	1,914.8
1.25	2.7866	4.3193	1,938.5

1.26	2.8208	4.3723	1,962.3
1.27	2.8551	4.4255	1,986.1
1.28	2.8896	4.4789	2,010.1
1.29	2.9242	4.5325	2,034.2
1.30	2.9590	4.5864	2,058.4
1.31	2.9939	4.6405	2,082.7
1.32	3.0289	4.6948	2,107.0
1.33	3.0641	4.7493	2,131.5
1.34	3.0994	4.8041	2,156.1
1.35	3.1349	4.8590	2,180.7
1.36	3.1705	4.9142	2,205.5
1.37	3.2062	4.9696	2,230.4
1.38	3.2421	5.0252	2,255.3
1.39	3.2781	5.0810	2,280.4
1.40	3.3142	5.1371	2,305.5
1.41	3.3505	5.1933	2,330.8
1.42	3.3869	5.2498	2,356.1
1.43	3.4235	5.3064	2,381.5
1.44	3.4602	5.3633	2,407.1
1.45	3.4970	5.4204	2,432.7
1.46	3.5340	5.4777	2,458.4
1.47	3.5711	5.5352	2,484.2
1.48	3.6083	5.5929	2,510.1
1.49	3.6457	5.6508	2,536.1
1.50	3.6832	5.7090	2,562.2
1.51	3.7208	5.7673	2,588.4
1.52	3.7586	5.8258	2,614.6
1.53	3.7965	5.8846	2,641.0
1.54	3.8345	5.9435	2,667.5
1.55	3.8727	6.0027	2,694.0
1.56	3.9110	6.0620	2,720.6
1.57	3.9494	6.1216	2,747.4
1.58	3.9880	6.1814	2,774.2
1.59	4.0267	6.2413	2,801.1
1.60	4.0655	6.3015	2,828.1
1.61	4.1044	6.3618	2,855.2
1.62	4.1435	6.4224	2,882.4
1.63	4.1827	6.4831	2,909.6
1.64	4.2220	6.5441	2,937.0
1.65	4.2614	6.6052	2,964.4



Flow Chart for 9” Parshall Flume

1.66	4.3010	6.6666	2,992.0
1.67	4.3407	6.7281	3,019.6
1.68	4.3806	6.7899	3,047.3
1.69	4.4205	6.8518	3,075.1
1.70	4.4606	6.9139	3,103.0
1.71	4.5008	6.9763	3,130.9
1.72	4.5411	7.0388	3,159.0
1.73	4.5816	7.1015	3,187.1
1.74	4.6222	7.1644	3,215.4
1.75	4.6629	7.2275	3,243.7
1.76	4.7037	7.2908	3,272.1
1.77	4.7447	7.3542	3,300.6
1.78	4.7857	7.4179	3,329.2
1.79	4.8269	7.4818	3,357.8
1.80	4.8683	7.5458	3,386.6
1.81	4.9097	7.6100	3,415.4
1.82	4.9513	7.6745	3,444.3
1.83	4.9929	7.7391	3,473.3
1.84	5.0348	7.8039	3,502.4
1.85	5.0767	7.8688	3,531.5

1.86	5.1187	7.9340	3,560.8
1.87	5.1609	7.9994	3,590.1
1.88	5.2032	8.0649	3,619.5
1.89	5.2456	8.1306	3,649.0
1.90	5.2881	8.1966	3,678.6
1.91	5.3307	8.2627	3,708.3
1.92	5.3735	8.3289	3,738.0
1.93	5.4164	8.3954	3,767.9
1.94	5.4594	8.4620	3,797.8
1.95	5.5025	8.5289	3,827.8
1.96	5.5457	8.5959	3,857.8
1.97	5.5891	8.6631	3,888.0
1.98	5.6325	8.7304	3,918.2
1.99	5.6761	8.7980	3,948.5
2.00	5.7198	8.8657	3,978.9



Flow Chart for 18" Parshall Flume

Head (feet)	MGD	CFS	GPM
0.16			
0.17			
0.18			
0.19			
0.20	0.326	0.505	226.56
0.21	0.351	0.544	244.22
0.22	0.377	0.585	262.33
0.23	0.404	0.626	280.89
0.24	0.431	0.668	299.89
0.25	0.459	0.712	319.33
0.26	0.488	0.756	339.18
0.27	0.517	0.801	359.45
0.28	0.546	0.847	380.13
0.29	0.577	0.894	401.21
0.30	0.608	0.942	422.68
0.31	0.639	0.991	444.55
0.32	0.671	1.040	466.79
0.33	0.704	1.091	489.42
0.34	0.737	1.142	512.41
0.35	0.770	1.194	535.77
0.36	0.804	1.247	559.50
0.37	0.839	1.300	583.58
0.38	0.874	1.355	608.01
0.39	0.910	1.410	632.79
0.40	0.946	1.466	657.92
0.41	0.982	1.523	683.39
0.42	1.019	1.580	709.19
0.43	1.057	1.638	735.32
0.44	1.095	1.697	761.79
0.45	1.134	1.757	788.58
0.46	1.173	1.817	815.69
0.47	1.212	1.879	843.12
0.48	1.252	1.940	870.87
0.49	1.292	2.003	898.93
0.50	1.333	2.066	927.30
0.51	1.374	2.130	955.98
0.52	1.416	2.195	984.96
0.53	1.458	2.260	1,014.2
0.54	1.501	2.326	1,043.8
0.55	1.543	2.392	1,073.7

Head (feet)	MGD	CFS	GPM
0.56	1.587	2.460	1,103.9
0.57	1.631	2.527	1,134.3
0.58	1.675	2.596	1,165.1
0.59	1.719	2.665	1,196.1
0.60	1.764	2.735	1,227.4
0.61	1.810	2.805	1,259.0
0.62	1.856	2.876	1,290.9
0.63	1.902	2.948	1,323.1
0.64	1.949	3.020	1,355.5
0.65	1.996	3.093	1,388.2
0.66	2.043	3.167	1,421.2
0.67	2.091	3.241	1,454.5
0.68	2.139	3.316	1,488.0
0.69	2.188	3.391	1,521.8
0.70	2.237	3.467	1,555.8
0.71	2.286	3.543	1,590.2
0.72	2.336	3.620	1,624.7
0.73	2.386	3.698	1,659.6
0.74	2.436	3.776	1,694.7
0.75	2.487	3.855	1,730.0
0.76	2.538	3.934	1,765.6
0.77	2.590	4.014	1,801.5
0.78	2.642	4.094	1,837.6
0.79	2.694	4.175	1,873.9
0.80	2.746	4.257	1,910.5
0.81	2.799	4.339	1,947.4
0.82	2.853	4.422	1,984.5
0.83	2.906	4.505	2,021.8
0.84	2.960	4.589	2,059.4
0.85	3.015	4.673	2,097.3
0.86	3.070	4.758	2,135.3
0.87	3.125	4.843	2,173.6
0.88	3.180	4.929	2,212.2
0.89	3.236	5.015	2,251.0
0.90	3.292	5.102	2,290.0
0.91	3.348	5.190	2,329.2
0.92	3.405	5.278	2,368.7
0.93	3.462	5.366	2,408.4
0.94	3.520	5.455	2,448.4
0.95	3.577	5.545	2,488.5



Flow Chart for 18" Parshall Flume

0.96	3.635	5.635	2,528.9
0.97	3.694	5.725	2,569.6
0.98	3.753	5.816	2,610.4
0.99	3.812	5.908	2,651.5
1.00	3.871	6.000	2,692.8
1.01	3.931	6.093	2,734.3
1.02	3.991	6.186	2,776.1
1.03	4.051	6.279	2,818.0
1.04	4.112	6.373	2,860.2
1.05	4.173	6.468	2,902.6
1.06	4.234	6.563	2,945.3
1.07	4.295	6.658	2,988.1
1.08	4.357	6.754	3,031.2
1.09	4.420	6.850	3,074.4
1.10	4.482	6.947	3,117.9
1.11	4.545	7.045	3,161.6
1.12	4.608	7.142	3,205.5
1.13	4.671	7.241	3,249.7
1.14	4.735	7.340	3,294.0
1.15	4.799	7.439	3,338.5
1.16	4.864	7.539	3,383.3
1.17	4.928	7.639	3,428.3
1.18	4.993	7.739	3,473.4
1.19	5.058	7.840	3,518.8
1.20	5.124	7.942	3,564.4
1.21	5.190	8.044	3,610.2
1.22	5.256	8.147	3,656.2
1.23	5.322	8.249	3,702.4
1.24	5.389	8.353	3,748.8
1.25	5.456	8.457	3,795.3
1.26	5.523	8.561	3,842.1
1.27	5.591	8.666	3,889.1
1.28	5.659	8.771	3,936.3
1.29	5.727	8.876	3,983.7
1.30	5.795	8.982	4,031.3
1.31	5.864	9.089	4,079.1
1.32	5.933	9.196	4,127.1
1.33	6.002	9.303	4,175.3
1.34	6.072	9.411	4,223.7
1.35	6.141	9.519	4,272.3

1.36	6.212	9.628	4,321.0
1.37	6.282	9.737	4,370.0
1.38	6.353	9.847	4,419.1
1.39	6.424	9.957	4,468.5
1.40	6.495	10.067	4,518.0
1.41	6.566	10.178	4,567.8
1.42	6.638	10.289	4,617.7
1.43	6.710	10.401	4,667.8
1.44	6.782	10.513	4,718.1
1.45	6.855	10.625	4,768.6
1.46	6.928	10.738	4,819.2
1.47	7.001	10.851	4,870.1
1.48	7.074	10.965	4,921.2
1.49	7.148	11.079	4,972.4
1.50	7.222	11.194	5,023.8
1.51	7.296	11.309	5,075.4
1.52	7.370	11.424	5,127.2
1.53	7.445	11.540	5,179.2
1.54	7.520	11.656	5,231.3
1.55	7.595	11.773	5,283.7
1.56	7.671	11.890	5,336.2
1.57	7.747	12.007	5,388.9
1.58	7.823	12.125	5,441.8
1.59	7.899	12.243	5,494.8
1.60	7.975	12.362	5,548.1
1.61	8.052	12.481	5,601.5
1.62	8.129	12.600	5,655.1
1.63	8.207	12.720	5,708.9
1.64	8.284	12.840	5,762.8
1.65	8.362	12.961	5,816.9
1.66	8.440	13.082	5,871.2
1.67	8.518	13.204	5,925.7
1.68	8.597	13.325	5,980.4
1.69	8.676	13.447	6,035.2
1.70	8.755	13.570	6,090.2
1.71	8.834	13.693	6,145.4
1.72	8.914	13.816	6,200.8
1.73	8.994	13.940	6,256.3
1.74	9.074	14.064	6,312.0
1.75	9.154	14.189	6,367.9



Flow Chart for 18" Parshall Flume

1.76	9.235	14.314	6,424.0
1.77	9.315	14.439	6,480.2
1.78	9.396	14.565	6,536.6
1.79	9.478	14.691	6,593.1
1.80	9.559	14.817	6,649.9
1.81	9.641	14.944	6,706.8
1.82	9.723	15.071	6,763.8
1.83	9.805	15.199	6,821.1
1.84	9.888	15.326	6,878.5
1.85	9.971	15.455	6,936.1
1.86	10.054	15.583	6,993.8
1.87	10.137	15.712	7,051.7
1.88	10.221	15.842	7,109.8
1.89	10.304	15.972	7,168.1
1.90	10.388	16.102	7,226.5
1.91	10.472	16.232	7,285.1
1.92	10.557	16.363	7,343.8
1.93	10.642	16.494	7,402.7
1.94	10.727	16.626	7,461.8
1.95	10.812	16.758	7,521.0
1.96	10.897	16.890	7,580.4
1.97	10.983	17.023	7,640.0
1.98	11.069	17.156	7,699.7
1.99	11.155	17.290	7,759.6
2.00	11.241	17.423	7,819.7
2.01	11.328	17.558	7,879.9
2.02	11.414	17.692	7,940.3
2.03	11.501	17.827	8,000.8
2.04	11.589	17.962	8,061.5
2.05	11.676	18.098	8,122.3
2.06	11.764	18.234	8,183.4
2.07	11.852	18.370	8,244.5
2.08	11.940	18.507	8,305.9
2.09	12.028	18.644	8,367.4
2.10	12.117	18.781	8,429.0
2.11	12.206	18.919	8,490.8
2.12	12.295	19.057	8,552.8
2.13	12.384	19.195	8,614.9
2.14	12.474	19.334	8,677.2
2.15	12.563	19.473	8,739.7

2.16	12.653	19.613	8,802.3
2.17	12.744	19.753	8,865.0
2.18	12.834	19.893	8,927.9
2.19	12.925	20.033	8,991.0
2.20	13.016	20.174	9,054.2
2.21	13.107	20.315	9,117.6
2.22	13.198	20.457	9,181.1
2.23	13.290	20.599	9,244.8
2.24	13.381	20.741	9,308.6
2.25	13.473	20.884	9,372.6
2.26	13.566	21.027	9,436.8
2.27	13.658	21.170	9,501.1
2.28	13.751	21.314	9,565.5
2.29	13.844	21.457	9,630.1
2.30	13.937	21.602	9,694.9
2.31	14.030	21.746	9,759.8
2.32	14.123	21.891	9,824.8
2.33	14.217	22.037	9,890.0
2.34	14.311	22.182	9,955.4
2.35	14.405	22.328	10,021
2.36	14.500	22.474	10,087
2.37	14.594	22.621	10,152
2.38	14.689	22.768	10,218
2.39	14.784	22.915	10,284
2.40	14.879	23.063	10,351
2.41	14.975	23.211	10,417
2.42	15.070	23.359	10,484
2.43	15.166	23.508	10,550
2.44	15.262	23.657	10,617
2.45	15.359	23.806	10,684
2.46	15.455	23.956	10,751
2.47	15.552	24.106	10,819
2.48	15.649	24.256	10,886
2.49	15.746	24.407	10,954
2.50	15.844	24.557	11,021

REVISIONS				
REV.	DESCRIPTION	NCR/ECO NO.	REVISED BY	DATE
A	FOR APPROVAL		C. BARTCH	2/27/2012

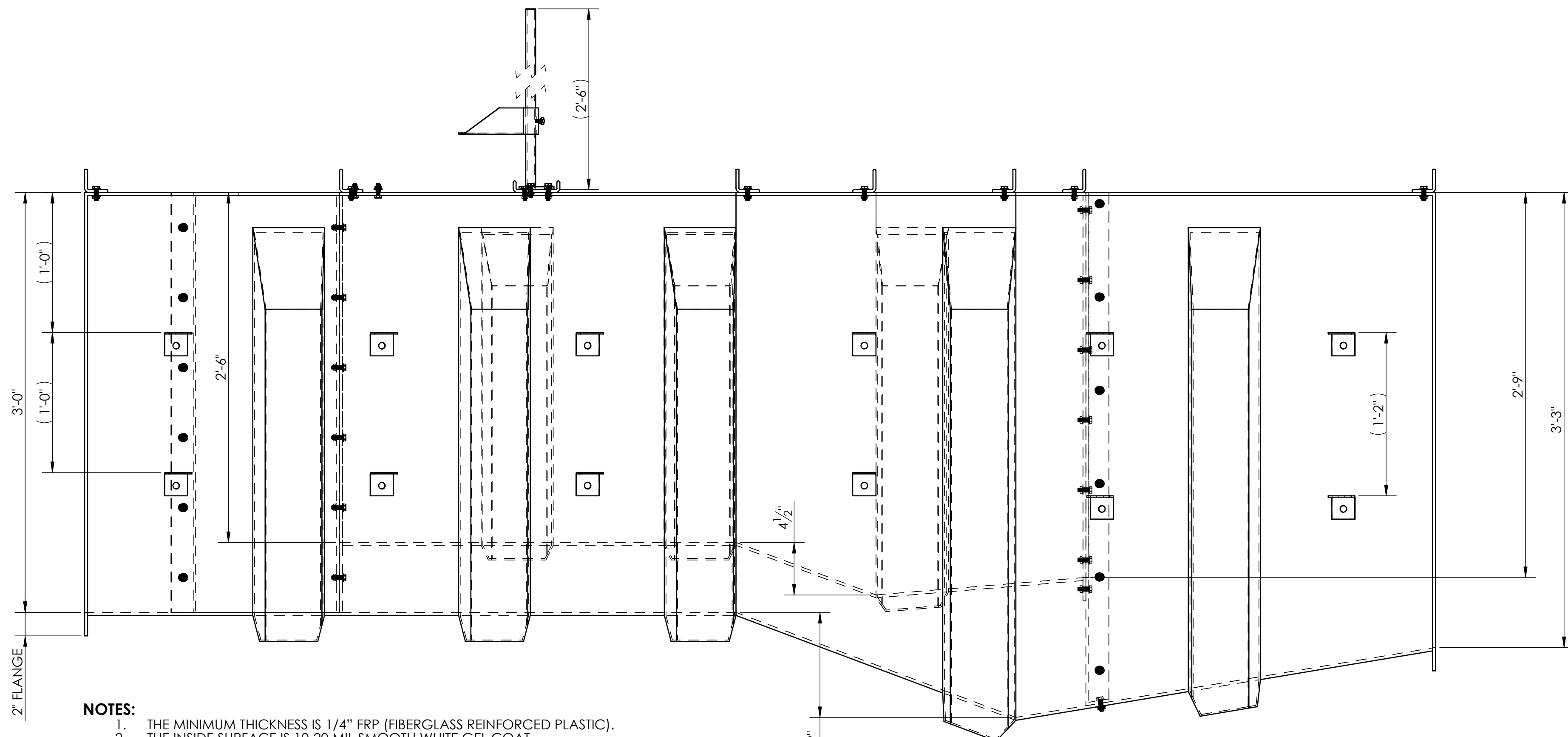
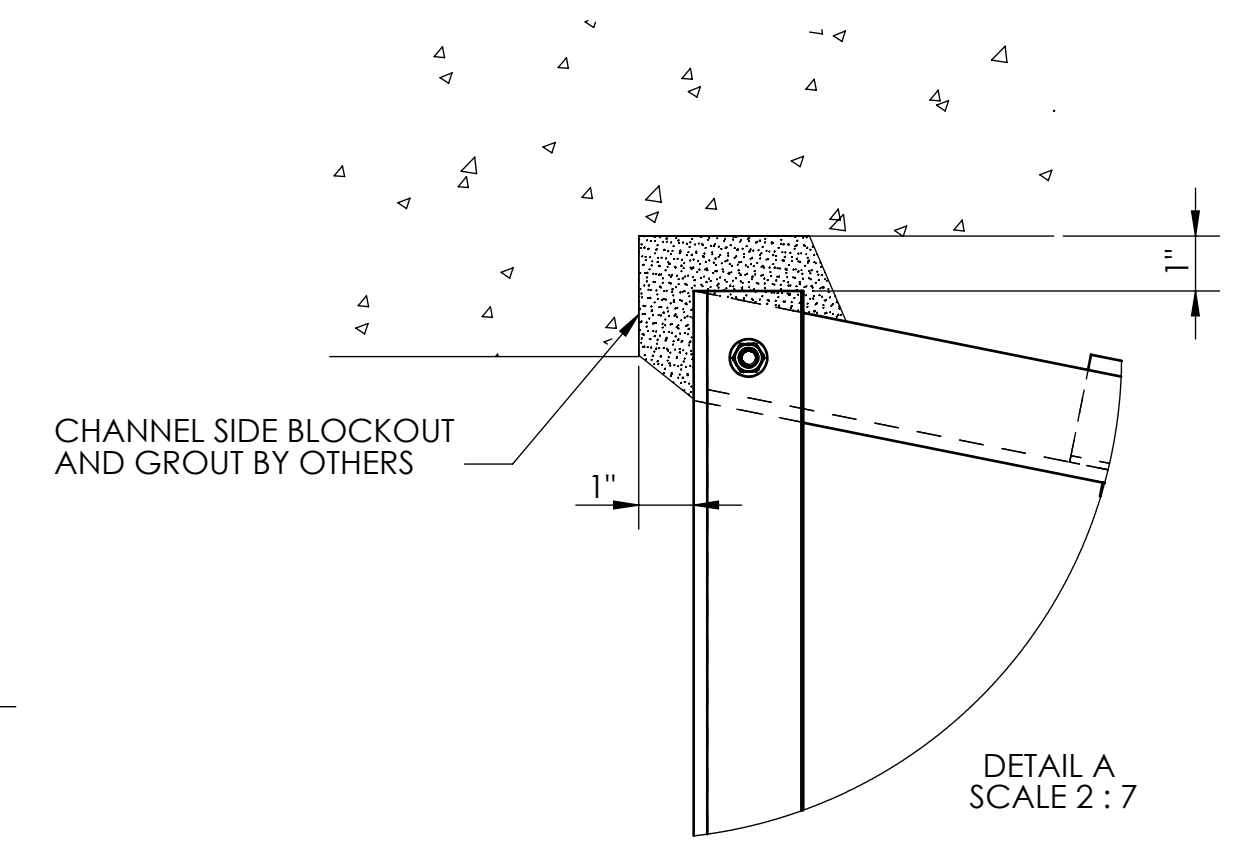
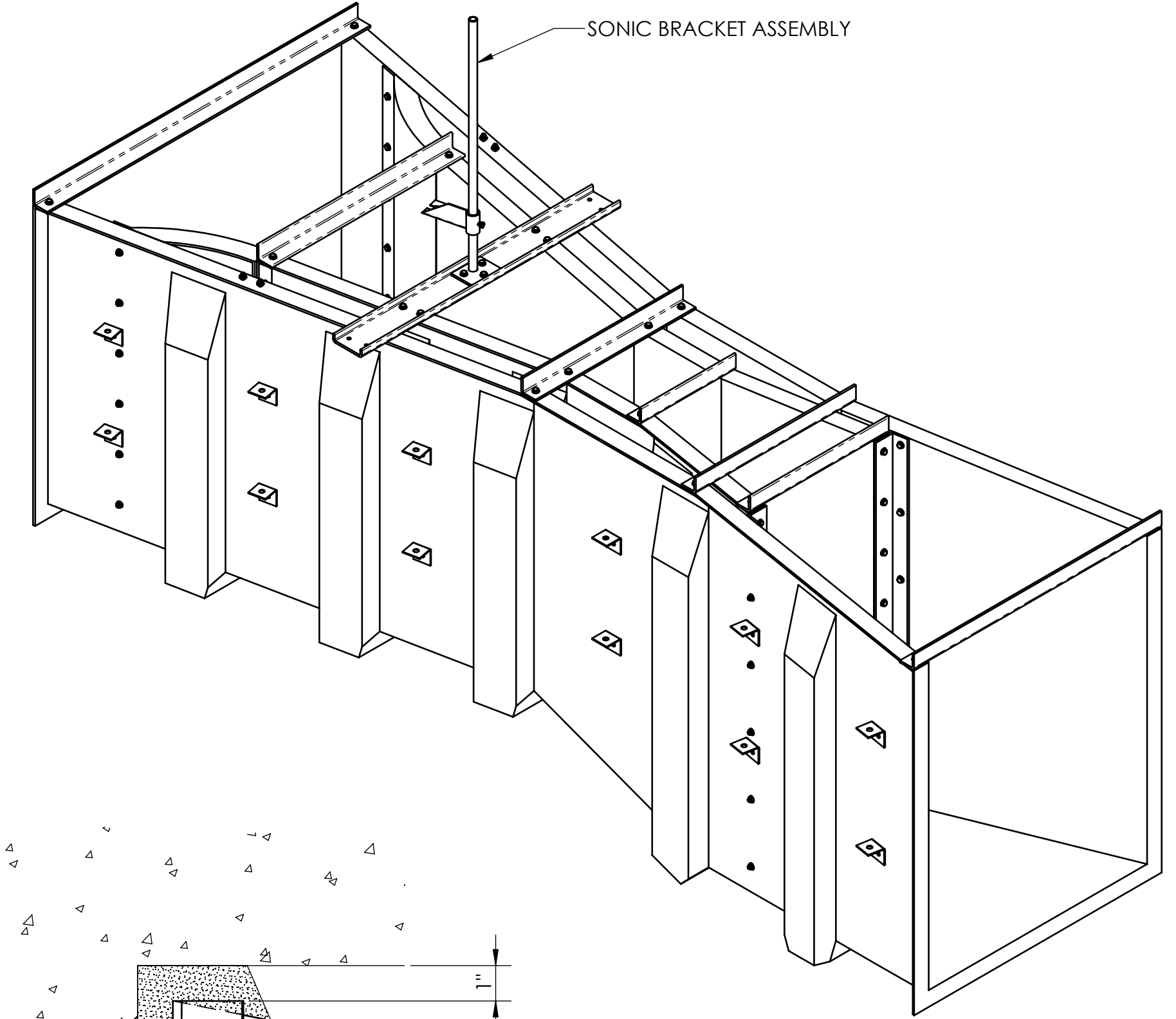
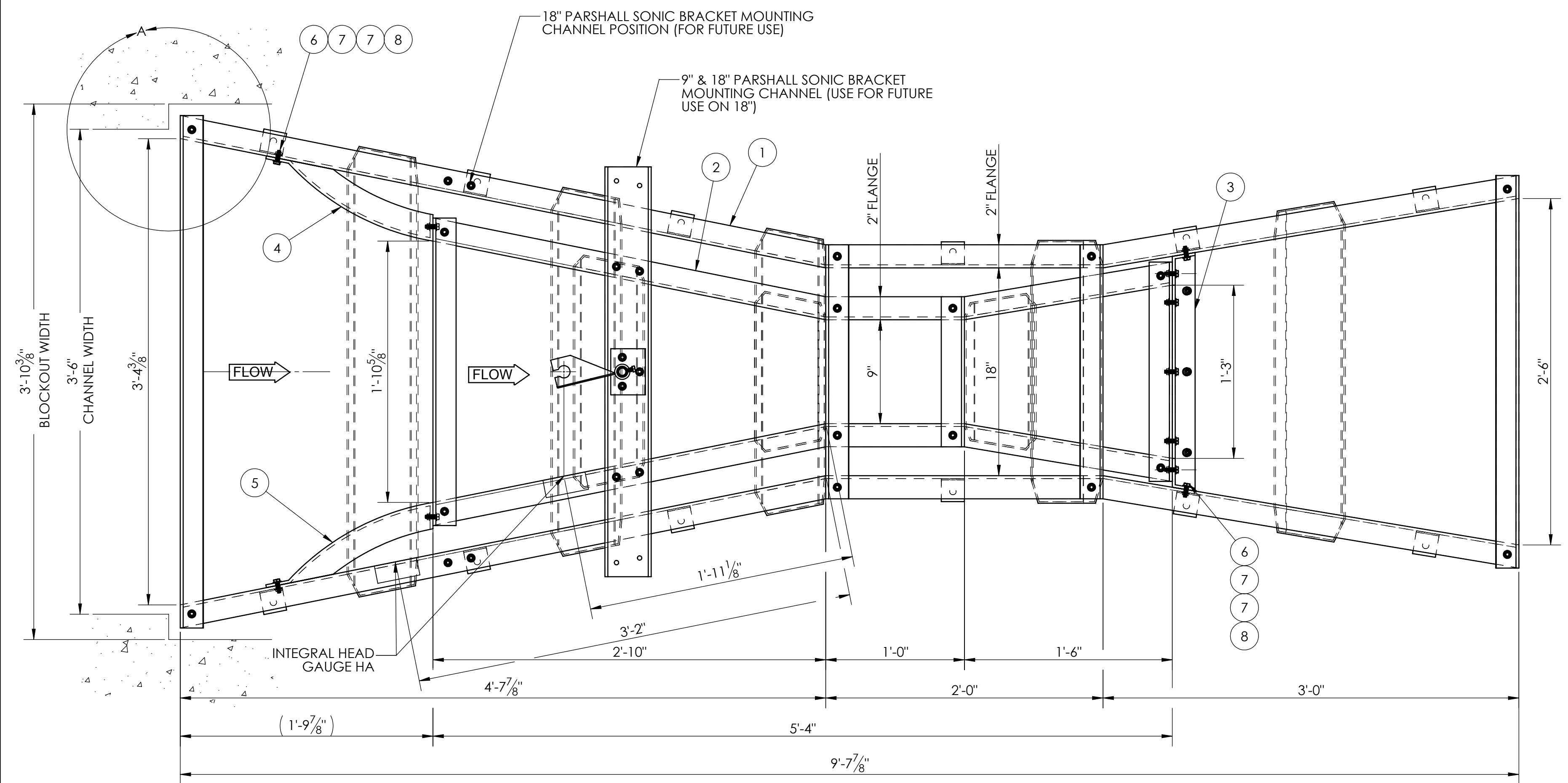

- NOTES:**
1. THE MINIMUM THICKNESS IS 1/4" FRP (FIBERGLASS REINFORCED PLASTIC).
 2. THE INSIDE SURFACE IS 10-20 MIL SMOOTH WHITE GEL COAT.
 3. THE OUTSIDE SURFACE IS WHITE GEL COAT.
 4. MINIMUM GLASS CONTENT IS 30%, EXCLUSIVE OF RESIN RICH SURFACES.
 5. THE HEAD GAGE (100THS OF A FOOT) IS MOLDED INTO THE SIDE OF THE FLUME.
 6. PLACE LARGE FLOW DIRECTION ARROW DECAL ON BOTTOM OF FLUME @ APPROXIMATELY 3' FROM INLET END.
 7. PLACE PLASTI-FAB LOGO LABEL ON TOP FLANGE AT APPROXIMATE CENTER-LINE OF MEASUREMENT POINT OR GAGE LOCATION.
 8. WEIGHT SHOWN ON DRAWING IS TOTAL WEIGHT FOR BOTH FLUMES.
 9. RESIN: CCP STYPOL C1-1200-22.

BOM TABLE			
ITEM NO.	QTY.	DESCRIPTION	MATERIAL
1	1	18" PARSHALL FLUME	FRP (HLU, POLYESTER)
2	1	9" PARSHALL FLUME SET-UP TO NEST INTO 18" PARSHALL FLUME	FRP (HLU, POLYESTER)
3	1	OUTLET BULKHEAD, 9" PARSHALL FLUME NESTED IN 18" PARSHALL FLUME	FRP (HLU, POLYESTER)
4	1	INLET WING WALL, RIGHT SIDE, 18" PARSHALL FLUME X 3'-0" LG	FRP (HLU, POLYESTER)
5	1	INLET WING WALL, LEFT SIDE, 18" PARSHALL FLUME X 3'-0" LG	FRP (HLU, POLYESTER)
6	56	HEX HEAD CAP SCREW, 5/16-18UNC X 1" LG., T-316-S/S	T-316 S/S
7	112	FLAT WASHER, 5/16	T-316 S/S
8	56	HEX NUT, 5/16-18UNC	T-316 S/S

PROJECT: HAROLD D THOMPSON WATER RECLAMATION FOUNTAIN, COLORADO USA CUSTOMER: WEAVER CONSTRUCTION REP: GOBLE SAMPSON P.O. NO.: LOI	 TUALATIN, OR. UNLESS OTHERWISE SPECIFIED, DIMENSIONS ARE IN FEET/INCHES TOLERANCES UNLESS OTHERWISE SPECIFIED: ≤ 6'-0" ± 1/16" > 6'-0" AND ≤ 25'-0" ± 1/8" > 25'-0" ± 1/2"	PLASTI-FAB PART NUMBER: MATERIAL INFORMATION: SPECIAL FINISH REQUIREMENT:	TITLE: 9" PARSHALL FLUME NESTED IN 18" PARSHALL FLUME QUANTITY (1) ONLY
PROPRIETARY AND CONFIDENTIAL THE INFORMATION CONTAINED IN THIS DRAWING IS THE SOLE PROPERTY OF PLASTI-FAB. ANY REPRODUCTION IN PART OR AS A WHOLE WITHOUT THE WRITTEN PERMISSION OF PLASTI-FAB IS PROHIBITED.	NAME: C. BARTCH DATE: 2/27/2012 CHECKED BY:	SIZE: D DRAWING NO.: 121061-1A-01 WEIGHT: 355 SCALE: 1:8 SHEET: 1 OF 1	REV.: A



TYPICAL SPECIFICATIONS NESTED PARSHALL FLUMES

The flumes shall be a 9 inch Parshall nested in a 18 inch Parshall for measuring flows to 5.73 and 15.81 MGD respectively.

The flumes shall be full length, molded fiberglass reinforced polyester laminated in one piece. The interior surface shall have a 10 to 15 mil white gelcoat backed by a resin rich layer of resin and chopped glass to form a water and chemical resistant surface. The remainder of the laminate shall be fiberglass reinforced polyester containing not less than 30% glass content by weight. The thickness of the walls and floor of the flume shall be not less than 1/4". The outer chopped strand shall be Type E glass with silane finish and a styrene-soluble binder. The outer flume shall be reinforced with box section stiffeners down the sides and across the bottom. The stiffeners shall be joined together at the knee to form a rigid dimensionally stable flume. The flume shall be capable of being free standing, holding all dimensions without distortion, with a full head of water flowing through it. There shall be locking clips fastened along the side of the flume to be used for anchorage into the concrete.

The nested flume

1. will be constructed such that its approach and throat floor of the smaller flume will sit flat on top of the larger flume's approach and throat sections.
2. shall have flared entrance wing walls as needed and an outlet bulkhead to mate to the larger flume.
3. seating surfaces and joints to be sealed. Attachment to be done with T-304/T-316 stainless steel fasteners of adequate number to secure flume in place.
4. the smaller flume shall be strong enough to be free-standing and not require additional exterior supports to hold it dimensionally true.
5. flumes with a side stilling well will be provided with a side flow transition box mounted at the base of the smaller flume. The box will be designed to seat against the vertical wall and floor of the larger flume. It is to provide access from the smaller flume measurement point at H_a to the larger flume measurement point at H_a without additional holes. For nested flumes that where the space between the flumes is large enough; alternative flow transition methods may be used as long as they are easily accessible or a separate stilling well having at least an 8" diameter may be used.

Stiffeners across the top shall be permanent FRP pultruded cross supports for the smaller

flume and may be either the fiberglass or temporary wood spreaders for the larger flume as required for the job, and shall provide sufficient strength and structural support to resist the stresses that occur during shipping and proper installation of the flume. The flume shall be brace and supported during installation per manufactures suggestions. The flume shall be provided with: (Please select from the follow options. **Indicate right or left side of flume as viewed from the approach looking down stream.)

An adjustable T-304 stainless steel support bracket to mount an ultrasonic transducer over the waterway.

The Parshall flume shall be equipped with a molded in head gage graduated in 100ths of a foot and centimeters.

Typical physical properties shall be

ASTM D 638	Tensile strength	14,000 psi
ASTM D 790	Flexural strength	23,000 psi
ASTM D 790	Flexural modulus	0.80 x 10 ⁶ psi
ASTM D 256	Notched Izod Impact	10 ft. lbs./in.
ASTM D 2583	Barcol hardness	30
ASTM D 570	Water Absorption	<0.2% (in 24 hrs.)

Flume dimensions shall be within plus or minus 1/16th inch for flumes 12" and smaller. For 18" to 24" flumes the tolerance shall be plus or minus 3/32nd inch in the throat and plus or minus 1/8 inch elsewhere. Flumes 30" through 48" shall be plus or minus 1/8" in the throat and plus or minus 1/4" elsewhere.

INSTALLATION COMMENTS FOR NESTED FLUMES

1. The flume(s) should be installed level end-to-end and side-to-side.
2. Place the flume to be nested so that flat approach and throat sections rest directly on approach and throat of larger unit.
3. The leading edge of the throat section on both flumes should be aligned. (See print).
4. If the order calls for both flumes (not just one retrofit flume), the factory will run a bead of silicon sealant has been placed between the flanges, bulkhead and other contacting surfaces of the insert flume to provide a water tight seal. Retrofit flumes should also be sealed in the same manner.
5. If desired, the space between the sidewalls of the two flumes may be filled with sand or pea gravel and covered with a layer of breakable grout sloped toward the flume to help limit water collecting between flumes. Water will likely seep between the two flumes.

This will in no way affect the accuracy of the flume or compromise the flume in any manner.

6. At times it may be a good idea to remove the smaller flume during the installation to facilitate supporting the larger flume. Follow standard installation instructions that will come with the flume describing how to support and secure the flume in place. If both flumes installed together; the contractor will need to take extra time to pour smaller lifts (3"-4") along the walls to prevent the walls from bowing in during the installation. Some contractors have sealed off the ends of the flume and filled them with water to help provide inside support. Then lifts could be 4"-6". If the smaller flume is removed, the lifts could be up to 10" deep per layer.
7. Please note that these flumes are designed to be freestanding, and require no additional external support in order to maintain their dimensional integrity during operation.

The flume shall be as manufactured by Plasti-Fab, Inc. of Tualatin, Oregon.

Please consult your local representative or contact
Plasti-Fab, Inc., PO Box 100, Tualatin, Oregon, 97062.

PHONE 503-692-5460 FAX 503-692-1145

EMAIL SALES@PLASTI-FAB.COM WEB WWW.PLASTI-FAB.COM



LIMITED WARRANTY

Every effort is made to assure that our customers receive the highest quality merchandise, free of any defects in materials and workmanship. This merchandise has been designed for use in accordance with the project specifications, and the standards and/or instructions recommended by this catalog, or other written quotation of this firm. However, no warranty, expressed or implied, is made other than as follows:

When installed and operated correctly, Plasti-Fab guarantees this merchandise for 25 full years against functional failure due to corrosion of composite materials, and 24 full months against failure due to any defects in material and workmanship. Such warranty can only be enforced by the product end user. During the warranty period any defects in material or workmanship will be repaired or replaced at Plasti-Fab, Inc.'s option at no cost to the end user. Warranty specifically excludes damage due to improper handling, storage, misuse or neglect.

Measure of damage is the price of defective material only. No charges for labor or expense required to remove or replace defective material, or for any consequential damages, will be allowed. Any implied warranty of merchantability or fitness is limited to the 24 months duration of this written warranty. To the extent allowed by law, neither Plasti-Fab, Inc. nor its selling dealer or agent shall have any responsibility for loss of use of the product, loss of time, commercial loss or consequential damages.

A "pass-through" warranty is offered for products that are manufactured by other companies and furnished as a component part of a Plasti-Fab product. Typical examples of such products include, but are not limited to: air conditioning units, electric actuators and gearboxes, thermostats, solenoids, gages, controllers, heaters, blowers, and fans. Warranties on these products are pass-through, meaning the equipment warranty will be limited to that offered by the equipment's original manufacturer.

This warranty gives specific legal rights. Other rights vary from state to state and by country. In the event a warranted product is believed defective, please notify Plasti-Fab, Inc. Refer to Plasti-Fab job number, print number, installation location, address and telephone numbers listed in the O&M manual when requesting assistance. Provide date purchased and copy of invoice or shipping documents if possible.

It is the policy of this company to encourage the settlement of disputes in an informal manner, and if such disputes arise over a warranty claim, an informal dispute settlement mechanism can be agreed upon at that time.

Please consult your local representative or contact Plasti-Fab, Inc., PO Box 100, Tualatin Oregon 97062
PHONE 503.692.5460 **FAX** 503.692.1145 **E-MAIL** SALES@PLASTI-FAB.COM **WEB** WWW.PLASTI-FAB.COM