

Safe Listening Standards

Current and future prospects

Thomas Lund, Denmark

Convenor TC108X/WG3
Senior Technologist, Genelec OY, Finland

ITU Meeting • Genève • June 6, 2016

Standards

IEC – International Technical Commission - has members representing 83 countries worldwide

IEC/EN 60065 2011

Audio, video and similar electronic apparatus -
Safety requirements

IEC/EN 60950-1 2011

Information technology equipment - Safety -
Part 1: General requirements

IEC/EN 62368-1 2014

Audio/video, information and communication
equipment - Part 1: Safety requirements

EN 50332-1, -2 2013

Maximum sound pressure level measurement
methodology

EN 50332-3 2017?

Dose measurement methodology (ongoing)



Scientific Committee on Emerging and Newly Identified Health Risks

SCENIHR

Potential health risks of exposure to noise from personal music players and mobile phones including a music playing function

23rd of September, 2008



Required user protection

EN 50332-1: PMP and Headphones *together*

PMPs must be equipped with user protection if they are capable of delivering an SPL of 85 dB(A) when playing a *static test signal*:

- an active **warning** when SPL (of the test signal) is above 85 dB(A)
- a **maximum SPL** no higher than 100 dB(A)

EN 50332-2: PMP and Headphones *separate*

PMPs must be equipped with user protection if they are capable of delivering 27 mV RMS when playing a *static test signal*:

- an active **warning** when voltage (of the test signal) is above 27 mV
- a **maximum voltage** no higher than 150 mV

Maximum headphone sensitivity specified too

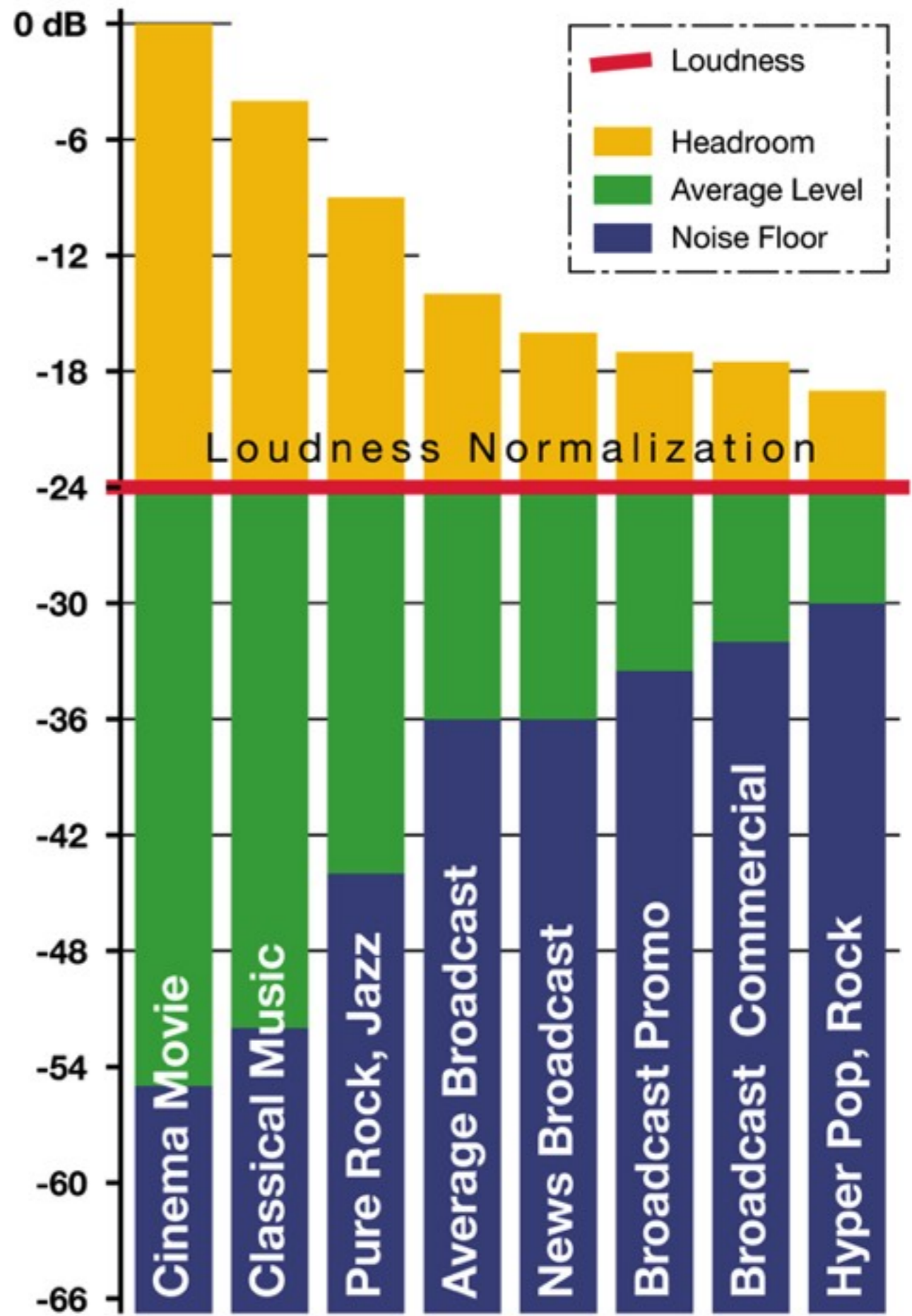
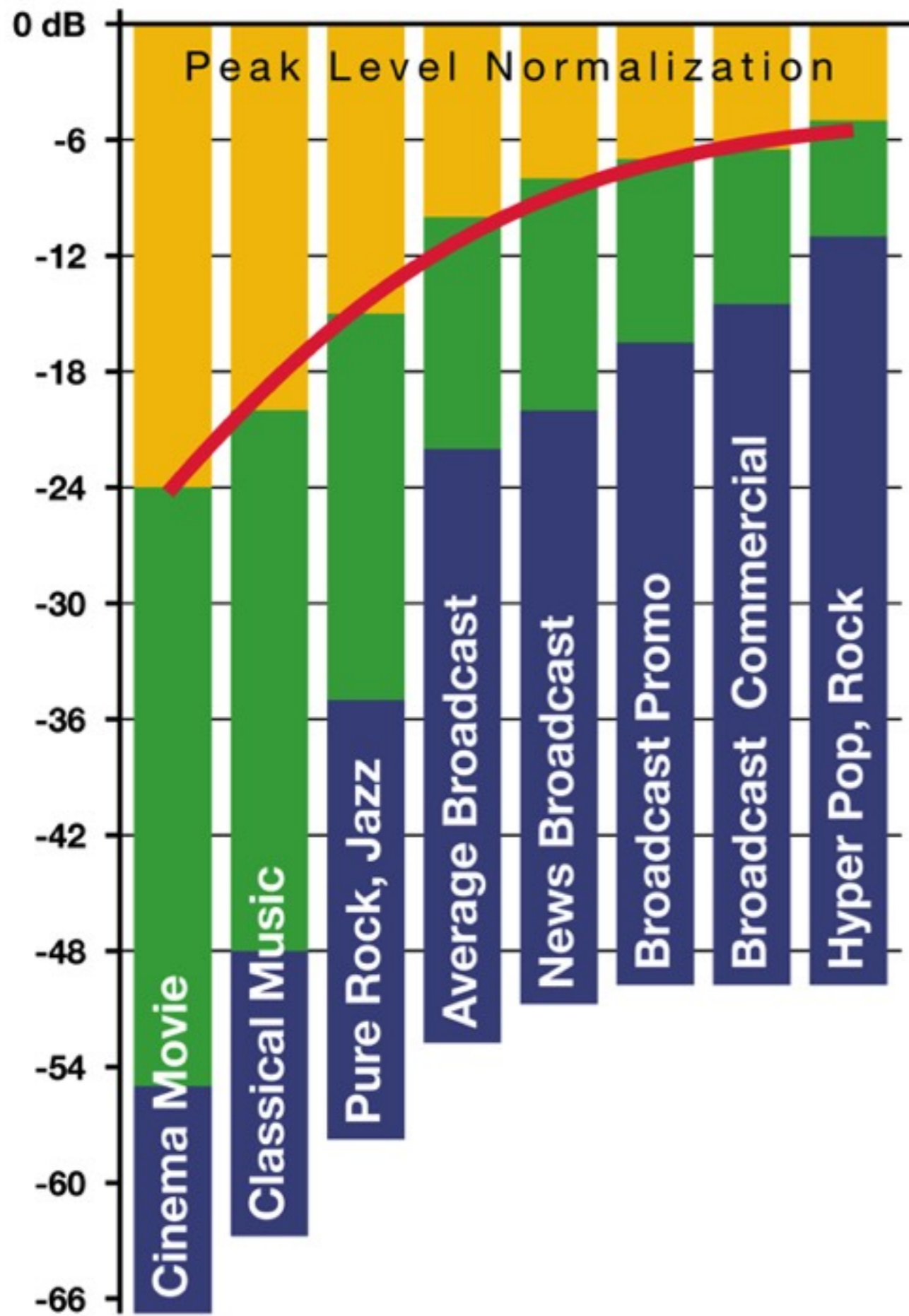

Program Loudness [LUFS]

True-Peak Level [dBTP]

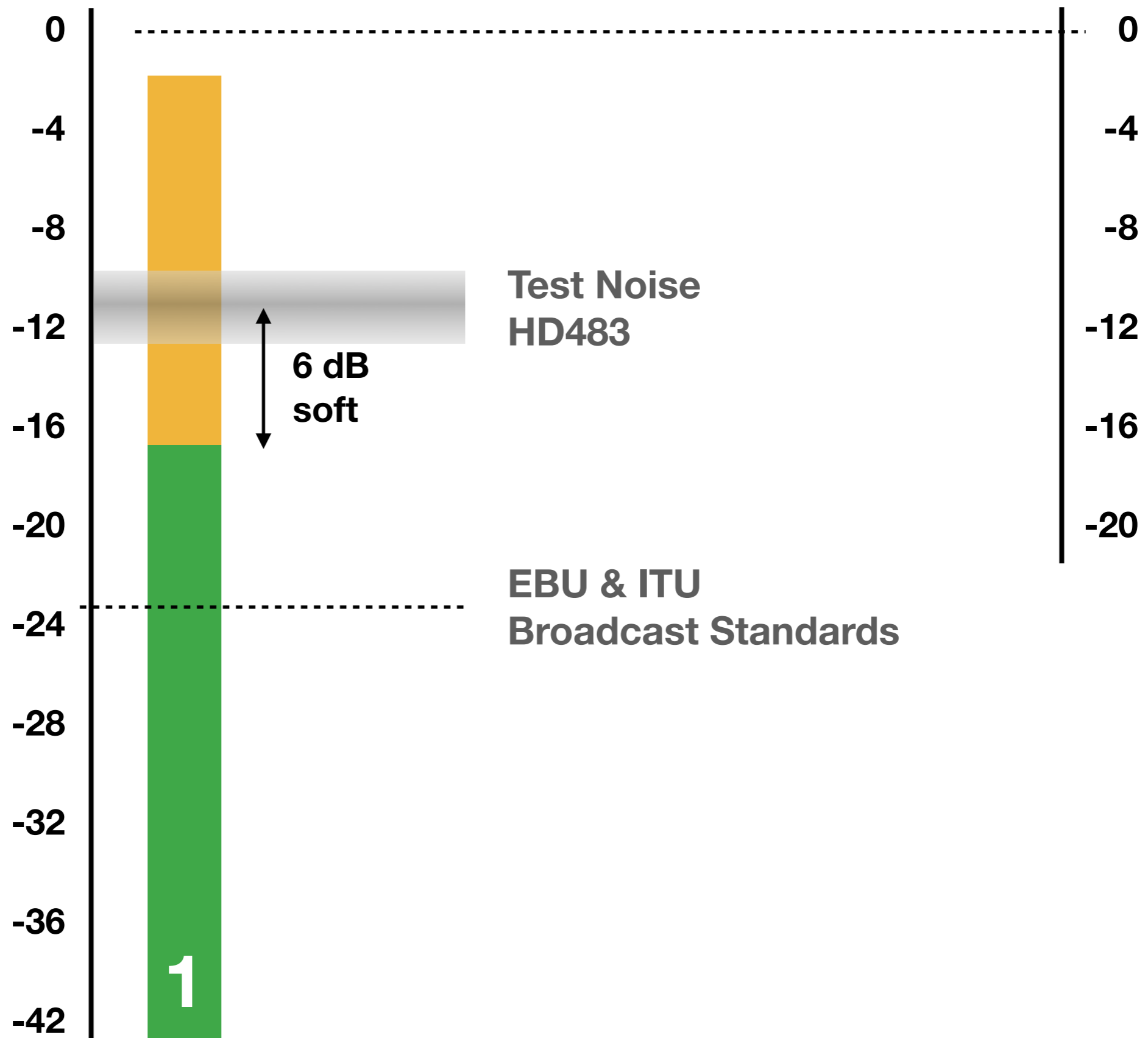

Program Loudness [LUFS]

True-Peak Level [dBTP]

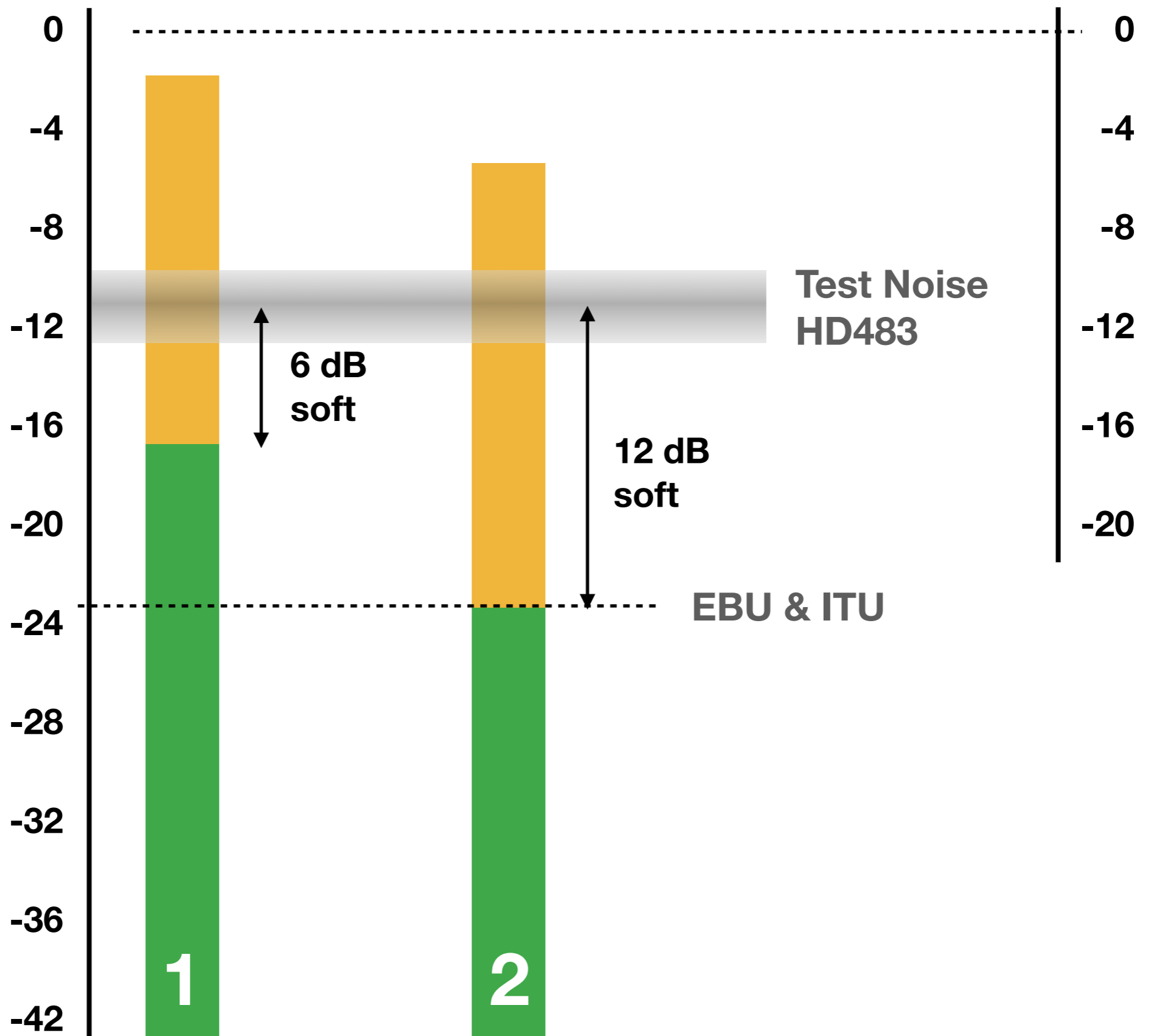

Program Loudness [LUFS]

True-Peak Level [dBTP]

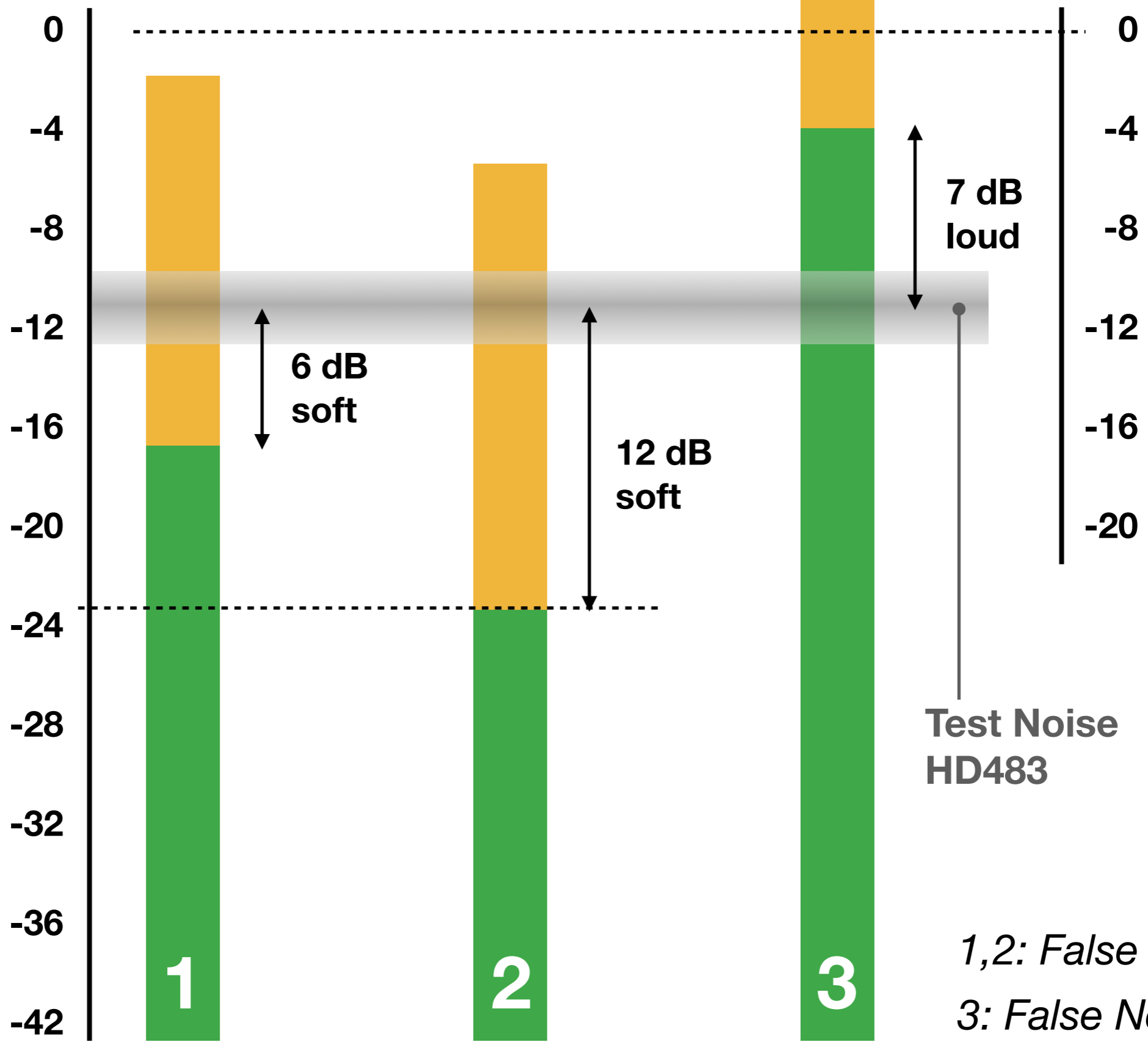

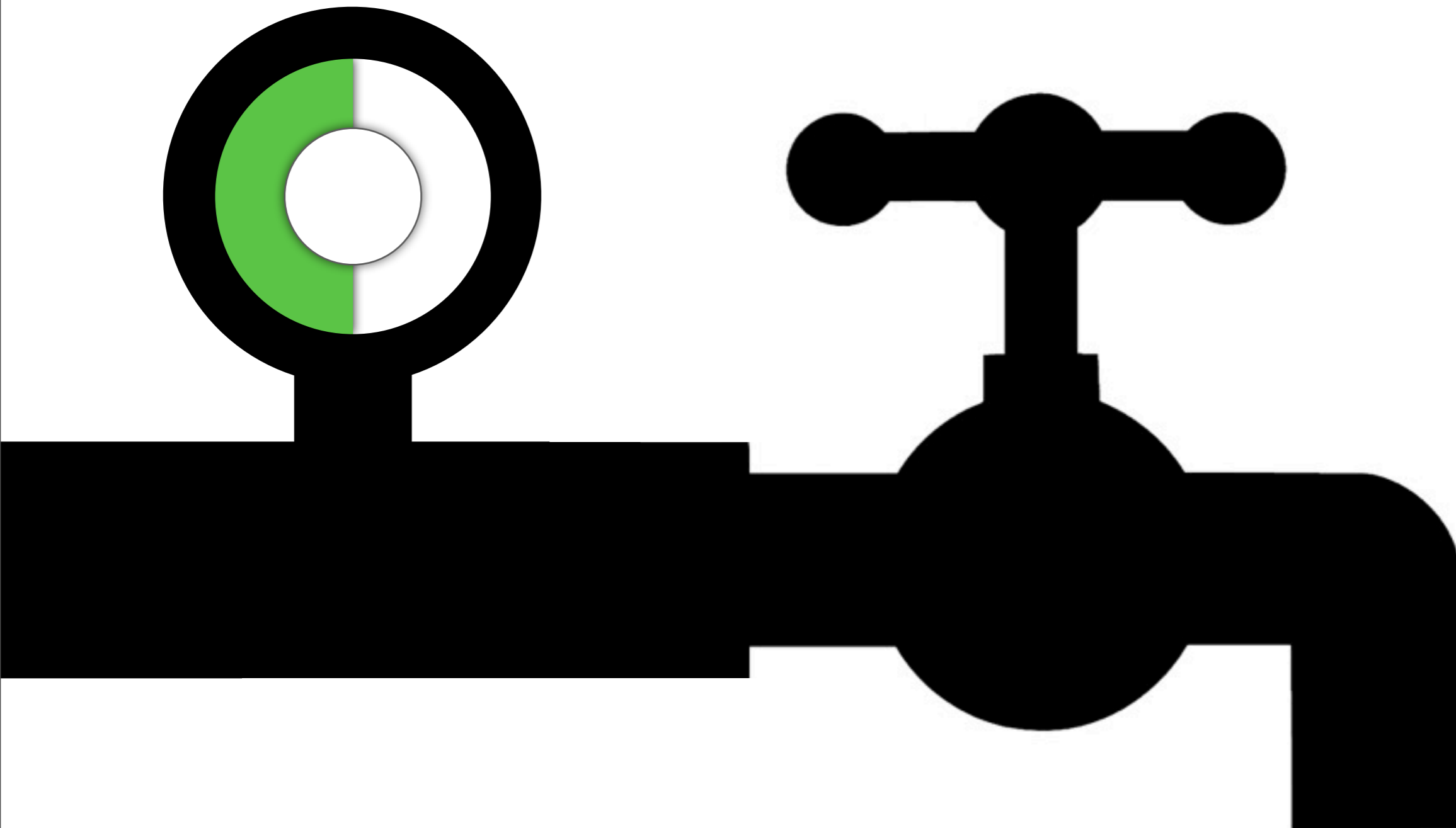

EN 50332-1, EN 50332-2

Doesn't work with ITU-R BS.1770

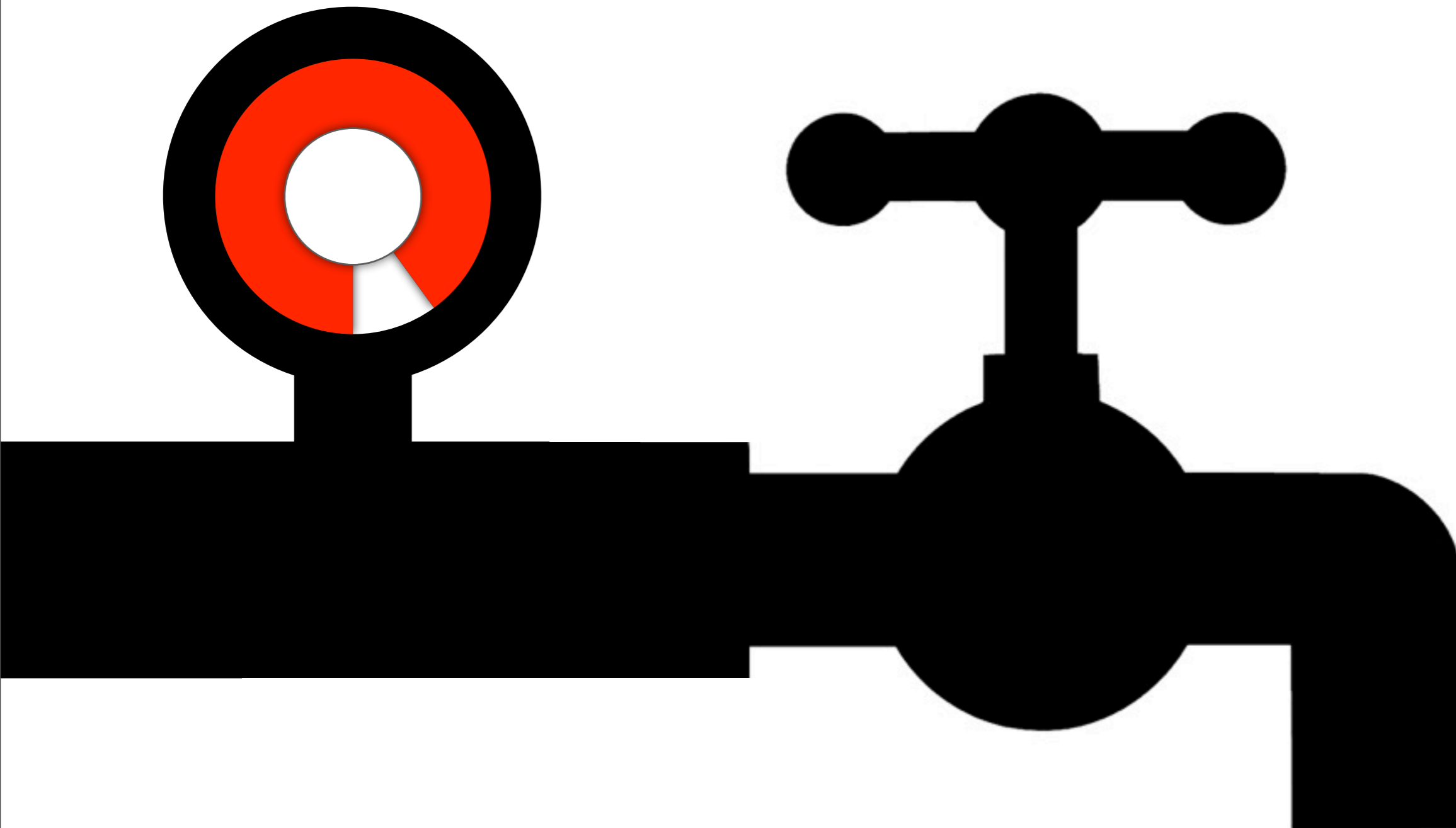

EN 50332-1, EN 50332-2

High “pressure” needed to get enough output

From Bob Ludwig



Mastering for McCartney, Springsteen, Bowie, Queen, Dire Straits, Stones, Madonna, Sinatra, Police, Eagles, Roxy Music, Coldplay, U2, AC/DC, Clapton etc. etc.

Greetings esteemed members of the WHO

The **art of music** is one of the highest expressions of intelligence devised by human beings.

New ITU and EBU standards finally free us from having to needlessly squash the literal life-giving qualities out of the music and programs.

The prevention of HL should **please not cancel these long-awaited improvements** and jeopardize music heritage further.

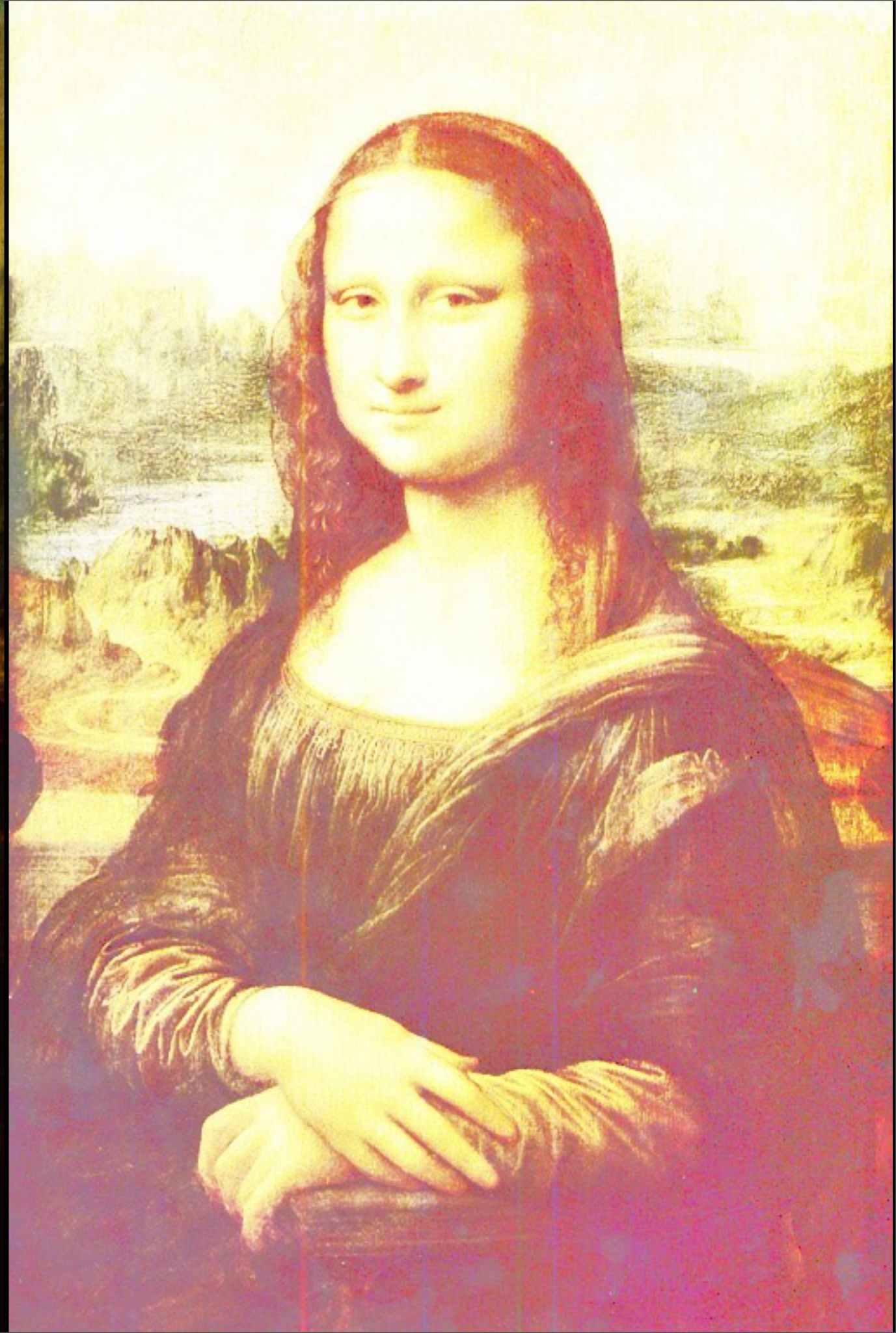

EN50332-1, EN50332-2

Upsides

Brought down maximum SPL in European PMPs

Raised awareness of a potentially big HL problem

Downsides

Prone to false negative warnings

Prone to false positive (irrelevant) warnings

Bad for music heritage

Bad for new ITU and EBU broadcast standards

 Dose estimation needed: EN50332-3

PMPs and HL

2.5 - 10 million people in Europe to develop HL because of PMPs

Requirements for PMPs sold in Europe: EN50332-1, EN50332-2

dB(A) SPL

Gourévitch et al., 2014

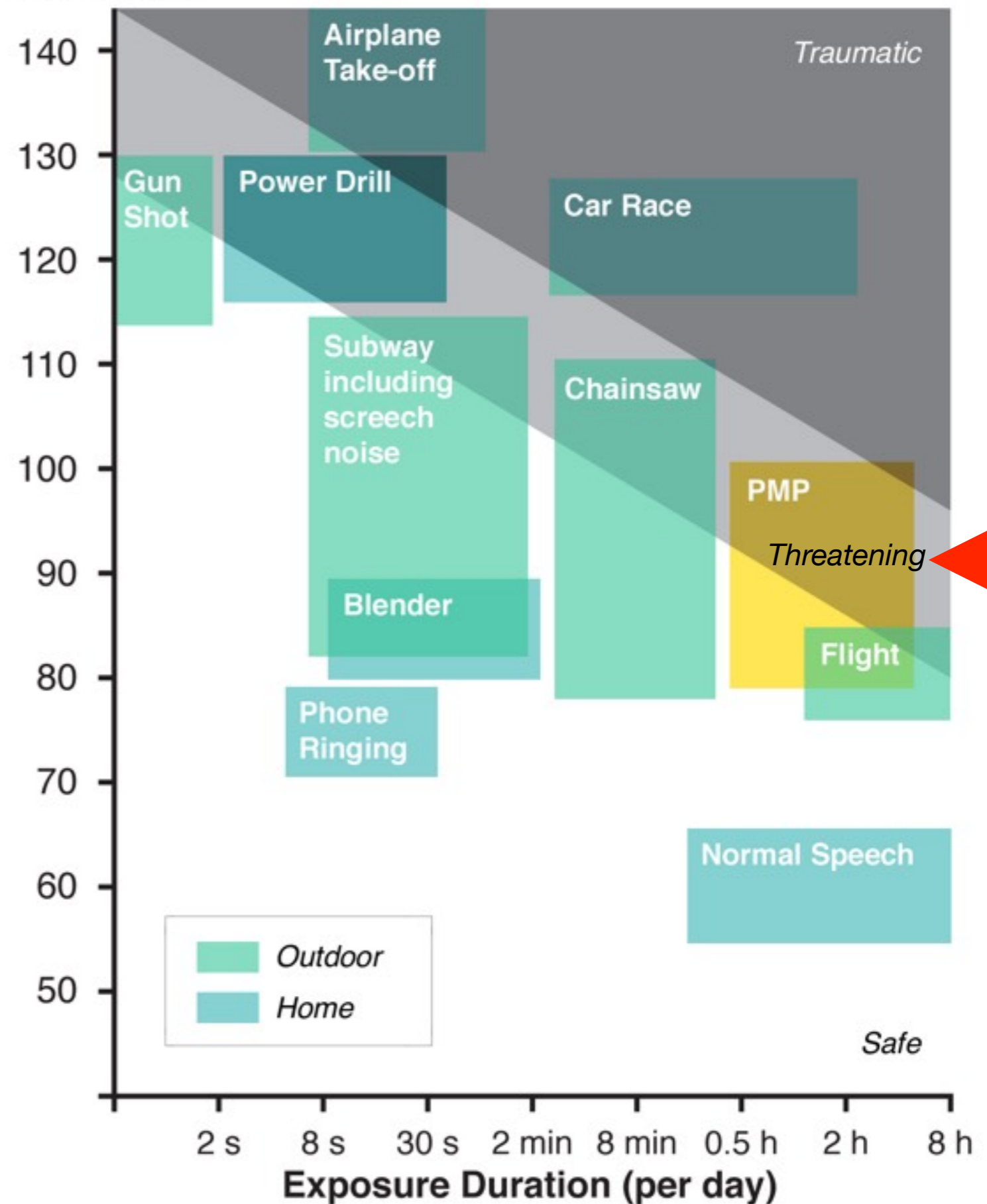

Gourévitch et al., 2014

Threatening noise levels

may cause damage that does not effect hearing thresholds, but gradually degrades auditory nerve fibers.



“Compressed music

delivered by most portable music players is closer to noise than the original music because the overall intensity of the whole spectrum is higher.

This global increase and the disappearance of quiet transients could harm the auditory system on a long-term basis...”

Sound Exposure Level considered just safe (EU)

SEL [dBA]	Time/Day	Time/Week
107	1 min	4.5 min
104	2 min	9.5 min
101	4 min	19 min
98	7.5 min	37.5 min
95	15 min	75 min
92	30 min	2.5 hours
89	1 hour	5 hours
86	2 hours	10 hours
83	4 hours	20 hours
80	8 hours	40 hours

Exposure and Dose

Sound Exposure

A-weighted sound pressure, p , squared and integrated over a stated period of time, T .

$$E = \frac{1}{T} \int_0^T p(t)^2 dt$$

Sound Exposure Level

Logarithmic measure of sound exposure relative to the threshold of hearing in humans.

$$SEL = 10 \log_{10} \left(\frac{E}{E_0} \right)$$

Dose %

Sound exposure interpreted as a percentage, where 100% is considered just safe.

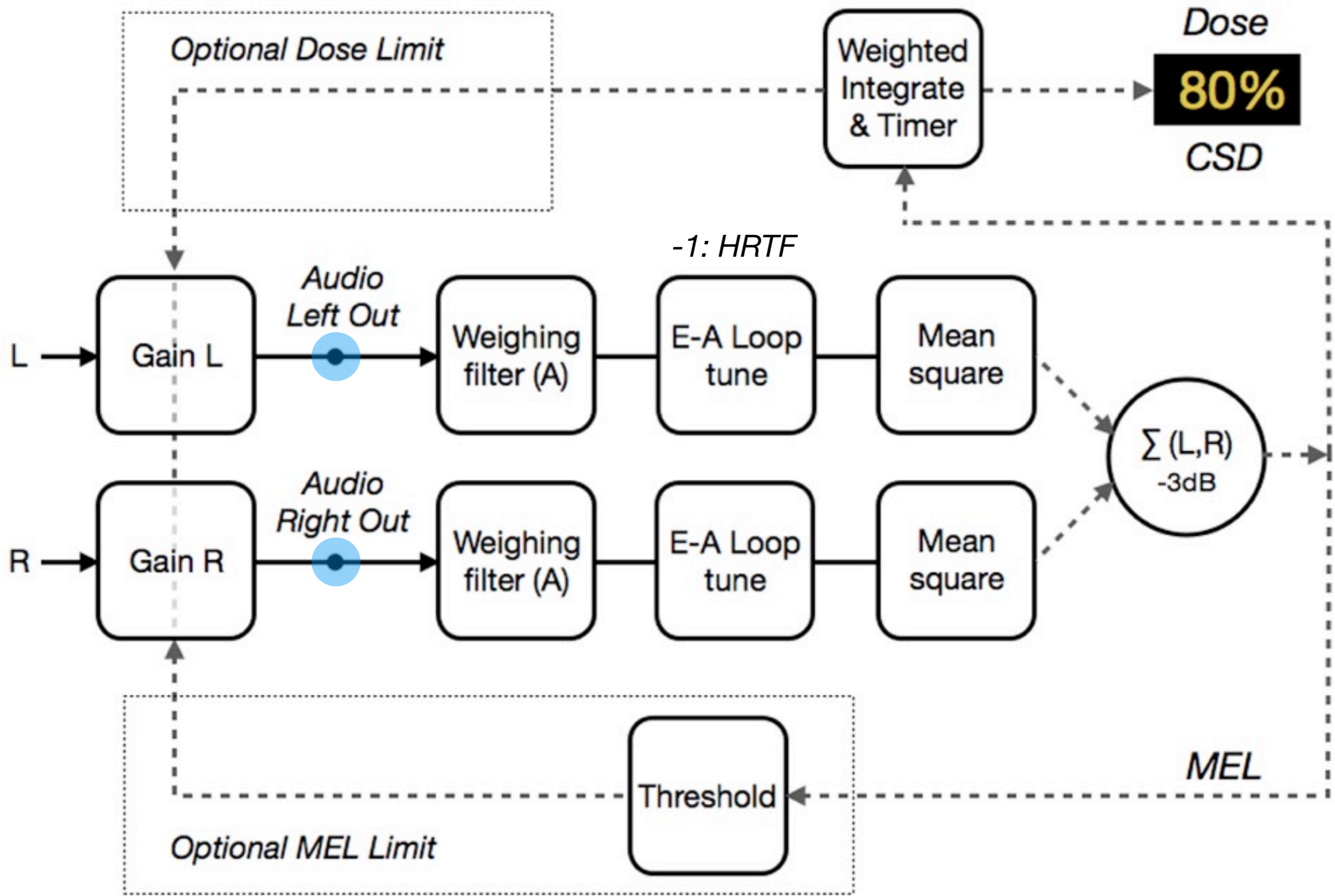

individual

i
n
t
e
r
i
o
r

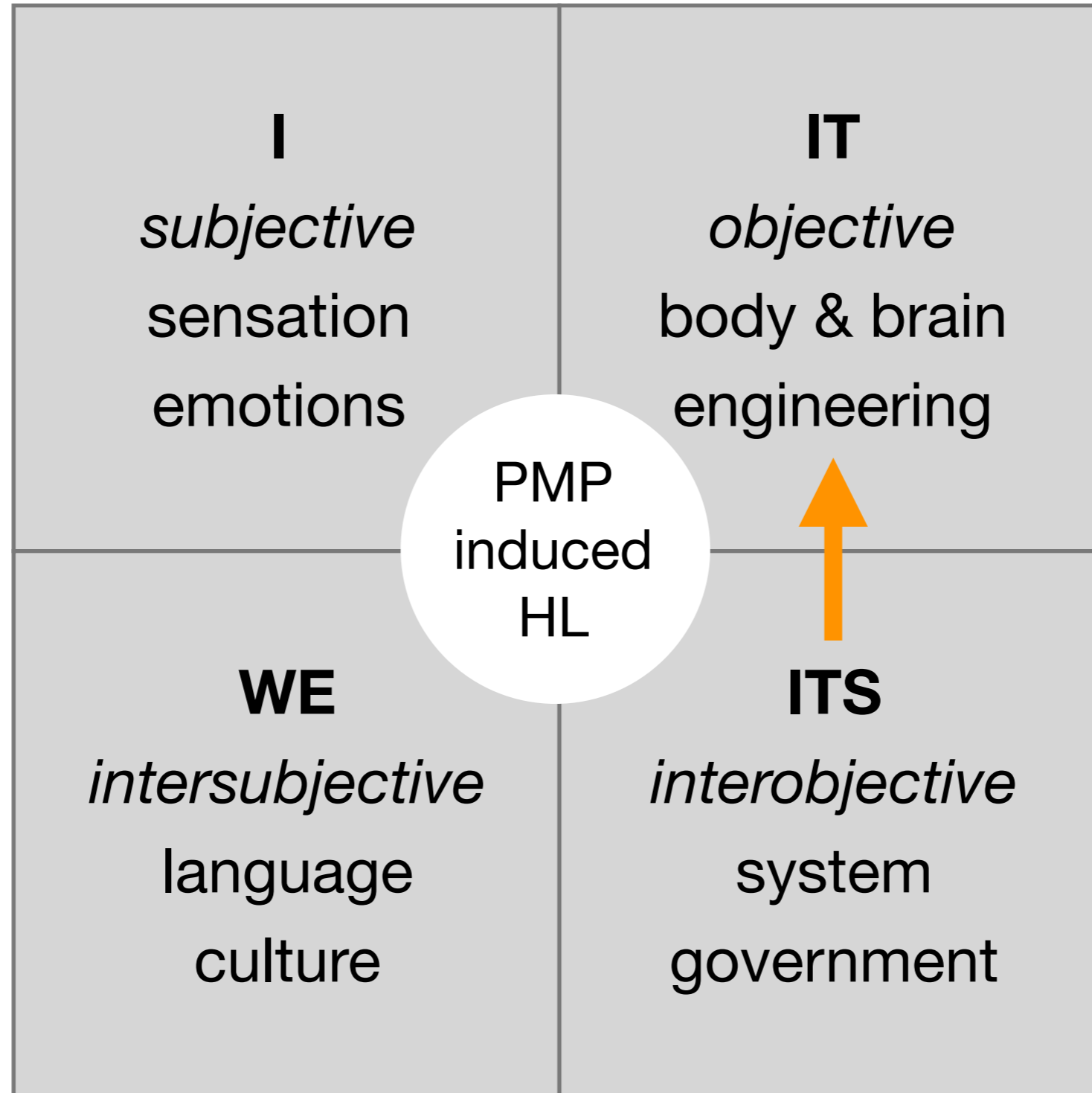

e
x
t
e
r
i
o
r

collective



1.

Count Basie w/Joe Williams:
“Mean Old World”
Secret stereo recording
by Bruce Swedien
1958

2.

Imagine Dragons:
“Demons”
From album
Night Visions
2012



streaming

streaming

Conclusions

Well indicated to legislate on sound exposure from PMPs and VR before we know it

Europe

has had mandatory requirements since 2013 (phase 1, 2)

TC108X/WG3 is making progress on dose estimation (phase 3)

Dose estimation to reduce false warnings, to protect music heritage

Currently, exposure uncertainty can be 30 dB or more (1000 times)

IEC

Phase 1 and 2 implemented in IEC 62368-1, clause 10.6

 No need for other *international* PMP standards on this issue

References

Details

EU Commission (2009). **On the safety requirements to be met by European standards for personal music players pursuant to Directive 2001/95/EC.**

S. G. Kujawa & M. C. Liberman (2009). *Journal of Neuroscience*. **Adding Insult to Injury: Cochlear Nerve Degeneration after 'Temporary' Noise-Induced Hearing Loss.**

B. Gourévitch et al. (2014). *Nature Neuroscience*. **Is the din really harmless? Long-term effects of non-traumatic noise on the adult auditory system.**

S. Gissel, J.T. Mortensen, S. Juul (2002). *Int J Adolesc Med Health*. **Evaluation of hearing ability in Danish children at the time of school start and at the end of school.**

D. Hammershøi et al. (2015). *AES 58th Conference Paper*. **Dose Estimate by Personal Music Players Based on Weighted Output Voltage.**

T. Lund (2015). *AES 58th Conference Paper*. **Prevention of Hearing Loss from the use of Personal Media Players.**

J. Tønnesvang et al. (2015). *Klim*. **The Four Quadrant Model.**

ITU-R BS.1770, EBU R128

thomas.lund@genelec.com

End