

# HANSER

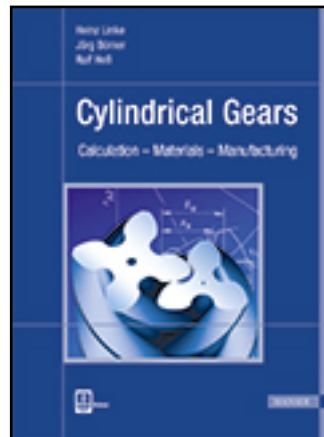

Sample Pages

Cylindrical Gears

Calculation – Materials – Manufacturing

Herausgegeben von Heinz Linke, Jörg Börner, Ralf Heß

Book ISBN: 978-1-56990-489-3

eBook ISBN: 978-1-56990-490-9

**For further information and order see**

<http://www.hanser-fachbuch.de/978-1-56990-489-3>

or contact your bookseller.

Cold rolling has attained a significant importance in discontinuous profile rolling based on the helical principle, also known as the GROB process; see Figure 10.2/4 (Table 10.2/2 number 5).

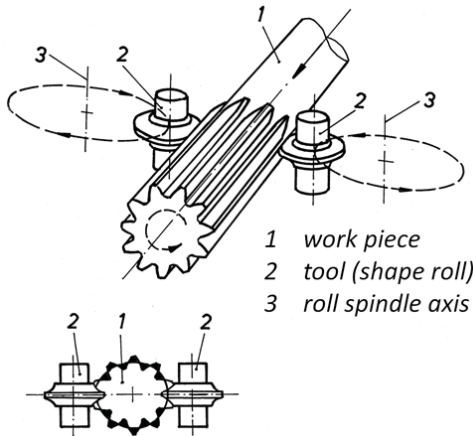

Figure 10.2/4 Axial rolling with forming tools (GROB process) [10.2/103]

In accordance with the generating principle, profile tools in the form of two opposing, eccentrically arranged profile rolls are used. They form the tothing in combination with the axial workpiece feed motion and a planetary tool motion together with a workpiece rotary motion mostly permanently coupled with the gear ratio. As a consequence of this process principle, accuracies in the ISO (DIN) qualities 6 to 8 range are attained. Low tool costs, in combination with high tool lifetimes, result in tool-related costs in the order of a few cents, thus making this process economical even for medium-series production. Tothing deviations can be simply compensated for in tool manufacture (or reworking). The axial flow of the material results in considerable burr formation on the face sides, which is simple to eliminate.

### 10.2.4 Chip-removal Tooth-shape Forming Using Tools with Geometrically Defined Blades

#### 10.2.4.1 Technological Basics

The requirement for chip-removal tooth-shape forming is a relative motion between the workpiece and a V-shaped and wear-resistant tool penetrating into the material. This relative motion consists of the cutting movement, which would result in a one-off chip removal, and the feed motion. In this process, either a repeated or continuous chip removal is achieved. The cutting cross section of a tool blade into the material in the plane, on which the cutting velocity vector  $v_c$  is in a vertical position (refer to Figure 10.2/8), is referred to as the chipping cross section  $A$ , its dimension in the cutting plane as the chipping width  $b$  and in the plane perpendicular to the cutting plane as the chipping thickness  $h$ . The product of the chipping cross section and cutting speed represents the chip-removal rate  $Q_w$  in  $\text{mm}^3/\text{s}$ , the quantity of which represents the productivity of the process. As a first approximation, this chip-removal rate is proportional to the effective chip-removal power  $P_z$  and chipping force  $F_z$ , whose components in the cutting direction are referred to as the cutting force  $F_s$  and – perpendicular to it – as the passive force  $F_p$ . This passive force, in turn, is resolved into the feeding force  $F_v$  and the radial force  $F_r$  (Figure 10.2/5). While the cutting force is the decisive factor for the power of the tool drive, as a result of the working direction oriented to the cutting direction as per

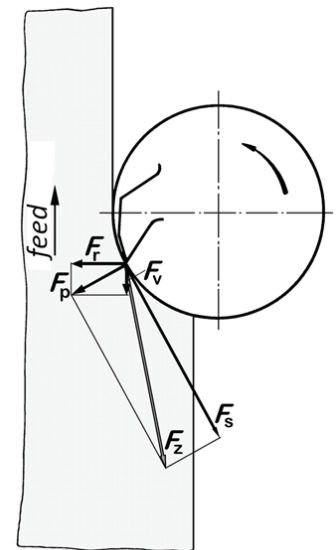

Figure 10.2/5 Blade forces

$$P_s = F_s v_c \tag{10.2/2}$$

where  $P_s$  = cutting power  
 $F_s = f$  (chip cross section, cutting-blade geometry, material, and so on),

the other force components are of particular interest for the purpose of determining the load perpendicular to the workpiece surface causing the effective process deformations and deviations.

The friction between the tool blade and the workpiece material leads to wear marks on the cutting tool blade. These marks have the width  $VB$  on the blade and show a scouring on the cutting face of the tool, along which the separated chip runs off (Figure 10.2/6).

The reasons for these types of wear are the shearing off of pressure-welding particles, mechanical abrasion, scaling and diffusion processes. This order also represents the degree of occurrence with increasing cutting speed and thus cutting temperature (Figure 10.2/7).

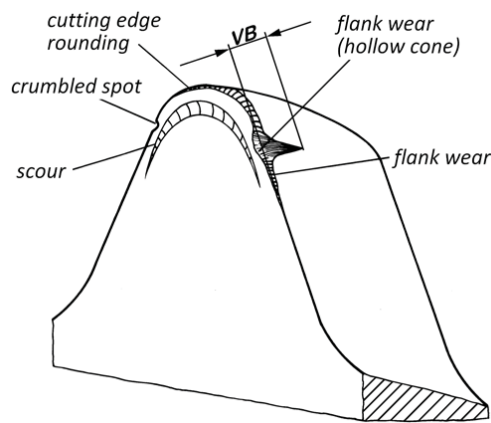

Figure 10.2/6 Forms of wear on the hob tooth

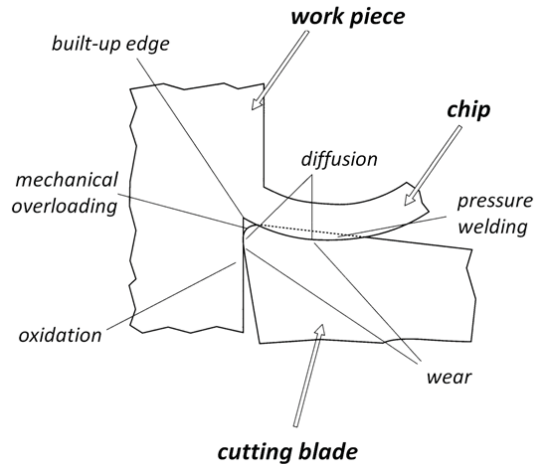

Figure 10.2/7 Causes of wear

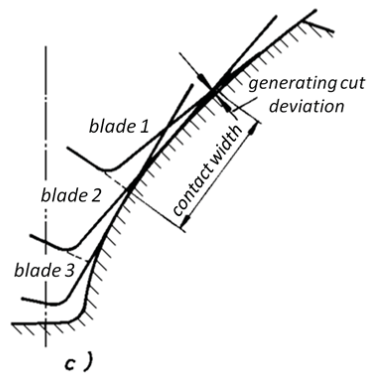
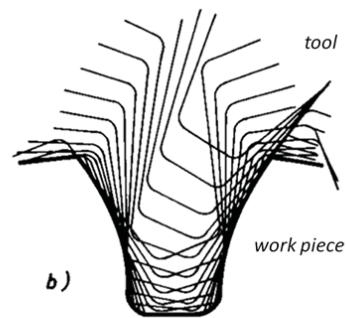
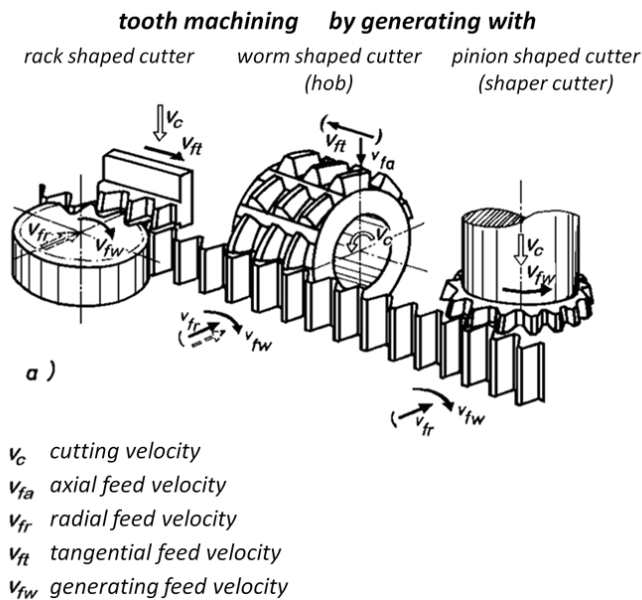

Figure 10.2/8 Manufacturing of tothing by chip removal in rolling processes [10.2/2]: a) process principle; b) tool-workpiece rolling kinematics; c) chipping geometry in rolling processes

In the past, cutting materials have been developed that ever better satisfy the requirements of the chip-removing process and even allow the machining of case-hardened materials with a geometrically defined blade. This requires super-hard materials, which enable the generation of extremely small cutting edge radii in order to keep the relationship between the cutting edge radius and the minimum chipping thickness  $h_{\min}$ , which is about 0.01 mm for chip-removing processes with geometrically defined blades, within the technically acceptable limits of chip removal, thus avoiding excessive chip-removal forces.

The following cutting materials are of importance in gear technology:

- *High-speed steels* (also high-performance rapid steel [HRS]). These are high-alloy steels with hardnesses from 60 to 67 HRC and a tempering resistance up to approx. 600°C. The tempering resistance, hardness and wear resistance are determined by the martensite and the special carbides embedded (particularly Mo-W double carbides, Cr and V carbides).

In contrast to the aforementioned high-speed steels that are manufactured using melt-metallurgical techniques, PM-HRS cutting materials are produced using powder metallurgical processes. These materials generally have a higher alloy content, while their fineness of grain, high degree of purity, the uniform distribution of the carbides as well as the lack of segregation provide further benefits. The ductility of the material resulting from the high degree of purity makes it particularly suitable for gear technology applications with geometrically complicated tools subjected to abrupt loads, such as hobs, shaper cutters and shaving cutters.

- *Hard metals* are sinter materials and consist of special carbides (WC, VC, TiC, TaC and NbC) embedded in a bonding phase. Compared to high-speed steels, the hard metals offer a higher degree of hardness and thermal stability thanks to their high hard-material content (70–95%). Although from a technical chip-removal perspective they are beneficial at cutting temperatures up to 1000°C, these benefits can be reduced due to the risk of diffusion and the low bending strength. Attempts have been made to compensate for these disadvantages by the use of smaller

grain sizes, particularly for gear cutting tools. Hard metals containing ultra-fine grains (grain size from 0.4 to 0.5  $\mu\text{m}$ ) have a strength some 30% higher than the standard grain size (0.9 to 1.4  $\mu\text{m}$ ).

As a consequence of their limited machinability compared to high-speed steels, they are particularly used in the manufacture of inserts, soldered or clamped into the main tool body, with two to four blades on the edges. When using inserts, the maximum four possible blades can be used in succession by turning the cutting inserts on the main body, provided that this is not prevented by geometrical reasons, such as an unsymmetrical blade design in association with modified gear tooth profiles (Figure 10.2/9). In this regard, similar tools (such as hobs) also differ as to whether they are designed with high-speed steels or hard-metal steels. In a similar manner to high-speed steels, the wear resistance of hard metals can be improved with a surface coating applied by means of the CVD technique, due to the lack of structural transformation.

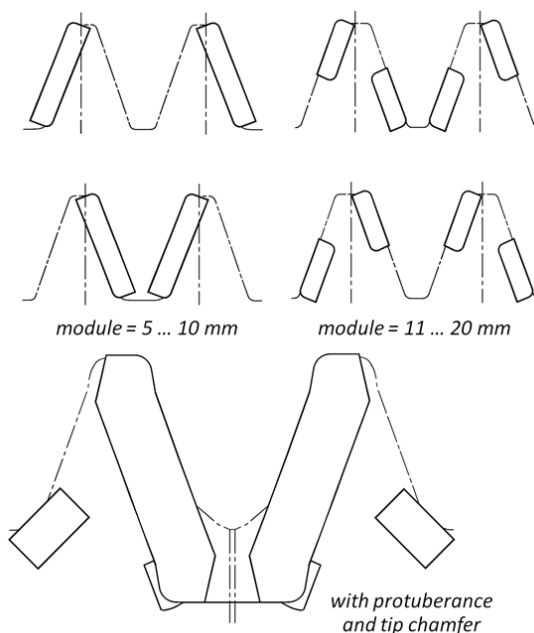

Figure 10.2/9 HM cutting inserts on hobs [10.2/106]

- *Polycrystalline boron nitride (PKB)*. After diamond, this is the hardest available material (cubic boron nitride) and is used at the present time as a cutting insert in a limited dimensional range or on hard-metal supporting plates. Despite its extremely high impact sensitivity, this cutting material can be used for the machining of hardened steels in finishing conditions.

The *machinability* depends largely on the pairing of cutting material, basic material, and auxiliary substance. As a result of the only limited influence on the chipping force, the machinability is mainly measured by means of the wear characteristics. It is recommended to use the cutting speed as the control variable because this represents the parameter with the highest dependence. In this regard, its size is corrected in the process design by the value of the relative machinability.

The *production accuracy* for chip-removal processes is characterised by the following principles [10.2/44], [10.2/45]:

- The generation of the toothing ensues by means of discrete cutting blades and individual cuts, whereby the theoretical flank surfaces are approximated by a succession of individual lengths (per cut) of the geometric tool blade-flank surface pair engaged. Depending on the position of the main feed motion (the principal component of the complex feed motion), this results in process-related profile deviations generated when approximating the profile (main feed motion in the flank direction, e.g., in shaping) or infeed meshing marks in the flank direction (principal component in the involute direction, e.g., in hobbing) (Figure 10.2/10).
- For rolling, helical pitch, and general screw rolling processes, the rolling kinematics require a mechanical generation via an appropriate drive that – in the case of its electronic design – contains mechanical links, which generate an inevitable profile form deviation occurring as waviness in the profile. Their wave number corresponds to the ratio of the length of the path of contact to the base pitch multiplied by the relation derived from the interference frequency and the tool rotational frequency.

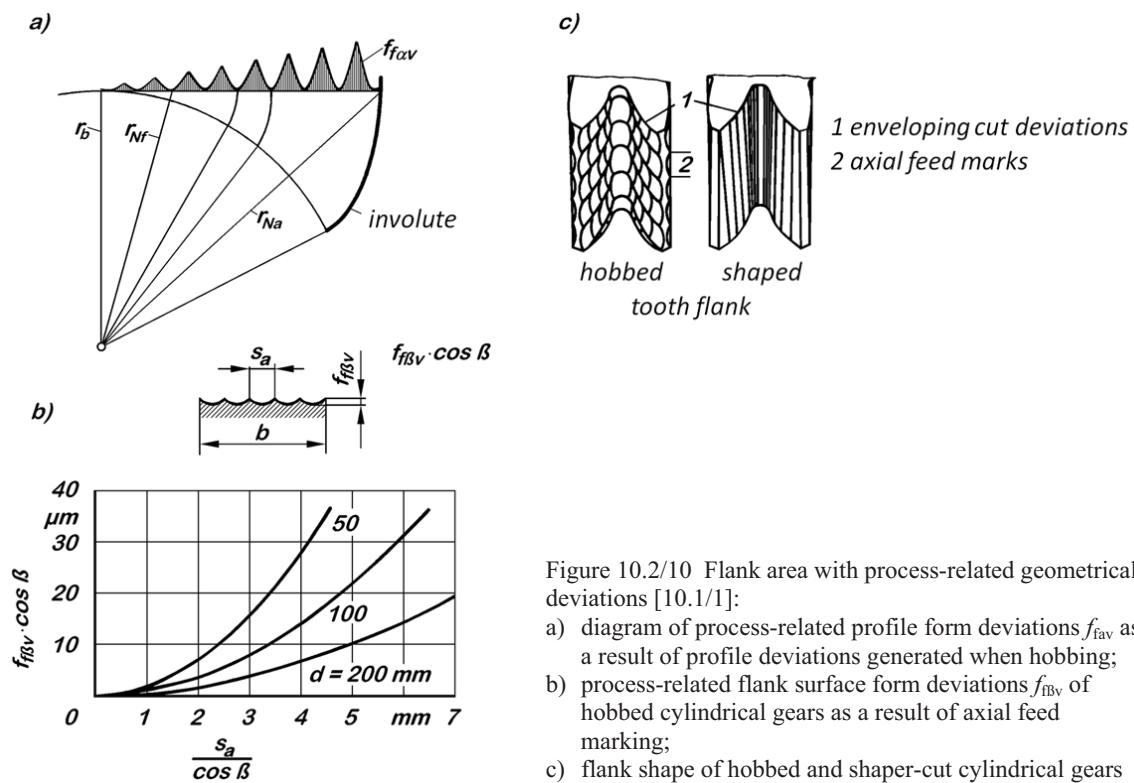

Figure 10.2/10 Flank area with process-related geometrical deviations [10.1/1]:

- diagram of process-related profile form deviations  $f_{fav}$  as a result of profile deviations generated when hobbing;
- process-related flank surface form deviations  $f_{fBv}$  of hobbed cylindrical gears as a result of axial feed marking;
- flank shape of hobbed and shaper-cut cylindrical gears

- The tool with its functional surfaces deviating in flank and tip clearance angle, as well as its flank and tip rake angle from the basic rack in the face width direction, has the design profile in one plane only. Inaccurate positions of the free surfaces or cutting faces thus lead to differences between the actual and nominal cutting position, which result in deviations of the workpiece toothing (for example, refer to Figure 10.2/11).
- The tool wear in the form of wear marks leads directly to an offset of the actual cutting position compared to the nominal cutting position and – in the form of crater wear via the orthogonal clearance angle – leads directly to a change in the cutting position compared to its rolling or nominal position required based on the helical principle. So both forms of wear cause wear-related deviations of the toothing, which, in turn, may lead to different deviations depending on the type, position and uniformity of the wear formation.
- Under the effect of the chipping force associated with the chipping process and its component perpendicular to the surface, tool-fixture-workpiece deformations arise due to the finite stiffness of the tool machine system, which lead to systemic deviations depending on deformation size and uniformity along the line of contact (example: skiving).
- Along with those deviations caused by chipping-related technical reasons, the generally applicable principles relating to the influence of the precision of the tool, its clamping, the datum surfaces and the accuracy of the workpiece clamping also have an effect, leading not only to runout and cumulative pitch deviations but also to a wobble of the profile and of the tooth trace on the workpiece circumference (Figure 10.2/12).

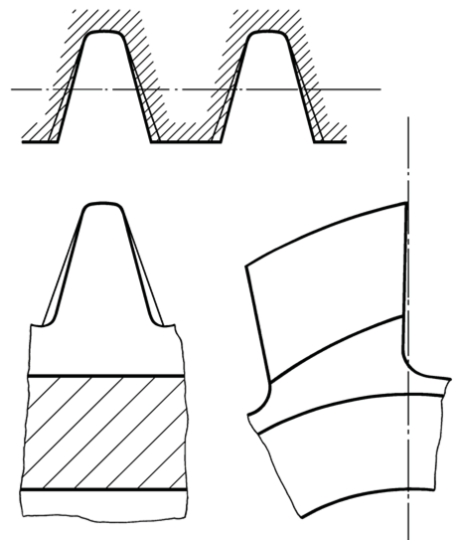

Figure 10.2/11 The influence of geometrical deviations of the tool on the toothing accuracy for a hob with wrongly negative cutting angle on the tip blades

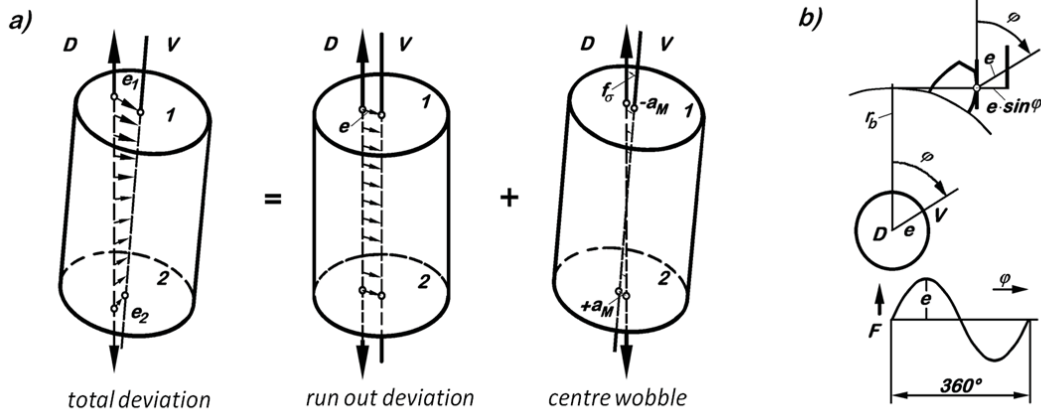
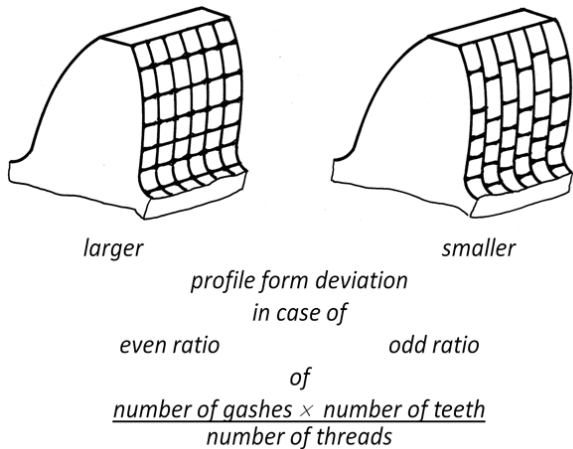

Figure 10.2/12 Workpiece eccentricity as per [10.2/1]: a) clamping deviations of a wheel; b) effects of an eccentricity  $e$  on profile, tooth trace and pitch

- Chipping processes are based on a discontinuous (indexing after cutting of a tooth space) or continuous (toothing pitch stored in the tool) process principle. Whereas with the single-pitch process the indexing accuracy of the tool machine determines the accuracy of the circular



pitch, with continuous processes it is primarily dependent on the tool-pitch accuracy. Multiple-start, worm-shaped gear cutting tools in particular (e.g., hobs) exhibit greater deviations, which in the event of integer divisibility of the number of teeth of the workpiece by the number of starts result in pitch and profile form deviations (Figure 10.2/13).

Figure 10.2/13 Profile form deviation of the tooth flank with multiple-start hobbing

### 10.2.4.2 Plane by the Generating Method

Generating planing (Table 10.2/2 number 6), from its technical process and gear principles involved – namely the plane/shaping process and the rack-cylindrical gear rolling principle – represents a chipping process with simple process-engineering geometry and kinematics as well as manageable principles. It is therefore not surprising that this process was developed as far back as 1913 by the Swiss MAAG Company and has proven its worth over many decades, particularly in the manufacture of large gear units in the form of single-unit production (Table 10.2/2 number 6). The constant further refinement and increasingly better mastering of the hobbing process, including the development of ever more complicated – but also more powerful – hobbing tools, has resulted in less importance of generating planing. Generating planing is suitable not only for spur and helical gears but also for chain wheels, splined shafts as well as other machine elements with profiles that can be rolled. It represents an universal process, albeit with a lower productivity, suitable also for gears with small space for tool overrun.

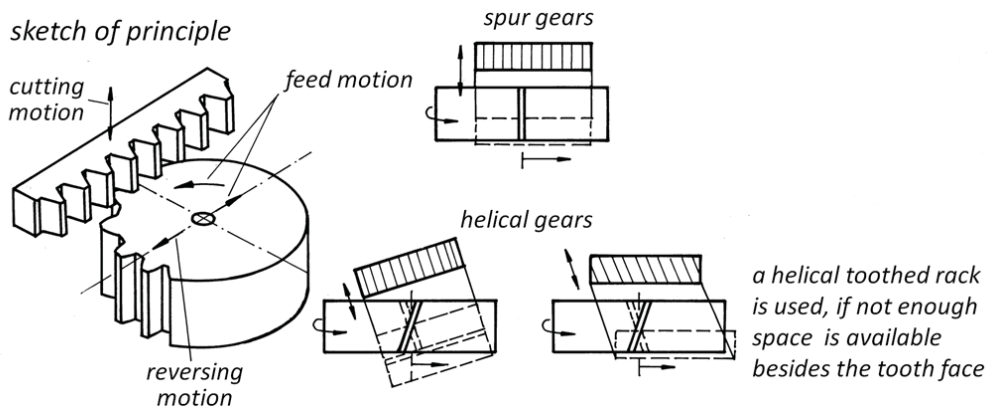

Figure 10.2/14 Generating planing process principle [10.2/103]

The reason for the low productivity is the fact that the return stroke of the rack tool has to be performed as an idle cut, and the generation of the stroke sets mechanical engineering limits with regard to the stroke rates attainable.

It is, of course, possible to work with generating process machines by not including the rolling motion in the profiling process, thus also allowing the manufacture of internally toothed gears.

The generating planing process principle corresponds to the rolling-off of a cylindrical gear on a rack, whereby the rack is embodied by the tool geometry in the cutting face, including the cutting motion (Figure 10.2/14). The cutting motion is carried out in the form of a stroke by the rack-type cutter (several planing teeth in parallel) or by the single tooth planing tool, so generating planing represents a shaping process in the technical chipping sense as a result of the moved tool. The teeth of the rack-type tool are relieved at the flanks to achieve the clearing angle necessary from a chipping technical perspective (to avoid friction on the flanks) and to contain a grinding of the cutting face on the face, which can be identical with the cutting face, in order to achieve a favourable chip removal. As this cutting face grinding results in geometrical deviations from the nominal face of the tothing, an appropriate correction of the tool profile, which otherwise corresponds to the basic rack, is necessary, taking into account the angles at the planing tooth [10.2/50]–[10.2/52]. The relatively uniform chipping force and the diverse possibilities to influence its size and progress along the rolling path are what makes it possible to achieve a relatively high degree of precision using the generating planing process, attaining a quality of 5 (4) in accordance with ISO 1328 (DIN 3962/63).

### 10.2.4.3 Gear Shaping

Gear shaping (Table 10.2/2, number 7) is a continuous gear cutting process that operates according to the generating principle. Consequently, in the case of cylindrical gearing, the axes of the workpiece and the tool are coaxial in space. A spur or helical shaper cutter is used as the tool, the teeth of which are relieved in order to obtain the relief angle at the flanks and the tooth tip that is required for the chipping process [10.2/53]. During the chipping process, the tool and workpiece intermesh analogously to the meshing in the transmission, which results in a combined feed motion for the purpose of chipping.

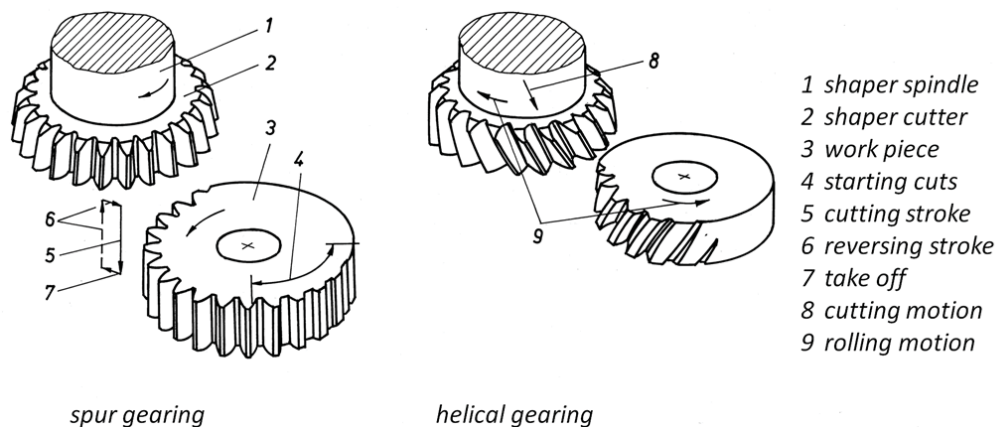

Figure 10.2/15 Process geometry and kinematics of gear shaping (Note: ram stroke/shaping amplitude is in the  $z$  direction)

Due to the relief grinding of the shaper cutter teeth and in order to produce the cutting motion, the shaper cutter performs a stroke motion, which is superimposed on a rotary motion in the case of helical gears (Figure 10.2/15). The stroke motion in the  $z$  direction in combination with the rotary motion is performed by the ram of the machine, which contains the so-called lead cartridge for realizing the helical motion. This guide cartridge, which is interchangeably mounted in the machine, has a helical guide groove of a constant lead  $H$  for the tappet. The combined feed motion resulting from the rolling motion is generated through the kinematic coupling of the rotary motion of the workpiece and shaper cutter.



Conventional gear shaping machines are equipped with a mechanical transmission, in which the coupling of the generating motion between the shaper cutter and workpiece is produced by change gears. Modern gear shaping machines use CNC controls, which not only eliminate the costly exchange of the change gears but, due to the performance of the computerised control systems, enable multiple tasks to be carried out, thus increasing the flexibility and efficiency of these shaping machines.

The ram motion is generally generated via a crank drive so that the cutting motion is variable due to the adjustable stroke length. The disadvantage of the non-uniform speed along the stroke length of the mechanical crank drive can be avoided with an additional crank drive.

With this design solution, the operating speed is reduced to about 70% of the maximum speed, but it is kept constant over almost the entire stroke length while the maximum return stroke speed is increased by approximately 40% (Figure 10.2/16). The required stroke length results from the face width and the starting and overrun path of the blades of the shaper cutter on the workpiece face.

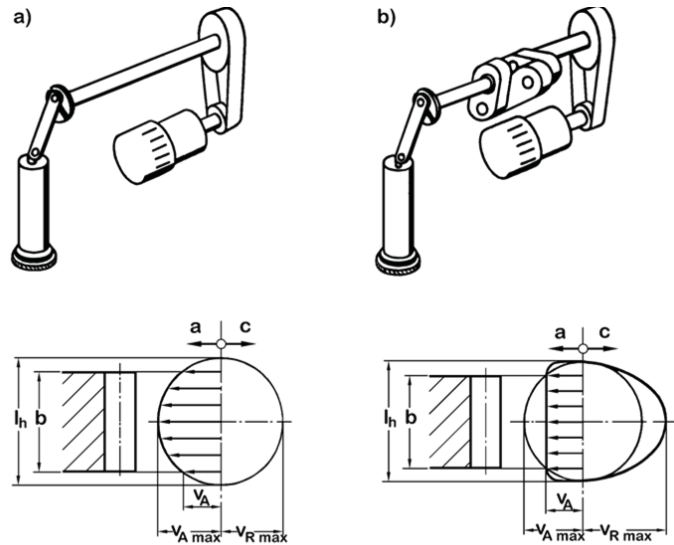

Figure 10.2/16 Gear shaping: a) normal stroke drive, b) drive for constant cutting speed;  
 $a$  = working stroke,  $b$  = face width of wheel,  $c$  = return stroke,  
 $l_h$  = stroke length,  $v_A$  = tool speed in working stroke,  
 $v_{Amax}$  = max. tool speed in working stroke,  
 $v_{Rmax}$  = max. return stroke speed

For spur workpieces, the stroke length  $l_h$  is

$$l_h = 1.14 \cdot b \tag{10.2/3}$$

and for shaper cutters with step cut for helical workpieces

$$l_h = \frac{b}{\cos\beta} + (0.6 \text{ to } 1.0) m_n \cdot \sin\beta + \frac{b}{14} \tag{10.2/4}$$

with  $b$  face width  
 $\beta$  helix angle  
 $m_n$  normal module

Compared to the other manufacturing methods of gears, shaping requires a small distance to the adjacent flanges. This property and the generation principle of gear shaping resulted in the typical application areas of the method (Table 10.2/2, number 7.):

- internal straight cylindrical and helical gears,
- external straight and helical cylindrical gears, while ensuring a low tool overrun (such as block wheels and switching shafts in vehicle transmissions),
- racks,
- special gearing such as tooth segments, crown wheels, gear hubs, spline shafts, sprocket wheels, among others.

Thus, gear shaping is the cutting method most commonly used after hobbing. The design of the shaper cutter depends on the workpiece geometry and the cutter arbor of the spindle of the gear shaper. In principle, distinctions are made between (DIN 1825, 1826, 1828, 1829; refer to Annex 15.1)

- *disc shaper cutters* for external gearing and large internal gearing with sufficient tool runout for the fastening nut,
- *bell-type shaper cutters* for external and large internal gearing, where there is a risk of collision of the workpiece and the fastening nut of the shaper cutter, and
- *shank shaper cutters* with tapered shank for internal gearing with a small reference diameter.

Shaper cutters as solid shaper cutters are commonplace, where high-speed steel dominates as the cutting material. In order to improve the cutting ability and tool life (total cutting time between two required regrindings), shaper cutters are surface treated and PVD coated in particular. Regrinding is done on the cutting face (facial normal plane of the tool) and causes on one hand a reduction of the usable length of the tool and so by the relieving of teeth to a change of the profile shift, and on the other hand to a change of the edge-holding capacity of the shaper cutter.

Other than on the machinability of the workpiece material, the applicable cutting parameters mainly depend on, among others, the parameters of the chipping process, such as the pairing of the cutting material, workpiece material, and auxiliary substance, and the geometric intersection per stroke between the shaper cutter and workpiece. That means the wear-tool life performance of the shaper cutter is decisive for the productivity of the process. In this respect, the process design is subject to continuous development [10.2/54] to [10.2/62].

In the case of gear shaping, there is a disadvantageous machining process at the tip edge to the trailing pinion cutter flank because the smaller chipping thicknesses at the trailing pinion cutter flank lead to material hold-up and consequently to increased wear. Special improvements in the design of the cutting process could be achieved by computer-aided control of the machining process. A continuous but degressive infeed while rolling several revolutions of the workpiece at a high generating feed allows for a remarkable increase in performance when the requirements of high rigidity of clamping of workpiece, tool, and machine tool are met. Another increase of machining power is possible by implementing the controlled cutting process (CCP). This method allows for the design of optimized machining data (number of strokes, radial infeed, generating feed), while a more uniform chip is formed from leading to trailing flank. The chip formation is controlled and will increase cutter life (Figure 10.2/17). The CCP requires high rigidity and dynamic load capacity of the machine. At the same time, the more advantageous cutting conditions lead to improved toothing accuracy, which is limited in the case of conventional cutting conditions, particularly due to the influence of the springback between tool and workpiece during the completion of a cut (revolution). Springback is caused as a result of the roll-out of the shaper cutter in the roll-in area, and the resulting reduction in cutting force. When using the CCP method in

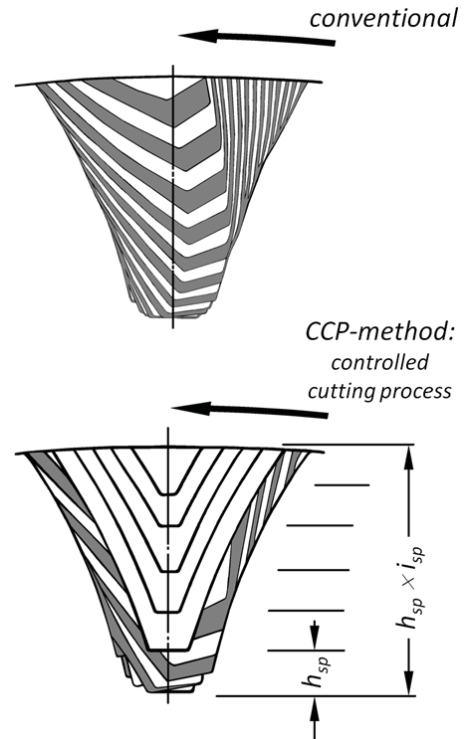

Figure 10.2/17 Comparison of chip cross sections in the conventional and the CCP method;  $h_{sp}$  = radial infeed per workpiece revolution;  $i_{sp}$  = number of workpiece revolutions

conjunction with shaper cutters coated in titanium nitride, it is possible to achieve the quality 6 to 7 according to ISO 1328 (DIN 3962) while maintaining a surface roughness of  $R_z < 10 \mu\text{m}$ . This has particular importance mainly in the manufacturing of internal gearing with subsequent nitriding, because finishing in order to improve the accuracy or the surface quality can be very costly.

**10.2.4.4 Skiving**

Skiving corresponds to the pairing of shaper cutter and workpiece, but both perform a continuous rotary motion, and the tool also executes a continuous feed motion in the axial direction (Table 10.2/2, number 8). It is a working cutting method by chip removal according to the helical pitch principle that was invented at the beginning of the last century (Figure 10.2/18). However, it has only been ready for application in recent decades because there are extraordinary requirements for the accuracy and rigidity of the machine and tool, including the clamping [10.2/64]. Today, skiving is a highly productive method for the machining of external and internal gearing. As a special variant of the method, the method in the form of hard skiving is also suitable for the machining of case-hardened gears with small dimensions.

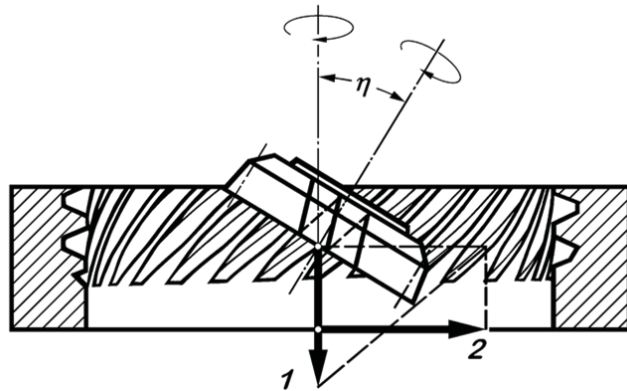

Figure 10.2/18 Skiving

The sum of the helix angle of the tool ( $\beta_0$ ) and workpiece ( $\beta_2$ ) are in the range

$$0^\circ \leq \eta = \Sigma_0 = | \beta_0 + \beta_2 | \leq 90^\circ \tag{10.2/5}$$

Prefix rule:

External gearing:	right-handed	+
	left-handed	-
Internal gearing:	right-handed	+
	left-handed	-

Thus, the cutting edges of the skiving wheel also move in the lead direction of the tooth so that chip removal can be carried out. Consequently, the components of the relative motion between tool and workpiece resulting from the method principle, in the form of the feed motion (1) and the additional differential rotation (2) (Figure 10.2/18), are in fixed proportion to each other. Only the axial feed motion results as an independently selectable motion component.

The skiving wheel corresponds to a spur or helical gear with a cylindrical or conical outer contour, whereby the conical outer contour has the required relief angle for the chipping process. In order to achieve an effective clearance angle, the cylindrical skiving wheels must have a cutting face offset from the axis-crossing point. Generally, skiving wheels are executed in a step cut analogous to the shaper cutters of the gear-shaping method in order to produce cutting-edge geometries that are advantageous for the chipping process. The cutting face lead angle generally corresponds to the helix angle of the skiving wheel  $\beta_0$ . With regard to the rolling kinematics, because the individual points of the cutting edges do not meet the meshing conditions for a deviation-free rolling action, corrections of the involute geometry of the skiving wheel are inevitable. The *achievable accuracy*

when skiving non-hardened gearing is in the quality range 7 to 8 in accordance with ISO 1328 (DIN 3962/63) and at quality 6 for hard skiving with carbide skiving wheels.

### 10.2.4.5 Hobbing

Hobbing (Table 10.2/2 number 9), a gear rough-machining and gear-finishing process of external and internal gears as well as other rollable profiles, invented in 1897 by *Pfauter* in Chemnitz based on preliminary work by *Schiele* (1856) and *Grant* (1887), represents the predominant process for manufacturing cylindrical gears, being suitable both for the highly productive pre-machining and finishing of non-hardened gears and – in its special form of skiving – for the finishing of case-hardened gears (Figure 10.2/19). It encompasses the dimensional range of gears from a few millimetres up to ten metres and a range of moduli from  $m = 0.1$  to 50 mm. Its advantages include not only a high degree of flexibility but also high productivity, while past experience has shown this process to be continually evolvable.

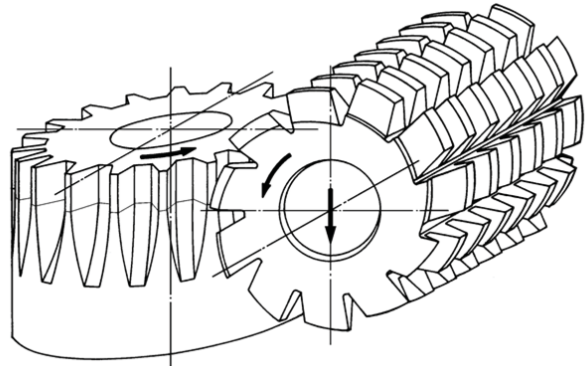

Figure 10.2/19 Hobbing a cylindrical gear

For the manufacture of cylindrical gearing units, this process principle corresponds to the hobbing chipping method and the helical pitch principle (Figure 10.2/1b). In this process, the tool is embodied by a cylindrical worm, whose normal section corresponds to a basic rack which is moved in the direction of the tooth by means of a component of the feed motion, so that the counterpart rack is enveloped from the basic rack of the hob and the feed motion component. The swivel angle of the hob  $\eta_0$  is derived according to the generating principle from the geometry of the tool and the workpiece and is given by

$$\eta_0 = \beta \pm \gamma_0 \tag{10.2/6}$$

where  $\beta$  is the helix angle,  
 $\gamma_0$  is the lead angle of the hob;  
 lower sign (-) with the same lead direction,  
 upper sign (+) with the opposite lead direction of tool and workpiece

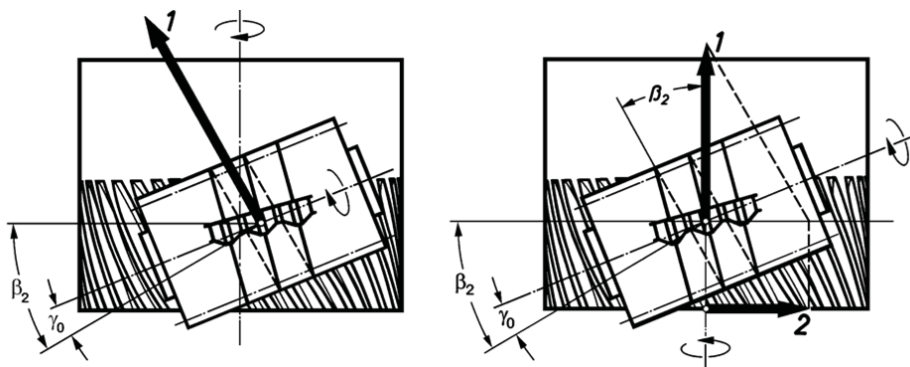

Figure 10.2/20 Method according to Grant

Method according to Pfauter