

# M-1115S-Methanol Pump

## Owner's Manual



**DO NOT RETURN THIS PRODUCT TO THE STORE!**

Please contact GPI before returning any product. If you are missing parts or experience problems with your installation, our **Customer Support Department** will be happy to assist you:

**800-835-0113** or  
**316-686-7361**

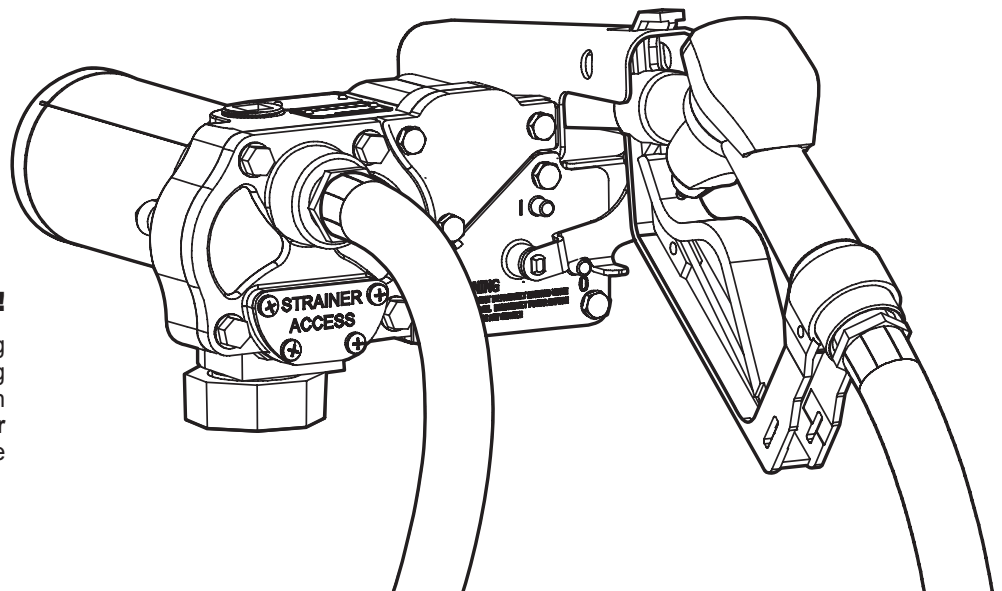

### TABLE OF CONTENTS

General Information.....	2
Safety Instructions.....	2
Installation.....	2
Operation.....	3
Maintenance.....	4
Repair.....	4
Troubleshooting.....	8
Illustrated Parts Drawing.....	9
Specifications.....	10
Parts and Service.....	10

**To the owner...**

Congratulations on receiving your GPI fuel pump. We are pleased to provide you with a system designed to give you maximum reliability and efficiency.

Your fuel pump is designed, tested, and approved for use with gasoline, methanol, ethanol, diesel fuel (up to 20% biodiesel) and kerosene. Please take all due precautions when handling these flammable liquids. Your safety is important to us.

Also, to assure the longest possible service life, it is important that you follow the operation and maintenance procedures outlined in this manual. We are proud to provide you with a quality product and dedicated support. Together with your conscientious use, we are sure that you will obtain years of safe, dependable service.



Great Plains Industries, Inc. is a member of the Petroleum Equipment Institute.

Victor Lukic, President  
Great Plains Industries, Inc.

## GENERAL INFORMATION

The purpose of this manual is to assist you in installing, operating and maintaining your GPI pump. This manual covers the 120-volt AC electric gear pump, model M-1115S-Methanol.



The pump should be connected to a 120-volt AC power source.

**An automatic bypass valve prevents pressure build up when the pump is on with the nozzle closed. To avoid damage, do not run the pump more than 10 minutes with the nozzle closed.**

The duty cycle of this pump is 30 minutes ON and 30 minutes OFF. Allow the pump to cool for 30 minutes.

This pump is specifically designed for use with methanol and ethanol. The pump is also compatible with gasoline, diesel fuel (up to 20% biodiesel blends such as B20) and kerosene. **Do not** use this pump for dispensing any fluids other than those for which it was designed. To do so may damage pump components and will void the warranty.

The pump is designed to operate with the appropriate AC voltage at the motor leads and the ratings are determined at this voltage.

Do not leave the system running with fluids. "Dry running" can damage the pump.

Do not pump the tank completely dry, as contaminants from the bottom of the tank may enter the pump.

## SAFETY INSTRUCTIONS



The following safety alert symbols are used in this manual. Obey all safety messages that follow this symbol to avoid possible injury or death.

### DANGER

**DANGER** indicates a hazardous situation which, if not avoided, will result in death or serious injury.

### WARNING

**WARNING** indicates a hazardous situation which, if not avoided, could result in death or serious injury.

### CAUTION

**CAUTION** indicates a hazardous situation which, if not avoided, may result in minor or moderate injury.

It is your responsibility to:

- know and follow applicable national, state, and local safety codes pertaining to installing and operating electrical equipment for use with flammable liquids.

- know and follow all safety precautions when handling petroleum fuels.
- insure that all equipment operators have access to adequate instructions concerning safe operating and maintenance procedures.

Observe all safety precautions concerning safe handling of petroleum fuels.

To ensure safe operation, all fuel transfer systems must be properly grounded. Proper grounding means a continuous metal-to-metal contact from one component to the next, including tank, bung, pump, meter, filter, hose and nozzle. Care should be taken to ensure proper grounding during initial installation and after any service or repair procedures. For your safety, please take a moment to review the warnings below.

To prevent physical injury, observe precautions against fire or explosion when dispensing fuel. Do not operate the system in the presence of any source of ignition including running or hot engines, lighted cigarettes, or gas or electric heaters.

Observe precautions against electrical shock when operating the system. Serious or fatal shock can result from operating electrical equipment in damp or wet locations.

Inspect external pump wiring regularly to make sure it is in good condition. To avoid electrical shock, use extra care when connecting the pump to power.

Avoid prolonged skin contact with petroleum fuels. Use protective goggles, gloves and aprons in case of splashing or spills. Change saturated clothing and wash skin promptly with soap and water.

Observe precautions against electrical shock when servicing

the pump. **Always** disconnect power before repairing or servicing. **Never** apply electrical power to the system when any of the coverplates are removed.

If using solvent to clean pump components or tank, observe the solvent manufacturer's recommendations for safe use and disposal.

## INSTALLATION

This pump is designed to self-prime with dry gears. Expect suction lift as follows:

Manual Nozzle: 5.5 feet (1.7 m) with diesel  
6.7 feet (2.1 m) with gasoline

Automatic Nozzle: 4.8 feet (1.5 m) with diesel  
5.8 feet (1.8 m) with gasoline

If you require a greater initial prime height, coat the gears with fluid by removing the plug on the top of the pump and pour a small quantity of motor oil into the gear cavity. Replace the plug and try again. A foot valve with pressure relief may be needed to maintain prime.

## Install Bung Adapter and Suction Pipe

Make sure all threaded fuel connections are wrapped with three to four turns of thread tape or a pipe sealant approved for use with petroleum fuels.

- Tighten the bung adapter snugly on the fuel tank.
- Place the union ring gasket into the inlet fitting on the bottom of the pump.
- Thread the suction pipe into the inlet fitting and tighten until snug.

## Install Pump on Tank

- Clean the tank interior of all dirt and foreign material.
- Extend the suction pipe to its full length and insert into the tank opening. (Figure 1)

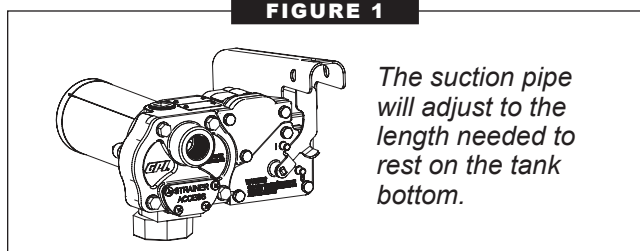

- Place the pump on the bung adapter and tighten the union ring securely with a pipe wrench. Make sure the union ring is not cross-threaded.

NOTE: To prevent pressure buildup and possible fuel leaks through the nozzle, make sure the tank is vented. A vent cap rated at 3 psi or less is recommended.

## Install Electrical Connections

This pump is designed for use with 120-volt power. Do not attempt installation on 12-volt, 24-volt, or 230-volt power sources.



It is important to exercise more than ordinary care with electrical installation and maintenance. Failure to follow these electrical connection instructions could result in death or serious injury from shock, fire, or explosion.

Electrical wiring and connections must be made only by a licensed electrician in accordance with national, state, and local electrical codes regarding Class I, Division 1 requirements as well as NFPA Code 70 and 30. Other codes may apply.

Install UL Listed, rigid metal conduit and code-specified gas-oline and oil-resistant wire with ground wire from the switch box to the pump electrical box and use proper seal offs.



- Remove the electrical coverplate. (Figure 2) Be careful not to damage gasket.

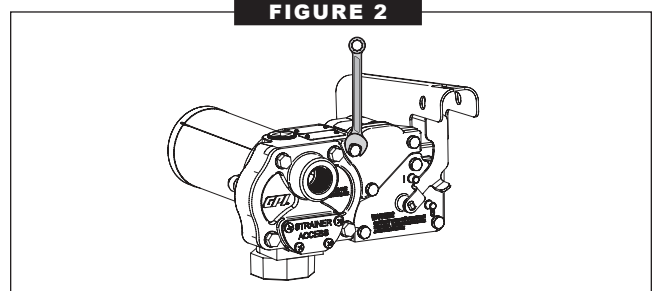

- Route the wiring and conduit to the pump.
- Attach the ground wire to the pump's green ground wire.



- Attach wiring to pump wires.
- Position all wires inside the pump's electrical cavity.
- Replace the electrical coverplate.

## Install Hose and Nozzle

NOTE: If installing accessories such as flow meters or filters, do so now, following the manufacturer's instructions.

After sealing the threads, tighten the hose into the pump outlet and the nozzle on the hose. The nozzle can be placed in the nozzle hanger only when the pump is off.

NOTE: The nozzle holder allows the pump to be locked when the nozzle is in place.

## OPERATION

**ALWAYS FOLLOW SAFETY PRECAUTIONS WHEN OPERATING THIS EQUIPMENT. REVIEW THE SAFETY INSTRUCTIONS.** Before each use, repair leaks around seals or connections. Make sure hoses are in good condition and connections are tight. Make sure the work area is dry. **MAKE SURE THE PUMP IS PROPERLY GROUNDED.** Repair any corroded or damaged wiring before use. Ensure the tank contains enough fuel. Make sure the fuel is not contaminated with debris.

## Dispense Fuel

Turn the pump on by removing the nozzle from its holder and pushing up the switch lever. Insert the nozzle into the receiving tank and squeeze the handle to start fuel flow. When done, release the nozzle handle, turn the pump off, and return the nozzle to its holder.

This pump is designed to be self-priming. If fuel is not delivered within 15 to 20 seconds, turn the pump off and refer to the priming information in the Troubleshooting Section.

An automatic bypass valve prevents pressure buildup when the pump is on with the nozzle closed. To avoid pump damage, do not run the pump for more than 10 minutes with the nozzle closed.

## Auxiliary Temperature-Limiting Device

The motor is provided with an internal auxiliary temperature-limiting device. Excessive motor heat can trip the device. It resets automatically after the motor has cooled approximately 30 minutes.

## Circuit Breaker

The magnetic circuit breaker trips automatically when the motor draws more than 2.5 amps. This feature provides added protection against motor damage and must be reset manually.

When the circuit breaker trips, turn the power off at the source before attempting any repairs. Inspect the pump thoroughly and clean or repair it as necessary.

### ⚠ CAUTION

Make sure the pump switch is in the off position before restoring power.

Reset the circuit breaker after repairs are complete. To reset, turn the pump's power switch off and then back on.

## MAINTENANCE

This pump is designed for minimum maintenance. Motor bearings are sealed and require no lubrication. Inspect the pump and components regularly for fuel leaks and make sure the hose and power cord are in good condition. Keep the pump exterior clean to help identify leaks.

Do not use this pump for water, chemicals, or herbicides. Dispensing any fluid other than those listed in this manual will damage the pump. Use of the pump with unauthorized fluids will void the warranty.

## To Clean or Replace Strainer

Turn the pump off and disconnect from power. Remove the strainer coverplate (Figure 3). Remove the inlet strainer and inspect for damage or clogs. Clean the strainer with a soft-bristled brush and solvent. If the strainer is very dirty, compressed air may be used. If damaged, replace the strainer.

FIGURE 3

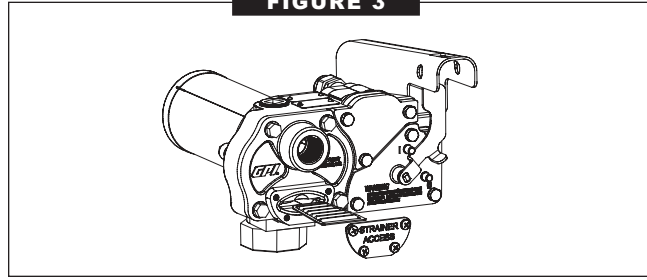

Place the strainer in the cavity. Clean the coverplate and O-ring. Coat the O-ring lightly with grease. Ensure the coverplate O-ring is properly seated and tighten the strainer coverplate.

## REPAIR

Carefully inspect all parts for wear or damage. Replace components, as necessary. The Illustrated Parts List gives information on replacement parts and kits.

Review the Safety Instructions before proceeding.

### ⚠ WARNING

Observe precautions against electrical shock when servicing the pump. Always disconnect power before repairing or servicing. Never apply electrical power to the system when any of the coverplates are removed.

### ⚠ WARNING

Avoid prolonged skin contact with petroleum fuels. Use protective goggles, gloves, and aprons in case of splashing or spills. Change saturated clothing and wash skin promptly with soap and water.

## Remove Pump from Tank

- Turn the pump off and disconnect from power.
- Turn the union ring counterclockwise to release the inlet fitting.
- Lift the pump and suction pipe from the bung adapter.
- Elevate the nozzle and hose to allow excess fuel to drain into the tank.
- Wipe the entire system with a clean cloth.

## Service O-Rings

A Wet Seal Kit contains all seals for your pump and should be on hand when performing repairs. Old seals may then be replaced with new ones as seals are accessible.

In general, when inspecting O-rings, look for breaks, wear, and signs of deterioration, such as swelling. Replace, as necessary. Before seating, coat O-rings with light grease.

## Replace Gears and Drive Key

- Turn the pump off and disconnect from power.
- Remove the gear coverplate. (Figure 4)

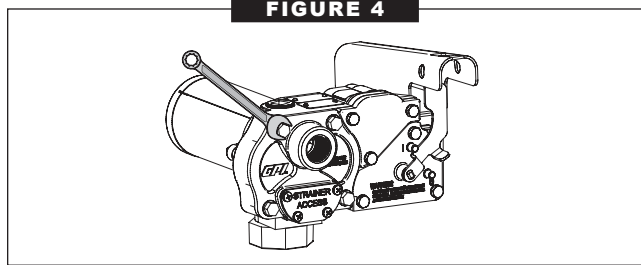

- Lift the drive key and gears from the pump. (Figure 5)

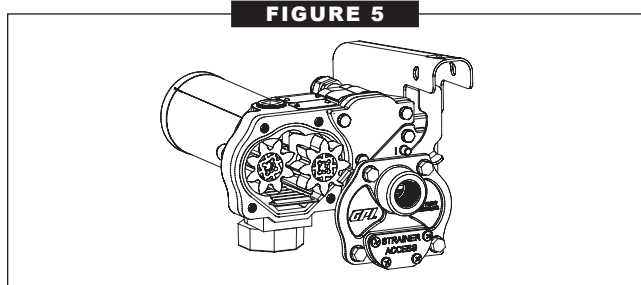

- Inspect the gears and key for wear and damage. Replace, as necessary.
- Wipe the gear cavity with a clean cloth.
- Replace the gears. Make sure they turn freely.
- Replace the drive key.
- Make sure the gear coverplate O-ring is securely in place. Tighten the coverplate to the housing.

## Clean or Replace Bypass Poppet

- Turn the pump off and disconnect from power.
- Using a drive ratchet or extension, remove the pipe plug from the top outlet port. (Figure 6)

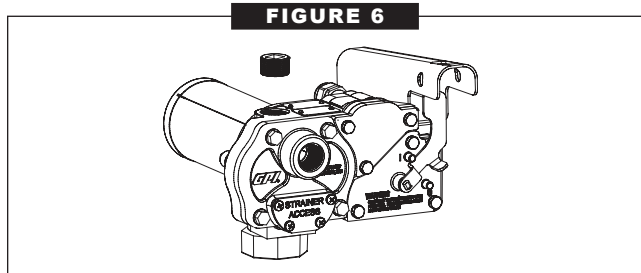

- Remove the gear coverplate and O-ring from the pump housing.
- Lift the drive key and two gears from the pump.
- To clean the bypass poppet:
  - With a clean cloth, wipe the poppet cavity through the top outlet port.

- Push down on the poppet until the poppet O-ring is exposed inside the housing. (Figure 7)

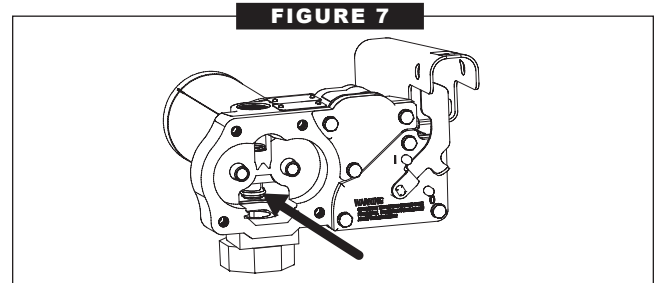

- Using a clean cloth, rotate the poppet and clean it thoroughly.
- To remove or replace the bypass poppet:
  - As above, push down on the poppet until the O-ring is exposed.
  - Remove the O-ring with a small screwdriver or similar tool. Take care not to damage the poppet or O-ring. (Figure 8)

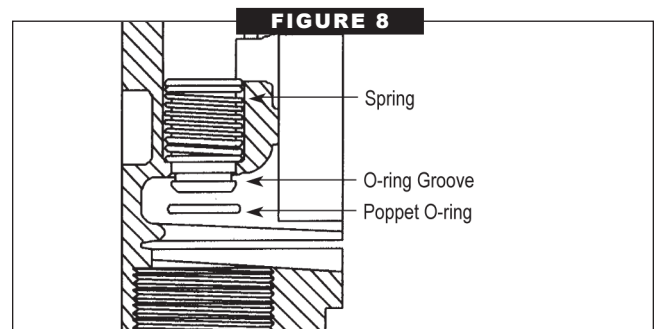

- From inside the housing, use a small screwdriver to push the poppet and spring through the top outlet port. (Figure 9)

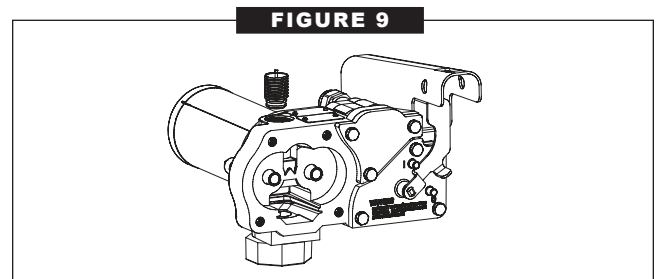

- Wipe the poppet and gear cavities with a clean cloth.
- Replace the poppet, O-ring, and spring, as necessary.

NOTE: Replace O-ring if damaged, swollen, or loose-fitting.

- To assemble, place the spring and poppet into the poppet cavity through the top outlet port. Compress the poppet into the housing. Coat the O-ring lightly with grease and slip over the poppet head. Make sure the O-ring is well seated.
- Push on the poppet through the top outlet port to make sure it moves freely.

- Install the pipe plug again.
- Replace the gears and drive key. Make sure gears turn freely with the key removed.
- Make sure the gear coverplate O-ring is in place. Tighten the coverplate to the pump housing.

## Service Motor Wiring

- Turn the pump off and disconnect from power.
- Remove the electrical coverplate from the pump housing. (Figure 10) Evaluate condition of gasket. Replace as needed.

**FIGURE 10**

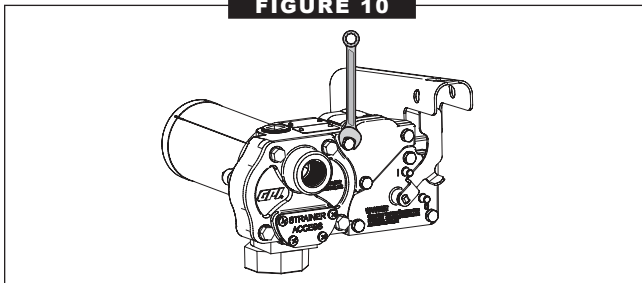

- Inspect the wiring connections and cavity. (Figure 11)

**FIGURE 11**

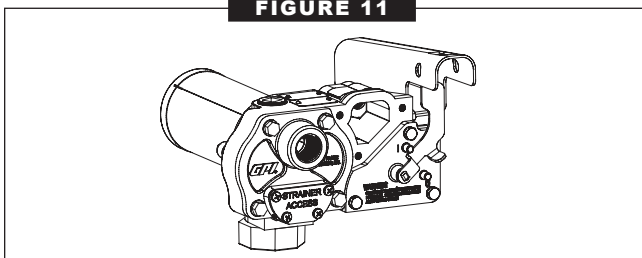

NOTE: If permanent wiring is damaged or corroded, the pump must be returned to the factory for wire replacement.

- Assemble again. Make sure the O-ring is in place and the coverplate is tightened securely.

## Replace Switch and Circuit Breaker

- Turn pump off and disconnect from power.
- Remove the switch coverplate from the pump housing. (Figure 12)

**FIGURE 12**

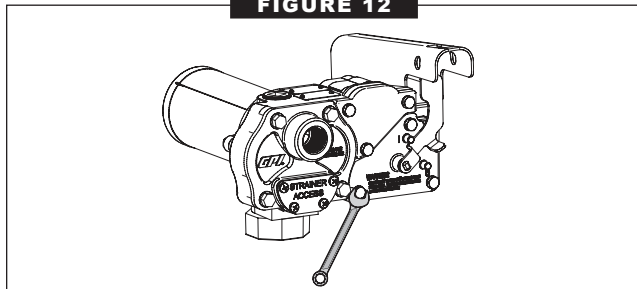

- Remove the torx head screw on the switch assembly, then remove the switch.
- Clip the black wires to the switch. Cut the wires close to the wire nut, leaving the maximum possible length to the pump.
- Loosen the hex nut on the switch mounting plate and remove the defective switch.
- Strip approximately 1/4 inch (0.6 cm) insulation from the black pump wires and connect to the replacement switch wires. There are no polarity requirements.
- Reinstall the new switch by reversing the above procedure. Guide the switch into the housing cavity, pushing black wires in before the switch. Use the housing slot to hold the switch into place.
- Switch mounting plate wires must clear the coverplate and must not be pinched. Make sure the O-Ring is properly seated before tightening the switch coverplate.

## Replace Switch Lever or Switch Lever Shaft O-Ring

- Turn off the pump and disconnect from power.
- Remove the switch coverplate from the pump housing.
- Remove the screw connecting the switch cam to the coverplate.
- Remove the cam and switch lever.
- Replace the switch lever or switch lever shaft O-Ring as needed.
- Reassemble by reversing above procedure. Make sure the O-ring is seated properly before tightening the coverplate.

## Replace Motor Shaft Seal

- Turn the pump off and disconnect from power.
- Remove the gear coverplate, gears, and drive key as described in Gear Replacement instructions.
- Remove the motor from the pump housing.
- Remove the motor shaft seal by prying out with a small screwdriver. (Figure 13)

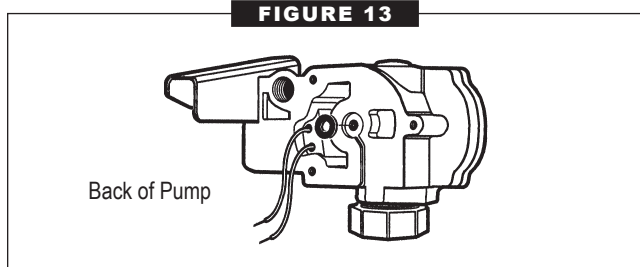

- Lubricate the gear shaft with WD-40® or a similar penetrating oil.
- Press a new motor shaft seal evenly in the pump housing until seated. Lubricate the seal with a lightweight motor oil.
- Gently slide the shaft through the seal until the motor is flush against the pump housing.
- Tighten the motor to the pump housing. Check for proper installation by working a .0015 feeler gauge around the motor flange. The gauge shall not fit between the flange and the housing.
- Install the gears and drive key as described in Gear Replacement instructions.

## Replace Motor

**NOTE: In order to preserve the UL Listing for pump safety, return the entire pump to the factory for motor repair or replacement.** For products serviced outside the factory, the UL nameplates must be defaced to indicate the equipment may no longer meet the requirements for UL Listing. This does not apply to products serviced outside the factory under the UL program for Rebuilt Motors for Use in Hazardous Locations.

## TROUBLESHOOTING

SYMPTOM	PROBABLE CAUSE	CORRECTIVE ACTION
A. MOTOR DOES NOT RUN	<ol style="list-style-type: none"> <li>1. Auxiliary temperature-limiting device tripped</li> <li>2. Switch's circuit breaker tripped</li> <li>3. Switch defective</li> <li>4. Motor burned out</li> </ol>	<p>Turn pump switch off. Allow motor to cool approximately 30 minutes. Device resets automatically. Try again.</p> <p>Turn power off at source. Determine source of high amp draw. Correct problem. Make sure pump switch is in off position before restoring power. Restore power to pump. Circuit breaker is reset manually by turning pump's power switch off and on</p> <p>Remove switch coverplate and inspect switch. Replace, if necessary.</p> <p>Replace motor as described in the Repair Section.</p>
B. MOTOR RUNS BUT DOES NOT PUMP FLUID	<ol style="list-style-type: none"> <li>1. Drive key broken</li> <li>2. Suction pipe clogged, damaged, or missing</li> <li>3. Gear coverplate or O-ring damaged</li> <li>4. Strainer clogged or defective</li> <li>5. Bypass poppet O-ring worn or missing</li> <li>6. Bypass poppet O-ring dirty</li> <li>7. System air leak</li> <li>8. System air lock</li> <li>9. Poor connections or low voltage</li> <li>10. Fuel level low</li> <li>11. Bypass poppet binding or damaged</li> </ol>	<p>Remove gear coverplate and replace drive key. Make sure gears turn freely with the key removed.</p> <p>Remove pump from tank. Inspect suction pipe. Clean or replace, as necessary.</p> <p>Remove and inspect the coverplate and O-ring. Replace, as necessary. Refer to the Repair Section on Servicing O-rings.</p> <p>Remove strainer coverplate. Remove and clean strainer. Install again.</p> <p>Inspect the O-ring, using instructions in the Repair Section. Replace, if necessary.</p> <p>Remove poppet assembly and clean poppet and cavity.</p> <p>Tighten all pump fittings and connections. Inspect suction pipe for leaks or damage.</p> <p>This can occur if external filter, meters, or an off-the-shelf automatic nozzle is being used. To correct, remove the pipe plug in the top outlet port and fill the gear cavity with fuel. Use of a factory-supplied automatic nozzle is recommended.</p> <p>Make sure electrical connections are secure. Check power source.</p> <p>Fill tank.</p> <p>Remove the bypass poppet, spring, and O-ring. Clean cavity. Inspect and replace components, as necessary.</p>
C. LOW FLOWRATE	<ol style="list-style-type: none"> <li>1. Poor connections or low voltage</li> <li>2. Strainer partially clogged</li> <li>3. Suction pipe clogged or damaged</li> <li>4. Fuel tank empty</li> <li>5. Using off-the-shelf automatic nozzle</li> <li>6. System air leak</li> <li>7. Suction pipe too close to tank bottom</li> <li>8. Bypass poppet spring weak</li> <li>9. Discharge hose too long</li> </ol>	<p>Make sure electrical connections are secure. Also check power source.</p> <p>Remove the strainer coverplate. Remove and clean the strainer. Install again.</p> <p>Remove pump from tank. Inspect suction pipe. Clean or replace, as necessary.</p> <p>Fill tank.</p> <p>Factory-supplied automatic nozzle is recommended.</p> <p>Tighten all pump fittings and connections. Inspect suction pipe for leaks or damage. Replace, as necessary.</p> <p>Suction pipe must have at least 1/4 in. (0.6 cm) clearance from bottom of the tank.</p> <p>Remove the bypass poppet and inspect spring. Replace, if necessary.</p> <p>Long hoses reduce flow rate. Shorten hose.</p>
D. MOTOR STALLS WHEN OPERATING IN BYPASS MODE	<ol style="list-style-type: none"> <li>1. Running too long in bypass mode</li> <li>2. Gears worn</li> <li>3. Wiring defective</li> <li>4. Bypass poppet binding or damaged</li> <li>5. Motor defective</li> </ol>	<p>Limit bypass operation to 10 minutes.</p> <p>Remove gear coverplate and inspect gears and drive key. Make sure gears turn freely with the key removed. Replace, if worn.</p> <p>Use Wiring instructions in the Installation Section to ensure proper connections.</p> <p>Remove the bypass poppet, spring, and O-ring. Clean cavity. Inspect components and replace, as necessary.</p> <p>Replace motor as described in the Repair Section</p>
E. RAPID OVERHEAT OF MOTOR	<ol style="list-style-type: none"> <li>1. Duty cycle too long</li> <li>2. Strainer clogged</li> <li>3. Suction pipe clogged or damaged</li> <li>4. Gears worn</li> <li>5. Fuel level low</li> <li>6. Running too long in bypass mode</li> </ol>	<p>Pump operation should not exceed the standard duty cycle of 30 minutes ON, and 30 minutes OFF. Allow the pump to cool for 30 minutes.</p> <p>Remove strainer coverplate. Remove and clean strainer. Install again.</p> <p>Remove pump from tank. Inspect suction pipe. Clean or replace, as necessary.</p> <p>Remove gear coverplate and inspect gears and drive key. Make sure gears turn freely with key removed. Replace, if necessary.</p> <p>Fill tank.</p> <p>Limit bypass operation to 10 minutes</p>



# ILLUSTRATED PARTS DRAWING

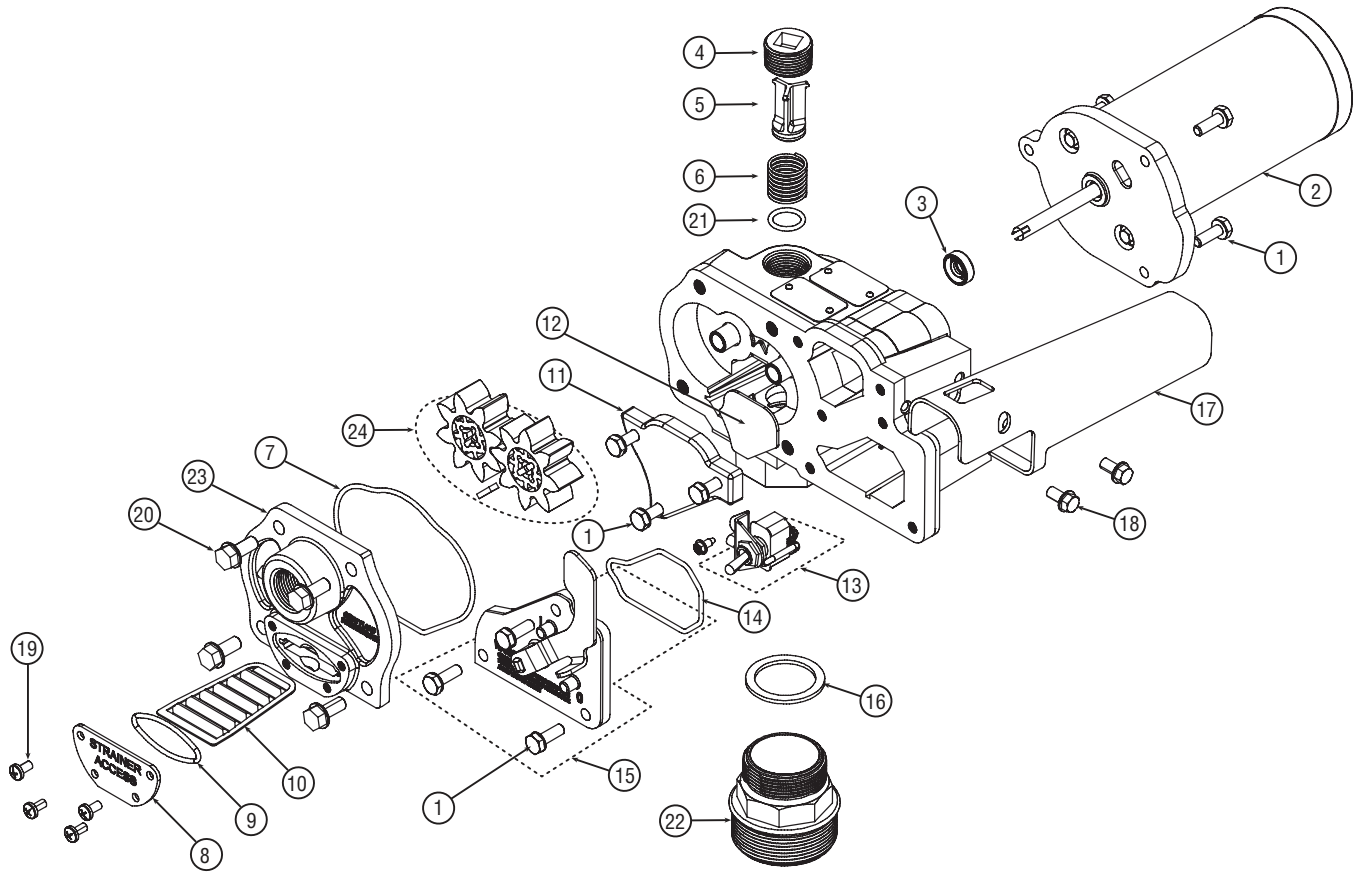

Item No.	Part No.	Description	No. Req'd.
1	904002-23	Sems Screw, 1/4-20 x 3/4 in. ....	9
2	119008-551	Motor, 120-volt AC with Circuit Board .....	1
3	110025-1	Motor Shaft Seal.....	1
4	90400770	Pipe Plug, 3/4 inch .....	1
5	110010-1	Bypass Poppet.....	1
6	110131-2	Bypass Poppet Spring .....	1
7	901003-70	Gear Coverplate O-Ring.....	1
8	11040201	Coverplate, Strainer, ENP.....	1
9	110026-4	Strainer Coverplate O-Ring .....	1
10	110009-1	Inlet Strainer .....	1
11	110195-02	Electrical Coverplate .....	1
12	110285-01	Electrical Cover Gasket .....	1
13	119096-4	Switch and Circuit Breaker Assembly .....	1
14	110026-6	Switch Coverplate O-Ring.....	1
15	110276-02	Switch Coverplate Assembly .....	1
16	110032-1	Union Ring Gasket .....	1
17	11030302	Cover, Nozzle .....	1
18	904006-86	Screw, Tapping.....	2
19	904002-22	Sems Screw .....	4
20	904002-24	Sems Screw .....	4
21	90100399	O-Ring, NBR.....	1
22	110037-1	Bung Adapter Tank Bushing.....	1
23	11040301	Gear Coverplate, ENP .....	1
24	110907-1	Gear Kit - Includes 2 Gears & Drive Key .....	1

### Items not shown

11040001	Inlet Fitting, ENP
110158-1	Union Ring
110913-2	Spare Key Kit
110909-1	Bung Adapter Kit
906001-4	Pressure Vent Cap (3 PSI)

## SPECIFICATIONS

### Application:

This pump is specifically designed for use with methanol and ethanol. The pump is also compatible with gasoline, diesel fuel (up to 20% biodiesel blends such as B20) and kerosene. Pump is designed for permanent mounting on vented storage tanks. *RAINPROOF* for outdoor use.

### Pump Housing:

Lightweight, corrosion-resistant, nickel plated, cast aluminum body, convenient union ring for easy installation.

### Performance:

Pump Rate: Up to 12 GPM (45 LPM)  
Duty Cycle: 30 min. ON, 30 min. OFF  
Suction Lift:  
Manual Nozzle: Up to 5.5 ft. (1.7 m)  
Automatic Nozzle: Up to 4.8 ft. (1.5 m)

### Operating Temperature:

-20°F to +125°F (-29°C to +52°C)

### Operating Pressure:

15 PSI

### Electrical Specifications:

Input: 120 volt AC  
Motor: 1400 RPM, 1/8 HP (93 Watts)  
Motor Approval: UL Listed

### Motor Protection:

2.5 amp circuit breaker and auxiliary temperature limiting device.

### Mechanical Connections:

Bung: 2 in. NPT  
Inlet: 1 in. NPT  
Outlet: 3/4 in. NPT

### Weight:

Shipping: 15 lbs. (6.8kg)

## PARTS AND SERVICE

In order to preserve the UL Listing for the motor, do not attempt to service the motor. For products serviced outside the factory, the UL nameplate must be defaced to indicate that the equipment may no longer meet the requirements for UL Listing. This does not apply to products serviced outside the factory under the UL program for Rebuilt Motors for Use in Hazardous Locations.

For warranty consideration, parts, or other service information, please contact your local distributor. If you need further assistance, contact the GPI Customer Service Department in Wichita, Kansas, during normal business hours.

A toll free number is provided for your convenience.

**1-800-835-0113**

To obtain prompt, efficient service, always be prepared with the following information:

1. The model number of your pump.
2. The serial number or manufacturing date code of your pump.
3. Part descriptions and numbers.

Part information can be obtained from the Illustrated Parts List.

For warranty work, always be prepared with your original sales slip or other evidence of purchase date.

Please contact GPI before returning any parts. It may be possible to diagnose the trouble and identify needed parts in a telephone call. GPI can also inform you of any special requirements you will need to follow for shipping fuel dispensing equipment.

### **⚠ CAUTION**

**Do not return the pump or parts without authority from the Customer Service Department. Due to strict government regulations, GPI cannot accept parts unless they have been drained and cleaned.**

**SAVE THESE INSTRUCTIONS**



## Limited Warranty Policy

Great Plains Industries, Inc. 5252 E. 36<sup>th</sup> Street North, Wichita, KS USA 67220-3205, hereby provides a limited warranty against defects in material and workmanship on all products manufactured by Great Plains Industries, Inc. This product includes a 2 year warranty from date of purchase as evidenced by the original sales receipt. A 30 month warranty from product date of manufacture will apply in cases where the original sales receipt is not available. Reference product labeling for the warranty expiration date based on 30 months from date of manufacture. Manufacturer's sole obligation under the foregoing warranties will be limited to either, at Manufacturer's option, replacing or repairing defective Goods (subject to limitations hereinafter provided) or refunding the purchase price for such Goods theretofore paid by the Buyer, and Buyer's exclusive remedy for breach of any such warranties will be enforcement of such obligations of Manufacturer. The warranty shall extend to the purchaser of this product and to any person to whom such product is transferred during the warranty period.

This warranty shall not apply if:

- A. the product has been altered or modified outside the warrantor's duly appointed representative;
- B. the product has been subjected to neglect, misuse, abuse or damage or has been installed or operated other than in accordance with the manufacturer's operating instructions.

To make a claim against this warranty, contact the GPI Customer Service Department at 316-686-7361 or 800-835-0113. Or by mail at:

Great Plains Industries, Inc.  
5252 E. 36<sup>th</sup> St. North  
Wichita, KS, USA 67220-3205

GPI will step you through a product troubleshooting process to determine appropriate corrective actions.

GREAT PLAINS INDUSTRIES, INC., EXCLUDES LIABILITY UNDER THIS WARRANTY FOR DIRECT, INDIRECT, INCIDENTAL AND CONSEQUENTIAL DAMAGES INCURRED IN THE USE OR LOSS OF USE OF THE PRODUCT WARRANTED HEREUNDER.

The company herewith expressly disclaims any warranty of merchantability or fitness for any particular purpose other than for which it was designed.

This warranty gives you specific rights and you may also have other rights which vary from U.S. state to U.S. state.

Note: In compliance with MAGNUSON MOSS CONSUMER WARRANTY ACT – Part 702 (governs the resale availability of the warranty terms).



800-835-0113 / GPI.net



©2013, Great Plains Industries, Inc. All rights reserved. Made in U.S.A. The electric gear pump,  and The Proven Choice™ are trademarks and GPI is a registered trademark of Great Plains Industries, Inc. Printed in U.S.A.