



SERVICE CAMPAIGN BULLETIN

SUBJECT:			No: SC-15-003REV
POTENTIAL TRANSMISSION SHUDDER/SURGE – SERVICE CAMPAIGN – REVISED			DATE: October, 2016
			MODEL: 2015 Outlander Sport/ RVR
CIRCULATE TO:	<input checked="" type="checkbox"/> GENERAL MANAGER	<input checked="" type="checkbox"/> PARTS MANAGER	<input checked="" type="checkbox"/> TECHNICIAN
<input checked="" type="checkbox"/> SERVICE ADVISOR	<input checked="" type="checkbox"/> SERVICE MANAGER	<input checked="" type="checkbox"/> WARRANTY PROCESSOR	<input checked="" type="checkbox"/> SALES MANAGER

This bulletin supersedes SC-15-003, issued November 2015, to provide clarification regarding vehicles covered by both SC-15-003 and SR-16-006 “CVT Hesitation – Safety Recall Campaign.” Revisions are italicized and indicated by ◀.

PURPOSE

Certain vehicles with CVT-8 transmissions may exhibit a shudder condition at low speeds (10 – 40 mph), or a surge/flare of engine rpm at higher speeds. This may be caused by a malfunctioning of the CVT's hydraulic pressure control software. In the worst case scenario, with continued driving under these conditions, the CVT belt may become damaged, causing a warning light to turn on.

- ▶ This campaign bulletin instructs dealers to *refer to SR-16-006* to reprogram the *CVT-ECU* on all affected vehicles. In the rare case that the customer informs the dealer they have experienced a shudder or surge condition, dealers are instructed to reprogram the *CVT-ECU*, then *follow the procedure for shudder/surge condition as outlined in this bulletin.*

AFFECTED VEHICLES

Certain 2015 Outlander Sport/RVR vehicles with 2.0L engine and CVT-8 transmission built from June 25, 2014 to September 14, 2015.

- ▶ **!! IMPORTANT !!** *If the CVT-ECU was previously reprogrammed as part of SR-16-006 “CVT Hesitation – Safety Recall Campaign” and the customer did not inform the dealer that they had experienced a shudder or surge condition, this Service Campaign does not apply. The CVT-ECU reprogramming for SR-16-006 includes all the necessary programming fixes for this Service Campaign.*
- ▶ **!! IMPORTANT !!** *If a vehicle has SC-15-003 and SR-16-006 open, and the customer does not inform the dealer that they had experienced a shudder or surge condition, complete SR-16-006 only.*
- ▶ **!! IMPORTANT !!** *If a vehicle has SC-15-003 and SR-16-006 open, and in the rare case that the customer informs the dealer that they had experienced a shudder or surge condition, complete SR-16-006 and follow SC-15-003's procedure for shudder/surge condition.*

IMPORTANT

To maximize customer satisfaction with the quality of their vehicle, affected new or used inventory vehicles should be remedied before the vehicle is delivered. Dealers must check their inventory vehicles' VINs on the Warranty Superscreen to verify whether the vehicle is involved in this service campaign.

CUSTOMER NOTIFICATIONS

- ▶ A letter will be sent to all owners of affected vehicles *that have not had SC-15-003 and SR-16-006 completed*, requesting they schedule an appointment with their local Mitsubishi dealer to have their vehicle remedied. A copy of the customer notification letter appears at the end of this bulletin.

REQUIRED OPERATIONS

Before starting this campaign procedure, **CHECK THE WARRANTY SUPERSCREEN** to verify if the vehicle is an affected VIN for this campaign and this campaign procedure has not already been completed.

REQUIRED EQUIPMENT

The following equipment is needed to read and erase DTCs from all ECUs:

- VCI (Vehicle Communication Interface) or VCI Lite – MB991824 or MB992744V.
- MEDIC Laptop/Tablet with A/C power adapter – 520924, or FZG1MK2.
- MUT-III main harness 'A' (blue connector at the DLC end) – MB991910 or MB992745V.
- USB 2.0 cable – MB991827 or RRAR1MBR-108L.

SERVICE CAMPAIGN FLOW CHART

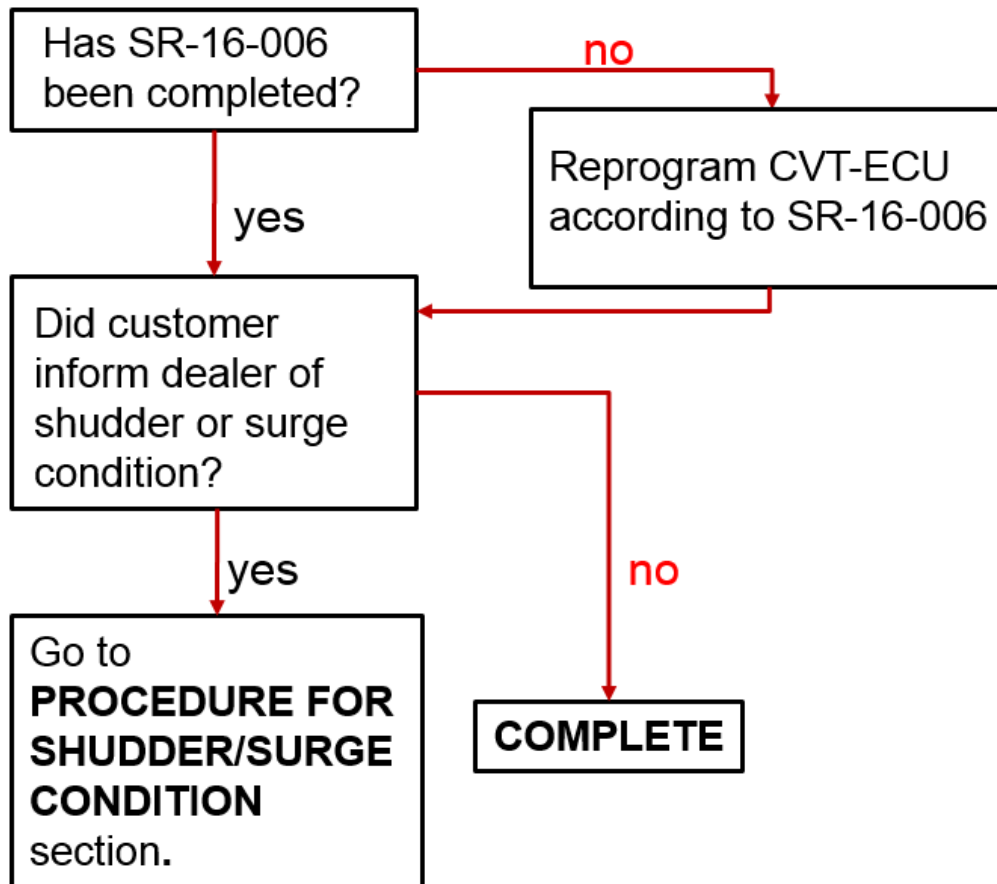

PROCEDURE FOR SHUDDER/SURGE CONDITION (Only if Reported by Customer)

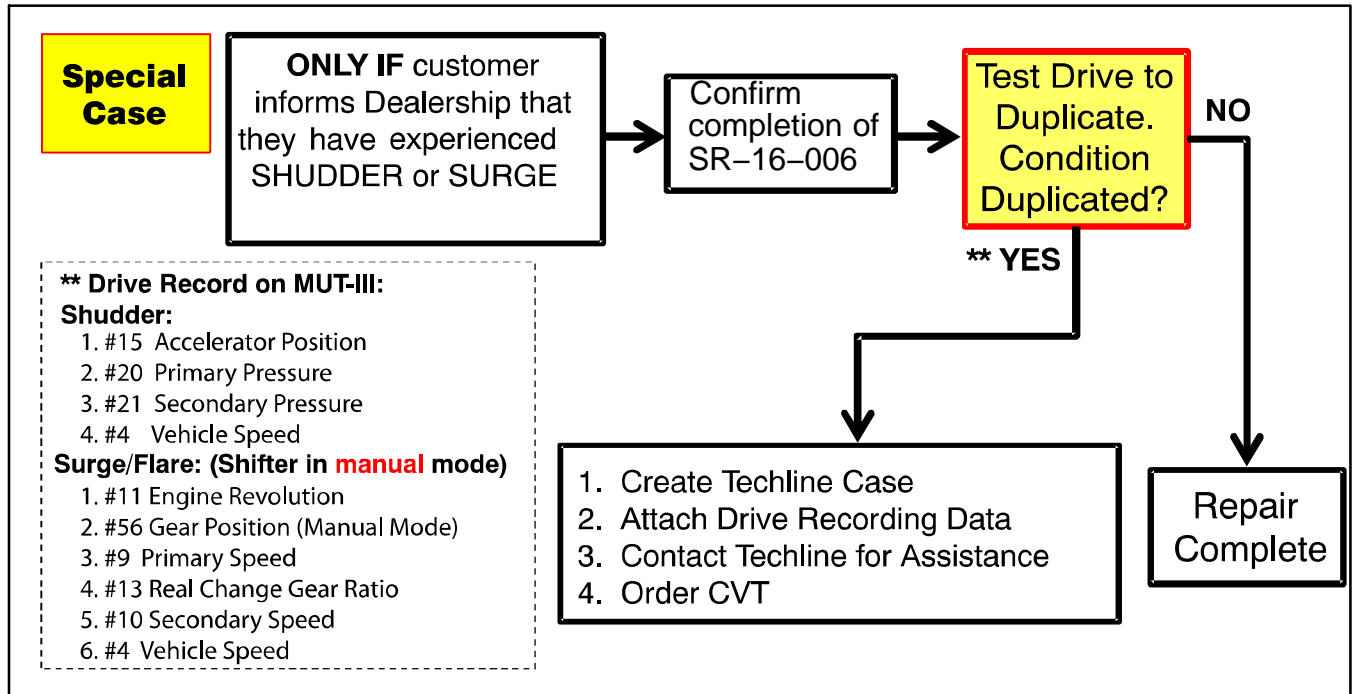

Follow this procedure ONLY if customer has reported experiencing a shudder or surge condition.

1. Verify that the vehicle has been reprogrammed according to SR-16-006.
2. Test drive the vehicle to see if the shudder/surge condition can be duplicated.

Refer to **FIGURE 1** and **FIGURE 2**: Setup MUT-III with the applicable Drive Record parameters, then follow the Test Drive procedures to duplicate these conditions.

For instructions on setting up Drive Recordings, go to:
MDL > service > systems > Techline > Techline Videos.
Under "Service Videos" scroll down to "MUT III" and select "MUT III Drive Recorder Setup."



Test drive route should be relatively free from other traffic so you can safely conduct the test and concentrate on vehicle operation and performance. ALWAYS follow all traffic laws and safe driving practices.

FIGURE 1. Test Drive Procedure for Duplicating CVT-8 Shudder

Drive Record Items:
 #15: Accelerator Position
 #20: Primary Pressure
 #21: Secondary Pressure
 #4: Vehicle Speed

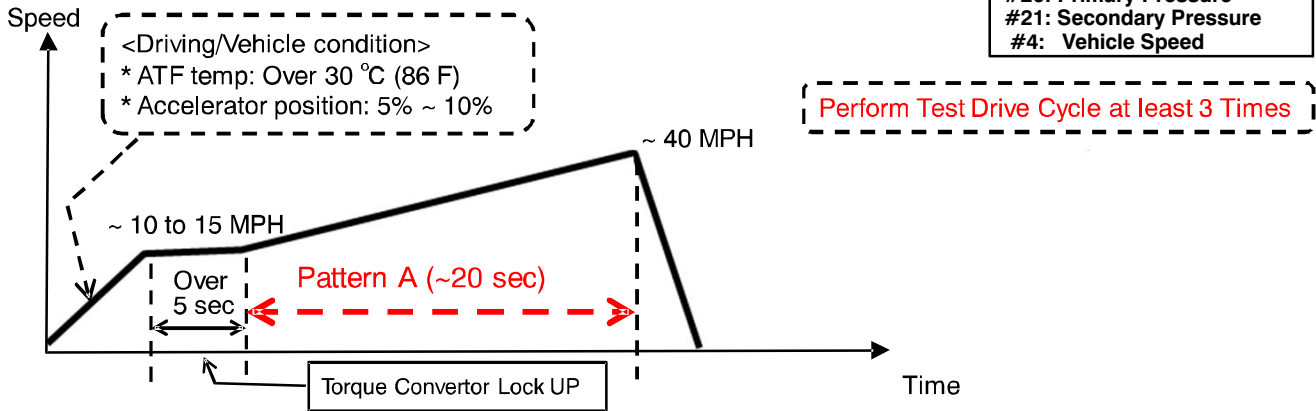

	Condition	Driving Criteria	Judgment Criteria
Pattern A (Slow acceleration)	Shudder	<ul style="list-style-type: none"> Slow & gentle acceleration 10 to 40 MPH Constant acceleration Approximately 10% throttle angle Slight uphill grade or flat road 	<ul style="list-style-type: none"> Vehicle shuddering is felt Can be described also as a "bucking" Can also be described as a "judder" or repeated "jerking"

FIGURE 2. Test Drive Procedure for Duplicating CVT-8 Surge/Flare

Drive Record Items:
 #11: Engine Revolution
 #56: Gear Position (Manual Mode)
 #9: Primary Speed
 #13: Real Change Gear Ratio
 #10: Secondary Speed
 #4: Vehicle Speed

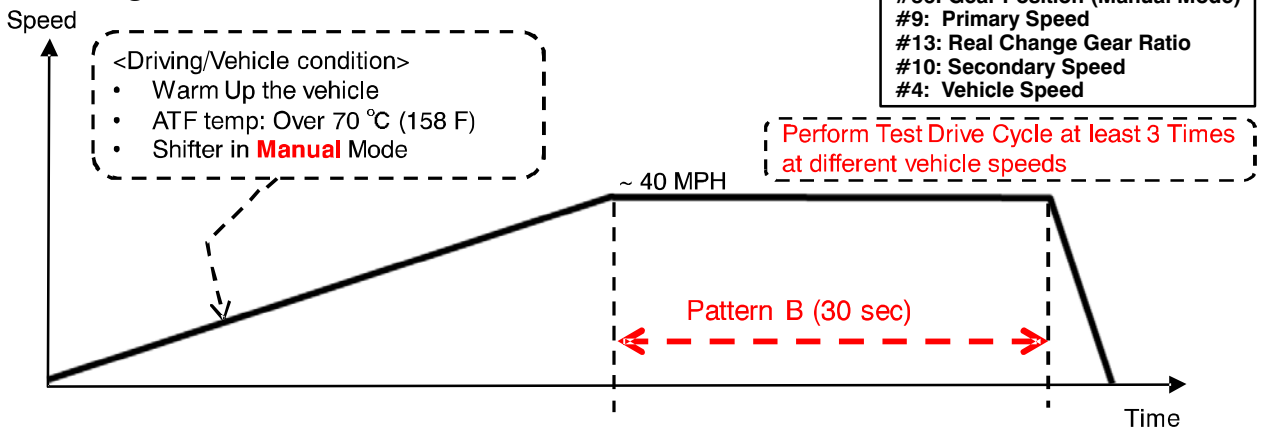

	Condition	Driving Criteria	Judgment Criteria
Pattern B (Constant Vehicle Speed)	Surge/Flare	<ul style="list-style-type: none"> Steady speed highway driving (follow all applicable laws) <ul style="list-style-type: none"> ~ 40 MPH ~ 50 MPH ~ 65 MPH ATF Temp > 158 F (warmed up) Shifter in Manual Mode 	<ul style="list-style-type: none"> Engine RPM surging or flaring (more than 200 RPM from base) at steady state vehicle condition

3. Was the shudder/surge condition duplicated?
 - **YES** – Go to step 4.
 - **NO** – Repair is complete. Return vehicle to customer.
4. Create a Techline case.
5. Attach the following Drive Recording Data from MUT-III to the Techline case.

Shudder

<u>No.</u>	<u>Description</u>
15	Accelerator Position
20	Primary Pressure
21	Secondary Pressure
4	Vehicle Speed

Surge/Flare

<u>No.</u>	<u>Description</u>
11	Engine Revolution
56	Gear Position (Manual Mode)
9	Primary Speed
13	Real Change Gear Ratio
10	Secondary Speed
4	Vehicle Speed

6. Contact Techline for assistance.
7. Order the applicable new CVT-8 transmission assembly.
8. Replace the CVT-8 transaxle, flush the external cooler, and perform the CVT ECU coding procedures found in TSB-15-23-001.

PARTS INFORMATION

Use the genuine Mitsubishi Parts listed below:

NOTE: ONLY order a new CVT-8 transmission after completing the “**Procedure for Shudder/Surge Condition**” in this Service Campaign.

Description	Part Number	Quantity
CVT-8 Transmission Assembly (2WD)	2700A401	1
CVT-8 Transmission Assembly (AWD)	2700A403	1
Transmission Fluid: Mitsubishi Motors Genuine CVTF-J4	MZ320185	6.9 L (7.3 qt)

WARRANTY INFORMATION

CVT-ECU reprogramming must be claimed per SR-16-006 only. If the CVT-ECU was previously reprogrammed as part of SR-16-006 "CVT Hesitation – Safety Recall Campaign" and the customer did not inform the dealer that they had experienced a shudder or surge condition, this Service Campaign does not apply.

There are only 2 possible repair scenarios for this Service Campaign. You may only claim 1.

#	Repair Procedures	Campaign Operation	Labor Time Allowance
1	Verify that SR-16-006 has been performed and perform a test drive per the TSB--which indicates the CVT transmission assembly requires replacement.	Refer to TSB C1512Z03	6.5 hrs If the vehicle is a <u>2WD Model</u>
2	Verify that SR-16-006 has been performed and perform a test drive per the TSB--which indicates the CVT transmission assembly requires replacement.	Refer to TSB C1512Z04	7.6 hrs If the vehicle is a <u>AWD Model</u>

Warranty/Recall Campaign Claim Information

Enter all claims as claim type "C" – Recall/Campaign Claims.

Please follow the campaign instructions when entering each claim in order to select the applicable operation codes that correctly match up with the work that was actually performed. A claim example is provided below.

Certain 2015MY with 2.0L & CVT-8 Automatic Trans – Outlander Sport/RVR models.

There are 2 Possible Operations	Labor Operation	Labor Time
1. 2WD '15 MY Outlander Sport/RVR – Verify SR-16-006 Completion, Test Drive & Replace CVT	C1512Z03	6.5 hrs
2. AWD '15 MY Outlander Sport/RVR – Verify SR-16-006 Completion, Test Drive & Replace CVT	C1512Z04	7.6 hrs

Claim Header Section:

After entering the required customer data, vehicle data, and campaign operation number, hitting the **“Save and Continue”** button, the system will automatically fill-in several fields. **Please note there are 2 possible repair scenarios for this campaign.**

CAMPAIGN INFORMATION			
Campaign Operation No	C1512Z	2015 MY Outlander Sport/RVR 2.0L A/T Only	Repair Performed
Miles / KM	14,500		Repair Order No
VIN	4A4AP3AUXFE000077	Repair Date In	Repair Date Out
		12 / 30 / 2015	12 / 30 / 2015
			C1512Z03 Verify that SR-16-006 has been performed and perform a test drive per the TSB--which indicates the CVT transmission assembly requires replacement. Only for 2WD models. C1512Z04 Verify that SR-16-006 has been performed and perform a test drive per the TSB--which indicates the CVT transmission assembly requires replacement. Only for AWD models.

Service Campaign Claim Example:

Follow these instructions for this campaign.

Parts:

▶ No parts are needed for the *SR-16-006 CVT-ECU reprogramming*. If the CVT requires replacement, follow the instructions in the TSB.

Labor:

▶ The full service campaign labor operation number is one of the 2 numbers shown and the allowed labor times vary. One will be automatically entered as a result of the 'Repair Performed' scenario you first selected from the "Vehicle" page.

Campaign Number: C1512Z			
Campaign Operations - Select from Claim Drop Down Menu			Labor Times
Select the repair actually performed and the corresponding operation scenario and time shown below. Check the repair order to be sure you are selecting the correct repair.			
	Repair Descriptions	Operation Scenarios	USA & PUERTO RICO OUTLANDER SPORT
#1	Verify that SR-16-006 has been performed and perform a test drive per the TSB--which indicates the CVT transmission assembly requires replacement. Only for 2WD models.	C1512Z03	6.5 hrs
#2	Verify that SR-16-006 has been performed and perform a test drive per the TSB--which indicates the CVT transmission assembly requires replacement. Only for AWD models.	C1512Z04	7.6 hrs

Other Charges:

In rare cases, towing and/or a rental car may be necessary. The lower portion of the labor page has the fields that must be filled in if there are such charges.

Special Sublet Selection				
Select	Labor Operation	Labor Operation Description		Amount
<input type="checkbox"/>	SHO	SPECIAL HANDLING ORDER	SHO Parts Order	
<input type="checkbox"/>	RENTACAR	RENTAL CAR CHARGES	Days <input type="text"/> Reason <Select one> <input type="text"/>	
<input type="checkbox"/>	95300040	FREIGHT CHARGES	Rental Company <input type="text"/> Invoice Number <input type="text"/>	
<input type="checkbox"/>	95200040	TOWING CHARGES	Freight Company <input type="text"/> Invoice Number <input type="text"/>	
			Towing Company <input type="text"/> Invoice Number <input type="text"/>	



Mitsubishi Motors North America, Inc.
6400 Katella Avenue
Cypress, CA 90630
Telephone: 714-372-6000
www.mitsubishi.com

AFFECTED VEHICLES
MODEL: 2015 Outlander Sport/RVR

This notice applies to your vehicle, _____.

Date: October, 2016

Re: Customer Satisfaction Campaign SC-15-003

Dear FIRSTNAME LASTNAME,

Mitsubishi Motors strives to build vehicles with the highest level of quality, and continuously improve that quality with every vehicle built. To help assure continued satisfaction with your Mitsubishi vehicle, we are urging that the following product improvement be performed, as soon as possible. Failure to have this campaign timely completed may result in damage to your vehicle's transmission.

Our records indicate that you have not yet responded to previous notification letters for Customer Satisfaction Campaign SC-15-003 and Safety Recall Campaign SR-16-006. Please do so immediately.

Recommended Product Improvement:

Certain vehicles with CVT-8 transmissions may exhibit a shudder condition at low speeds (10 – 40 mph), or a surge/flare of engine rpm at higher speeds. This may be caused by a malfunctioning of the CVT's hydraulic pressure control software. In the worst case scenario, with continued driving under these conditions, the CVT belt may become damaged, causing a warning light to come on. Continued operation under these conditions can eventually cause damage to your vehicle's transmission. A CVT-ECU update is available to address this potential software malfunction.

What your dealer will do:

Your local Mitsubishi dealer will reprogram the CVT-ECU; this repair will take from 0.3 to 0.6 hours to complete. In extreme cases, the transmission may need to be replaced; this repair will take approximately 6.8 to 8.2 hours. However, the dealer may need your vehicle for a longer period of time. Every effort will be made to minimize your inconvenience.

What you should do:

Please contact your local Mitsubishi dealership to schedule an appointment to complete Customer Satisfaction Campaign SC-15-003 and Safety Recall Campaign SR-16-006. The CVT-ECU reprogramming that your Mitsubishi dealership will perform satisfies the requisites of both Customer Service Campaign SC-15-003 and Safety Recall Campaign SR-16-006. Although not required, it is recommended to bring this letter when you take your vehicle into the dealership.

If you have any questions regarding this customer satisfaction campaign, please contact us:

Mitsubishi Customer Relations Department
P.O. Box 6400
Cypress, CA 90630-0064
Phone 1-888-648-7820
Hours: Monday – Friday 7 a.m. – 4 p.m. Pacific Time

If you have already encountered a problem with the CVT-8 transmission and had it reprogrammed or replaced as a result of this specific condition and have paid for the repair, you may send your original repair order or invoice, and original receipt/proof of payment to the following address for reimbursement consideration:

Mitsubishi Customer Relations Department, P.O. Box 6400, Cypress, CA 90630-0064

We appreciate your prompt attention to this matter, and apologize for any inconvenience.

Sincerely,

Mitsubishi Motors North America, Inc.

C1512Z