

**AXMINSTER**

**Engineer**  
**SERIES**



Code **505111**

Code **505189**

# **SC4/410 & SC4/510**

## **Metal Bench Lathes**

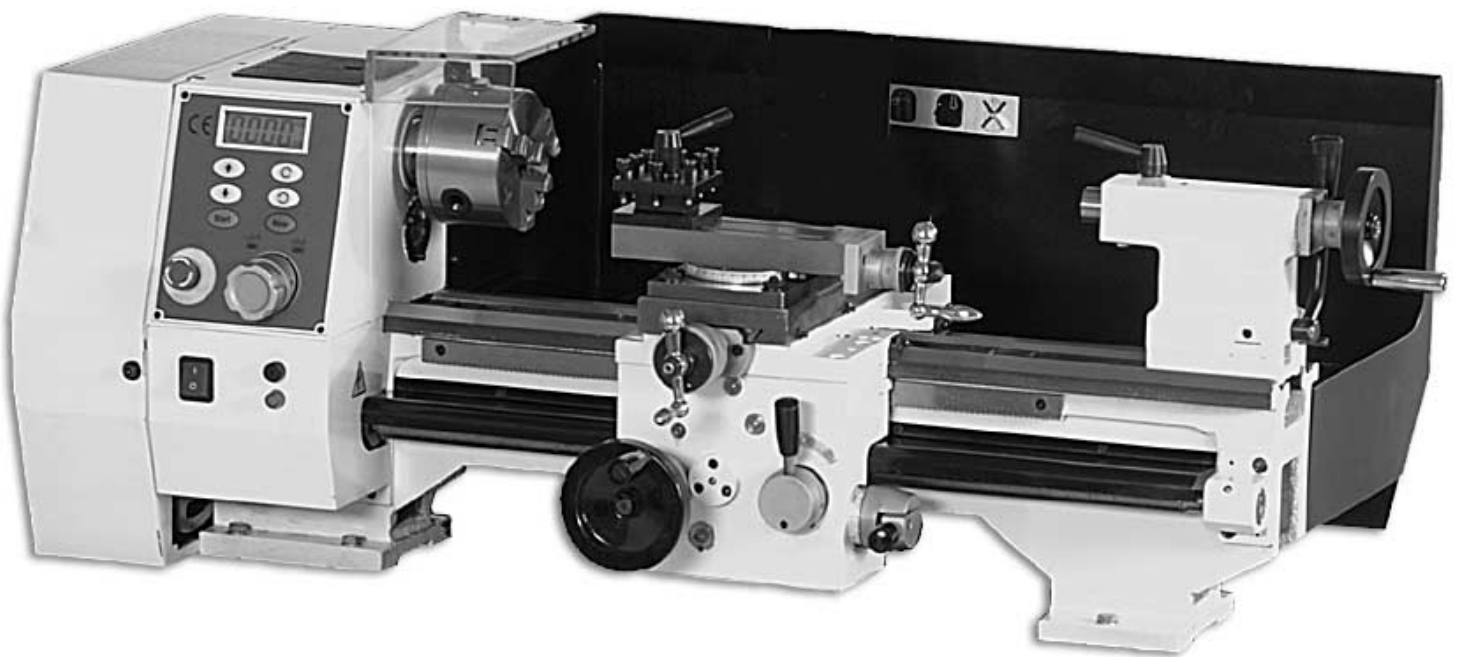

## **IMPORTANT SAFETY INSTRUCTIONS**

***READ ALL INSTRUCTIONS AND WARNINGS BEFORE USING THIS TOOL.***

### **Operator**

COMMON SENSE AND CAUTION ARE FACTORS WHICH CANNOT BE BUILT INTO ANY PRODUCT. THESE FACTORS MUST BE SUPPLIED BY THE OPERATOR. PLEASE REMEMBER:

1. When using electric tools, machines or equipment, basic safety precautions should always be followed to reduce the risk of fire, electric shock, and personal injury.
2. Keep work area clean. Cluttered areas invite injuries.'
3. Consider work area conditions. Do not use machines or power tools in damp, wet or poorly lit locations. Do not expose equipment to rain. Keep work area well lit. Do not use tools in the presence of flammable gases or liquids.
4. Keep children away. All children should be kept away from the work area.
5. Guard against electric shock. Prevent body contact with grounded surfaces such as pipes, radiators, ranges, and refrigerator enclosures.
6. Stay alert. Never operate equipment if you are tired.
7. Do not operate the product if under the influence of alcohol or drugs. Read warning labels on prescriptions to determine if your judgment or reflexes might be impaired.
8. Do not wear loose clothing or jewelry as they can be caught in moving parts.
9. Wear restrictive hair covering to contain long hair.
10. Use eye and ear protection. Always wear.
  - ANSI approved chemical splash goggles when working with chemicals.
  - ANSI approved impact safety goggles at other times.
  - ANSI approved dust mask or respirator when working around metal, wood, and chemical dusts and mists.
  - A full face shield if you are producing metal or wood filings and/or chips.
11. Keep proper footing and balance at all times.
12. Do not reach over or across running machinery.
13. Always check that adjusting keys and wrenches are removed from the tool or machine before starting it.
14. Do not carry any tool with your finger on the start button or trigger.
15. When servicing. Use only identical replacement parts.

### **Before Operation**

1. Be sure the switch is OFF when not in use and before plugging in to wall outlet.
2. Do not use inappropriate attachments in an attempt to exceed the tool's capacity. Approved accessories are available from the dealer or machine maker.
3. Check for damaged parts. Before using any tool, any part that appears damaged should be carefully checked to determine that it will operate properly and perform its intended function.
4. Check for alignment and binding of all moving parts. Broken parts or mounting fixtures and any other condition that may affect proper operation. Any part that is damaged should be properly repaired or replaced by a qualified technician.
5. Do not use the tool if any switch does not turn off and on.

## Operation

1. Never force the tool or attachment to do the work of a larger industrial tool. It is designed to do the job better and more safely at the rate for which it was intended.
2. Do not carry the tool by its power cord.
3. Always unplug the cord by the plug. Never yank the cord out of the wall outlet.
4. Always turn off the machine before unplugging.

**IF YOU QUESTION THE SAFE CONDITION OF THE MACHINE, DO NOT OPERATE IT!**

## Electrical Grounding Instructions

This machine has a three-prong plug(can choose), the third (round) prong is the ground. Plug this cord only into a three-prong receptacle. Do not attempt to defeat the protection the ground wire provides by cutting off the Ground prong. Cutting off the ground will result in a safety hazard and void the warranty.

**DO NOT MODIFY THE PLUG IN ANY WAY. IF YOU ARE NOT SURE ABOUT THE CONNECTIONS, CALL A QUALIFIED ELECTRICIAN.**

## SPECIFICATIONS

<b>Code</b>	<b>505111</b>
Model	SC4/410
Power	1,000W
Spindle Speed	150-2,000rpm
Spindle Taper	MT3
Taper Headstock	MT3
Taper Tailstock	MT2
Centre Height	105mm
Distance Between Centres	410mm
Cross Slide Travel	100mm
Top Slide Travel	70mm
Thread Pitch Range	0.25-3.0 Metric, 8-24 tpi imperial
Overall L x W x H	1,000 x 550 x 410mm
Weight	125kg

<b>Code</b>	<b>505189</b>
Model	SC4/510
Power	1,000W
Spindle Speed	150-2,000rpm
Spindle Taper	MT3
Taper Headstock	MT3
Taper Tailstock	MT2
Centre Height	105mm
Distance Between Centres	410mm
Cross Slide Travel	100mm
Top Slide Travel	70mm
Thread Pitch Range	0.25-3.0 Metric, 8-24 tpi imperial
Overall L x W x H	1,000 x 550 x 510mm
Weight	125kg

The item marked (\*) has different choice, see the label in front of the machine or ask information to your dealer.

## **UNPACKING & PREPARING FOR USE**

Upon receipt, carefully unpack the lathe and inspect to ensure that no damage was suffered in transit and to account for all parts. Should any damage be apparent, or parts are missing, please contact your dealer immediately.

The machine is very heavy. With an assistant, lift it onto a sturdy surface or workbench. Remove all traces of preservative with a good quality solvent. then lightly oil all machined surfaces.

You will notice that, for transit purposes, the cross slide feed handle has been mounted in reverse. Remove it, by unscrewing the hex socket head screw securing it, and mount it the correct way round. Then turn all feed handles to ensure they move freely, evenly and smoothly.

Attach the plastic handles to the rims of the manual feed and tailstock feed hand wheels respectively, ensuring the nuts are tight and the handles spin freely about the bolts, without excessive end play.

The carriage/saddle, cross-slide and compound slide adjustments are all factory set to ensure smooth movement in both directions. However, if the adjustments have been upset during transit (indicated by stiff or erratic movement), refer to 'Settings and Adjustments' for the methods of adjustment.

All hex keys and wrench necessary to carry out the various adjustments are supplied together with a chuck key for the 3-Jaw chuck and a spare fuse. The fuse holder is located on the main control panel.

The three external jaws for the 3-Jaw self centering chuck, extend the capacity of the chuck, and are discussed in greater detail under 'Accessories'.

## **PACKING LIST**

No.	Descriptions	Q'ty
1	Bench lathe	1
2	Instruction Manual	1
3	L Hex. End Wrench S 2.5; 3; 4; 5; 6.	Each 1
4	Double end Wrench 8*10; 14*17; 17*19.	Each 1
5	Key for 3-jaw chuck	1
6	Spindle dead center	1
7	Tailstock dead center	1
8	Change gear set	1 set

## **ACCESSORY'S**

No. 4 <b>Spanner Set</b>	<b>Change Wheel Gears Comprising of:</b>	
No. 1 <b>Main Chuck Key</b>	No.1 <b>127 Teeth</b>	No.2 <b>50 Teeth</b>
No. 4 <b>External Jaws</b>	No.2 <b>100 Teeth</b>	No.1 <b>49 Teeth</b>
No. 4 <b>Internal Jaws</b>	No.1 <b>80 Teeth</b>	No.1 <b>45 Teeth</b>
<b>Set of Allen Keys</b>	No.1 <b>70 Teeth</b>	No.1 <b>40 Teeth</b>
No. 1 <b>2MT Dead Centre</b>	No.1 <b>56 Teeth</b>	No.1 <b>35 Teeth</b>
No. 1 <b>3MT Dead Centre</b>	No.1 <b>55 Teeth</b>	

## **FEATURES**

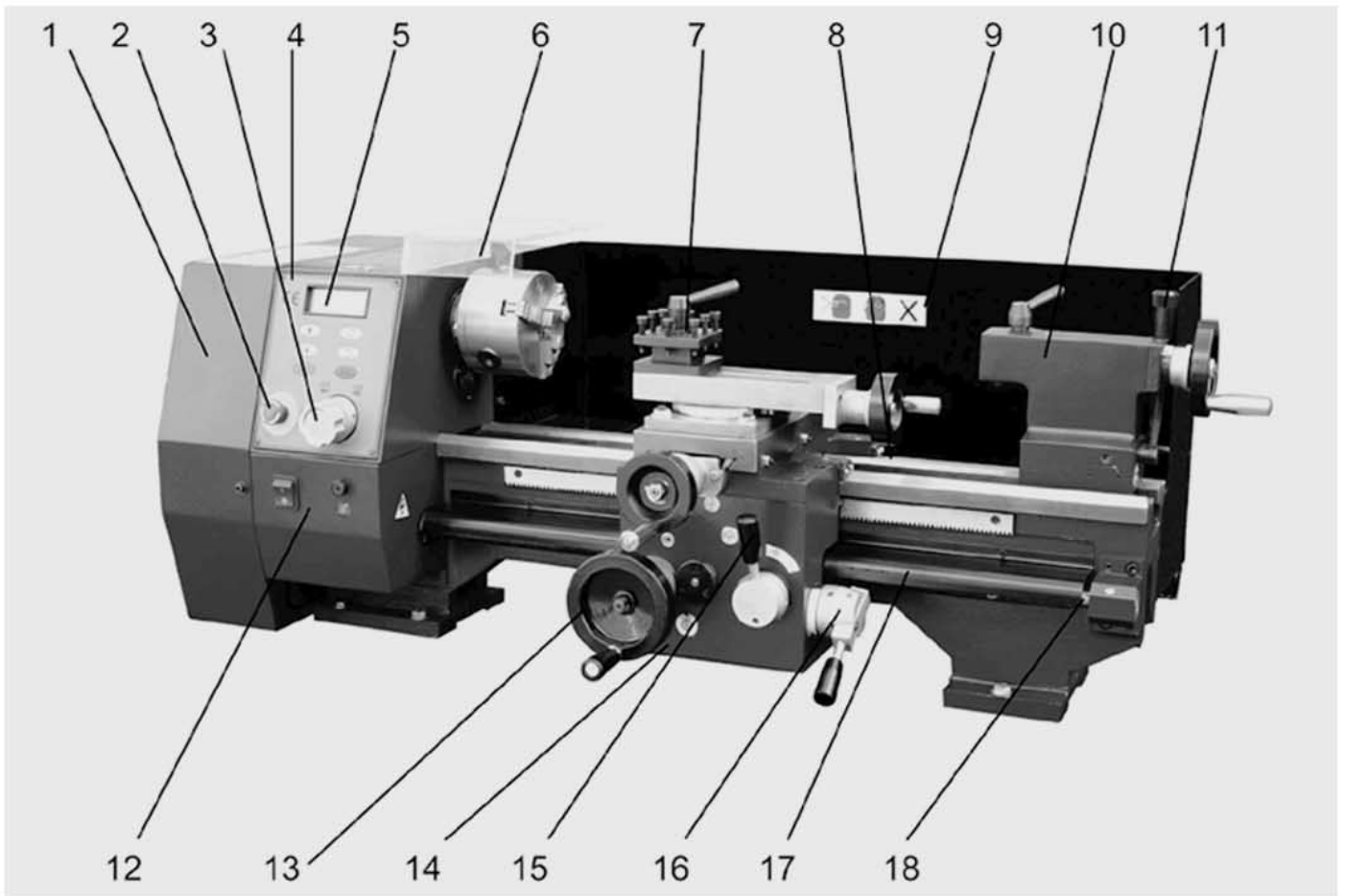

### **Legend**

1. Change gear Cover	11. Quick locking handle
2. Emergency stop switch	12. Spindle box cover
3. Control handle	13. Apron handle
4. Touch panel	14. Apron
5. Spindle speed display	15. Handle
6. Chuck guard with power off	16. X or Y axis auto feeding change handle
7. Tool rest	17. Cover for leadscrew
8. Bed way	18. Leadscrew
9. Splash guard	
10. Tailstock	

## 1. THE HEADSTOCK

The brushless motor provides a direct drive to the Spindle via an internal tooth type belt. Spindle speed is variable, and is regulated by the touch buttons located on the main control panel.

The Spindle is provided with an internal No.3 Morse taper to accommodate a center for use with a face plate or turning clamp.

The 3-jaw, self Centering Chuck is mounted on the Spindle Flange. To remove the chuck, simply remove the three securing nuts to the rear of the flange allowing it to be pulled free together with the three mounting studs.

Three external jaws are also supplied which extend the capacity of the chuck. Their uses and method of assembly is described under 'Accessories'



## 2. THE RUNNING GEAR

The Running Gear is protected by a cover, which is removed by unscrewing the securing hex screws in front of the change gear cover.

The gear train, shown in the picture to the right, transmits drive to the Lead Screw. The Lead Screw acts as a worm and by Operating the Auto Feed lever, which engages a nut with the lead screw, drive is transmitted to the carriage/saddle and consequently the cutting tool, thereby providing a power feed for thread cutting or general turning operations. The rotational speed of the lead screw, and hence the rate of feed of the cutting tool, is determined by the gear configuration. This is explained in greater detail under "Screw cutting".

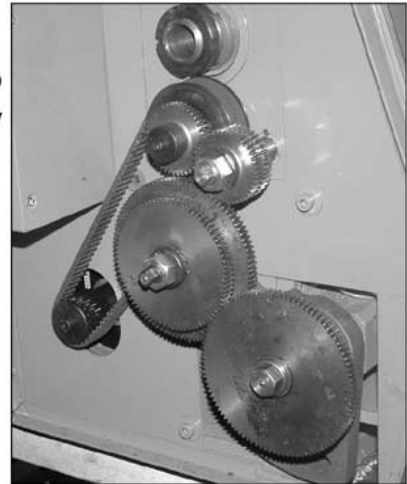

### 2a. SCREW CUTTING

For selection of the required thread pitch please refer to the chart on the gear train cover, select the correct gears from the change wheel set and mount them in the correct sequence. (See fig 1 & 1a)

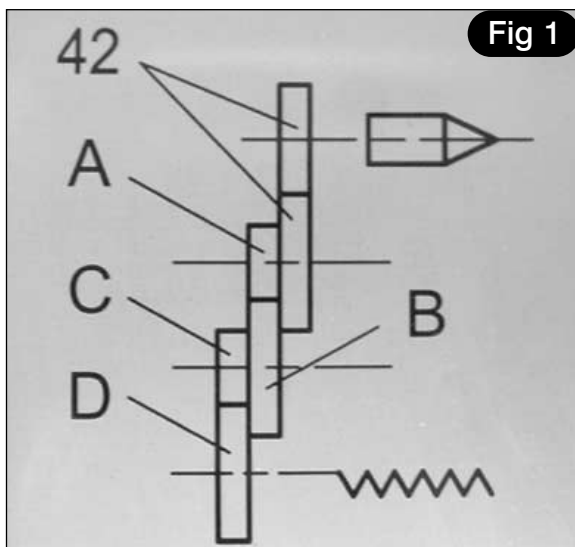

GEAR CHART

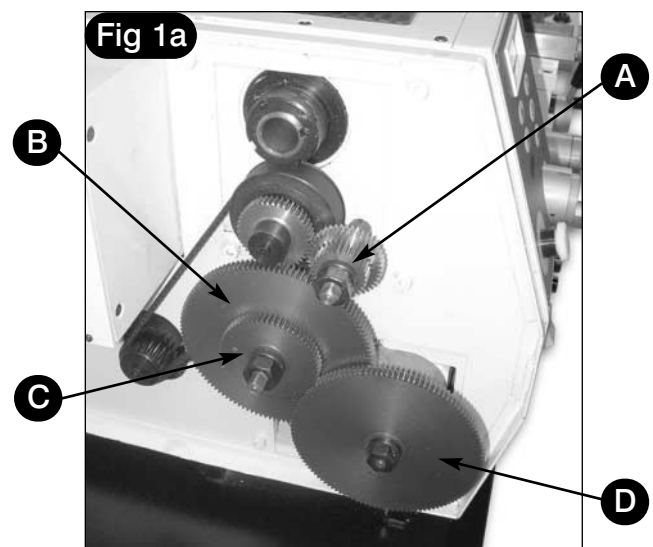

## 2a. SCREW CUTTING CONTINUED

The "C/B" axis is adjusted via the pivoting bracket and clamp bolt as shown. (See figs 2 & 2a)

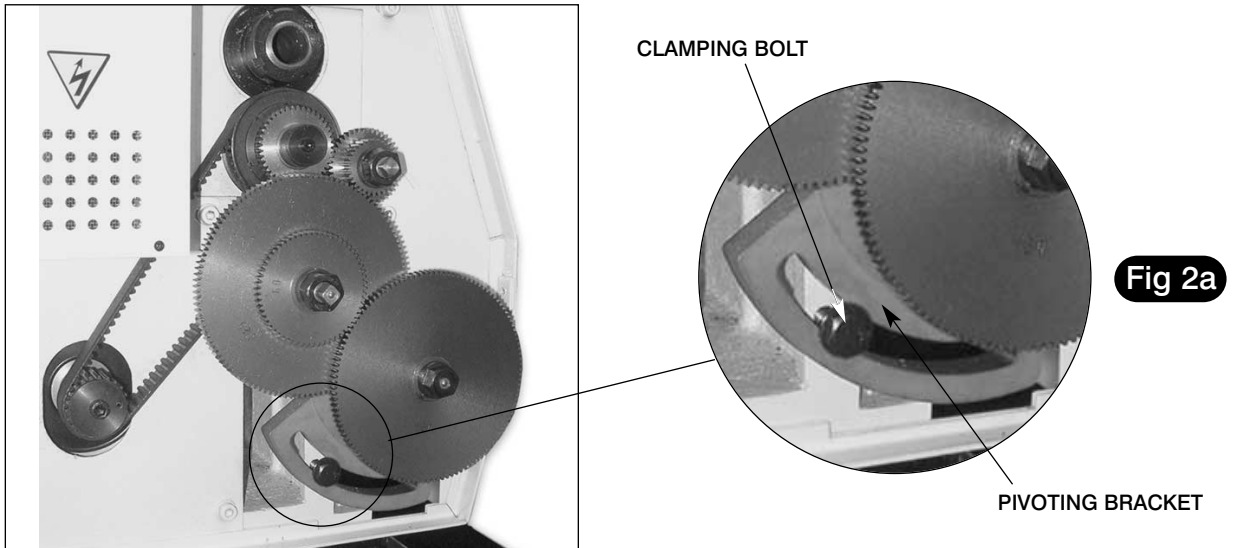

**Fig 2a**

## 3. THE TAILSTOCK

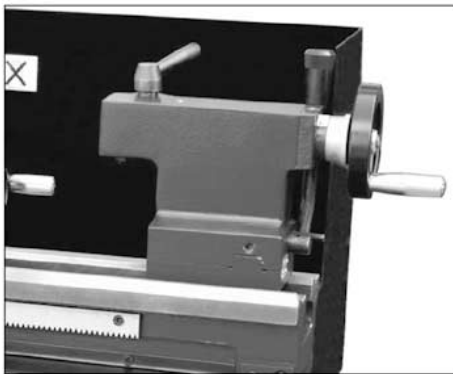

The Tailstock may be moved along the bed to any desired position and is secured in position by a quick lock handle (behind the tailstock and at the right end). The Tailstock spindle carries an internal No.2 Morse taper for use with the Center provided. A Revolving Live Center and Drill Chuck are also available from your dealer. (See Accessories)

## 4. THE CARRIAGE/SADDLE

The Saddle carries the Cross-Slide (1) onto which is mounted the Compound Slide (2) with Tool post (3), allowing intricate and delicate operations to be performed. It may be driven by the Lead screw, via a driver nut, to provide automatic feed when the Auto Feed lever (4), mounted on the Apron (5), is operated. On the right side of the apron, we provide a crossslide auto feeding or longitudinal auto feeding control handle (6)

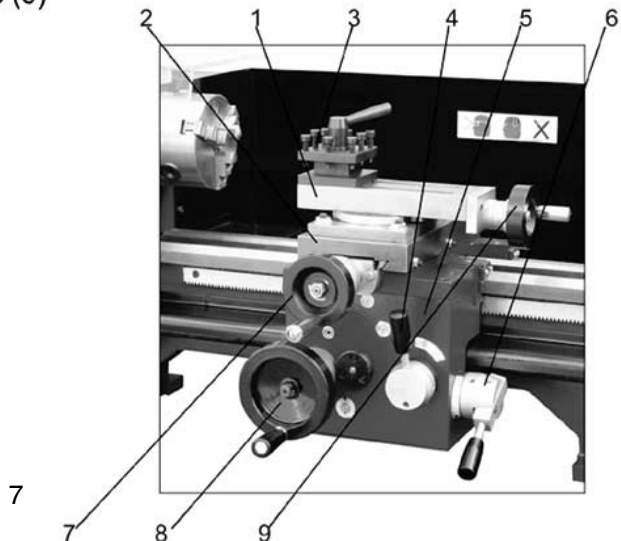

## 4. THE CARRIAGE/SADDLE

The position of the tool is effected by turning the cross-slide feed handle (7), which moves it across the lathe, and the carriage/saddle or manual feed handle (8), which moves it longitudinally. Additionally the compound slide feed handle (9) may be used to move the tool by small amounts at right angles to the cross-slide. The slide may be set at an angle to the cross-slide so that short tapers or bevels may be cut.

The cross-slide and compound slide feeds are provided with a scale. These are used to move the tool by precise amounts – one division being equivalent to (0.02mm). As the feed handle is turned, so does the scale. The scale on the cross-slide feed may also be held stationary whilst the handle is turned, allowing the scale to be 'zeroed'.

The tool post carries 8 square head screws which are used to secure a cutting tool in any desired position. Four tool bits may be mounted for quick and easy changes.

The tool post is rotated by slackening the lever on its top a sufficient amount so the post can be lifted slightly and then turned to the desired position.

ALWAYS ensure the post, and hence the tool, is secured by tightening the lever firmly before attempting to cut.

## 5. THE MOTOR

Disassembly of the motor is not recommended. We use the new type brushless motor, the motor has sufficient power and is secured behind the bed way. For all other servicing and repairs, please contact your dealer.

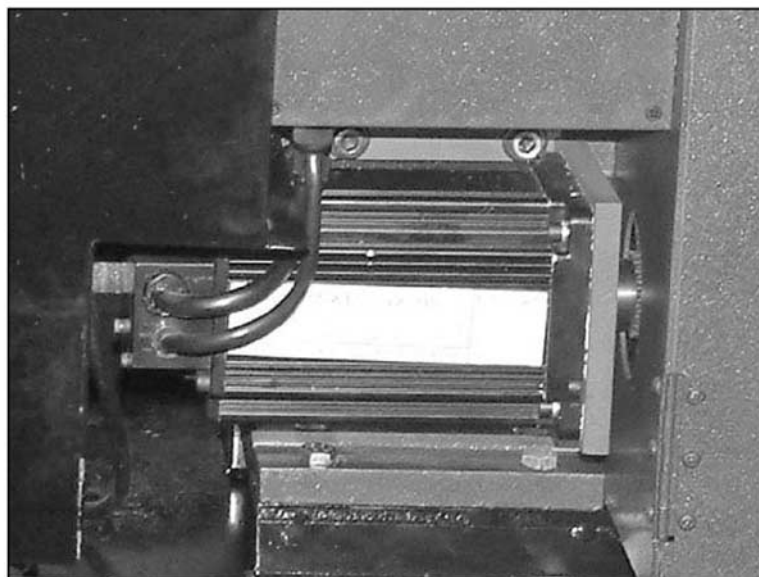



## **INSTALLATION**

### **CAUTION!**

**DO NOT USE THE MACHINE UNTIL INSTALLATION IS COMPLETED AND ALL PRELIMINARY CHECKS HAVE BEEN MADE IN ACCORDANCE WITH THIS MANUAL.**

### **MOUNTING THE LATHE**

The lathe should be mounted onto the purpose made stand or on a sturdy workbench of sufficient height so that you do not need to bend your back to perform normal operations. The machine is very heavy, so get assistance from another person when moving the machine.

Provide adequate overhead lighting so that you will not be working in your own shadow.

We strongly recommend that the machine be firmly bolted to a sturdy workbench using the tapped holes used to secure the feet to the lathe. This is to provide added stability and consequently, safety.

Alternatively, if you do not wish for a permanent installation, you may secure the lathe to a 30 mm thick plywood board with a minimum recommended dimension, the mounting holes being centralized on the board. When the lathe is in use, the board should be clamped to workbench using with G- clamps.

### **STARTING PROCEDURE**

#### **A. DURING INSTALLATION – INITIAL START**

Be sure the cross-slide is well away from the chuck, and the automatic feed lever is in its disengaged position, (i.e. lever is UP). Insert the electric plug into the wall socket.

Press the power switch to "I" position, at the same time the green lamp will illuminate. Then release the Emergency stop switch. The top display will show "0000" (this show the spindle speed rpm). First press the "start" button and press the "↑" button the spindle speed will increase, if you press the "↓" button the spindle speed will decrease. If you need to change the spindle rotation direction press the Forward or Reverse button respectively. Need stop the machine can press the "stop" button or the Emergency stop switch.

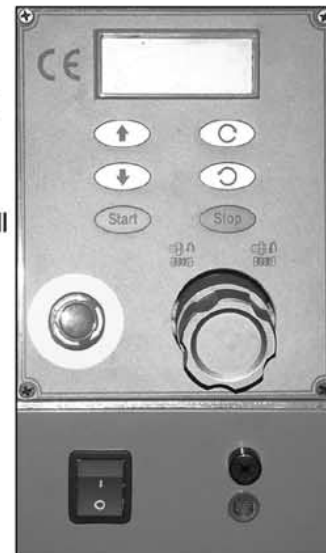

Notice: on the main panel you can find a knob, some times when we use the added Milling function we need to stop the spindle rotation you can turn the knob to right the position, when need the spindle running turn it to left position.

**Note: The chuck guard must be in the lower position as there is a interlock switch proventing the machine operating with the guard in the raised position.**

## **LATHE MAINTENANCE**

Your C4 bench lathe is a precision tool. In order to maintain this precision and prolong its useful life, it is advised that you follow the recommended daily and periodic maintenance tables printed below.

### **Daily and Periodic Maintenance**

#### **Daily Pre-use**

1. Using an oil can with a narrow nozzle, oil all the oil points on the machine, incl.  
A) Saddle (4), B) tailstock (2), C) traverse slide (1), D) compound slide (2), E) leadscrew gearbox (2), and F) leadscrew end bearing (1).
2. Move the traverse and compound slides to give access to their drive shaft threads and lightly coat with oil, work the oil up the threads to lubricate the thread followers.
3. Spray-oil the slides and the lathe bed, exercise the saddle and the slides to spread the oil to all surfaces, both hidden and visible.
4. Spray up under the rack cover to lubricate the rack. (G)
5. Apply oil to the change gears and their axle mountings. (H)

#### **Daily after-use**

1. Clean all swarf and chips away from the machine bed, slide surfaces, and the tool post.
2. Exercise the slides and ensure no swarf etc., is lodged in the drive shaft tunnels.
3. If you have been using 'suds' make sure the machine is thoroughly dried off. Clear the suds tray of all swarf and chips, especially around the drain.
4. Check the tool, ensure it is usable the next time, if not re-sharpen or replace the tool tip.
5. Lightly oil spray all the machine beds and surfaces, and the tailstock barrel.
6. Clean and lightly oil any tools you may have been using (centres, drill chucks, spanners chuck keys etc, and put them away.
7. Switch off the power supply. Disconnect the plug.
8. Cover the machine over with a dust cloth.

#### **Weekly**

- a) Check the belt tension.
- b) Check the tautness of the slides.
- c) Check the level of the suds reservoir. (if you are using suds).

#### **Accessories**

May we recommend the following products for use with your C4 lathe.

Grease - Rocol Sapphire 2 (Part number: 810129).

Lubricant - Rocol Slideway lubricant spray (Part Number: 810141).

Cutting Fluid - Rocol Multisol cutting fluid (Part Number: 810140).

There are numerous accessories listed for the machine listed in the Axminster catalogue in section 1

# LATHE MAINTENANCE (OIL LUBRICATION POINTS)

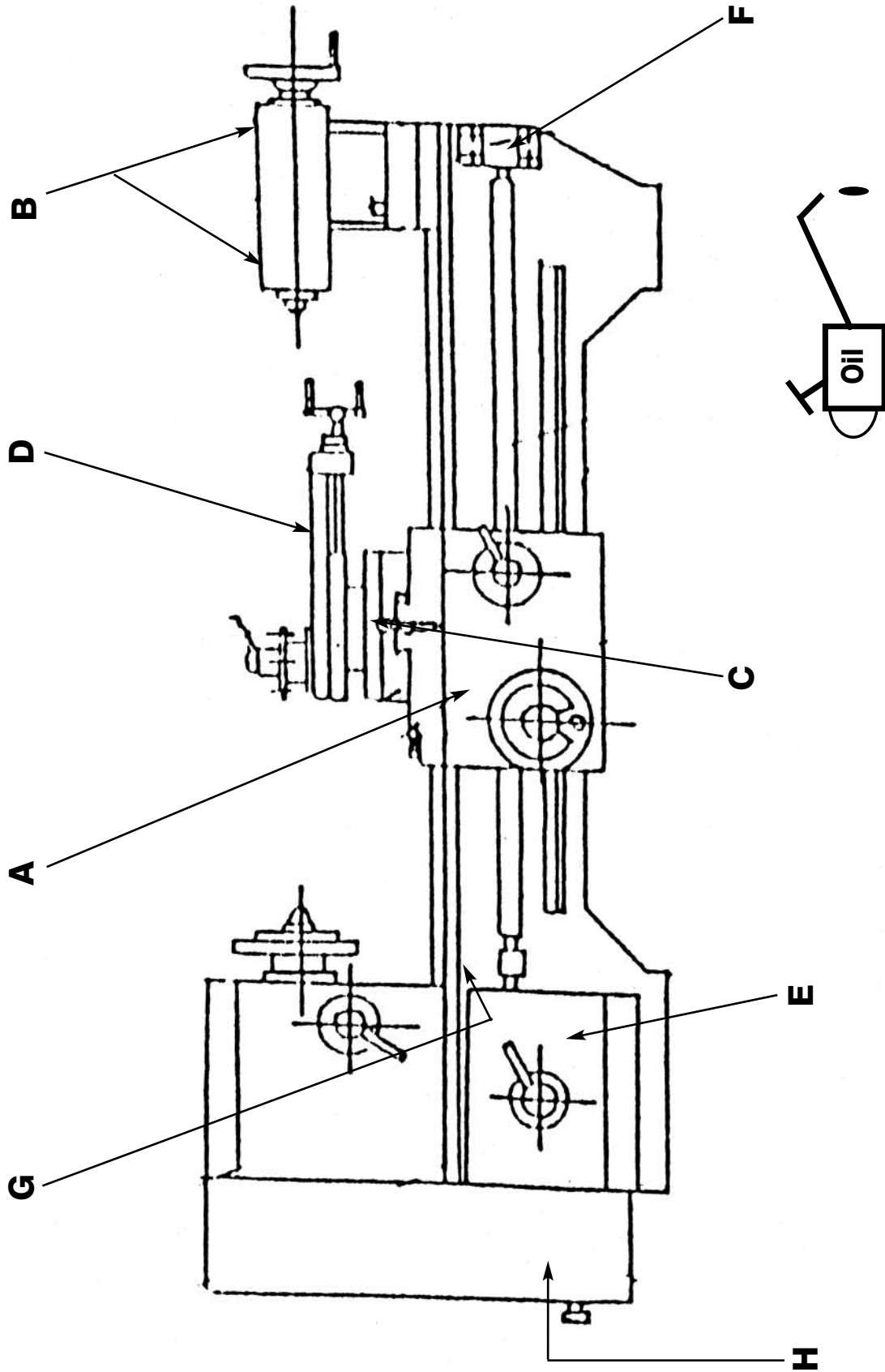

**Parts drawing I**

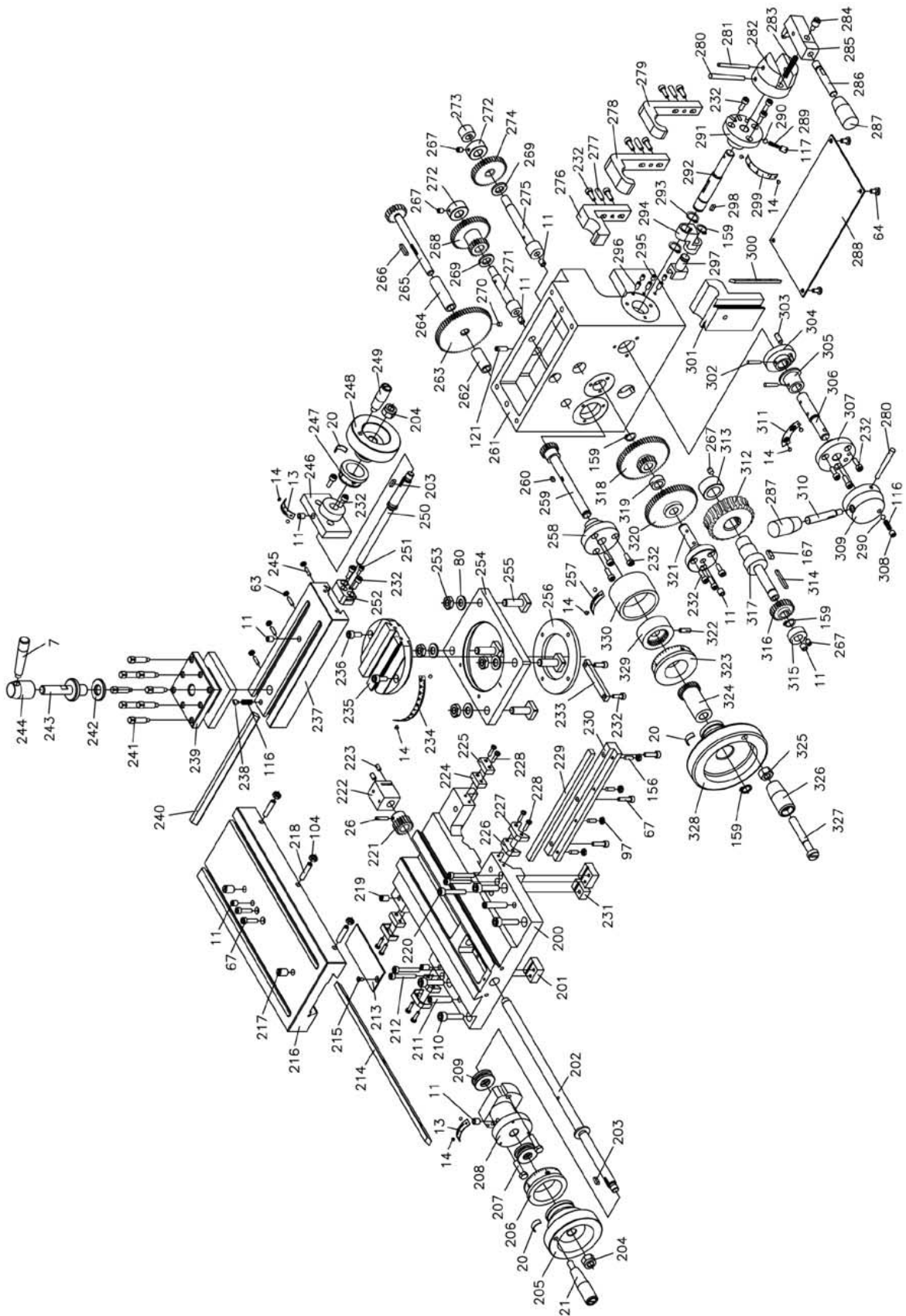

**Parts drawing II**

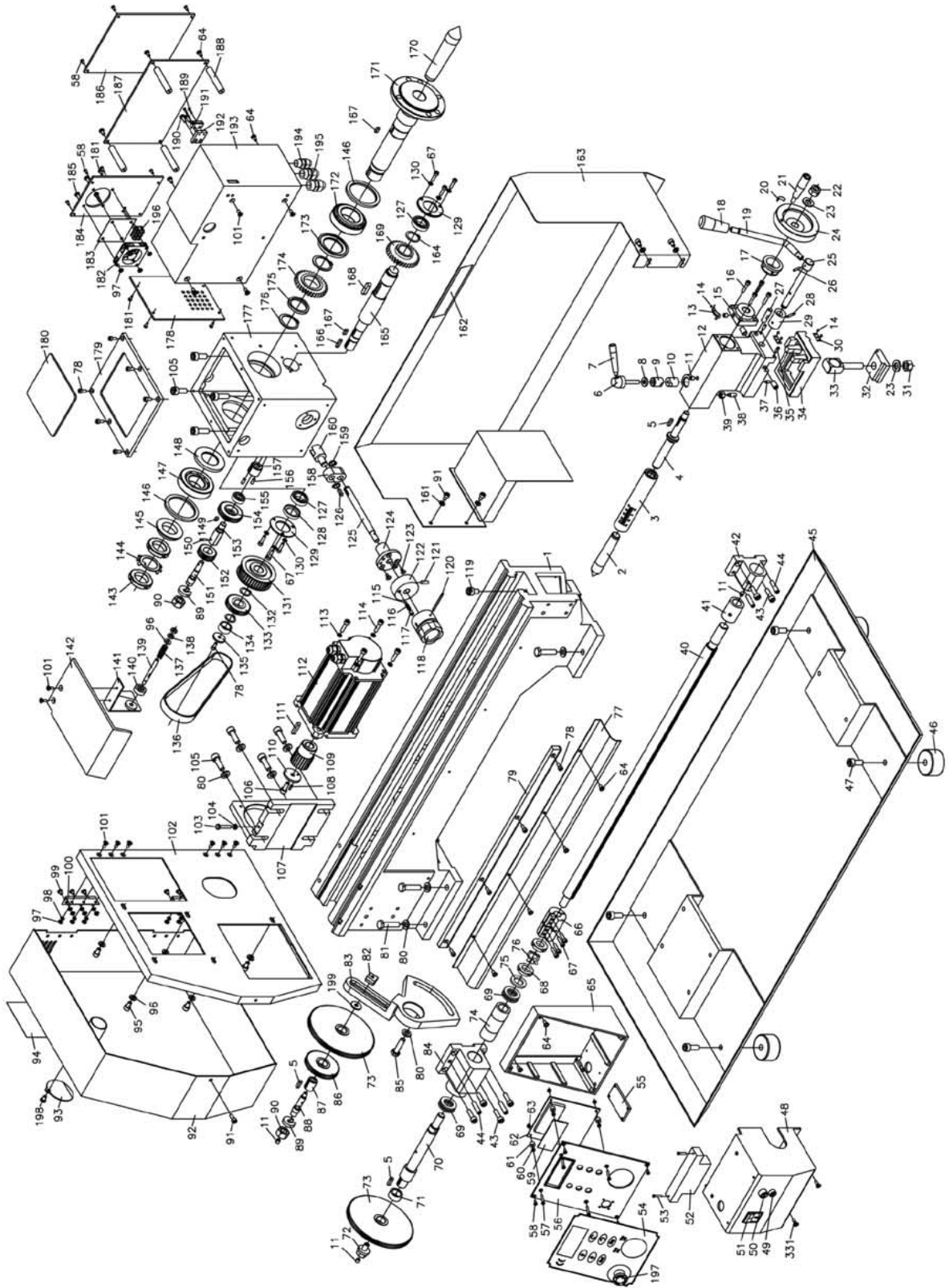

## **Parts list (I)**

<b>No.</b>	<b>Description</b>	<b>Q'ty</b>	<b>No.</b>	<b>Description</b>	<b>Q'ty</b>
1	bed way	1	43	screw M6*20	6
2	tailstock center	1	44	pin 6*26	4
3	tailstock sleeve	1	45	chip tray (optional parts)	1
4	lead screw	1	46	rubber foot (optional parts)	4
5	key 4*16	3	47	screw M8*20 (optional parts)	6
6	lock shaft	1	48	protecting cover of bracket	1
7	knob	2	49	green lamp	1
8	adjust washer	1	50	fuse	1
9	lock sleeve	1	51	switch	1
10	lock nut	1	52	electric filter	1
11	oil cup 6	13	53	screw M3*16	2
12	tailstock casting	1	54	switch film	1
13	scale lable	3	55	pc board	1
14	rivet 2*4	18	56	switch label	1
15	lead screw support	1	57	screw M3*20	4
16	screw M4*20	4	58	screw ST2.9*9.5	12
17	dial	1	59	digital readout guard	1
18	handle M8*50	1	60	compression sping 0.7*4.5*7	4
19	knob	1	61	pc board stepping	4
20	speing	4	62	pc board	1
21	long handle M6*50	2	63	nut M3	8
22	lock nut M10	1	64	screw M4*8	19
23	washer 10	2	65	control box	1
24	handle wheel	1	66	joint sleeve of leadscrew	1
25	rotating shaft	1	67	screw M4*16	15
26	pin 3*16	2	68	nut M16*1.5	2
27	limit shank	1	69	ball bearing 8103	2
28	pin 3*20	1	70	leadscrew connecting shaft	1
29	elcentric sleeve	1	71	thick washer	1
30	zero position lable	2	72	bolt	1
31	nut	1	73	change gear	2
32	tailstock clamp plate	1	74	copper bush I	1
33	lock bolt	1	75	washer	1
34	stand	1	76	lock washer 16*22	1
35	screw M4*12	2	77	protecting cover of lead	1
36	screw M8*14	2	78	screw M4*10	11
37	screw M4*10	1	79	rack	1
38	screw M6*16	1	80	washer 8	15
39	nut M6	1	81	bolt M8*35	6
40	lead screw	1	82	square nut	1
41	copper bush II	1	83	support plate	1
42	bracket	1	84	bracket	1

**Parts list ( II )**

<b>No.</b>	<b>Description</b>	<b>Q'ty</b>	<b>No.</b>	<b>Description</b>	<b>Q'ty</b>
85	bolt M8*30	1	127	bearing 61903	2
86	change gear	1	128	spacer	1
87	bearing	1	129	cover	2
88	bolt	1	130	washer 4	6
89	open washer	2	131	spindle pully	1
90	nut M12	2	132	check ring 16	2
91	screw M5*8	5	133	gear	1
92	gear box cover	1	134	washer	1
93	small cover	1	135	check ring	1
94	thread and feeding lable	1	136	timing blet	1
95	screw M6*10	5	137	compression sping	1
96	washer 6	6	138	nut M6	2
97	nut M4	22	139	small shaft	1
98	spring washer M4	12	140	damp sleeve	1
99	screw M4*6	6	141	splash guard support	1
100	hinge 62*33	2	142	guard	1
101	screw M4*10	12	143	nut M27*1.5	2
102	rear plate of gear ox cover	1	144	lock washer 27*37	1
103	bolt M5*25	1	145	spacer	1
104	nut M5	4	146	oil ring	2
105	screw M8*25	6	147	bearing 30206	1
106	screw M6*16	1	148	oil ring	1
107	motor support	1	149	key 4*8	1
108	pin 3*10	1	150	pin B3*14	1
109	pully	1	151	spindle bolt	1
110	washer	1	152	gear	1
111	key 5*25	1	153	intermediate shaft	1
112	brushless motor	1	154	gear	1
113	spring washer 5	4	155	bearing 60018	1
114	screw M5*20	4	156	screw M4*12	6
115	steel ball 4	1	157	inlay block	1
116	compression sping 0.8*4*12	3	158	shifting arm	1
117	screw M6*8	2	159	check ring 10	6
118	knob	1	160	shifting block	1
119	screw M8*12	1	161	washer 5	4
120	pin 3*40	1	162	safty lable	1
121	screw M5*16	2	163	rear splash guard	1
122	finding dial	1	164	ring 21	1
123	screw M4*8	3	165	H/L gear shaft	1
124	fingding sleeve	1	166	key 4*18	1
125	small shaft	1	167	key 4*12	3
126	key 4*14	1	168	key 6*25	1

### Parts list ( III )

No.	Description	Q'ty	No.	Description	Q'ty
169	H/L gear	1	211	pin 6*30	2
170	spindle center	1	212	screw M4*30	4
171	spidle	1	213	cover	1
172	bearing 32007	1	214	gib strip	1
173	oil ring	1	215	screw M3*6	1
174	spindle gear	1	216	cross slide	1
175	spacer	1	217	screw M8*12	2
176	check ring 30	2	218	screw M5*25	3
177	head stock body	1	219	screw M6*10	2
178	cover of electric box	1	220	screw M5*30	1
179	cover	1	221	gear	1
180	rubber	1	222	nut	1
181	screw ST2.9*9.5	6	223	screw M4*8	2
182	small fan	1	224	oil-stopping felt	2
183	protect mesh	1	225	protecting panel	2
184	small cover of electric box	1	226	oil-stopping felt	2
185	screw M4*16	4	227	protecting panel	2
186	big cover of electric box	1	228	screw M3*12	8
187	pc board	1	229	gib strip	1
188	stepping	4	230	rear clamp	1
189	screw M2*10	2	231	rear clamp	1
190	screw M4*12	2	232	screw M4*12	24
191	mrico switch	1	233	finding block	1
192	bottom plate of mrico switch	1	234	angle ruler	1
193	electric box	1	235	cutter rest revolving dial	1
194	lock connect M12	1	236	screw M5*12	2
195	lock connect M16	2	237	compound rest	1
196	connection pole	1	238	positing pin	1
197	emergency stop switch	1	239	tool rest	1
198	screw M5*8	1	240	gib strip	1
199	washer	1	241	screw M6*20	8
200	saddle	1	242	adjusting washer	1
201	front clamp	2	243	fuselage	1
202	lead screw	1	244	clamping lever	1
203	key 3*10	2	245	screw M3*12	4
204	lock nut M8	2	246	leadscrew support	1
205	handle wheel	1	247	dial	1
206	dial	1	248	handle wheel	1
207	bolt M5*20	2	249	knob M6*32	1
208	bearing seat	1	250	lead screw	1
209	bearing 8100	2	251	screw M3*8	1
210	screw M6*25	4	252	nut	1



**Parts list IV**

No.	Description	Q'ty	No.	Description	Q'ty
253	nut M8	4	295	screw M4*6	3
254	stand	1	296	screw M4*8	3
255	T bolt	4	297	shifting block	1
256	rotating clamp	1	298	key 3*8	1
257	lable	1	299	cross feeding lable	1
258	shaft I sleeve	1	300	gib strip	1
259	shaft I gear shaft	1	301	half nut	1
260	key 3*6	1	302	pin 3*18	2
261	apron	1	303	pin 5*12	1
262	shaftII sleeve I	1	304	shifting dial	1
263	shaft II gear	1	305	lock wheel	1
264	shaft II sleeve II	1	306	shaft VII	1
265	shaft II gear shaft	1	307	finding flange sleeve	1
266	key 3*16	1	308	screw M6*6	1
267	screw M5*8	4	309	handle seat I	1
268	H/L gear of shaft V	1	310	bolt	1
269	washer	2	311	lable	1
270	screw M4*6	1	312	worm wheel	1
271	shaft V	1	313	shaft VI sleeve I	1
272	ring 10	2	314	key 3*28	1
273	shaft sleeve	1	315	shaft VI sleeve II	1
274	shaft IV gear	1	316	H/L gear	1
275	shaft IV	1	317	shaft VI	1
276	leadscrew support	1	318	shaft III H/L gear	1
277	pin B4*16	3	319	spacer	1
278	leadscrew supporting clasp II	1	320	shaft III gear	1
279	leadscrew supporting clasp I	1	321	shaft III	1
280	pin 4*45	2	322	screw M4*14	1
281	pin 4*40	1	323	dial	1
282	handle seat II	1	324	meshing gear of wheel	1
283	compression spring 0.8*5*30	1	325	nut M8	1
284	finding screw	1	326	handle	1
285	active handle block	1	327	screw M8*55	1
286	handle shank	1	328	handle wheel	1
287	long handle sleeve M8*40	2	329	inner gear sets	1
288	apron botton cover	1	330	protecting sleeve	1
289	Compression spring 0.6*3.5*12	1	331	screw M4*12	2
290	steel ball 5	2			
291	limit flange sleeve	1			
292	shifting knob	1			
293	check ring 12	2			
294	shifting arm	1			



## NOTES

**AXMINSTER**

**Engineer**  
**SERIES**



Code **505112**

# **M4MA Milling Attachment**

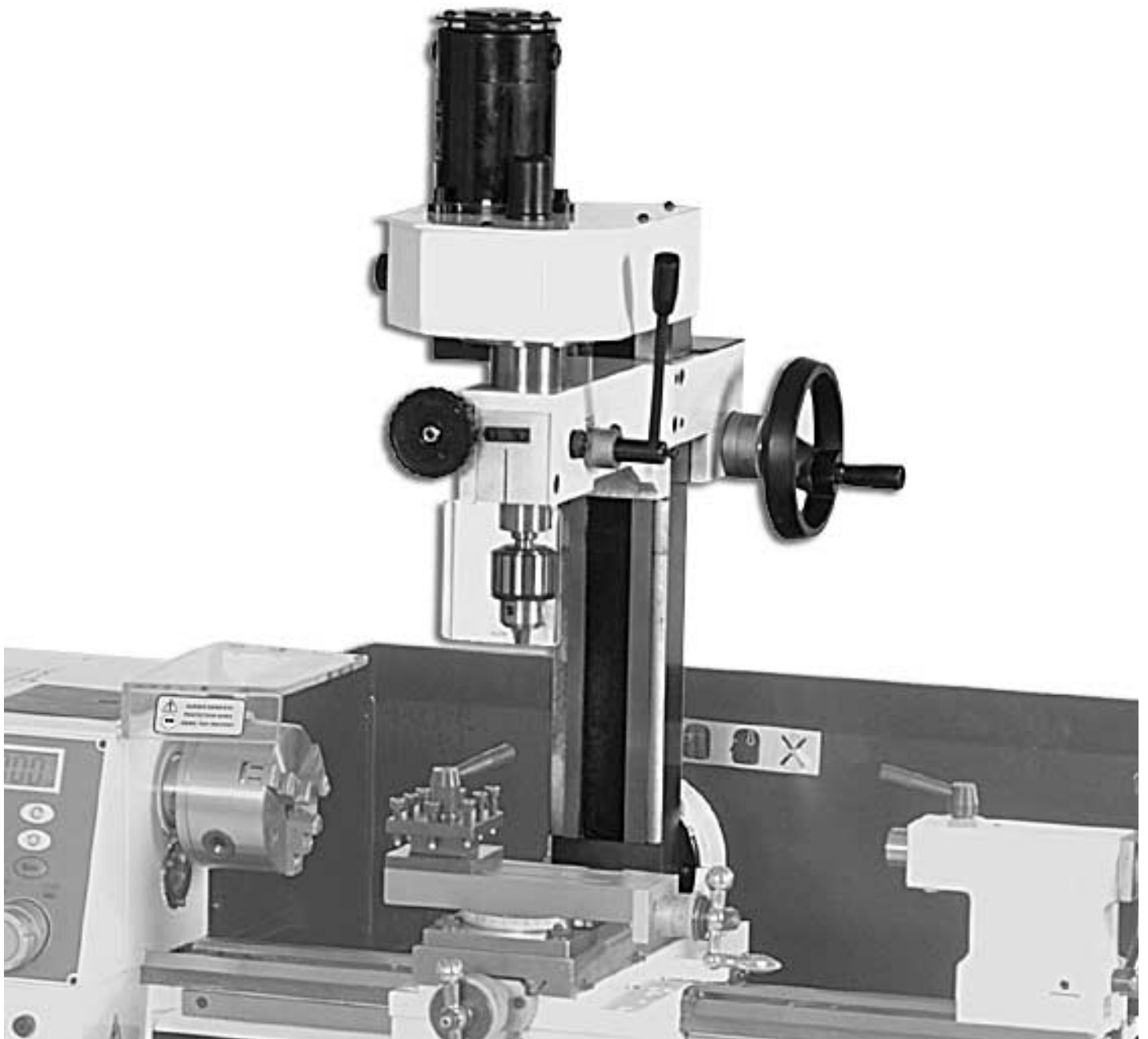

## DECLARATION OF CONFORMITY

The undersigned, Ole Stilling authorised  
by Shanghai SIEG Machinery Co.,Ltd.  
No.555 Caofeng Rd., South to No. 17 Bridge of  
Caoan Rd., Shanghai

declares that this product:

**(Micro Mill) M4MA**

manufactured by Shanghai SIEG Machinery Co.  
is in compliance with the following standards or  
standardisation documents in accordance with  
Council Directives

**EN55014-1:2000, EN55014-2:1997  
EN61000-3-2:2000, EN61000-3-3:1995**

**(89/336/EEC amended by 93/68/EEC)**

### WHAT'S IN THE BOX

Quantity	Item	Model Number
1 No.	Mill with Chuck and Draw Bar fitted	M4MA

#### Box containing:-

1 No.	Chuck Key
1 No.	Nipple 'C' Spanner 28mm-32mm
4 No.	'T' Slot Keepers
1 No.	Tommy Bar
1 No.	Oiling Bottle
1 No.	Spare Fuse (250v x 1 Amp)
1 No.	Guarantee Card

 **Please read the Instruction Manual prior to using your new machine; as well as the installation procedure, there are daily and periodic maintenance recommendations to help you keep your machine on top line and prolong its life. Keep this Instruction Manual readily accessible for any others who may also be required to use the machine.**

Having unpacked you machine and its accessories, please check the contents against the equipment list "What's in the box", if there are any discrepancies, please contact Axminster Power Tool Centre using the procedures laid down in the catalogue. Please dispose of the packaging responsibly, much of the material is bio-degradable. The machine and its accessories will arrive coated with heavy corrosion preventative grease. This will need to be cleaned from the machine, its components and accessories prior to it being set up and commissioned. Use coal oil, paraffin or a proprietary degreaser to remove the barrier grease. Be warned, it will stain if you splash it on clothing etc., wear overalls, coverall et al., rubber gloves are also a good idea, as is eye protection if your cleaning process tends to be a little bit enthusiastic. After cleaning, lightly coat the exposed metal surfaces of the machine with a thin layer of light machine oil. N.B If you used paraffin/kerosene make sure you apply this thin film sooner rather than later.

## SPECIFICATIONS

<b>Code</b>	<b>505112</b>
Power Supply	230V a.c. 50Hz
Motor	220V d.c. 150W
Quill Travel	30mm
Spindle Speeds	Low Gear 100-1000rpm (variable) High Gear 100-2000 rpm (variable)
Reversing Method	Electrical
Quill Mandrel Taper	2MT
Draw Bar Thread	M10
Drilling Capacity	10mm
End Mill Capacity	10mm
Face Mill Capacity	20mm
Weight	25 kg

## DEFINITIONS

- 'X' Axis. This is the axis described by the work table as it is moved side to side. Normally, movement that moves the tool to the right in the workpiece is referred to as +ve 'X', and movement that moves the tool to the left in the workpiece is referred to as -ve 'X'. Where the initial position of the tooling and the worktable is designated 0,0. (Horizontal plane only).
- 'Y' Axis. This is the axis described by the work table as it is moved from front to back. (Traverse) Normally movement that moves the tool to the front in the workpiece is referred to as -ve 'Y', and movement that moves the tool to the rear in the workpiece is referred to as +ve 'Y'. Where the initial position of the tooling and the worktable is designated 0,0.(Horizontal plane only).
- 'Z' Axis This is the axis described by the worktable in the vertical plane. (Not possible with this machine). However, to establish a point in space, the co-ordinates can be transferred to the 'tip' of the tooling, whereby, if we assume that the tool and the worktable in their initial positions, where designated 0,0,0, (Horizontal and vertical planes) any point above the tool tip is referred to as +ve 'Z', and any point below the tool tip is referred to as -ve 'Z'

## INITIAL ASSEMBLY

Fig A



Step 1

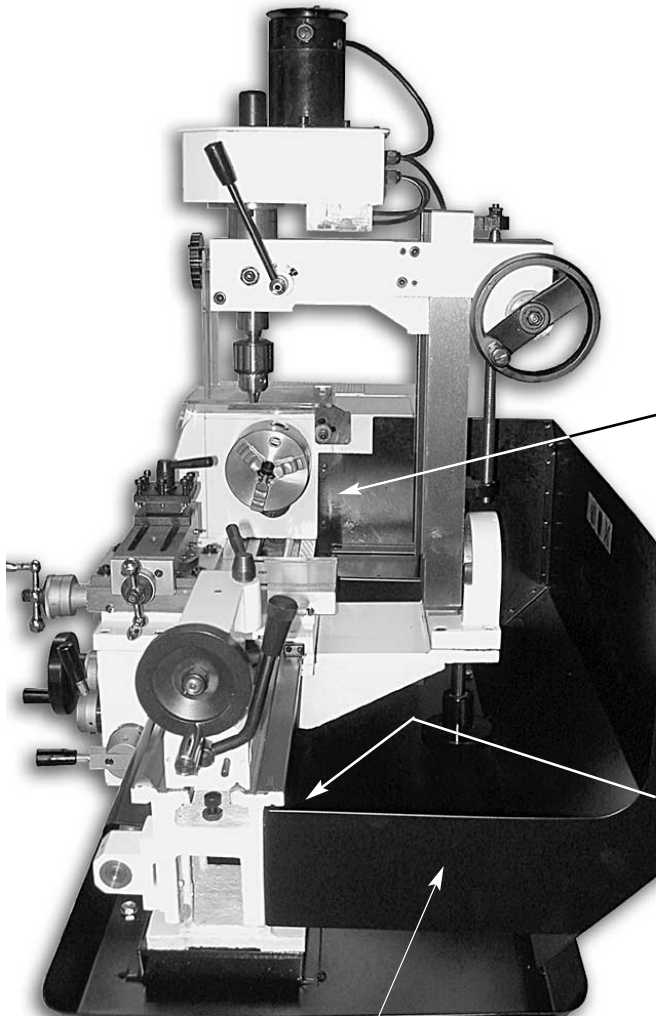

Splash guard

Remove the four M5 caphead bolts using a 4mm allen key as shown in figures A & B and remove the splash guard.



Fig B



**When mounting the Mill to the Lathe, we strongly advise you get the assistance of another person because of the weight of the machine.**

# INITIAL ASSEMBLY

Mill assembly

## Step 3

Lower the mill assembly down onto the angle support casting and secure in place using four M8 caphead bolts. (See figs C & E)

Fig C

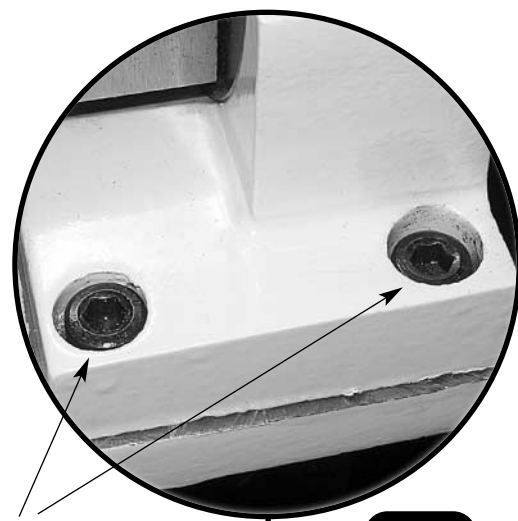
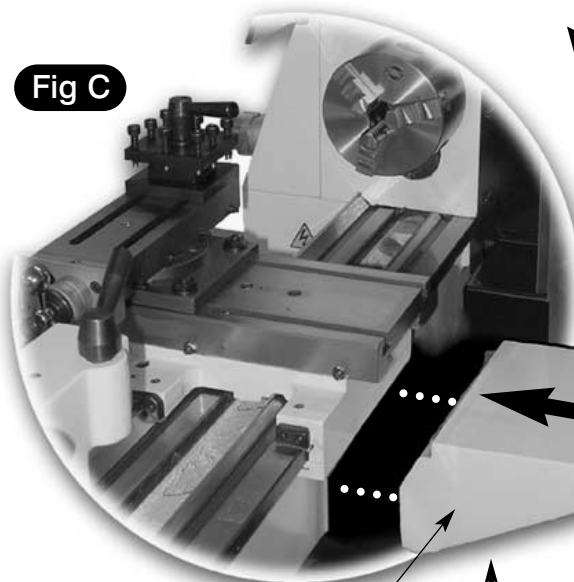

M8 Caphead bolts

Fig E

## Step 4

Tip the lathe forward and have your assistant thread the support leg up into the angle support casting. (See figs C & F ) Adjust the the support leg until it makes contact with the surface of your bench or stand, tighten the lock nut to lock the leg in position.

Angle support casting

Fig D

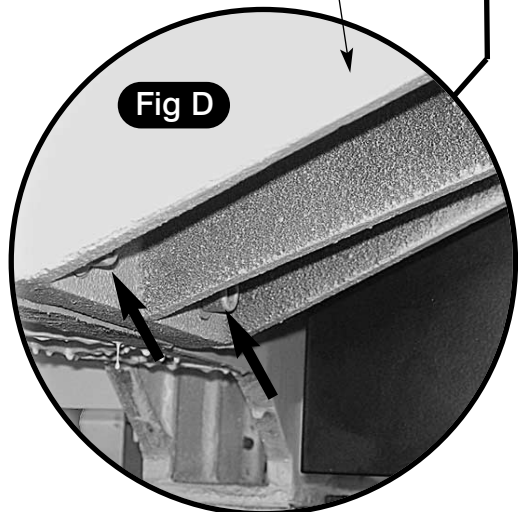

## Step 2

Offer up and secure the angle support casting to the side of the lathe bed using four M10 caphead bolts/ washers and tighten securely. (See figs C & D) **DO NOT OVERTIGHTEN**

Lock nut

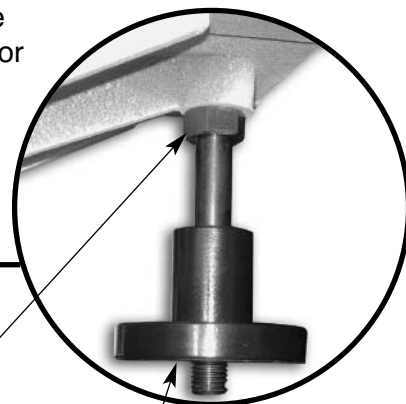

Leg Support

Fig F

Make sure that everything is secure then replace the splash guard as described on page 23.



## INITIAL TESTING



**Please read the section entitled Identification and Parts description so that you may more easily identify the parts to which reference is made in the text.**

### Testing

When the Mill is mounted to your satisfaction, proceed as follows:-

- a)** Close the chuck jaws
- b)** Check the millhead is 'locked' in position on the column.
- c)** Check that all loose items are removed from the worktable.
- d)** Set the worktable approximately mid-positioned under the chuck jaws.
- e)** Check the speed control is switched OFF (fully anti-clockwise).
- f)** Check the Forward/Off/Reverse Switch is in the Off position
- g)** Select L (Low) on the gear box .
- h)** Connect the machine to the mains supply and switch power on.
- i)** Turn the Speed Control Switch On (Clicks On) and Select Forward on the Forward/Off/Reverse switch.
- J)** Check the Amber LED (Fault Light) is illuminated and the green light is illuminated.
- k)** Switch the Speed Control Switch Off ( Clicks Off) and the Amber Led is now Off and the Green light stays on.
- l)** Turn the Forward/Off/Reverse switch to Off position (Clicks Off) all lights are now off.
- m)** Select Forward on the Forward/Off/Reverse switch.
- n)** Turn the Speed Control Switch On and advance until the Chuck starts to rotate.
- o)** Turn the Forward/Off/Reverse switch to Off position, check that the machine stops, turn the Forward/Off/Reverse switch to Forward, check that the Green light comes on and the Amber LED comes on and the machine does not start. Turn all switches off (All lights are off).
- p)** Turn Forward/Off/Reverse switch to Forward.
- q)** Turn the Speed Control Switch On (Clicks On), advance until the chuck starts to rotate.
- r)** Over a period of approximately 5 minutes advance the speed in stages to maximum, run at maximum for at least 2 minutes, check that there is nothing untoward, (no excessive vibration, speed progression is smooth etc.). Stop the spindle and change the gear selector to H (High), carry out the previous check. Repeat the checks with the motor set in reverse.
- s)** If all the above checks are correct, stop the spindle, (turn the speed control to zero and select Off on the direction selector switch. Ensure the fine feed control is disengaged, using the 'coarse' feed lever handle, exercise the quill up and down, check the movement is smooth and precise.
- t)** Select the fine feed function, (if necessary 'joggle' the feed hand to enable the gears to mesh). Raise and lower the quill using the fine feed control. Check the movement is smooth and precise, there are no hard spots and the feed doesn't bind up.
- u)** Ensure the head lock clamp is loosened and exercise the rise and fall, driving the head up and down the tool post. Check the movement is smooth and tight. Leave the head fairly well down the tool post for the next check.
- v)** Loosen the tilt clamp bolts, and tilt the tool post to the left and right, clamp the tool post in an arbitrary position and tighten the clamp bolts. Check that the tool post remains locked in place.
- w)** If all the above checks are correct, your mill is now ready for use.

## PARTS IDENTIFICATION AND DESCRIPTION

Please take some time to identify the various parts of your machine so that you are familiar with the terminology we will use to enable you to set up and operate your Mill safely and correctly.

<b>Main tool post</b>	This is the column of the mill, it is an 65 x 50 bar with a dovetail slide machined on the front onto which the milling head is mounted, the lower part is the circular 'boss' for the tilt assembly. On the left side of the post a scale, graduated in mm's, is mounted to read against an adjustable pointer mounted on the head casting.
<b>Rise and fall</b>	The Rise and Fall drive screw is anchored in a machined housing at the top of drive screw the main tool post. It has a wheel and rod handle keyed to the shaft to enable the screw to be turned. It is fed through a threaded dog that is bolted to the head casting allowing the head to be moved up and down. Viewed from above the drive screw is turned clockwise to raise the head and anti-clockwise to lower it.
<b>Tilt housing</b>	The tilt housing is mounted to the base casting using 4 bolts. The tilt 'boss' of the main tool post is mated to the housing and clamped by a further 4 bolts. The main tool post can tilt 45 (degrees) from the vertical either left or right. There is an adjustable pointer and a scale mounted on the housing to give an indication of the amount of tilt that has been applied.
<b>Milling head</b>	<b>This is the 'milling machine' and the descriptions of its various parts and components are detailed as follows:-</b>
<b>Milling head casting</b>	The main casting to which all the components are attached. The head has a dovetail housing machined at the rear, which allows the casting to be fitted to the Main Tool Post. The left side of the dovetail slide is fitted with a gybe strip to maintain the fit.
<b>Head clamp</b>	Located between the gybe strip adjusters and locknuts is an handled bolt that clamps the gybe strip against the slide to effect a locking action for the rise and fall of the head.
<b>Rise and fall drive screw dog</b>	An 'L' shaped casting that is threaded to accept the rise and fall drive screw, and is driven along the thread when the screw is turned. As it is bolted to the milling head, the head will therefore follow its movement as it is being driven.
<b>Motor and gearbox</b>	The motor and gearbox assembly are mounted above the main head casting at the top of the arbor sleeve. The motor drive is geared through to the spindle with an intermediate 2:1 gearbox.

# MACHINE ILLUSTRATION OF THE MILL

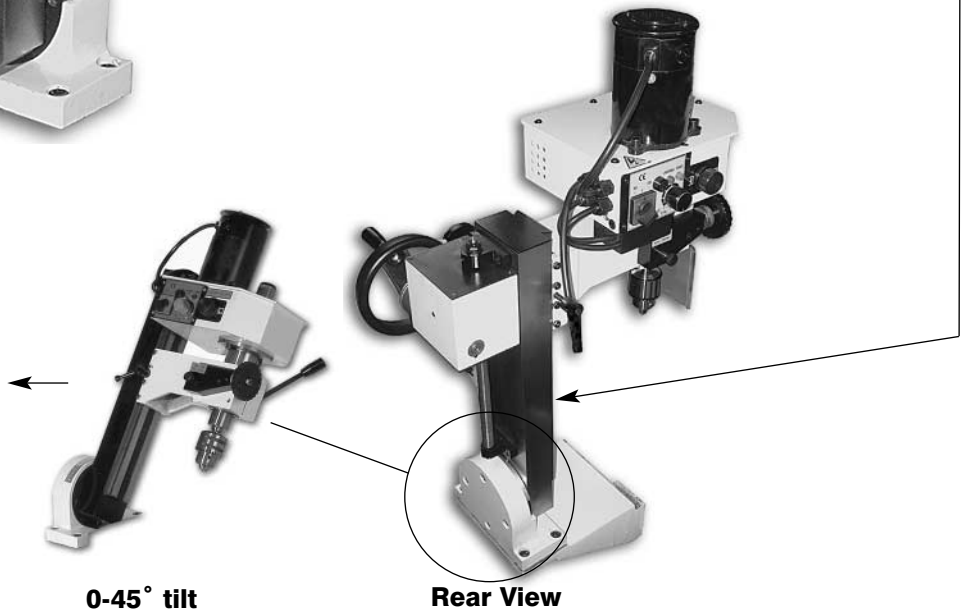
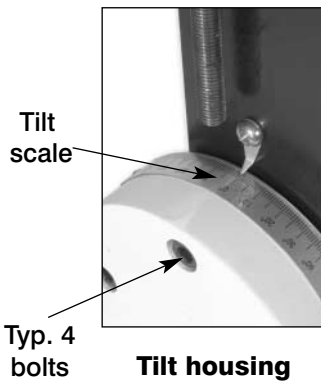
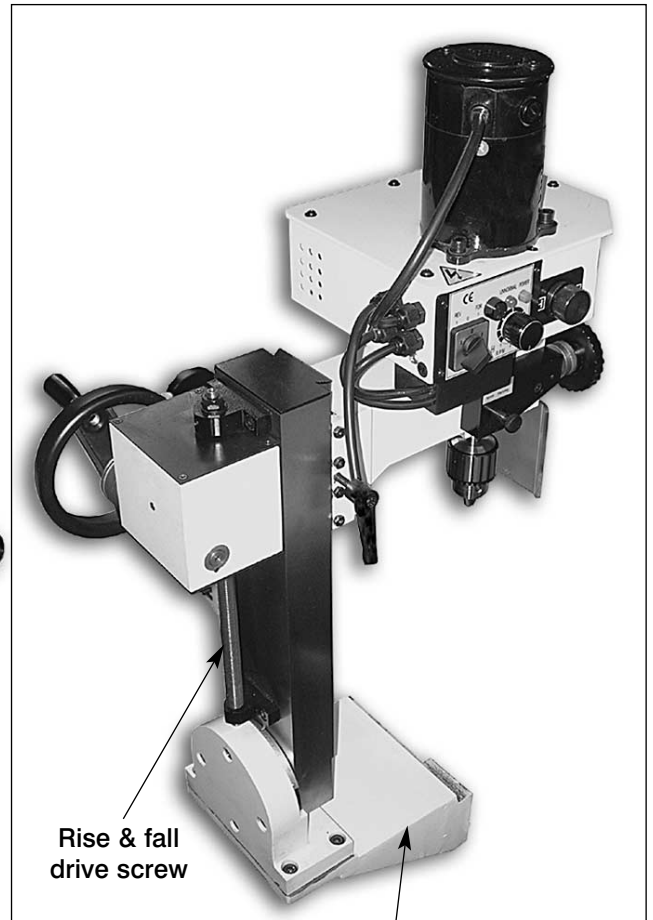
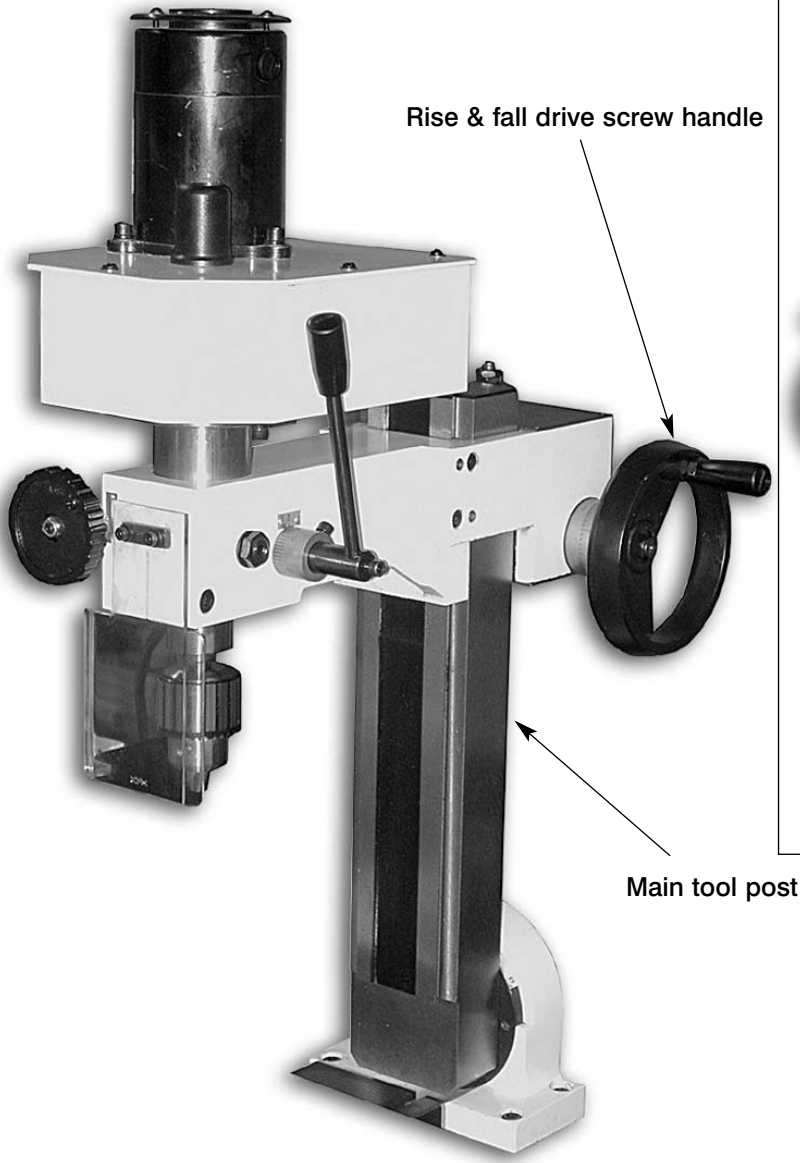

## PARTS IDENTIFICATION AND DESCRIPTION

<b>Gear change knob</b>	The gear change knob allows the selection of the high or low ratio of the gear train. The speed of the spindle is then governed by the speed control on the motor panel. (You may have to 'joggle' the chuck/tool to aid the meshing action).
<b>Motor</b>	A 220V d.c. motor rated at 150W.
<b>Feed Handle</b>	Lever handle that is used to drive the quill (and hence the chuck or the tool) up and down. The boss of the handle is fitted to the end of a 'splined' gear shaft. This 'splined' gear is, in turn, engaged in the rack cut into the quill body. There is a counter balance spring in the arbor and sleeve assembly, giving a more controlled 'feel' during drilling operations. It also retracts the quill when drilling is completed.
<b>Fine feed assembly</b>	The fine feed assembly floats around the splined gear shaft that drives the quill up and down. When the action of the fine feed mechanism is required; pulling out 'engage' knob of the fine feed control meshes the gearing (you may have to 'joggle' the feed handle to aid the meshing action) between the splined shaft and the fine feed control shaft; this enables the spindle to be driven by the fine feed control wheel with greater precision. Behind the boss of the fine feed control wheel handle is a graduated ring (thimble) so that the movement of the quill can be measured. The thimble is held to the drive shaft by friction, and can be pre-positioned to establish a predetermined start or stop dimension.
<b>Motor control panel</b>	<p><b><u>Power On LED</u></b> Green LED that indicates that power is available to the motor. i.e. mains is applied, fuse is intact and the Emergency stop switch is not activated.</p> <p><b><u>Fault LED (marked UNNORMAL)</u></b> Amber LED that indicates that there is a fault or an incorrect control sequence. i.e. the chuck guard interlock has been activated or the speed control is activated without forward or reverse direction being selected. The Motor will not run if the fault LED is illuminated. If the safety interlock is activated, the safety interlock will remain in force until the interlock is reset and the start sequence re-initiated.</p> <p><b><u>Fuse Cap</u></b> Access cap for the 20mm fuse cartridge (1 Amp 250V) Speed Control Knob Round raised ridge knob connected to the circuit that controls the spindle speed (100-1000 rpm or 100-2000 depending upon the gearbox selection).</p> <p><b><u>Forward /Off/Reverse Switch</u></b> Three position switch that controls the direction of rotation of the spindle. Forward indicates that the spindle is turning clockwise (looking down from above, reverse, the spindle is turning anticlockwise. The centre OFF position inhibits the spindle from turning in either direction, under motor drive.</p>

# MACHINE ILLUSTRATION OF THE MILL

Motor control panel

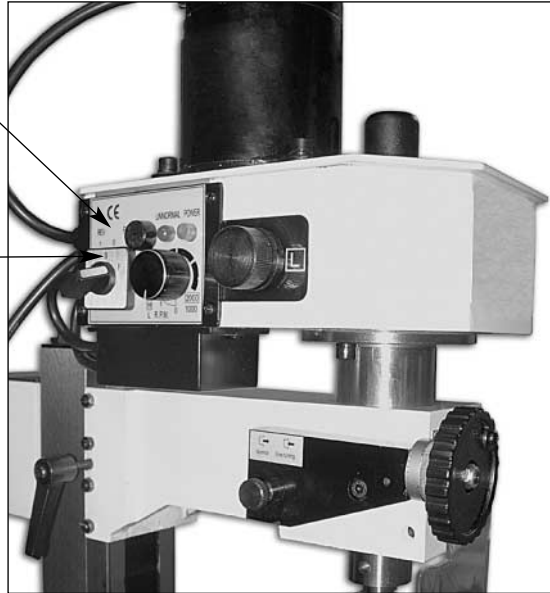

Fuse cap

Fault LED

Power on LED



Forward /Off/Reverse switch

Speed control knob

## PARTS IDENTIFICATION AND DESCRIPTION

**Quill hold pocket** The size of the machine precludes any 'fancy' locking mechanism for the quill. There is a blind pocket on the spindle that accepts the tommy bar supplied in the tool kit, to enable the spindle to be held in position whilst the draw bar is loosened.

**Draw bar cover** A moulded plastic cover that clips into the top of the Motor Gearbox assembly, to afford protection from the rotating top of the draw bar, when the quill is at the top of its travel.

**Draw bar (unseen)** This is a metal rod, threaded M10 at one end and with an 8mm squared shank and flange machined on the other. It is fitted through the spindle mandrel to hold the fitted tool/tooling hard into the No2 MT taper of the spindle shaft.

## MACHINE ILLUSTRATION OF THE MILL

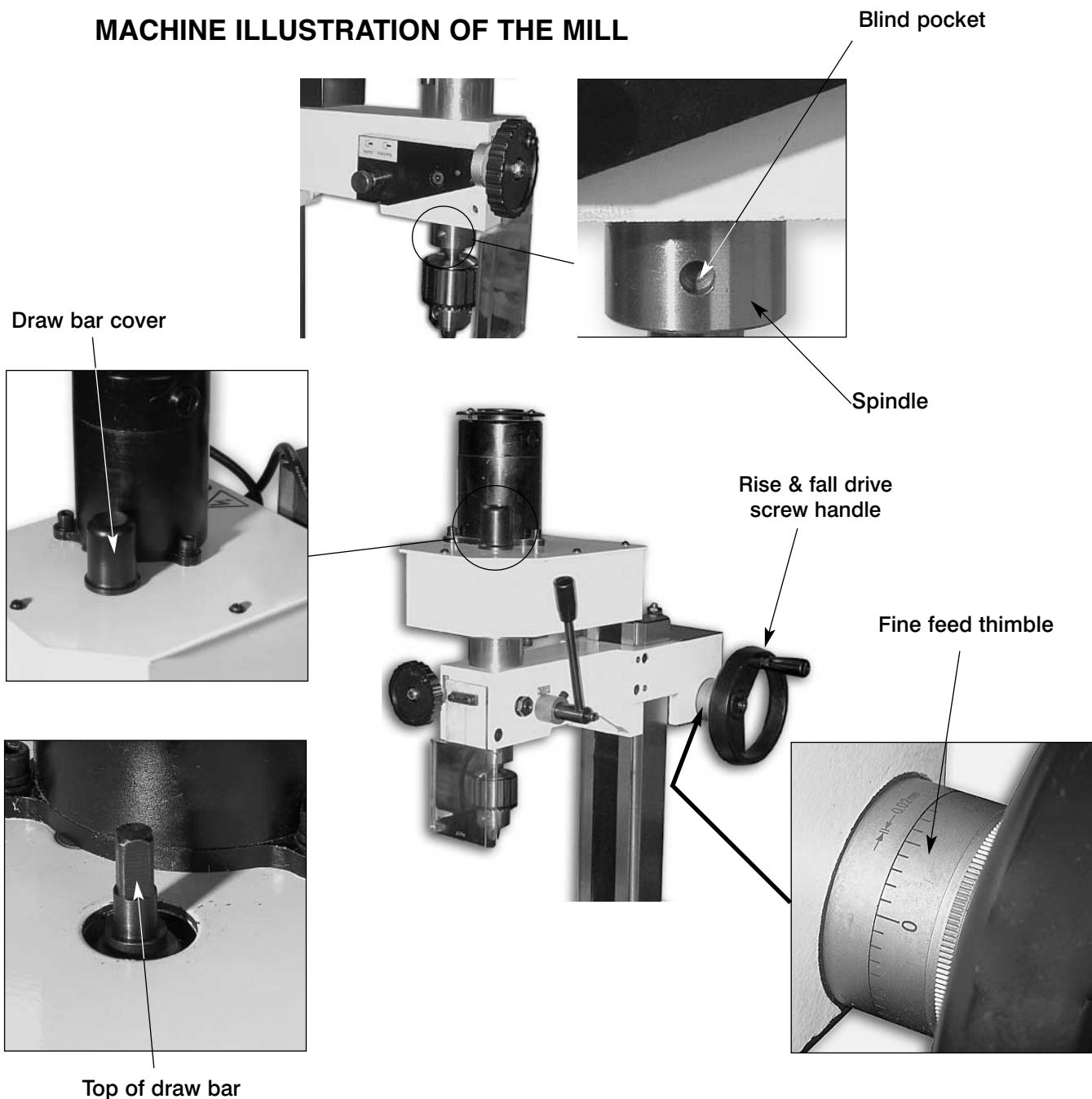

# MACHINE ILLUSTRATION OF THE MILL

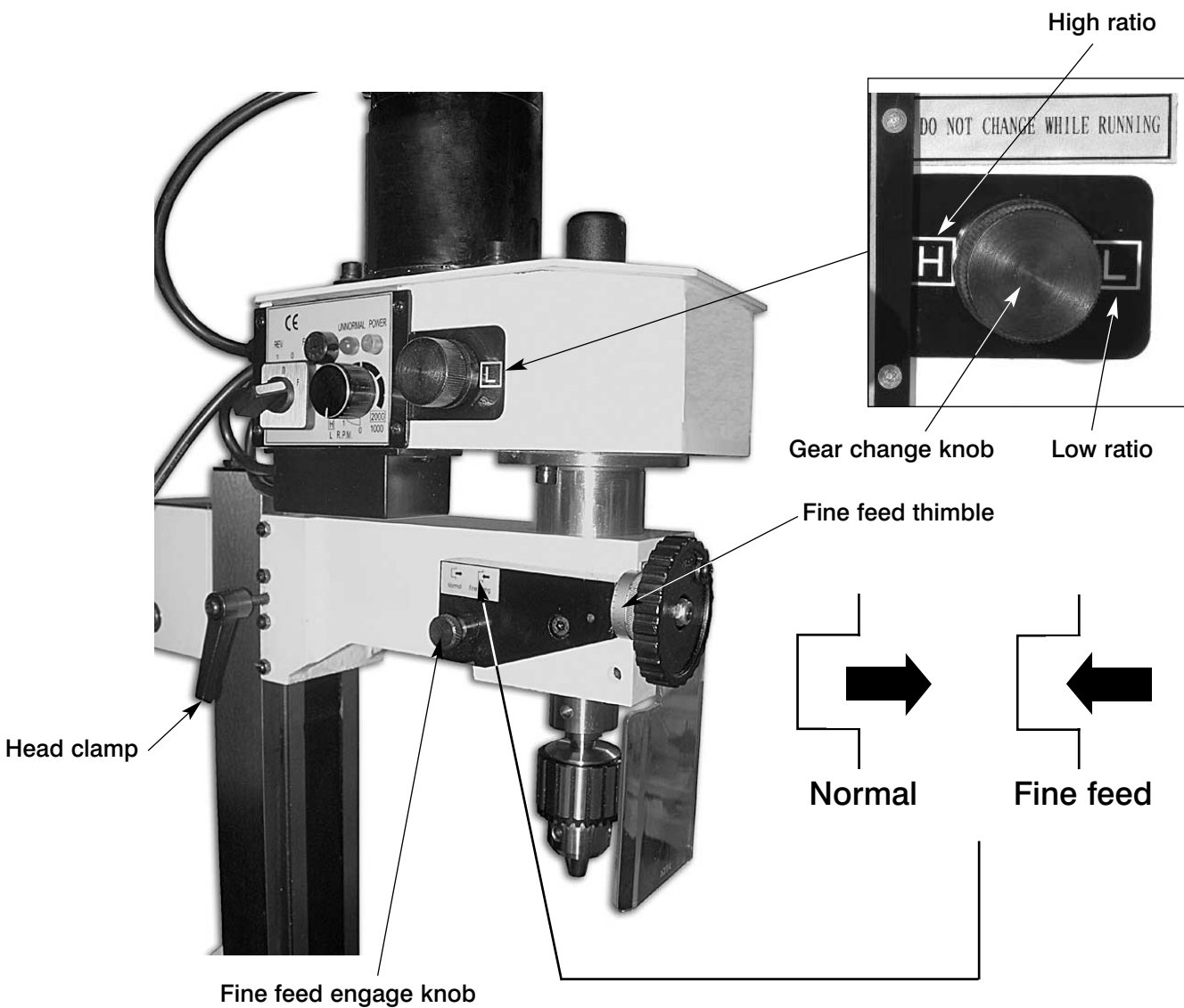
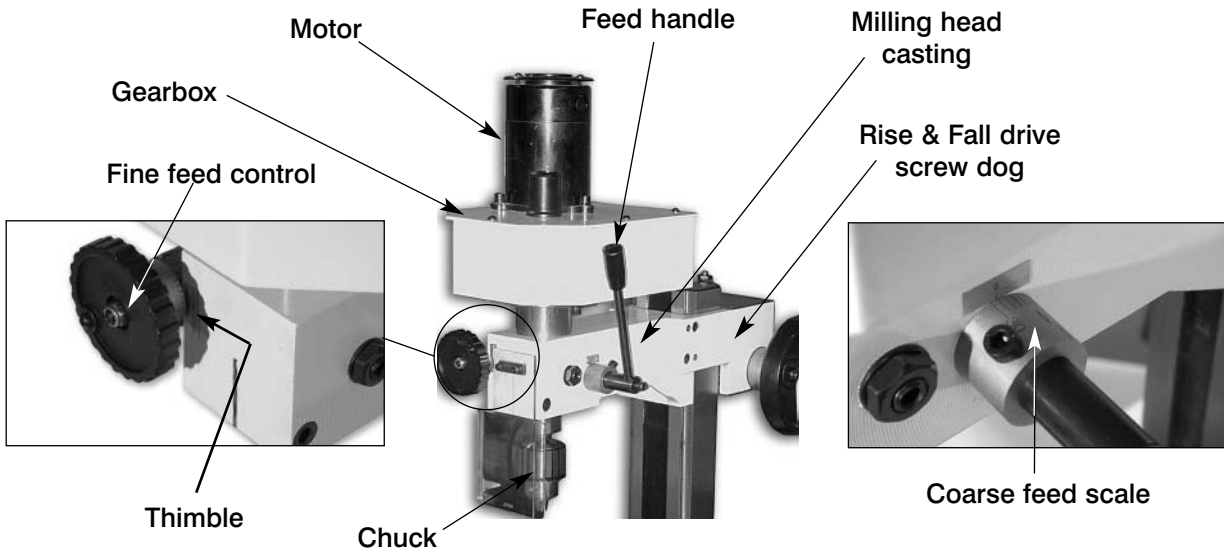

## GENERAL OPERATING INSTRUCTIONS



**Warning** Do not operate the mill in any function unless the head clamping lever is tightened.

### Tool Changing

**Note.** The taper socket in the spindle mandrel does not have a 'drive flat' and all tooling, including the drill chuck is secured and driven by the taper lock and the draw bar.

Make sure the power is switched off or better still remove the power from the machine.

Locate and put to hand the 8mm A/F spanner and the tommy bar. Remove the Draw Bar Cover.

Hold the quill immovable by inserting the tommy bar into the quill hold pocket and loosen the draw bar. Unscrew two or three turns and then strike sharply with a hammer (preferably a copper face, to prevent the head of the draw bar peining over) this will break the lock between the tool and the spindle tapers .

Unscrew the draw bar from the tool. **Ensure the tool is supported**, i.e. will not fall onto the workpiece/table et al. When it is free put the tool carefully aside, remove the draw bar, check the thread, check the taper and the thread of the new tool are clean and undamaged, introduce the new tool into the taper, re-insert the draw bar and screw into the top of the tool.

Screw in the draw bar finger tight. Hold the quill immovable and tighten with the spanner. **DO NOT OVERTIGHTEN.** Replace the draw bar cover.

Remove all tooling and reconnect the machine. Ensure the tool path is clear, switch on, and check that the tool is correctly seated, is running true etc. If all is O.K, proceed.

## GERERAL SAFETY POINTS

Milling (all cases)	Ensure the workpiece is securely clamped to the table.
Along the longitudinal Axis (X)	Ensure that the quill is locked in position before milling is commenced. Ensure the traverse slide lock is tightened.
Along the Traverse Axis (Y)	Ensure that the quill is locked in position before milling is commenced. Ensure the worktable lock is tightened.
Milling or Drilling Vertically (Z)	Ensure the traverse slide and the worktable locks are tightened.

## SETTING AND ADJUSTMENTS

### Milling Head adjustment

The Milling Head is mounted over a dovetail section. In order to maintain the 'tightness' of the fit; between the sloping surface of the component and its mating surface, on the left hand side, a gybe strip has been inserted. To adjust the gybe strip, use the supplied allen key and spanner, release the lock nuts and screw the gybe strip grub screws clockwise to compensate for any slackness or anti-clockwise to loosen the movement. Check, using the rise and fall drive feed handles, that the head moves smoothly, If not, repeat the adjustments until the movement is smooth and tight over the whole of the travel.



**Your Mill is a precision tool. In order to maintain this precision and prolong its useful life, it is advised that you follow the recommended daily and periodic maintenance tables printed below.**

## Daily and Periodic Maintenance

### Daily

---

Carry out a visual inspection. Repair any damage immediately. Minor damage to the beds should be taken out with an oilstone.

Move the worktable and the traverse feed back and forth by hand, check that the movement is smooth.

Spread a light film of oil over the worktable and the traverse slide bed.

Oil the end bearings of the drive shafts. Squirt oil onto the slide faces of mating components.

Exercise the components to ensure the oil is spread over both visible and obscure surfaces.

### Daily after-use

---

1. Clean all swarf and chips away from the machine bed, slide surfaces, and the tool post.
2. Exercise the slides and ensure no swarf etc., is lodged in the drive shaft tunnels. If you have been using a coolant make sure the machine is thoroughly dried off.
3. Check the tool, ensure it is usable the next time, if not re-sharpen or replace the tool tip.
4. Lightly oil spray all the machine beds and surfaces.
5. Clean and lightly oil any tools you may have been using (drill chucks, spanners, chuck keys etc), and put them away.
6. Switch off the power supply. Disconnect the plug.
7. Cover the machine over with a dust cloth.

### Weekly

---

1. Move the traverse slide fully back to give access to the tunnel, blow out to make sure all swarf is cleared away and heavily spray oil the tunnel, exercise the slide to work the oil into the drive thread and to lubricate the dog.
2. Spray oil the slide and the worktable bed, exercise the worktable to spread the oil to all surfaces, both hidden and visible.
3. Spray oil the underside of the machine onto the drive screws, exercise to ensure the oil is coating all components.
4. Clean and spray oil the rise and fall drive screw, exercise to ensure all parts are coated.
5. Check the movement of the worktable, the traverse slide and the head, check they are smooth and 'tight', if necessary reset the gybe strips until the movements are smooth and tight.
6. Wipe the quill outer sleeve clean and lightly oil, exercise the quill to spread the oil in the sleeve bushes.

### Monthly

---

- a) Give the motor a good 'blow through' to remove any dust, dirt etc,
- b) Check all the interlocks function correctly.

### Accessories

---

There are numerous accessories for the machine listed in the Axminster catalogue. Some are illustrated at the rear of this manual.

# MAINTENANCE OILING POINTS

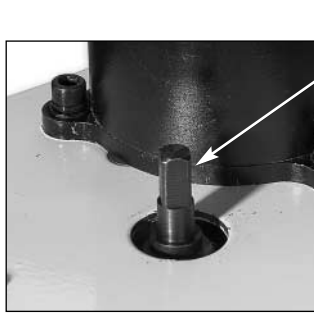

Top of draw bar cover removed for clarity

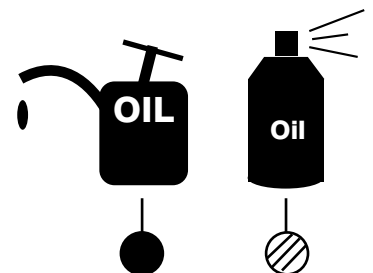
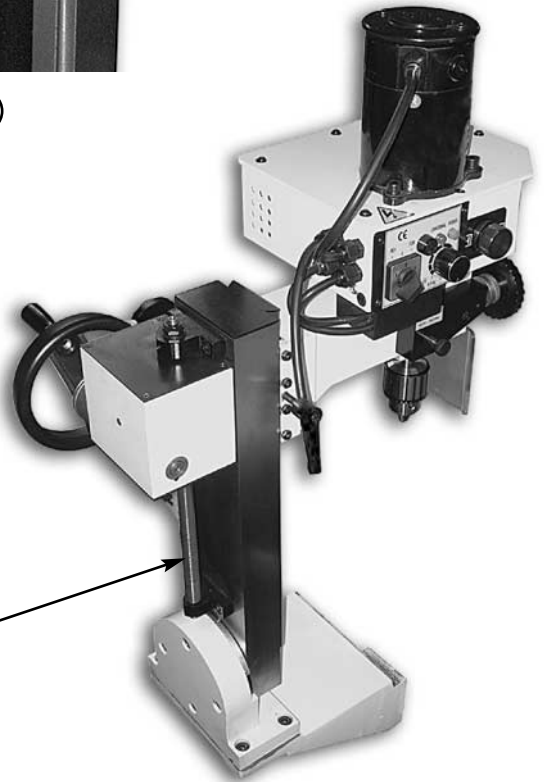
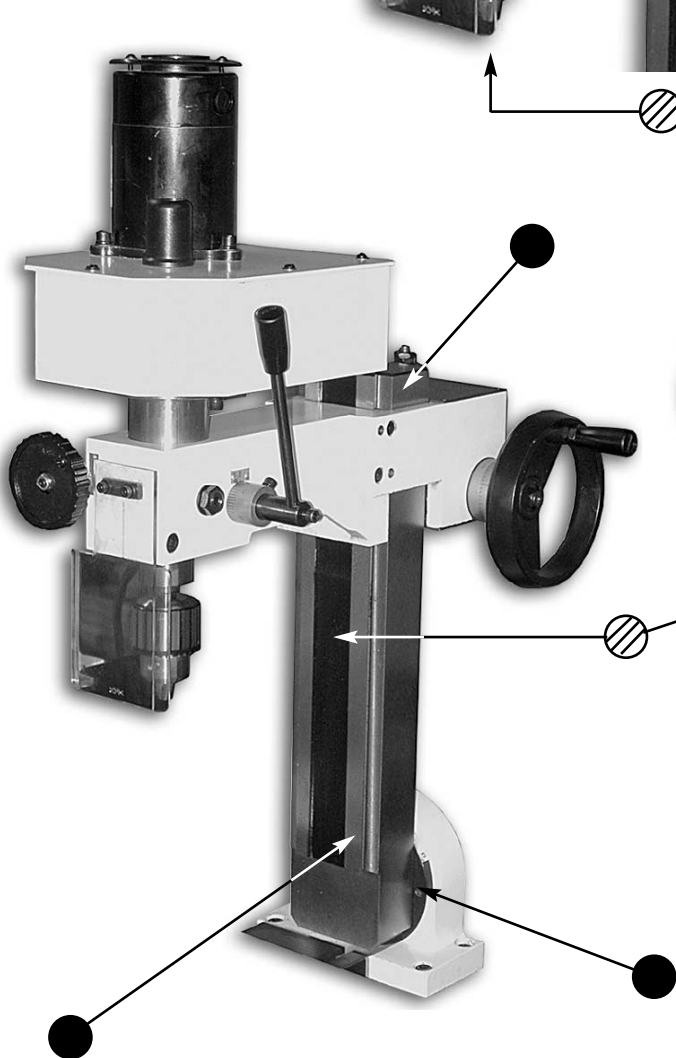
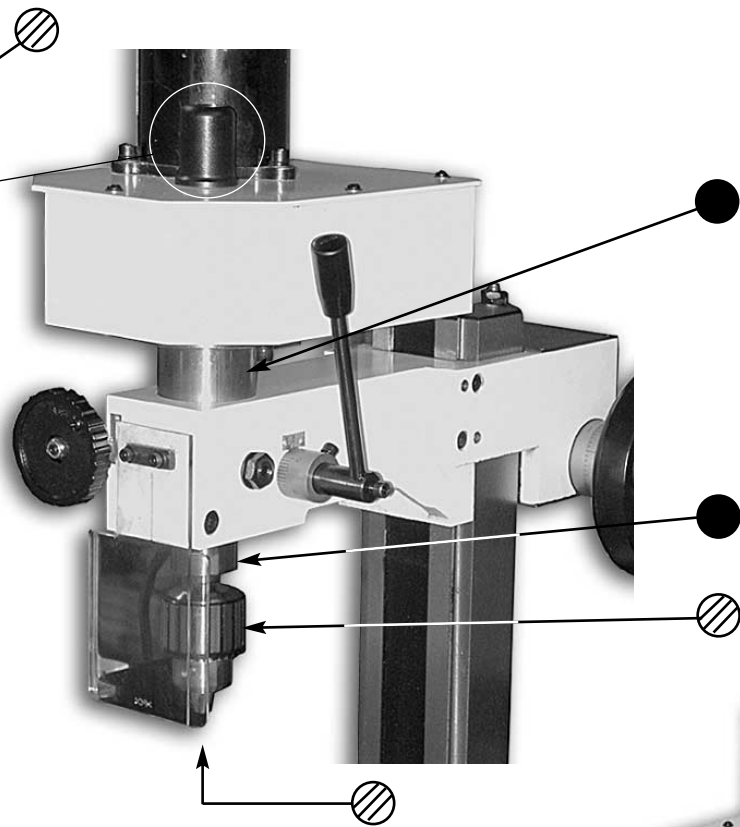

# MILL ACCESSORIES

## Rotary Milling Vice for Micro Mill 55mm

Code (100034)



## Axminster Micro Mill Collets

#2MT 6mm collet  
Code (100023)



#2MT 10mm collet  
Code (100024)



## 50mm Release Vice

Quick vice 50mm  
Code (100022)

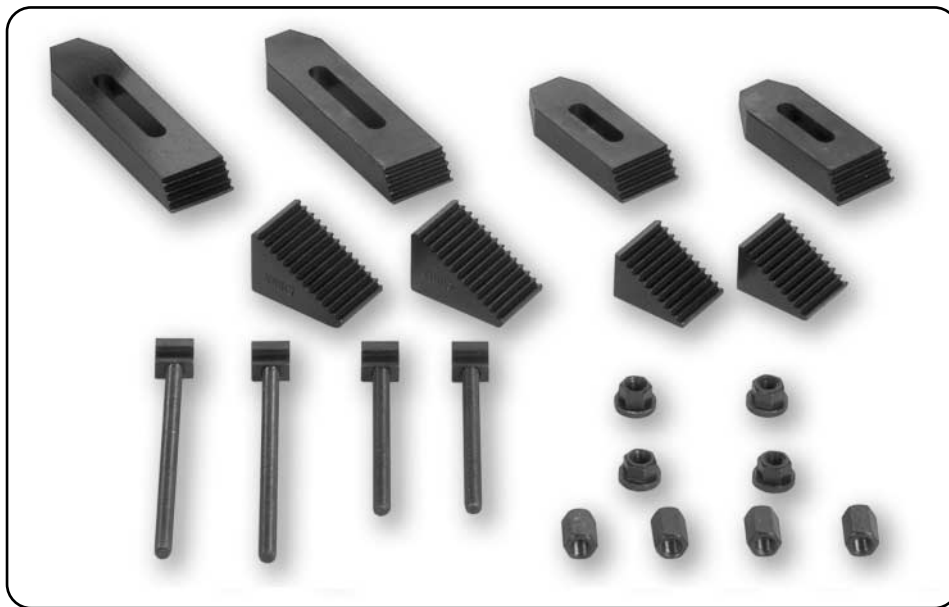

## Micro Mill Clamping Kit

Clamping kit  
Code (100033)

## Axminster Bull Nose Slot Drills



Metric Screwed Shank Two Flute Bull Nose Slot Drills

Code	Description
610170	Bull Nose Slot Drill 3mm
610171	Bull Nose Slot Drill 4mm
610172	Bull Nose Slot Drill 6mm
610173	Bull Nose Slot Drill 8mm
610168	Bull Nose Slot Drill 10mm

## Axminster HSS End Mills



Metric Screwed Shank Three Flute End Mills.

Code	Description
610177	3mm End Mill
610178	4mm End Mill
610179	6mm End Mill
610180	8mm End Mill
610174	10mm End Mill

## Axminster HSS Slot Drills



Metric Screwed Shank Two Flute Slot Drills.

Code	Description
610184	Slot Drill 3mm
610185	Slot Drill 4mm
610186	Slot Drill 6mm
610187	Slot Drill 8mm
610181	Slot Drill 10mm

# PARTS BREAKDOWN FOR THE MILL

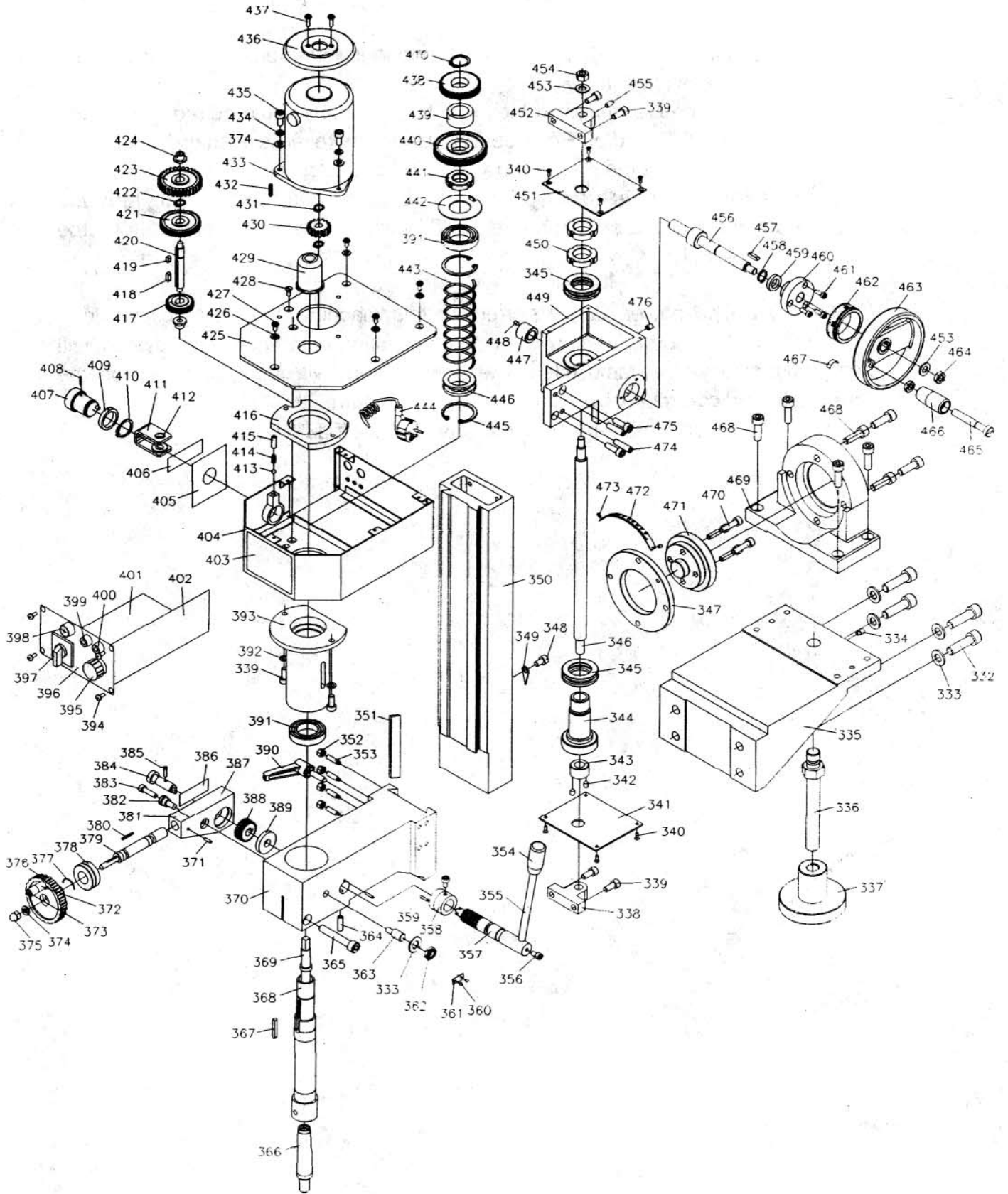

## PARTS LIST FOR THE MILL

NO	Description	Q' TY	NO	Description	Q' TY
332	Cap screw M10*35	4	362	Nut M10	1
333	Washer 10	5	363	Adjust screw	1
334	Set screw M6*10	1	364	Cap screw M6*20	1
335	Angle support plate	1	365	Cap screw M8*50	1
336	Support bolt	1	366	B12 taper shank	1
337	Angle support flange	1	367	Key 4*28	1
338	Under support	1	368	Spindle	1
339	Cap screw M6*14	6	369	Lock bolt	1
340	Screw M3*8	8	370	Spindle seat	1
341	Under plate	1	371	Round pin A3*18	1
342	Set screw M5*8	2	372	Rotate small handle	1
343	Nut	1	373	Handle screw	1
344	Big bevel wheel	1	374	Washer 6	4
345	Thrust ball bearing 8105	2	375	Lock nut M6	1
346	Aplomb leadscrew	1	376	Handlewheel	1
347	Circle press plate	1	377	Spring	1
348	Phillips head screw M6*10	1	378	Dial	1
349	Finger	1	379	Worm shaft	1
350	Spindle guide	1	380	key 2*18	1
351	Wedge	1	381	Label	1
352	Nut M6	4	382	Joint orientation screw	1
353	Slotted screw M5*18	4	383	Cap screw M5*18	1
354	Long handle sleeve	1	384	Joint shaft	1
355	Handle shaft	1	385	Round pin B3*12	1
356	Cap screw M5*8	2	386	Joint label	1
357	Gear shaft	1	387	Worm seat	1
358	Dial display sleeve	1	388	Bevel wheel	1
359	Spring pin 3*12	2	389	Spacer	1

## PARTS LIST FOR THE MILL

360	Aluminium rivet 2*3	2	390	Handle	1
361	0 position label	1	391	Ball bearing 61905-2Z	2
392	Spring washer M6	2	423	Gear	1
393	Spindle sleeve	1	424	Bearing	2
394	Self set screw ST2.9*6.5	4	425	Up cover	1
395	Speed control switch	1	426	Washer 4	4
396	Switch label	1	427	Screw M4*8	4
397	For./Off/Rev. switch	1	428	Screw M4*6	1
398	Fuse box	1	429	Safety cover	1
399	Power light	1	430	Motor gear	1
400	Yellow light	1	431	Check ring 8	2
401	PC Board	1	432	Key 3*16	1
402	Electric box	1	433	DC Motor	1
403	Label	1	434	Spring washer 6	3
404	Gear box assembly	1	435	Cap screw M6*12	3
405	Change label	1	436	Motor protect cover	1
406	Warning label	1	437	Screw M4*12	2
407	Change knob	1	438	Spindle gear	1
408	Spring pin 2*12	1	439	Spacer	1
409	Spacer	1	440	Spindle gear	1
410	Check ring 20	2	441	Round nut M24*1.5	1
411	Fork	1	442	Washer 24	1
412	Flange bush	2	443	Compress spring	1
413	Steel ball 5	1	444	Power line	1
414	Compress spring	1	445	Check ring 38	2
415	Set Screw M6*5	1	446	Spring seat	1
416	Sleeve fix plate	1	447	Brass sleeve	1
417	Change gear	1	448	Set screw M4*6	1
418	Key 4*12	1	449	Gear Box	1
419	Key 4*8	1	450	Round nut M22*1.5	2
420	Shift gears shaft	1	451	Gear box up cover	1
421	Shift gear	1	452	Up support	1
422	Check ring 10	1	453	Washer 8	2

## PARTS LIST FOR THE MILL

NO	Description	Q' TY	NO	Description	Q' TY
454	Lock knut M8	1	466	Handle	1
455	Set screw M5*10	1	467	Spring	1
456	Bevel wheel	1	468	Cap screw M8*25	8
457	Key 4*16	1	469	Connect support	1
458	Check ring 12	1	470	Cap screw M6*25	4
459	Washer	1	471	Connect flange	1
460	Support flange	1	472	Angle ruler	1
461	Screw M4*12	3	473	Rivet 2*6	2
462	Dial	1	474	Taper pin 6*26	2
463	Handlewheel	1	475	Screw M6*20	2
464	Nut M8	2	476	Oil cup 6	1
465	Cap screw M8*55	1			

## NOTES



## NOTES



Please dispose of packaging for the product in a responsible manner. It is suitable for recycling. Help to protect the environment, take the packaging to the local recycling centre and place into the appropriate recycling bin.

### **Only for EU countries**



Do not dispose of electric tools together with household waste material. In observance of European Directive 2002/96/EC on waste electrical and electronic equipment and its implementation in accordance with national law, electric tools that have reached the end of their life must be collected separately and returned to an environmentally compatible recycling facility.