

SCANIA



SCANIA PARTS

PARTS FACT FILE



TABLE OF CONTENT

SCANIA SPARE PARTS	3	SCANIA DISC BRAKE	38
SCANIA SERVICE EXCHANGE RANGE	4	SCANIA DRUM BRAKE	40
SCANIA CYLINDER HEADS	6	SCANIA AIR DRYER FILTER	42
SCANIA PISTON & LINER KITS	8	SCANIA AIR SUSPENSION BELLOWS	44
SCANIA ENGINE OIL FILTER	10	SCANIA U-BOLT AND SPRING BOLT	46
SCANIA TURBO-CHARGER	12	SCANIA SHOCK ABSORBERS	48
SCANIA VG-TURBOCHARGER	14	SCANIA ALTERNATOR	50
SCANIA AIR FILTER	16	SCANIA STARTER MOTOR	52
SCANIA RADIATOR	18	SCANIA LIGHTING	54
SCANIA COOLANT HOSES	20	SCANIA BATTERIES	56
SCANIA BELT TRANSMISSION	22	SCANIA SPIRAL CABLES	58
SCANIA UNIT INJECTOR	24	SCANIA WINDSCREEN	60
SCANIA FUEL FILTER	26	SCANIA WIPER BLADES	62
SCANIA SILENCER	28	SCANIA CAB SUSPENSION	64
SCANIA CLUTCH	30	SCANIA CAB AIR FILTER	66
SCANIA TRANSMISSION OIL FILTER	32	SCANIA OIL	68
SCANIA BALL JOINT	34	SCANIA COOLANT	70
SCANIA STEERING CYLINDER	36		

SCANIA SPARE PARTS

The increasing competition in the transport sector means that our customers have to focus to a greater extent on overall operating costs, vehicle uptime and potential productivity, at the same time as meeting increasingly stringent environmental legislation. Fleet maintenance is increasingly growing in importance, as is the influence of the vehicle inspection sector.

Scania parts and our strong service organisation contribute to improving the operating economy of our customers and the uptime of their vehicles. With Scania as a supplier of services and spare parts, our customers can focus on their transport assignments instead of repairs and maintenance. Scania's spare parts have been developed to meet the most stringent requirements on function and quality, as well as service life and reliability.

In this publication, we explain why our customers should choose Scania Parts, which is primarily on the basis of technical quality. There are essential properties in Scania Parts that contribute to improving the operating economy of our customers.

FOUR CORE VALUES

Scania Parts are based on four core values: availability, professionalism, customer value and quality. These values demonstrate how we support our customers and their operations, thereby building trust and loyalty. In this publication, we have opted to focus on arguments promoting quality and professionalism.

Quality

Customers must feel secure in the knowledge that Scania Parts give them value for money. They need to be aware that Scania makes major investments in technical development and product testing to ensure service life and reliability.

Professionalism

Professional skills and experience of Scania's workshop personnel, combined with the high availability levels of Scania Parts, contribute to increasing the productivity and profit of their customer's businesses.

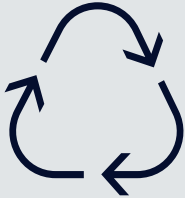

SCANIA SERVICE EXCHANGE RANGE

SUSTAINABILITY AND COST EFFECTIVENESS

The basis of a service exchange part is a worn-out part that is returned to the supplier as a core. The core then forms the raw material in the remanufacturing process. When the customer purchases a service exchange part, a deposit is paid that is refunded when the core is returned. The core must be in sufficiently good condition to enable its re-use. If the core is not in good condition then the reimbursement is reduced. The core must therefore be handled as valuable raw material when it is returned.

If the return criteria is met, the returned core will be cleaned, inspected and remanufactured to the same exacting standards as the new Scania part.

Compared with new spare parts, service exchange parts have several advantages:

- Competitive prices
- Reduced use of raw materials
- Reduced CO2 emissions
- Reduced energy consumption

This contributes to the 'circular economy' and sustainability.

CUSTOMER COMMUNICATION ON THE SERVICE EXCHANGE RANGE

Sometimes it is uneconomical to replace worn parts with brand new ones, especially in older vehicles, while trying to repair a broken part can take an unnecessarily long time at the workshop. That's why the Scania service exchange range is a cost effective way to quickly get the vehicle back on the road.

The Scania service exchange range gives access to a wide range of remanufactured components at competitive prices. The range maintains the same high quality as brand new spare parts and is covered by the same warranties, which creates a sense of security for the customer.

Service exchange parts have the following qualities:

They contribute to reduced environmental impact. Remanufactured parts fulfil the same function as new parts.

They are remanufactured using standardised industrial processes in accordance with the technical specifications.

A remanufactured part has the same warranty as a new part.



SCANIA CYLINDER HEADS

ABLE TO WITHSTAND THE TOUGHEST
OPERATING CONDITIONS

Scania cylinder heads are optimised to maximise engine performance and to ensure that the engine meets emission requirements throughout its service life.



CYLINDER HEAD FACTS

Material selection and precision

The cylinder head is subjected to high stresses in operation, including high pressures and temperatures that occur during combustion. Its components must also withstand stresses when the valves open and close several hundred million times during the service life of the cylinder head. The valves and valve seats must maintain sealing integrity, and the valve guides and valve stem seals must ensure lubrication. For this reason, it is important to use the right material and maintain high precision during manufacture.



WHAT WE HAVE DONE

1. Maintain shape

The design and material specifications of Scania cylinder heads are adapted to withstand the thermal and mechanical stresses that occur during combustion and under difficult operating conditions.

2. Maintain sealing integrity

Scania valves and valve seats are designed to minimise wear and maintain sealing integrity using carefully selected materials and high machining accuracy. The valve stem seal also maintains sealing integrity under the high pressures that occur in the exhaust and intake ports, while contributing to the lubrication between valve and valve guide.

3. Exchange cylinder heads

The cylinder head is included in the Scania service exchange system and is supplied complete with valves to facilitate assembly and minimise downtime. The exchange cylinder heads are always supplied with valves adapted for difficult operating conditions in order to ensure the service life of the engine and not compromise the performance of the head..

SCANIA PISTON & LINER KITS

LONG SERVICE LIFE WITH
OPTIMUM LUBRICATION

The Scania cylinder system provides the best possible performance and service life thanks to optimum lubrication. A new set of pistons and liners gives the engine new life.



CYLINDER SYSTEM FACTS

An interaction between various components

The cylinder system is subjected to high stresses. When the mixture of fuel and air is compressed and ignited, the load on the piston increases up to 18 tonnes. This takes place thousands of times per minute. Despite it being cooled, the temperature of the piston still increases to approximately 400 degrees. So it is important that cylinder liners, pistons and piston rings have the right properties and work perfectly together. Effective lubrication extends service life, and this is where the design and surface properties of the cylinder liner are crucial.

WHAT WE HAVE DONE

1. Long service life

The Scania cylinder system has a long service life thanks to meticulous material selection and optimal surface structure. The cylinder liner is plateau-honed to ensure low friction and optimum lubrication, which reduces oil consumption and increases service life. High-power engines use cylinder liners that have been honed and plasma-sprayed, which also reduces the risk of corrosion.

2. High performance

The standard steel piston has a geometrically optimised combustion chamber that provides high performance and low emissions. Aluminium pistons are used for lower-power engines. The designs provide high strength and are able to withstand extreme loads.

3. Tests and environmental impact

The Scania cylinder system has undergone extensive testing in vehicles and under different operating conditions, such as with varying loads and different oil and fuel grades. This is to ensure that the components meet environmental requirements in force and provide long service life even under tough operating conditions.

SCANIA ENGINE OIL FILTER

INSURANCE AGAINST ENGINE FAILURE

Scania oil filters have a high dirt absorption capacity, which is essential for following the recommended service intervals. Using Scania oil filters avoids unnecessary engine wear and minimises the risk of breakdown. This reduces maintenance costs and downtime.

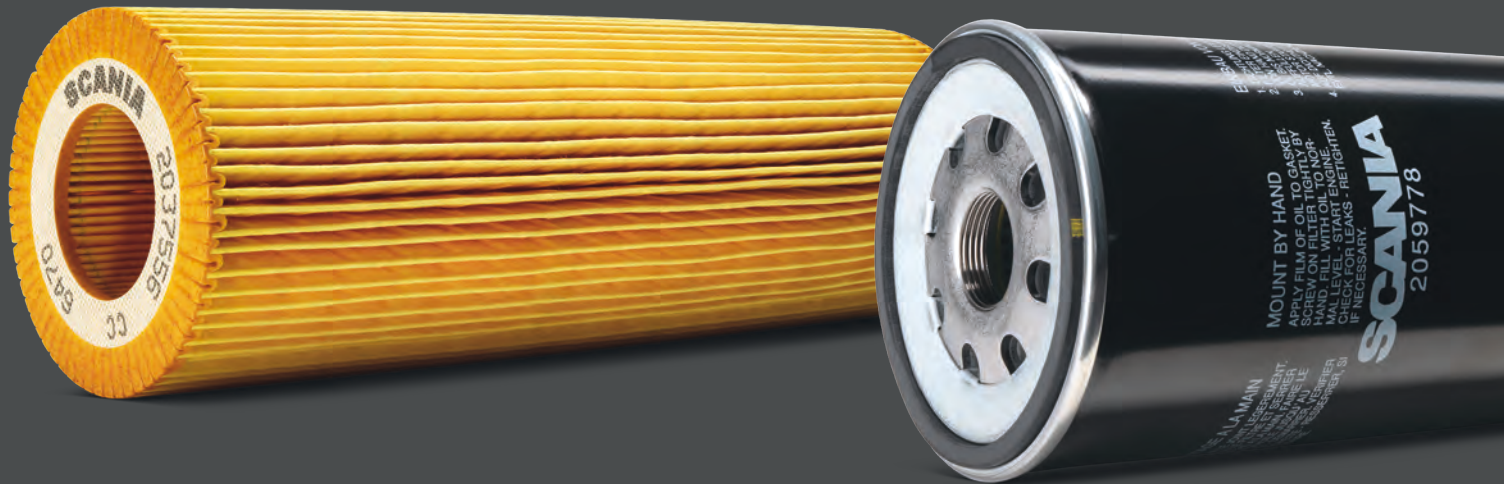

ENGINE OIL FILTER FACTS

The right filter and longer service life

The function of the oil filter is to collect impurities such as metal particles and soot, while letting through the right amount of oil to lubricate and cool the engine components.

Using an incorrectly specified oil filter can lead to:

- The filter becoming brittle and cracking due to unsuitable material
- Increased costs for maintenance and downtime
- Contaminated oil passing through, which can result in engine failure
- In a worst-case scenario, the filter becoming clogged can lead to engine failure

WHAT WE HAVE DONE

1. Tested for Scania engines

The Scania engine oil filter is tested for Scania oil pressures and flows. The filter is tested on all types of Scania engines, since the oil is degraded differently depending on engine type. For example, engines with EGR can make the oil acidic. For this reason, Scania carries out tests using acidic oil to ensure that the filter can withstand this stress.

2. The right material in the filter medium

The filter medium is made from synthetic and cellulose fibres to provide optimum resistance against degraded oil. Using the right material avoids the filter becoming brittle and cracking, which results in reduced wear and reduced risk of engine failure.

3. Withstands high pressures

The Scania engine oil filter has high mechanical stability and temperature resistance. This means it can withstand high pressures which is particularly important in modern lubrication systems.





SCANIA TURBO- CHARGER

AN INVESTMENT
IN ECONOMY AND
RELIABILITY

Scania turbochargers are designed and thoroughly tested for Scania engines. Their build and performance ensure that they deliver optimum output when required.



TURBOCHARGER FACTS

Low fuel consumption maintained

The turbine shaft in a turbocharger rotates at up to 130 000 rpm, with very tight tolerances between turbine blades and housing. Fuel consumption increases if the clearance is too great. Too little clearance can cause the blades to come into contact with the housing. This can cause extensive damage, reduce efficiency and lead to oil entering the combustion chamber, which can result in engine failure.

WHAT WE HAVE DONE

1. Advanced balancing

Scania turbochargers are manufactured with high precision. The balancing of the turbine wheel and compressor impeller, as well as the turbine shaft, is a process involving tight tolerances. Scania turbochargers are developed and tested for the various engines in the Scania range. Everything possible to provide optimum performance and the lowest possible emissions.

2. Maintain sealing integrity

Very high pressures are generated at the turbine outlet during exhaust braking. Scania turbochargers have been developed to withstand this pressure and to minimise exhaust gas leakage (blow-by) during exhaust braking, which results in minimal oil leakage via the crankcase ventilation.



SCANIA VG-TURBO- CHARGER

OPTIMISED OUTPUT AND
ENVIRONMENTAL PERFOR-
MANCE

The Scania turbocharger with variable geometry (VG) has been developed to meet stringent emission requirements, while at the same time providing good performance directly from low rotational speeds.



VG-TURBOCHARGER FACTS

High performance and low environmental impact

Today's diesel engines have to meet increasingly stringent emission requirements. The turbocharger with variable geometry (VG) is a sophisticated solution that continuously adjusts the intake area to the turbine. This is achieved electronically by attaching a control unit to the turbocharger. This provides a wider range of usable rotational speed compared with turbochargers with a fixed turbine geometry. The VG turbocharger is able to meet stringent emission requirements while provide good performance at both low and high rotational speeds.

WHAT WE HAVE DONE

1. Improved performance

The Scania VG turbocharger has been developed to meet stringent emission requirements while maintaining performance. The VG turbocharger provides improved performance over the whole speed range without increasing environmental impact.

2. Power from low rotational speeds

The Scania VG turbocharger quickly and efficiently varies the turbo effect regardless of engine speed. This provides ample power directly from low rotational speeds and optimal fuel consumption at high rotational speeds.

SCANIA AIR FILTER

CLEAN AIR REDUCES COSTS

Scania air filters supply the engine with clean air, efficiently cleaning the air to the engine by more than 99.9%. This results in good fuel economy and a long engine service life. Using Scania air filters reduces downtime and maintenance costs, it also extends engine servicelife and improves performance.



AIR FILTER FACTS

Handles large amounts of air

Today's trucks use approximately 36 cubic metres of air per minute for combustion.

Regardless of environment and operation, the function of the air filter is to supply clean air in order to extend engine service life. An air filter must never be cleaned since this carries a high risk of causing damage that cannot be detected.

Using defective filters leads to:

- Abnormal wear of parts such as slide bearings, pistons, cylinder liners and turbochargers.
- Increased repair costs.
- Lower engine power.
- Abnormally high fuel consumption

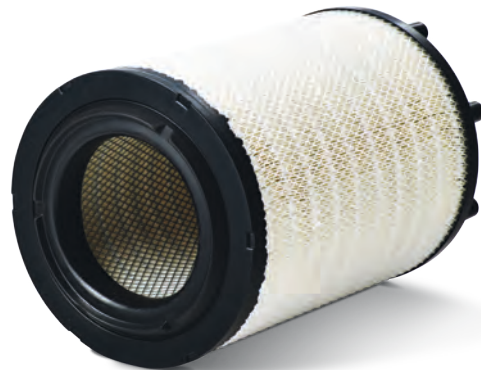

WHAT WE HAVE DONE

1. Developed for Scania vehicles

The Scania air filter is unique and developed especially for Scania vehicles. Our testing ensures the best possible performance. Patented seals provide protection so that no uncleaned air can damage the engine.

2. High filtration capacity and low pressure drop

Scania's air filters are optimised to ensure low pressure drop. This means that less power is used to draw air into the engine, which results in lower fuel consumption. High filtration capacity also means longer service intervals.

3. The precise fit seals

Even the best filter cannot work without fully sealing against the filter housing. Scania has carefully adjusted the dimensions and tolerances of the filter housing, filter cover and filter in order to achieve a precise fit.

SCANIA RADIATOR

MAXIMUM ENGINE
PERFORMANCE

Scania radiators are designed to withstand the tough thermal stresses they are exposed to and to maintain low fuel consumption and provide the best possible engine performance.

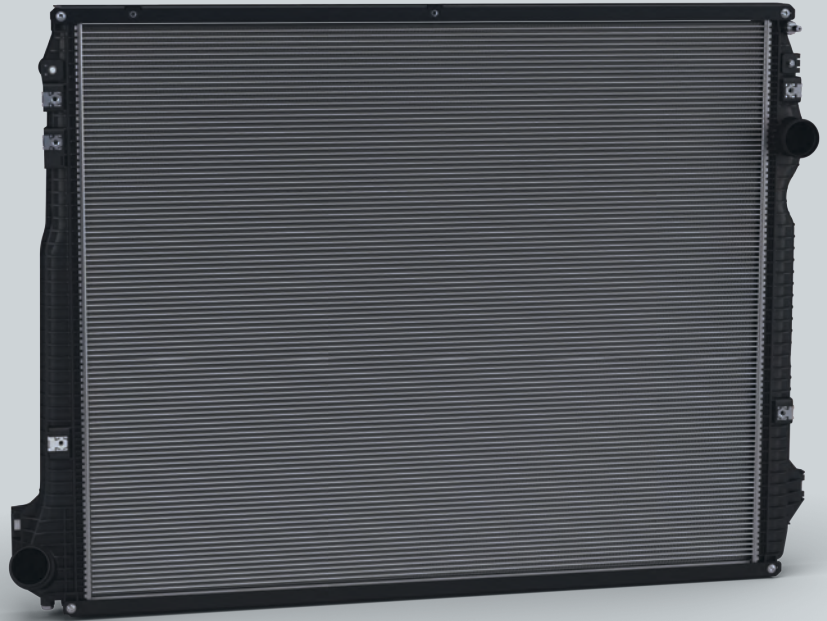

RADIATOR FACTS

Optimum operating temperature

New emission requirements place increasing demands on radiator performance. Today's engines must be driven at a high temperature to meet the stringent treatment requirements.

Powerful engines place high demands on the cooling system.

The engine has to work at the correct operating temperature to be able to deliver maximum output. The coolant also has to maintain the right temperature to ensure long service life for cooling system components and good operating economy. In extreme conditions, there is a risk of the engine overheating if the radiator is not working optimally. If the radiator does not cool sufficiently then damage may occur such as defective cylinder head cover gasket, damaged valves or pistons, cracked engine block and cracked cooling hoses.

WHAT WE HAVE DONE

1. Maximum cooling output

Scania radiators have been developed to provide maximum cooling, regardless of the operating conditions or climate. A condition for optimum performance is correct coolant temperature for engine, gearbox and retarder. Cooling output affects fuel economy and engine service life. A efficient radiator reduces the use of the fan, which contributes to lower fuel consumption. Scania has developed a larger radiator as well as new pipes and vanes to further increase the cooling output.

2. Material selection

The material selection in the radiator is very important for handling the temperature load it is exposed to. The material selection also determines how efficiently the radiator core cools the engine and extends the service life of the radiator. Incorrect specification of plastic material can result in cracks forming. The thermal strength has been further improved by moving the position of the outlet to as low as possible, which improves the flow and reduces stress.

3. Thorough tests

Scania performs extensive testing, including engine tests, long-term tests and field tests. The radiators are tested under actual operating conditions, which are difficult to simulate in a test cell. The tests ensure quality and performance.

SCANIA COOLANT HOSES

DURABILITY AND FIT

Scania coolant hoses are designed for the optimal functionality of the cooling system, even at high temperatures and pressures.



COOLANT HOSE FACTS

High stresses

The coolant hoses transport the fluid in the cooling system. The hoses are subject to high stresses since they are fitted in a vulnerable environment where they are exposed to high temperatures and pressures. It is therefore particularly important that the connections are designed to prevent leaks, which places considerable demands on the tolerance for various wall thicknesses in the hoses. The hoses must also be able to withstand the aggressive properties of the coolant.



WHAT WE HAVE DONE

1. Correct fit

Scania coolant hoses provide optimal function throughout the cooling system. The hose attachments are carefully designed to have a precise fit reducing the risk of possible leakage when the hoses are exposed to coolant at high temperatures and pressures.

2. Correct material

Material selection is important so that the hoses can withstand the high stresses. Scania coolant hoses are made of materials able to withstand high pressures and high temperatures, as well as aggressive coolant.

3. Thoroughly tested

Scania coolant hoses have been developed to withstand the stresses to which they are subjected, while maintaining performance and long service life.

SCANIA BELT TRANSMISSION

LONG SERVICE LIFE AND OPTIMUM TORQUE TRANSFER

Scania belt transmission is thoroughly tested for long service life and to providein efficient drive to the engine's peripheral systems. This leads to more secure transport assignments, with fewer unwanted stoppages.



BELT TRANSMISSION FACTS

An interaction between various components

The belt transmission drives the water pump, the alternator, the AC compressor and, in some cases, the engine fan as well. The idler roller and belt tensioner are important for maintaining the correct pretension in the circuit and for providing optimal torque transfer. Vibration and noise must also be minimised.



WHAT WE HAVE DONE

1. Continuous improvements

The idler roller in the circuit is subjected to high forces. To be able to meet current demands on service life, Scania has implemented continuous improvement and has developed an idler roller made of durable material with a double row of ball bearings and improved lubrication.

2. Correct pretension means long service life

The pretension in the belt circuit is affected by all interacting components, but primarily by the quality of the drive belt and belt tensioner. The drive belt must be of the correct length and rigidity for the belt circuit components to operate optimally and last a long time.

3. Preventive replacements

Scania recommends inspection of the belt transmission at regular intervals together with the alternator, and replacement as a preventive measure. Thereby reducing the risk of breaking down at the roadside.



SCANIA UNIT INJECTOR

HIGH ENGINE PERFORMANCE
THROUGHOUT THE ENTIRE SERVICE LIFE

Scania unit injectors are designed to provide the best possible performance and reliability, with the lowest possible fuel consumption and environmental impact.



UNIT INJECTOR FACTS

Supply the combustion chamber with fuel

The unit injector has a great influence on engine output, torque and fuel consumption. The function of the unit injector is to supply the combustion chamber with the right amount of fuel at the right pressure. The diffuser nozzles differ from unit injector to unit injector. Even though to the eye they look similar, they often differ in terms of materials and heat treatment. The wrong unit injectors can result in the engine not delivering the promised performance.

WHAT WE HAVE DONE

1. Service life

Scania unit injectors have an optimised service life by using the right surface treatment and thickness for the piston in the unit injector.

2. Lower fuel consumption

The unit injector has been developed to provide the lowest possible fuel consumption, which results in improved operating economy as well as reduced environmental impact.



SCANIA FUEL FILTER

CLEAN FUEL TO THE ENGINE

Scania fuel filters are designed to meet Scania's uniquely stringent performance requirements. They have been developed and tested for different fuel systems, fuel qualities and operating conditions.



FUEL FILTER FACTS

An efficient fuel filter means security

The fuel filter is a central component in modern, heavy trucks. The high precision in today's fuel injection systems means that the components must be protected against contaminants. The combination of high pressure and extremely small tolerances also means that very small particles, which are not filtered out, can cause serious damage. The fuel filter must therefore have the correct degree of filtration and be adapted for the fuel used, as well as for the pressures and flows that occur in each type of engine. If the fuel filter is not working or is of the wrong specification, the engine may sustain serious damage.

WHAT WE HAVE DONE

1. Adapted for different fuel systems

Scania fuel filters have been developed and tested for a wide range of operating conditions. Each fuel system has its own combination of flow, pressure and temperature, and Scania fuel filters are adapted accordingly. The requirements for service life, degree of filtration, water separation, fuel compatibility and vibration resistance are unique to each Scania engine.

2. Tested for different fuels

Scania prefilters and main filters have been developed and tested to balance each other for optimal performance. The filters are tested together with other injection components and aftertreatment systems, and are adapted to suit different fuel qualities. In certain markets, Scania uses prefilters to be able to handle fuels containing high volumes of contaminants and with a high water content.

SCANIA SILENCER

LOW FUEL CONSUMPTION
MAINTAINED

Scania silencers not only ensure acoustic comfort in the cab and surrounding environment, they also ensure that the vehicle achieves low fuel consumption and correct emissions, as well as ensuring the service life of valves and turbocharger, for example.



SILENCER FACTS

More complex than it seems

Achieving optimal engine performance requires that all exhaust components interact. Many alternative silencers are designed without taking other components into account. If the exhaust system is not considered as a whole unit then there may be unwanted consequences, such as higher noise levels and emissions so that the vehicle does not meet legal requirements in force. Similarly, the service life of engine components may be reduced - such as valves and turbocharger. Changing to the wrong silencer may also lead to higher fuel consumption.

WHAT WE HAVE DONE

1. Improved operating economy

Scania silencers for Euro 6 contain catalytic converters and particle filters that are precisely adjusted for each engine and engine power rating. The balance between sound reduction and counterpressure in relation to other engine components has been optimised. Thanks to the fact that Scania has been able to ensure the right counterpressure in the system, fuel consumption has been reduced, while the service life of other interacting components has been increased.

2. Improved driver comfort and improved road safety

Scania silencers are carefully designed to provide as much noise reduction as possible. The low frequency noise from the engine, which can be tiring for the driver, has been halved compared with earlier silencers.

3. Thorough testing

Scania silencers undergo extensive testing in order to ensure their strength, function and performance throughout the service life of the product.



SCANIA CLUTCH

CONTROLLED TORQUE TRANSFER

The Scania clutch provides optimal control over torque transfer with maintained comfort throughout its entire service life.



CLUTCH FACTS

More than just torque transfer

Enormous force is transferred from the engine, via the gearbox, to the rear axle and then onto the road surface. Fitted in between them is the clutch, with its two friction surfaces, whose function is to set everything in motion. The function of a clutch is not just to transfer torque, it also acts as a damper, which minimises powertrain vibration. Each combination of engine and gearbox has its own unique torsion forces and vibration patterns. Only a perfectly adapted clutch system can ensure optimum control of torque transfer while maintaining comfort throughout its entire service life.

WHAT WE HAVE DONE

1. Adapted for Scania vehicles

Scania clutches are adapted for the complete range of Scania vehicle types. All subcomponents - from the smallest rivet to the strong diaphragm spring - are interconnected to form a system that delivers maximum torque with minimum vibration in the powertrain.

2. Extended service life

The wear surface for Scania clutch linings has been increased from 3.6 to 5 mm, and in combination with the latest generation of gearboxes, this increases their service life by up to 40%.

3. Clutch kits

Scania now supply clutch kits because we know that accessing and replacing a clutch is a labour intensive activity. By replacing the complete clutch unit the customer saves on workshop costs and benefits from increased vehicle uptime.

SCANIA TRANSMISSION OIL FILTER

PROTECTS THE GEARBOX AND CENTRAL GEAR

Scania transmission oil filters extend the service life of expensive and sensitive components in the gearbox and rear axle gear, while improving performance at the same time.

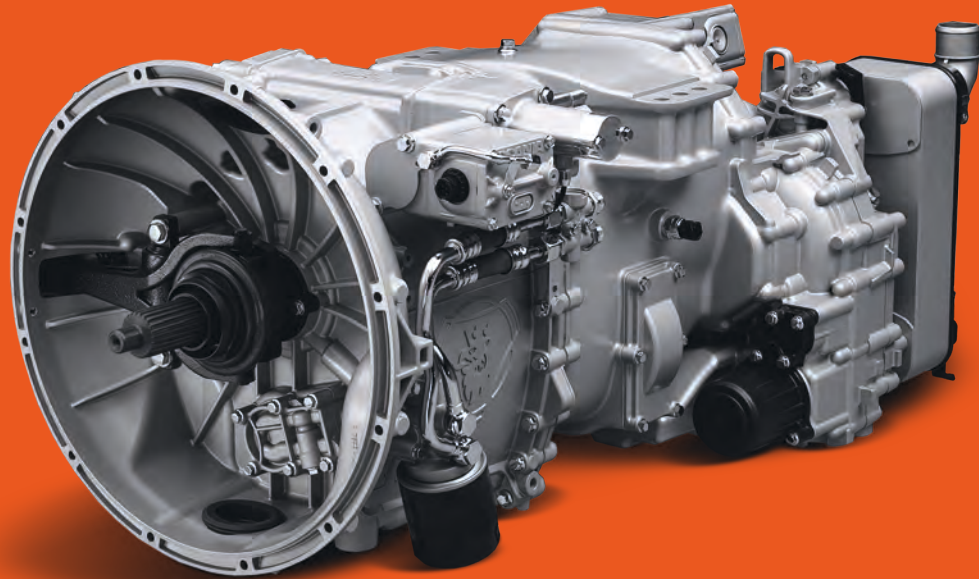

TRANSMISSION OIL FILTER FACTS

Oil filter that reduces gear wear

The function of the transmission oil filter is to remove metal particles from the oil, and to prevent unnecessary wear on gears and bearings in the gearbox and the central gear. Gears, crown wheels, pinions, bearings and synchromesh in the gearbox are subjected to extremely high surface pressures, and here the oil must fully protect against direct metal contact. The smallest particle that breaks the oil film considerably shortens the service life of the components. The filter must therefore be able to deal with very small particles, regardless of whether the oil is hot or cold, and it must be able to handle the pressure peaks that occur during cold starting.



WHAT WE HAVE DONE

1. Clean oil extends service life

The filter medium in Scania transmission oil filters is made of glass fibre, which filters out small particles more effectively than cellulose, for example, and it has a high capacity for binding dirt particles. This results in extremely clean oil, which extends service life, particularly for roller bearings in the gearbox and central gear.

2. Crucial protection for the central gear

The position of the central gear means that the oil filter is highly exposed to slush, gravel, sand and salt. To be able to handle tough operating environments, hot dip galvanised steel is used for the filter casing, which provides excellent corrosion protection.

3. Can withstand high temperatures

The development of gearboxes places increasing demands on the heat resistance of components. The oil filter gasket is therefore made from a heat resistant material. This reduces the risk of it deforming or stiffening, thus reducing the risk of oil leaks.

SCANIA BALL JOINT

MAINTAINED CONTROL AND
REDUCED VIBRATION

Scania ball joints have been developed to minimise vibration and tyre wear. Service life is extended by using an effective seal.

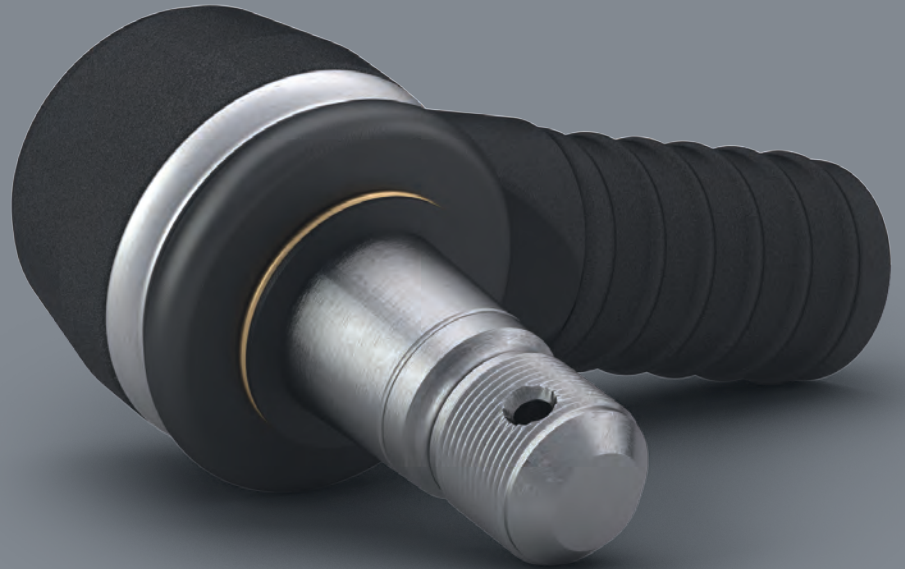

BALL JOINT FACTS

Perfectly adapted ball joints maintain safety

The steering system consists of many safety-critical components. All of them must fit together perfectly to maintain the function in this important system. The ball joint forms the transition to link arms and steering cylinders. If the ball joint fails then the steering capacity is lost. Quality varies between the different ball joints on the market, despite their similar appearance. The difference is on the inside. Optimally suited and fitted ball joints are a prerequisite for safe steering. A perfectly adjusted and aligned ball joint maintains steering capacity and minimises tyre wear.

WHAT WE HAVE DONE

1. Material selection

Scania ball joints are of the highest quality, and the materials are thoroughly tested in order to meet our stringent requirements. We have also developed a unique boot that provides maximum protection against dirt and gravel, and it ensures the longest service life and highest functionality possible.

2. Perfect hardening

Scania ball joints are hardened to precisely the right hardness. This is very significant since incorrectly hardened ball joints will be quickly worn out and can cause a loss of steering capacity.

3. Testing

We expose our ball joints to the toughest tests possible in order to ensure the highest quality. Everything possible to ensure that the ball joints meet Scania's stringent requirements for corrosion resistance, play, durability and service life.



SCANIA STEERING CYLINDER

THE SCANIA STEERING CYLINDER IS TESTED TO WORK WITH ADJACENT COMPONENTS TO PROVIDE GOOD DRIVING COMFORT AND STEERING CHARACTERISTICS.



STEERING CYLINDER FACTS

Increased steering capacity

The steering cylinder facilitates easy turning and increases manoeuvring ability at low speed. If it stops working then the vehicle's steering will soon feel heavy which may lead to increased over steer and impaired road safety.

WHAT WE HAVE DONE

1. Centring properties

Scania steering cylinders are developed to provide increased manoeuvrability in confined spaces and at low speed. They also help the vehicle to feel stable at high speed since they centre the axle on straight roads with very small steering deflection giving maximum driving comfort.

2. Driving experience

Scania steering cylinders have been developed to work optimally with the hydraulic pump and overpressure valves in all situations as well as to provide the best driving experience possible.

SCANIA DISC BRAKE

OPTIMISED SYSTEM WHERE SAFETY, QUALITY AND COMFORT HAVE HIGHEST PRIORITY

The Scania disc brake system has been developed for maximum safety. The components have been developed as individual parts in a complex system to ensure long service life and optimum performance in a vulnerable environment.



DISC BRAKE FACTS

Must be developed for tough operating environments

The brake system is the most important safety system in a vehicle.

An increased speed from 80-100 km/h means that the energy to be handled by the brake system increases by 56%. This places very high demands that the different components in the brake system work optimally so that safety is not put at risk. The brake disc must be able to withstand temperatures of up to 900 degrees.

The complete system consists of several component subsystems. If an original part in the system is replaced with a foreign part, the vehicle will no longer brake optimally.

WHAT WE HAVE DONE

1. Development and testing

For disc brakes, a Scania-patented alloy is used in the brake disc, as well as a unique specification for the friction material. The friction coefficient depends on the disc and the properties of the brake pad lining. The most important test of linings

and discs takes place in the brake dynamometer and on the vehicle. The system is tested both on the test track and on the public road network. The friction material and the composition of the disc are optimised continuously in connection with testing.

2. Optimal friction

The friction coefficient is a combination of the friction coefficients of the disc and the linings. We have optimised this coefficient over several years of development. Too high friction leads to the disc and lining wearing down unnecessarily quickly. Too low friction leads to the disc rusting, which leads to intensive shaking. By compressing the brake pad lining in the right way we have succeeded in creating an even heat load, which means that crack formation or disc failure is avoided, at the same time as ensuring brake comfort.

3. Environment

Scania protects the environment. In addition to our brake calliper being available as "Service Exchange", we use green linings - also known as "ABC brake pad linings" - which are totally free of asbestos, lead and cadmium.

SCANIA DRUM BRAKE

AN OPTIMISED SYSTEM WHERE
SAFETY AND QUALITY ARE TOP
PRIORITY

The Scania drum brake system has been developed for maximum safety. The components have been developed as individual parts in a complex system to ensure long service life and optimum performance in a vulnerable environment.

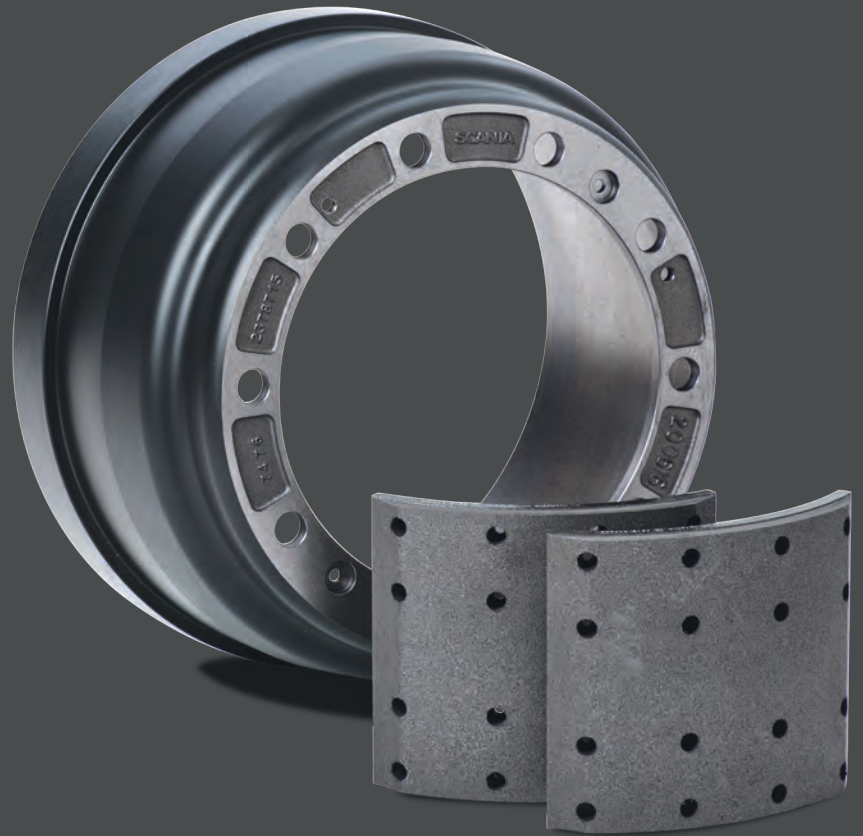

DRUM BRAKE FACTS

Focus on safety

The drum brake is robust and brilliantly simple when it comes to absorbing brake forces.

Drum brakes have a self-reinforcing property, which means that less external reinforcement is needed. However, the self-reinforcement is proportional to the friction coefficient. This means that it is very important to original shoes and drums to avoid pulling to the side or overloading the brakes. The heat load can become high since drum brakes are enclosed.

WHAT WE HAVE DONE

1. Safety

The Scania brake slack adjuster has an adjusting mechanism that controls the clearance between brake drum and brake shoes to a set distance, adapted for Scania drum brake geometries. This ensures safe braking effect each time the vehicle is braked throughout the entire service life.

2. Maintain shape

Scania brake drums have been developed for minimal wear and to counteract cracking, even in high temperatures. The material in the brake drum is dimensionally stable, providing consistent performance throughout the entire service life of the brake drum.

3. Tested

Scania brake shoes and brake linings have been designed and thoroughly tested in terms of shape and friction in order to prevent vibration and screeching.

SCANIA AIR DRYER FILTER

EFFECTIVE FILTRATION IN THE PNEUMATIC SYSTEM

Scania air dryer filters prevent up to 99.95 per cent of all particles from reaching the air processing system. This provides excellent protection for the pneumatic system. With stable function and high reliability, Scania air dryer filters ensure that service intervals are maintained.



AIR DRYER FILTER FACTS

Stops moisture and oil contamination

Engine oils contain an increasing amount of additives. When the oil is heated up, degradation particles are formed in the form of aerosols (tiny drops of oil). These are transported onward into the pneumatic system and can destroy seals in valves and other components. The function of the air dryer filter is therefore to separate out both oil and other foreign particles, as well as moisture from the air. If this fails to work then it may lead to costly downtime.

WHAT WE HAVE DONE

1. Correct desiccant volume

Scania air dryer filters contain more desiccant than many other air dryer filters on the market, thus ensuring a high drying capacity throughout the entire service life of the filter. This reduces the risk of corrosion damage and freezing damage to the vehicle components that use compressed air.

2. Effective oil separation

At the bottom of the air dryer filter is an oil separating filter that effectively absorbs harmful aerosols in the air. Something that further reduces wear on the vehicle components that use compressed air.

3. Thoroughly tested for Scania vehicles

Scania air dryer filters are developed especially for Scania vehicles. Extensive tests are carried out to ensure optimum performance of the air dryer filter under various operating conditions.

SCANIA AIR SUSPENSION BELLOWS

GREATEST POSSIBLE COMFORT

Scania air suspension bellows have been developed especially for each vehicle model in order to provide maximum driving comfort, service life, safety and correct axle weight display regardless of road conditions.



AIR BELLOWS FACTS

Suspension adapted for the application area

The air bellows contribute to improving the vehicle's overall comfort. Defective air bellows will quickly impair axle suspension and tyre wear, as well as increase vibration in the vehicle. This can be destructive for both driver and load. It is therefore important that all parts of the suspension are fully tested. Using the right damping avoids downtime costs, risk of accidents and damage to the load.

Incorrect axle weight display can result in heavy fines.

When the bellows need to be replaced, replacement with original bellows is recommended, thereby ensuring that the original vehicle specification is maintained and avoiding the risk of error during assembly.

WHAT WE HAVE DONE

1. Durability and strength

Scania air bellows are dimensioned and tested for a range of operating conditions and have well balanced characteristics. What is unique to Scania are the kinematics, with relatively large suspension travel. Great emphasis has been placed on maintaining bellows function, resulting in maximised service life.

2. Finely adjusted axle weight

Optimised height and load-carrying capacity are important for safe use of the suspension system at, for example, loading platforms (trucks) and boarding (buses).

The axle weight gauge is developed and well adapted for Scania bellows so that it shows the correct weight.

3. High quality materials

Scania uses high quality materials to ensure optimal protection against extremely high and low temperatures, ozone and sunshine. The corrosion resistance is best in class. The maximum ultimate strength is specially adapted to meet Scania's rigorous requirements.

SCANIA U-BOLT AND SPRING BOLT

UNIQUE SURFACE TREATMENT
ENSURES LONG SERVICE LIFE

Scania U-bolts and spring bolts have been developed to provide optimum suspension function together with other suspension components. A unique new surface treatment ensures longer service life and reduced operating costs.

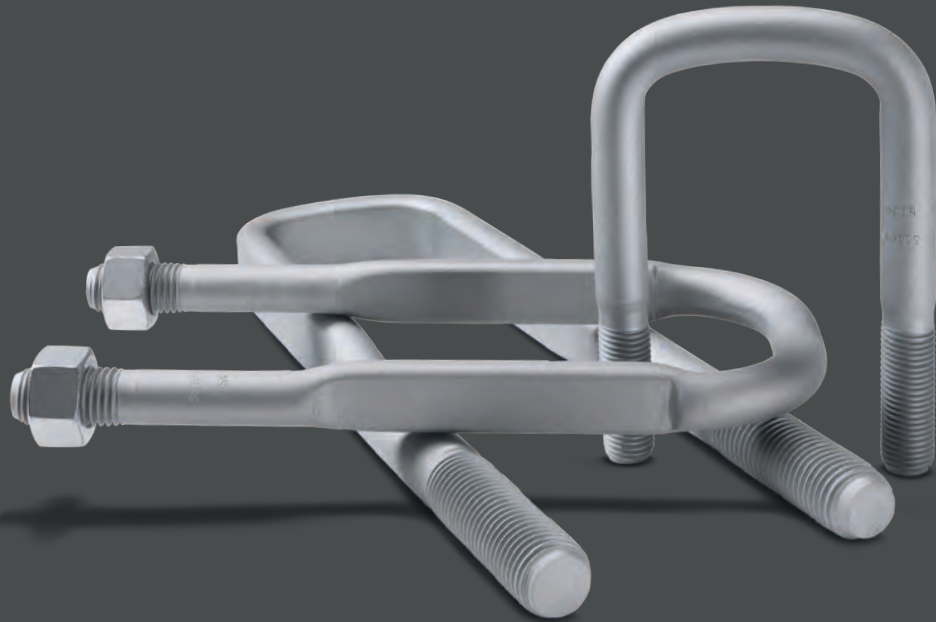

U-BOLT AND SPRING BOLT FACTS

Important parts of the suspension system

To hold axles and suspension packages in place, a few small and inconspicuous components are required, which are of major importance to safety. The U-bolts, which hold the entire spring package in place in the chassis, are subjected to high forces during suspension travel and therefore need to be of good quality and be tightened to the correct tightening torque. To prevent spring failure, it is important to follow the recommended intervals for spring bolt lubrication.



WHAT WE HAVE DONE

1. Unique surface treatment

The surface treatment of U-bolts and spring bolts is of great importance since these components are located in a very aggressive environment. Scania U-bolts and spring bolts are surface-treated using a new method (inorganic surface treatment with flake), which extends their service life. You can recognise the new Scania surface treatment because it is black for spring bolts and silver for U-bolts.

2. Safety

A U-bolt is a safety component, and it must always be replaced when it loosens. During installation, using the recommended high tightening torque, the bolt and nut are then deformed so that they hold as effectively as possible. To facilitate handling, Scania supplies the U-bolts in kits that include nuts and mounting parts.

3. Thoroughly tested

Scania U-bolts and spring bolts are tested together with other components such as air bellows, spring shackles and leaf springs in order to create a harmonious suspension system.

SCANIA SHOCK ABSORBERS

TESTED AND ADAPTED FOR SCANIA
VEHICLES

Scania shock absorbers have been specially developed for our customers' vehicles. Tested and approved shock absorbers provide the best experience in terms of comfort, safety and operating economy.



SHOCK ABSORBER FACTS

Developed for tough environments

Shock absorbers for heavy vehicles must be able to withstand extreme conditions while operating. Depending on application, it is recommended that shock absorbers shall be replaced after operating for 200 000–400 000 kilometres. Worn-out shock absorbers cause increased wear on other components in the system, including the cab suspension and seat suspension, which affects driver comfort and generates increased costs. Worn shock absorbers can also increase the risk of powertrain shake, which impairs traction, especially for construction vehicles since they often operate on soft ground, such as sand or soil. Worn-out shock absorbers also cause poor road holding, which increases tyre wear as well as the risk of accidents.

WHAT WE HAVE DONE

1. Adapted for Scania

Scania's shock absorbers are well-adapted for our customers' vehicles. With the right suspension characteristics, damping effect, power and piston strokes, the shock absorbers provide optimal properties for the suspension system.

2. Thoroughly tested

To ensure that Scania's shock absorbers provide the best possible damping, they have been tested in rigs and undergone long-term testing over several million kilometres in actual operation. Scania spends thousands of hours to ensure that driving characteristics are optimised for each unique vehicle. The interaction between shock absorbers and other components in the suspension system must combine to provide optimum comfort and service life.

3. Time for replacement

Shock absorbers wear out and need to be replaced on time because functioning shock absorbers reduce stresses on other components. We recommend replacing on both sides at the same time because if one side has new shock absorbers then that side will regain its original capacity and the vehicle will feel unbalanced. Scania shock absorbers are therefore available in kits of two, including mounting parts.



SCANIA ALTERNATOR

ENSURES THE POWER SUPPLY

Scania alternators have been developed to provide high output and efficiency, as well as to have a long service life. This results in greater uptime and thereby better operating economy.

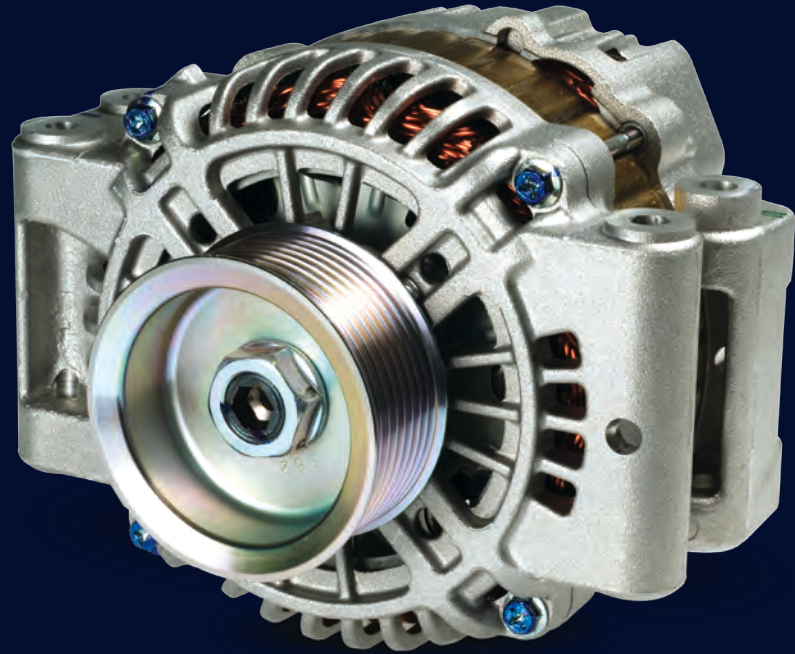

ALTERNATOR FACTS

The vehicle's power plant

The alternator must be able to charge the battery bank quietly and quickly and supply electricity to the vehicle's equipment and components. A good sized alternator output for every application and a controlled charge regulation help ensure starting and also extend the service life of the batteries. Driving cycles involving a lot of idling, lots of stops or equipment powered by electricity, such as tail lift and cab cooler, demand even more of the alternator. This is why it is important for it to supply a high output even at low rotational speeds.

WHAT WE HAVE DONE

1. Optimised design

Scania alternators are available in several different versions to suit different vehicles and operating conditions:

- Unique cooling structure to supply maximum output per weight.
- Unique winding technology for efficient charging and low sound level.
- Developed to withstand the high temperature to which the components around the engine are exposed.

2. Heat resistance.

New emission requirements for hotter engines. To withstand the high temperatures to which the alternator is exposed, the following improvements have been made:

- Temperature resistant winding wire.
- Highly efficient cooling technology.
- High temperature grease in the ball bearings.
- Welded connections.



SCANIA STARTER MOTOR

TROUBLE-FREE STARTING
EVERY DAY

A robust starter motor with a high torque and good cold starting properties ensures that the vehicle starts every time. The starter motors are adapted and tested for Scania vehicles.

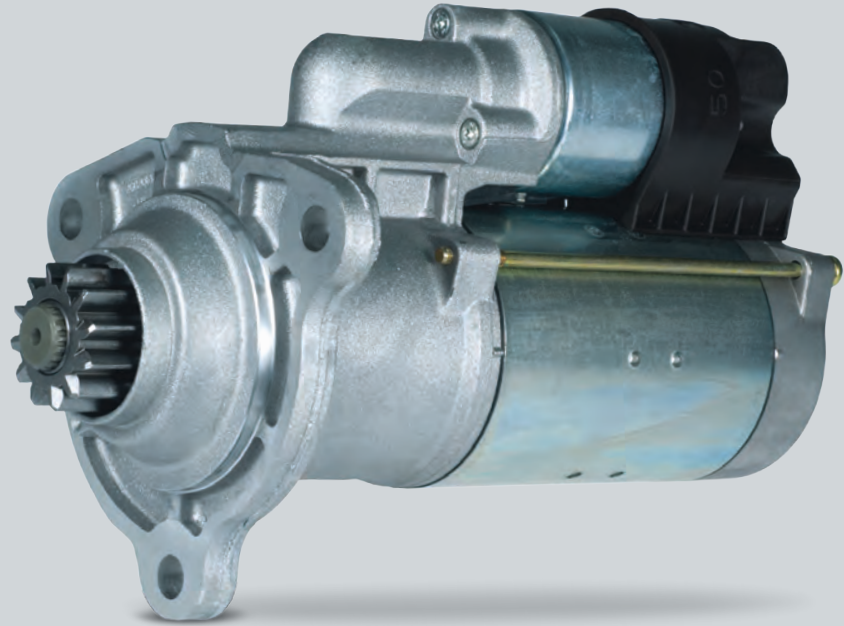

STARTER MOTOR FACTS

Everything starts with the starter motor

The starter motor has the important task of getting the engine started – all year round, over and over again. To start a large diesel engine, a powerful starter motor is required, with high output and high torque. In an emergency, a vehicle with a manual gearbox must be capable of being driven on the starter motor for over 60 seconds so that it can be moved to a safer place if it is disabled.

WHAT WE HAVE DONE

1. Optimal balance

Scania starter motors have been developed to provide an optimal balance between output, torque, weight and service life.

2. Continuous improvements

The starter motors undergo continuous improvement, mainly to increase reliability and extend service life. The starter motor for Scania's inline engines has a new electric motor with improved cold starting properties, improved reliability and extended service life.

3. Advantages for the customer

- High cold starting performance
- Robust design
- Extended service life
- Overload protection
- IP enclosure rating
- Heat protection
- Extra protection against dust and water

SCANIA LIGHTING

MODELS FOR ALL APPLICATION
AREAS

Scania is constantly developing its range in order
to improve performance and durability.

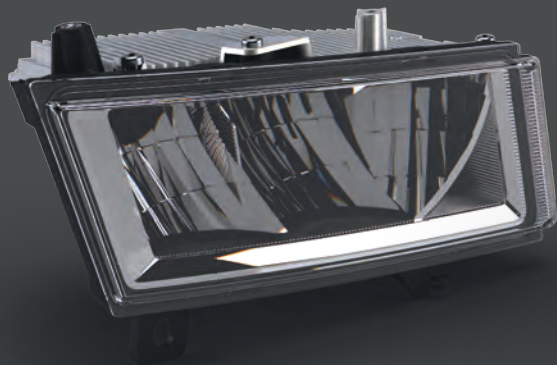
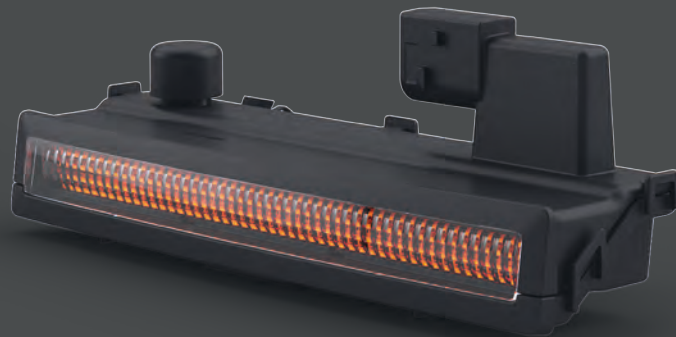

LIGHTING FACTS

An efficient lighting system is required to allow the driver of a truck or bus to see obstacles and to allow the vehicle to be seen by other road users. A truck has many different types of lamp with a range of performance levels, such as traditional bulbs, halogen lamps and Xenon lamps. The daytime running light in the LED headlamp creates a signature light, and this makes the truck easily distinguishable among other vehicles. The light-emitting diodes produce a whiter and more relaxing light compared with halogen or xenon lights.



WHAT WE HAVE DONE

The headlamp with LED light sources for all light functions is introduced into future generations and provides several advantages:

- Designed to last the life of the vehicle
- Only combined with automatic level adjustment
- Equipped with diaphragm ventilation which makes the lamp watertight

Halogen headlamps with H7 and H4 bulbs for dipped beam and main beam are introduced in future generations. The headlamp can be equipped with a levelling motor that is fitted on the inside of the headlamp.

Foglight, indicator and cornering lamps have been developed to adapt the light temperature for lamps with LED technology.

In addition, auxiliary lights in the grille and high-level cab lighting have been introduced with LED technology and provide additional main beam performance.

SCANIA BATTERIES

RELIABLE EVEN AT EXTREME TEMPERATURES,
ON UNEVEN ROADS AND AFTER MANY
CHARGING PROCEDURES

Scania batteries offer high reliability and a long service life. They are designed and tested by Scania to ensure that they can handle the toughest operating conditions.



BATTERY FACTS

Power supply for heavy vehicles

The battery affects uptime to the highest degree and it is of the utmost importance to use batteries with the correct performance.

The fact is that batteries are currently the cause of the majority of unplanned stoppages. This is why it is even more important to use batteries of the correct quality.

Today's trucks and buses contain a lot of electronics that demand a high-capacity power supply. This therefore means that the battery faces hard work.

- The battery must ensure there is power to always be able to start the truck
- The battery must have a long service life
- The battery must withstand powerful vibration from uneven terrain
- The battery must withstand many charging procedures
- The battery must have a fast charging time
- The battery must withstand a range of temperatures
- The battery must supply power to the various functions of the truck

WHAT WE HAVE DONE

Maximising the truck's uptime

Currently, Scania R&D thoroughly develops and tests its own batteries. Everything possible to ensure that they can handle a range of operating conditions. Scania does this to place additionally tough demands over and above those of the battery manufacturers. Amongst other things, they undergo 100-hour vibration tests (shake-testing of the batteries in all directions) in order to check that they can withstand uneven terrain. Durability tests are also carried out to ensure that the battery can handle a certain number of charging procedures without losing power, and that the battery can handle different types of climate.

Scania is the only truck manufacturer currently developing its own batteries.

SCANIA SPIRAL CABLES

TRAILER CABLES AND CONNECTORS THAT MAINTAIN CONTACT

Scania spiral cables and connectors ensure contact with the trailer. The effective seal against moisture means that high-pressure washing is no problem. A change in spiral diameter with more built-in cables improves electrical and mechanical performance and simplifies connection, with fewer tangled cables.



SPIRAL CABLE FACTS

Good connection

The electrical connection between vehicle and trailer must always be in good condition so that the vehicle is safe to drive and complies with regulations in force. The spiral cables must ensure the connection in all the seasons of the year and under all driving conditions. The cables are located in a very demanding environment and are exposed to dirt, salt and rain. They must be able to withstand both low and high temperatures and be watertight.

WHAT WE HAVE DONE

1. Watertight and not temperature-sensitive

Scania spiral cables have been developed to work in a wide range of temperatures, from -40 to +105 degrees. The connectors have a good seal against moisture and are compliant with IP class XPX9K. Scania also offers cost-effective repair kits.

2. Hardwearing but flexible

Scania spiral cables have a small spiral diameter in order to improve mechanical strength and to increase flexibility. The cable connections are reinforced with glass fibre to increase their strength.

3. ADR approval

Scania spiral cables with connectors for ABS, EBS and 15-pole contact are ADR-approved.

SCANIA WINDSCREEN

FOR SAFETY AND COMFORT

A Scania windscreen fitted by skilled staff maintains the same high quality and meets the same requirements for safety as the original factory-fitted windscreen that the vehicle was equipped with on delivery.



WINDSCREEN FACTS

The windscreen is more than just a pane of glass

The windscreen is an important part of the vehicle and contributes to both safety and driving comfort. This makes the cab structure more torsionally rigid, which protects the driver more effectively in the event of a collision. The windscreen must withstand wind and rain as well as the varying pressures from the air flow. It must also be scratch-resistant and resistant to stone chips and collision forces.

WHAT WE HAVE DONE

1. Driving comfort

The Scania windscreen has been developed to provide the best possible driving comfort. It has been specially designed to maintain its shape, size and colour tone.

2. Impact safety

Many design hours have been invested in developing the windscreen to withstand the forces generated in a collision. The entire cab structure, including the windscreen, has been tested to ensure it meets the stringent requirements set for cab impact testing.

3. Maintained safety with new windscreen

Scania windscreens are manufactured in a certified process, with strict quality controls, for a precise fit on Scania vehicles. When a new windscreen is fitted, it is important to use the correct method and glue quality. New windscreens with built-in technology in the form of a bracket for light and rain sensors, for example, are available for later generations. A Scania windscreen fitted by skilled staff maintains the same high quality and meets the same requirements for safety as the original factory-fitted windscreen.



SCANIA WIPER BLADES

ADAPTED FOR DIFFERENT
CLIMATES

Scania wiper blades use advanced rubber technology to provide the best possible performance. Replacing them every year maintains safety and comfort, even under extreme weather conditions.

WIPER BLADE FACTS

Important for safety

It is important for safety and driver comfort to keep wiper blades in good condition so that they effectively remove rain, dirt and snow from the line of vision. The rubber is exposed to sunlight, extreme weather conditions and contaminants, which reduces their wiping ability over time.

Noise, streaks of water or a film of water on the windscreen are all signs that the wiper blades are starting to lose their wiping ability. This impairs visibility and therefore compromises safety.

WHAT WE HAVE DONE

1. Material in the core

Scania wiper blades are made from a combination of synthetic rubber and natural rubber which are extruded together. The upper part of the wiper blade, the core, is made of synthetic rubber in order to reduce the risk of vibration and cracks. In later generations, the wiper nozzle is installed in the wiper blade to obtain a more efficient distribution of washer fluid.

2. Material in the lip

The lower part of the wiper blade, the lip, is made of natural rubber, which ensures high wiping quality on long wiper blades. This material effectively reduces noise, vibration, coatings and wear on the windscreen. Another advantage of natural rubber is that it remains soft, even in very cold climates.

3. Works in different climates

The material compound in Scania wiper blades has been tested to ensure that it can withstand both cold and hot climates. Apart from safety and comfort reasons, the wiper blades should be replaced every year to avoid damage to the windscreen.

SCANIA CAB SUSPENSION

DEVELOPED FOR COMFORT

Scania cab suspension has been developed and tested for maximum comfort in order for customers to have the best possible driving experience on all surfaces.



CAB SUSPENSION FACTS

Finely adjusted cab damping is important for comfort

The interaction between the air bellows and/or the mechanical spring and the shock absorber must be thoroughly tried and tested for each operating situation. It is extremely important to have the right characteristics in the system. Incorrect cab suspension, which is not optimised for the cab, will generate an unnecessarily large amount of vibration and rolling. This can wear out the driver quickly, thereby increasing the risk of driving errors.

Incorrect damping in the cab suspension also causes increased wear and, in a worst-case scenario, damage to other parts of the cab suspension.

The suspension settings are optimised to avoid the risk of full suspension compression and other consequential faults that have a negative impact on the driver environment.

WHAT WE HAVE DONE

1. Unique combinations

The Scania air bellows and shock absorbers in the cab suspension have been developed for the best possible comfort and service life. Every cab height, length, weight and pattern of movement are simulated and carefully considered during the development of the products. Scania places the utmost importance on specifying the right suspension for each customer's unique cab type.

2. Separate parts

The system is thoroughly adapted for the customers' vehicles. All parts interact in order to achieve the best possible comfort on all surfaces. If a spring is worn out then it is recommended to replace on both sides at the same time to optimise driver comfort and wear.

3. Testing

During a normal service life, the springs will be subjected to millions of damping movements every year and must work in all occurrences. Scania conducts thorough testing in actual and simulated environments so that the springs can handle all tough conditions.

SCANIA CAB AIR FILTER

CLEAN, FRESH AIR IN THE CAB

Scania cab air filters provide a healthier driver environment. Dirt, dust, pollen and other small particles are effectively filtered out. The filter is designed to provide effective filtration without obstructing the air flow. The heating and cooling performance will be optimal when the air flow is correct.

The Scania HVAC climate system (heating ventilation air conditioning) has been introduced in later generations and has been tested to optimise correct air flow.



CAB AIR FILTER FACTS

Filtration of smaller particles

Fresh air in the cab is essential for the driver to be able to concentrate during long driving stints. A prefilter removes leaves, insects and other large objects, while the cab air filter stops smaller particles such as dust, pollen and soot. The cab air

filter is fitted in the intake port for the cab fan. The geometry and material of the filter are crucial for the fan to be able to supply the correct air volume to the cab and for obtaining the best possible heating and cooling performance.

WHAT WE HAVE DONE

1. Correct sealing integrity

The Scania cab air filter has a thoroughly tested sealing integrity. If the filter is too sealed or open then this will result in an incorrect air flow to the cab, thereby impairing climate regulation.

2. High dimensional stability

The filter has high dimensional stability. A filter of poorer quality may collapse, in either the filter frame or the filter medium, and then allow unfiltered air through to the climate system. This may cause the cab fan to malfunction and mould to form on the evaporator.

3. Does not bind moisture

Scania uses polypropylene as its filter medium as it does not bind moisture to the same extent as cellulose. A filter that absorbs moisture provides

impaired heating and cooling performance and may, in a worst-case scenario, cause misting or ice on the windows.

4. Different performance levels

- Automatic Climate Control
Air conditioning with automatic temperature control
- Premium Automatic Climate Control
Air conditioning and combinable additive with heater. The system also has an air quality sensor with carbon filter to remove odours
- Manuel Climate Control
Air conditioning where the filter has been specially developed for particularly heavy operating conditions. The Scania Heavy Duty filter with more rigid surface layer can also be cleaned of dust.

SCANIA OIL

A VITALLY IMPORTANT ORIGINAL SPARE PART

Scania Oil is currently supplied in exactly the same way as all Scania original spare parts.

Scania Oil has been developed and tested by Scania research and development and is based on clearly defined technical requirements currently demanded by the Scania powertrain.



OIL FACTS

Extremely tough requirements to meet

The function of the lubricating oil is to reduce the friction between two moving metal surfaces, remove impurities and conduct heat away, which prevents wear and improves fuel economy. A good oil must also have the correct viscosity for different operating temperatures. Above all, the oil must keep engine components clean, prevent coking and sludge. In addition, a good oil must not have any negative effect on the aftertreatment system.

A good oil is an optimised combination of the right base oils and the right additive package. Everything possible to offer the best possible performance.

Summary:

- The oil must protect the powertrain from wear
- The oil must allow long change intervals
- The oil must minimise the effect on the aftertreatment system
- The oil must maximise fuel savings
- The oil must minimise oil consumption
- The oil must meet legal requirements and minimise environmental impact

WHAT WE HAVE DONE

1. Best performance – designed and developed by Scania

Today, Scania is the only truck manufacturer that uses long-term testing for the purpose of testing the oil and engine in actual operation. Scania tests the oil for the entire oil change interval, which makes Scania Oil unique.

2. Highest quality - Checked by Scania

Exactly as with all Scania original spare parts, the quality is monitored closely by Scania at our suppliers. A dedicated department at Scania (Scania Quality Assurance) carries out tests to ensure that the quality of the oil meets the requirements set.

3. Tailored product

Scania Oils are always tested in a Scania vehicle, something not done for other oils. Today's powertrains have a high-technology design, and there are significant differences between powertrains from different truck manufacturers. For this reason, Scania vehicles must be used for testing in order to be able to make a correct assessment of an oil's suitability for Scania powertrains.

SCANIA COOLANT

OPTIMISED FOR SCANIA
ENGINES AND CLIMATE
SYSTEMS

Scania coolant is the only coolant approved by Scania. The coolant is developed to meet Scania's engines and climate systems requirements and proven by long-term testing in actual operation. It must not be mixed or diluted with other coolants. Scania coolant provides the best possible protection against hidden damage and protects the sensitive HVAC climate system.



COOLANT FACTS

Cooling is just one of its functions

Modern engines and cooling systems use aluminium to reduce weight. However, aluminium requires more protection against precipitation and corrosion. In the event of precipitation or corrosion, damage may remain hidden for several years and thereby cause major problems and lead to expensive repairs and downtime.

Countries with hot climates in particular have experienced problems with corrosion due to leakage in top cover gaskets and seals. Some parts are sensitive to water but not glycol, and this indicates over-dilution. This is why it is important to use ready-mixed coolant for topping-up.

In addition, improved HVAC climate systems have very thin pipes. Normal frost creates precipitation that quickly clogs the climate system, which can lead to total loss of heating or cooling capacity, making the vehicle temporarily undriveable.

WHAT WE HAVE DONE

Maximum protection and performance

Coolant from Scania is thoroughly tested and adapted for Scania engines and climate systems with triple protection in the form of boiling protection, frost protection and corrosion protection. Scania coolant contains a special, highly effective corrosion additive that provides much better service life and stability at high temperatures than additives used in conventional coolant. The fluid is degradable for minimal possible environmental impact. There is much the coolant is expected to cope with, and the performance is checked and assessed carefully for correct:

- Antifreeze protection
- Protection against boiling
- Corrosion protection all-year round
- Protection against deposits that can clog narrow passageways
- Correct protection against cavitation
- The only coolant that can handle this is Scania Coolant

