

## SCREAMIN' EAGLE® PERFORMANCE

GET THE LOOK, FEEL, AND PERFORMANCE YOU EXPECT TO FIND AT A RACE TRACK WITH THIS POWERFUL LINEUP OF STREET-LEGAL AIR CLEANERS, ENGINE KITS, AND EXHAUST COMPONENTS. YOU'LL GET ALL THE ATTENTION YOU CRAVE, WITHOUT ANY YOU DON'T WANT.



GENUINE MOTOR PARTS & ACCESSORIES

Not all products are available in all countries — please consult your dealer for details.

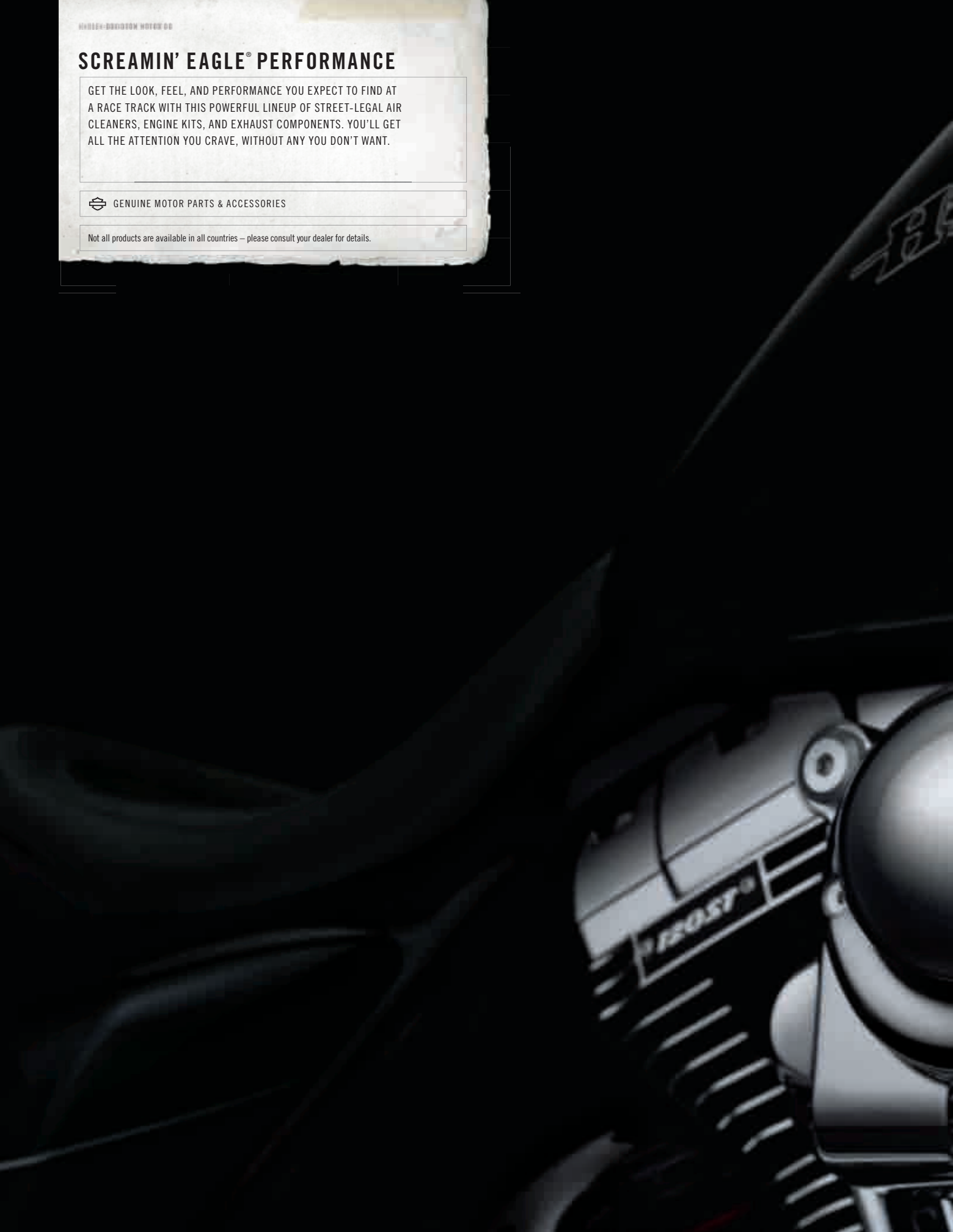



Harley-Davidson

Screamin' Eagle

## PERFORMANCE TUNING

Modifying an EFI-equipped motorcycle for improved performance is similar to modifying a carbureted model, in that freer-flowing intake and exhaust systems will require more fuel, and increased displacement and compression will require more fuel and spark timing changes. The Screamin' Eagle® family of EFI Tuners provide the computer-based tools you need to record and edit the ECM tuning tables for fuel delivery and spark timing. The Tuning mode allows you to alter specific variable in your EFI system, and the Data mode enables you to record and display real-time vehicle data and graph the results on screen. The Tuner software also includes a variety of pre-tuned calibrations that can be saved and loaded into your ECM.



Screamin' Eagle Street Performance Tuner

### SCREAMIN' EAGLE® STREET PERFORMANCE TUNER KIT

The Screamin' Eagle® Street Performance Tuner is designed to simplify management of street legal performance calibrations as EPA/CARB-compliant performance modifications are made. Once installed, the kit will allow you to upload the latest ECM calibrations for your bike's legal state-of-tune. Start with a high-flow air cleaner and Street Performance mufflers and upload the calibration that provides the best performance mix. Add a Big Bore Stage I or Stage II Kit later and simply download the proper ECM calibration to match the model and hardware. Plus, you have online access to the latest factory calibrations.

The kit includes the Vehicle Communications Interface (VCI) module with on-board memory that can record up to 15 minutes of run-time data. The module will store information on up to 27 variables that can be downloaded to your PC via an optional USB cable, allowing the rider or technician to view and evaluate engine operating parameters. With the included software, you can download and view the bike's air/fuel ratio, O2 sensor readings, engine speed and temperature, RPM and vehicle speed, throttle position, spark advance and many more performance characteristics. The VCI will also record and display service codes for troubleshooting and diagnostics.

#### The Street Tuner software includes impressive features:

- Smart Tune Live – a dynamic and visual method to track and capture engine data simply by running the vehicle through a range of RPM and Throttle Positions. This feature reduces the time to modify existing VE (Volumetric Efficiency) tables which are then analyzed and tuned. Smart Tune Live works on models with factory-installed O2 sensors only.
- Interpolation of missing data derived from recordings, which reduces analysis time by automatically generating data that might be missed in the recording process.
- Viewable data meters doubled from 4 to 8 allowing users to monitor more real-time data. Users can now save and restore data meter configurations which are viewable in both traditional data modes and the new Smart Tune Live.
- Increased sampling rate to take advantage of the faster ECM data speeds found on select '11-later models (CAN protocol).
- Revised tuning tree with intuitive double click features.

NOTE: Street Tuner permits limited tunability within the emissions range to optimize drivability without compromising emission levels. It also features expanded tuning options outside of the emissions range to optimize performance.

#### 41000008B

For use with '14-later XL and '07-later EFI Dyna®, Softail® and Touring models.

#### Also available:

#### SCREAMIN' EAGLE TUNER CABLE KIT

Cable kit provides all necessary connections between motorcycle, VCI and computer and permits downloading calibrations with the Street Tuner and Super Tuner software. Kit includes two cables; computer USB to VCI box and VCI box to vehicle.

#### 32184-08A

For use with '01-later VRSC™, '01-'13 EFI XL and XR, '01-'11 EFI Dyna, '01-'11 EFI Softail®, '02-'13 EFI Touring and '09-'13 Trike models. Also for use with VRSXSE Destroyer™ race bike.

#### 41000018

For use with '14-later XL, '12-later Dyna, '11-later Softail, '14-later Touring and '14-later Trike models.

### FEATURES

	STREET TUNER
<b>Street-Use (EPA/CARB) Calibrations</b>	Yes – Stage 1, 2 & 4
<b>SE Pro (Race-Use Only) Calibrations</b>	No
<b>Retains Full Engine Warranty</b>	Yes
<b>Tuning Parameters:</b>	
<i>Air Fuel Ratio</i>	Tunable – All
<i>Throttle Progressivity</i>	Tunable – '14-later Touring
<i>Spark Advance</i>	Tunable – '14-later Touring and XL, '12-later Softail and Dyna
<i>RPM Max</i>	View Only
<i>Idle RPM</i>	View Only
<i>Accel Enrichment</i>	View Only
<i>Decel Enleanment</i>	View Only
<b>Data Recording</b>	15 minutes
<b>Smart Tune LIVE</b>	Yes
<b>Graphical Data Display</b>	Yes
<b>Service Codes Display/Clear</b>	Yes
<b>Available for VRSC and XR models</b>	No
<b>International Calibrations/Compatible</b>	No
<b>Language Support</b>	English Only



**TOOLBOX – Data Item Graphing with Meters**

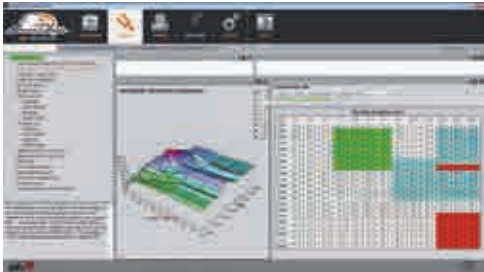

**TUNER – ECM Mapping with Graphic Data**



PUSH-TO-RECORD  
BUTTON

VEHICLE COMMUNICATIONS  
INTERFACE (VCI) MODULE

DATA RECORDER  
INDICATOR LAMP

## 470 SCREAMIN' EAGLE®

Air Cleaner Kits

### A. SCREAMIN' EAGLE® STREET PERFORMANCE HIGH-FLOW 58MM EFI THROTTLE BODY

The biggest engines deserve the most fuel and air. This huge 58mm Throttle Body (8mm or 16% larger than stock) won't leave your engine starving for more air. The one-piece throttle body features Electronic Throttle Control technology. Just add your stock injectors. Choose from several different 58mm compatible high-flow air cleaner kits to feed this big-mouthed beast. All EFI equipped models require ECM calibration\* (sold separately).

#### 27200029

Fits '16-later FLSS and FLSTFBS, and '14-later CVO™ Touring models equipped with 110CI engines. Also fits '14-later Touring and Softail® models equipped with Screamin' Eagle® 110 Street Performance Upgrade Kits P/N 92500020, 92500031, 92500032 and 27508-11. Does not fit Trike models. Requires separate purchase of a 58mm Air Cleaner.

\*Recalibration is required for proper installation. See Dealer for details. Labor cost not included.

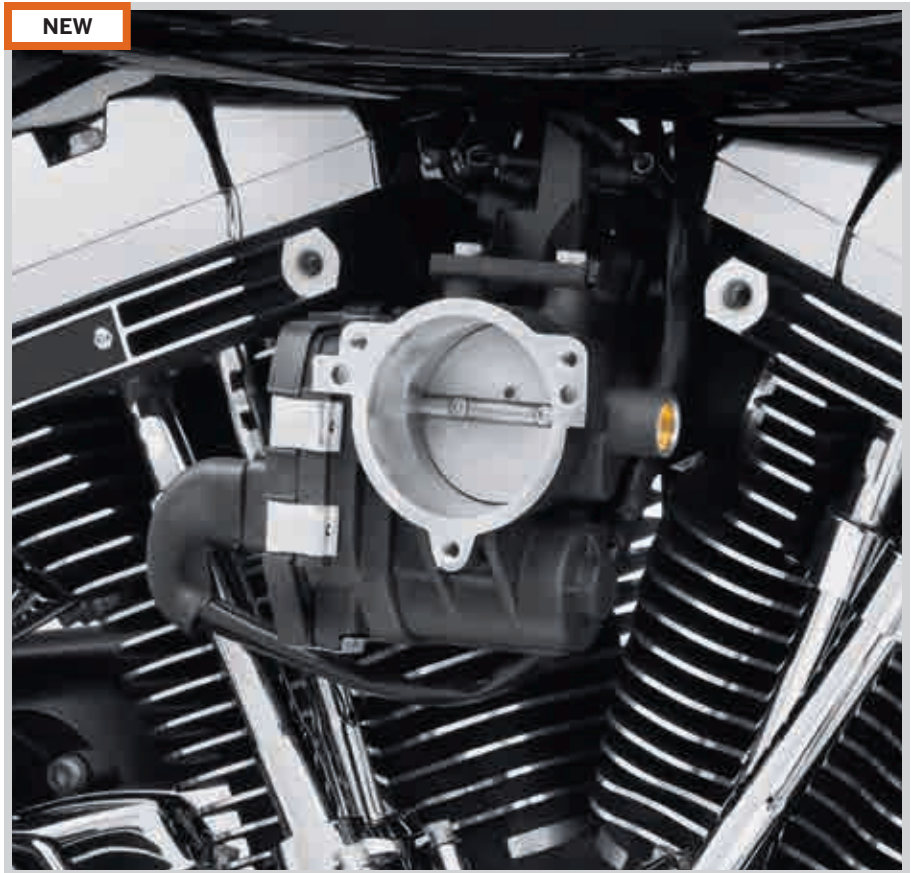

A. SCREAMIN' EAGLE STREET PERFORMANCE HIGH-FLOW 58MM EFI THROTTLE BODY



A. SCREAMIN' EAGLE STREET PERFORMANCE HIGH-FLOW 58MM EFI THROTTLE BODY

*Not all products are available in all countries – please consult your dealer for details.*



**NEW**

# SCREAMIN' EAGLE® 471

Air Cleaner Kits

## B. SCREAMIN' EAGLE® PERFORMANCE AIR CLEANER KIT – THE RAIL COLLECTION

The look is bold and the performance exhilarating. This race-inspired air cleaner is engineered to flow through the perimeter and the face of the air filter, providing high volumes of unrestricted airflow to the engine. The open-design face plate features a rich black finish with machined longitudinal strakes to expose the glowing aluminum below. Kit includes air cleaner trim, one-piece cast back plate, high-flow washable air filter element, rain sock and all required hardware. All EFI-equipped models require ECM calibration\* (priced separately).

**29400232**

Fits '07-later XL models with Original Equipment throttle body.

\*Recalibration is required for proper installation. See Dealer for details. Labor cost not included.

## C. SCREAMIN' EAGLE PERFORMANCE AIR CLEANER KIT – THE BURST COLLECTION

Performance and style combined. Designed to complement the Burst Collection, this radical low profile air cleaner features a "tuxedo black" surround that has been expertly machined to expose the satin aluminum finish below. The billet cover conceals a one-piece cast back plate with integral breather and mounting bracket that promotes smooth air flow into the throttle body. The exposed reverse cone cotton element provides high-volumes of air and the element is washable for maximum efficiency and protection. The complete kit includes Burst Collection trim, backing plate, air cleaner element and all required installation hardware. All EFI-equipped models require ECM calibration\* (priced separately).

**29000066**

Fits '16-later Softail® and '08-later Touring and Trike models with Original Equipment 50mm throttle body. Also fits '16-later Softail, '14-later CVO™ Softail and '14-later Touring models equipped with Screamin' Eagle® 58mm Throttle Body.

**29400178**

Fits '08-later Dyna® and '08-'15 Softail models (except '11-'12 FLSTSE, '13-'14 FXSBSE and '14-'15 FLSTNSE).

\*Recalibration is required for proper installation. See Dealer for details. Labor cost not included.

NOTE: The washable and rechargeable filter uses a special coating to help filter fine particles from the incoming air. With time, the oil in the filter will dissipate and the element will begin to turn gray. The original red color can be restored with an application of K&N® Air Filter Oil.

**B. SCREAMIN' EAGLE PERFORMANCE AIR CLEANER KIT – THE RAIL COLLECTION**



**C. SCREAMIN' EAGLE PERFORMANCE AIR CLEANER KIT – THE BURST COLLECTION**



**NEW**



**B. SCREAMIN' EAGLE PERFORMANCE AIR CLEANER KIT – THE RAIL COLLECTION**

**C. SCREAMIN' EAGLE PERFORMANCE AIR CLEANER KIT – THE BURST COLLECTION**

Not all products are available in all countries – please consult your dealer for details.

# 472 SCREAMIN' EAGLE®

Air Cleaner Kits

## A. SCREAMIN' EAGLE® EXTREME BILLET AIR CLEANER KIT

The bold styling of this intake system looks just as impressive as the long patch of burnout rubber you just laid down. The forged billet aluminum cover tops off a cast back plate with integral breather for a smooth transition to the throttle body. The race-inspired air cleaner is engineered to flow high volumes of air and the washable pleated element provides the ideal combination of efficiency and engine protection. Available in your choice of style and finish, this easy-to-install kit includes all mounting hardware and rain sock. All EFI-equipped models require ECM calibration\* (priced separately).

Fits '16-later Softail® and '08-later Touring and Trike models with Original Equipment 50mm Throttle Body.

<b>29400064</b>	Agitator – Chrome.
<b>29400063</b>	Agitator – Cut Back Gloss Black.
<b>29400104</b>	Chisel – Chrome.
<b>29400103</b>	Chisel – Cut Back Gloss Black.

Fits '16-later Softail, '14-later CVO™ Softail and '14-later Touring models equipped with Screamin' Eagle® 58mm Throttle Body.

<b>29400221</b>	Chisel – Chrome.
<b>29400220</b>	Chisel – Cut Back Gloss Black.

Fits '08-later Dyna® and '08-'15 Softail models (except '11-later CVO Softail).

<b>29400116</b>	Chisel – Cut Back Gloss Black.
<b>29400117</b>	Chisel – Chrome.

Fits '07-later XL models with Original Equipment throttle body.

<b>29400127</b>	Chisel – Cut Back Gloss Black.
<b>29400128</b>	Chisel – Chrome.

\*Recalibration is required for proper installation. See Dealer for details. Labor cost not included.

NOTE: The washable and rechargeable filter uses a special coating to help filter fine particles from the incoming air. With time, the oil in the filter will dissipate and the element will begin to turn gray. The original red color can be restored with an application of K&N® Air Filter Oil.



A. EXTREME BILLET AIR CLEANER KIT – AGITATOR, CHROME



A. EXTREME BILLET AIR CLEANER KIT – AGITATOR, CUT BACK GLOSS BLACK



A. EXTREME BILLET AIR CLEANER KIT – CHISEL, CHROME



A. EXTREME BILLET AIR CLEANER KIT – CHISEL, CUT BACK GLOSS BLACK



A. EXTREME BILLET AIR CLEANER KIT



A. EXTREME BILLET AIR CLEANER KIT (SHOWN WITH RAIN SOCK)

Not all products are available in all countries – please consult your dealer for details.

# SCREAMIN' EAGLE® 473

Air Cleaner Kits

## B. SCREAMIN' EAGLE® HEAVY BREATHER ELITE PERFORMANCE AIR CLEANER KIT

Really open it up. This Heavy Breather Elite Air Cleaner features a forward-facing filter element that flows huge volumes of clean air. The low-profile cast elbow and the oval cross-section element combine to hug the engine to provide increased leg room. The intake tube mounts to a custom back plate that features integral breathers and covers the throttle body and electronics for a finished look. Available in your choice of chrome or gloss black finish, the Heavy Breather Elite kit features a washable and re-chargeable filter features bright chrome end caps and trim with Screamin' Eagle script. Kit includes filter, intake tube, custom back plate, water-repellent rain sock and all mounting hardware. All EFI-equipped models require ECM calibration\* (priced separately).

Fits '16-later Softail®, '11-later CVO™ Softail and '14-later Touring and Freewheeler® models. Does not fit models equipped with Twin-Cooled™ engine, fairing lower glove boxes or fairing lower speakers. Also fits '16-later Softail, '14-later CVO Softail and '14-later Touring models equipped with Screamin' Eagle 58mm Throttle Body.

**29400173** Chrome.

**29400172** Gloss Black.

\*Recalibration is required for proper installations. See dealer for details. Labor costs not included.

NOTE: The washable and rechargeable filter uses a special coating to help filter fine particles from the incoming air. With time, the oil in the filter will dissipate and the element will begin to turn gray. The original red color can be restored with an application of K&N® Air Filter Oil.



B. SCREAMIN' EAGLE HEAVY BREATHER ELITE PERFORMANCE AIR CLEANER KIT – CHROME



B. SCREAMIN' EAGLE HEAVY BREATHER ELITE PERFORMANCE AIR CLEANER KIT – GLOSS BLACK



B. SCREAMIN' EAGLE HEAVY BREATHER ELITE PERFORMANCE AIR CLEANER KIT



B. SCREAMIN' EAGLE HEAVY BREATHER ELITE PERFORMANCE AIR CLEANER KIT (SHOWN WITH RAIN SOCK)

Not all products are available in all countries – please consult your dealer for details.



# 474 SCREAMIN' EAGLE®

Air Cleaner Kits

## A. SCREAMIN' EAGLE® HEAVY BREATHER PERFORMANCE AIR CLEANER KIT

This high-flow forward-facing exposed element Air Cleaner Kit is sure to turn heads at the starting line. Featuring a polished elbow and exposed filter, this unique air cleaner system offers improved performance and airflow when compared to the stock or Screamin' Eagle® High-Flow Air Cleaner. The washable and rechargeable filter features a bright chrome end cap with a laser-engraved Screamin' Eagle logo. Intake tube and back plate are made from die-cast lightweight aluminum and are polished and chrome-plated or painted black for a brilliant finish. The back plate features integral breathers and sealed breather bolt plug. Kit includes a water-repellent rain sock and all mounting hardware. All EFI-equipped models require ECM calibration\* (priced separately).

Fits '16-later Softail®, '11-later CVO™ Softail, '08-later Touring and '15-later Freewheeler® models. Also fits '16-later Softail, '14-later CVO Softail and '14-later Touring models equipped with Screamin' Eagle 58mm Throttle Body. Does not fit models equipped with fairing lower glove boxes or fairing lower speakers. Does not fit Twin-Cooled™ models.

**29253-08B** Chrome.

**29006-09B** Gloss Black.

Fits '08-later Touring and '15-later Freewheeler models equipped with Fairing Lower Glove Boxes (except Twin-Cooled models or models equipped with fairing lower speakers). Also fits '16-later Softail, '14-later CVO Softail and '14-later Touring models equipped with Screamin' Eagle 58mm Throttle Body.

**28716-10A** Compact Design – Chrome.

Fits '08-later Dyna® and '08-'15 Softail models except ('11-later CVO Softail).

**29299-08** Chrome.

**29098-09** Gloss Black.

Fits '08-later XL models with Original Equipment Throttle Body.

**29264-08** Chrome.

**29080-09** Gloss Black.

Fits '14-later XL1200 model equipped with Screamin' Eagle High Flow 58mm Throttle Body.

**29400227** Black.

**29400228** Chrome.

\*Recalibration is required for proper installation. See Dealer for details. Labor cost not included.

NOTE: The washable and rechargeable filter uses a special coating to help filter fine particles from the incoming air. With time, the oil in the filter will dissipate and the element will begin to turn gray. The original red color can be restored with an application of K&N® Air Filter Oil.



A. SCREAMIN' EAGLE HEAVY BREATHER PERFORMANCE AIR CLEANER KIT – CHROME



A. SCREAMIN' EAGLE HEAVY BREATHER PERFORMANCE AIR CLEANER KIT – GLOSS BLACK

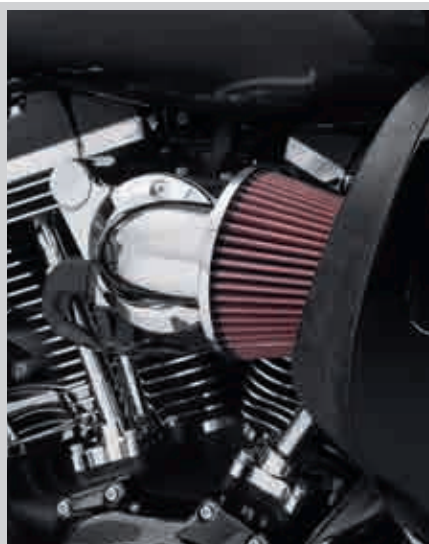

A. SCREAMIN' EAGLE HEAVY BREATHER AIR CLEANER KIT – COMPACT



A. SCREAMIN' EAGLE HEAVY BREATHER PERFORMANCE AIR CLEANER KIT – CHROME



A. SCREAMIN' EAGLE HEAVY BREATHER PERFORMANCE AIR CLEANER KIT – GLOSS BLACK

Not all products are available in all countries – please consult your dealer for details.

# SCREAMIN' EAGLE® 475

Air Cleaner Kits



**B. SCREAMIN' EAGLE HEAVY BREATHER FILTER COVER – TEARDROP, CUT BACK GLOSS BLACK – SIDE LOGO**

## B. SCREAMIN' EAGLE® HEAVY BREATHER FILTER COVER – TEARDROP

Dress up the Heavy Breather Air Cleaner with this radical cover. Manufactured from forged aluminum and precision CNC-machined and polished, these easy-to-install two-piece covers add a rich custom look. Cover is available in mirror-chrome or cut back gloss black finish to match your customizing direction. Kit includes water-repellent rain sock.

Fits Heavy Breather Air Cleaner filter elements (except Compact Heavy Breather P/N 28716-10 or Heavy Breather Elite P/N 29400173 and 29400172). Does not fit with decorative filter end caps.

**29400061** Cut Back Gloss Black – Side Logo.

**28739-10** Cut Back Gloss Black – End Logo.

**28740-10** Chrome – End Logo.

## C. SCREAMIN' EAGLE HEAVY BREATHER DECORATIVE ENDCAP – WILLIE G SKULL

Add a sinister touch to your Heavy Breather Air Cleaner. Chrome-plated self-adhesive cover features a forward-facing Willie G Skull medallion.

**28720-10**

Fits models equipped with Screamin' Eagle® Heavy Breather Air Cleaner Kits (except Compact Heavy Breather P/N 28716-10 or Heavy Breather Elite P/N 29400173 and 29400172).

## D. SCREAMIN' EAGLE HEAVY BREATHER DECORATIVE MEDALLION

Add the finishing touch to your Heavy Breather Air Cleaner by installing this medallion. Featuring a bright chrome-plated die-cast base and contrasting black inlay with diamond cut "Screamin' Eagle" script. Easy to install.

**29017-09**

Fits models equipped with Heavy Breather Air Cleaner Kits (except Compact Heavy Breather P/N 28716-10 or Heavy Breather Elite P/N 29400173 and 29400172).

## E. THROTTLE BODY COVER

This cover dresses the area between the Twin Cam cylinders for a custom look. The formed cover hugs the contour and conceals the electronic control module throttle body for a clean appearance. Available in your choice of mirror chrome or gloss black finish. Easy-to-install kit includes gaskets.

Fits '14-'15 FLSTNSE, '11-'12 FLSTSE, '13-'14 FXSBSE and '16-later Softail, '08-later Touring and Trike models equipped with Screamin' Eagle Heavy Breather or Burst Air Cleaner Kit.

**61300109** Chrome.

**61300110** Gloss Black.



**B. SCREAMIN' EAGLE HEAVY BREATHER FILTER COVER – TEARDROP, CHROME**



**B. SCREAMIN' EAGLE HEAVY BREATHER FILTER COVER – TEARDROP, CUT BACK GLOSS BLACK**



**C. SCREAMIN' EAGLE HEAVY BREATHER DECORATIVE ENDCAP – WILLIE G SKULL**



**D. SCREAMIN' EAGLE HEAVY BREATHER DECORATIVE MEDALLION**



**E. THROTTLE BODY COVERS**



Not all products are available in all countries – please consult your dealer for details.

## 476 SCREAMIN' EAGLE®

Air Cleaner Kits

### A. SCREAMIN' EAGLE® EXTREME BILLET VENTILATOR AIR CLEANER KIT

The proven, track-inspired exposed element Ventilator air cleaner with a completely totally unique look. This low-profile oval air cleaner features a 360° exposed filter element for maximum air flow and a stylish machined billet aluminum cover for style. Available in your choice of chrome or cut back gloss black finish, the two-piece billet cover surrounds the filter and features a full color Screamin' Eagle® medallion. The cast back plate ensures smooth air flow to the throttle body and the included rain sock protects the filter and engine from drawing in moisture during inclement weather. This easy-to-install kit includes billet air cleaner cover, high-flow filter element, back plate, protective rain sock and all required installation hardware. Street legal when used with stock mufflers. All EFI-equipped models require ECM calibration\* (priced separately).

Fits '16-later Softail® and '09-later Touring and Trike models. Also fits '11-later CVO™ Softail models.

**29400163** Chrome.

**29400164** Cut Back Gloss Black.

Fits '16-later Softail, '14-later CVO Softail and '14-later Touring models equipped with Screamin' Eagle 58mm Throttle Body.

**29400223** Chrome.

**29400224** Cut Back Gloss Black.

Fits '10-later Dyna® and '10-'15 Softail models (except '11-later CVO Softail models).

**29400167** Chrome.

**29400168** Cut Back Gloss Black.

\*Recalibration is required for proper installation. See Dealer for details. Labor cost not included.



A. SCREAMIN' EAGLE EXTREME BILLET VENTILATOR AIR CLEANER KIT – CHROME



A. SCREAMIN' EAGLE EXTREME BILLET VENTILATOR AIR CLEANER KIT – CUT BACK GLOSS BLACK



A. SCREAMIN' EAGLE EXTREME BILLET VENTILATOR AIR CLEANER KIT – CHROME



A. EXTREME BILLET VENTILATOR AIR CLEANER KIT (SHOWN WITH RAIN SOCK)

Not all products are available in all countries – please consult your dealer for details.

# SCREAMIN' EAGLE® 477

Air Cleaner Kits



**B. SCREAMIN' EAGLE VENTILATOR ELITE AIR CLEANER KIT – CHROME**

## B. SCREAMIN' EAGLE® VENTILATOR ELITE AIR CLEANER KIT

This low-profile oval air cleaner features a 360° exposed filter element and a cast back plate designed to provide maximum air flow to the throttle body. This easy-to-install air cleaner produces significant performance gains, while the sleek center bar design cover with carbon fiber inserts add a luxurious touch. This complete kit includes low-profile air cleaner cover, high-flow filter element, back plate, diamond-cut Screamin' Eagle® medallion, protective rain sock and all required installation hardware. Street legal when used with stock mufflers. All EFI-equipped models require ECM calibration\* (priced separately).

Fits '16-later Softail® and '09-later Touring and Trike models. Also fits '11-later CVO™ Softail models.

**29400217** Chrome.

**29400218** Gloss Black.

Fits '16-later Softail, '14-later CVO Softail and '14-later Touring models equipped with Screamin' Eagle 58mm Throttle Body.

**29400219** Chrome.

**29400230** Black.

\*Recalibration is required for proper installation. See Dealer for details. Labor cost is not included.

**Also available:**

## SCREAMIN' EAGLE VENTILATOR ELITE AIR CLEANER COVER

Add a luxurious finishing touch to your Ventilator Air Cleaner. Designed as a direct replacement for the Screamin' Eagle and CVO Ventilator Air Cleaners, this easy to install cover features a sleek center bar design surrounded with carbon fiber inserts. Kit includes low-profile cover, diamond-cut Screamin' Eagle medallion and chrome mounting hardware.

Fits Dyna®, Softail, Touring and Trike models equipped with Screamin' Eagle Ventilator Air Cleaner Kits P/N 29490-09, 29915-09, 28721-10, 28722-10 or 29400039. Also fits Dyna HO103 and CVO models with Original Equipment Ventilator Air Cleaner.

**61300516** Chrome.

**61300517** Gloss Black.



**B. SCREAMIN' EAGLE VENTILATOR ELITE AIR CLEANER KIT – BLACK**



**B. SCREAMIN' EAGLE VENTILATOR ELITE AIR CLEANER KIT**

## C. SCREAMIN' EAGLE VENTILATOR PERFORMANCE AIR CLEANER KIT

Stylish low-profile exposed element air cleaner kit provides increased airflow to boost the power of your fuel-injected engine. The track-inspired exposed element adds a purposeful look to the bike and the included waterproof rain sock protects the filter during inclement weather. This easy-to-install kit includes low-profile air cleaner cover, high-flow filter element, back plate, Screamin' Eagle badge, protective rain sock and all required installation hardware. Street legal when used with stock mufflers. All EFI-equipped models require ECM calibration\* (priced separately).

Fits '10-later Dyna and '10-'15 Softail models (except '11-later CVO Softail models).

**28721-10** Chrome.

**28722-10** Gloss Black.

\*Recalibration is required for proper installation. See Dealer for details. Labor cost is not included.



**C. SCREAMIN' EAGLE VENTILATOR PERFORMANCE AIR CLEANER KIT – CHROME**



**C. SCREAMIN' EAGLE VENTILATOR PERFORMANCE AIR CLEANER KIT – GLOSS BLACK**

Not all products are available in all countries – please consult your dealer for details.

# 478 SCREAMIN' EAGLE®

Air Cleaner Kits

## A. SCREAMIN' EAGLE® PERFORMANCE AIR CLEANER FOR VRSC™ MODELS

This high-flow air cleaner provides the clean stable air the engine needs for maximum performance. The washable filter element does not require oiling.

**29793-02C** Fits '02-later VRSC™ models.

## B. SCREAMIN' EAGLE SPORTSTER® STAGE I AIR CLEANER KIT – OVAL

The XL Stage I Air Cleaner Kit provides increased airflow to boost the power of your fuel-injected Sportster® model. The complete kit features a composite air cleaner back plate, air cleaner cover adapter, a high-flow washable synthetic media filter element that does not require oiling and a breather system that routes gasses and excess oil directly into the intake. Kit also includes cover trim and all mounting hardware. Street legal when used with stock mufflers. All models require ECM calibration\* (priced separately).

**29782-07**

Fits '07-later XL models with Original Equipment throttle body and stock oval air cleaner cover. XL1200V requires separate purchase of oval air cleaner cover P/N 29084-04DH.

\*Recalibration is required for proper installation. See Dealer for details.

## C. SCREAMIN' EAGLE SPORTSTER STAGE I AIR CLEANER KIT – ROUND

The XL Stage I Air Cleaner Kit provides increased airflow to boost the power of your fuel-injected Sportster model. Available with brilliant chrome or gloss black back plate, this Round Air Cleaner transforms the appearance of your Evolution power plant and allows you to replace the Original Equipment oval air cleaner cover with your choice of accessory round covers. Or choose to flaunt your performance gains with the open element look, finished with custom Air Cleaner Trim from one of the Harley-Davidson® decorative collections. Kit includes one-piece cast back plate, high-flow washable air filter element and all required hardware. Street legal when used with stock mufflers. Requires ECM calibration\* (priced separately).

Fits '07-later XL models with Original Equipment throttle body. Requires separate purchase of a round air cleaner cover or Twin Cam-style air cleaner trim. Air Cleaners P/N 29400-08, 29153-07, 29417-04, 61400007, 61400009, 61300057 and 27956-10 require separate purchase of Screw P/N 29269-83A. XL1200V requires separate purchase of Gasket P/N 25700127.

**29000019A** Chrome.

**29000009A** Black.

\*Recalibration is required for proper installation. See Dealer for details.



A. SCREAMIN' EAGLE PERFORMANCE AIR CLEANER FOR VRSC MODELS



B. SCREAMIN' EAGLE SPORTSTER STAGE I AIR CLEANER KIT – OVAL

### SPORTSTER 1200 STOCK VS. STAGE I AIR CLEANER & STREET CANNON MUFFLERS

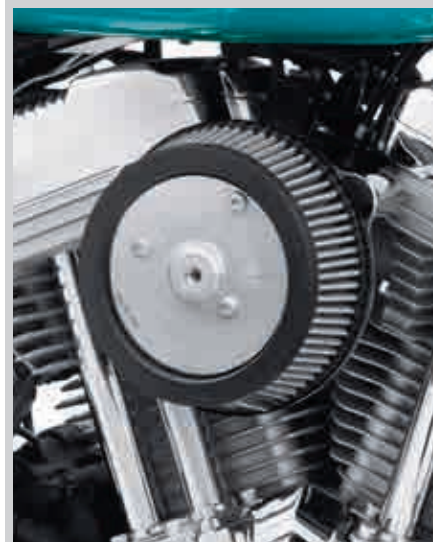
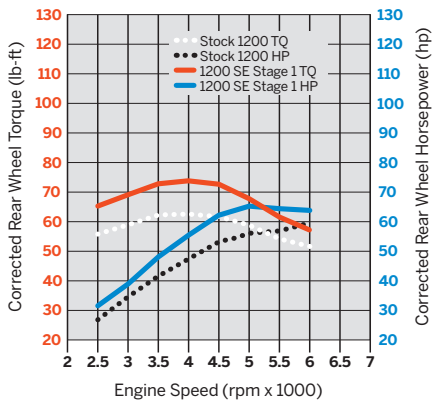

C. SCREAMIN' EAGLE SPORTSTER STAGE I AIR CLEANER KIT – ROUND

Not all products are available in all countries – please consult your dealer for details.

# SCREAMIN' EAGLE® 479

Air Cleaner Kits



**D. STAGE I AIR CLEANER KIT - CHROME**  
(29400234 SHOWN)



**NEW**

**D. STAGE I AIR CLEANER KIT - BLACK**  
(29400233 SHOWN)



**D. STAGE I AIR CLEANER KIT - BLACK**  
(29400239 SHOWN)



**NEW**

**D. STAGE I AIR CLEANER KIT - CHROME**  
(29400240 SHOWN)



**D. STAGE I AIR CLEANER KIT - BLACK**  
(29400235 SHOWN)



**NEW**

**D. STAGE I AIR CLEANER KIT - CHROME**  
(29400236 SHOWN)



**D. STAGE I AIR CLEANER KIT - CHROME**  
(29400238 SHOWN)



**NEW**

**D. STAGE I AIR CLEANER KIT**  
(29400222 SHOWN)

## D. SCREAMIN' EAGLE® STAGE I AIR CLEANER KIT

The Stage I Air Cleaner Kit provides increased airflow to boost the power of your fuel-injected model. Kit features a one-piece cast back plate with integral breather and mounting brackets for simplified installation and a synthetic washable air cleaner element that does not require oiling. Available with a brilliant chrome or black back plate, this round air cleaner element can be dressed with most Original Equipment or accessory air cleaner covers. Or choose to flaunt your performance gains with the open element look, and finish it off with a Rain Sock Kit P/N 28728-10 and custom Air Cleaner Trim from one of the Harley-Davidson® decorative collections. This kit includes air cleaner, back plate, breather and all required hardware. Street legal when used with stock mufflers. All EFI-equipped models require ECM calibration\* (priced separately).

Fits '16-later Softail® and '14-later Touring and Trike models (except CVO™ Touring) with Original Equipment 50mm Throttle Body.

**29400234** Chrome.

**29400233** Texture Black.

Fits '08-'15 Softail models (except CVO Softail). Also fits '08-later Dyna® models equipped with accessory Air Cleaner Cover. Also fits '04-'07 EFI Dyna, '01-'07 EFI Softail, and '02-'07 EFI Touring. FXS, FLS, FLSTSB and '13-later FXDB models require separate purchase of Gasket P/N 29591-99 and Screw P/N 29703-00.

**29400240** Chrome.

**29400239** Texture Black.

Fits '08-later Dyna models with Original Equipment Teardrop Air Cleaner Cover.

**29400236** Chrome.

**29400235** Texture Black.

Fits '08-'13 Touring and Trike models (except CVO Touring) with Original Equipment 50mm throttle body.

**29400238** Chrome.

**29400237** Texture Black.

Fits '16-later Softail and '14-later Touring models equipped with Screamin' Eagle 58mm EFI Throttle Body. Requires separate purchase of an Accessory Air Cleaner Cover.

**29400222** Raw Aluminium.

## TWIN CAM 103 HO STOCK VS. 103 HO STAGE I

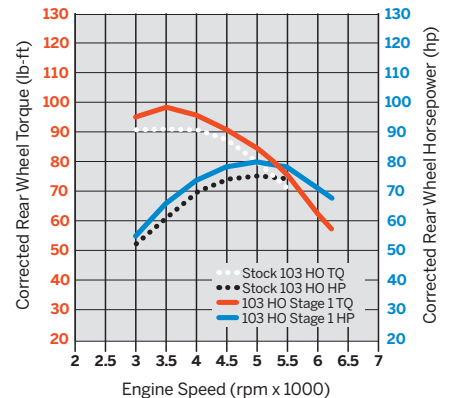

Not all products are available in all countries – please consult your dealer for details.

# 480 SCREAMIN' EAGLE®

Air Cleaner Kits

## A. SCREAMIN' EAGLE® AIR CLEANER INSERT

Dress your factory air cleaner cover with a diamond cut Screamin' Eagle® medallion. Lock patch holds the medallion firmly in place and is easy to remove for access to the air cleaner hardware.

**61300299**

Fits '16-later Softail® (except FLSTFBS) and '14-later Touring and Trike models with Original Equipment air cleaner cover. Does not fit CVO™ models.

## B. SCREAMIN' EAGLE AIR CLEANER TRIM RING

Dress your air cleaner in the traditional H-D® orange and black. Easy-to-install trim ring features brilliant orange Screamin' Eagle script and Harley-Davidson lettering set against a gloss black background. Self adhesive backing.

**29503-07**

Fits '07 Dyna®, '07-'15 Softail (except FLSTSB and FXS), '07-'13 Touring and Trike models models with Original Equipment air cleaner cover.

## C. SCREAMIN' EAGLE AIR CLEANER RAIN SOCK

Add the open-element look to your Screamin' Eagle Stage-style Air Cleaner. This easy-to-install kit allows you to replace the traditional Original Equipment air cleaner cover with custom inserts from one of the H-D Decorative Collections. Kit includes a breathable mesh cover with classic Bar & Shield logo that stretches over the filter to maximize airflow while protecting the exposed element from the rain. Fits traditional cone-shaped air cleaner elements featured in many Screamin' Eagle Twin Cam Stage Kits.

**28728-10**

Fits Screamin' Eagle Stage I Round Air Cleaner Kits.

## D. SCREAMIN' EAGLE AIR CLEANER BACK PLATE KITS

Finished in brilliant chrome or wrinkle black, these replacement back plates complement the finish of your engine. Cast back plate design features integral breather and mounting brackets for simplified installation.

Fits models equipped with Screamin' Eagle Stage Kits or High-Flow Air Cleaner Kits. Installation may require separate purchase of (2) O-Ring P/N 11292, (2) Breather Tube P/N 29557-05 and (2) Breather Screw P/N 29465-99. See your Dealer for details.

Fits '99-'07 Dyna, '99-'15 Softail (except '11-later CVO) and '02-'07 Touring models.

**29510-05** Chrome.

**29586-06** Wrinkle Black.

Fits '08-'13 Touring and Trike models.

**29624-08** Chrome.

**29319-08** Wrinkle Black.

Fits '08-later Dyna models with Original Equipment Teardrop Air Cleaner Cover.

**29170-08** Chrome.

**29119-08** Wrinkle Black.



A. SCREAMIN' EAGLE AIR CLEANER INSERT



B. SCREAMIN' EAGLE AIR CLEANER TRIM RING



C. SCREAMIN' EAGLE AIR CLEANER RAIN SOCK (SHOWN WITH #1 SKULL AIR CLEANER TRIM)



Multi-Fit

'08-'13 Touring

'08-later Dyna

D. SCREAMIN' EAGLE AIR CLEANER BACK PLATE KITS

Not all products are available in all countries – please consult your dealer for details.

# SCREAMIN' EAGLE® 481

Air Cleaner Kits

## E. SCREAMIN' EAGLE® HIGH-FLO K&N® AIR FILTER ELEMENT

K&N® replacement air filters are engineered to improve airflow for increased horsepower and quicker acceleration. K&N filters provide excellent filtration and because they are washable and reusable, you can clean the filter whenever conditions demand. Designed as direct replacements for specified fitments.

**NOTE:** These washable and rechargeable filters use a special coating to help filter fine particles from the incoming air. With time, the oil in the filter will dissipate and the element will begin to turn gray. Clean the surface and renew the original red color with an application of K&N Air Filter Care products.

- 1. 29400020** Stage I-Multi-fit.  
Fits '07-later XL, '99-'07 Dyna®, '00-'15 Softail® and '99-'07 Touring models equipped with Stage I Air Cleaner Kit. Replacement for P/N 29442-99E.
- 2. 29400021** Stage I-Dyna.  
Fits '08-later Dyna models equipped with Stage I Air Cleaner Kit. Replacement for P/N 29385-08.
- 3. 29400019** Stage I-Touring.  
Fits '16-later Softail and '08-later Touring and Trike models equipped with Stage I Air Cleaner Kit. Replacement for P/N 29244-08.
- 4. 29400065** Extreme Billet.  
Fits '15-later XG, '16-later Softail and '08-later Touring and Trike models equipped with Extreme Billet Agitator and Chisel Air Cleaner Kits.
- 4. 29400118** Extreme Billet.  
Fits '07-later XL, '08-later Dyna and '08-'15 Softail models equipped with Extreme Billet Chisel Air Cleaner Kits.
- 5. 29400109** Burst Collection.  
Fits '08-later Dyna, Softail, Touring and Trike models equipped with Burst Collection Air Cleaner Kits.
- 6. 29400026** Stage I-XL.  
Fits '88-later XL models equipped with High-Flow Air Cleaner Kit P/N 29042-04C or 29066-03B. Replacement for P/N 29044-04B.
- 7. 29400022A** Ventilator-Multi-fit.  
Fits models equipped with Ventilator and Extreme Billet Ventilator Performance Air Cleaner Kits. Replacement for P/N 29670-09.
- 8. 29424-05A** Heavy Breather-Multi-fit.  
Fits models equipped with Heavy Breather Kit P/N 29098-09, 29299-08, 29080-09 or 29264-08.
- 8. 29702-08A** Heavy Breather-Touring.  
Fits models equipped with Heavy Breather Kit P/N 29006-09B, 29253-08B, 29000065 or 29400105.
- 9. 28714-10** Heavy Breather-Compact.  
Fits '08-later Touring and Trike models equipped with Compact Heavy Breather Kit P/N 28716-10A.
- 10. 29400141** Heavy Breather-Elite.  
Fits models equipped with Screamin' Eagle® Heavy Breather Elite Performance Air Cleaner Kit P/N 29400172 and 29400173.

E. SCREAMIN' EAGLE HIGH-FLO K&N AIR FILTER ELEMENT

## F. K&N AIR FILTER CARE PRODUCTS

Clean and restore the original performance of K&N air filter elements. The washable and rechargeable filters use a special coating to help filter fine particles from the incoming air. With time, the oil in the filter will dissipate and the element will begin to turn gray. Clean the surface and renew the original red color with an application of K&N Air Filter Care products.

### K&N AIR FILTER CARE SERVICE KIT

**99850-92T**

Complete kit to clean and re-oil K&N-type air filters. Includes one 12 oz bottle Air Filter Cleaner and one aerosol Air Filter Oil.

### K&N AIR FILTER OIL

**99882-88T** 12 oz Aerosol.

### K&N POWER KLEEN AIR FILTER CLEANER

Works well with K&N or dry synthetic Screamin' Eagle air filters.

**93600004** 32 oz with Sprayer.



F. K&N AIR FILTER CARE SERVICE KIT



F. K&N AIR FILTER OIL



F. K&N POWER KLEEN AIR FILTER CLEANER

Not all products are available in all countries - please consult your dealer for details.



## 482 SCREAMIN' EAGLE®

SCREAMIN' EAGLE  
STREET CANNON  
MUFFLER

SHORT SLASH  
END CAPS

*Screamin' Eagle*

## MORE THAN JUST HOT AIR

The sound of a Harley-Davidson® motorcycle grabs the heart and moves the soul. The complete line of Screamin' Eagle® Street Performance Mufflers is tuned to enhance the bass notes and deliver a rich melodic tone from idle to wide-open throttle. These stylish slip-on mufflers produce real-world performance improvements, while maintaining EPA-approved sound levels.

### POWER VS. NOISE

A loud exhaust system doesn't mean improved performance. Screamin' Eagle® Street Performance Mufflers are designed to significantly increase airflow and add torque and horsepower you can feel with a twist of the throttle. Engineered to deliver where it counts — during a roll-on pass or on a long run up a steep grade — all street-legal Harley-Davidson® exhaust systems carry the EPA stamp.

**The "Room"** — a silent chamber lined with perforated sheet metal and 50,000 pounds of fiberglass acoustic wedges — uses a wide array of microphones to get precise readings of drive-by noise. This is the room that creates that world-famous Harley-Davidson sound.



*Not all products are available in all countries –  
please consult your dealer for details.*

# SCREAMIN' EAGLE® 483

Sportster® Exhaust

## A. SCREAMIN' EAGLE® STREET CANNON SLIP-ON MUFFLERS – SPORTSTER® SHORTY DUAL

These 3.25" street legal high-flow mufflers have been specifically tuned to deliver an aggressive exhaust note and improved performance while preserving the peace with your neighbors. Available in your choice of rich chrome or heat resistant jet black ceramic finish. EPA stamped. Complete the look with your choice of 3.25" endcaps and Screamin' Eagle® Muffler shields (sold separately).

Fits '14-later XL models. Designed for international markets that require ECE Certified mufflers. Mufflers include muffler shields and slash down end caps. Installation requires separate purchase of Muffler Clamps P/N 65296-95A (Qty 2).

**64900325** Chrome.

**64900322** Jet Black.



**A. SCREAMIN' EAGLE STREET CANNON SLIP-ON MUFFLERS –  
SPORTSTER SHORTY DUAL, CHROME  
(SHOWN WITH CHROME SLASH END CAPS)**



**A. SCREAMIN' EAGLE STREET CANNON SLIP-ON MUFFLERS –  
SPORTSTER SHORTY DUAL, JET BLACK  
(SHOWN WITH JET BLACK SLASH END CAPS AND MUFFLER SHIELDS)**

# 484 SCREAMIN' EAGLE®

Sportster® Exhaust

## A. SCREAMIN' EAGLE END CAPS – 3.25"

These easy-to-install caps allow you to finish your 3.25" Screamin' Eagle mufflers your way. Sold in pairs. Installation hardware included.

Fits '14-later XL and '07-later Softail® models equipped with Screamin' Eagle 3.25" Street Cannon Mufflers.

**65100049** Billet Chrome Slash Cut.

**65100048** Satin Black Anodized.

**65100044** Chrome – Slash Up/Down/Out.

**65100063** Jet Black – Slash Up/Down/Out.

## B. SCREAMIN' EAGLE® JET BLACK HEADER PIPES

Hide the blue. These Original Equipment-style Header Pipes have been finished with a unique jet black heat resistant coating and are a great accent to both chrome and black Buckshot exhaust shields. When exposed through the holes in the Buckshot shields, the black header pipe provides a sinister accent and hides the heat-tempered finish of the typical exhaust pipe. Easy to install using factory mounting hardware, the kit includes front and rear header pipe.

**65600155**

Fits '14-later XL models.

**80887-10**

Fits '04-'13 XL models.



A. SCREAMIN' EAGLE END CAPS – 3.25"

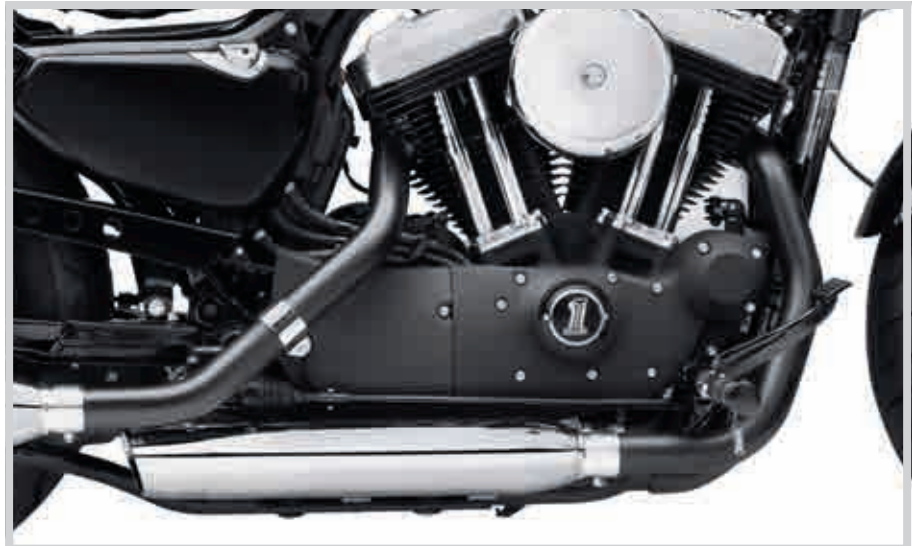

B. SCREAMIN' EAGLE JET BLACK HEADER PIPES (65600155 SHOWN)



B. SCREAMIN' EAGLE JET BLACK HEADER PIPES (65600155 SHOWN)



B. SCREAMIN' EAGLE JET BLACK HEADER PIPES (80887-10 SHOWN)

*Not all products are available in all countries – please consult your dealer for details.*

# SCREAMIN' EAGLE® 485

Sportster® Exhaust

## C. SCREAMIN' EAGLE BUCKSHOT EXHAUST SHIELD KIT

These custom shields feature a perforated "Buckshot" design that exposes the head pipe for a raw, rebellious look. Available in your choice of finishes, these exhaust shields are a perfect match for Original Equipment or Screamin' Eagle® mufflers and provide a consistent look from front to back. Manufactured to Original Equipment standards for exacting fit, the easy-to-install kit includes front and rear head pipe shields.

Fits '14-later XL models.

**65400137** Jet Black.

**65400143** Chrome.

Fits '04-'13 XL models.

**64924-09** Jet Black.

## D. SCREAMIN' EAGLE MUFFLER SHIELDS

Styled to complement the ballistic inlet shape of the Screamin' Eagle Street Performance Slip-On Mufflers. The rear shield features a deep embossed "Screamin' Eagle" signature script. Available in chrome and jet black. Easy-to-install kit includes front and rear shields and mounting hardware.

Fits '07-later XL, Dyna® (except '08-later FLD, FXDF, FXDL and '10-later FXDWG) and Softail® models equipped with Screamin' Eagle Street Performance Mufflers.

**64806-07A** Chrome.

**65400078** Jet Black.



C. SCREAMIN' EAGLE BUCKSHOT EXHAUST SHIELD KIT – JET BLACK (65400137 SHOWN)



C. SCREAMIN' EAGLE BUCKSHOT EXHAUST SHIELD KIT – CHROME (65400143 SHOWN)



C. SCREAMIN' EAGLE BUCKSHOT EXHAUST SHIELD KIT – JET BLACK (64924-09 SHOWN)



D. SCREAMIN' EAGLE MUFFLER SHIELDS

NOTE: Due to increased diameter of these mufflers some realignment of head pipes is usually required. It is recommended to replace exhaust port gaskets, P/N 65324-83A (stock) or P/N 17048-98 (performance), to avoid tendency of head pipes to return to original position when re-tightened.

NOTE: There is no warranty on exhaust pipes and mufflers with regard to any discoloration. Blueing is caused by tuning characteristics, cam timing, carburetor jetting, over-heating, etc. and is not caused by defective manufacturing.

Not all products are available in all countries – please consult your dealer for details.

# 486 SCREAMIN' EAGLE®

Dyna® Exhaust

## A. SCREAMIN' EAGLE® EXHAUST SHIELD KIT – DYNA® SHORTY DUAL

Extend the custom look along the bike's entire profile. These formed steel exhaust shields are available in a unique jet black ceramic finish that complements jet black Screamin' Eagle® Street Performance Slip-On Mufflers. This exhaust shield kit has survived stringent Harley-Davidson testing for durability and corrosion resistance. Manufactured to Original Equipment standards for exact fit, the easy-to-install kit includes front and rear head pipe shields.

**80821-10** Jet Black.

Fits '06-'10 FXD, '06-later FXDB, '06-'14 FXDC, '06-'13 FXDL and '06-'08 FXDWG models with shorty dual exhaust.



A. SCREAMIN' EAGLE EXHAUST SHIELD KIT – DYNA SHORTY DUAL



B. SCREAMIN' EAGLE EXHAUST SHIELD KIT – DYNA STAGGERED DUAL

## B. SCREAMIN' EAGLE EXHAUST SHIELD KIT – DYNA STAGGERED DUAL

Add a custom touch to your ride. These formed steel exhaust shields are available in a tough jet black ceramic that looks just right when paired with jet black Screamin' Eagle Street Performance Slip-On Mufflers. The jet-black coating adds a sinister look to your bike's profile. The slotted "tommy gun" cutouts expose the head pipe for a raw, rebellious attitude. Manufactured to Original Equipment standards for exact fit, this easy-to-install kit includes front and rear head pipe shields.

**65247-09** Jet Black.

Fits '08-later FXDF and '10-later FXDWG models with forward controls.

## C. SCREAMIN' EAGLE EXHAUST SHIELD KIT – DYNA 2-INTO-1

Extend the blacked-out look along the bike's entire profile. These formed steel exhaust shields feature a unique jet black ceramic coating that complements the jet black Screamin' Eagle Street Performance Slip-On Mufflers. The jet black coating maintains its uniform black finish and has survived stringent Harley-Davidson testing for durability and corrosion resistance. Manufactured to Original Equipment standards for exacting fit, the easy-to-install kit includes front and rear head pipe shields.

**65400088** Jet Black.

Fits '12-later FLD models.

**65400172** Jet Black.

Fits '14-later FXDL models equipped with Nightstick Muffler P/N 64900242 or 64900243.

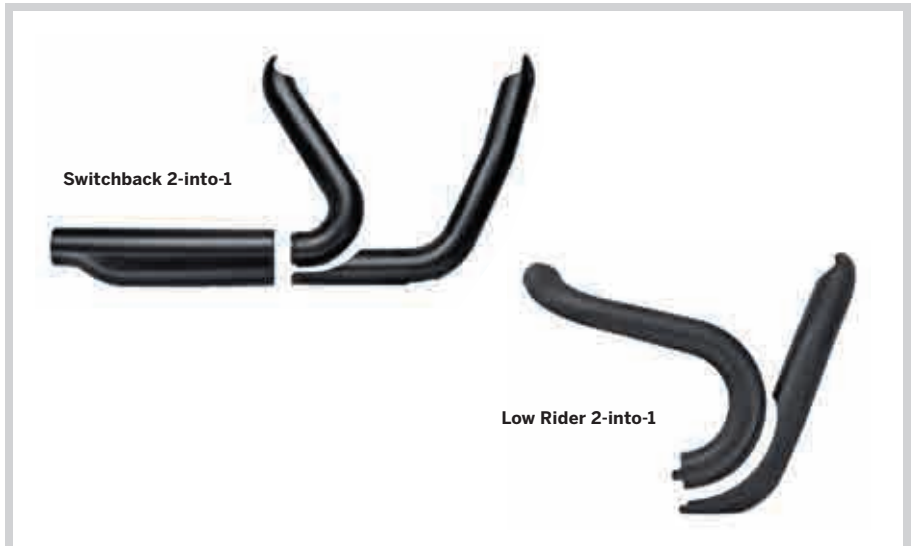

C. SCREAMIN' EAGLE EXHAUST SHIELD KIT

## D. SCREAMIN' EAGLE MUFFLER SHIELDS

Styled to complement the ballistic inlet shape of the Screamin' Eagle Street Performance Slip-On Mufflers. The rear shield features a deep embossed "Screamin' Eagle" signature script. Available in chrome and jet black. Easy-to-install kit includes front and rear shields and mounting hardware.

Fits '07-later XL, Dyna® (except '08-later FLD, FXDF, FXDL and '10-later FXDWG) and Softail® models equipped with Screamin' Eagle Street Performance Mufflers.

**64806-07A** Chrome.

**65400078** Jet Black.



D. SCREAMIN' EAGLE MUFFLER SHIELDS

NOTE: There is no warranty on exhaust pipes and mufflers with regard to any discoloration. Blueing is caused by tuning characteristics, cam timing, carburetor jetting, over-heating, etc. and is not caused by defective manufacturing.

Not all products are available in all countries – please consult your dealer for details.

# SCREAMIN' EAGLE® 487

Softail® Exhaust

## E. SCREAMIN' EAGLE EXHAUST SHIELD KIT – SOFTAIL®

Extend the blacked-out look along the bike's entire profile. These formed steel exhaust shields feature a unique jet black ceramic coating that complements the jet black Screamin' Eagle® Street Performance Slip-On Mufflers. The jet black coating maintains its uniform black finish and has survived stringent Harley-Davidson testing for durability and corrosion resistance. Manufactured to Original Equipment standards for exacting fit, the easy-to-install kit includes front and rear head pipe shields.

### 1. 80817-10A Jet Black.

Fits '07-later FLSTF, FLSTFB and FLSTFBS, '11-'13 FXS and '07 FXSTD models equipped with shotgun exhaust.

### 2. 80829-10A Jet Black.

Fits '07-later FLS, FLSS, FLSTSB and FLSTN models.

### 3. 80818-10 Jet Black.

Fits '08-'11 FXCW and FXCWC, '13-later FXSB and '13-'14 FXSBSE models equipped with shorty dual exhaust.



E. SCREAMIN' EAGLE EXHAUST SHIELD KIT – SOFTAIL

NOTE: There is no warranty on exhaust pipes and mufflers with regard to any discoloration. Blueing is caused by tuning characteristics, cam timing, carburetor jetting, over-heating, etc. and is not caused by defective manufacturing.

Not all products are available in all countries – please consult your dealer for details.

# 488 SCREAMIN' EAGLE®

Touring Exhaust

## A. SCREAMIN' EAGLE® LASER EXHAUST SHIELD KIT

Show-winning style. This kit replaces the factory exhaust shields with a unique and attention-getting design. The shields feature laser cut openings that are filled with tightly-woven mesh that delivers a modern high performance look. Available in chrome or jet black ceramic, the finish is a perfect match for Original Equipment or Screamin' Eagle® mufflers. The easy-to-install kits include front and rear header shield and collector shield.

Fits '09-later Touring and Trike models (except '10 FLHX and FLTRX).

**65400064** Chrome with Chrome Screens.

**65400117** Jet Black with Stainless Steel Screens.



A. SCREAMIN' EAGLE LASER EXHAUST SHIELD KIT – CHROME WITH CHROME SCREENS

## B. SCREAMIN' EAGLE EXHAUST SHIELD KIT – TOURING

Available for 2-into-1 and 2-into-2 exhaust systems, these formed steel exhaust shields feature a unique jet black ceramic coating that complements the jet black Screamin' Eagle Street Performance Slip-On Mufflers. The jet black coating maintains its uniform black finish and has survived stringent Harley-Davidson testing for durability and corrosion resistance. Manufactured to Original Equipment standards for exacting fit, the easy-to-install kit includes front and rear head pipe shields.

**1. 64981-09** Jet Black 2-into-2 Exhaust.

Fits '09-later Touring and Trike models (except '10 FLHX and FLTRX).

**2. 66906-10** Jet Black 2-into-1 Exhaust.

Fits '10 FLHX and FLTRX models with Original Equipment 2-into-1 exhaust.



A. SCREAMIN' EAGLE LASER EXHAUST SHIELD KIT – CHROME WITH CHROME SCREENS



A. SCREAMIN' EAGLE LASER EXHAUST SHIELD KIT

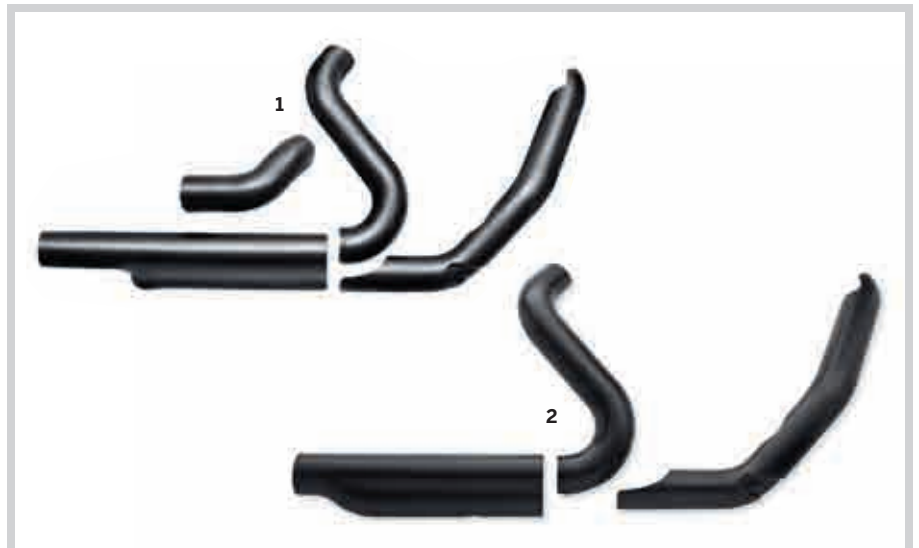

B. SCREAMIN' EAGLE EXHAUST SHIELD KIT – TOURING

*Not all products are available in all countries – please consult your dealer for details.*

## STAGE KITS

Screamin' Eagle® EFI Stage Kits offer complete street-legal performance configurations engineered to help you generate specific torque and horsepower gains. Eliminating all the guesswork and trial-and-error testing normally associated with engine modifications, Stage Kits include everything you need to enhance your bike's performance, including big-bore cylinders, high-compression pistons, performance cams and high-flow air cleaners.

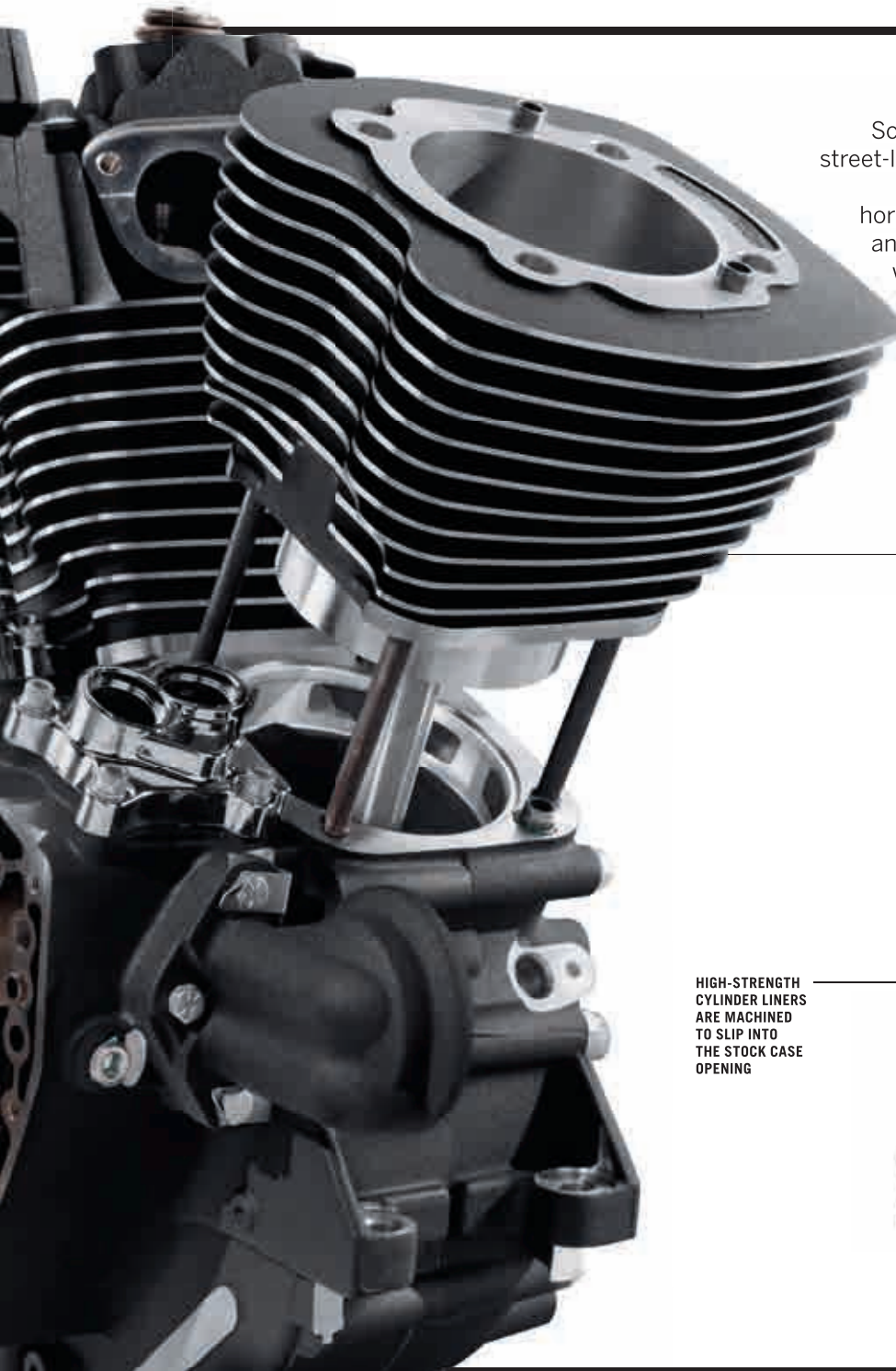

BOLT-ON  
TWIN-CAM 110™  
BIG BORE  
STAGE KITS

HIGH-STRENGTH  
CYLINDER LINERS  
ARE MACHINED  
TO SLIP INTO  
THE STOCK CASE  
OPENING



### WARRANTY & CAUTION

#### OVERVIEW

Harley-Davidson has the engineering expertise, sophisticated dyno lab and complete testing facilities to provide enthusiasts with a line of performance products designed to produce good, solid, reliable horsepower and torque. Engine-related performance parts are intended for the experienced rider only.

#### WARRANTY

Installation of Screamin' Eagle products and similar off-road or competition products from other manufacturers, except some street-legal offerings installed by authorized Harley® dealers, may void your H-D® limited vehicle warranty.

#### CAUTION

Harley-Davidson motorcycles modified with some Screamin' Eagle high-performance engine parts must not be used on public roads and in some cases may be restricted to closed-course competition.

*Not all products are available in all countries – please consult your dealer for details.*



# 490 SCREAMIN' EAGLE®

Street Performance Crate Motor

## A. SCREAMIN' EAGLE® SE120ST STREET PERFORMANCE CRATE MOTOR

This street-tuned 120 cubic inch Screamin' Eagle® Crate Motor takes your bagger from mild to wild. This engine is designed for bolt-in installation in the Original Equipment-style chassis of your Touring bike. No special fabrication or engine mount relocation is required. The crankcase, cylinders and heads are painted black, and feature machined aluminum highlights and chrome covers for a stunning "show-and-go" look. Equipped with the ultimate large bore Screamin' Eagle 58mm Throttle Body (18% larger than stock), this engine is capable of producing 106 horsepower and 117 lb-ft of torque at the rear wheel. Engine retains the Original Equipment vehicle warranty. For best performance results, we recommend combining this engine with your choice of Screamin' Eagle 58mm High-Flow Air Cleaner and the Screamin' Eagle High Flow Exhaust System P/N 64800022.

This engine is street-legal when used with Original Equipment mufflers or the Screamin' Eagle Street Performance Exhaust System P/N 64800022. All EFI-equipped models require ECM calibration\* (priced separately). U.S. delivered engines include Manufacturer's Statement of Origin (MSO).

Developed and tested in Milwaukee, this motor features the finest Screamin' Eagle components:

- 4.060 big-bore cylinders.
- 4-5/8" stroke SE Pro stroker flywheel and rod assembly.
- 10.5:1 high-compression nickel-plated forged pistons with Teflon® coated skirt.
- Titanium SST piston rings.
- SE-259E high-lift cams.
- Perfect-Fit pushrods.
- SE high-performance lifters.
- CNC-ported MVA heads with automatic compression release.
- Screamin' Eagle Pro High-Flow 58mm EFI Throttle Body, high flow injectors and manifold clamps.
- Machined lower rocker boxes for valve spring collar clearance.
- Factory-machined engine cases.
- Unique piston oilers for stroker clearance.
- Screamin' Eagle inner crankcase full complement cam needle bearings.
- SE Lefty high-performance crankcase output bearing and nitride bearing race.
- SE Performance spark plugs.
- 120ST cam cover and cylinder head medallions.

### 19221-15

Fits '15 Touring models. Does not fit models with Twin-Cooled™ engines. Model year '10-'14 50-state and model year '16 50-state certification pending regulatory approval.

\*Recalibration is required for proper installation. See Dealer for details. Labor cost not included.



Twin Cam 103HO Stock vs. ST120 Crate Motor

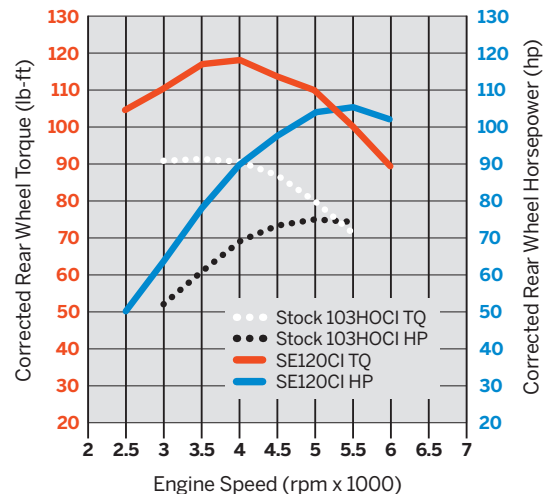

## A. SCREAMIN' EAGLE SE120ST STREET PERFORMANCE CRATE MOTOR

Not all products are available in all countries – please consult your dealer for details.

NEW

# SCREAMIN' EAGLE® 491

Twin Cam Stage Kits

## SCREAMIN' EAGLE® BOLT-ON 110CI STAGE V TIRE SHREDDER KIT

This comprehensive kit provides a complete package of matched components that allow you to build a high performance 110ci Twin Cam without voiding the factory warranty. The unique Screamin' Eagle® 4.0" big bore cylinders are engineered to slip into the engine cases without case machining or modification, so the engine stays in the chassis during the build.

Kit includes:

- Screamin' Eagle 4.0" Bolt-On Cylinders
- Forged 10.2:1 High Compression Pistons and Rings
- Screamin' Eagle 58mm Throttle Body
- High Flow Fuel Injectors
- Screamin' Eagle CNC-Ported Cylinder Heads
- SE-259 Cams
- Perfect-Fit Pushrods
- Screamin' Eagle High-Capacity Roller Tappets
- Top End and Cam Cover Gaskets
- Heavy Duty Clutch Spring

All EFI-equipped models require dealer-installed ECM calibration download or use of the tunable Screamin' Eagle Street Tuner Kit (priced separately)\*.

### 92500038

Fits '14-later Touring models, Does not fit Twin-Cooled™ models. Does not fit Trike models, CVO™ 110 models or models with engine cases that have been machined to accept large-bore cylinders. Requires separate purchase of accessory 58mm air cleaner and Cam Drive Retention Kit P/N 25566-06. Cam Spacer Kit P/N 25928-06 is recommended.

\*Recalibration is required for proper installation, See Dealer for details. Labor cost not included.

When installed by an authorized Harley-Davidson® Dealer at the time of vehicle delivery, these kits do not impact the vehicle's limited warranty.



Twin Cam 103HO Stock vs. 110CI Stage V Kit

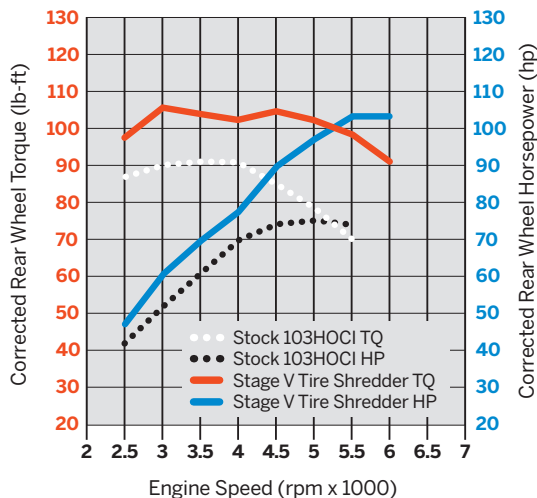

## SCREAMIN' EAGLE BOLT-ON 110CI STAGE V TIRE SHREDDER KIT

Not all products are available in all countries – please consult your dealer for details.

# 492 SCREAMIN' EAGLE®

Twin Cam Stage Kits

**NEW**

## SCREAMIN' EAGLE® BOLT-ON 110 CUBIC INCH STREET PERFORMANCE KIT

Bring your Twin Cam motorcycle up to the same 110 cubic inch displacement and power output as the CVO™ Screamin' Eagle® models without extensive machining or removing the engine from the chassis. This street legal kit combines the proven SE-255 cams and cylinder heads of the CVO model with exclusive Screamin' Eagle bolt-on 4.0" cylinders and system-matched pistons to deliver high torque and reliable everyday performance. The automatic compression release-equipped cylinder heads and the flat top forged pistons combine to develop a 9.3:1 compression ratio for easy starting, and the Screamin' Eagle lifters ensure quiet reliable valve train operation.

Kit includes:

- Screamin' Eagle 4.0" Bolt-On Cylinders
- Forged 9.3:1 Compression Pistons and Rings
- CVO 110 Cylinder Heads
- SE-255 Cams
- High-Capacity Roller Tappets
- Top End and Cam Cover Gaskets
- Heavy Duty Clutch Spring
- Cam Spacer Kit P/N 25928-06 is recommended

Requires separate purchase of appropriate Automatic Compression Release Wiring Harness. All EFI-equipped models require dealer-installed ECM calibration download or use of the tunable Screamin' Eagle Street Tuner Kit\* (priced separately).

**92500031** Black Highlighted.  
Fits 50-state '10-later Touring models (except '14-later models with Twin-Cooled™ engines). Does not fit Trike models, CVO™ 110 models, or models with engine cases that have been machined to accept large bore cylinders. Requires separate purchase of Screamin' Eagle high-flow air cleaner. '10 FLHX and FLTRX models require separate purchase of 2-into-2 Head Pipe Kit and Mufflers. '11-later Touring models require installation of CVO Mufflers P/N 64768-09A and 64769-09A (sold separately). '10-'11 Touring models require ACR Harness P/N 70623-08.

**92500032** Black Highlighted.  
Fits 50-state '14-later FLHTCU, FLHTCUL, FLHTK, FLHTKL and FLTRU models with Twin-Cooled engines. Does not fit Trike models, CVO 110 models, or models with engine cases that have been machined to accept large bore cylinders. Requires separate purchase of Screamin' Eagle high-flow air cleaner.

**92500033** Black Highlighted.  
Fits 50-state '11-later Dyna® FXD, FXDB and FXDC models equipped with Shorty Dual Exhaust. Installation requires separate purchase of Muffler P/N 64895-09 (Qty 2). Also fits 50-state '10-later FXDF and FXDWG models. FXDF and FXDWG models requires separate purchase of Mufflers P/N 65884-09 and 65886-09. All Dyna models require separate purchase of Screamin' Eagle high flow cleaner. '10-'11 Dyna models require ACR Harness P/N 70623-06. Does not fit models with engine cases that have been machined to accept large-bore cylinders. 50-state '11-later Softail® models (except FLS, FLSS, FLSTFBS, FLSTN, FLSTSB, CVO 110 models or models with engine cases that have been machined to accept large-bore cylinders.). Requires separate purchase of Screamin' Eagle high flow air cleaner. '11 Softail models require ACR Harness P/N 70623-11.

\*Recalibration is required for proper installation, See Dealer for details. Labor cost not included.

When installed by an authorized Harley-Davidson® Dealer at the time of vehicle delivery, these kits do not impact the vehicle's limited warranty.



Twin Cam 103HO Stock vs. 110CI Stage I Kit

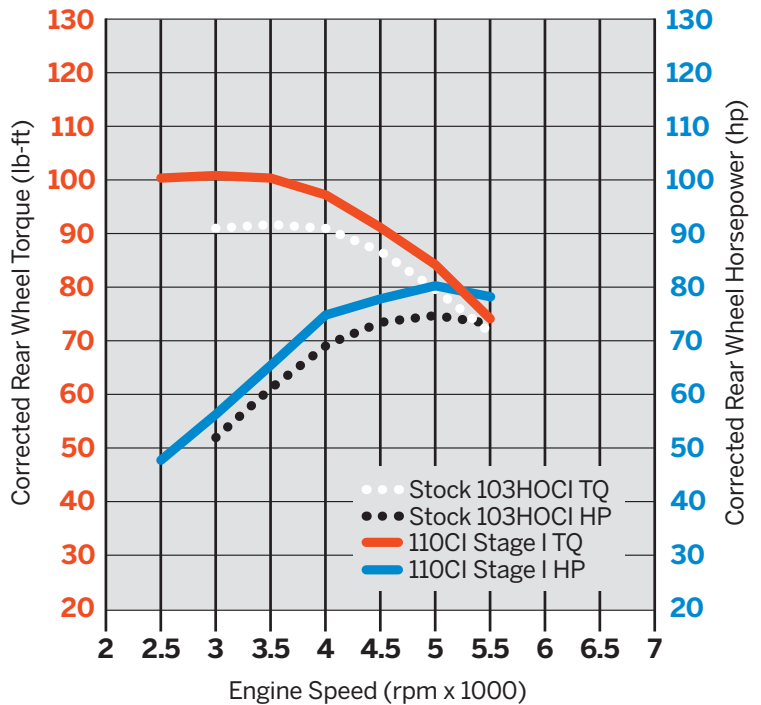

SCREAMIN' EAGLE BOLT-ON 110 CUBIC INCH STREET PERFORMANCE KIT

Not all products are available in all countries – please consult your dealer for details.

**NEW**

# SCREAMIN' EAGLE® 493

Twin Cam Stage Kits

## SCREAMIN' EAGLE® BOLT-ON 110 STAGE III STREET PERFORMANCE KIT

Build a fast, reliable 110 cubic inch Twin Cam hauler without having to remove the motor from the chassis. This Stage III Street Performance Kit combines system-matched Screamin' Eagle® big bore cylinders, high compression pistons and performance cams and valve train components with the Original Equipment cylinder heads for a cost-effective boost in torque and performance. The exclusive bolt-on 4.0" cylinders are engineered with high strength slim-wall spigots that slip into the factory crank case without any additional machining. The 4" flat top pistons team with the stock cylinder heads to produce a performance-enhancing 10.2:1 compression ratio (10.4:1 on Twin-Cooled™ models), and the high-lift SE-585 cam produces a boost in torque throughout the RPM range.

- Kit includes:
- Screamin' Eagle 4.0" Bolt-On Cylinders
- Forged 10.2:1 Compression Pistons and Rings
- SE-285 Cams
- High Performance Valve Springs
- Perfect-Fit Pushrods
- Screamin' Eagle High-Capacity Roller Tappets
- Top End and Cam Cover Gaskets
- Heavy Duty Clutch Spring

All EFI-equipped models require dealer-installed ECM calibration download or use of the tunable Screamin' Eagle Street Tuner Kit\* (priced separately).

**92500035** Black Highlighted.  
Fits '16-later Softail® and '14-later Touring models. Does not fit Trike models, FLSS, FLSTFBS, CVO™ 110 models or models with engine cases that have been machined to accept large-bore cylinders. Requires separate purchase of Cam Drive Retention Kit P/N 25566-06. Cam Spacer Kit P/N 25928-06 is recommended. Twin-Cooled models require separate purchase of model-specific head gaskets.

\*Recalibration is required for proper installation, See Dealer for details. Labor cost not included.



When installed by an authorized Harley-Davidson® Dealer at the time of vehicle delivery, these kits do not impact the vehicle's limited warranty.

**Twin Cam 103HO Stock vs. 110CI Stage III Kit**

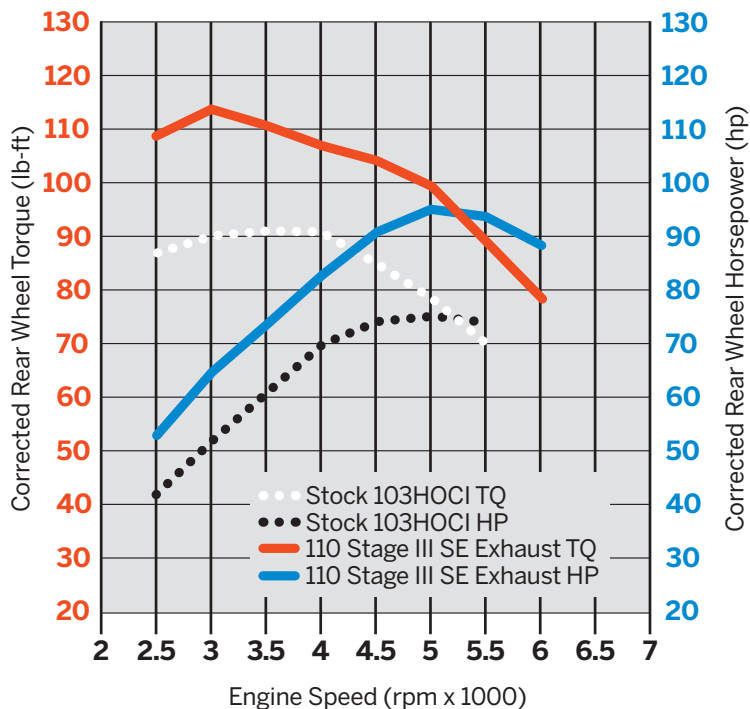

**SCREAMIN' EAGLE BOLT-ON 110 STAGE III STREET PERFORMANCE KIT**

Not all products are available in all countries – please consult your dealer for details.

# 494 SCREAMIN' EAGLE®

## Twin Cam Stage Kits

### SCREAMIN' EAGLE® STREET PERFORMANCE BIG BORE STAGE IV KIT – 103 CUBIC INCHES

This Street Performance kit provides the maximum horsepower output for a legal 103 Kit that will maintain the factory warranty.

Kit includes:

- Forged 10.5:1 High Compression Pistons and Rings
- Screamin' Eagle® 58mm Throttle Body
- Screamin' Eagle CNC Ported Cylinder Heads
- SE-259 Cams
- Perfect-Fit Pushrods
- Top End Gasket Kit
- Heavy Duty Clutch Spring

This Street Performance Kit produces 103 hp and 110 lbs-ft of torque. All EFI-equipped models require dealer-installed ECM calibration download or use of the tunable Screamin' Eagle Street Tuner Kit\* (priced separately).

**92500011** Black Highlighted.  
Fits 50-state '16-later Softail® (except FLSS and FLSTFBS) and '10-later Touring models (except '14-later models with Twin-Cooled™ engines) equipped with a Twin Cam 103™ engine. Fits 49-state '10-'11 Touring models equipped with a Twin Cam 96™ engine with separate purchase of Screamin' Eagle 3-7/8" Big Bore Cylinder Kit. '10 FLHX and FLTRX requires dual exhaust. Does not fit Trike models.

**92500019** Black Highlighted.  
Fits '14-later FLHTCU, FLHTCUL, FLHTK and FLHTKL models with Twin-Cooled engines. Does not fit Trike models.

\*Recalibration is required for proper installation. See Dealer for details. Labor cost is not included.

**NOTICE:** Installation of automatic or manual compression releases on large displacement engines is highly recommended.

When installed by an authorized Harley-Davidson® Dealer at the time of vehicle delivery, these kits do not impact the vehicle's limited warranty.



**Air Cooled**  
Twin Cam 103HO Stock vs. 103CI Stage IV Kit

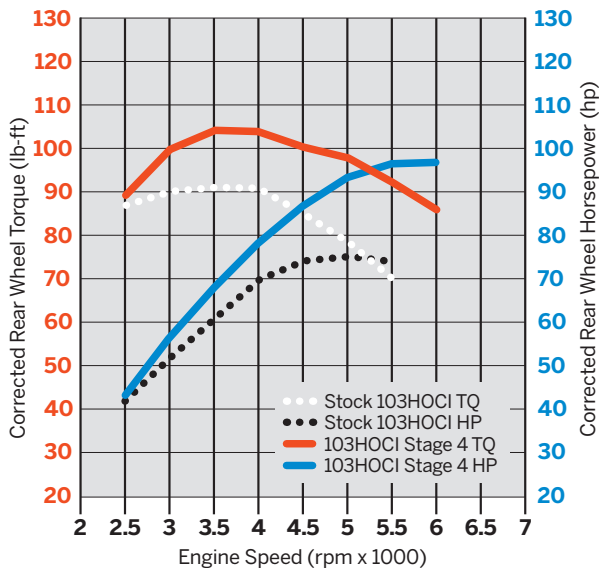

**Twin-Cooled™**  
Twin Cam 103HO Stock vs. 103CI Stage IV Kit

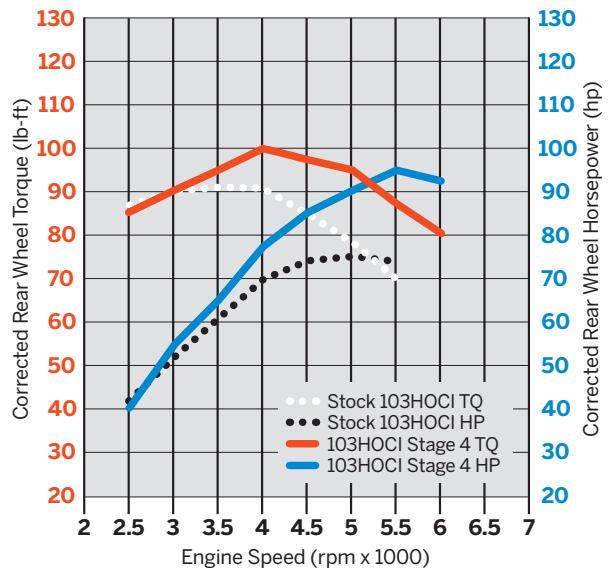

# SCREAMIN' EAGLE® 495

Twin Cam Stage Kits

## SCREAMIN' EAGLE® STAGE III KIT – 103 PERFORMANCE UPGRADE

Give your Touring bike the kick it needs to pass a road hogging RV on a long uphill climb. This street-legal Stage III "in-a-box" kit includes the system-matched components you need to build a performance Twin Cam engine with torque and horsepower characteristics you can use – every day. Designed for use with stock cylinder heads, this kit produces big torque gains at lower RPM while maintaining your factory warranty.

Kit includes:

- Forged 10.5:1 High Compression Pistons and Rings
- SE-585 Cams
- High Performance Valve Springs
- Perfect-Fit Pushrods
- Top End Gasket Kit
- Heavy Duty Clutch Spring

This street-performance engine has the potential to produce 88 HP and 100 lb-ft of torque with the stock cylinder heads. All EFI-equipped models require dealer-installed ECM calibration download or use of the tunable Screamin' Eagle® Street Tuner Kit\* (priced separately).

### 92500028

Fits '14-later Touring models. Does not fit Trike or models with Twin-Cooled™ engines. Requires separate purchase of outer primary cover gasket.

\*Recalibration is required for proper installation. See Dealer for details. Labor cost not included.

**NOTICE:** Installation of automatic or manual compression releases on large displacement engines is highly recommended.

When installed by an authorized Harley-Davidson® Dealer at the time of vehicle delivery, these kits do not impact the vehicle's limited warranty.



Twin Cam 103HO Stock vs. Twin Cam 103CI Stage III Kit

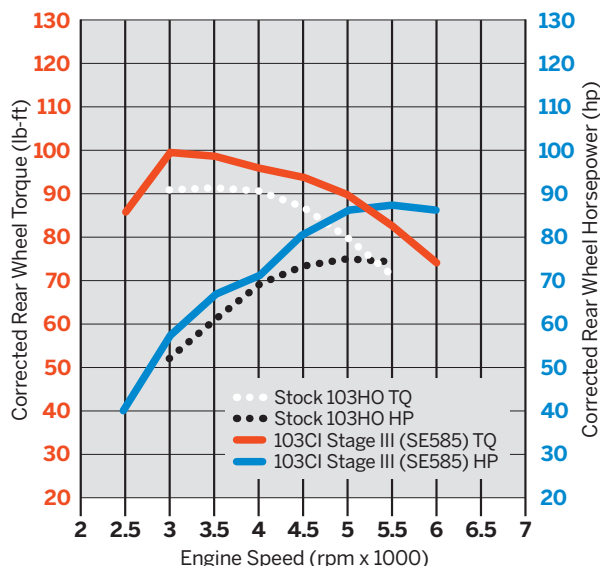

SCREAMIN' EAGLE STAGE III KIT – 103 PERFORMANCE UPGRADE

Not all products are available in all countries – please consult your dealer for details.

# 496 SCREAMIN' EAGLE®

## Twin Cam Stage Kits

### SCREAMIN' EAGLE® BIG BORE STAGE II KIT FOR EFI MODELS – 103 CUBIC INCHES\*

The Stage II Big Bore Kit provides the parts you need to increase the horsepower of your EFI-equipped model. The kit increases the displacement of your Twin Cam-equipped model from 96 cubic inches (1584cc) to 103 cubic inches (1690cc).

Kit includes:

- Big Bore Cylinders
- Big Bore Flat Top Pistons and Rings
- SE-255 Cams
- Stage I Air Cleaner Kit with One-Piece Back Plate
- Top End Gasket Kit
- Heavy Duty Clutch Spring

Also includes a high performance clutch spring. Separate purchase of cam spacers is recommended. Requires separate purchase of primary cover gasket. Not all components shown. All EFI-equipped models require dealer-installed ECM calibration download or use of the tunable Screamin' Eagle® Street Tuner Kit\* (priced separately).

**27543-08** Black Highlighted.  
Fits 50-state '10-later Softail® models equipped with a Twin Cam 96™ engine.

**27557-08** Black Highlighted.  
Fits 50-state '10-'11 Touring models equipped with Twin Cam 96 engine. '10 FLHX and FLTRX models require separate purchase of 2-into-2 Head Pipe and mufflers.

**27545-08** Black Highlighted.  
Fits 50-state '10-later Dyna® models equipped with a Twin Cam 96 engine.

**27564-09A** Black Highlighted.  
Fits 49-state '09 Touring models. Kit includes catalyst head pipe\*. Does not fit Trike models.

\*Recalibration is required for proper installation. See Dealer for details. Labor cost not included.

**NOTICE:** Installation of automatic or manual compression releases on large displacement engines is highly recommended.

When installed by an authorized Harley-Davidson® Dealer at the time of vehicle delivery, these kits do not impact the vehicle's limited warranty.



Twin Cam 96 Stock vs. 103CI Stage II Kit

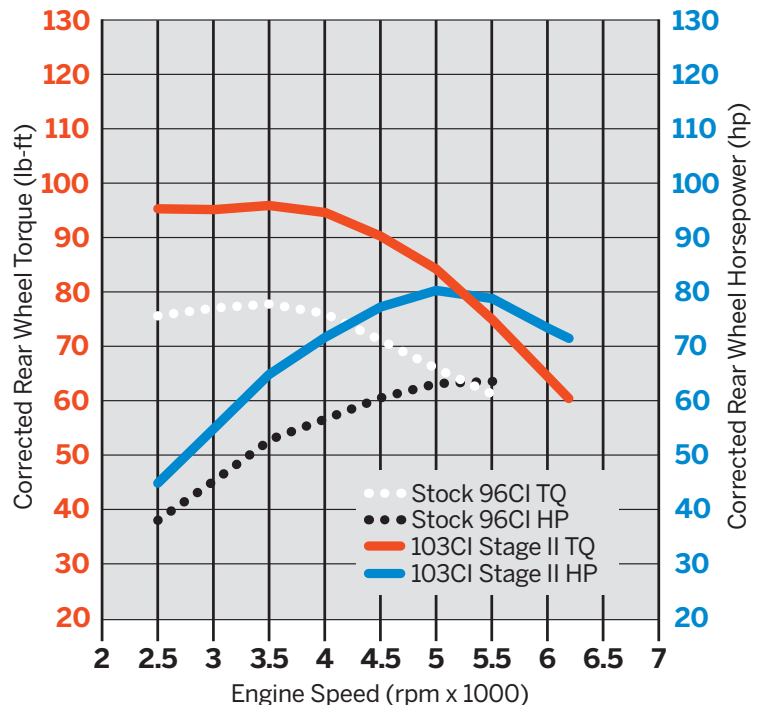

SCREAMIN' EAGLE BIG BORE STAGE II KIT FOR EFI MODELS – 103 CUBIC INCHES

Not all products are available in all countries – please consult your dealer for details.

# SCREAMIN' EAGLE® 497

Twin Cam Stage Kits

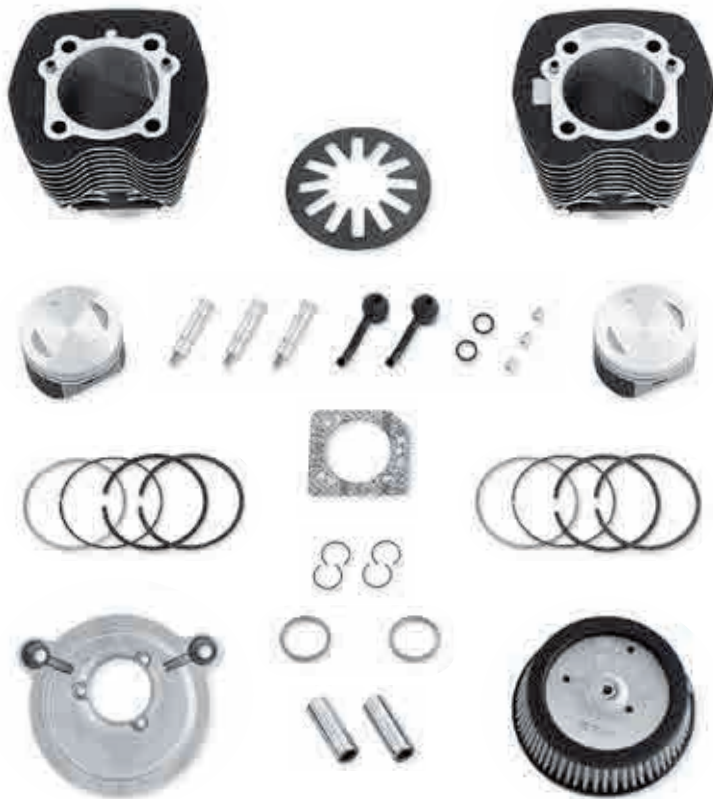

## SCREAMIN' EAGLE® BIG BORE STAGE I KIT FOR EFI MODELS – 103 CUBIC INCHES\*

This Big Bore Kit lets you increase the displacement of your Twin Cam 96™ engine-equipped model from 96 cubic inches (1584cc) to 103 cubic inches (1690cc).

Kit includes:

- Big Bore Cylinders
- Big Bore Flat Top Pistons and Rings
- Stage I Air Cleaner with One-Piece Back Plate
- Top End Gasket Kit
- Heavy Duty Clutch Spring

A high-performance clutch spring is included to provide the additional clutch capacity required by the extra torque. Requires separate purchase of primary cover gasket. This kit is street legal when used with stock mufflers. (Not all components shown.) All EFI-equipped models require dealer-installed ECM calibration download or use of the tunable Screamin' Eagle® Street Tuner Kit\* (priced separately).

**29903-07A** Black Highlighted.  
Fits all '07 Twin Cam and '08-later Softail® models equipped with a Twin Cam 96 engine.\*

**27539-08A** Black Highlighted.  
Fits '08-'11 Touring models equipped with a Twin Cam 96 engine.

\*Recalibration is required for proper installation. See Dealer for details. Labor cost not included.

**NOTICE:** Installation of automatic or manual compression releases on large displacement engines is highly recommended.

When installed by an authorized Harley-Davidson® Dealer at the time of vehicle delivery, these kits do not impact the vehicle's limited warranty.

Twin Cam 96 Stock vs. 103CI Stage I Kit

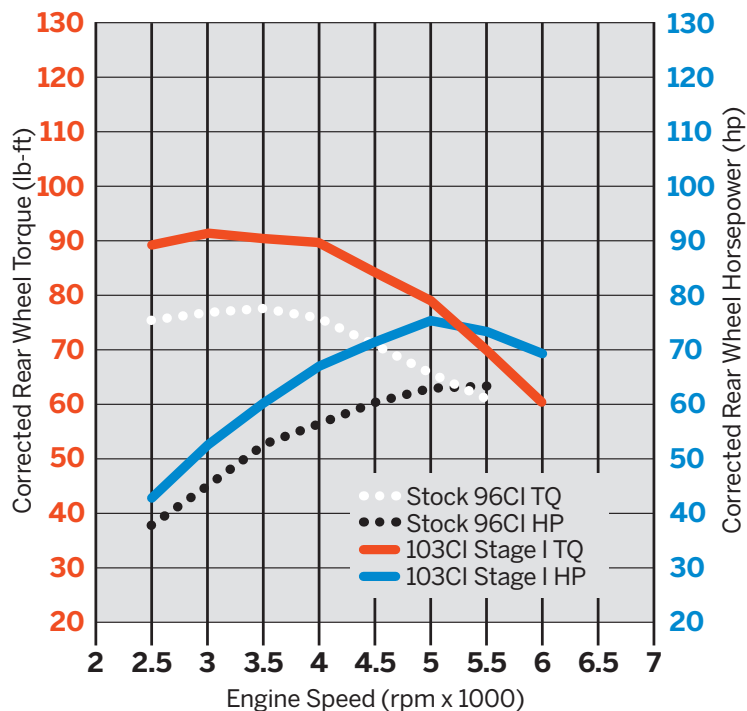

SCREAMIN' EAGLE BIG BORE STAGE I KIT FOR EFI MODELS – 103 CUBIC INCHES

Not all products are available in all countries – please consult your dealer for details.



# 498 SCREAMIN' EAGLE®

XL Stage Kits

**NEW**

## SCREAMIN' EAGLE® STAGE IV STREET PERFORMANCE KIT – SPORTSTER® MODELS

Maximize the horsepower and torque available for your street-legal Sportster® model. This complete engine package includes all the components you need to build a high-performance ride while still retaining the original factory warranty. Installation does not require removal of the powertrain from the chassis.

Kit includes:

- CNC-Ported Cylinder Heads with Performance Valve Springs
- Screamin' Eagle® XL SE-585 Cams
- Forged Hi-Compression 10.5:1 Pistons and Rings
- 58mm Throttle Body and Intake Manifold
- Top End Gasket Kit

All EFI-equipped models require dealer-installed ECM calibration download or use of the tunable Screamin' Eagle Street Tuner Kit\* (priced separately).

Fits '14-later XL1200 models. Requires separate purchase of accessory 58mm air cleaner. Model year '16 pending 50-state certification approval.

**92500041** Black Highlighted Heads.

**92500042** Black Non-Highlighted Heads.

\*Recalibration is required for proper installation, See Dealer for details. Labor cost not included.

When installed by an authorized Harley-Davidson® Dealer at the time of vehicle delivery, these kits do not impact the vehicle's limited warranty.



**Sportster 1200 Stock vs. 1200cc Stage IV Kit**  
(Shown with SE Performance Mufflers)

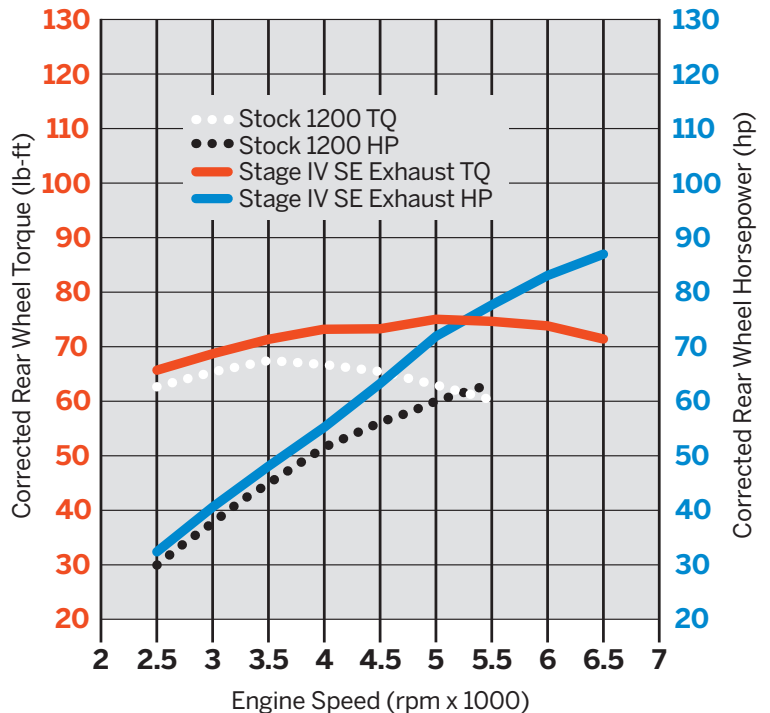

**SCREAMIN' EAGLE STAGE IV STREET PERFORMANCE KIT – SPORTSTER MODELS**

Not all products are available in all countries – please consult your dealer for details.

# SCREAMIN' EAGLE® 499

XL Stage Kits

## SCREAMIN' EAGLE® SPORTSTER® 883CC TO 1200CC STAGE I CONVERSION KIT\*

Make your Iron 883™ roar. This complete conversion kit will alter the personality of your 883-equipped Sportster® model. Designed to bring your XL883 model up to XL1200 specifications.

Kit includes:

- Sportster Stage I Air Cleaner Kit
- XL1200 Cylinder Heads
- XL1200 Cylinders
- XL1200 Pistons and Rings
- Heavy Duty Clutch Spring

No case machining is required for installation. Street legal when used with stock mufflers. All models require dealer-installed ECM calibration\* (priced separately).

**29784-07** Black Highlighted.

Fits '07-later XL883 models.

**30003-10** Black Non-Highlighted.

Fits '08-later XL883 models.

\*Recalibration is required for proper installation. See Dealer for details. Labor cost not included.

When installed by an authorized Harley-Davidson® Dealer at the time of vehicle delivery, these kits do not impact the vehicle's limited warranty.



**Sportster 883cc Stock vs. 1200cc Stage I Kit**  
(Shown with SE Performance Mufflers)

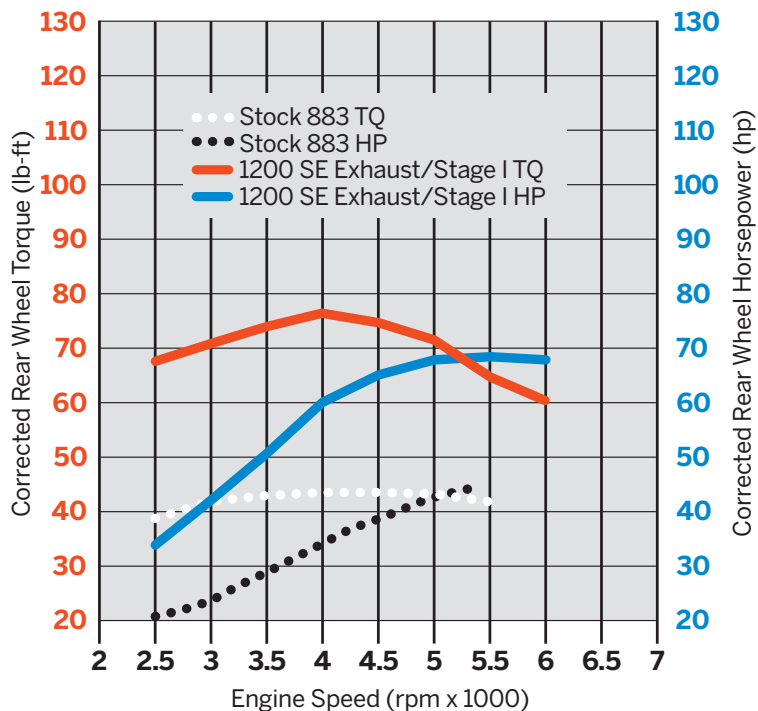

SCREAMIN' EAGLE SPORTSTER 883CC TO 1200CC STAGE I  
STREET LEGAL CONVERSION KIT

Not all products are available in all countries – please consult your dealer for details.

# CHOOSING CAMSHAFTS

Camshafts are a fundamental ingredient in the performance recipe, because they control the timing and duration of all major engine events. They are the primary means by which you can tune your engine's horsepower and torque output. Every cam has unique lift and overlap performance characteristics, which means you need to select cams based on exactly the kind of power you're looking for.

While hot cams, higher-flowing cylinder heads and a free-flowing exhaust system will move the peaks higher up the rpm band, conservative cams may feel stronger to a street rider because the maximum torque occurs at lower rpm. The experts at your Harley-Davidson® dealer have the knowledge, skill and experience to recommend the optimum cam specifications for your riding demands.



## SCREAMIN' EAGLE® TWIN CAM PERFORMANCE CAMS

Kits include front and rear cams. Splined rear cam is included for exceptional load handling capability. Gaskets and bearings not included. Dealer installation is recommended and special tools are required for proper installation. All EFI models require ECM calibration.

NOTE: Separate purchase of Cam Spacer Kit P/N 25928-06 is recommended for '06-later Dyna® and '07-later Softail® and Touring models. These kits contain five different spacers to achieve proper sprocket alignment. Individual spacers can be purchased separately.

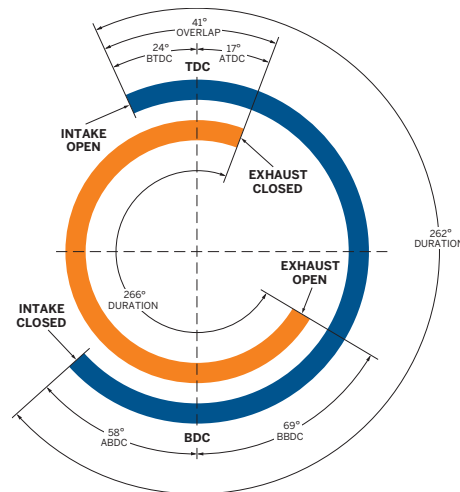

### Valve Timing Events (SE-266E shown)

- TDC = Top Dead Center (piston at very top of cylinder)
- ATDC = After Top Dead Center
- BTDC = Before Top Dead Center
- BDC = Bottom Dead Center (piston at very bottom of cylinder)
- ABDC = After Bottom Dead Center
- BBDC = Before Bottom Dead Center

### SE-204 CAM KIT

This midrange torque bolt-in cam produces peak horsepower around 5800 RPM and installation does not require any headwork or performance valve springs. Should be used in conjunction with open intake and exhaust.

### 25464-06

Street legal on '11-'13 103CI Touring and Trike models equipped with Fatshot® Mufflers P/N 80847-10.

### SE-254E CAM KIT

This cam provides great low end torque along with good midrange. A good "all-around" cam, the SE-254E is a good match for a light Touring bike – Road King®, Street Glide® or Road Glide® Custom – when the aggressive rider desires a little more top-end horsepower. In a 0-60 sprint or .25 mile drag race, the SE-254E-equipped model would pull ahead of an identical model with an SE-255 cam.

### 25503-10

Street legal on '11-'13 103CI Touring and Trike models.

### SE-255 CAM KIT

The ultimate in torque cams, this cam offers substantial increase in low end torque for engines up to 110 cubic inches with compression ratios up to 10 to 1. The low end torque increases are great for heavy bikes or for the person who routinely shifts below 4500 RPM and wants the power available to pass without downshifting. The cam still makes peak power above 5000 RPM so people with lighter bikes will enjoy the torque increases without feeling like the bike runs out of air at higher engine speeds.

### 25638-07

Street legal on '09-'13 Dyna, Softail, Touring and Trike models with 103CI and 110CI engines.

### SE-259E CAM KIT

Developed specifically for throttle body EFI systems, this cam has a modern lobe design that allows for higher valve lifts for a given duration. A high-lift version of the SE-211 camshaft, this cam works great with 103 cubic inch and larger engines with free-flowing intake and exhaust. It can be used with stock heads (updated with race springs) and high-compression pistons for even more torque than a SE-211 cam or can be coupled with any of the performance heads to realize the full power potential.

### 25482-10

Street legal on '11-later 103CI and 110CI Touring and Trike models.

### SE-585 CAM KIT

This cam is a great match for riders of heavy Touring bikes looking for big torque at the low end. Just a quick downshift to fourth gear results in an effortless pass of that slow moving tractor-trailer ahead of you. This cam provides an early hit of torque at the low end of the RPM spectrum. A unique combination of lift, cam lobe duration and an enhanced cam profile ramp provides a performance boost you can feel. The cam's QRD (Quiet Ramp Design) delivers high torque throughout the RPM range while reducing valve train noise.

### 25400117

Street legal on '14-later Touring models with the use of a 58mm Throttle Body. Also fits '14-later CVO™ Touring models with or without the use of a 58mm Throttle Body. Does not fit Trike models.

## CAM COMPARISON CHART TWIN CAM 103™ STOCK VS. 103 WITH SCREAMIN' EAGLE® AIR CLEANER, CAM AND STREET PERFORMANCE MUFFLERS

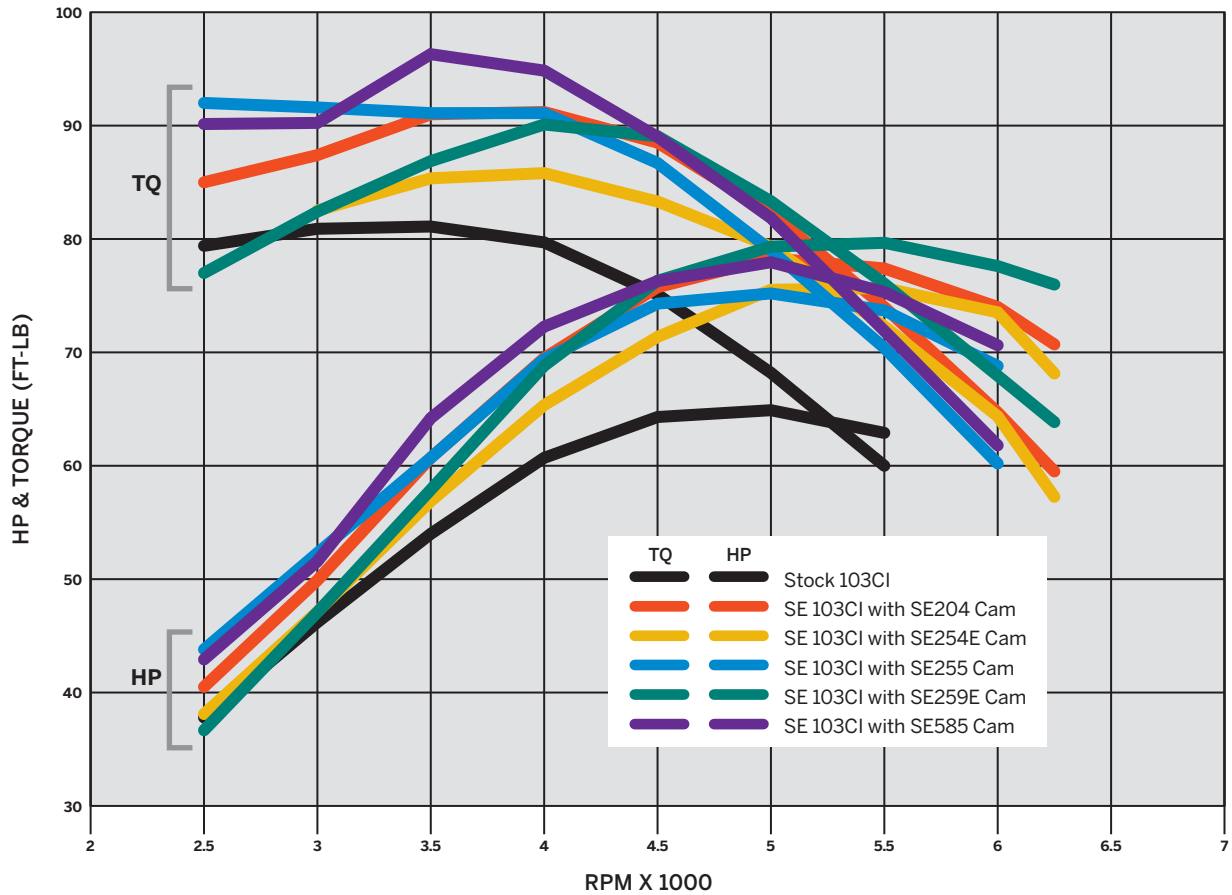

### SCREAMIN' EAGLE TWIN CAM PERFORMANCE CAM SPECS

Description	Part Number	Lift @ Valve Intake/Exhaust	Duration @.053 Intake/Exhaust	Timing @.053 Lift Open/Close	TDC Lift @ Valve Intake/Exhaust
MY14 Stock HO-103	See Service manual for specific P/N	.511" / .511"	212° / 233°	Intake: 02° BTDC / 30° ABDC Exhaust: 43° BBDC / 10° ATDC	N/A
SE-204	25464-06	.508" / .508"	236° / 240°	Intake: 22° BTDC / 34° ABDC Exhaust: 52° BBDC / 08° ATDC	0.208" / .129"
SE-254E	25503-10	.535" / .536"	224° / 234°	Intake: 01° ATDC / 43° ABDC Exhaust: 50° BBDC / 04° ATDC	0.094" / .102"
SE-255	25638-07	.556" / .556"	211° / 235°	Intake: 06° BTDC / 25° ABDC Exhaust: 48° BBDC / 07° ATDC	0.130" / .116"
SE-259E	25482-10	.579" / .579"	246° / 250°	Intake: 19° BTDC / 47° ABDC Exhaust: 58° BBDC / 12° ATDC	0.182" / .155"
SE-585	25400117	.584" / .584"	234° / 240°	Intake: 18° BTDC / 36° ABDC Exhaust: 47° BBDC / 13° ATDC	0.178" / .142"

Theoretical based on rocker arm ratio of 1.65. Valve train components, operation temperature and tolerance stack-up will affect actual lifts.

NOTE: Separate purchase of Cam Spacer Kit P/N 25928-06 is recommended for '06-later Dyna® models and '07-later Softail® and Touring models. These kits contain five different spacers to achieve proper sprocket alignment. Individual spacers can be purchased separately.

Not all products are available in all countries – please consult your dealer for details.

# 502 SCREAMIN' EAGLE®

## Shortblock Assembly

### A. CRATE ENGINE SHORTBLOCK ASSEMBLY

The perfect starting point for building the engine of your dreams. Engine shortblocks are manufactured and assembled on Harley-Davidson's main engine assembly line for exceptional quality and reliability. Shortblock cases, flywheels, bearings and rods are preassembled and ready for your custom build. Kit includes current spec Original Equipment cam plate, oil pump, cam drive components and the gaskets, seals and most of the hardware required to complete the engine and install it (not all components shown). You select your cylinders, heads, cams, covers and other top-end components. Choose one of the Screamin' Eagle® Stage kits to incorporate reliable performance and pick from our decorative engine covers to customize the look. Shortblock Assemblies are stamped with a new VIN number and include MSO (Manufacturers Statement of Origin). The MSO is for Domestic only. Kits ship directly from the factory within 3-5 days.

**16200070** Black 96CI/103CI.

Fits '07-later Dyna®, Touring and Trike models (except CVO™).

**16200071** Black 96CI/103CI.

Fits '07-later Softail® models (except FLSS, FLSTFBS and CVO).



A. CRATE ENGINE SHORTBLOCK ASSEMBLY – DYNA AND TOURING

### B. SCREAMIN' EAGLE® LEFTY BEARING

When high-performance engine modifications are made, the increased torque is transferred via the crankshaft to the drive system, putting a significantly higher load on the bearing. The Lefty Bearing is case-hardened on the inner and outer race to provide increased load capacity and enhanced durability in high-torque applications. The bearing is installed in the left side of the crankcase and supports the output shaft to the primary drive system.

**24004-03B**

Fits '03-later Twin Cam-equipped models.

### C. SCREAMIN' EAGLE TIMKEN® BEARING SLEEVE

Convert a 2003-later Twin Cam model with a factory-installed roller bearing to a Timken® tapered bearing. When used with Screamin' Eagle Timken Bearing Tool P/N 34823-08 (sold separately), the Bearing Sleeve can be installed without precision machining. Sleeve accepts press-in Timken bearing (sold separately).

**34822-08**

Fits '03-later Twin Cam-equipped models. Installation requires separate purchase of model-specific Sprocket Spacer. '03-'05 Dyna use P/N 24038-99A, '03-'06 Softail use P/N 24039-01A, '03-'06 Touring use P/N 24008-99 and '06-later Dyna and '07-later Softail, Touring and Trike models use P/N 11887. Requires separate purchase of Tapered Roller Bearing Set P/N 9028.



A. CRATE ENGINE SHORTBLOCK ASSEMBLY – SOFTAIL



B. SCREAMIN' EAGLE LEFTY BEARING



C. SCREAMIN' EAGLE TIMKEN BEARING SLEEVE

# SCREAMIN' EAGLE® 503

Engine Components

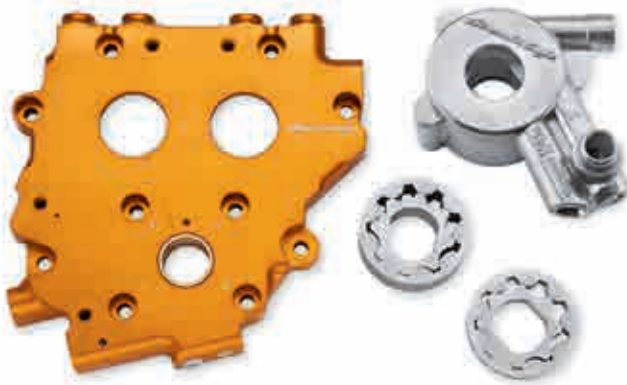

**D. SCREAMIN' EAGLE BILLET CAM SUPPORT PLATE WITH HIGH-VOLUME OIL PUMP**

## **D. SCREAMIN' EAGLE® BILLET CAM SUPPORT PLATE WITH HIGH-VOLUME OIL PUMP**

A great upgrade for any performance motor. The Billet Cam Support Plate is manufactured from billet aluminum with pressed-in bronze bushings and is pre-assembled with the crankshaft bushing and oil pressure relief valve. Aluminum is specified at 6061 billet plate, heat-treated to T6 specifications with a surface-hardened anodized finish to provide superior strength, rigidity and durability. CNC-precision machining ensures precise dimensions and constant material thickness across the plate, enabling perfect alignment of cams and chains. Cam bushings are made from 660 bronze materials to provide enhanced wear resistance and to stand up to increased loads from the high lift cams common in large displacement motors. The improved Screamin' Eagle® high-flow oil pump provides higher pressure when the oil is hot to keep pressure drops to a minimum and increases the oil supply by 16% and the scavenging by 29% over the '06-later Original Equipment oil pump.

### **25282-11**

Fits '06-later Dyna® and '07-later Softail®, Touring and Trike models. Installation requires separate purchase of Cam Service Kit P/N 17045-99D and Drive Gear Retention Kit P/N 25566-06.

## **E. SCREAMIN' EAGLE HYDRAULIC CAM CHAIN TENSIONER AND HIGH-FLOW OIL PUMP UPGRADE KIT**

This kit updates the cam chain tensioner of your Twin Cam 88® engine to the latest design, as featured on the Twin Cam 96™ engine. The billet cam support plate has been designed to allow the installation of the Twin Cam 96 hydraulic cam chain tensioner to Twin Cam 88-equipped models. These Hydraulic Cam Chain Tensioners will significantly outlast the spring loaded tensioners and are an ideal addition to an engine modified for improved performance. In addition, '02-'06 models utilize a Twin Cam 96 single row front roller chain and sprocket (included in kit). '99-'01 models use Original Equipment front silent chain and sprocket to retain the cam position sensor function. The kit includes an improved Screamin' Eagle High-Flow Oil Pump that provides increased oil pressure at high-operating temperatures. This kit increases the oil supply by 23% and scavenging by 50% when compared to the '99-'05 Original Equipment oil pump and reduces operating temperature of bearings to improve bearing life.

### **25284-11**

Fits '99-'05 Dyna, '00-'06 Softail and '99-'06 Touring models. Installation requires separate purchase of Spacer Kit P/N 25285-08, Cam Service Kit P/N 17045-99D and Drive Gear Retention Kit P/N 25566-06.



**E. SCREAMIN' EAGLE HYDRAULIC CAM CHAIN TENSIONER AND HIGH-FLOW OIL PUMP UPGRADE KIT**

## **F. SCREAMIN' EAGLE HIGH-PERFORMANCE INNER CAM BEARINGS**

High-performance Inner Cam Bearings are a smart upgrade when installing high-lift cams in a race bike. These bearings provide increased load capacity and extend the engine life in extreme racing conditions. Kit includes two bearings required to complete one Twin Cam engine.

### **24017-10**

Fits '99-'05 Dyna, '00-'06 Softail and '99-'06 Touring models.

### **24018-10**

Fits '06-later Dyna and '07-later Softail and Touring models.

**Also available:** (not shown):

### **SCREAMIN' EAGLE EVOLUTION® 1340 INNER CAM BEARING**

Kit includes single cam bearing.

### **9058A**

Fits Evolution® 1340 models.



**New Pump Rotor**

**Original Pump Rotor**

**HIGH VOLUME OIL PUMP COMPARISON**



**F. SCREAMIN' EAGLE HIGH-PERFORMANCE INNER CAM BEARINGS**

Not all products are available in all countries – please consult your dealer for details.

# 504 SCREAMIN' EAGLE®

## Engine Components

### A. SCREAMIN' EAGLE® PREMIUM TAPERED QUICK-INSTALL ADJUSTABLE PUSHRODS

These premium pushrods are tapered for enhanced clearance at the cylinder head, allowing the use of higher lift cams. The one-piece chrome moly tube adds rigidity and durability and the threaded adjustment feature provides easy cam installation without removing the cylinder heads or rocker boxes. To simplify adjustment, the tube features six flats, with one flat marked with a large dot for tracking the adjustment. The threaded rod features 4 flats to reduce wrench swing. Each pushrod features the Screamin' Eagle logo and is marked for "Intake" or "Exhaust." Kit includes 4 pushrods and required pushrod tubes.

Fits '99-later Twin Cam-equipped models.

**17900032** With Gloss Black Covers.

**18404-08** With Chrome Covers.

### B. SCREAMIN' EAGLE QUICK-INSTALL PUSHROD KIT FOR TWIN CAM-EQUIPPED MODELS

These pushrods have been designed to allow for easier installation, adjustment and improved durability. This unique Screamin' Eagle design allows for installation of camshafts in the Twin Cam without the removal of the heads or rocker boxes. This design is also a great performer, constructed of stiff chrome moly tubing and thread-rolled adjusters. Kit includes required pushrod tubes and clips for adjustment of pushrods.

**17997-99A**

Fits '99-later Twin Cam-equipped models.

### C. PUSHROD COVER KIT – GLOSS BLACK

Complete the Dark Custom look. These covers replace existing chrome covers to give your bike a blacked-out appearance down to the smallest detail. Pushrod covers are finished in gloss black and the kit includes the four bottom cover tubes and the four upper clips. Installation retains the Original Equipment chrome short center tube to create a high-contrast accent. Cover Kit can be installed on engines already equipped with Adjustable Pushrods or can be installed by removing rocker box covers, rocker arms and non-adjustable pushrods. Consult your dealer or service manual for installation.

**17900033** Covers Only.

Fits '99-later Twin Cam-equipped models. Requires prior installation of Adjustable Pushrods or removal of rocker box covers, rocker arms and fixed-length pushrods.

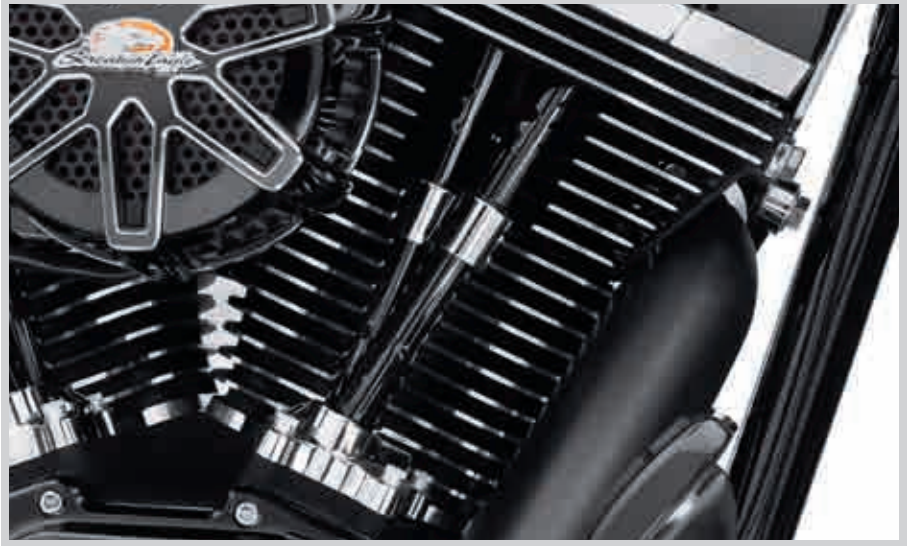

A. SCREAMIN' EAGLE PREMIUM TAPERED QUICK-INSTALL ADJUSTABLE PUSHRODS – GLOSS BLACK COVERS



A. SCREAMIN' EAGLE PREMIUM TAPERED QUICK-INSTALL ADJUSTABLE PUSHRODS – GLOSS BLACK COVERS



A. SCREAMIN' EAGLE PREMIUM TAPERED QUICK-INSTALL ADJUSTABLE PUSHRODS – CHROME COVERS



B. SCREAMIN' EAGLE QUICK-INSTALL PUSHROD KIT FOR TWIN CAM-EQUIPPED MODELS



C. PUSHROD COVER KIT – GLOSS BLACK

# SCREAMIN' EAGLE® 505

Engine Components

High Capacity



Stock

**D. SCREAMIN' EAGLE HIGH-CAPACITY TAPPETS**



**E. SCREAMIN' EAGLE TAPPETS**

## **D. SCREAMIN' EAGLE® HIGH-CAPACITY TAPPETS**

Screamin' Eagle® Tappets feature large high capacity needles in the roller bearing assembly to improve reliability when operating with high lift cams, high pressure valve springs and in high RPM applications. The 25% larger needle bearings increase the dynamic load rating by approximately 20% when compared to the Original Equipment Twin Cam tappets. The unique design delivers superior tappet life in performance applications. Set of 4.

**18572-13**

Fits '99-later Twin Cam-equipped models and '00-later XL and XR models.

## **E. SCREAMIN' EAGLE TAPPETS**

These Screamin' Eagle Tappets incorporate a unique axle, roller and bearing design that increases durability and stability of the tappets. Works well in high horsepower/high RPM applications. Set of 4.

**18568-98**

Fits '84-'99 Evolution® 1340-equipped models and '86-'90 XL models.

## **F. SCREAMIN' EAGLE PERFORMANCE VALVE SPRING KIT\***

This performance Beehive-shaped Valve Spring Kit will permit the Sportster® engine to rev to 7000 RPM. The unique ovate wire yields increased performance from a compact spring design. The installed spring pressure is increased to 208 lbs and allows a maximum lift of .590". Complete kit includes springs, upper collars and keepers and lower collars with integral valve seals.

**18013-03A**

Fits '04-later XL, XR and '05-later Twin Cam-equipped models. Does not fit FLSS, FLSTFBS or Screamin' Eagle Performance Heads with .3125" diameter valves.

## **G. SCREAMIN' EAGLE ROLLER ROCKER ARMS**

Unique roller-tip design increases strength and reduces valve stem side-loading and tip friction. Built to handle cams with up to .700" lift in high RPM application. Set of 4.

**17378-98**

Fits '84-'99 Evolution 1340-equipped models, '86-later XL and XR models and '99-later Twin Cam-equipped models. (Modification is required on Twin Cam rocker covers.)

## **H. SCREAMIN' EAGLE TWIN CAM FORGED ROCKER SUPPORTS**

Increased strength rocker supports will handle the increased loads from higher lift cams and higher RPM applications. This product keeps valve train geometry solid. Works with stock or roller rocker arms. Includes required hardware for installation.

**17675-01B**

Fits '99-later Twin Cam-equipped models.

## **I. SCREAMIN' EAGLE BIG BORE HIGH PERFORMANCE HEAD GASKET KIT**

This multi-layered head gasket provides improved sealing for 3.875" Big Bore high performance engines. For engines with compression ratios above 10.0:1, Screamin' Eagle High Tensile Cylinder Studs P/N 16505-01 are required. Sold in pairs.

**16101-01**

Fits '99-later Big Bore (3.875" bore) Twin Cam-equipped models. Does not fit Twin-Cooled™ equipped models.



**F. SCREAMIN' EAGLE PERFORMANCE VALVE SPRING KIT**



**G. SCREAMIN' EAGLE ROLLER ROCKER ARMS**



**H. SCREAMIN' EAGLE TWIN CAM FORGED ROCKER SUPPORTS**



**I. SCREAMIN' EAGLE BIG BORE HIGH PERFORMANCE HEAD GASKET KIT**

**\*CAUTION:** Proper valve spring to rocker cover clearance must always be verified during installation of Screamin' Eagle Valve Spring Kits. Failure to have adequate clearance may result in engine damage.

Not all products are available in all countries – please consult your dealer for details.



# 506 SCREAMIN' EAGLE®

Ignition

## A. SCREAMIN' EAGLE® ST PERFORMANCE SPARK PLUG

Screamin' Eagle® ST Spark Plugs feature double platinum coating for superior erosion resistance and extended life. The "V" trimmed ground electrode reduces shrouding of the flame front to promote flame propagation and the fine wire center electrode enhances start ups and ignitability. Screamin' Eagle ST Plugs feature Ribbed Core Technology (RCT) that provides resistance to fouling and are designed with Original Equipment-style noise suppression to prevent electrical interference with radios and CB communication equipment. Works great in racing applications where rich air/fuel conditions are required. Unique style with Screamin' Eagle logo. Sold in pairs.

### High Compression Applications

These plugs are designed for high performance applications involving modifications in high-flow air cleaners, camshafts, exhaust, performance heads, ignition components, higher compression ratios above Original Equipment configurations or engines specific for racing applications.

### 32186-10

Fits '99-later Twin Cam-equipped models, '86-later XL and XR models and Evolution® 1340 models equipped with Screamin' Eagle Performance Cylinder Heads.

### 32188-10

Fits '84-'99 Evolution 1340-equipped models, '75-'81 Shovelhead 74 and 80CI and '83-'84 XR1000 models.

### Stock Compression Applications

Designed for modified engines including performance carburetors, high-flow air cleaners, camshafts, exhaust systems and ignition systems in conjunction with stock compression ratios.

### 32189-10

Fits '84-'99 Evolution 1340-equipped models, '75-'81 Shovelhead 74 and 80CI models.

### 32192-10

Fits '99-later Twin Cam-equipped models and '86-later Evolution Sportster® 883, 1100 and 1200 models.

## B. SCREAMIN' EAGLE TERMINATED PLUG WIRE KITS – EVOLUTION ENGINES

These custom 8mm terminated plug wire sets are larger in diameter than stock wires and feature silicone plug boots and suppression core so that your electronic ignition is not affected. Use with your stock production coil or the perfect addition when upgrading to one of our Performance Coils.

### 32094-98 Black.

Fits '97-'98 FLHR, FLHT, FLHTC and FLHTCU models.

### 32090-98 Black.

Fits '82-'99 FXR models.

### 32091-98 Black.

Fits '85-'96 Evolution 1340 FLHR, FLHT and FLT and '82-'93 FLHS models.



A. SCREAMIN' EAGLE ST PERFORMANCE SPARK PLUG



B. SCREAMIN' EAGLE TERMINATED PLUG WIRE KIT – EVOLUTION ENGINES

# SCREAMIN' EAGLE® 507

Ignition



C. SCREAMIN' EAGLE 10MM PHAT SPARK PLUG WIRES



C. SCREAMIN' EAGLE 10MM PHAT SPARK PLUG WIRES



C. SCREAMIN' EAGLE 10MM PHAT SPARK PLUG WIRES – CUT TO LENGTH

## C. SCREAMIN' EAGLE® 10MM PHAT SPARK PLUG WIRES

Fat 10mm plug wires add dimension and style to your ride. Screamin' Eagle® boot design and suppression core wires ensure solid connection and maximum voltage transfer between coil and plugs. "Screamin' Eagle" logo printed along wire to add style.

Fits '09-later Touring and Trike models.

**32303-08** Black.

**32318-08** Red.

**32325-08** Orange.

Fits '99-'08 Touring models.

**31932-99B** Black.

**31939-99B** Red.

**31946-99B** Orange.

Fits '99-later Dyna® models.

**31930-99B** Black.

**31937-99B** Red.

**31944-99B** Orange.

Fits '00-later Softail® models (except FXCW, FXCWC, FXS and FXSB models).

**31907-08** Black.

**32359-00B** Red.

**32360-00B** Orange.

Fits '08-later FXCW, FXCWC, FXS and FXSB models.

**31965-08** Black.

**31967-08** Red.

Fits '91-'98 Dyna, '85-'99 Softail and '80-'84 Touring models.

**32093-98A** Black.

**31964-89B** Orange.

Fits '07-later XL models.

**31901-08** Black.

**31902-08** Orange.

Fits '04-'06 XL models.

**31958-04A** Black.

**31956-04A** Orange.

Fits '86-'03 XL models (except XL1200S).

**32092-98A** Black.

**31963-89A** Orange.

Fits '15-later XG models.

**31600048** Black.

**31600054** Red.

**31600051** Orange.

Multi-Fit – Cut to length. Does not fit XG models.

**32095-98A** Black.

**31987-85B** Yellow.

Not all products are available in all countries – please consult your dealer for details.

# 508 SCREAMIN' EAGLE®

## Engine Components

### A. SCREAMIN' EAGLE® HIGH CAPACITY OIL PAN

Keep your engine running cooler with by increasing your Touring bike's oil capacity. A great addition to a high-performance motor or for the rider that tours in extreme temperature conditions, the Screamin' Eagle® cast-aluminum oil pan is designed to increase the oil capacity by 1.5 quarts over the Original Equipment pan. Increased capacity means the oil cycles through the engine less frequently and the oil can remain in the pan for a longer period of time. The cast-in internal baffles manage the flow to the oil pickup and keep the hot oil exposed to the heat-conducting ribbed aluminum sump. Kit includes cast aluminum oil pan and pan gasket.

#### 24400099

Fits '09-later Touring models. Does not fit with Oil Temperature Gauge – Fairing Mount P/Ns 70900284, 70900283, 70900176, 70900193. Does not fit Trike models.



### B. SCREAMIN' EAGLE AUTOMATIC COMPRESSION RELEASE

Automatic Compression Release (ACR) valves reduce the strain of starting your high performance motor by reducing cylinder compression – automatically! The engine is easier to turn over, resulting in less wear on your starter and battery. After start, the ACR valves close to restore full compression. ACR gives you peace of mind and protects your investment. ACR can be installed on stock or Screamin' Eagle Performance cylinder heads for all '07-later Twin Cam-equipped models. Installation requires machining to be performed by a competent machinist using the Screamin' Eagle Automatic Compression Release Fixture Kit P/N 94648-08 (sold separately). Installation requires separate purchase of model-specific ACR Wiring Harness. Sold individually.

#### 28861-07A

Fits '07-later Twin Cam-equipped models. Can be used with Original Equipment or Screamin' Eagle Cylinder Heads. Does not fit with Twin-Cooled™ engines.



### C. SCREAMIN' EAGLE AUTOMATIC COMPRESSION RELEASE WIRING HARNESS

#### 70623-06

Fits '07-'11 Dyna®, '07-'10 Softail® and '07 Touring models equipped with Automatic Compression Release Cylinder Heads.

#### 70623-08

Fits '08-'11 Touring models equipped with Automatic Compression Release Cylinder Heads.

#### 70623-11

Fits '11 Softail models equipped with Automatic Compression Release Heads.

A. SCREAMIN' EAGLE HIGH CAPACITY OIL PAN



B. AUTOMATIC COMPRESSION RELEASE



C. AUTOMATIC COMPRESSION RELEASE WIRING HARNESS

# SCREAMIN' EAGLE® 509

Clutch & Drivetrain

## D. SCREAMIN' EAGLE® BIG TWIN COMPENSATOR

This premium compensator has been engineered with heavier springs and increased travel to support the high torque output associated with high compression race and large displacement engines. Designed to outperform the Original Equipment compensator, this unit helps protect the engine and driveline components during harsh drag race launches. Compensator features improved oil passages, oil deflectors and a needle bearing thrust washer that improves the overall operation of these components.

### 42200064A

Fits '12-'13 Dyna®, '12-'13 Softail® (except FXCW, FXCWC, FXSB, FXSBSE and '09 FXSTSSE) and '11-'13 Touring and Trike models. Original Equipment on '14-later Dyna, Softail and Touring models. Requires separate purchase of Installation Adhesive Kit P/N 11100088.

### 40100061

Fits '06-'11 Dyna, '07-'11 Softail (except FXCW and FXCWC), '07-'10 Touring, and '07-'09 CVO™ 0(except '09 FXSTSSE) models. Does not fit Trike. Requires separate purchase of Installation Adhesive Kit P/N 11100088. Kit includes Rotor Assembly P/N 30041-08. Installation on '06 Dyna models require separate purchase of '07-style stator.

### 42200095A

Fits '08-'12 FXCWC and '09 FXSTSSE models and '13-later FXSB models. If P/N 40274-08A has been installed previously, the rotor shell, P/N 30041-08A is not required.

## E. SCREAMIN' EAGLE MANUAL PRIMARY CHAIN TENSION ADJUSTER

The Screamin' Eagle® Manual Primary Chain Tension Adjuster is a real benefit in those aggressive racing situations where frequent drag racing starts and high rpm speed shifting are part of the riding experience. Ideal for bikes equipped with big displacement high performance (100hp+) engines that are regularly used for track-day drag racing; this Screamin' Eagle Tension Adjuster permits manual selection of primary chain tension. A direct replacement for the Original Equipment automatic version, this anodized billet aluminum adjuster allows you to fine-tune the settings and lock the position when the freeplay is properly set. The manual adjustment locks the chain tension in place to prevent the chain from adjusting during severe shifting. Kit includes required mounting hardware.

### 36500020

Fits '06-later Dyna and '07-later Softail, Touring and Trike models. Requires separate purchase of model-specific primary gaskets and seals.

## F. AUTOMATIC PRIMARY CHAIN TENSION ADJUSTER

Original Equipment on '06-later Dyna and '07-later Softail and Touring models, this Automatic Primary Chain Adjuster eliminates the need to manually adjust the primary chain tension at traditional service intervals.

### 40063-05B

Fits '85-'06 Evolution® 1340 (except '85-'88 Softail) and Twin Cam powertrain. Requires separate purchase of model-specific primary gasket and seals.



D. SCREAMIN' EAGLE BIG TWIN COMPENSATOR



E. SCREAMIN' EAGLE MANUAL PRIMARY CHAIN TENSION ADJUSTER



F. AUTOMATIC PRIMARY CHAIN TENSION ADJUSTER

# 510 SCREAMIN' EAGLE®

Clutch & Drivetrain

## A. SCREAMIN' EAGLE® TWIN CAM PERFORMANCE ASSIST AND SLIP (A&S) CLUTCH KIT

Developed for the high-thrust 110CI engine featured as Original Equipment on '14-later Screamin' Eagle® CVO™ models, this A&S clutch provides significantly increased torque-handling capacity (115lb/ft). Clutch is designed to improve engagement grip and provides minor slippage during downshifting to reduce shock to the power train. Reduces hand lever pull effort by over 1 pound. Complete kit features improved clutch plates for enhanced wear resistance and is the perfect addition when installing a high-output Screamin' Eagle Stage Kit.

### 37000026

Fits '14-later Touring and Trike models with hydraulic clutch actuator.

## B. SCREAMIN' EAGLE VARIABLE PRESSURE CLUTCH

Get more performance from the Original Equipment clutch. The Screamin' Eagle Variable Pressure Clutch is designed to help put the added power from a Screamin' Eagle Stage Kit to the pavement. This bolt-on kit harnesses the centrifugal force of spinning weights to increase the clutch capacity as engine speed increases. The mechanism applies increasing pressure to the stock clutch pressure plate as RPM rises. The result: High torque-handling capabilities without increasing clutch lever effort at idle. The Variable Pressure Clutch also provides smoother clutch disengagement at lower speed. Kit fits behind most stock derby covers with no modifications. See installation manual for additional accessory derby cover fitment information.

To match the performance demands of your engine, team the Variable Pressure Clutch with your choice of clutch diaphragm springs. We recommend the higher capacity Screamin' Eagle Diaphragm Spring P/N 37951-98 for major performance upgrades.

	Lever Effort	Torque Capacity
Original Equipment Spring	Same as stock	120 ft-lbs
SE Spring P/N 37951-98	35% greater than stock	153 ft-lbs

### 37000121

Fits '99-later Evolution® 1340 and Twin Cam-equipped models. Will not fit '16-later Touring and Trike models, '15-later FLHTCUL or FLHTKL models or '07-later Touring or Trike models equipped with Narrow-Profile Outer Primary Cover P/N 25700385 or 25700438. Will not fit '13-later CVO models with hydraulic actuated clutch, '16-later FLSS and FLSTFBS, or '14-later Touring and Trike models equipped with Screamin' Eagle A&S Clutch Kit P/N 37000026. Derby Covers P/N 25001-03, 25441-04A, 25770-99, 25331-10, 25339-10, 25700250 and 25700062 require Spacer Kit P/N 37000123. Does not fit Derby Covers P/N 25347-02 or 25345-01.



A. SCREAMIN' EAGLE TWIN CAM PERFORMANCE ASSIST AND SLIP CLUTCH KIT



B. SCREAMIN' EAGLE VARIABLE PRESSURE CLUTCH

# SCREAMIN' EAGLE® 511

Clutch & Drivetrain



**C. SCREAMIN' EAGLE TWIN CAM PERFORMANCE RACE CLUTCH HUB KIT**



**D. SCREAMIN' EAGLE RACE CLUTCH KIT**



**E. SCREAMIN' EAGLE PERFORMANCE CLUTCH FRICTION DISC KIT**



**F. HEAVY DUTY CLUTCH SPRING FOR STOCK CLUTCH**



**G. SCREAMIN' EAGLE PERFORMANCE CLUTCH KIT**



**H. SCREAMIN' EAGLE PERFORMANCE SLIPPER CLUTCH FOR VRSC MODELS**

## **C. SCREAMIN' EAGLE® TWIN CAM PERFORMANCE RACE CLUTCH HUB KIT**

Innovative new clutch hub kit offers improved clutch performance and is perfect for large displacement applications. Will support engines producing up to 160 ft-lbs of torque. Kit includes the hub, pressure plate and clutch springs and can be used with stock friction discs and spacers or Screamin' Eagle® Friction Disc Kit P/N 37980-10. (Does not include clutch friction plates.)

### **37976-08A**

Fits '07-later Twin Cam-equipped models. Will not fit '13-later CVO™ Touring models with hydraulic actuated clutch, '15-later FLHTCUL, FLHTKL, '16-later FLSS, FLSTFBS, or '14-later Touring models equipped with Screamin' Eagle A&S Clutch Kit P/N 37000026.

## **D. SCREAMIN' EAGLE RACE CLUTCH KIT**

This clutch has an innovative design that features new long life friction plates and 6 individual coil springs to adjust your clutch to your specific needs. Designed to handle up to 160 ft-lbs of torque at the crank.

### **37970-03A**

Fits '90-'99 Evolution® 1340-equipped models and '99-'06 Softail® and Touring and '99-'05 Dyna® models.

NOTE: '90-'97 Evolution 1340-equipped models require Clutch Shell P/N 37707-98A and Rod Adjuster Screw P/N 37090-98A. '90-'93 Evolution 1340-equipped models also require starter P/N 31553-94B.

## **E. SCREAMIN' EAGLE PERFORMANCE CLUTCH FRICTION DISC KIT**

Newly-developed friction material delivers longer life than Original Equipment friction discs. Kit includes new precision-machined flat steel plates. This Friction Disc Kit is a perfect match for the Screamin' Eagle Twin Cam Performance Race Clutch Hub Kit P/N 37976-08.

### **37980-10**

Fits '99-later Twin Cam-equipped models and '98-'99 Evolution 1340-equipped models. Will not fit '13-later CVO Touring models with hydraulic actuated clutch or, '15-later FLHTCUL and FLHTKL, '16-later FLSS, FLSTFBS, or '14-later Touring and Trike models equipped with Screamin' Eagle A&S Clutch Kit P/N 37000026.

## **F. HEAVY DUTY CLUTCH SPRING FOR STOCK CLUTCH**

### **37951-98**

Fits '99-later Twin Cam-equipped models and '98-'99 Evolution 1340-equipped models. Will not fit '13-later CVO Touring models with hydraulic actuated clutch or, '15-later FLHTCUL and FLHTKL, '16-later FLSS, FLSTFBS, or '14-later Touring and Trike models equipped with Screamin' Eagle A&S Clutch Kit P/N 37000026.

## **G. SCREAMIN' EAGLE PERFORMANCE CLUTCH KIT**

Performance Clutch Kit converts the 8-plate clutch to a 9-plate design. The surface area is increased by 13% and the spring rate is increased by 10% for a combination that can handle over 115 ft-lbs of torque at the crank, a 23% increase over the stock-rated capacity. Kit includes Kevlar® fiber-based friction discs and performance clutch spring.

### **38002-04**

Fits '91-later XL and '94-'97 Evolution 1340-equipped models.

## **H. SCREAMIN' EAGLE PERFORMANCE SLIPPER CLUTCH FOR VRSC™ MODELS**

This clutch offers reduced lever effort and improved performance. The unique "slip and assist" ramp system opens the two halves of the clutch hub slightly during high loads to the drivetrain, allowing a moderate slip that reduces shock to the drivetrain during rapid downshifting. The resulting reduction in wheel hop allows maximum contact between the tire and the road in wet or slippery conditions. Clutch lever effort is also reduced by 20% in 1130cc and 30% on 1250cc applications.

### **37938-08KA**

Fits '02-'07 VRSC™ models.

## SCREAMIN' EAGLE® CRATE ENGINE & LONGBLOCK PROGRAM

When the heart of your Harley® motorcycle gets a little tired – we can help wake it up. We offer complete crate motors and short block assemblies for a wide variety of models or we can supply a factory-fresh Twin-Cam LongBlock complete with your original VIN to get you back on the road.

*Not all products are available in all countries –  
please consult your dealer for details.*

**SCREAMIN' EAGLE  
TWIN-CAM 103™ CRATE ENGINE**

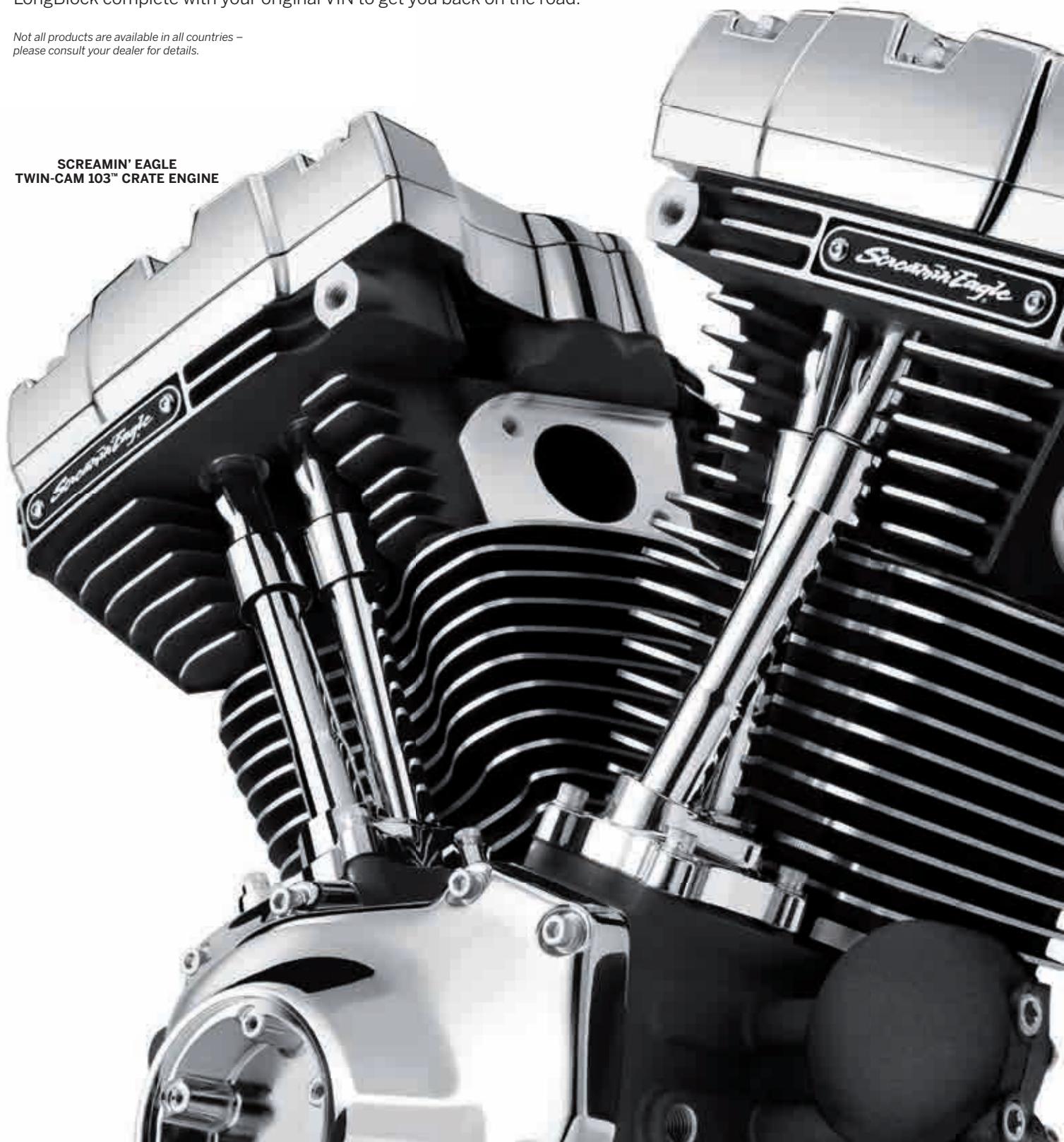

# SCREAMIN' EAGLE® 513

Twin Cam Engines



A. TWIN CAM ENGINE – SOFTAIL, BLACK AND CHROME 110B

## A. TWIN CAM ENGINE

The balanced Twin Cam Engine has brought a whole new ride to the Softail® family. And now, you can get the most technologically advanced, air-cooled, V-Twin engines to refresh your ride. Available in 103CI and 110CI configurations, these engines are street-legal when installed in the models specified. Manufactured to the latest specifications, these engines are available in a variety of finishes to suit your customizing direction. See your Dealer for details.

NOTE: CVO™ 103B™ engines now feature factory installed Screamin' Eagle® Hydraulic Cam Chain Tensioner Plate and Oil Pump upgrade kit. This latest cam chain tensioner design will significantly outlast the Original Equipment-style spring tensioners and the upgraded oil pump increases oil flow by 8% and oil scavenging by 22%.

### 1800cc Screamin' Eagle® Twin Cam 110B™

Fits '07-later CVO Softail® models. Does not include intake system, timer cover, stator, rotor or compensating sprocket assembly.

**19293-16** Black and Chrome.

### 1690cc Screamin' Eagle Twin Cam 103B™

Fits '06 FLSTFSE models. Includes Screamin' Eagle Hydraulic Cam Chain Tensioner and Oil Pump upgrade. Does not include intake system, timer cover, stator, rotor or compensating sprocket assembly.

**19293-06D** Black and Chrome.

**19296-06D** Silver and Chrome.

### 1690cc Twin Cam 103B

Fits '12-later Softail models factory equipped with a Twin Cam 103B engine. Does not include intake system, timer cover, stator, rotor or compensating sprocket assembly.

**19811-16** Black and Chrome.

### 1800cc Screamin' Eagle Twin Cam 110A™

Fits '13-'14 FLHRSE, '08-'13 FLHTCUSE, FLTRXSE and FLTRUSE and '10-later FLHXSE models. Requires installation of oil cooler and cover kit. Does not include intake system, timer cover, stator, rotor or compensating sprocket assembly.

**19176-16** Black and Chrome.

### 1690cc Twin Cam 103A™

Fits '10-'13 FLHTK, '11-'13 Touring and '10-'13 FLHTCUTG models factory equipped with Twin Cam 103A™ engine. Does not include intake system, timer cover, stator, rotor or compensating sprocket. Does not fit Twin Cooled equipped models.

**19678-13B** Black and Chrome.

Fits '14-later Touring (except Twin-Cooled™) and '15-later FLRT models. Does not include intake system, timer cover, stator, rotor or compensating sprocket assembly.

**19678-16** Black and Chrome.

### 1690cc Screamin' Eagle Twin Cam 103A

Fits '06 FLHTCUSE models. Includes Screamin' Eagle Hydraulic Cam Chain Tensioner and Oil Pump upgrade. Requires installation of Oil Cooler P/N 62994-04 and Cover Kit P/N 62995-04. Does not include intake system, timer cover, stator, rotor or compensating sprocket assembly.

**19264-06D** Silver and Chrome.

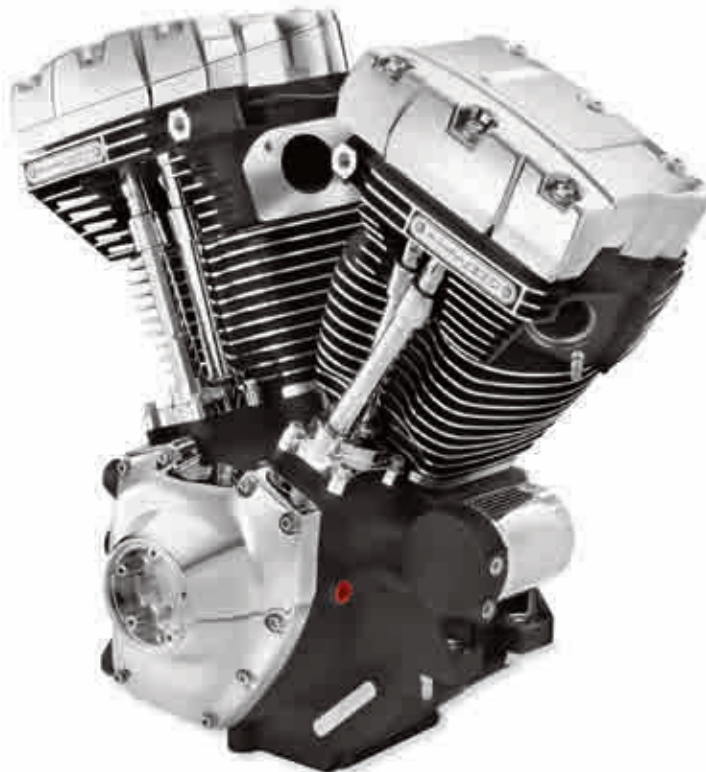

A. TWIN CAM ENGINE – DYNA AND TOURING, BLACK AND CHROME 110A

Not all products are available in all countries – please consult your dealer for details.



# 514 SCREAMIN' EAGLE®

Engines & Transmissions

## A. REVOLUTION X™ XG750 ENGINE

With the launch of the new Harley-Davidson® Street™ motorcycles, the world has been introduced to a new powertrain from Harley-Davidson. This engine is now available from your HD dealer. Available in black, the engine comes complete with clutch system, stator/rotor charging system and transmission. Does not include throttle body or ECM.

**20022-16** Black and Highlighted.  
Fits '15-later XG750 models.

## B. REVOLUTION® VRSC™ ENGINE

With the launch of the V-Rod® motorcycle in 2002, the world was introduced to a revolutionary new powertrain and now the Revolution engine is available from your Harley-Davidson® dealer. Available in gloss black 1250cc configuration as featured as Original Equipment on the 2015 V-Rod models.

**19973-16K** Gloss Black.  
Fits '12-later VRSC™ models. Does not include charging system or induction system.

## C. SIX-SPEED CRUISE DRIVE® TRANSMISSION – SOFTAIL

**33006-14** Black and Chrome.  
Fits '10-later Softail® models (except CVO™, FLSS, FLSTFBS, FXCW, FXCWC and FXSB). Includes clutch cable for FLSTC models.

## D. SIX-SPEED CRUISE DRIVE TRANSMISSION – TOURING

**32228-16** Black and Chrome.  
Fits '10-later Touring models (except CVO and models with hydraulic activated clutch). Includes clutch cable.



A. REVOLUTION X ENGINE - BLACK AND HIGHLIGHTED



B. REVOLUTION VRSC ENGINE – GLOSS BLACK



C. SIX-SPEED CRUISE DRIVE TRANSMISSION – SOFTAIL, BLACK AND CHROME



D. SIX-SPEED CRUISE DRIVE TRANSMISSION – TOURING, BLACK AND CHROME

NOTE: Replacement engines must be re-fitted with emission control devices and systems, appropriate for the vehicle model and model year in order to ensure emissions compliance. Failure to do so constitutes tampering under US EPA guidelines and can lead to substantial fines and penalties.

Legal for use on public roads only when installed in the specified models. Not legal for use on public roads when installed in models other than the ones specified and not eligible for the P&A 24-month warranty when installed in models other than the ones specified. Please see the Parts and Accessories warranty statement and your dealer for more information.

*Not all products are available in all countries – please consult your dealer for details.*

# SCREAMIN' EAGLE® 515

Transmission

## E. SCREAMIN' EAGLE® 6-SPEED TRANSMISSION AND GEAR SET

Designed from the ground up, the Screamin' Eagle® transmission incorporates many of the best Original Equipment features, like late-style shifting mechanism and a newly designed "shift ring" system to make this the smoothest shifting Harley-Davidson® transmission available. The "shift ring" system is similar to the system used in the VRSC™ transmission and it slides on the shafts to mate into the gears. This eliminates sliding heavy gears to accomplish the shift and results in smooth, precise and light effort shifting. Sixth gear is a true overdrive, at a .89:1 ratio and the first five gears mimic today's proven 5-speed ratios. The overdrive feature allows you to run a lower engine RPM in sixth gear, at any given road speed. Lower RPM can result in lower vibration, longer engine life and smoother cruising. The Screamin' Eagle 6-Speed Transmission is available as a complete transmission or as a replacement gear set and can be matched with hydraulic or cable-operated clutch controls.

Screamin' Eagle 6-Speed Transmissions feature forged chrome "trap door," forged shifter forks and forged and precisely ground gears. No speedometer or exhaust mount modifications are required. Complete transmissions are ready to install into the chassis and the 6-Speed Gear Set Kits are designed to replace the stock gear set without removing the transmission. Gear Set Kits require slight modification (template included) to the Original Equipment transmission case and include all necessary installation hardware.

### COMPLETE TRANSMISSION

**33040-03A** Black and Chrome.

Fits '01-'05 Dyna® models. Requires separate purchase of appropriate Side Cover Release Kit.

**33045-03A** Black and Chrome.

Fits '00-'06 Softail® models. Requires separate purchase of appropriate Side Cover Release Kit.

**33137-04** Black and Chrome.

Fits '02-'06 Touring models. Requires separate purchase of appropriate Side Cover Release Kit.

### GEAR SET

**33100-03A**

Fits '91-'94 and '96-'00 Dyna and '90-'99 Softail models. Requires separate purchase of appropriate Side Cover Release Kit.

**33101-03A**

Fits '90-'00 Touring models. Requires separate purchase of appropriate Side Cover Release Kit.

**33102-03A**

Fits '00-'06 Softail and '01-'06 Touring models. Requires separate purchase of appropriate Side Cover Release Kit.

**33103-03A**

Fits '01-'05 Dyna models. Requires separate purchase of appropriate Side Cover Release Kit.

### Shown with:

#### SCREAMIN' EAGLE TRANSMISSION SIDE COVER FOR 6-SPEED TRANSMISSION

Includes unique side cover and clutch components required for installing a Screamin' Eagle 6-Speed Transmission.

**38753-04A** Hydraulic Clutch.

Fits '99-'05 Dyna, '00-'06 Softail and '99-'06 Touring models equipped with Screamin' Eagle 6-Speed Transmission and Hydraulic Clutch. NOTE: If installing a Hydraulic Clutch on a previously installed Screamin' Eagle 6-Speed, separate purchase of the Clutch Release Cover Gasket P/N 35148-03 is required.

**38752-04** Cable Clutch.

Fits '91-'05 Dyna and '90-'06 Softail and Touring models equipped with Screamin' Eagle 6-Speed Transmission and cable-actuated clutch.

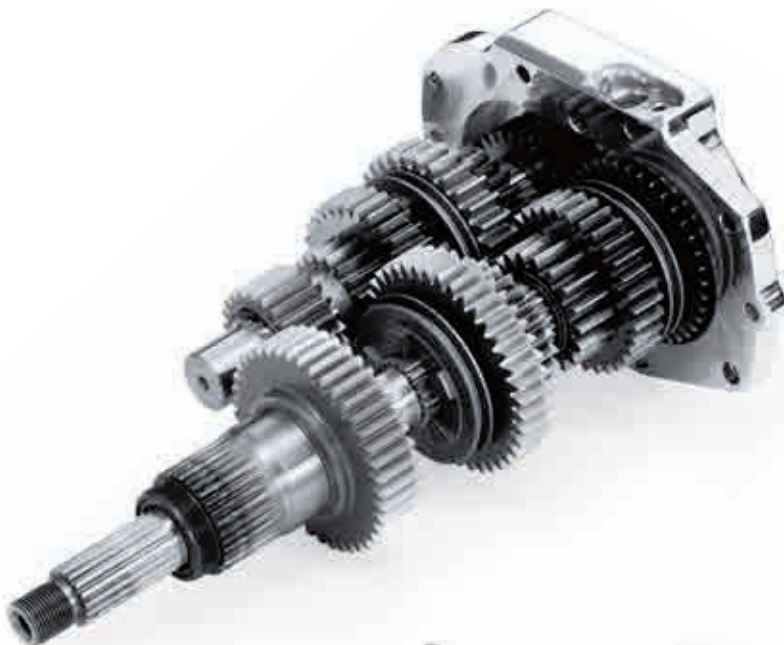
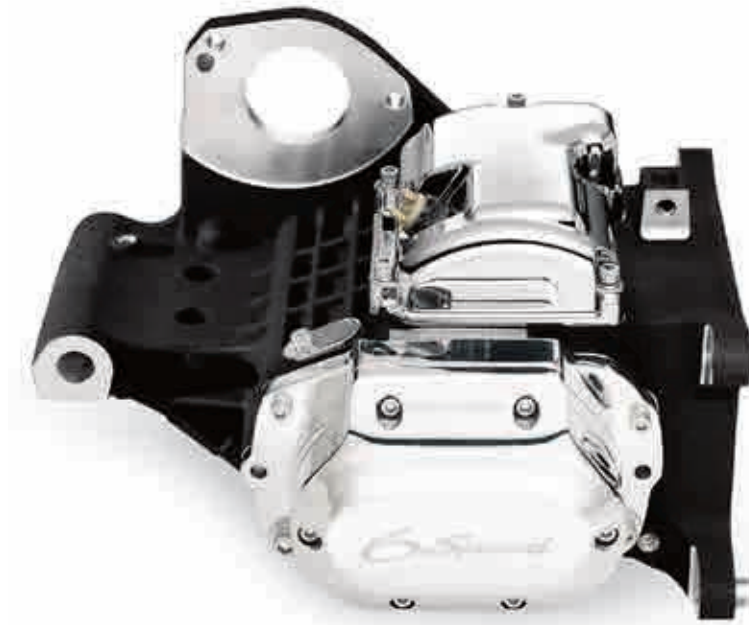

The Screamin' Eagle 6-Speed Transmission has been tested and validated using the same rigorous procedures that Original Equipment transmissions are subjected to and is backed by a 12 or 24-month (depending on model year) unlimited mileage warranty when installed at the time of a new bike purchase.

## E. SCREAMIN' EAGLE 6-SPEED TRANSMISSION AND GEAR SET (SHOWN WITH SCREAMIN' EAGLE TRANSMISSION SIDE COVER FOR 6-SPEED TRANSMISSION)

Not all products are available in all countries – please consult your dealer for details.

## HARLEY-DAVIDSON® LONGBLOCK PROGRAM

Your engine is the heart and soul of your Harley-Davidson® motorcycle. When the miles start to add up, a Harley-Davidson LongBlock can put the rumble back in your ride simply, quickly, and affordably.

**WHY SHOULD I CONSIDER A LONGBLOCK?** Unlike an engine rebuild from the repair shop down the street, the Harley-Davidson LongBlock is manufactured from 100% new Original Equipment components, and is built to the latest factory specifications. Engine includes upgraded Screamin' Eagle® lefty crankcase bearing, Screamin' Eagle cam bearings and Screamin' Eagle performance tappets to handle higher stress loads and performance upgrades. In addition, '99-'06 LongBlocks are upgraded with late-model hydraulic cam tensioners, high-volume oil pump and billet cam plate. '07-'13 103CI and 110CI engines feature factory-installed Automatic Compression Releases.

**WHAT DOES THE H-D® LONGBLOCK INCLUDE?** The crankcase is pre-assembled with flywheels, connecting rods, bearings, seals, cylinders, pistons, rings, heads, valves, valve springs, tappets and pushrod covers. Also included and ready for Dealer installation are top end rocker arm supports, rocker arms and shafts, pushrods, and breathers. The LongBlock also includes cam support plate, cam plate bearings, cam and timing chain drive, hydraulic tensioners and all required gaskets and new hardware.

**WHAT ELSE DO I NEED?** LongBlock is sold without cam shafts, lower rocker boxes, upper rocker box covers, or cam cover. You have the option to re-install your current cams and covers, or select from a wide assortment of performance and custom engine cover options.

**FAST AND EASY:** Just take your Harley® motorcycle to your authorized dealership. They will remove the engine from the frame, ship the left crankcase half to Harley-Davidson, and in a short time, you will have a new LongBlock back, ready for the dealer to reinstall in your bike. Your engine retains its original Vehicle Identification Number (VIN) for easy title exchange and registration.



### Available to fit:

#### '00-'06 Softail® models.

16200087 Twin Cam 88® – Black.

16200088 Twin Cam 88 – Silver.

#### '01-'06 EFI Softail models.

16200093 Twin Cam 95 – Black.

16200094 Twin Cam 95 – Silver.

#### '05-'06 EFI Softail models.

16200097 Twin Cam 103™ – Black.

16200098 Twin Cam 103 – Silver.

#### '07-'14 Softail models.

16200101 Twin Cam 96™ – Black.

16200102 Twin Cam 96 – Silver.

16200104 Twin Cam 103 – Black.

16200108 Twin Cam 110™ – Black.

16200109 Twin Cam 110 – Granite.

#### '99-'05 Dyna® and '99-'06 Touring models.

16200085 Twin Cam 88 – Black.

16200086 Twin Cam 88 – Silver.

#### '04-'05 EFI Dyna and '99-'06 EFI Touring models.

16200091 Twin Cam 95 – Black.

16200092 Twin Cam 95 – Silver.

#### '03-'06 EFI Touring models.

16200095 Twin Cam 103 – Black.

16200096 Twin Cam 103 – Silver.

#### '06-'14 Dyna and '07-'14 Touring models.

16200099 Twin Cam 96 – Black.

16200100 Twin Cam 96 – Silver.

#### '07-'14 Dyna and '07-'14 Touring models.

16200103 Twin Cam 103 – Black.

16200105 Twin Cam 110 – Black.

16200106 Twin Cam 110 – Granite.

### Also available:

#### ENGINE COVER KITS

Finish your LongBlock engine installation in style. Kit includes 2 upper and lower rocker box covers and matching cam cover.

**Fits '01-later Dyna®, '01-later Softail® and '01-later Touring (except '01 EFI Touring) and '09-later Trike models.**

92500025 Chrome.

92500026 Gloss Black.

92500027 Wrinkle Black.



### LONGBLOCK – '99-'06 MODELS (DYNA®/TOURING SHOWN)

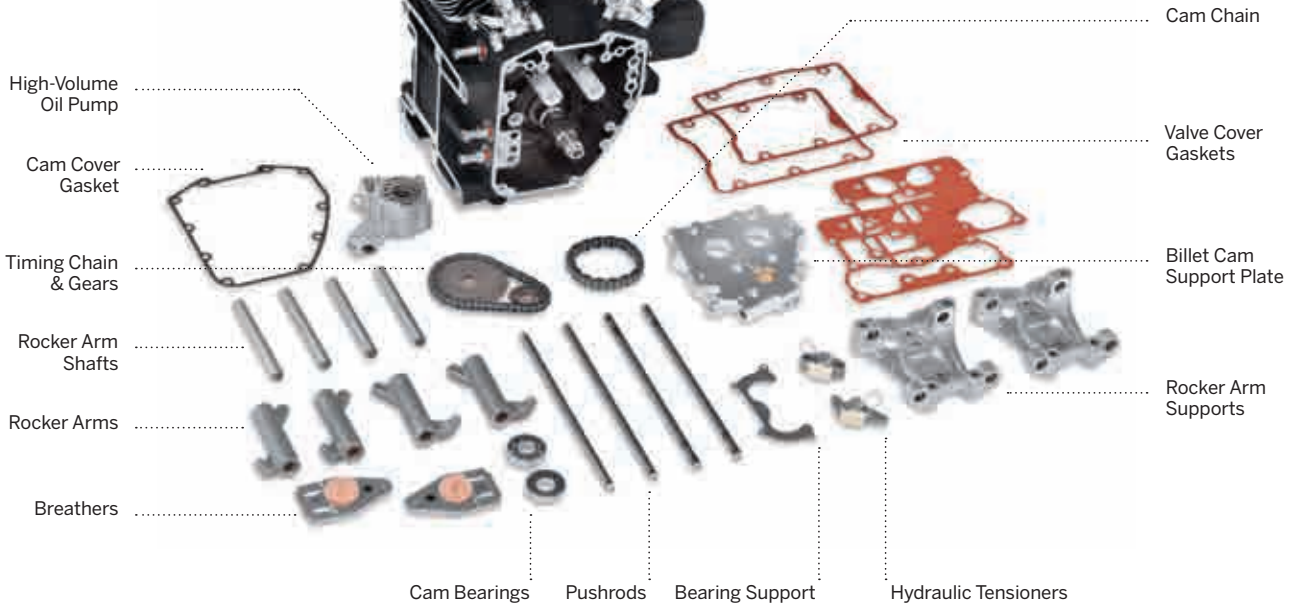

### LONGBLOCK – '07-'13 MODELS (DYNA/TOURING SHOWN)

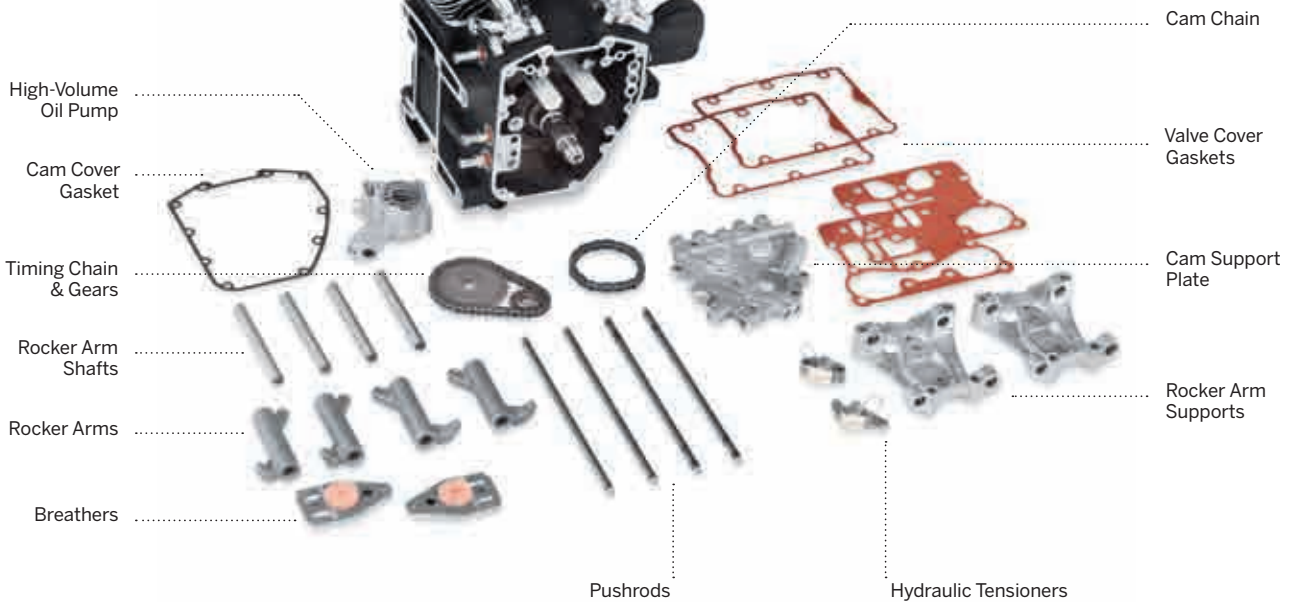

**NOTE:** All fasteners are included but not shown.

*Not all products are available in all countries – please consult your dealer for details.*