

WINSMITH



SE ENCORE™
Unique, Powerful Performance

WORM GEAR SPEED REDUCERS

SE Encore... Unique, Powerful Performance



UNIQUE OPEN-CLOSE VENT allows flexibility for the reducer to be properly applied indoors or out, in wet, dusty, or dirty environments.



POWERFUL NEW RATINGS:

- SE Encore proprietary gear design
- Mobil Glygoyle 460 lubricant* filled to the proper level
- Recess action gearing for higher efficiency
- High pressure angle for higher efficiency

*Glygoyle is a registered trademark of Exxon Mobil Corporation or one of its subsidiaries.

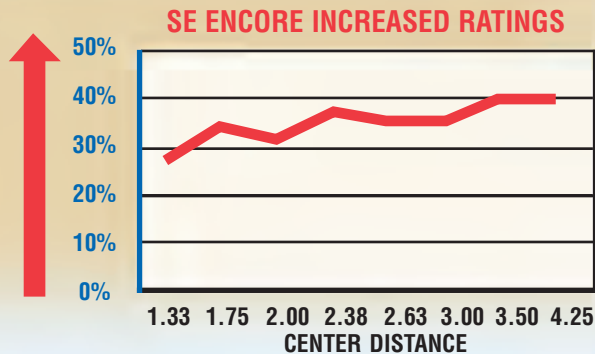

NEW PERFORMANCE STANDARD with WinGuard™ Epoxy Coating System is tested and proven to be tough, durable, chip, nick, scratch resistant and suitable for high-pressure wash down and outdoor applications. The WinGuard Epoxy Coating System withstands over 1,000 hours of salt spray testing and resists severe duty environmental conditions.



RELIABLE LONG LIFE OPERATION

- All covers are sealed with O-rings
- All seal surfaces are plunge ground
- All input seals on quill input adaptors use higher temperature rated seals for longer life
- All reducers are 100% leak tested with a state of the art mass flow computerized system
- An internal vent shield is located above the worm and blocks oil from spraying directly toward the vent location
- Square male plugs for the vent, level, and drain locations allow easy removal
- Anti-seize compound installed in the worm bore to minimize fretting corrosion
- Push-off holes are threaded into a reinforced section of the motor flange for ease of removal
- Puller slots are located on both sides of all hollow output shafts for easy reducer removal



SE Encore... Worm Gear Speed Reducer Solutions



MULTIMOUNT

Immediate Availability Solutions

- WinGuard Black Epoxy Coating System
- Quill Input Adaptor
- Solid Output Shaft(s) (Standard Diameter)
- Hollow Output Shafts (Max Standard Bore)
- Bushing Kits
- Base Kits
- Bracket Kits
- Helical or Worm Gear Ratio Multiplier

INTEGRAL

Assembled And Ready To Use Solutions

- WinGuard Black or White Epoxy Coating System
- Quill or Coupling Input Adaptor or Solid Input Shaft
- Solid Output Shaft(s)
- Hollow Output Shafts (Bored to Size or with Bushing)
- Base Attached
- Double Reduction Worm or Helical Primary

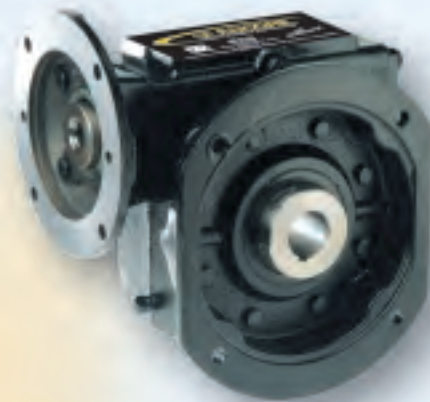

MODIFIED

Engineered Special Solutions

- WinGuard Black or White Epoxy Coating System
- Special Input Shafts
- Special Input Quill and Coupling Adaptors
- Special Solid Output Shafts
- Special Hollow Output Shafts (Bored to Size or with Bushing)
- Special Ratios
- Special Bases and Brackets
- Special Output Flanges

SE ENCORE AVAILABILITY

MULTIMOUNT 24 hours!

INTEGRAL 1 Day to 4 Weeks

MODIFIED 1 to 8 Weeks

0 1 2 3 4 5 6 1 1 2 3 4 5 6 2 1 2 3 4 5 6 3 1 2 3 4 5 6 4 1 2 3 4 5 6 5 1 2 3 4 5 6 6 1 2 3 4 5 6 7 1 2 3 4 5 6 8



2D DRAWINGS & 3D MODELS
www.WINSMITH.com



SE Encore... Nomenclature

OVERVIEW

SIZE (Center Distance)	MODEL	ASSEMBLY DESIGNATION	INPUT ADAPTOR	STANDARD HOLLOW OUTPUT BORE	SINGLE REDUCTION RATIO*	DOUBLE REDUCTION RATIO*
E13 - 1.330"	SOLID OUTPUT SHAFT MODEL EXAMPLES XDNS - Solid Input, Solid Output, Housing Mount, Single Reduction MDNS - Quill Input Adaptor, Solid Output, Housing Mount, Single Reduction CDNS - Coupled Input Adaptor, Solid Output, Housing Mount, Single Reduction XDTS - Solid Input, Solid Output, Base Mount, Single Reduction MDTS - Quill Input Adaptor, Solid Output, Base Mount, Single Reduction CDTS - Coupled Input Adaptor, Solid Output, Base Mount, Single Reduction HOLLOW OUTPUT SHAFT MODEL EXAMPLES XDSS - Solid Input, Hollow Output, Housing Mount, Single Reduction MDSS - Quill Input Adaptor, Hollow Output, Housing Mount, Single Reduction CDSS - Coupled Input Adaptor, Hollow Output, Housing Mount, Single Reduction XSFS - Solid Input, Hollow Output, Flange Mount, Single Reduction MSFS - Quill Input Adaptor, Hollow Output, Flange Mount, Single Reduction CSFS - Coupled Input Adaptor, Hollow Output, Flange Mount, Single Reduction	Solid Output	42C	E17 - 1.000"	4	38
E17 - 1.750"		L - Left	56C	E20 - 1.438"	5	50
E20 - 2.000"		R - Right	140TC	E24 - 1.500"	7.5	60
E24 - 2.375"		LR - Left & Right	180TC	E26 - 1.688"	10	75
E26 - 2.625"		Hollow Output	210TC	E30 - 1.938"	15	90
E30 - 3.000"			DLR - Left & Right	E35 - 2.188"	20	100
E35 - 3.500"			E43 - 2.750"	25	120	3600
E43 - 4.250"			30	150	4000	
			40	180	5000	
			50	200	6000	
	60		250	8000		
	80			10000		
	100					

* Nominal ratio. For exact ratio see ratings tables.

EXAMPLES

E24 XSJS DLR 40 1.125" - Bushing



Hollow Output Bore Dimension
(final dimension achieved by bushing, see chart on page 16)

Gear Reduction Ratio

Symmetrical Hollow Output Shaft

Model - "J" Vertical, Solid Input Shaft (Non-Motorized),
Hollow Output Shaft, Bracket Mount, Single Reduction

SE Encore Series Reducer - 2.375" Center Distance

E30 CDTS L 140TC 80



Gear Reduction Ratio

Input Adaptor

Left Hand Assembly Solid Output Shaft

Model - Worm on Top, Coupled Input Adaptor,
Solid Output Shaft, Base Mount, Single Reduction

SE Encore Series Reducer - 3.00" Center Distance

SE Encore Series Introduction

Worm Gear Speed Reducers Solutions	3
Nomenclature	4
Warnings	8

SE Encore Multimount Worm Gear Speed Reducers 9

Ratings Summary	11	Vertical Input	20
Selection by Input Horsepower ...	12	Flange Output	21
MDNS Model Information	14	Hanger Bracket	22
MDSS Model Information	15	Torque Arm	23
Accessory Kits		Industry Interchange Base Plate	24
Hollow Output Shaft Bushings	16	Worm Gear Ratio Multiplier.....	25
Quill Input Shaft Bushings.....	17	Selection by Input Horsepower	26
Hollow Shaft Covers	17	MDDS Model Information	27
Mounting Kits		Helical Gear Ratio Multiplier.....	28
Worm on Top.....	18	MHDS Model Information	29
Worm on Bottom.....	19	MHDS Ratings.....	29

SE Encore Integral Worm Gear Speed Reducers 30

Single Reduction Models Quick Select	32
Single Reduction Models Information	36
Helical/Worm Double Reduction Models Quick Select	68
Helical/Worm Double Reduction Models Information	72
Worm/Worm Double Reduction Models Quick Select	86
Worm/Worm Double Reduction Models Information	90
Accessories.....	104
Hollow Output Shaft Bushings	104
Quill Input Bushings	105
Hollow Shaft Covers	105
Flexible Couplings.....	106
Coupled Input Adaptor	106
Input Cap and Output Cover Bolt Patterns	107
Lubricant Levels and Special Mounting Positions.....	108





SE Encore Modified Worm Gear Speed Reducers	110
Modified Worm Gear Examples	111
Double Extended Input Shafts	114
Servo Motor Adaptors	115
Servo Motor Adaptor Capability - Square Face	116
Servo Motor Adaptor Capability - Round Face	117
Metric Speed Reducers	119
Modified Output Shaft Options	122
Solid Output Shaft Extensions and Modifications	122
Hollow Output Shaft Modifications	124
Shaft Locking Devices	126
Shrink Discs	127
Tapered and Taper-Lock® Bushings	128
Seal Modifications and Combinations	129
Long Term Storage	130
Solid Lubricant Bearings	130
Modified Accessories	131
Special Bases and Brackets	131
Column and Button View Gages	131
Special Ratios, Geometry, and Left Hand Gearing	132
4:1 Ratio Speed Reducer Ratings	134
Worm Gear Ratio Multiplier	137
Drywell	143
Drywell Speed Reducer Ratings	146
SE Maximizer Series	152
SE Maximizer Plus	152
SE Maximizer Stainless Steel	152
Motion Control “S-Eliminator”	153
Hydraulic Motor Input Adaptor Rings	154



SE ENCORE TABLE OF CONTENTS (cont.)

SE Encore Worm Gear Speed Reducer Ratings	157
Ratings Summary	157
Selection by Input Horsepower	158
Single Reduction Ratings	
E13	160
E17	162
E20	164
E24	166
E26	168
E30	170
E35	172
E43	174
Double Reduction Ratings	
E17	176
E20	180
E24	184
E26	190
E30	196
E35	202
E43	208
SE Encore Appendix	214
Se Encore Worm Gear Speed Reducer Selection Criteria	215
Service Life and Catalog Ratings	215
Speed Reducer Selection Methods	216
Overhung and Thrust Load Requirements	216
Output Speed and Gear Ratio Requirements	216
Ratio Selection	217
Product Configuration	217
Environmental Requirements	217
SE Encore Series Standard Ratios	218
SE Encore Series Selection Guide	219
Speed Reducer Sealing and Venting	220
Speed Reducer Self-Locking and Back-Driving	224
SE Encore Series Lubrication	226
SE Encore Series Overhung Load and Thrust	227
SE Encore Series Thermal Limit Ratings	229
Speed Reducer Backlash	230
Speed Reducer Efficiency and Run-in	232
Service Factor Section	233
Useful Formulas, Conversions, and Motor Mounting Dimensions	
Resource Guide and Conversion Tables	237
Useful Formulas	238
NEMA and IEC Frame Reference Dimensions	239
Speed Reducer Specification Sheet	240
Warnings and Cautions	243
Terms and Conditions of Sale	245
Winsmith History	246





WARNING

This catalog provides general guidance and assistance for making the proper product selection for an application. While the information in this catalog is believed to be accurate, it is based on specific laboratory tests, calculations, and assumptions, and not actual field conditions or applications. It does not represent a guarantee with respect to characteristics or performance of the product in any given application or use. Winsmith products, and associated equipment and machinery, are intended for selection, installation and use by trained and skilled persons capable of determining their suitability for the specific application or use. Proper selection, installation, operation and maintenance, including implementation of adequate safety measures, are the responsibility of the purchaser or user. PEERLESS-WINSMITH MAKES NO WARRANTY OF MERCHANTABILITY OR FITNESS FOR A PARTICULAR PURPOSE OR ANY OTHER WARRANTY, EXPRESS OR IMPLIED, EXCEPT AS IS EXPRESSLY SET IN ITS TERMS AND CONDITIONS OF SALE. PEERLESS-WINSMITH SHALL NOT BE LIABLE FOR INCIDENTAL OR CONSEQUENTIAL DAMAGES. See the terms and conditions of sale (page 245) for further details.

The Appendix to this catalog contains important information regarding **Winsmith** products, including selection, application, operation, and service factor information. Please review it and other available guidance carefully before selecting or recommending a gear reducer for any application.

Information in this catalog is subject to revision without notice. Visit **www.WINSMITH.com** or contact a Winsmith representative for the most current product information.

SE Encore Multimount Worm Gear Speed Reducers

AVAILABLE IN 24 HOURS!

- WinGuard™ Black Epoxy Coating System
- Quill Input Adaptor
- Solid Output Shaft(s) (Standard Diameter)
- Hollow Output Shafts (Max Standard Bore)
- Bushing Kits
- Base Kits
- Bracket Kits
- Helical or Worm Gear Ratio Multiplier



MULTIMOUNT PRODUCT NOMENCLATURE OVERVIEW

SIZE (Center Distance)	MODEL	RATIO	ASSEMBLY DESIGNATION	QUILL INPUT ADAPTOR	STANDARD HOLLOW OUTPUT SHAFT BORE SIZES
E13 – 1.333"	MDNS	5	Solid Output Shaft	56C	E13 - NA
E17 – 1.750"	MDSS	10	R - Right	140TC	E17 - 1.000"
E20 – 2.000"		15	L - Left	180TC	E20 - 1.438"
E24 – 2.375"		20	LR - Left & Right	210TC	E24 - 1.500"
E26 – 2.625"		25			E26 - 1.688"
E30 – 3.000"		30	Hollow Output Shaft		E30 - 1.938"
E35 – 3.500"		40	DLR - Left & Right		E35 - 2.188"
E43 – 4.250"		50			E43 - 2.750"
		60			

SE Encore Multimount Worm Gear Speed Reducers Table of Contents

Ratings Summary	11
Selection by Input Horsepower	12
MDNS Model Information	14
MDSS Model Information	15
Accessory Kits	
Hollow Output Shaft Bushings	16
Quill Input Shaft Bushings	17
Hollow Shaft Covers	17
Mounting Kits	
Worm on Top	18
Worm on Bottom	19
Vertical Input	20
Flange Output	21
Hanger Bracket	22
Torque Arm	23
Industry Interchange Base Plate	24
Worm Gear Ratio Multiplier	25
Selection by Input Horsepower	26
MDDS Model Information	27
Helical Gear Ratio Multiplier	28
MHDS Model Information	29
MHDS Ratings	29

SE ENCORE MULTIMOUNT WORM GEAR SPEED REDUCERS

SE Encore Multimount worm gear speed reducers are supplied as a component system consisting of a hollow or solid output shaft *universal mount* reducer and one or more *accessory kits* (if needed). The combination creates a quickly and easily configurable set of product offerings and reduction combinations. SE Encore Multimount worm gear speed reducers are available in most common ratios with quill input adaptors. Also available are Multimount Worm and Helical Gear Ratio Multipliers. These reducers can function as “stand alone” products or when used in combination with a universal mount reducer, they dramatically expand the torque and reduction capabilities of the SE Encore Multimount product line.

All SE Encore Multimount worm gear speed reducers are filled to a single lubricant level, designed such that the speed reducer can be successfully operated in any mounting position *without* adjusting the lubricant level. Additionally, the SE Encore Multimount worm gear speed reducer can be sealed during operation in many intermittent applications, but each is also supplied with an easy optional open-close vent kit for heavy or continuous duty applications.* All SE Encore Multimount speed reducers can be shipped from Winsmith within 24 hours.

* See “Appendix” section of this catalog for more details.



2D DRAWINGS & 3D MODELS
www.WINSMITH.com



SE Encore Multimount Worm Gear Speed Reducers

MULTIMOUNT CONFIGURATION PROCEDURE SIZE

Identify the three digit nomenclature for size appearing in the selection pages of this catalog section.

Example: 1HP input, 30:1 gear reduction, 1750 RPM, 1.25 service factor yields a 2.375" center distance speed reducer. The nomenclature for the size of this reducer is "E24."

MODEL

Identify one of two *universal mount* speed reducer models that are available as part of the Multimount component system: Each is identified in the table below and at the top of the corresponding dimension page in this section by a complete description and by the four letter (e.g. MDNS) model nomenclature.

MODEL	MODEL DESCRIPTION
MDNS	Quill input adaptor, solid output shaft
MDSS	Quill input adaptor, hollow output shaft
MDDS	Worm Gear Ratio Multiplier Quill input adaptor, flanged with solid output shaft
MHDS	Helical Gear Ratio Multiplier Quill input flange, flanged with solid output shaft

RATIO

Identify the required ratio in full format (i.e. 30:1), or in brief format (i.e. 30).

ASSEMBLY

Identify the relative position of the input shaft and the output shaft for a Multimount reducer. The dimension pages of this section contain the possible selections for each speed reducer size. **Example:** The nomenclature for an MDNS with right-hand and left-hand standard output shaft extensions is "LR."

QUILL INPUT ADAPTOR

SE Encore Multimount products are assembled with NEMA 56C, 140TC, 180TC, or 210TC compatible input

MULTIMOUNT PRODUCT NOMENCLATURE EXAMPLES

SIZE	MODEL	RATIO	ASSEMBLY	QUILL INPUT ADAPTOR	HOLLOW OUTPUT SHAFT BORE SIZE	ACCESSORY KIT	COMPLETE NOMENCLATURE
E20	MDNS	50	L	56C		Vertical Input Bracket Mount	E20 MDNS 50 L 56C JK9998029
E24	MDSS	60	DLR	56C	1.500"	Output Bushing Kit for 1.000" Bore	E24 MDSS 60 DLR 56C 1.500" Output Bushing for 1.000" Output Bore
E26	MDNS	10	R	140TC		Horizontal Output, Bracket Mount	E26 MDNS 10:1 R 140TC Horizontal Output Bracket
E30	MDSS	5	DLR	180TC	1.938"	Worm on Top, Base Mount	E30 MDSS 5 DLR 180TC 1.938" Base Kit
E20	MDNS	30	L	56C		206, 5:1 Helical	E20 MDNS 30 L 56C with Helical 206, 5:1 Multiplier

*See "venting" section of this catalog for more details.

**For some 56C and 180TC assemblies, an input adaptor bushing may be supplied to accommodate the correct motor shaft requirement.

adaptors.** The dimension pages in this section contain the possible selections for each speed reducer size.

HOLLOW OUTPUT SHAFT BORE SIZE

Identify the hollow output shaft bore size of an MDSS using the tables on page 15 of this section. Express the bore size as a decimal (Example = 1.438"). Specify a Hollow Output Shaft Bushing Kit (page 16) to accommodate a wide variety of output shaft requirements. These kits are shipped with the Multimount speed reducer and require assembly.

WORM AND HELICAL GEAR RATIO MULTIPLIERS

Worm and Helical Gear Ratio Multipliers offer an expedient method of easily creating multiple stage ratio reductions by using them in combination with any *universal mount* reducer. Both have a machined register output adaptor that is machined to a NEMA tolerance of 0.003 inches providing a precision interface with the driven equipment. This can be very useful especially in motion control applications. The Worm Gear Ratio Multiplier is available in standard reductions of 5:1 to 60:1 and is configurable as either a left (L) or a right (R) assembly. The Helical Worm Gear Multiplier is available in 5:1 and 6:1 reductions. Both are equipped with a quill input adaptor and a solid output shaft. See page 25 for nomenclature information.

ACCESSORY KITS

The available *accessory kits* described in the Multimount section of the catalog (see "Kits" starting on page 16) can be combined with a *universal mount* reducer. These add-on items are identified either as a description or by a kit part number. An *accessory kit* specification should follow the *universal mount* reducer specifications. When adding a Multimount Worm Gear Ratio Multiplier or a Helical Gear Ratio Multiplier, specify these as an *accessory kit*. **Example:** To include a kit on an E20 MDNS that allows vertical mounting of the input shaft, the specification would be, "vertical input, bracket mount kit" (also known as "J" mount), or the kit number JK9998029.

Ratings Summary[▲]

INPUT MOTOR HORSEPOWER AND TORQUE RATINGS (lbf-in.) AT 1750 RPM INPUT

1.00 SERVICE FACTOR*

REDUCER SIZE	RATIO ¹		5	10	15	20	25	30	40	50	60
	OUTPUT RPM		350	175	117	88	70	58	44	35	29
	RATINGS AT 1750 RPM INPUT ²										
E13	Page # 160-161	HP	1.39	0.86	0.62	0.42	0.41	0.35	0.27	0.17	0.15
		Torque	238	284	295	257	304	293	276	213	202
E17	Page # 162-163	HP	2.69	1.64	1.15	0.94	0.70	0.66	0.52	0.41	0.27
		Torque	462	554	568	604	547	596	603	558	417
E20	Page # 164-165	HP	3.70	2.24	1.59	1.24	1.01	0.86	0.68	0.56	0.41
		Torque	639	769	794	806	803	788	795	791	656
E24	Page # 166-167	HP	5.89	3.67	2.71	2.11	1.61	1.45	1.11	0.92	0.70
		Torque	1017	1249	1359	1383	1285	1360	1335	1329	1134
E26	Page # 168-169	HP	7.70	4.82	3.42	2.64	2.17	1.80	1.42	1.18	0.92
		Torque	1334	1650	1724	1745	1758	1712	1737	1748	1556
E30	Page # 170-171	HP	10.87	7.11	5.07	3.95	3.24	2.67	2.08	1.72	1.34
		Torque	1886	2448	2578	2645	2676	2586	2617	2643	2367
E35	Page # 172-173	HP	15.82	10.27	7.51	5.73	4.71	4.07	3.04	2.44	2.00
		Torque	2738	3515	3804	3821	3884	3943	3837	3753	3573
E43	Page # 174-175	HP	25.16	15.84	11.63	9.16	7.50	6.40	4.94	3.96	3.23
		Torque	4382	5400	5819	6007	5981	6013	6005	5852	5566

INPUT HORSEPOWER AND TORQUE RATINGS (lbf-in.) AT 1160 RPM INPUT

1.00 SERVICE FACTOR*

REDUCER SIZE	RATIO ¹		5	10	15	20	25	30	40	50	60
	OUTPUT RPM		232	116	77	58	46	39	29	23	19
	RATINGS AT 1160 RPM INPUT ²										
E13	Page # 160-161	HP	1.06	0.65	0.48	0.30	0.31	0.27	0.18	0.13	0.11
		Torque	276	320	342	271	345	341	291	237	224
E17	Page # 162-163	HP	2.16	1.24	0.78	0.67	0.47	0.48	0.39	0.28	0.19
		Torque	562	632	571	645	554	660	676	564	435
E20	Page # 164-165	HP	2.85	1.68	1.06	0.91	0.73	0.66	0.51	0.41	0.27
		Torque	743	863	788	891	865	920	920	882	660
E24	Page # 166-167	HP	4.81	2.55	1.81	1.60	1.05	0.94	0.73	0.63	0.46
		Torque	1263	1321	1376	1611	1280	1350	1333	1421	1138
E26	Page # 168-169	HP	5.96	3.41	2.41	1.76	1.43	1.28	1.06	0.84	0.60
		Torque	1567	1770	1847	1764	1762	1864	2028	1932	1562
E30	Page # 170-171	HP	8.75	5.31	3.35	2.70	2.19	1.95	1.59	1.29	0.88
		Torque	2303	2768	2580	2745	2749	2891	3101	3057	2381
E35	Page # 172-173	HP	12.97	8.51	6.21	4.79	3.87	3.33	2.51	1.97	1.41
		Torque	3395	4413	4771	4868	4871	4939	4871	4695	3863
E43	Page # 174-175	HP	21.19	13.06	9.66	7.69	6.24	5.32	4.09	3.27	2.58
		Torque	5541	6666	7211	7511	7402	7467	7515	7345	6742

Note: For ratings of 1.25 service factors and 1.50 service factors, please refer to page 160 of the Ratings section.

* For thermal limit ratings of 1.25 service factors and 1.50 service factors, please contact Winsmith.

1. Exact ratio

2. If input speed is below 1160 RPM, please specify speed and mounting position to ensure proper lubrication.

■ Mechanical ratings shaded above exceed speed reducer thermal limitations under continuous duty conditions. Refer to Appendix (page 229) for Continuous Duty Thermal Limit Ratings.

▲ See Ratings Summary (page 160) for additional ratios.



2D DRAWINGS & 3D MODELS
www.WINSMITH.com



Selection By Input Horsepower

REDUCER SIZE AND TORQUE (lbf·in.) AT 1750 RPM INPUT ²

1.00 SERVICE FACTOR

OUTPUT RPM	RATIO ¹	HP	INPUT HORSEPOWER										
			0.25	0.33	0.50	0.75	1.00	1.50	2.00	3.00	5.00	7.50	10.00
350	5	SIZE			E13	E13	E13	E17	E17	E20	E24	E26	E43
		TORQUE			86	128	171	258	343	518	863	1299	1742
175	10	SIZE		E13	E13	E13	E17	E17	E20	E24	E30	E35	E43
		TORQUE		109	165	248	338	507	687	1021	1722	2567	3409
117	15	SIZE		E13	E13	E17	E17	E20	E24	E26	E30	E35	E43
		TORQUE		157	238	370	494	749	1003	1512	2542	3799	5003
88	20	SIZE	E13	E13	E17	E17	E20	E24	E24	E30	E35	E43	
		TORQUE	153	202	321	483	650	983	1311	2009	3334	4918	
70	25	SIZE	E13	E13	E17	E20	E20	E24	E26	E30	E43	E43	
		TORQUE	185	245	391	596	795	1197	1620	2478	3987	5981	
58	30	SIZE	E13	E13	E17	E20	E24	E26	E30	E35	E43		
		TORQUE	209	276	452	687	938	1427	1937	2906	4698		
44	40	SIZE	E13	E17	E17	E24	E24	E30	E30	E35			
		TORQUE	256	383	580	902	1203	1887	2516	3787			
35	50	SIZE	E17	E17	E20	E24	E26	E30	E35	E43			
		TORQUE	340	449	706	1083	1481	2305	3076	4433			
29	60	SIZE	E17	E20	E24	E26	E30	E35	E35	E43			
		TORQUE	386	525	810	1268	1766	2680	3573	5170			

REDUCER SIZE AND TORQUE (lbf·in.) AT 1750 RPM INPUT ²

1.25 SERVICE FACTOR

OUTPUT RPM	RATIO ¹	HP	INPUT HORSEPOWER										
			0.25	0.33	0.50	0.75	1.00	1.50	2.00	3.00	5.00	7.50	10.00
350	5	SIZE			E13	E13	E13	E17	E17	E20	E26	E30	E43
		TORQUE			86	128	171	258	343	518	866	1301	1712
175	10	SIZE		E13	E13	E17	E17	E20	E24	E26	E30	E35	E43
		TORQUE		109	165	253	338	515	680	1026	1722	2567	3410
117	15	SIZE		E13	E13	E17	E20	E24	E24	E30	E35	E43	
		TORQUE		157	238	370	500	751	1003	1524	2532	3753	
88	20	SIZE	E13	E13	E17	E17	E20	E24	E26	E30	E43		
		TORQUE	153	202	321	483	650	983	1322	2009	3279		
70	25	SIZE	E13	E13	E17	E20	E24	E26	E30	E35	E43		
		TORQUE	185	245	391	596	798	1215	1653	2472	3987		
58	30	SIZE	E13	E17	E17	E24	E24	E30	E30	E35	E43		
		TORQUE	209	298	452	703	938	1450	1937	2906	4698		
44	40	SIZE	E17	E17	E20	E24	E26	E30	E35	E43			
		TORQUE	290	383	585	902	1223	1887	2524	3647			
35	50	SIZE	E17	E17	E24	E24	E30	E35	E35	E43			
		TORQUE	340	449	722	1083	1537	2307	3076	4433			
29	60	SIZE	E20	E20	E24	E26	E30	E35	E43				
		TORQUE	400	525	810	1268	1766	2680	3446				

1. Exact ratio

2. If input speed is below 1160 RPM, please specify speed and mounting position to ensure proper lubrication.

☐ Mechanical ratings shaded above exceed speed reducer thermal limitations under continuous duty conditions.

Refer to Appendix (page 229) for Continuous Duty Thermal Limit Ratings.

Selection By Input Horsepower

REDUCER SIZE AND TORQUE (lbf·in.) AT 1750 RPM INPUT ²

1.50 SERVICE FACTOR

OUTPUT RPM	RATIO ¹	HP	INPUT HORSEPOWER										
			0.25	0.33	0.50	0.75	1.00	1.50	2.00	3.00	5.00	7.50	10.00
350	5	SIZE			E13	E13	E17	E17	E20	E24	E26	E35	E43
		TORQUE			86	128	171	258	345	518	866	1298	1712
175	10	SIZE		E13	E13	E17	E17	E20	E24	E26	E35	E43	E43
		TORQUE		109	165	253	338	515	680	1026	1711	2557	3410
117	15	SIZE		E13	E17	E17	E20	E24	E26	E30	E35	E43	
		TORQUE		157	247	370	500	751	1008	1524	2532	3753	
88	20	SIZE	E13	E17	E17	E20	E24	E26	E30	E35	E43		
		TORQUE	153	212	321	488	655	991	1339	2001	3279		
70	25	SIZE	E13	E17	E20	E24	E24	E26	E30	E35	E43		
		TORQUE	185	258	398	599	798	1215	1653	2472	3987		
58	30	SIZE	E17	E17	E20	E24	E24	E30	E35	E43			
		TORQUE	226	298	458	703	938	1450	1938	2819			
44	40	SIZE	E17	E17	E24	E24	E26	E35	E35	E43			
		TORQUE	290	383	601	902	1223	1893	2524	3647			
35	50	SIZE	E17	E20	E24	E26	E30	E35	E43				
		TORQUE	340	466	722	1111	1537	2307	2956				
29	60	SIZE	E20	E24	E26	E30	E35	E43	E43				
		TORQUE	400	535	846	1325	1787	2585	3446				

1. Exact ratio

2. If input speed is below 1160 RPM, please specify speed and mounting position to ensure proper lubrication.

MODEL	QUILL INPUT ADAPTOR SIZES	ADDITIONAL STANDARD RATIOS
E13	56C, 140TC	4; 7.5
E17	56C, 140TC	4; 7.5; 80; 100
E20	56C, 140TC	4; 7.5; 80; 100
E24	56C, 140TC, 180TC	4; 7.5; 80; 100
E26	56C, 140TC, 180TC	4; 7.5; 80; 100
E30	56C, 140TC, 180TC	4; 7.5; 80; 100
E35	56C, 140TC, 180TC	4; 7.5; 80; 100
E43	56C, 140TC, 180TC, 210TC	4; 7.5; 80; 100

For additional standard ratios see rating page 160.

Multimount



2D DRAWINGS & 3D MODELS
www.WINSMITH.com



MDNS Model Information

Universal Quill Input Adaptor Solid Output Shaft Housing Mount

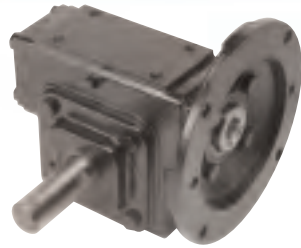

L Assembly



LR Assembly



R Assembly

DIMENSIONS

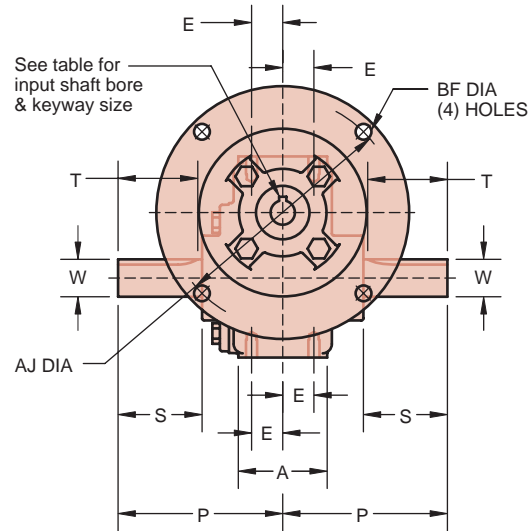
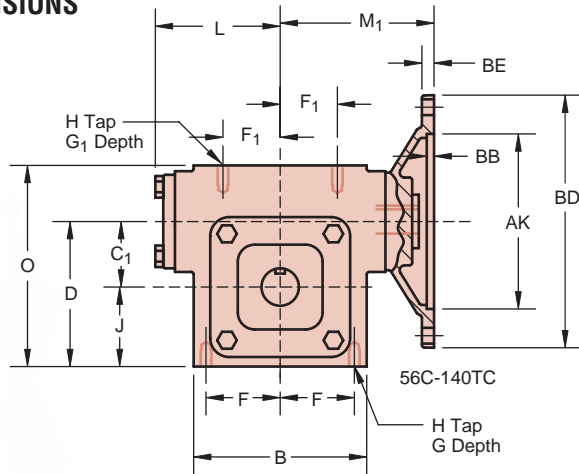

INPUT ADAPTOR DIMENSIONS (in.)

INPUT ADAPT. DIM.	56C	140TC	180TC	210TC
AJ	5.88	5.88	7.25	7.25
AK	4.50	4.50	8.50	8.50
BB	.19	.19	.19	.19
BD	6.50	6.50	9.00	9.00
BE	.31	.31	.38	.38
BF	.406	.406	.531	.531
KEYWAY	3/16 X 3/32		1/4 X 1/8	5/16 X 5/32
BORE ^{+0.001} / _{-.000}	.6255	.8755	1.1255	1.3755

SPEED REDUCER DIMENSIONS (in.)

Size	A	B	C ₁	D	E	F	F ₁	G DEPTH	G ₁ DEPTH	H TAP	J	L	M ₁ 56C 140TC	M ₁ 180TC	M ₁ 210TC	O	P	OUTPUT SHAFT				lb.*
																		W*	S	T	KEYWAY	
E13	2.00	3.88	1.333	3.08	.69	1.56	1.19	.56	.56	5/16-18	1.75	2.83	3.63*	NA	NA	4.33	4.00	.750	2.06	1.88	3/16 X 3/32	18
E17	2.38	4.63	1.750	3.88	.88	1.94	1.69	.63	.56	3/8-16	2.13	3.44	4.06	NA	NA	5.38	4.75	1.000	2.56	2.31	1/4 X 1/8	23
E20	2.38	5.25	2.000	4.13	.88	2.19	1.69	.63	.56	3/8-16	2.13	3.44	4.06	NA	NA	5.63	4.75	1.000	2.56	2.31	1/4 X 1/8	26
E24	3.13	5.38	2.375	5.25	1.13	2.19	2.19	.63	.57	1/2-13	2.88	4.50	5.38	5.38	NA	7.25	5.50	1.250	2.81	2.63	1/4 X 1/8	44
E26	3.13	5.88	2.625	5.75	1.13	2.44	2.44	.69	.69	1/2-13	3.13	4.50	5.38	5.38	NA	7.88	5.50	1.250	2.81	2.63	1/4 X 1/8	46
E30	3.50	6.62	3.000	6.50	1.31	2.75	2.75	.75	.75	1/2-13	3.50	4.63	5.56	5.56	NA	9.00	5.88	1.375	2.88	2.75	5/16 X 5/32	60
E35	3.75	7.69	3.500	7.50	1.31	3.25	3.25	1.00	1.00	5/8-11	4.00	5.46	5.81	5.81	NA	10.13	7.00	1.750	3.75	3.63	3/8 X 3/16	84
E43	4.38	8.75	4.250	8.63	1.63	3.75	3.75	1.00	1.00	5/8-11	4.38	6.28	6.63	6.63	6.63	11.50	8.00	2.000	4.38	4.19	1/2 X 1/4	155

* Shaft diameter tolerances +.000 -.001 ▲ 56C adaptor only ■ Approximate shipping weights
Dimensions shown are for construction purposes only. Please contact Winsmith for certified dimension sheets.



MDSS Model Information

Universal Quill Input Adaptor Hollow Output Shaft Housing Mount

DLR Assembly

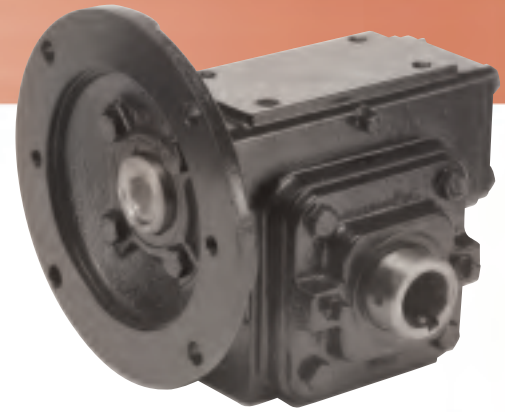

DIMENSIONS

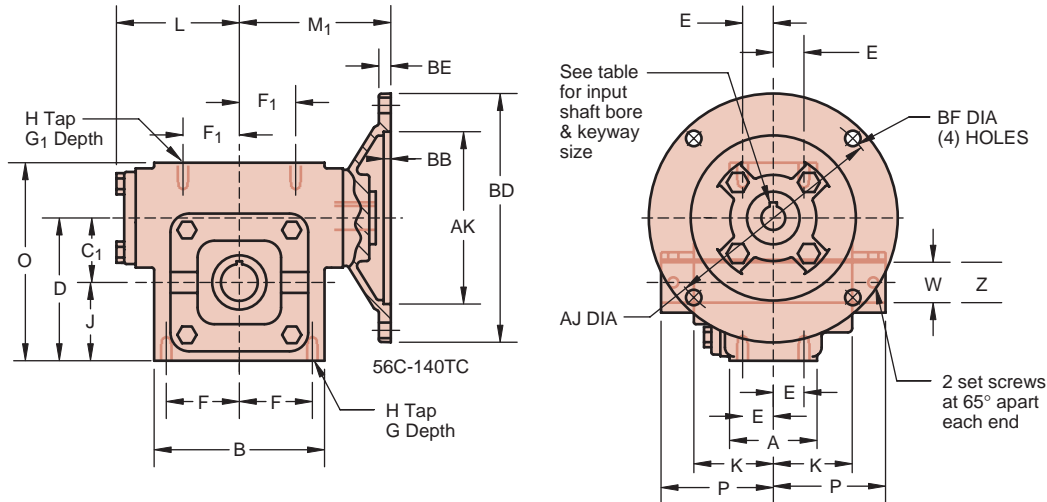

INPUT ADAPTOR DIMENSIONS (in.)

INPUT ADAPT. DIM.	56C	140TC	180TC	210TC
AJ	5.88	5.88	7.25	7.25
AK	4.50	4.50	8.50	8.50
BB	.19	.19	.19	.19
BD	6.50	6.50	9.00	9.00
BE	.31	.31	.38	.38
BF	.406	.406	.531	.531
KEYWAY	3/16 X 3/32		1/4 X 1/8	5/16 X 5/32
BORE ⁺⁰⁰¹ / _{-.000}	.6255	.8755	1.1255	1.3755

HOLLOW OUTPUT SHAFT BORES (S) STANDARD BORE (B) BUSHING

W**	KEYWAY	E17	E20	E24	E26	E30	E35	E43
.625	5/8	3/16 X 3/32	B					
.750	3/4	3/16 X 3/32	B					
.875	7/8	3/16 X 3/32	B					
1.000	1	1/4 X 1/8	S	B	B			
1.125	1-1/8	1/4 X 1/8		B	B	B		
1.188	1-3/16	1/4 X 1/8		B	B	B		
1.250	1-1/4	1/4 X 1/8		B	B	B	B	
1.375	1-3/8	5/16 X 5/32			B	B	B	
*1.438	1-7/16	3/8 X 3/16		S	B	B	B	B
1.500	1-1/2	3/8 X 3/16			S	B	B	B
1.625	1-5/8	3/8 X 3/16						
1.688	1-11/16	3/8 X 3/16				S	B	
1.750	1-3/4	3/8 X 3/16					B	B
1.875	1-7/8	1/2 X 1/4						B
*1.938	1-15/16	1/2 X 1/4					S	B
2.000	2	1/2 X 1/4						B
*2.188	2-3/16	1/2 X 1/4						S
2.250	2-1/4	1/2 X 1/4						B
2.438	2-7/16	5/8 X 5/16						B
2.750	2-3/4	5/8 X 5/16						S

**Bore tolerances +.000+.002
Two puller slots opposed on all hollow output shafts
* Bore size 1438 on size E20: keyway is 3/8 x 1/8
* Bore size 1938 on size E30: keyway is 1/2 x 3/16
* Bore size 2188 on size E35: keyway is 1/2 x 1/8

SPEED REDUCER DIMENSIONS (in.)

Size	A	B	C ₁	D	E	F	F ₁	G DEPTH	G ₁ DEPTH	H TAP	J	K	L	M ₁ 56C 140TC	M ₁ 180TC	M ₁ 210TC	O	P	Z	lb.*
E17	2.38	4.63	1.750	3.88	.88	1.94	1.69	.63	.56	3/8-16	2.13	2.44	3.44	4.06	NA	NA	5.38	3.13	1.49	25
E20	2.38	5.25	2.000	4.13	.88	2.19	1.69	.63	.56	3/8-16	2.13	2.63	3.44	4.06	NA	NA	5.63	3.31	2.00	30
E24	3.13	5.38	2.375	5.25	1.13	2.19	2.19	.63	.57	1/2-13	2.88	2.75	4.50	5.38	5.38	NA	7.25	3.44	2.25	47
E26	3.13	5.88	2.625	5.75	1.13	2.44	2.44	.69	.69	1/2-13	3.13	2.81	4.50	5.38	5.38	NA	7.88	3.50	2.50	52
E30	3.50	6.62	3.000	6.50	1.31	2.75	2.75	.75	.75	1/2-13	3.50	3.00	4.63	5.56	5.56	NA	9.00	3.69	2.63	68
E35	3.75	7.69	3.500	7.50	1.31	3.25	3.25	1.00	1.00	5/8-11	4.00	3.38	5.46	5.81	5.81	NA	10.13	4.13	2.87	90
E43	4.38	8.75	4.250	8.63	1.63	3.75	3.75	1.00	1.00	5/8-11	4.38	3.63	6.28	6.63	6.63	6.63	11.50	4.38	3.88	183

* Approximate shipping weights Dimensions shown are for construction purposes only. Please contact Winsmith for certified dimension sheets.



2D DRAWINGS & 3D MODELS
www.WINSMITH.com



Hollow Output Shaft Bushing Kits

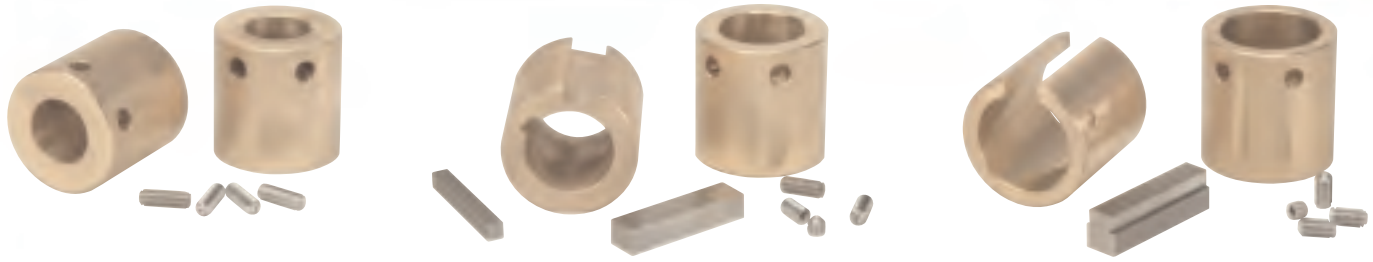

Cast Bore Bushing Kit

TYPE (C)
(2) Cast Bore Bushings

Keyed Bushing Kit

TYPE (K)
(1) Keyed Bushing
(1) Plain Bushing
(2) Drive Keys

Slotted Bushing Kit

TYPE (S)
(1) Slotted Bushing
(1) Plain Bushing
(1) Drive Key

HOLLOW SHAFT BUSHING CHART

SIZE	BUSHING I.D.	DRIVEN SHAFT O.D.	BUSHING LENGTH	DRIVEN SHAFT KEYWAY	KIT TYPE	KIT#		
E17	0.625	5/8	1.50	3/16 X 3/32	S*	WKE850578		
	0.750	3/4		3/16 X 3/32	S*	WKE850579		
1.000 STANDARD BORE - NO BUSHING REQUIRED**								
E20	0.630*		1.75	*	C	WKE850483		
	0.750	3/4		3/16 X 3/32	K	WKE850638		
	0.875	7/8		3/16 X 3/32	K	WKE850659		
	1.000	1		1/4 X 1/8	K	WKE850468		
	1.125	1-1/8		1/4 X 1/8	S*	WKE850660		
	1.188	1-3/16		1/4 X 1/8	S*	WKE850625		
	1.250	1-1/4		1/4 X 1/8	S*	WKE850469		
1.438 STANDARD BORE - NO BUSHING REQUIRED**								
E24	0.750*		1.75	*	C	WKE850484		
	1.000	1		1/4 X 1/8	S*	WKE850653		
	1.125	1-1/8		1/4 X 1/8	S*	WKE850661		
	1.188	1-3/16		1/4 X 1/8	S*	WKE850662		
	1.250	1-1/4		1/4 X 1/8	S*	WKE850470		
	1.375	1-3/8		5/16 X 5/32	S*	WKE850663		
	1.438	1-7/16		3/8 X 3/16	S	WKE850471		
1.500 STANDARD BORE - NO BUSHING REQUIRED**								
E26	0.880*		1.75	*	C	WKE850485		
	1.000	1		1/4 X 1/8	K	WKE850627		
	1.125	1-1/8		1/4 X 1/8	K	WKE877792		
	1.188	1-3/16		1/4 X 1/8	S*	WKE850634		
	1.438	1-7/16		3/8 X 3/16	S	WKE850472		
	1.250	1-1/4		1/4 X 1/8	S*	WKE850479		
	1.375	1-3/8		5/16 X 5/32	S*	WKE850664		
	1.500	1-1/2		3/8 X 3/16	S	WKE850473		
	1.688 STANDARD BORE - NO BUSHING REQUIRED**							

SIZE	BUSHING I.D.	DRIVEN SHAFT O.D.	BUSHING LENGTH	DRIVEN SHAFT KEYWAY	KIT TYPE	KIT#
E30	1.000*		2.00	*	C	WKE850486
	1.250	1-1/4		1/4 X 1/8	K	WKE850481
	1.375	1-3/8		5/16 X 5/32	S*	WKE850665
	1.438	1-7/16		3/8 X 3/16	S	WKE850474
	1.500	1-1/2		3/8 X 3/16	S*	WKE850637
	1.688	1-11/16		3/8 X 3/16	S*	WKE850475
	1.750	1-3/4		3/8 X 3/16	S*	WKE850666
1.938 STANDARD BORE - NO BUSHING REQUIRED**						
E35	1.000*		2.19	*	C	WKE850487
	1.250	1-1/4		1/4 X 1/8	K	WKE850582
	1.438	1-7/16		3/8 X 3/16	S*	WKE850482
	1.500	1-1/2		3/8 X 3/16	S*	WKE850639
	1.750	1-3/4		3/8 X 3/16	S*	WKE850656
	1.938	1-15/16		1/2 X 1/4	S	WKE850476
2.000	2	1/2 X 1/4	S	WKE850477		
2.188 STANDARD BORE - NO BUSHING REQUIRED**						
E43	1.500*		2.75	*	C	WKE850562
	1.500	1-1/2		3/8 X 3/16	K	WKE850654
	1.750	1-3/4		3/8 X 3/16	S*	WKE850667
	1.875	1-7/8		1/2 X 1/4	S*	WKE850668
	1.938	1-15/16		1/2 X 1/4	S	WKE878017
	2.000	2		5/8 X 5/16	K	WKE850593
	2.188	2-3/16		1/2 X 1/4	S*	WKE850560
	2.250	2-1/4		1/2 X 1/4	S*	WKE850669
	2.438	2-7/16		5/8 X 5/16	S	WKE850561
	2.500	2-1/2		5/8 X 5/16	S	WKE878080
	2.750 STANDARD BORE - NO BUSHING REQUIRED**					

S* = Bushing uses a step key
 * Rough bore size, bushing to be customer bored and keyed
 ** Bore tolerances +.000 +.002

Multimount



Quill Input Shaft Bushing Kits



1 Piece Bushing

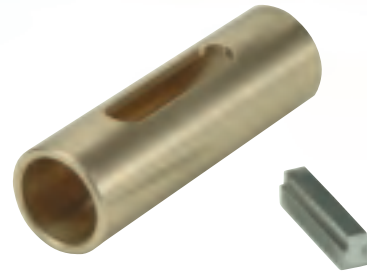

2 Piece Bushing

MOTOR FLANGE (SHAFT DIAMETER)	REDUCER INPUT ADAPTOR (BORE SIZE)	BUSHING LENGTH	KEYWAY SIZE	TYPE	KIT #
56C (0.625)	140TC (0.875)	1.44	3/16 X 3/32	1 PIECE	WK9810170
140TC (0.875)	180TC (1.125)	2.00	3/16 X 3/32	2 PIECE	WK9810174

Hollow Shaft Cover

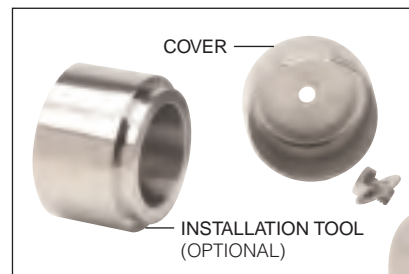
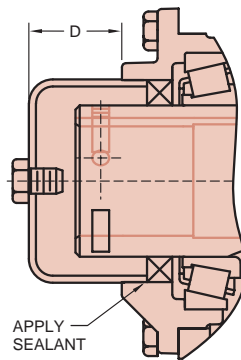
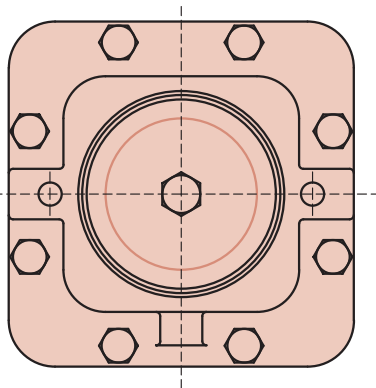

SE Encore shaft covers provide an economical method for protecting the rotating shaft and isolating the seal from outside contaminants. All shaft covers are made from corrosion resistant stainless steel and fit over either shaft end while allowing at least one half inch of clearance for a driven shaft keeper plate.

DIMENSIONS

SIZE	D
E17	1.31
E20	1.25
E24	1.31
E26	1.38
E30	1.56
E35	1.56
E43	1.25

Parts Included in Cover Kit:

- Cover
- Bolt and Washer
- Installation Instructions

KIT PART NUMBERS

SIZE	COVER	INSTALLATION TOOL *
E17	CKIT917	CTKIT917
E20	CKIT920	CTKIT920
E24	CKIT924	CTKIT924
E26	CKIT926	CTKIT926
E30	CKIT930	CTKIT930
E35	CKIT935	CTKIT935
E43	CKIT943	CTKIT943

*Optional—available separately



2D DRAWINGS & 3D MODELS
www.WINSMITH.com



Worm on Top Mounting Kits

**Worm on Top (T)
Quill Input Adaptor
Solid & Hollow Output Shafts
Base Mount**

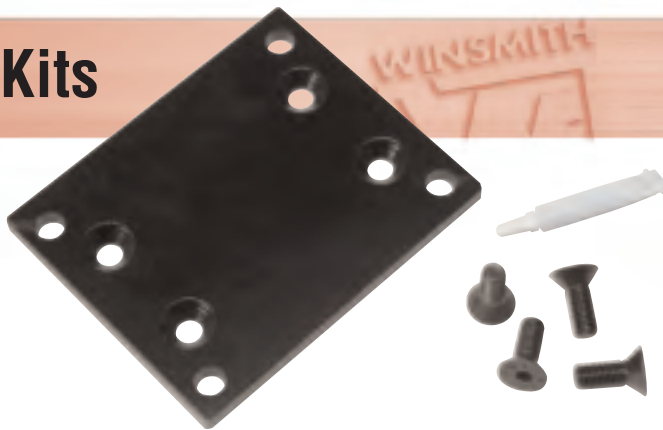

**MDNS Shown With Mounted (T) Base Kit
Solid Output Shaft**

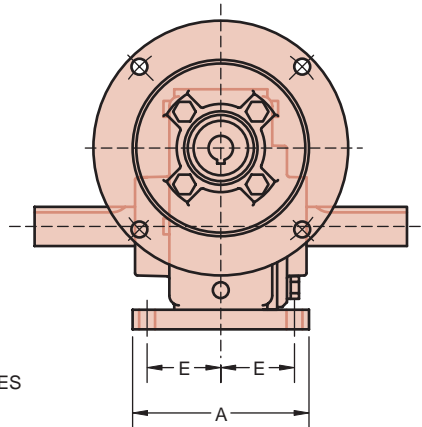
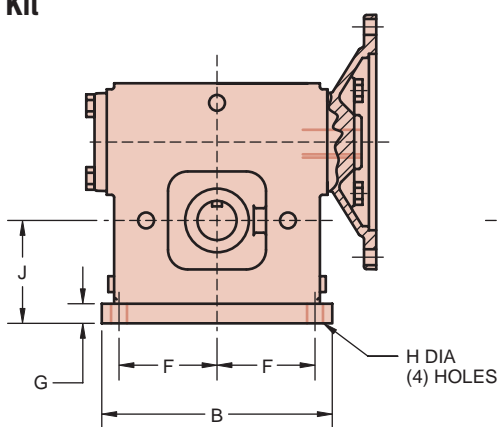
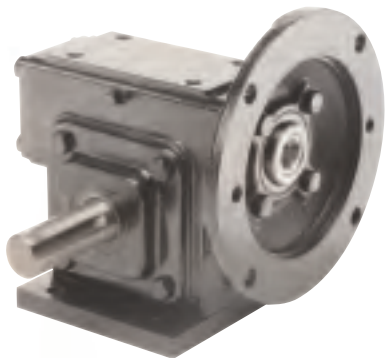

◆ Base Supplied Separately

**MDSS Shown With Mounted (T) Base Kit
Hollow Output Shaft**

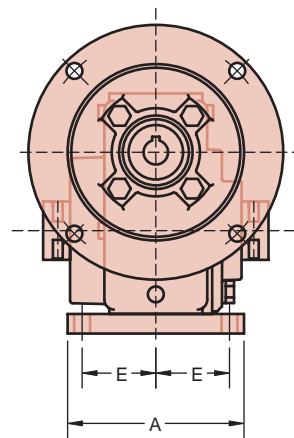
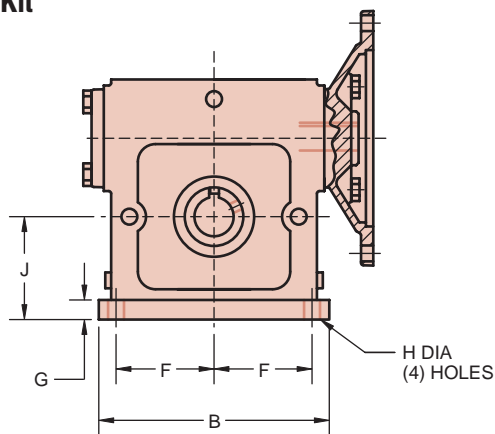
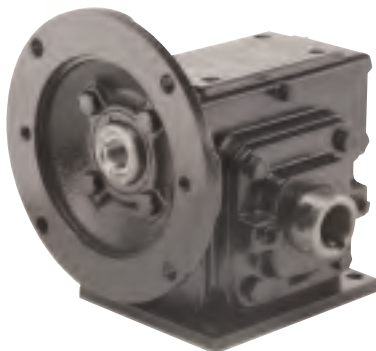

◆ Base Supplied Separately

SPEED REDUCER DIMENSIONS (in.)

Size	A	B	E	F	G	H	J	Kit #	Kit lb.*
E13*	4.00	5.00	1.63	2.13	.25	.281	2.00	BK9998005	2
E17	4.50	5.50	1.75	2.31	.31	.406	2.44	BK9998001	3
E20	4.50	5.88	1.88	2.50	.50	.406	2.63	BK9998008	4
E24	4.50	7.00	1.88	3.13	.38	.406	3.25	BK9998012	4
E26	4.50	7.50	1.88	3.25	.38	.406	3.50	BK9998016	4
E30	6.00	8.00	2.38	3.50	.50	.563	4.00	BK9998018	7
E35	6.50	10.00	2.63	4.13	.50	.563	4.50	BK9998034	10
E43	7.00	11.00	2.88	4.88	.63	.563	5.00	BK9998109	14

* Not available in MDSS hollow output ■ Approximate shipping weights



Worm on Bottom Mounting Kits

**Worm on Bottom (B)
Quill Input Adaptor
Solid & Hollow Output Shafts
Base Mount**



**MDNS Shown With Mounted (B) Base Kit
Solid Output Shaft**

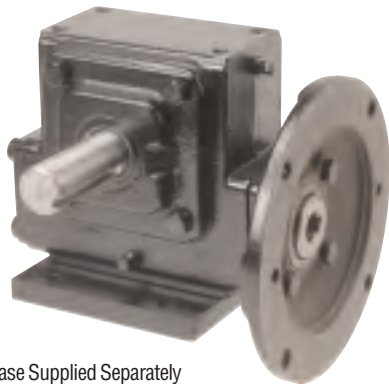

◆ Base Supplied Separately

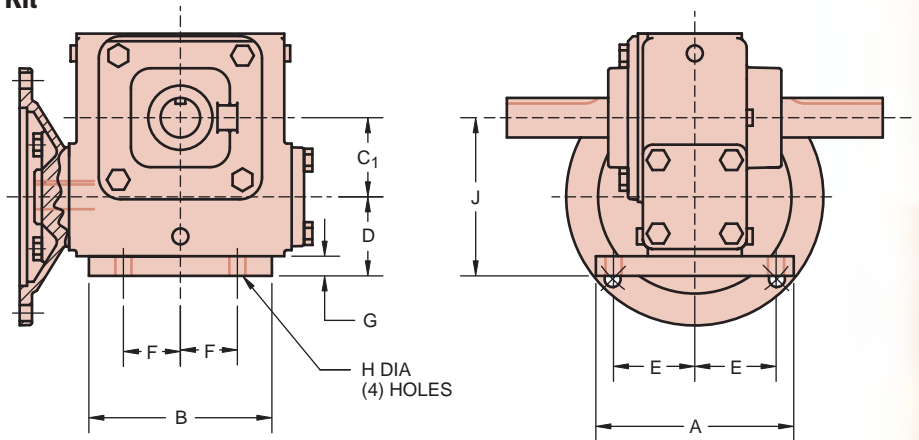

**MDSS Shown With Mounted (B) Base Kit
Hollow Output Shaft**

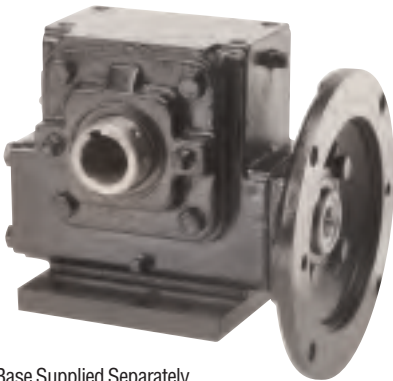

◆ Base Supplied Separately

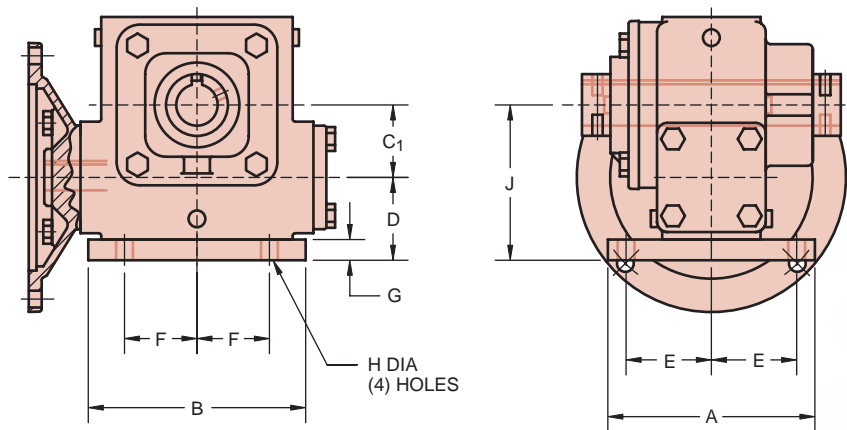

SPEED REDUCER DIMENSIONS (in.)

Size	A	B	C ₁	D	E	F	G	H	J	Kit #	Kit lb.*
E13*	3.50	5.00	1.333	1.63	1.38	2.13	.38	.281	2.96	BK9998004	2
E17	5.00	4.63	1.750	2.00	2.06	1.44	.50	.406	3.75	BK9998000	3
E20	5.00	4.63	2.000	2.00	2.06	1.44	.50	.406	4.00	BK9998000	3
E24	5.00	7.00	2.375	2.38	2.00	3.00	.38	.406	4.75	BK9998011	3
E26	4.75	7.00	2.625	2.50	2.00	3.00	.38	.406	5.13	BK9998015	3
E30	6.00	8.00	3.000	3.00	2.38	3.50	.50	.563	6.00	BK9998018	7
E35	6.50	10.00	3.500	3.13	2.63	4.13	.50	.563	6.63	BK9998034	10
E43	7.00	11.00	4.250	3.50	2.88	4.88	.63	.563	7.75	BK9998109	14

* Not available in MDSS hollow output. ■ Approximate shipping weights



2D DRAWINGS & 3D MODELS
www.WINSMITH.com



Vertical Input Mounting Kits

**Vertical (J)
Quill Input Adaptor
Solid & Hollow Output Shafts
Bracket Mount**



**MDNS Shown With Mounted (J) Bracket Kit
Solid Output Shaft**

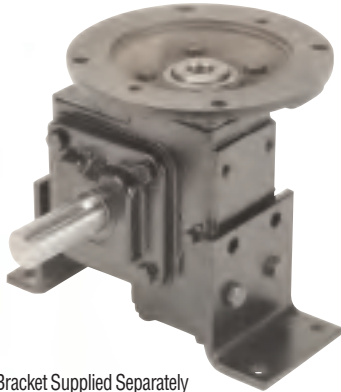

◆ Bracket Supplied Separately

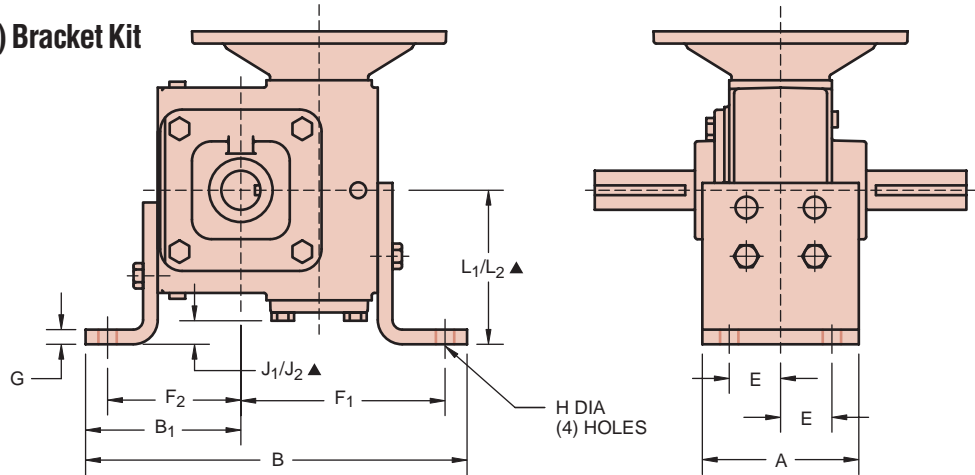

**MDSS Shown With Mounted (J) Bracket Kit
Hollow Output Shaft**

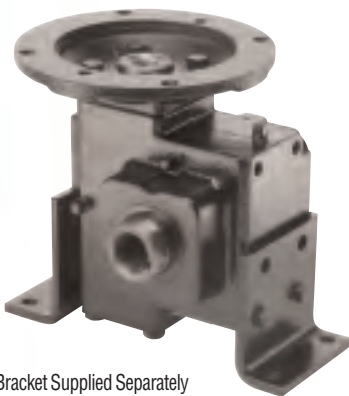

◆ Bracket Supplied Separately

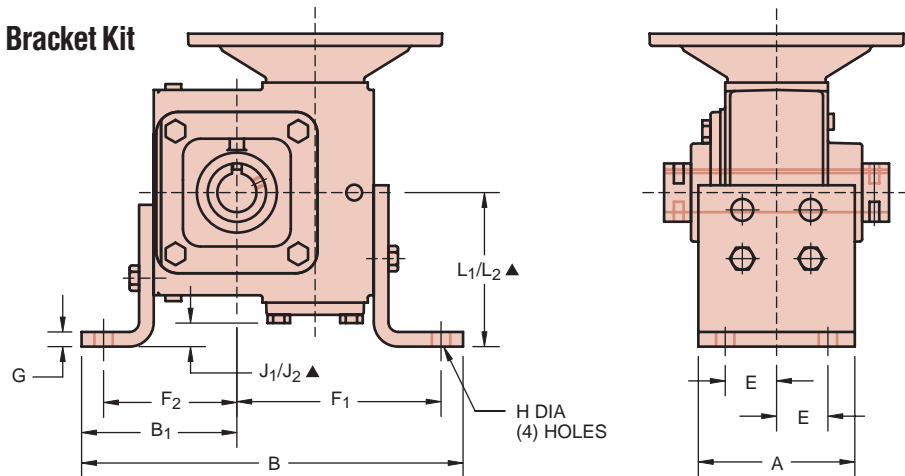

SPEED REDUCER DIMENSIONS (in.)

Size	A	B	B ₁	E	F ₁	F ₂	G	H DIA.	L ₁	J ₁	L ₂ [▲]	J ₂ [▲]	Kit #	Kit lb.*
E13*	3.00	7.43	3.10	1.00	3.82	2.60	.25	.344	2.94	.11	4.32	1.49	JK9998028	3
E17	3.50	8.63	3.50	1.25	4.63	3.00	.25	.406	3.50	.06	4.79	1.35	JK9998027	3
E20	4.00	9.75	3.97	1.31	5.22	3.41	.38	.469	3.94	.50	5.32	1.88	JK9998029	5
E24	4.00	10.75	4.63	1.44	5.56	4.06	.38	.469	4.63	.13	6.50	2.00	JK9998030	6
E26	4.50	11.63	4.75	1.56	6.25	4.13	.38	.531	4.75	.25	6.50	2.00	JK9998031	6
E30	5.50	12.50	5.25	2.00	6.63	4.63	.38	.531	4.75	.12	7.00	2.38	JK9998032	8
E35	5.50	14.50	6.19	2.00	7.56	5.19	.38	.531	5.69	.23	8.13	2.67	JK9998035	9
E43	6.50	15.88	6.56	2.50	8.56	5.81	.38	.656	6.50	.22	8.88	2.60	JK9998086	11

* Not available in MDSS hollow output ▲ L₂ and J₂ dimensions apply when using top (2) mounting holes on bracket



Flange Output Mounting Kits

Flange (U)
Quill Input Adaptor
Solid & Hollow Output Shafts
Bracket Mount



MDNS Shown With Mounted (U) Bracket Kit Solid Output Shaft

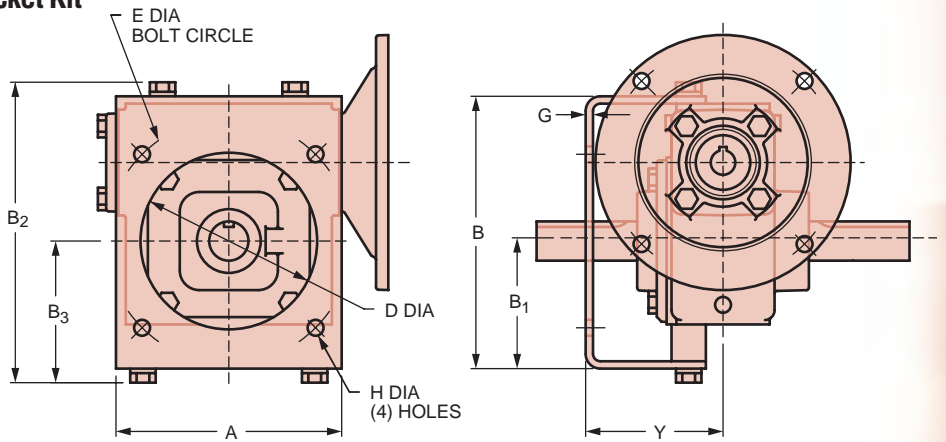
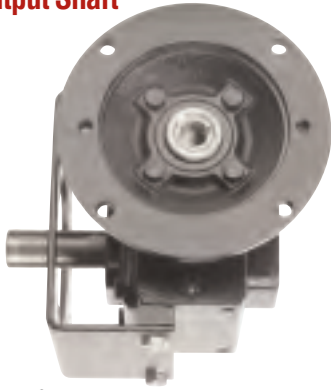

◆ Bracket Supplied Separately

MDSS Shown With Mounted (U) Bracket Kit Hollow Output Shaft

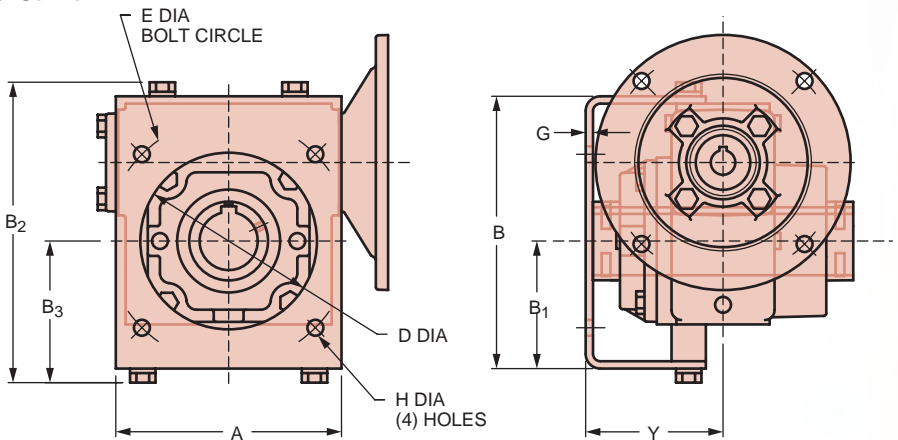
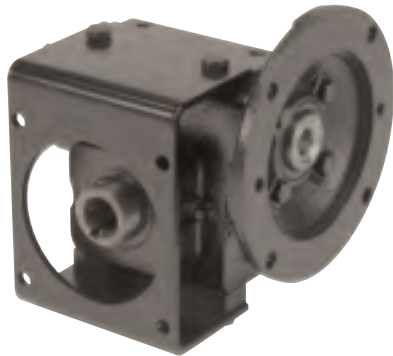

◆ Bracket Supplied Separately

SPEED REDUCER DIMENSIONS (in.)

Size	A	B	B ₁	B ₂	B ₃	D	E	G	H	Y	Kit #	Kit lb.*
E17	4.81	6.25	2.81	7.02	3.20	4.06	5.875	.19	.344	3.50	BK9998094	4
E20	5.75	6.94	3.25	7.71	3.64	4.50	6.500	.19	.406	3.50	BK9998095	4
E24	6.13	8.00	3.44	9.03	3.96	5.00	7.500	.19	.406	3.69	BK9998096	6
E26	7.19	8.63	3.63	9.66	4.14	6.00	8.000	.25	.406	3.82	BK9998097	7
E30	8.50	10.19	4.44	11.22	4.95	7.00	9.250	.25	.563	5.00	BK9998098	10
E35	8.50	11.00	4.63	12.27	5.26	7.00	10.000	.25	.563	5.06	BK9998099	11
E43	10.00	13.00	5.50	14.27	6.13	8.00	11.500	.38	.688	5.75	BK9998073	21

* Approximate shipping weights



2D DRAWINGS & 3D MODELS
 www.WINSMITH.com



Hanger Mounting Kits

Hanger (H)
Quill Input Adaptor
Solid & Hollow Output Shafts
Bracket Mount



MDNS Shown With Mounted (H) Bracket Kit Solid Output Shaft

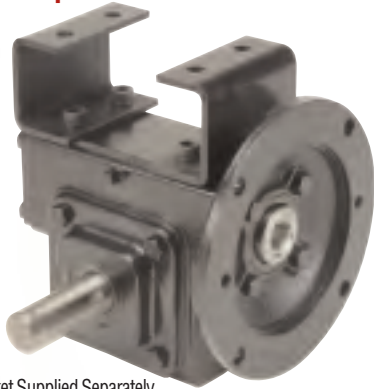

◆ Bracket Supplied Separately

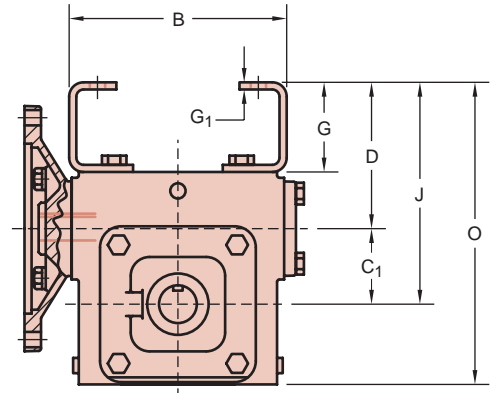
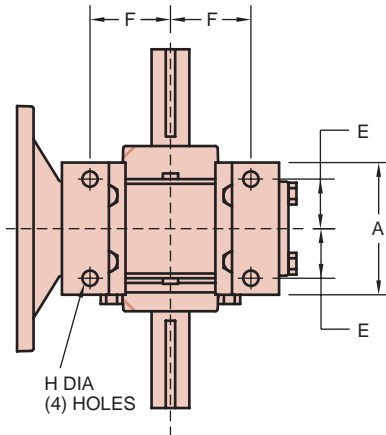

MDSS Shown With Mounted (H) Bracket Kit Hollow Output Shaft

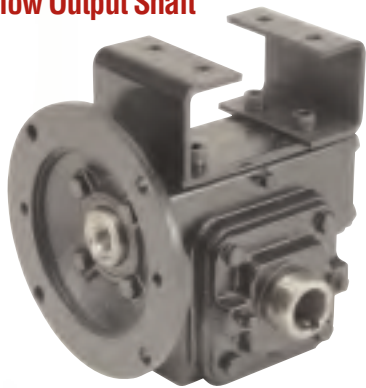

◆ Bracket Supplied Separately

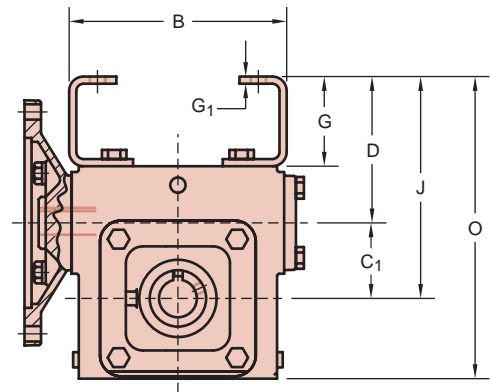
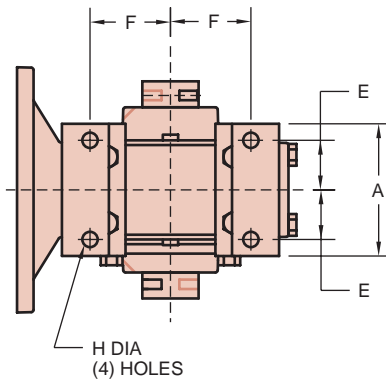

SPEED REDUCER DIMENSIONS (in.)

Size	A	B	C ₁	D	E	F	G	G ₁	H	J	O	Kit #	Kit lb.*
E17	3.38	5.75	1.750	3.88	.88	1.94	2.38	.19	.390	5.63	7.75	BK9998115	3
E20	3.50	5.88	2.000	3.88	.88	2.19	2.38	.19	.390	5.88	8.00	BK9998116	5
E24	4.13	7.75	2.375	4.50	1.13	2.19	2.50	.25	.515	6.88	9.75	BK9998117	6
E26	4.13	8.25	2.625	4.63	1.13	2.44	2.50	.25	.515	7.25	10.38	BK9998117	6
E30	5.50	8.88	3.000	5.50	2.19	3.31	3.00	.25	.531	8.50	12.00	BK9998124	8
E35	5.02	9.25	3.500	5.00	1.31	3.25	2.38	.31	.656	8.50	12.50	BK9998125	9

* Approximate shipping weights



Torque Arm Mounting Kits

Torque Arm (R)
 Quill Input Adaptor
 Hollow Output Shaft
 Bracket Mount

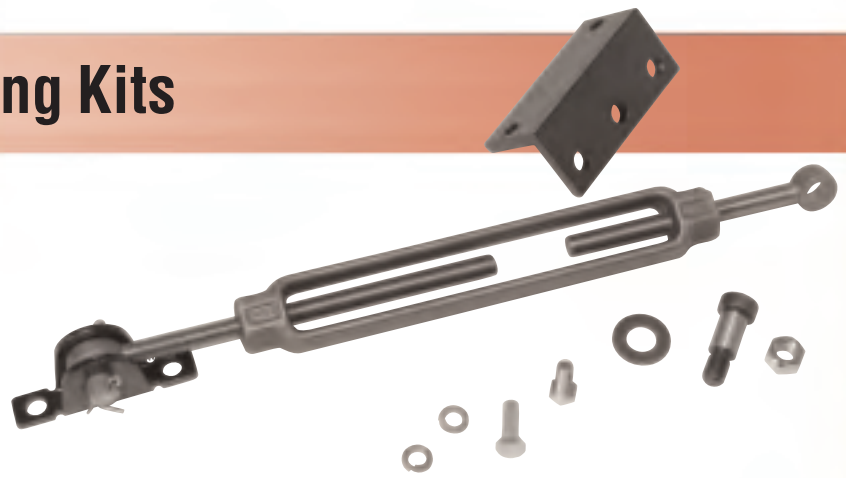

MDSS Shown With Mounted (R) Bracket Kit
 Hollow Output Shaft

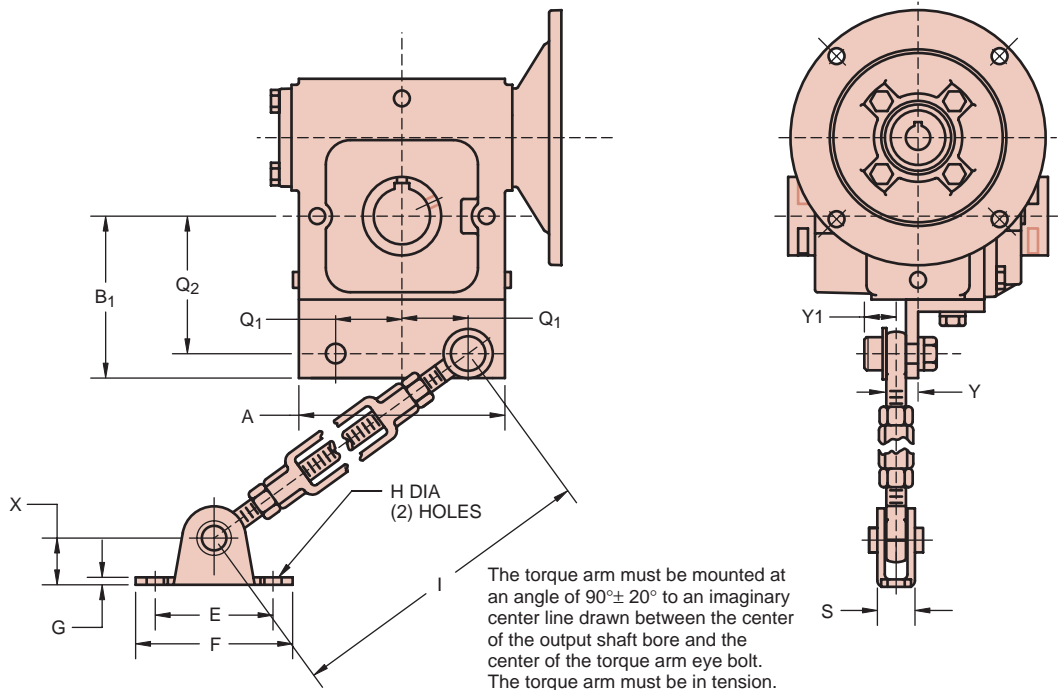

◆ Bracket Supplied Separately

SPEED REDUCER DIMENSIONS (in.)

Size	A	B ₁	E	F	G	H	I MIN	I MAX	Q ₁	Q ₂	S	Y	Y ₁	X	Kit#	Kit lb. [■]
E17	4.63	4.13	3.00	4.00	.19	.44	15.00	24.00	1.69	3.50	.75	.63	.81	1.19	TQ9952574	7
E20	5.25	4.13	3.00	4.00	.19	.44	15.00	24.00	1.69	3.50	.75	.63	.81	1.19	TQ9952442	7
E24	5.38	4.88	3.00	4.00	.19	.44	15.00	24.00	2.13	4.25	.75	.31	.81	1.19	TQ9952443	7
E26	5.88	5.13	3.00	4.00	.19	.44	15.00	24.00	2.31	4.50	.75	.44	.81	1.19	TQ9952444	7
E30	6.50	5.50	3.00	4.00	.19	.44	15.00	24.00	2.56	4.88	.75	.44	.81	1.19	TQ9952445	7
E35	7.75	6.50	3.50	4.75	.56	.53	21.00	29.00	3.00	5.63	2.13	.88	1.09	1.63	TQ9952446	13
E43	8.75	6.88	3.50	4.75	.56	.53	21.00	29.00	3.50	6.00	2.13	.56	1.09	1.63	TQ9952575	13

■ Approximate shipping weights

Multimount



2D DRAWINGS & 3D MODELS
 www.WINSMITH.com



Industry Interchange Base Plate

Interchange (C) Quill Input Adaptor Solid and Hollow Output Shafts Base Mount

The industry interchange base mount adapts the SE Encore series to the mounting of many other industrial speed reducers. Industry interchange base mounts are either flat (most E17 and all E24) or formed (E13, E17, E26 – E43). All Industry Interchange Base Mount Kits include attachment bolts.



MDNS SHOWN WITH INTERCHANGE (C) BASE MOUNT KIT SOLID OUTPUT SHAFT

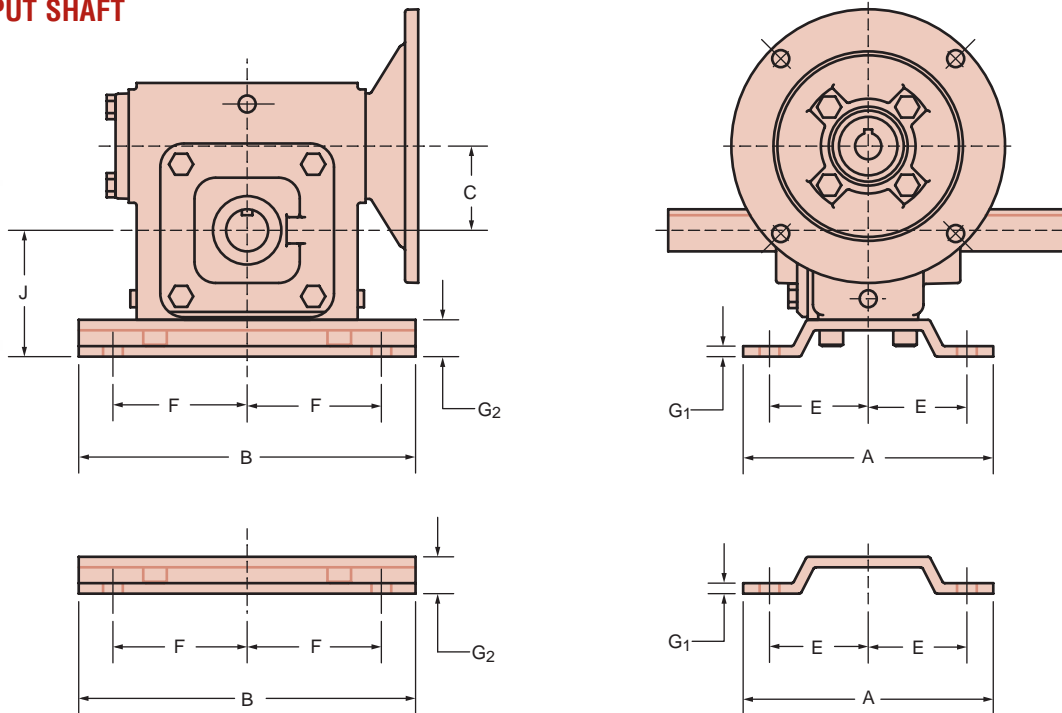

* Interchange Plate Supplied Separately

WINSMITH SIZE	WINSMITH CENTER DISTANCE	CENTER DISTANCE INTERCHANGE	OUTPUT SHAFT HEIGHT	BOLT MOUNTING PATTERN		BASE PLATE DIMENSIONS				BASE MOUNT KIT PART NUMBER
		C	J	E + E	F + F	A	B	G ₁	G ₂	
E13	1.333"	1.33"	2.25"	3.31"	4.38"	4.19"	5.50"	.25"	.50"	BK9998042
E17	1.750"	1.50"	2.50"	4.31"	5.25"	5.50"	6.44"	.375"	.375"	BK9998043
E17	1.750"	1.75"	2.75"	4.50"	5.75"	5.69"	7.00"	.25"	.625"	BK9998044
E20	2.000"	2.00"	3.00"	4.69"	6.38"	5.94"	8.00"	.313"	.875"	BK9998045
E20	2.000"	2.06"	3.00"	4.69"	6.38"	5.94"	8.00"	.313"	.875"	BK9998045
E24	2.375"	2.38"	3.25"	4.88"	7.06"	6.00"	8.50"	.375"	.375"	BK9998046
E26	2.625"	2.62"	3.69"	5.25"	8.00"	6.50"	9.63"	.25"	.562"	BK9998047
E30	3.000"	3.25"	4.38"	6.13"	9.50"	7.50"	11.19"	.375"	.875"	BK9998048
E30	3.000"	3.50"	4.38"	6.13"	9.50"	7.50"	11.19"	.375"	.875"	BK9998048
E35	3.500"	3.75"	4.81"	7.00"	10.38"	9.00"	12.00"	.375"	.813"	BK9998049



Worm Gear Ratio Multiplier

The Worm Gear Ratio Multiplier features a quill input adaptor along with a machined register output flange and shaft that duplicate NEMA C face flange/shaft dimensions. The following combinations are available:

- Sizes E13 and E17 are available with NEMA 56C output flange/shaft dimensions and NEMA 56C or 140TC input adaptor dimensions.*
- Sizes E17, E20, E24, and E26 are available with NEMA 140TC output flange/shaft dimensions and NEMA 56C, 140TC, or 180TC input adaptor dimensions.*
- Register diameter is machined to a NEMA tolerance of 0.003 inches, providing a precision interface with the driven equipment, which can be very useful especially in motion control applications.

- Available in 5, 10, 15, 20, 25, 30, 40, 50, and 60 ratios and configurable as either a left (L) or a right (R) assembly.
- Completely self-contained ratio multiplier and includes an open-close vent, Mobil Glygoyle 460 lubricant, and the WinGuard Epoxy Coating System.

Coupling the Worm Gear Ratio Multiplier to the input of another NEMA C face reducer provides additional reduction. It also offers an easy method of creating a double reduction reducer on location or when mounting to another piece of NEMA C face equipment such as a brake or a clutch. Various assemblies can be created by mounting it in any one of four positions.

MULTIMOUNT WORM GEAR RATIO MULTIPLIER NOMENCLATURE OVERVIEW

SIZE (Center Distance)	MODEL	RATIO	ASSEMBLY DESIGNATION	QUILL INPUT ADAPTOR	OUTPUT FLANGE
E13 – 1.333"	MDDS	5	Solid Output Shaft R - Right L - Left	56C	56C
E17 – 1.750"		10		140TC	140TC
E20 – 2.000"		15		180TC	180TC
E24 – 2.375"		20			
E26 – 2.625"		25			
		30			
		40			
	50				
	60				

* For 42C and 48C input adaptor, please contact Winsmith.



Selection By Input Horsepower

REDUCER SIZE AND TORQUE (lbf·in.) AT 1750 RPM INPUT ²

1.00 SERVICE FACTOR

OUTPUT RPM	RATIO ¹	HP	INPUT HORSEPOWER								
			0.25	0.33	0.50	0.75	1.00	1.50	2.00	3.00	5.00
350	5	SIZE			E13	E13	E13	E17	E17	E20	E24
		TORQUE			128	128	171	258	343	518	863
175	10	SIZE		E13	E13	E13	E17	E17	E20	E24	
		TORQUE		109	165	248	338	507	687	1021	
117	15	SIZE		E13	E13	E17	E17	E20	E24	E26	
		TORQUE		157	238	370	494	749	1003	1512	
88	20	SIZE	E13	E13	E17	E17	E20	E24	E24		
		TORQUE	153	202	321	483	650	983	1311		
70	25	SIZE	E13	E13	E17	E20	E20	E24	E26		
		TORQUE	185	245	391	596	795	1197	1620		
58	30	SIZE	E13	E13	E17	E20	E24	E26			
		TORQUE	209	276	452	687	938	1427			
44	40	SIZE	E13	E17	E17	E24	E24				
		TORQUE	256	383	580	902	1203				
35	50	SIZE	E17	E17	E20	E24	E26				
		TORQUE	340	449	706	1083	1481				
29	60	SIZE	E17	E20	E24	E26					
		TORQUE	386	525	810	1268					

REDUCER SIZE AND TORQUE (lbf·in.) AT 1750 RPM INPUT ²

1.25 SERVICE FACTOR

OUTPUT RPM	RATIO ¹	HP	INPUT HORSEPOWER								
			0.25	0.33	0.50	0.75	1.00	1.50	2.00	3.00	5.00
350	5	SIZE			E13	E13	E13	E17	E17	E20	E26
		TORQUE			128	128	171	258	343	518	866
175	10	SIZE		E13	E13	E17	E17	E20	E24	E26	
		TORQUE		109	165	253	338	515	680	1026	
117	15	SIZE		E13	E13	E17	E20	E24	E24		
		TORQUE		157	238	370	500	751	1003		
88	20	SIZE	E13	E13	E17	E17	E20	E24	E26		
		TORQUE	153	202	321	483	650	983	1322		
70	25	SIZE	E13	E13	E17	E20	E24	E26			
		TORQUE	185	243	391	596	798	1215			
58	30	SIZE	E13	E17	E17	E24	E24				
		TORQUE	209	298	452	703	938				
44	40	SIZE	E17	E17	E20	E24	E26				
		TORQUE	290	383	585	902	1223				
35	50	SIZE	E17	E17	E24	E24					
		TORQUE	340	449	722	1083					
29	60	SIZE	E20	E20	E24	E26					
		TORQUE	400	525	810	1268					

1. Exact ratio

2. If input speed is below 1160 RPM, please specify speed and mounting position to ensure proper lubrication.

MDDS Model Worm Gear Ratio Multiplier

Quill Input Adaptor
Solid Output Shaft
Flange Mount – NEMA

4.50 inch diameter register *



Assembly R shown, Assembly L available

DIMENSIONS

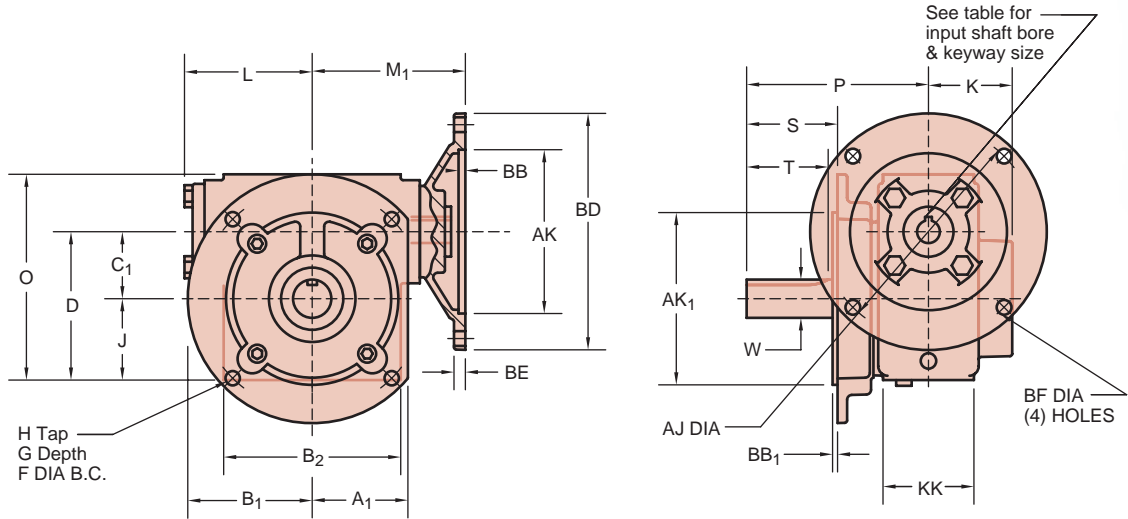

RATIO MULTIPLIER DIMENSIONS (in.)

Size	Output Frame	A ₁	AK ₁ **	B ₁	B ₂	BB ₁	C ₁	D	F DIA.	G DEPTH	H TAP	J	K	KK	L	M ₁	O	P	W*	S	T	KEYWAY	lb.*
E13	56C	2.38	4.50	3.25	3.88	.13	1.333	3.08	5.88	.75	3/8-16	1.75	1.94	2.00	2.83	3.63	4.33	4.56	.625	2.06	1.81	3/16 X 3/32	21
E17	56C	2.50	4.50	3.25	4.63	.13	1.750	3.88	5.88	.88	3/8-16	2.13	2.19	2.38	3.44	4.06	5.38	4.44	.625*	2.06	1.81	3/16 X 3/32	23
E17	140TC	2.50	4.50	3.25	4.63	.13	1.750	3.88	5.88	.88	3/8-16	2.13	2.19	2.38	3.44	4.06	5.38	4.50	.875	2.13	2.00	3/16 X 3/32	23
E20	140TC	2.50	4.50	3.25	5.25	.13	2.000	4.13	5.88	.88	3/8-16	2.13	2.19	2.38	3.44	4.06	5.63	4.75	.875	2.13	2.00	3/16 X 3/32	29
E24	140TC	3.25	4.50	3.25	5.38	.13	2.375	5.25	5.88	.75	3/8-16	2.88	2.69	3.13	4.50	5.38	7.25	5.50	.875	2.13	2.25	3/16 X 3/32	48
E26	140TC	3.25	4.50	3.25	5.88	.13	2.625	5.75	5.88	.75	3/8-16	3.13	2.69	3.13	4.50	5.38	7.88	5.50	.875*	2.13	2.25	3/16 X 3/32	52

* Shaft diameter tolerances +.000-.001 Dimensions shown are for construction purposes only. Please contact Winsmith for certified dimension sheets.

‡ Approximate shipping weights ** Register diameter tolerances +.000-.003

• Catalog output torque limited to 575 lbf-in. • Catalog output torque limited to 1578 lbf-in.

INPUT ADAPTOR DIMENSIONS (in.)

INPUT ADAPT. DIM.	56C	140TC	180TC
AJ	5.88	5.88	7.25
AK	4.50	4.50	8.50
BB	.19	.19	.19
BD	6.50	6.50	9.00
BD ₁	6.63	6.63	9.00
BE	.31	.31	.38
BF	.406	.406	.531
KEYWAY	3/16 X 3/32		1/4 X 1/8
BORE ^{+0.001} / _{-.000}	.6255	.8755	1.1255

* See pages 140-141 for an 8.500 inch diameter register of the Worm Gear Ratio Multiplier.



2D DRAWINGS & 3D MODELS
www.WINSMITH.com



Helical Gear Ratio Multiplier

The Helical Gear Ratio Multiplier features a quill input flange along with a machined register output flange and shaft that duplicate NEMA C face flange and shaft dimensions. The following combinations are available:

- Size 206 is available with a NEMA 140TC input flange and a 4.500 inch, registered (140TC) output flange and shaft.
- Size 320 is available with a NEMA 180TC input flange and an 8.500 inch (180TC) output flange and shaft.
- Register diameter is machined to a NEMA tolerance of 0.003 inches, providing a precision interface with the driven equipment, which can be very useful especially in motion control applications.
- Available with 5.07 and 6.08 ratios.
- Completely self-contained ratio multiplier and includes an open-close vent, Mobilgear 600 XP 220 Oil and the WinGuard Epoxy Coating System.

Coupling the Helical Gear Ratio Multiplier to the input of another NEMA C face reducer provides additional reduction. It also offers an easy method of creating a double reduction reducer on location or when mounting to another piece of NEMA C face equipment such as a brake or a clutch.



MHDS Model Helical Gear Ratio Multiplier

Quill Input Flange Solid Output Shaft Flange Mount – NEMA

4.50 inch diameter register *

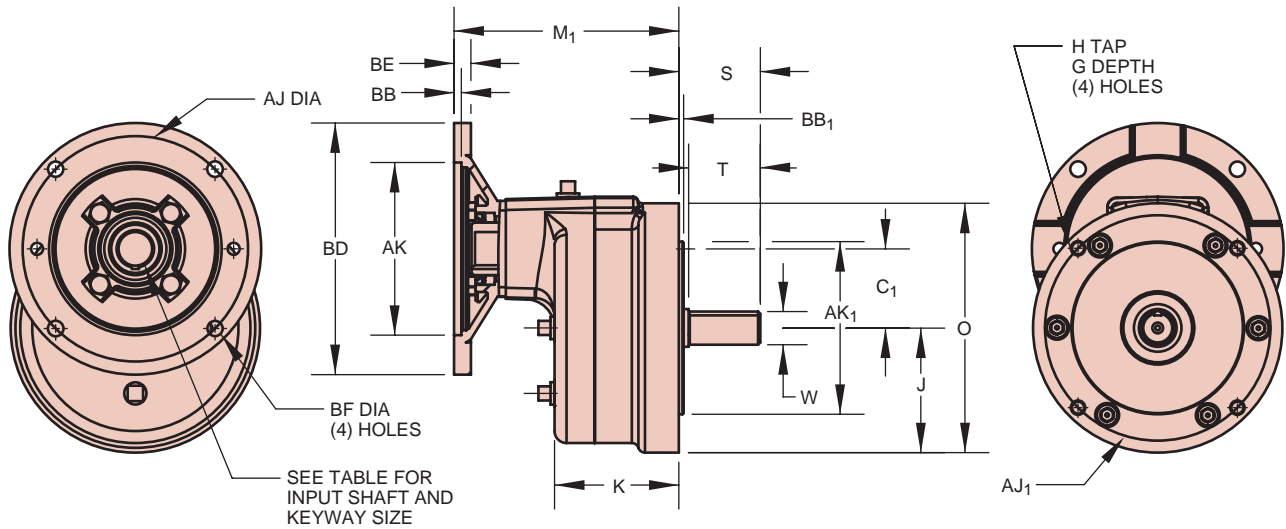
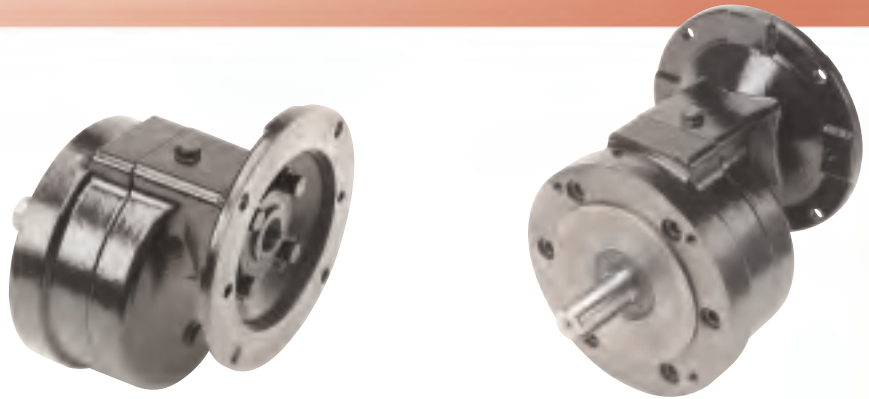

RATIO MULTIPLIER DIMENSIONS (in.)

Size	C ₁	H	G DEPTH	J	K	M ₁ 56C 140TC	M ₁ 180TC	O	OUTPUT ADAPTOR							
									W*	S	T	KEYWAY	AJ ₁	AK ₁	B ₁	lb.*
206	2.062	3/8-16	.75	3.25	3.25	5.75	NA	6.50	.875	2.13	1.88	3/16 X 3/32	5.875	4.50	.125	25
320	3.200	1/2-13	1.00	4.50	4.35	7.13	7.31	9.00	1.125	2.88	2.50	1/4 X 1/8	7.250	8.50	.250	48

* Shaft diameter tolerances +.000 -.001

▪ Approximate shipping weights

RATIO MULTIPLIER RATINGS

RATIO (NOMINAL)	INPUT RPM	CENTER DISTANCE			
		2.06		3.20	
		INPUT HP	OUTPUT TORQUE	INPUT HP	OUTPUT TORQUE
5	1750	3.22	579	11.59	2082
	1160	2.21	601	8.06	2182
6	1750	2.67	575	9.47	1991
	1160	1.83	597	6.57	2085

INPUT FLANGE DIMENSIONS (in.)

INPUT FLANGE DIM.	56C	140TC	180TC
AJ	5.88	5.88	7.25
AK	4.50	4.50	8.50
BB	.19	.19	.19
BD	6.50	6.50	9.00
BE	.31	.31	.56
BF	.406	.406	.531
KEYWAY	3/16 X 3/32		1/4 X 1/8
BORE ^{+.001} / _{-.000}	.6255	.8755	1.1255



2D DRAWINGS & 3D MODELS
www.WINSMITH.com



SE Encore – Integral Worm Gear Speed Reducers

AVAILABLE IN 1 DAY TO 4 WEEKS*

- WinGuard™ Black or White Epoxy Coating System
- Quill or Coupling Input Adaptor or Solid Input Shaft
- Solid Output Shafts
- Hollow Output Shafts
(Bored to Size or with Bushings)
- Base Attached
- Double Reduction Worm
or Helical Primary

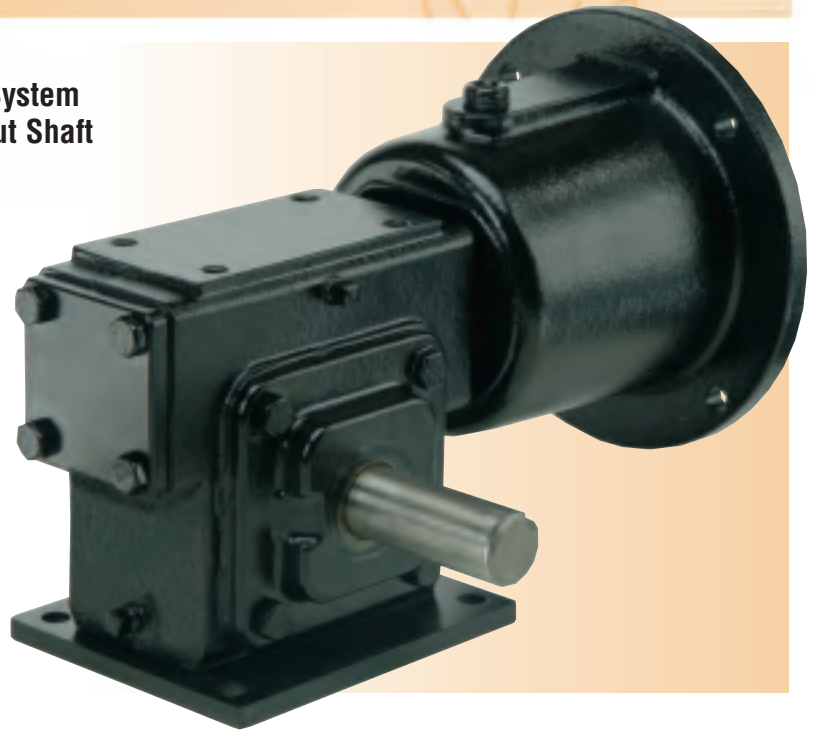

SE Encore Integral Worm Gear Speed Reducers Table of Contents

Single Reduction Models Quick Select	32
Single Reduction Models Information	36
Helical/Worm Double Reduction Models Quick Select	68
Helical/Worm Double Reduction Models Information	72
Worm/Worm Double Reduction Models Quick Select	86
Worm/Worm Double Reduction Models Information	90
Accessories	104
Hollow Output Shaft Bushings	104
Quill Input Bushings	105
Hollow Shaft Covers	105
Flexible Couplings	106
Coupled Input Adaptors	106
Input Cap and Output Cover Bolt Patterns	107
Lubricant Levels for Special Mounting Positions	108

SE ENCORE – INTEGRAL

SE Encore Integral worm gear speed reducers are assembled to customer application specifications and ready to use out of the box.** SE Encore Integral worm gear speed reducers are available in a variety of reduction combinations, options, and input adaptor configurations. The lubricant in an SE Encore Integral product is filled to a level determined by the unit's intended mounting position for optimal performance. Additionally, SE Encore Integral worm gear speed reducers can operate as sealed units in applications involving intermittent use. They are also supplied with an easy optional open-close vent kit for heavy or continuous duty applications.*** All SE Encore Integral speed reducers are available from Winsmith within one day to four weeks, depending upon configuration.*



* Typical availability.
 ** Winsmith will mount customer supplied motors.
 *** See "Appendix" section of this catalog for more details.

SE Encore – Integral Worm Gear Speed Reducers

INTEGRAL CONFIGURATION PROCEDURE

SIZE

Identify the three digit nomenclature for size appearing in the selection pages of this catalog section.

Example: 1HP input, 30:1 gear reduction, 1750 RPM 1.25 service factor yields a 2.375" center distance speed reducer. The nomenclature for the size of this unit is "E24."

MODEL

There are a wide variety of models available in the Integral product offering. Each is identified at the top of the corresponding dimension page in this section by a complete description and by the four letter (e.g. MDNS) model nomenclature.

MODEL NOMENCLATURE	DESCRIPTION
XDVS	Solid input shaft; flanged, vertical mount solid output shaft
CSFD	Coupled input shaft; flange mount, hollow output shaft, double reduction

RATIO

Identify the required ratio of the gear reducer in full format (i.e. 30:1), or in brief format (i.e. 30).

SINGLE REDUCTION RATIO'S	DOUBLE REDUCTION RATIO'S	
5	25	300
7.5	30	360
10	38	500
15	50	750
20	60	1000
25	75	1500
30	90	2000
40	100	3000
50	120	3600
60	150	4000
80	180	5000
100	200	6000
	250	8000
		10000

INTEGRAL PRODUCT NOMENCLATURE EXAMPLES

SIZE	MODEL	RATIO	ASSEMBLY	ADAPTOR SIZE	BORE SIZE	ACCESSORY And MOUNTING	COMPLETE NOMENCLATURE
E17	CSFS	50	L	56C		Coupling L 075 100046	E17 CSFS 50 L 56C with Coupling L 075 100046
E24	MDSD	60	DLR	56C	1.000"	WKE850653	E24 MDSD 60 DLR 56C 1.000" Output Bushing for 1.500" Output Bore
E26	MDTD	500	LULR	140TC			E26 MDTD 500 LULR 140TC Worm/Worm Double Reduction
E30	MDSS	5	DLR	180TC	1.938"	Inverted Mount	E30 MDSS 5 DLR 180TC 1.938 Inverted Mount
E35	XDSD	300	DLR	140TC	1.938"		E35 XDSD 300:1 DLR 1.938 Helical/Worm Double Reduction

ASSEMBLY

The assembly of an Integral product is described by the relative positions of the input and output shaft. Refer to the dimension pages in this catalog section for the assembly possibilities associated with each speed reducer model. **Example:** The nomenclature for a size E20 reducer of model XDNS and assembled with two standard output shaft extensions is stated as "E20 XDNS LR." **Example:** The nomenclature of a size E43 reducer of model CSFS with output flange to the right of the input is stated as "E43 CSFS DLR."

INPUT ADAPTOR

Identify the input adaptor for the motor flange being mounted to the Integral product. The dimension pages in this section contain the possible input adaptor selections for each speed reducer size. If an input bushing is desired, specify the desired adaptor size assembled with bushing. These bushings will be factory installed prior to shipment. **Example:** The nomenclature for a NEMA 56C adaptor flange is "56C."

HOLLOW OUTPUT SHAFT BORE SIZE

Identify the hollow output shaft bore size of an MDSS using the tables on page 52. Express the bore size as a decimal (Example = 1.438"). Specify a standard bore unit, the desired hollow output bore size, and the output shaft bushing kit part number if an output bore bushing kit is required. **Example:** To include an output bushing kit on an E20 CDSS that creates a 0.750" output bore, chose kit number WKE850638 or specify, "Bush output to 0.750" bore."

ACCESSORIES

Identify the required Integral product accessory either by "kit" part number or by description. All accessories in this section of the catalog, except output bushing kits, are factory mounted prior to shipment. **Example:** To include an output bushing kit on an E20 CDNS that creates a 0.750" output bore, chose kit number WKE850638 or specify, "Bush output to 0.750" bore."

SPECIAL MOUNTINGS AND LUBRICANT LEVEL

Identify the proper lubricant level for the desired mounting position from the table on pages 108-109. The choices are *Standard*, *Inverted*, *Input shaft horizontal*, or *Input shaft vertical*.



2D DRAWINGS & 3D MODELS
www.WINSMITH.com



Single Reduction Models Quick Select

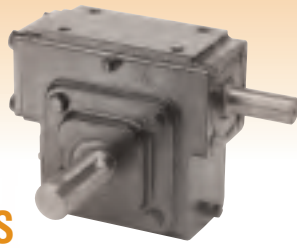

XDNS

Universal
Solid Input Shaft
Solid Output Shaft
Housing Mount

See Page 36

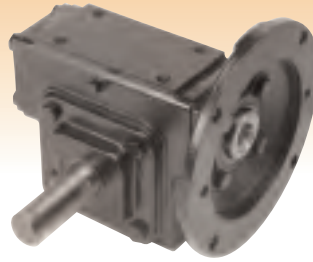

MDNS

Universal
Quill Input Adaptor
Solid Output Shaft
Housing Mount

See Page 37



CDNS

Universal
Coupled Input Adaptor*
Solid Output Shaft
Housing Mount

See Page 37

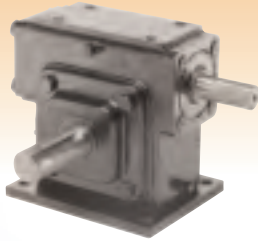

XDTS

Worm-On-Top
Solid Input Shaft
Solid Output Shaft
Base Mount

See Page 38

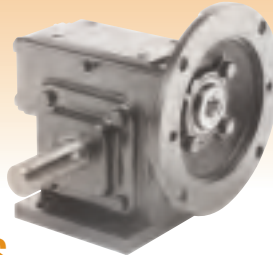

MDTS

Worm-On-Top
Quill Input Adaptor
Solid Output Shaft
Base Mount

See Page 39

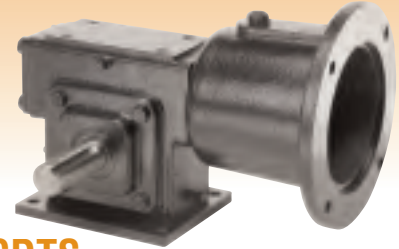

CDTS

Worm-On-Top
Coupled Input Adaptor*
Solid Output Shaft
Base Mount

See Page 39

Depending on size and base selection, the coupled input adaptor may interfere with the mounting base. Please contact Winsmith for assistance.



XDDBS

Worm-On-Bottom
Solid Input Shaft
Solid Output Shaft
Base Mount

See Page 40

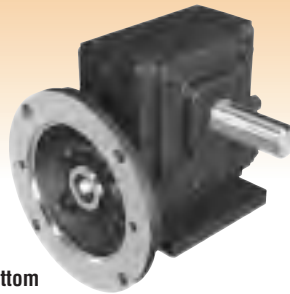

MDDBS

Worm-On-Bottom
Quill Input Adaptor
Solid Output Shaft
Base Mount

See Page 41



CDDBS

Worm-On-Bottom
Coupled Input Adaptor*
Solid Output Shaft
Base Mount

See Page 41

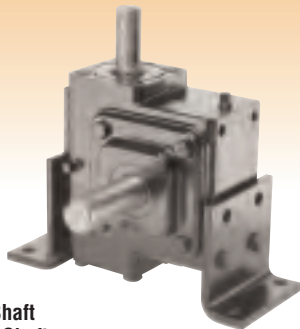

XDJS

"J" Vertical
Solid Input Shaft
Solid Output Shaft
Bracket Mount

See Page 42



MDJS

"J" Vertical
Quill Input Adaptor
Solid Output Shaft
Bracket Mount

See Page 43



CDJS

"J" Vertical
Coupled Input Adaptor*
Solid Output Shaft
Bracket Mount

See Page 43

Single Reduction Models Quick Select

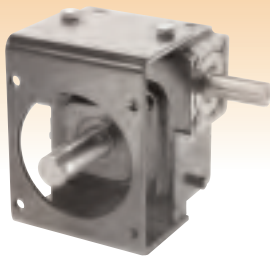

XDUS
 "U" Flange
 Solid Input Shaft
 Solid Output Shaft
 Bracket Mount
 See Page 44

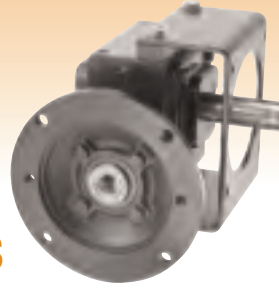

MDUS
 "U" Flange
 Quill Input Adaptor
 Solid Output Shaft
 Bracket Mount
 See Page 45



CDUS
 "U" Flange
 Coupled Input Adaptor
 Solid Output Shaft
 Bracket Mount
 See Page 45

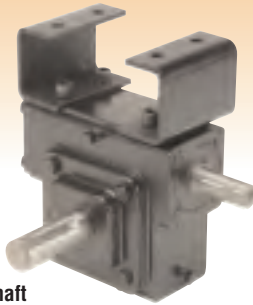

XDHS
 Hanger
 Solid Input Shaft
 Solid Output Shaft
 Bracket Mount
 See Page 46

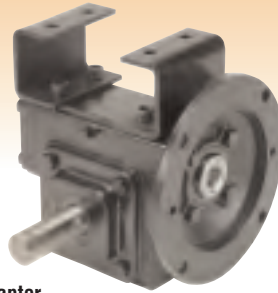

MDHS
 Hanger
 Quill Input Adaptor
 Solid Output Shaft
 Bracket Mount
 See Page 47

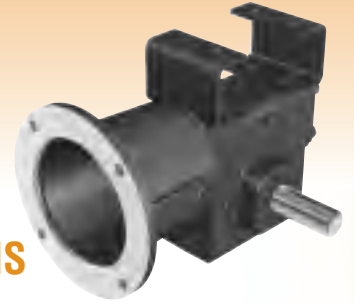

CDHS
 Hanger
 Coupled Input Adaptor
 Solid Output Shaft
 Bracket Mount
 See Page 47

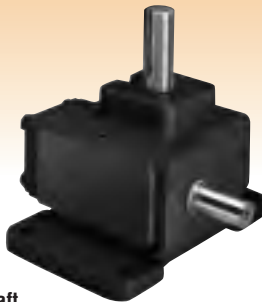

XDVS
 Vertical
 Solid Input Shaft
 Solid Output Shaft
 Flange Mount
 See Page 48

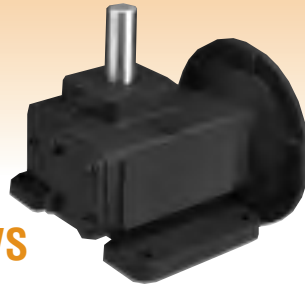

MDVS
 Vertical
 Quill Input Adaptor
 Solid Output Shaft
 Flange Mount
 See Page 49

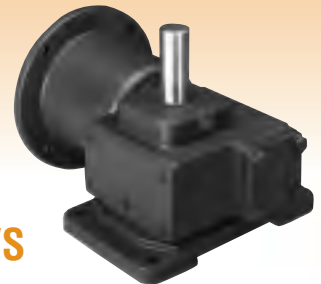

CDVS
 Vertical
 Coupled Input Adaptor
 Solid Output Shaft
 Flange Mount
 See Page 49



XDLS
 Drop Bearing
 Solid Input Shaft
 Solid Output Shaft
 Flange Mount
 See Page 50

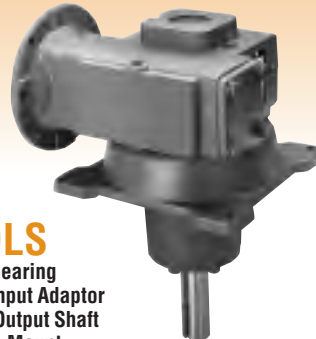

MDLS
 Drop Bearing
 Quill Input Adaptor
 Solid Output Shaft
 Flange Mount
 See Page 51



CDLS
 Drop Bearing
 Coupled Input Adaptor
 Solid Output Shaft
 Flange Mount
 See Page 51



Single Reduction Models Quick Select

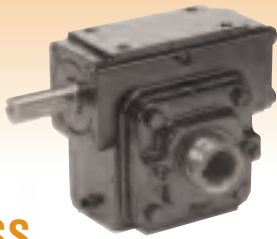

XDSS
 Universal
 Solid Input Shaft
 Hollow Output Shaft
 Housing Mount
 See Page 52



MDSS
 Universal
 Quill Input Adaptor
 Hollow Output Shaft
 Housing Mount
 See Page 53

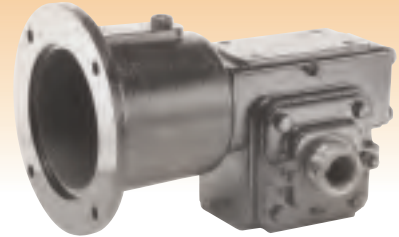

CDSS
 Universal
 Coupled Input Adaptor
 Hollow Output Shaft
 Housing Mount
 See Page 53

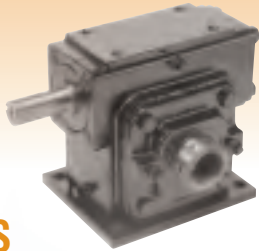

XSTS
 Worm-On-Top
 Solid Input Shaft
 Hollow Output Shaft
 Base Mount
 See Page 54

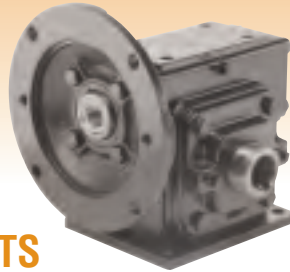

MSTS
 Worm-On-Top
 Quill Input Adaptor
 Hollow Output Shaft
 Base Mount
 See Page 55



CSTS
 Worm-On-Top
 Coupled Input Adaptor
 Hollow Output Shaft
 Base Mount
 See Page 55

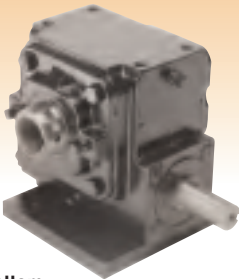

XSBS
 Worm-On-Bottom
 Solid Input Shaft
 Hollow Output Shaft
 Base Mount
 See Page 56



MSBS
 Worm-On-Bottom
 Quill Input Adaptor
 Hollow Output Shaft
 Base Mount
 See Page 57



CSBS
 Worm-On-Bottom
 Coupled Input Adaptor
 Hollow Output Shaft
 Base Mount
 See Page 57

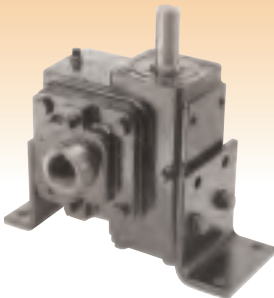

XSJS
 "J" Vertical
 Solid Input Shaft
 Hollow Output Shaft
 Bracket Mount
 See Page 58

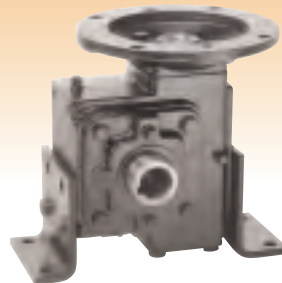

MSJS
 "J" Vertical
 Quill Input Adaptor
 Hollow Output Shaft
 Bracket Mount
 See Page 59

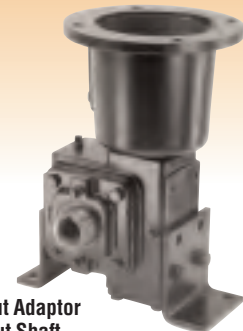

CSJS
 "J" Vertical
 Coupled Input Adaptor
 Hollow Output Shaft
 Bracket Mount
 See Page 59

Integral

Single Reduction Models Quick Select

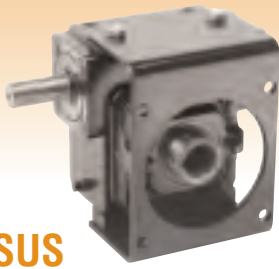

XSUS

"U" Flange
Solid Input Shaft
Hollow Output Shaft
Bracket Mount

See Page 60

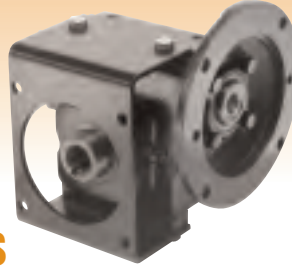

MSUS

"U" Flange
Quill Input Adaptor
Hollow Output Shaft
Bracket Mount

See Page 61



CSUS

"U" Flange
Coupled Input Adaptor
Hollow Output Shaft
Bracket Mount

See Page 61

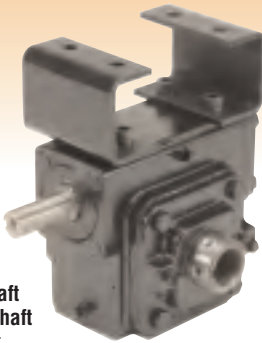

XSHS

Hanger
Solid Input Shaft
Solid Output Shaft
Bracket Mount

See Page 62

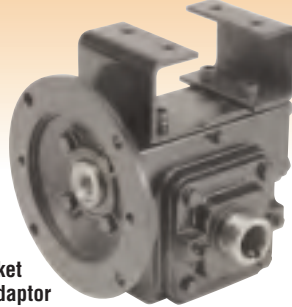

MSHS

Hanger Bracket
Quill Input Adaptor
Solid Output Shaft
Bracket Mount

See Page 63



CSHS

Hanger
Coupled Input Adaptor
Solid Output Shaft
Bracket Mount

See Page 63

XSRS

Torque Arm
Solid Input Shaft
Hollow Output Shaft
Bracket Mount

See Page 64



MSRS

Torque Arm
Quill Input Adaptor
Hollow Output Shaft
Bracket Mount

See Page 65

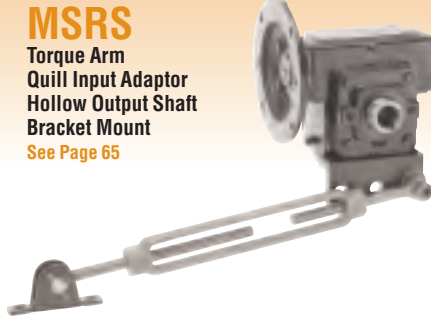

CSRS

Torque Arm
Coupled Input Adaptor
Hollow Output Shaft
Bracket Mount

See Page 65

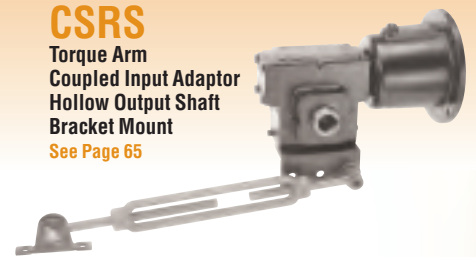

XSFS

Flange
Solid Input Shaft
Hollow Output Shaft
Flange Mount

See Page 66



MSFS

Flange
Quill Input Adaptor
Hollow Output Shaft
Flange Mount

See Page 67

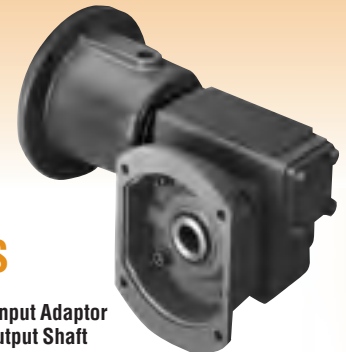

CSFS

Flange
Coupled Input Adaptor
Hollow Output Shaft
Flange Mount

See Page 67



XDNS Single Reduction Model

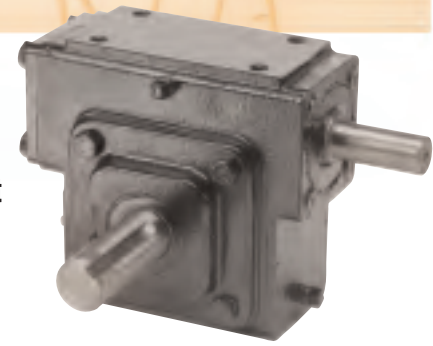

XDNS
Universal
Solid Input Shaft
Solid Output Shaft
Housing Mount

SHIPPING WEIGHTS (lb.) ♦								
MODEL	E13	E17	E20	E24	E26	E30	E35	E43
XDNS	15	20	23	40	43	53	82	151
MDNS	18	23	26	44	46	60	84	155
CDNS	21	27	29	53	56	72	91	156

All motorized weights are for 48C to 140TC adaptor sizes. Add 10% for 180TC/210TC adaptor sizes.

♦Weights are approximate and include shipping carton.

DIMENSIONS

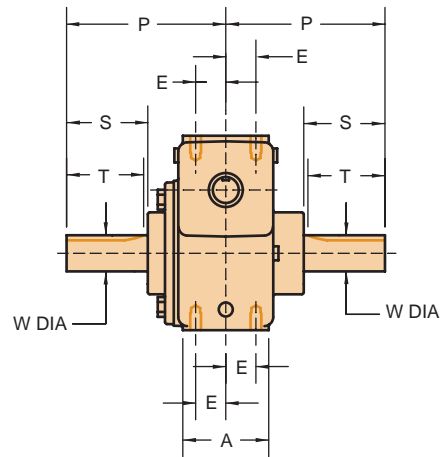
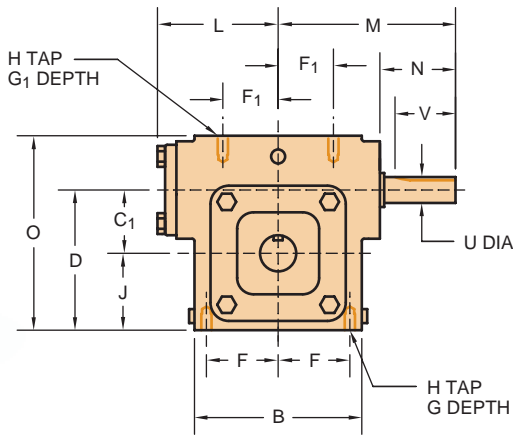

SPEED REDUCER DIMENSIONS (in.)

Size	A	B	C ₁	D	E	F	F ₁	H TAP	G DEPTH	G ₁ DEPTH	J	L	M	O	P	INPUT SHAFT			OUTPUT SHAFT				
																U*	N	V	KEYWAY	W*	S	T	KEYWAY
E13	2.00	3.88	1.333	3.08	.69	1.56	1.19	5/16-18	.56	.56	1.75	2.83	4.13	4.33	4.00	.625	1.81	1.63	3/16x3/32	.750	2.06	1.88	3/16x3/32
E17	2.38	4.63	1.750	3.88	.88	1.94	1.69	3/8-16	.63	.56	2.13	3.44	4.75	5.38	4.75	.750	1.94	1.69	3/16x3/32	1.000	2.56	2.31	1/4x1/8
E20	2.38	5.25	2.000	4.13	.88	2.19	1.69	3/8-16	.63	.56	2.13	3.44	5.00	5.63	4.75	.750	2.19	1.75	3/16x3/32	1.000	2.56	2.31	1/4x1/8
E24	3.13	5.38	2.375	5.25	1.13	2.19	2.19	1/2-13	.63	.57	2.88	4.50	6.50	7.25	5.50	1.000	2.75	2.38	1/4x1/8	1.250	2.81	2.63	1/4x1/8
E26	3.13	5.88	2.625	5.75	1.13	2.44	2.44	1/2-13	.69	.69	3.13	4.50	6.50	7.88	5.50	1.000	2.75	2.38	1/4x1/8	1.250	2.81	2.63	1/4x1/8
E30	3.50	6.62	3.000	6.50	1.31	2.75	2.75	1/2-13	.75	.75	3.50	4.63	7.00	9.00	5.88	1.000	3.06	2.38	1/4x1/8	1.370	2.88	2.75	5/16x5/32
E35	3.75	7.69	3.500	7.50	1.31	3.25	3.25	5/8-11	1.00	1.00	4.00	5.06†	7.38	10.13	7.00	1.000	2.31	2.50	1/4x1/8	1.750	3.75	3.63	3/8x3/16
E43	4.38	8.75	4.250	8.63	1.63	3.75	3.75	5/8-11	1.00	1.00	4.38	5.88‡	8.19	11.50	8.00	1.250	2.31	2.50	1/4x1/8	2.000	4.38	4.19	1/2x1/4

*Shaft diameter tolerances +.000 -.001 Dimensions shown are for construction purposes only. Please contact Winsmith for certified dimension sheets.
 † L dimension equals 5.46 on E35 MDNS model ‡ L dimension equals 6.28 on E43 MDNS model

AVAILABLE SHAFT ARRANGEMENTS AND RELATIVE SHAFT ROTATIONS

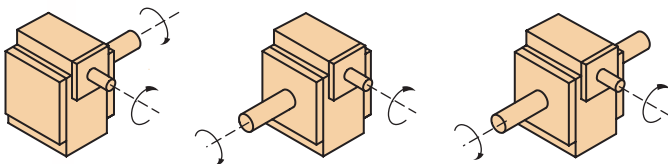

ASSEMBLY R

ASSEMBLY L

ASSEMBLY LR

The input shaft may be driven in either direction.



Integral

MDNS - CDNS Single Reduction Models

MDNS
Universal
Quill Input Adaptor
Solid Output Shaft
Housing Mount

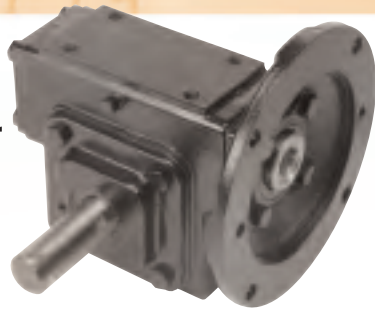

CDNS
Universal
Coupled Input Adaptor
Solid Output Shaft
Housing Mount

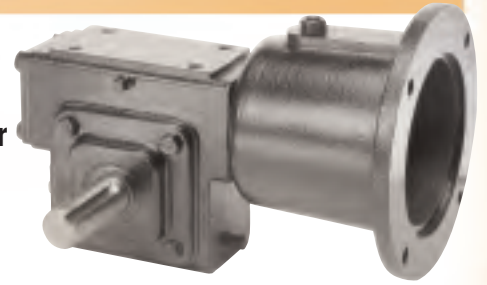

Couplings available, see page 106 for selection chart.

DIMENSIONS

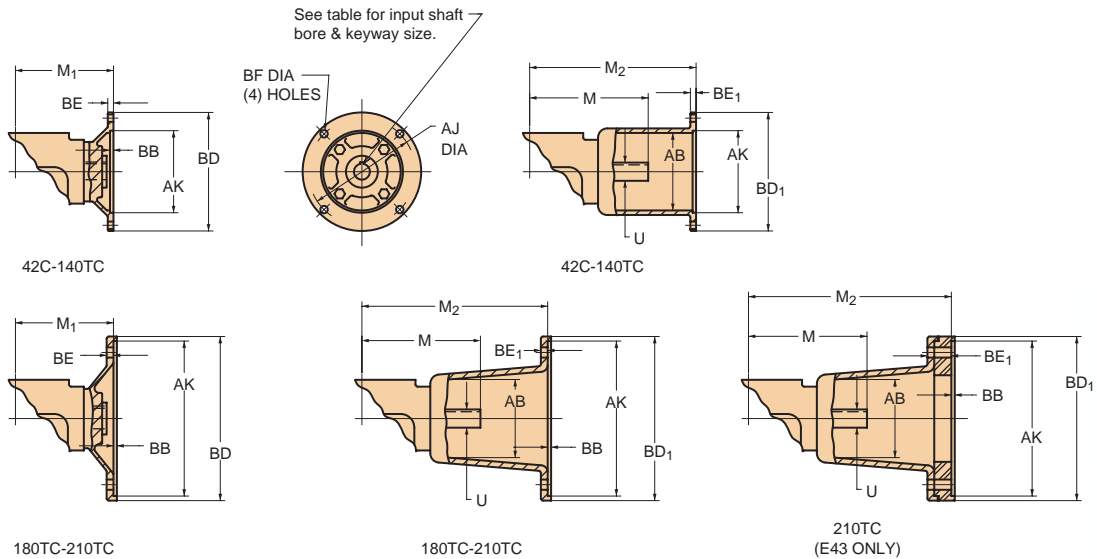

Size	QUILL INPUT ADAPTOR				COUPLED INPUT ADAPTOR														
	M ₁ 42C-48C	M ₁ 56C-140TC	M ₁ 180TC	M ₁ 210TC	42C-48C			56C-140TC			180TC			210TC			M	U	KEYWAY
					AB	M ₂	BE ₁	AB	M ₂	BE ₁	AB	M ₂	BE ₁	AB	M ₂	BE ₁			
E13	3.56	3.63*	NA	NA	2.50	6.81	.38	3.00	6.75	.31	NA			NA			4.13	.625	3/16 X 3/32
E17	4.06	4.06	NA	NA	2.50	7.56	.38	3.75	7.50	.38	3.75	8.44	.50	NA			4.75	.750	3/16 X 3/32
E20	4.06	4.06	NA	NA	2.50	7.56	.38	3.75	7.50	.38	3.75	8.44	.50	NA			5.00	.750	3/16 X 3/32
E24	NA	5.38	5.38	NA	NA			4.13	9.13	.38	4.25	10.19	.50	NA			6.50	1.000	1/4 X 1/8
E26	NA	5.38	5.38	NA	NA			4.13	9.13	.38	4.25	10.19	.50	NA			6.50	1.000	1/4 X 1/8
E30	NA	5.56	5.56	NA	NA			4.13	9.75	.38	4.75	10.88	.50	4.75	10.88	.50	7.00	1.000	1/4 X 1/8
E35	NA	5.81	5.81	NA	NA			4.13	10.00	.38	4.75	11.13	.50	4.75	11.13	.50	7.38	1.000	1/4 X 1/8
E43	NA	6.63	6.63	6.63	NA			4.13	10.81	.38	4.75	11.94	.50	4.75	12.88	1.44	8.19	1.250	1/4 X 1/8

*56C adaptor only

AVAILABLE SHAFT ARRANGEMENTS AND RELATIVE SHAFT ROTATIONS

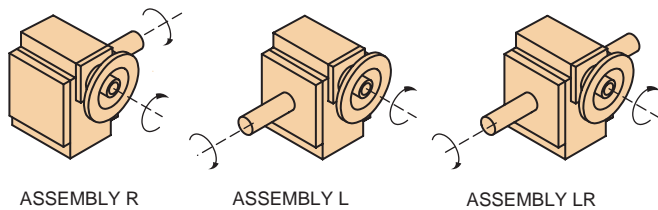

The input shaft may be driven in either direction.

INPUT ADAPT. DIM.	42C 48C	56C	140TC	180TC	210TC
AJ	3.75	5.88	5.88	7.25	7.25
AK	3.00	4.50	4.50	8.50	8.50
BB	.19	.19	.19	.19	.19
BD	4.50	6.50	6.50	9.00	9.00
BD ₁	4.50	6.63	6.63	9.00	9.00
BE	.34	.31	.31	.38	.38
BF	.281	.406	.406	.531	.531
KEYWAY	1/8 x 1/16	3/16 x 3/32		1/4 x 1/8	5/16 x 5/32
BORE	^{+0.001} -.000	.5005*	.6255	.8755	1.1255

*42C adaptor has .3755 bore, 3/32 X 3/64 keyway



2D DRAWINGS & 3D MODELS
www.WINSMITH.com



XDTS Single Reduction Model

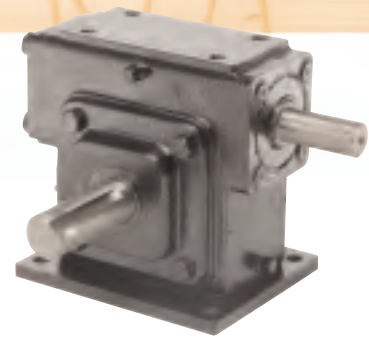

XDTS
Worm-On-Top
Solid Input Shaft
Solid Output Shaft
Base Mount

SHIPPING WEIGHTS (lb.) ♦								
MODEL	E13	E17	E20	E24	E26	E30	E35	E43
XDTS	16	23	25	43	45	60	91	163
MDTS	19	26	28	46	49	66	95	170
CDTS	24	31	33	54	56	72	115	175

All motorized weights are for 48C to 140TC adaptor sizes. Add 10% for 180TC/210TC adaptor sizes.

♦ Weights are approximate and include shipping carton.

DIMENSIONS

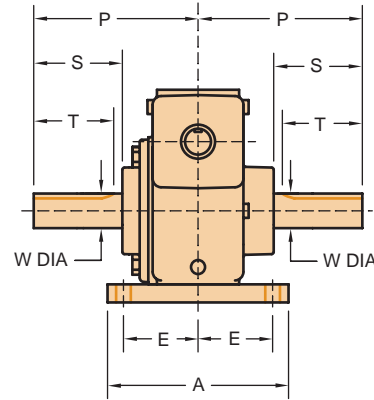
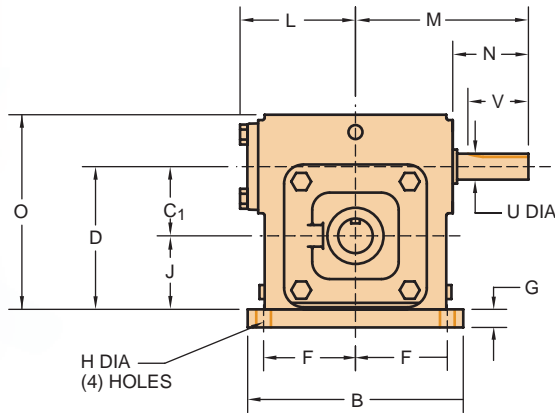

SPEED REDUCER DIMENSIONS (in.)

Size	A	B	C ₁	D	E	F	G	H	J	L	M	O	P	INPUT SHAFT			OUTPUT SHAFT				
														U*	N	V	KEYWAY	W*	S	T	KEYWAY
E13	4.00	5.00	1.333	3.33	1.63	2.13	.25	.281	2.00	2.83	4.13	4.58	4.00	.625	1.81	1.63	3/16x3/32	.750	2.06	1.88	3/16x3/32
E17	4.50	5.50	1.750	4.19	1.75	2.31	.31	.406	2.44	3.44	4.75	5.69	4.75	.750	1.94	1.69	3/16x3/32	1.000	2.56	2.31	1/4x1/8
E20	4.50	5.88	2.000	4.63	1.88	2.50	.50	.406	2.63	3.44	5.00	6.13	4.75	.750	2.19	1.75	3/16x3/32	1.000	2.56	2.31	1/4x1/8
E24	4.50	7.00	2.375	5.63	1.88	3.13	.38	.406	3.25	4.50	6.50	7.63	5.50	1.000	2.75	2.38	1/4x1/8	1.250	2.81	2.63	1/4x1/8
E26	4.50	7.50	2.625	6.13	1.88	3.25	.38	.406	3.50	4.50	6.50	8.25	5.50	1.000	2.75	2.38	1/4x1/8	1.250	2.81	2.63	1/4x1/8
E30	6.00	8.00	3.000	7.00	2.38	3.50	.50	.563	4.00	4.63	7.00	9.50	5.88	1.000	3.06	2.38	1/4x1/8	1.375	2.88	2.75	5/16x5/32
E35	6.50	10.00	3.500	8.00	2.63	4.13	.50	.563	4.50	5.06†	7.38	10.63	7.00	1.000	2.31	2.50	1/4x1/8	1.750	3.75	3.63	3/8x3/16
E43	7.00	11.00	4.250	9.25	2.88	4.88	.63	.563	5.00	5.88‡	8.19	12.13	8.00	1.250	2.31	2.50	1/4x1/8	2.000	4.38	4.19	1/2x1/4

*Shaft diameter tolerances +.000-.001 Dimensions shown are for construction purposes only. Please contact Winsmith for certified dimension sheets.

† L dimension equals 5.46 on E35 MDTS model ‡ L dimension equals 6.28 on E43 MDTS model

AVAILABLE SHAFT ARRANGEMENTS AND RELATIVE SHAFT ROTATIONS

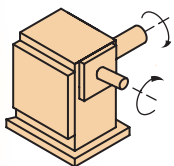

ASSEMBLY R

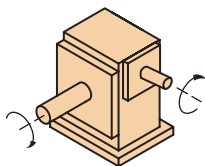

ASSEMBLY L

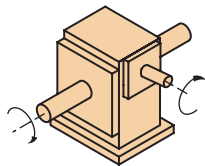

ASSEMBLY LR

The input shaft may be driven in either direction.



MDTS - CDTs Single Reduction Models

MDTS
Worm-On-Top
Quill Input Adaptor
Solid Output Shaft
Base Mount



CDTS
Worm-On-Top
Coupled Input Adaptor
Solid Output Shaft
Base Mount

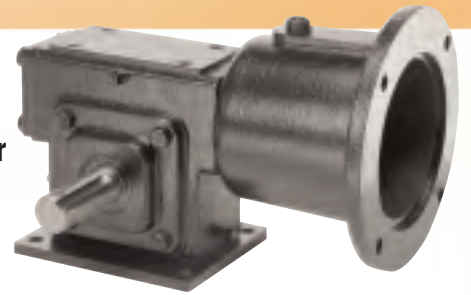

Couplings available, see page 106 for selection chart.

DIMENSIONS

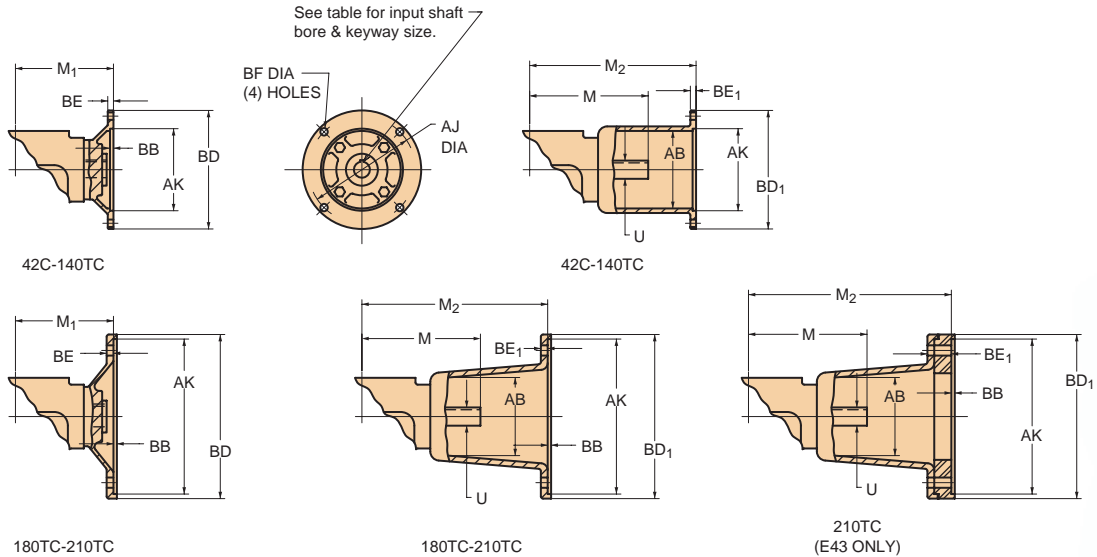

Size	QUILL INPUT ADAPTOR				COUPLED INPUT ADAPTOR														
	M ₁ 42C-48C	M ₁ 56C-140TC	M ₁ 180TC	M ₁ 210TC	42C-48C			56C-140TC			180TC			210TC			M	U	KEYWAY
					AB	M ₂	BE ₁	AB	M ₂	BE ₁	AB	M ₂	BE ₁	AB	M ₂	BE ₁			
E13	3.56	3.63*	NA	NA	2.50	6.81	.38	3.00	6.75	.31	NA			4.13	.625	3/16x3/32			
E17	4.06	4.06	NA	NA	2.50	7.56	.38	3.75	7.50	.38	3.75	8.44	.50	NA			4.75	.750	3/16x3/32
E20	4.06	4.06	NA	NA	2.50	7.56	.38	3.75	7.50	.38	3.75	8.44	.50	NA			5.00	.750	3/16x3/32
E24	NA	5.38	5.38	NA	NA			4.13	9.13	.38	4.25	10.19	.50	NA			6.50	1.000	1/4x1/8
E26	NA	5.38	5.38	NA	NA			4.13	9.13	.38	4.25	10.19	.50	NA			6.50	1.000	1/4x1/8
E30	NA	5.56	5.56	NA	NA			4.13	9.75	.38	4.75	10.88	.50	4.75	10.88	.50	7.00	1.000	1/4x1/8
E35	NA	5.81	5.81	NA	NA			4.13	10.00	.38	4.75	11.13	.50	4.75	11.13	.50	7.38	1.000	1/4x1/8
E43	NA	6.63	6.63	6.63	NA			4.13	10.81	.38	4.75	11.94	.50	4.75	12.88	1.44	8.19	1.250	1/4x1/8

*56C adaptor only

AVAILABLE SHAFT ARRANGEMENTS AND RELATIVE SHAFT ROTATIONS

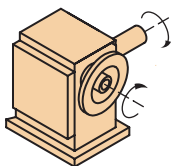

ASSEMBLY R

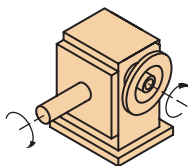

ASSEMBLY L

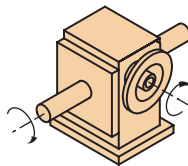

ASSEMBLY LR

The input shaft may be driven in either direction.

INPUT ADAPT. DIM.	42C 48C	56C	140TC	180TC	210TC
AJ	3.75	5.88	5.88	7.25	7.25
AK	3.00	4.50	4.50	8.50	8.50
BB	.19	.19	.19	.19	.19
BD	4.50	6.50	6.50	9.00	9.00
BD ₁	4.50	6.63	6.63	9.00	9.00
BE	.34	.31	.31	.38	.38
BF	.281	.406	.406	.531	.531
KEYWAY	1/8 x 1/16	3/16 x 3/32		1/4 x 1/8	5/16 x 5/32
BORE	^{+0.001} -.000	.5005*	.6255	.8755	1.1255

*42C adaptor has .3755 bore, 3/32 x 3/64 keyway



2D DRAWINGS & 3D MODELS
www.WINSMITH.com



XDBS Single Reduction Model

XDBS
Worm-On-Bottom
Solid Input Shaft
Solid Output Shaft
Base Mount

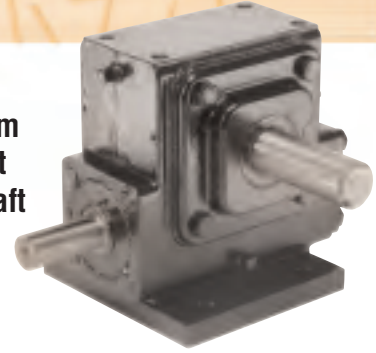

SHIPPING WEIGHTS (lb.) ♦								
MODEL	E13	E17	E20	E24	E26	E30	E35	E43
XDBS	16	24	24	43	46	62	96	170
MDBS	20	27	27	47	50	66	120	175
CDBS	0	30	34	56	60	78	127	183

All motorized weights are for 48C to 140TC adaptor sizes. Add 10% for 180TC/210TC adaptor sizes.

♦Weights are approximate and include shipping carton.

DIMENSIONS

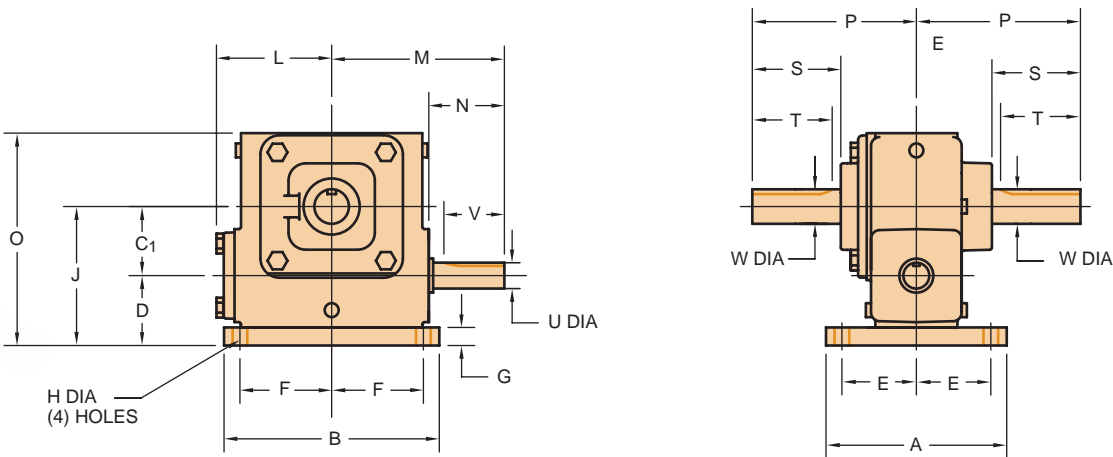

SPEED REDUCER DIMENSIONS (in.)

Size	A	B	C ₁	D	E	F	G	H	J	L	M	O	P	INPUT SHAFT			OUTPUT SHAFT				
														U*	N	V	KEYWAY	W*	S	T	KEYWAY
E13	3.50	5.00	1.333	1.63	1.38	2.13	.38	.281	2.96	2.83	4.13	4.71	4.00	.625	1.81	1.63	3/16x3/32	.750	2.06	1.88	3/16x3/32
E17	5.00	4.63	1.750	2.00	2.06	1.44	.50	.406	3.75	3.44	4.75	5.88	4.75	.750	1.94	1.69	3/16x3/32	1.000	2.56	2.31	1/4x1/8
E20	5.00	4.63	2.000	2.00	2.06	1.44	.50	.406	4.00	3.44	5.00	6.13	4.75	.750	2.19	1.75	3/16x3/32	1.000	2.56	2.31	1/4x1/8
E24	5.00	7.00	2.375	2.38	2.00	3.00	.38	.406	4.75	4.50	6.50	7.63	5.50	1.000	2.75	2.38	1/4x1/8	1.250	2.81	2.63	1/4x1/8
E26	4.75	7.00	2.625	2.50	2.00	3.00	.38	.406	5.13	4.50	6.50	8.25	5.50	1.000	2.75	2.38	1/4x1/8	1.250	2.81	2.63	1/4x1/8
E30	6.00	8.00	3.000	3.00	2.38	3.50	.50	.563	6.00	4.63	7.00	9.50	5.88	1.000	3.06	2.38	1/4x1/8	1.370	2.88	2.75	5/16x5/32
E35	6.50	10.00	3.500	3.13	2.63	4.13	.50	.563	6.63	6.63	7.38	10.63	7.00	1.000	2.31	2.50	1/4x1/8	1.750	3.75	3.63	3/8x3/16
E43	7.00	11.00	4.250	3.50	2.88	4.88	.63	.563	7.75	5.88†	8.19	12.13	8.00	1.250	2.31	2.50	1/4x1/8	2.000	4.38	4.19	1/2x1/4

*Shaft diameter tolerances +.000 -.001 Dimensions shown are for construction purposes only. Please contact Winsmith for certified dimension sheets.
† L dimension equals 5.46 on E35 MDBS model ‡ L dimension equals 6.28 on E43 MDBS model

AVAILABLE SHAFT ARRANGEMENTS AND RELATIVE SHAFT ROTATIONS

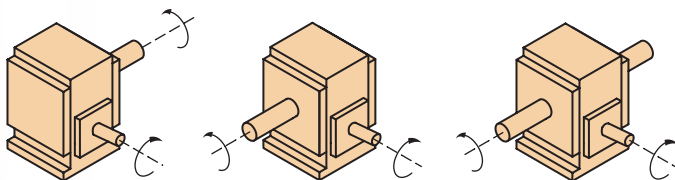

ASSEMBLY R

ASSEMBLY L

ASSEMBLY LR

The input shaft may be driven in either direction.



MDBS - CDBS Single Reduction Models

MDBS
Worm-On-Bottom
Quill Input Adaptor
Solid Output Shaft
Base Mount



CDBS
Worm-On-Bottom
Coupled Input Adaptor
Solid Output Shaft
Base Mount

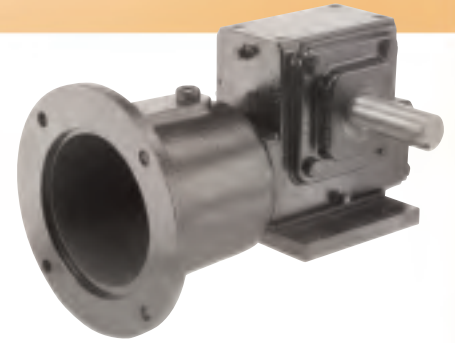

Couplings available, see page 106 for selection chart.

DIMENSIONS

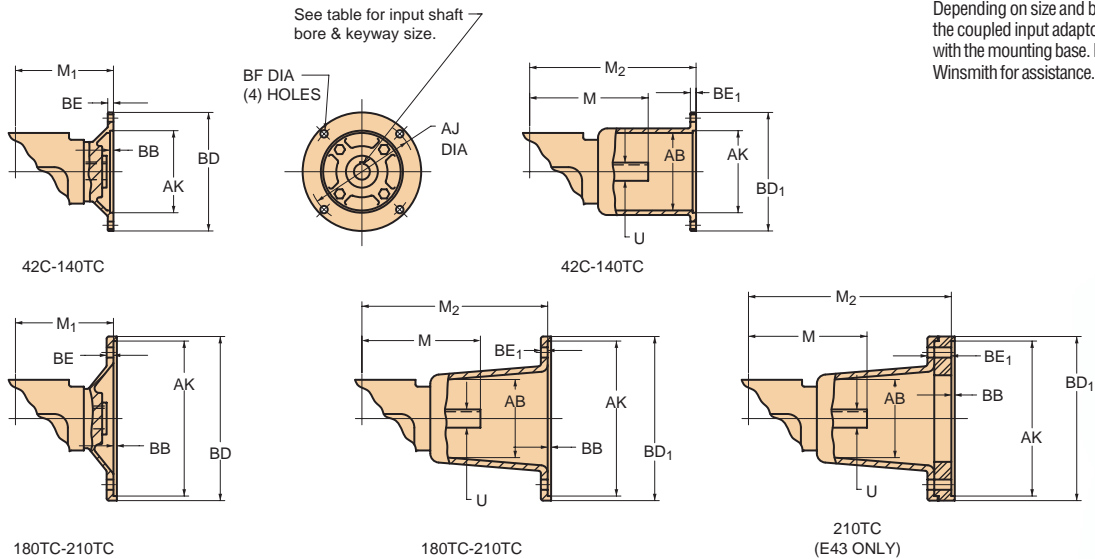

Depending on size and base selection, the coupled input adaptor may interfere with the mounting base. Please contact Winsmith for assistance.

Size	QUILL INPUT ADAPTOR				COUPLED INPUT ADAPTOR														
	M ₁ 42C-48C	M ₁ 56C-140TC	M ₁ 180TC	M ₁ 210TC	42C-48C			56C-140TC			180TC			210TC			M	U	KEYWAY
	AB	M ₂	BE ₁	AB	M ₂	BE ₁	AB	M ₂	BE ₁	AB	M ₂	BE ₁							
E13	3.56	3.63*	NA	NA	2.50	6.81	.38	3.00	6.75	.31	NA			4.13	.625	3/16x3/32			
E17	4.06	4.06	NA	NA	2.50	7.56	.38	3.75	7.50	.38	3.75	8.44	.50	4.75	.750	3/16x3/32			
E20	4.06	4.06	NA	NA	2.50	7.56	.38	3.75	7.50	.38	3.75	8.44	.50	5.00	.750	3/16x3/32			
E24	NA	5.38	5.38	NA	NA			4.13	9.13	.38	4.25	10.19	.50	6.50	1.000	1/4x1/8			
E26	NA	5.38	5.38	NA	NA			4.13	9.13	.38	4.25	10.19	.50	6.50	1.000	1/4x1/8			
E30	NA	5.56	5.56	NA	NA			4.13	9.75	.38	4.75	10.88	.50	7.00	1.000	1/4x1/8			
E35	NA	5.81	5.81	NA	NA			4.13	10.00	.38	4.75	11.13	.50	7.38	1.000	1/4x1/8			
E43	NA	6.63	6.63	6.63	NA			4.13	10.81	.38	4.75	11.94	.50	8.19	1.250	1/4x1/8			

*56C adaptor only

AVAILABLE SHAFT ARRANGEMENTS AND RELATIVE SHAFT ROTATIONS

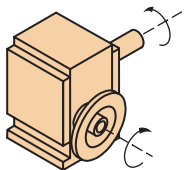

ASSEMBLY R

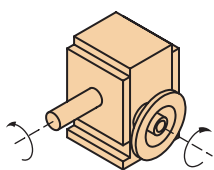

ASSEMBLY L

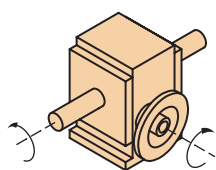

ASSEMBLY LR

The input shaft may be driven in either direction.

INPUT ADAPT. DIM.	42C 48C	56C	140TC	180TC	210TC
AJ	3.75	5.88	5.88	7.25	7.25
AK	3.00	4.50	4.50	8.50	8.50
BB	.19	.19	.19	.19	.19
BD	4.50	6.50	6.50	9.00	9.00
BD ₁	4.50	6.63	6.63	9.00	9.00
BE	.34	.31	.31	.38	.38
BF	.281	.406	.406	.531	.531
KEYWAY	1/8 x 1/16	3/16 x 3/32		1/4 x 1/8	5/16 x 5/32
BORE	$^{+.001}_{-.000}$.5005*	.6255	.8755	1.1255

*42C adaptor has .3755 bore, 3/32 x 3/64 keyway



2D DRAWINGS & 3D MODELS
www.WINSMITH.com



XDJS Single Reduction Model

SHIPPING WEIGHTS (lb.) ♦								
MODEL	E13	E17	E20	E24	E26	E30	E35	E43
XDJS	16	23	25	45	46	60	97	124
MDJS	20	27	30	50	53	69	101	129
CDJS	21	36	32	54	55	80	104	134

All motorized weights are for 48C to 140TC adaptor sizes. Add 10% for 180TC/210TC adaptor sizes.

♦Weights are approximate and include shipping carton.

XDJS
"J" Vertical
Solid Input Shaft
Solid Output Shaft
Bracket Mount

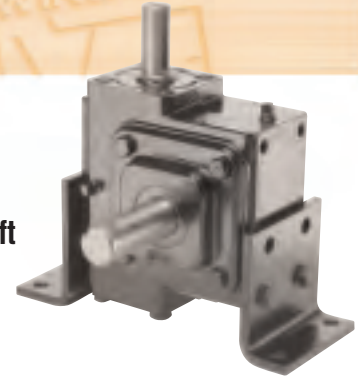

DIMENSIONS

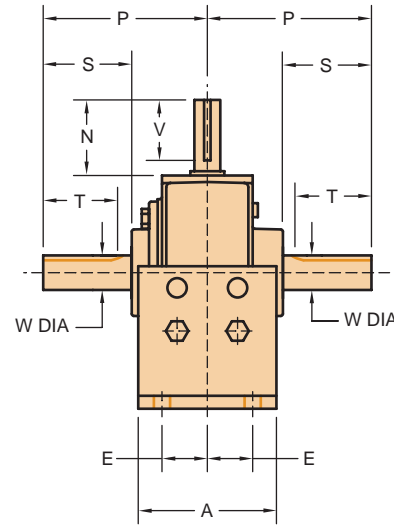
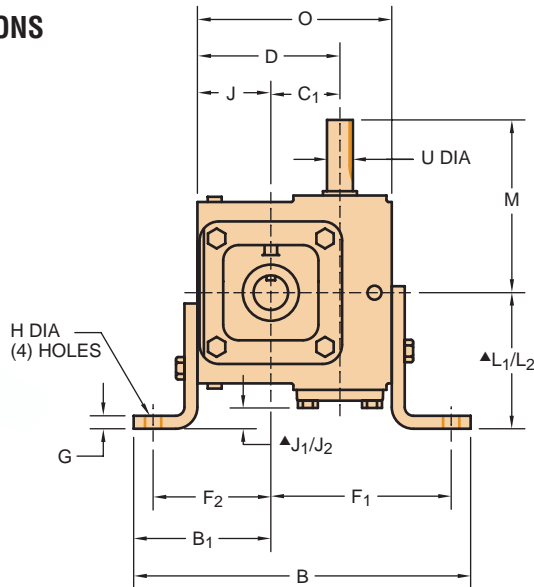

SPEED REDUCER DIMENSIONS (in.)

Size	A	B	B ₁	C ₁	D	E	F ₁	F ₂	G	H _{DIA}	J	L ₁	J ₁	L ₂	J ₂	M	O	P	INPUT SHAFT			OUTPUT SHAFT				
																			U*	N	V	KEYWAY	W*	S	T	KEYWAY
E13	3.00	7.43	3.10	1.333	3.08	1.00	3.82	2.60	.25	.344	1.75	2.94	.11	4.31	1.48	4.13	4.33	4.00	.625	1.81	1.63	3/16x3/32	.750	2.06	1.88	3/16x3/32
E17	3.50	8.63	3.50	1.750	3.88	1.25	4.63	3.00	.25	.406	2.13	3.50	.06	4.79	1.35	4.75	5.38	4.75	.750	1.94	1.69	3/16x3/32	1.000	2.56	2.31	1/4x1/8
E20	4.00	9.75	3.97	2.000	4.13	1.31	5.22	3.41	.38	.469	2.13	3.94	.05	5.32	.43	5.00	5.63	4.75	.750	2.19	1.75	3/16x3/32	1.000	2.56	2.31	1/4x1/8
E24	4.00	10.75	4.63	2.375	5.25	1.44	5.56	4.06	.38	.469	2.88	4.63	.13	6.50	2.00	6.50	7.25	5.50	1.000	2.75	2.38	1/4x1/8	1.250	2.81	2.63	1/4x1/8
E26	4.50	11.63	4.75	2.625	5.75	1.56	6.25	4.13	.38	.531	3.13	4.75	.25	6.50	2.00	6.50	7.88	5.50	1.000	2.75	2.38	1/4x1/8	1.250	2.81	2.63	1/4x1/8
E30	5.50	12.50	5.25	3.000	6.50	2.00	6.63	4.63	.38	.531	3.50	4.75	.13	7.00	2.37	7.00	9.00	5.88	1.000	3.06	2.38	1/4x1/8	1.375	2.88	2.75	5/16x5/32
E35	5.50	14.50	6.19	3.500	7.50	2.00	7.56	5.19	.38	.531	4.00	5.69	.75†	8.13	3.19	7.38	10.13	7.00	1.000	2.31	2.50	1/4x1/8	1.750	3.75	3.63	3/8x3/16
E43	6.50	15.88	6.56	4.250	8.63	2.50	8.56	5.81	.38	.656	4.38	6.50	.63†	8.88	3.01	8.19	11.50	8.00	1.250	2.31	2.50	1/4x1/8	2.000	4.38	4.19	3/8x3/16

*Shaft diameter tolerances +.000 -.001. Dimensions shown are for construction purposes only. Please contact Winsmith for certified dimension sheets.

† J₁ dimension equals .23 on E35 MDJS model and .22 on E43 MDJS model

▲ L₂ and J₂ dimensions apply when using top two mounting holes on bracket

AVAILABLE SHAFT ARRANGEMENTS AND RELATIVE SHAFT ROTATIONS

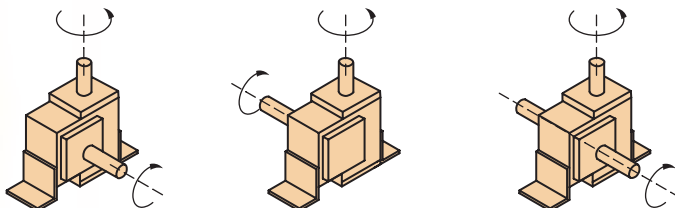

ASSEMBLY R

ASSEMBLY L

ASSEMBLY LR

The input shaft may be driven in either direction.



MDJS - CDJS Single Reduction Models

MDJS
 "J" Vertical
 Quill Input Adaptor
 Solid Output Shaft
 Bracket Mount



CDJS
 "J" Vertical
 Coupled Input Adaptor
 Solid Output Shaft
 Bracket Mount



Couplings available, see page 106 for selection chart.

DIMENSIONS

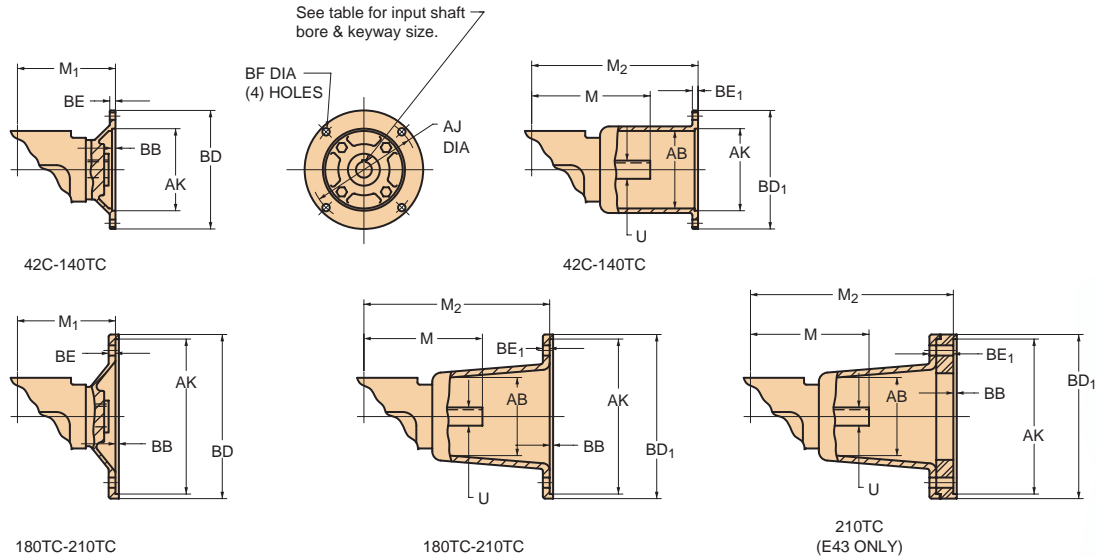

Size	QUILL INPUT ADAPTOR				COUPLED INPUT ADAPTOR														
	M ₁ 42C-48C	M ₁ 56C-140TC	M ₁ 180TC	M ₁ 210TC	42C-48C			56C-140TC			180TC			210TC		M	U	KEYWAY	
	AB	M ₂	BE ₁	AB	M ₂	BE ₁	AB	M ₂	BE ₁	AB	M ₂	BE ₁							
E13	3.56	3.63*	NA	NA	2.50	6.81	.38	3.00	6.75	.31	NA			NA		4.13	.625	1/8 x 1/16	
E17	4.06	4.06	NA	NA	2.50	7.56	.38	3.75	7.50	.38	3.75	8.44	.50	NA		4.75	.750	3/16 x 3/32	
E20	4.06	4.06	NA	NA	2.50	7.56	.38	3.75	7.50	.38	3.75	8.44	.50	NA		5.00	.750	3/16 x 3/32	
E24	NA	5.38	5.38	NA	NA			4.13	9.13	.38	4.25	10.19	.50	NA		6.50	1.000	1/4 x 1/8	
E26	NA	5.38	5.38	NA	NA			4.13	9.13	.38	4.25	10.19	.50	NA		6.50	1.000	1/4 x 1/8	
E30	NA	5.56	5.56	NA	NA			4.13	9.75	.38	4.75	10.88	.50	4.75	10.88	.50	7.00	1.000	1/4 x 1/8
E35	NA	5.81	5.81	NA	NA			4.13	10.00	.38	4.75	11.13	.50	4.75	11.13	.50	7.38	1.000	1/4 x 1/8
E43	NA	6.63	6.63	6.63	NA			4.13	10.81	.38	4.75	11.94	.50	4.75	12.88	1.44	8.19	1.250	1/4 x 1/8

*56C adaptor only

AVAILABLE SHAFT ARRANGEMENTS AND RELATIVE SHAFT ROTATIONS

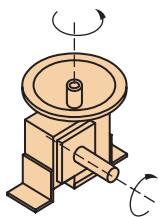

ASSEMBLY R

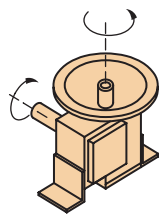

ASSEMBLY L

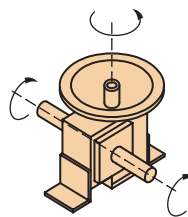

ASSEMBLY LR

The input shaft may be driven in either direction.

INPUT ADAPT. DIM.	42C 48C	56C	140TC	180TC	210TC
AJ	3.75	5.88	5.88	7.25	7.25
AK	3.00	4.50	4.50	8.50	8.50
BB	.19	.19	.19	.19	.19
BD	4.50	6.50	6.50	9.00	9.00
BD ₁	4.50	6.63	6.63	9.00	9.00
BE	.34	.31	.31	.38	.38
BF	.281	.406	.406	.531	.531
KEYWAY	1/8 x 1/16	3/16 x 3/32		1/4 x 1/8	5/16 x 5/32
BORE	$\begin{matrix} +.001 \\ -.000 \end{matrix}$.5005*	.6255	.8755	1.1255

*42C adaptor has .3755 bore, 3/32 x 3/64 keyway



2D DRAWINGS & 3D MODELS
 www.WINSMITH.com



XDUS Single Reduction Model



XDUS
 "U" Flange
 Solid Input Shaft
 Solid Output Shaft
 Bracket Mount

SHIPPING WEIGHTS (lb.) ♦							
MODEL	E17	E20	E24	E26	E30	E35	E43
XSHS	24	29	46	50	63	93	164
MSSH	27	32	50	53	70	95	168
CSHS	31	35	59	63	82	102	169

All motorized weights are for 48C to 140TC adaptor sizes. Add 10% for 180TC/210TC adaptor sizes.

♦Weights are approximate and include shipping carton.

DIMENSIONS

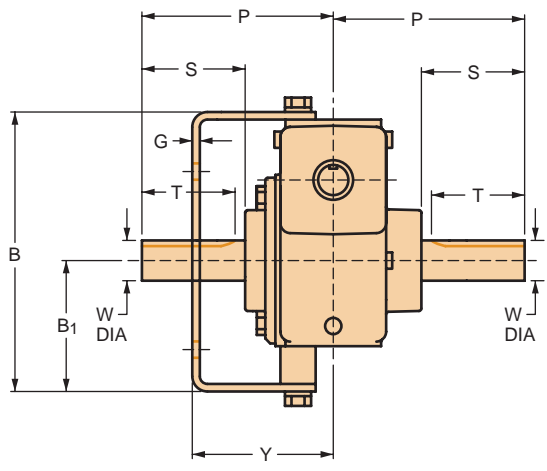
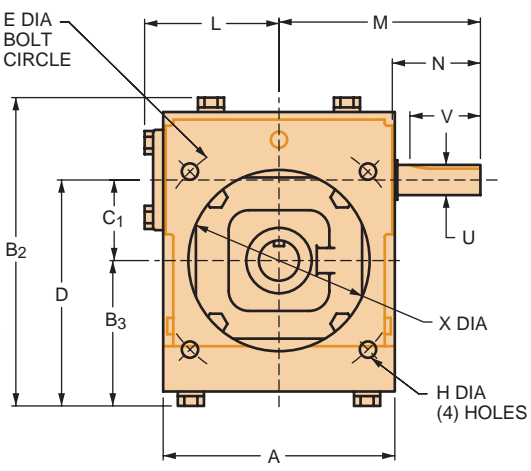

SPEED REDUCER DIMENSIONS (in.)

Size	A	B	B ₁	B ₂	B ₃	C ₁	D	E	G	H	L	M	P	X	Y	INPUT SHAFT			OUTPUT SHAFT				
																U*	N	V	KEYWAY	W*	S	T	KEYWAY
E17	4.81	6.25	2.81	7.02	3.20	1.750	4.95	5.875	.19	.344	3.44	4.75	4.75	4.06	3.50	.750	1.94	1.69	3/16x3/32	1.000	2.56	2.31	1/4x1/8
E20	5.75	6.94	3.25	7.71	3.64	2.000	5.64	6.500	.19	.406	3.44	5.00	4.75	4.50	3.50	.750	2.19	1.75	3/16x3/32	1.000	2.56	2.31	1/4x1/8
E24	6.13	8.00	3.44	9.03	3.96	2.375	6.34	7.500	.19	.406	4.50	6.50	5.50	5.05	3.69	1.000	2.75	2.38	1/4x1/8	1.250	2.81	2.63	1/4x1/8
E26	7.19	8.63	3.63	9.66	4.14	2.625	6.77	8.000	.25	.406	4.50	6.50	5.50	6.00	3.82	1.000	2.75	2.38	1/4x1/8	1.250	2.81	2.63	1/4x1/8
E30	8.50	10.19	4.44	11.22	4.95	3.000	7.95	9.250	.25	.563	4.63	7.00	5.88	7.00	5.00	1.000	3.06	2.38	1/4x1/8	1.375	2.88	2.75	5/16x5/32
E35	8.50	11.00	4.63	12.27	5.26	3.500	8.76	10.000	.25	.563	5.06†	7.38	7.00	7.00	5.06	1.000	2.31	2.50	1/4x1/8	1.750	3.75	3.63	3/8x3/16
E43	10.00	13.00	5.50	14.27	6.13	4.250	10.38	11.500	.38	.688	5.88‡	8.19	8.00	8.00	5.75	1.250	2.31	2.50	1/4x1/8	2.000	4.38	4.19	1/2x1/4

* Shaft diameter tolerances +.000 -.001 Dimensions shown are for construction purposes only. Please contact Winsmith for certified dimension sheets.
 † L dimension equals 5.46 on E35 MDUS model ‡ L dimension equals 6.28 on E43 MDUS model

AVAILABLE SHAFT ARRANGEMENTS AND RELATIVE SHAFT ROTATIONS

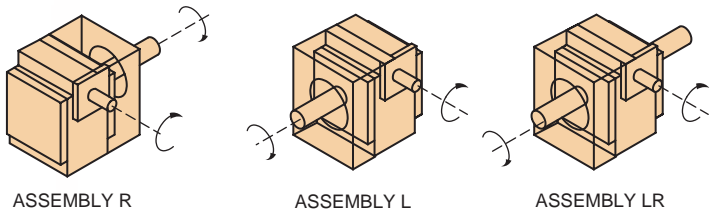

The input shaft may be driven in either direction.



Integral

MDUS - CDUS Single Reduction Models

MDUS
 "U" Flange
 Quill Input Adaptor
 Solid Output Shaft
 Bracket Mount



CDUS
 "U" Flange
 Coupled Input Adaptor
 Solid Output Shaft
 Bracket Mount

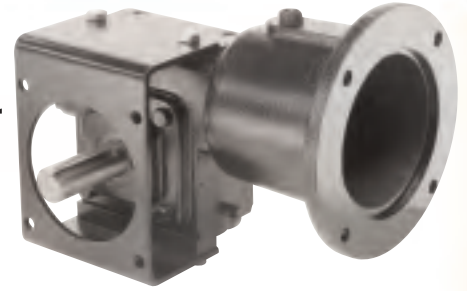

Couplings available, see page 106 for selection chart.

DIMENSIONS

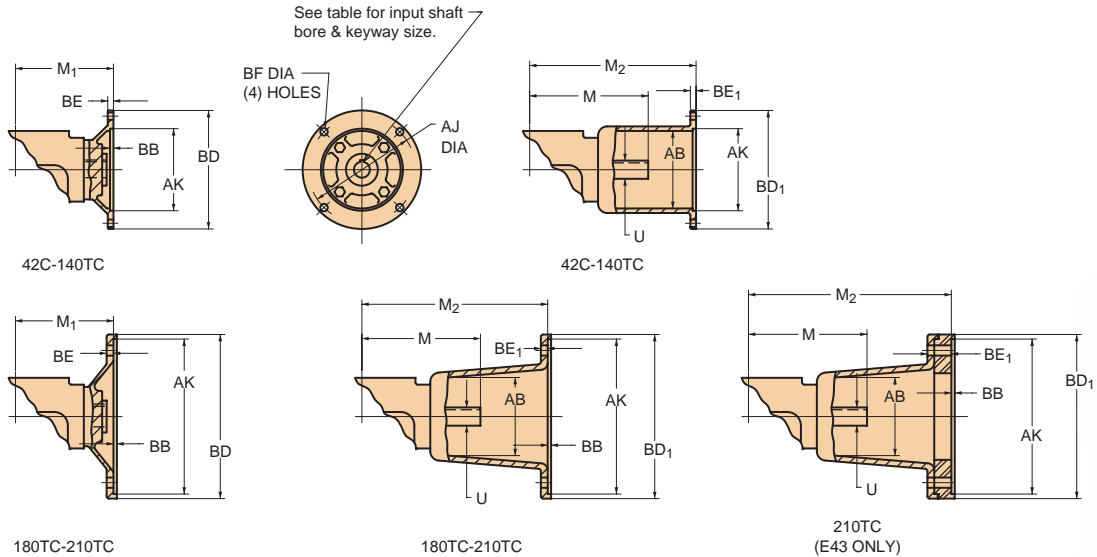

Size	QUILL INPUT ADAPTOR				COUPLED INPUT ADAPTOR														
	M ₁ 42C-48C	M ₁ 56C-140TC	M ₁ 180TC	M ₁ 210TC	42C-48C			56C-140TC			180TC			210TC			M	U	KEYWAY
					AB	M ₂	BE ₁	AB	M ₂	BE ₁	AB	M ₂	BE ₁	AB	M ₂	BE ₁			
E17	4.06	4.06	NA	NA	2.50	7.56	.38	3.75	7.50	.38	3.75	8.44	.50	NA			4.75	.750	3/16 x 3/32
E20	4.06	4.06	NA	NA	2.50	7.56	.38	3.75	7.50	.38	3.75	8.44	.50	NA			5.00	.750	3/16 x 3/32
E24	NA	5.38	5.38	NA	NA			4.13	9.13	.38	4.25	10.19	.50	NA			6.50	1.000	1/4 x 1/8
E26	NA	5.38	5.38	NA	NA			4.13	9.13	.38	4.25	10.19	.50	NA			6.50	1.000	1/4 x 1/8
E30	NA	5.56	5.56	NA	NA			4.13	9.75	.38	4.75	10.88	.50	4.75	10.88	.50	7.00	1.000	1/4 x 1/8
E35	NA	5.81	5.81	NA	NA			4.13	10.00	.38	4.75	11.13	.50	4.75	11.13	.50	7.38	1.000	1/4 x 1/8
E43	NA	6.63	6.63	6.63	NA			4.13	10.81	.38	4.75	11.94	.50	4.75	12.88	1.44	8.19	1.250	1/4 x 1/8

AVAILABLE SHAFT ARRANGEMENTS AND RELATIVE SHAFT ROTATIONS

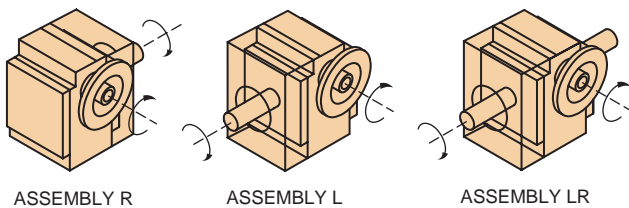

The input shaft may be driven in either direction.

INPUT ADAPT. DIM.	42C 48C	56C	140TC	180TC	210TC
AJ	3.75	5.88	5.88	7.25	7.25
AK	3.00	4.50	4.50	8.50	8.50
BB	.19	.19	.19	.19	.19
BD	4.50	6.50	6.50	9.00	9.00
BD ₁	4.50	6.63	6.63	9.00	9.00
BE	.34	.31	.31	.38	.38
BF	.281	.406	.406	.531	.531
KEYWAY	1/8 x 1/16	3/16 x 3/32		1/4 x 1/8	5/16 x 5/32
BORE	$^{+.001}_{-.000}$.5005*	.6255	.8755	1.1255

*42C adaptor has .3755 bore, 3/32 x 3/64 keyway



2D DRAWINGS & 3D MODELS
 www.WINSMITH.com



XDHS Single Reduction Model



SHIPPING WEIGHTS (lb.) ♦						
MODEL	E17	E20	E24	E26	E30	E35
XSHS	24	28	46	49	59	93
MSHS	27	31	50	52	66	95
CSHS	31	34	59	62	78	102

All motorized weights are for 48C to 140TC adaptor sizes. Add 10% for 180TC/210TC adaptor sizes.

♦Weights are approximate and include shipping carton.

XDHS
Hanger
Solid Input Shaft
Solid Output Shaft
Bracket Mount

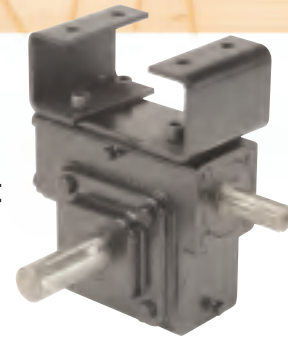

DIMENSIONS

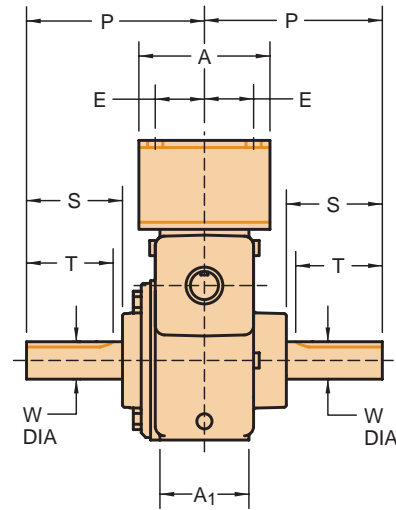
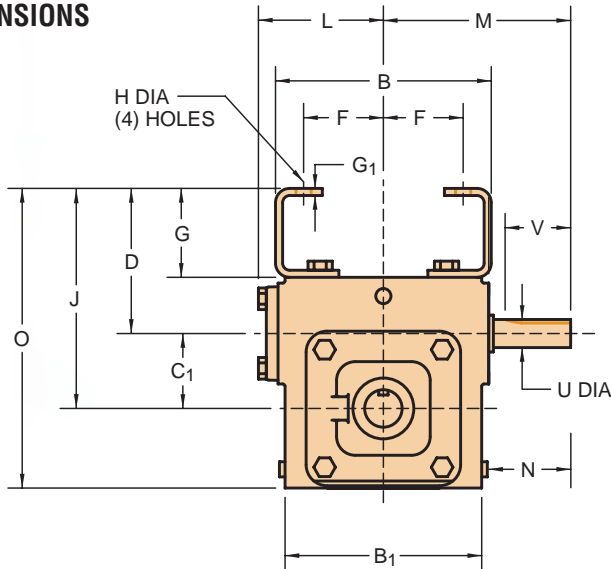

SPEED REDUCER DIMENSIONS (in.)

Size	A	A ₁	B	B ₁	C ₁	D	E	F	G	G ₁	H	J	L	M	O	P	INPUT SHAFT			OUTPUT SHAFT				
																	U*	N	V	KEYWAY	W*	S	T	KEYWAY
E17	3.38	2.38	5.75	4.63	1.750	3.88	.88	1.94	2.38	.19	.390	5.63	3.44	4.75	7.75	4.75	.750	1.94	1.69	3/16x3/32	1.000	2.56	2.31	1/4x1/8
E20	3.50	2.38	5.88	5.25	2.000	3.88	.88	2.19	2.38	.19	.390	5.88	3.44	5.00	8.00	4.75	.750	2.19	1.75	3/16x3/32	1.000	2.56	2.31	1/4x1/8
E24	4.13	3.13	7.75	5.38	2.375	4.50	1.13	2.19	2.50	.25	.515	6.88	4.50	6.50	9.75	5.50	1.000	2.75	2.38	1/4x1/8	1.250	2.81	2.63	1/4x1/8
E26	4.13	3.13	8.25	5.88	2.625	4.63	1.13	2.44	2.50	.25	.515	7.25	4.50	6.50	10.38	5.50	1.000	2.75	2.38	1/4x1/8	1.250	2.81	2.63	1/4x1/8
E30	5.50	3.50	8.88	6.62	3.000	5.50	2.19	3.31	3.00	.25	.531	8.50	4.63	7.00	12.00	5.88	1.000	3.06	2.38	1/4x1/8	1.375	2.88	2.75	5/16x5/32
E35	5.02	3.75	9.25	7.69	3.500	5.00	1.31	3.25	2.38	.31	.656	8.50	5.06†	7.38	12.50	7.00	1.000	2.31	2.50	1/4x1/8	1.750	3.75	3.63	3/8x3/16

* Shaft diameter tolerances +.000 -.001. Dimensions shown are for construction purposes only. Please contact Winsmith for certified dimension sheets.
 † L dimension equals 5.46 on E35 MDHS model

AVAILABLE SHAFT ARRANGEMENTS AND RELATIVE SHAFT ROTATIONS

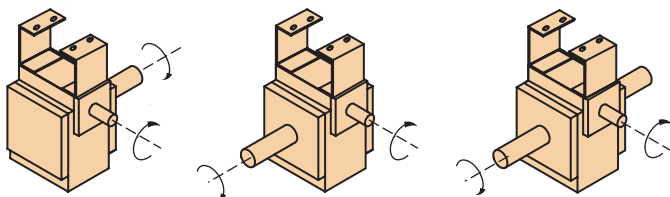

ASSEMBLY R

ASSEMBLY L

ASSEMBLY LR

The input shaft may be driven in either direction.



MDHS - CDHS Single Reduction Models

MDHS
Hanger
Quill Input Adaptor
Solid Output Shaft
Bracket Mount

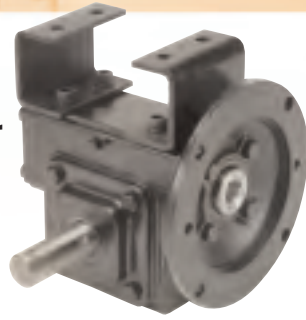

CDHS
Hanger
Coupled Input Adaptor
Solid Output Shaft
Bracket Mount



Couplings available, see page 106 for selection chart.

DIMENSIONS

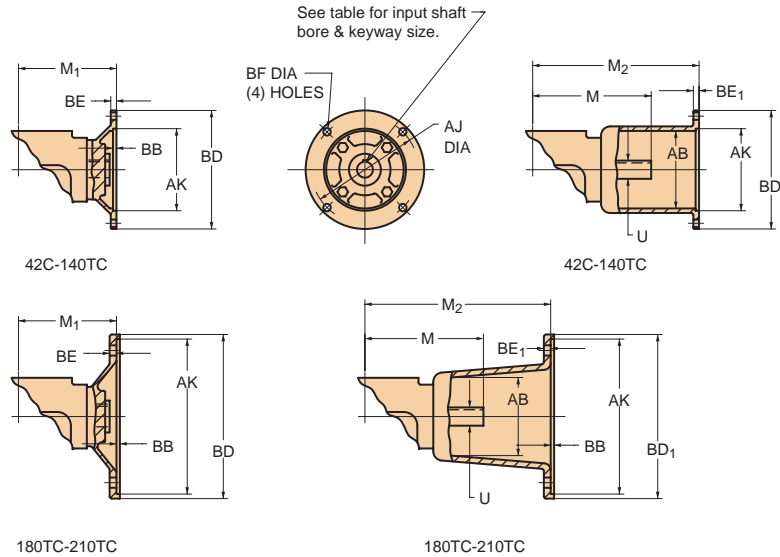

Size	QUILL INPUT ADAPTOR				COUPLED INPUT ADAPTOR														
	M ₁ 42C-48C	M ₁ 56C-140TC	M ₁ 180TC	M ₁ 210TC	42C-48C			56C-140TC			180TC			210TC			M	U	KEYWAY
					AB	M ₂	BE ₁	AB	M ₂	BE ₁	AB	M ₂	BE ₁	AB	M ₂	BE ₁			
E17	4.06	4.06	NA	NA	2.50	7.56	.38	NA			NA			NA			4.75	.750	3/16x3/32
E20	4.06	4.06	NA	NA	NA			NA			NA			NA			5.00	.750	3/16x3/32
E24	NA	5.38	5.38	NA	NA			4.13	9.13	.38	4.25	10.19	.50	NA			6.50	1.000	1/4x1/8
E26	NA	5.38	5.38	NA	NA			NA			NA			NA			6.50	1.000	1/4x1/8
E30	NA	5.56	5.56	NA	NA			4.13	9.75	.38	4.75	10.88	.50	4.75	10.88	.50	7.00	1.000	1/4x1/8
E35	NA	5.81	5.81	NA	NA			4.13	10.00	.38	4.75	11.13	.50	4.75	11.13	.50	7.38	1.000	1/4x1/8

AVAILABLE SHAFT ARRANGEMENTS AND RELATIVE SHAFT ROTATIONS

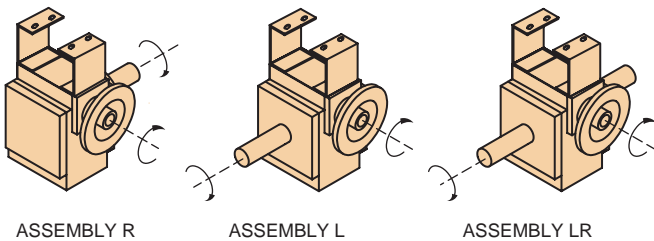

ASSEMBLY R

ASSEMBLY L

ASSEMBLY LR

The input shaft may be driven in either direction.

INPUT ADAPT. DIM.	42C 48C	56C	140TC	180TC	210TC
AJ	3.75	5.88	5.88	7.25	7.25
AK	3.00	4.50	4.50	8.50	8.50
BB	.19	.19	.19	.19	.19
BD	4.50	6.50	6.50	9.00	9.00
BD ₁	4.50	6.63	6.63	9.00	9.00
BE	.34	.31	.31	.38	.38
BF	.281	.406	.406	.531	.531
KEYWAY	1/8x1/16	3/16x3/32		1/4x1/8	5/16x5/32
BORE ^{+0.01} _{-.000}	.5005*	.6255	.8755	1.1255	1.3755

*42C adaptor has .3755 bore, 3/32x3/64 keyway



2D DRAWINGS & 3D MODELS
www.WINSMITH.com



XDVS Single Reduction Model



XDVS
Vertical
Solid Input Shaft
Solid Output Shaft
Flange Mount

SHIPPING WEIGHTS (lb.) ♦								
MODEL	E13	E17	E20	E24	E26	E30	E35	E43
XDVS	16	24	25	45	53	68	91	156
MDVS	19	26	28	49	54	73	97	161
CDVS	22	30	32	58	60	78	101	197

All motorized weights are for 48C to 140TC adaptor sizes. Add 10% for 180TC/210TC adaptor sizes.

♦Weights are approximate and include shipping carton.

DIMENSIONS

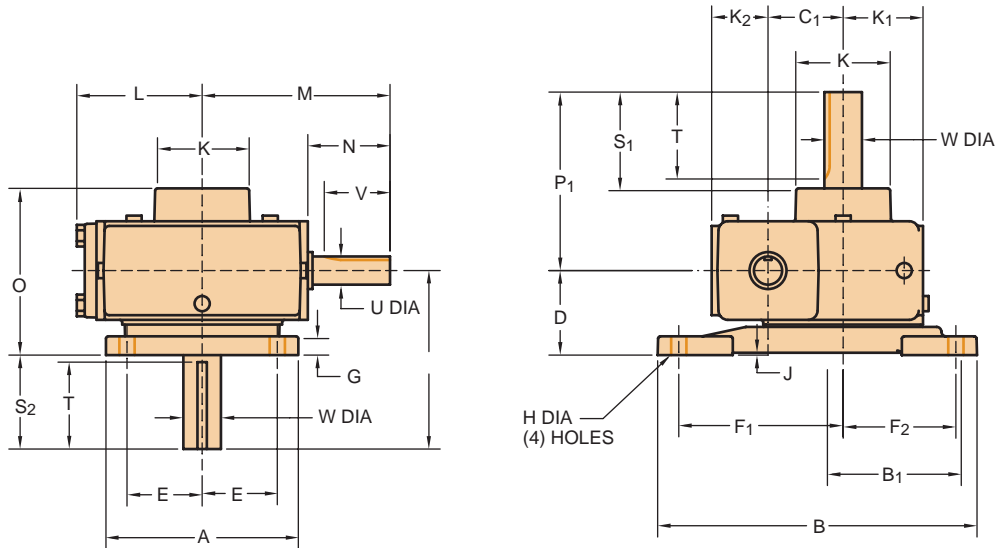

SPEED REDUCER DIMENSIONS (in.)

Size	A	B	B ₁	C ₁	D	E	F ₁	F ₂	G	H	J	K	K ₁	K ₂	L	M	O	P ₁	P ₂	INPUT SHAFT				OUTPUT SHAFT				
																				U*	N	V	KEYWAY	W*	S ₁	S ₂	T	KEYWAY
E13	4.25	6.60	2.69	1.333	2.25	1.75	3.53	2.31	.38	.281	.13	2.25	1.75	1.25	2.83	4.13	4.19	4.00	4.00	.625	1.81	1.63	3/16x3/32	.750	2.06	1.75	1.88	3/16x3/32
E17	5.13	7.75	3.19	1.750	2.25	2.00	4.00	2.63	.50	.406	.06	2.50	2.13	1.50	3.44	4.75	4.44	4.75	4.75	.750	1.94	1.69	3/16x3/32	1000	2.56	2.50	2.31	1/4x1/8
E20	5.13	8.50	3.56	2.000	2.25	2.00	4.38	3.00	.50	.406	.06	2.50	2.13	1.50	3.44	5.00	4.44	4.75	4.75	.750	2.19	1.75	3/16x3/32	1000	2.56	2.50	2.31	1/4x1/8
E24	6.88	8.88	3.44	2.375	3.50	2.88	4.88	2.88	.50	.406	.13	3.25	2.88	2.00	4.50	6.50	6.13	5.75	6.38	1.000	2.75	2.38	1/4x1/8	1250	3.12	2.88	2.75	1/4x1/8
E26	6.88	9.44	3.63	2.625	3.63	2.88	5.25	2.88	.50	.406	.13	3.50	3.13	2.13	4.50	6.50	6.26	5.63	6.38	1.000	2.75	2.38	1/4x1/8	1250	3.00	2.75	2.75	1/4x1/8
E30	8.88	10.63	4.25	3.000	3.75	3.81	5.75	3.63	.63	.563	.13	3.50	3.50	2.50	4.63	7.00	6.75	6.19	6.75	1.000	3.06	2.38	1/4x1/8	1375	3.19	3.00	3.06	5/16x5/32
E35	9.75	11.50	5.00	3.500	3.75	4.25	5.88	4.38	.63	.563	.13	4.13	4.00	2.63	5.06†	7.38	7.00	7.00	7.00	1.000	2.31	2.50	1/4x1/8	1750	3.75	3.25	3.63	3/8x3/16
E43	9.63	11.00	4.81	4.250	4.75	4.13	5.50	4.13	.63	.563	.13	4.75	4.38	2.88	5.88‡	8.19	8.38	8.00	8.00	1.250	2.31	2.50	1/4x1/8	2000	4.38	3.25	4.19	1/2x1/4

*Shaft diameter tolerances +.000-.001 Dimensions shown are for construction purposes only. Please contact Winsmith for certified dimension sheets.
† L dimension equals 5.46 on E35 MDVS model ‡ L dimension equals 6.28 on E43 MDVS model

AVAILABLE SHAFT ARRANGEMENTS AND RELATIVE SHAFT ROTATIONS

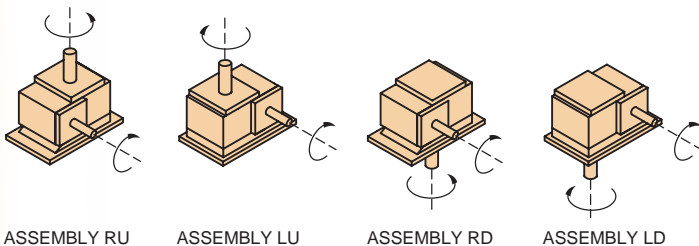

The input shaft may be driven in either direction.



Integral

MDVS - CDVS Single Reduction Models

MDVS
Vertical
Quill Input Adaptor
Solid Output Shaft
Flange Mount



CDVS
Vertical
Coupled Input Adaptor
Solid Output Shaft
Flange Mount



Couplings available, see page 106 for selection chart.

DIMENSIONS

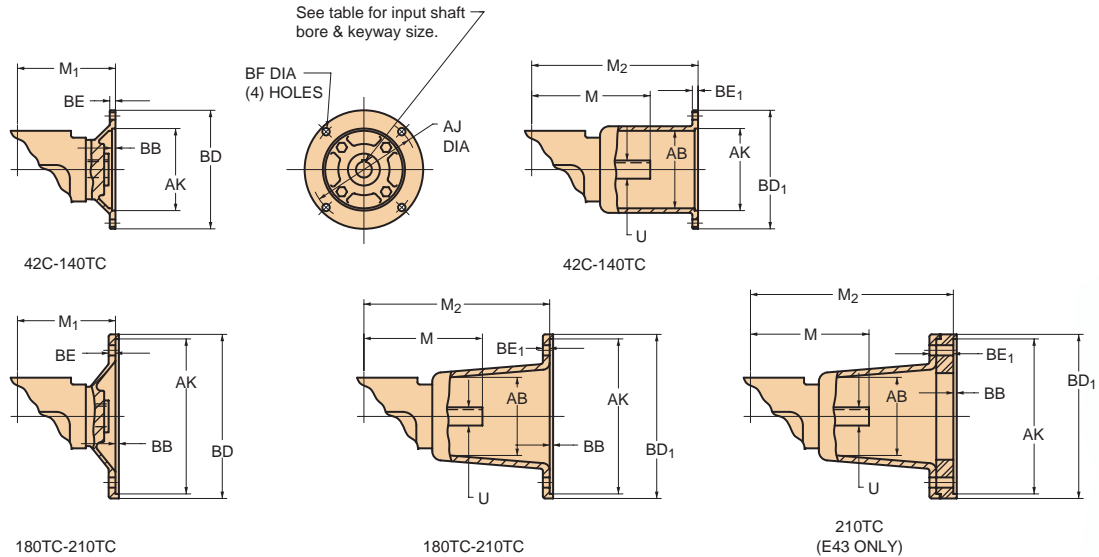

Size	QUILL INPUT ADAPTOR				COUPLED INPUT ADAPTOR														
	M ₁ 42C-48C	M ₁ 56C-140TC	M ₁ 180TC	M ₁ 210TC	42C-48C			56C-140TC			180TC			210TC			M	U	KEYWAY
	AB	M ₂	BE ₁	AB	M ₂	BE ₁	AB	M ₂	BE ₁	AB	M ₂	BE ₁							
E13	3.56	3.63*	NA	NA	2.50	6.81	.38	3.00	6.75	.31	NA			NA			4.13	.625	3/16x3/32
E17	4.06	4.06	NA	NA	2.50	7.56	.38	3.75	7.50	.38	3.75	8.44	.50	NA			4.75	.750	3/16x3/32
E20	4.06	4.06	NA	NA	2.50	7.56	.38	3.75	7.50	.38	3.75	8.44	.50	NA			5.00	.750	3/16x3/32
E24	NA	5.38	5.38	NA	NA			4.13	9.13	.38	4.25	10.19	.50	NA			6.50	1.000	1/4x1/8
E26	NA	5.38	5.38	NA	NA			4.13	9.13	.38	4.25	10.19	.50	NA			6.50	1.000	1/4x1/8
E30	NA	5.56	5.56	NA	NA			4.13	9.75	.38	4.75	10.88	.50	4.75	10.88	.50	7.00	1.000	1/4x1/8
E35	NA	5.81	5.81	NA	NA			4.13	10.00	.38	4.75	11.13	.50	4.75	11.13	.50	7.38	1.000	1/4x1/8
E43	NA	6.63	6.63	6.63	NA			4.13	10.81	.38	4.75	11.94	.50	4.75	12.88	1.44	8.19	1.250	1/4x1/8

*56C adaptor only

AVAILABLE SHAFT ARRANGEMENTS AND RELATIVE SHAFT ROTATIONS

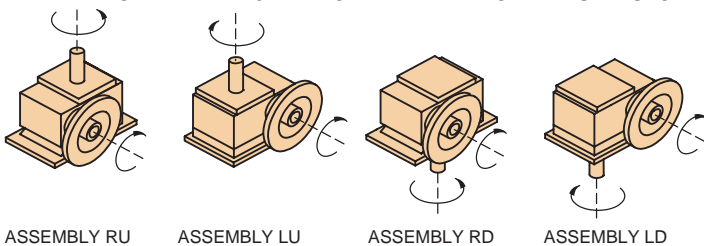

The input shaft may be driven in either direction.

INPUT ADAPT. DIM.	42C 48C	56C	140TC	180TC	210TC
AJ	3.75	5.88	5.88	7.25	7.25
AK	3.00	4.50	4.50	8.50	8.50
BB	.19	.19	.19	.19	.19
BD	4.50	6.50	6.50	9.00	9.00
BD ₁	4.50	6.63	6.63	9.00	9.00
BE	.34	.31	.31	.38	.38
BF	.281	.406	.406	.531	.531
KEYWAY	1/8 x 1/16	3/16 x 3/32		1/4 x 1/8	5/16 x 5/32
BORE $\begin{smallmatrix} +.001 \\ -.000 \end{smallmatrix}$.5005*	.6255	.8755	1.1255	1.3755

*42C adaptor has .3755 bore, 3/32 x 3/64 keyway



2D DRAWINGS & 3D MODELS
www.WINSMITH.com



XDLS Single Reduction Model



XDLS
Drop Bearing
Solid Input Shaft
Solid Output Shaft
Flange Mount

SHIPPING WEIGHTS (lb.) ♦				
MODEL	E26	E30	E35	E43
XDLS	53	93	126	179
MDLS	59	97	130	184
CDLS	62	103	136	189

All motorized weights are for 48C to 140TC adaptor sizes. Add 10% for 180TC/210TC adaptor sizes.

♦Weights are approximate and include shipping carton.

DIMENSIONS

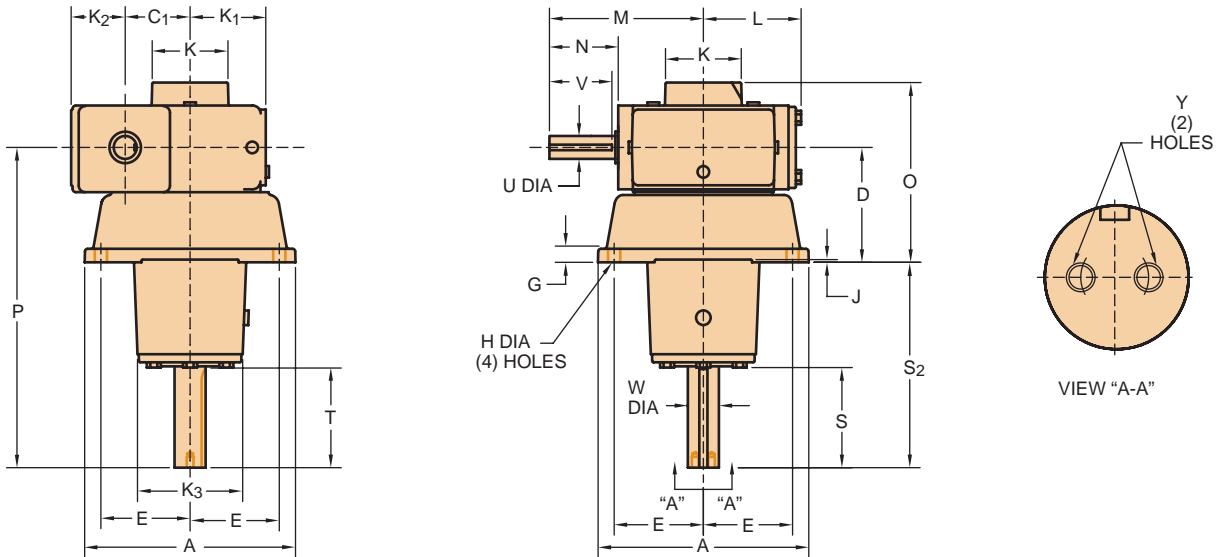

SPEED REDUCER DIMENSIONS (in.)

Size	A	C ₁	D	E	G	H	J	K	K ₁	K ₂	K ₃	L	M	O	P	Y DIMENSIONS			INPUT SHAFT			OUTPUT SHAFT					
																TAP	DEPTH	BOLT CIRCLE	U*	N	V	KEYWAY	W*	S	S ₂	T	KEYWAY
E26	9.00	2.625	4.44	4.00	.50	.406	.13	3.50	3.13	2.13	4.44	4.50	6.50	7.06	11.94	.25-20	.44	.625	1000	2.75	2.38	1/4x1/8	1250	3.68	7.50	3.50	1/4x1/8
E30	9.75	3.000	5.31	4.13	.63	.563	.13	3.50	3.50	2.50	5.19	4.63	7.00	8.31	14.81	.31-18	.50	.750	1000	3.06	2.38	1/4x1/8	1438	4.63	9.50	4.56	3/8x3/16
E35	12.00	3.500	5.38	5.25	.75	.563	.13	4.13	4.00	2.63	5.38	5.06†	7.38	8.63	14.88	.31-18	.50	.750	1000	2.31	2.50	1/4x1/8	1625	4.75	9.50	4.56	3/8x3/16
E43	14.00	4.250	6.00	6.00	.88	.688	.13	4.75	4.38	2.88	5.94	5.88†	8.19	9.63	16.50	.38-16	1.00	1.000	1250	2.31	2.50	1/4x1/8	1688	5.61	10.50	5.44	3/8x3/16

* Shaft diameter tolerances +.000 - .001 Dimensions shown are for construction purposes only. Please contact Winsmith for certified dimension sheets.

† L dimension equals 5.46 on E35 MDLS model ‡ L dimension equals 6.28 on E43 MDLS model

AVAILABLE SHAFT ARRANGEMENTS AND RELATIVE SHAFT ROTATIONS

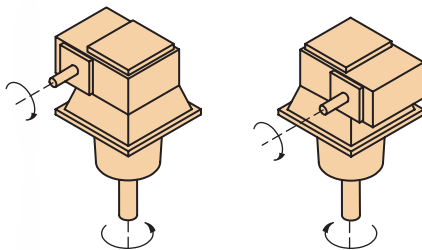

The input shaft may be driven in either direction.



MDLS - CDLS Single Reduction Models

MDLS
Drop Bearing
Quill Input Adaptor
Solid Output Shaft
Flange Mount



CDLS
Drop Bearing
Coupled Input Adaptor
Solid Output Shaft
Flange Mount



Couplings available, see page 106 for selection chart.

DIMENSIONS

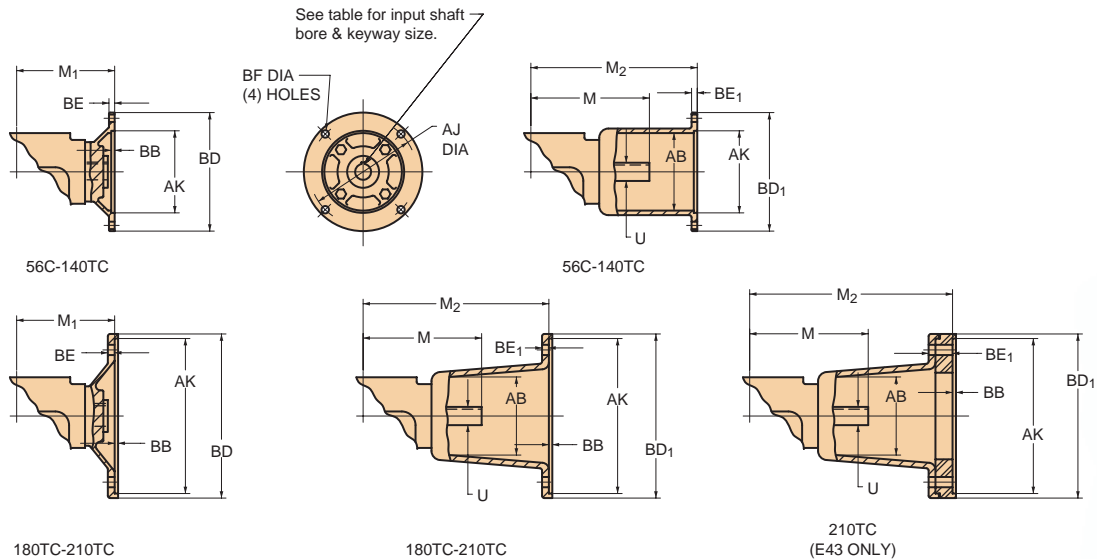

Size	QUILL INPUT ADAPTOR			COUPLED INPUT ADAPTOR											
	M ₁ 56C-140TC	M ₁ 180TC	M ₁ 210TC	56C-140TC			180TC			210TC*			M	U	KEYWAY
				AB	M ₂	BE ₁	AB	M ₂	BE ₁	AB	M ₂	BE ₁			
E26	5.38	5.38	NA	4.13	9.13	.38	4.25	10.19	.50	NA			6.50	1.000	1/4x1/8
E30	5.56	5.56	NA	4.13	9.75	.38	4.75	10.88	.50	4.75	10.88	.50	7.00	1.000	1/4x1/8
E35	5.81	5.81	NA	4.13	10.00	.38	4.75	11.13	.50	4.75	11.13	.50	7.38	1.000	1/4x1/8
E43	6.63	6.63	6.63	4.13	10.81	.38	4.75	11.94	.50	4.75	12.88	1.44	8.19	1.250	1/4x1/8

* Adaptor ring furnished with motor adaptor on size E43

AVAILABLE SHAFT ARRANGEMENTS AND RELATIVE SHAFT ROTATIONS

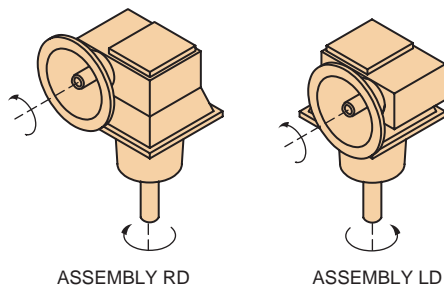

The input shaft may be driven in either direction.

INPUT ADAPT. DIM.	56C	140TC	180TC	210TC
AJ	5.88	5.88	7.25	7.25
AK	4.50	4.50	8.50	8.50
BB	.19	.19	.19	.19
BD	6.50	6.50	9.00	9.00
BD ₁	6.63	6.63	9.00	9.00
BE	.31	.31	.38	.38
BF	.406	.406	.531	.531
KEYWAY	3/16x3/32		1/4x1/8	5/16x5/32
BORE	^{+0.001} -.000	.6255	.8755	1.1255



2D DRAWINGS & 3D MODELS
www.WINSMITH.com



XDSS Single Reduction Model



SHIPPING WEIGHTS (lb.) ♦							
MODEL	E17	E20	E24	E26	E30	E35	E43
XDSS	23	27	43	48	61	86	174
MDSS	25	30	47	52	68	90	183
CDSS	32	35	56	61	80	93	192

All motorized weights are for 48C to 140TC adaptor sizes. Add 10% for 180TC/210TC adaptor sizes.

♦ Weights are approximate and include shipping carton.

XDSS
Universal
Solid Input Shaft
Hollow Output Shaft
Housing Mount

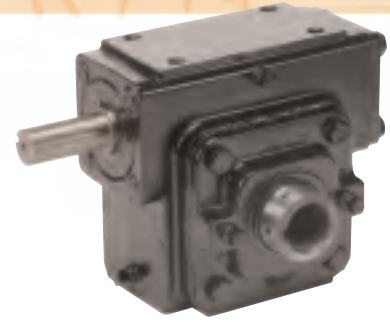

DIMENSIONS

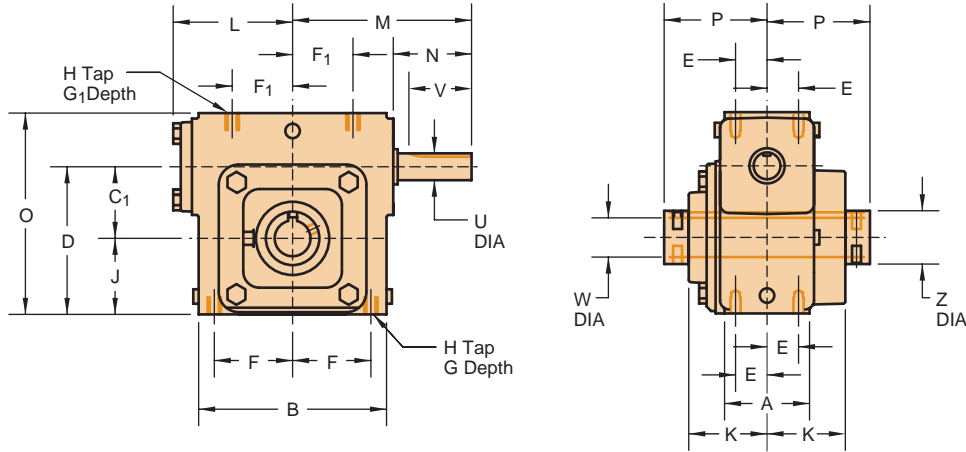

SPEED REDUCER DIMENSIONS (in.)

Size	A	B	C ₁	D	E	F	F ₁	G DEPTH	G ₁ DEPTH	H TAP	J	K	L	M	O	P	Z	INPUT SHAFT			
																		U*	N	V	KEYWAY
E17	2.38	4.63	1.750	3.88	.88	1.94	1.69	.62	.56	3/8-16	2.13	2.44	3.44	4.75	5.38	3.13	1.49	.750	1.94	1.69	3/16x3/32
E20	2.38	5.25	2.000	4.13	.88	2.19	1.69	.62	.56	3/8-16	2.13	2.63	3.44	5.00	5.63	3.31	2.00	.750	2.19	1.75	3/16x3/32
E24	3.13	5.38	2.375	5.25	1.13	2.19	2.19	.63	.57	1/2-13	2.88	2.75	4.50	6.50	7.25	3.44	2.25	1.000	2.75	2.38	1/4x1/8
E26	3.13	5.88	2.625	5.75	1.13	2.44	2.44	.69	.69	1/2-13	3.13	2.81	4.50	6.50	7.88	3.50	2.50	1.000	2.75	2.38	1/4x1/8
E30	3.50	6.62	3.000	6.50	1.31	2.75	2.75	.75	.75	1/2-13	3.50	3.00	4.63	7.00	9.00	3.69	2.63	1.000	3.06	2.38	1/4x1/8
E35	3.75	7.69	3.500	7.50	1.31	3.25	3.25	1.00	1.00	5/8-11	4.00	3.38	5.06†	7.38	10.13	4.13	2.87	1.000	2.31	2.50	1/4x1/8
E43	4.38	8.75	4.250	8.63	1.63	3.75	3.75	1.00	1.00	5/8-11	4.38	3.63	5.88‡	8.19	11.50	4.38	3.88	1.250	2.31	2.50	1/4x1/8

* Shaft diameter tolerances +.000 - .001 Dimensions shown are for construction purposes only. Please contact Winsmith for certified dimension sheets.

† L dimension equals 5.46 on E35 MDSS model ‡ L dimension equals 6.28 on E43 MDSS model

HOLLOW OUTPUT SHAFT BORES

(S) Standard Bore (M) Machined to Size Bore (B) Bushing*
 *Bushing for use with standard bore only

W**	KEYWAY	E17	E20	E24	E26	E30	E35	E43
.625	5/8	3/16x3/32	M/B					
.750	3/4	3/16x3/32	M/B	B				
.875	7/8	3/16x3/32	S	B				
1.000	1	1/4x1/8	S	M/B	M/B	B		
1.125	1-1/8	1/4x1/8	B	M/B	B			
1.188	1-3/16	1/4x1/8	M/B	B	B			
1.250	1-1/4	1/4x1/8	M/B	M/B	M/B	M/B	M/B	
1.375	1-3/8	5/16x5/32		B	B	B		
*1.438	1-7/16	3/8x3/16	S	M/B	B	B	M/B	
1.500	1-1/2	3/8x3/16		S	M/B	M/B	M/B	B
1.625	1-5/8	3/8x3/16						S
1.688	1-11/16	3/8x3/16			S	M/B	S	S
1.750	1-3/4	3/8x3/16			B	B	B	B
1.875	1-7/8	1/2x1/4			S	B	B	B
*1.938	1-15/16	1/2x1/4			S	M/B	M/B	M/B
2.000	2	1/2x1/4				M/B	S	
*2.188	2-3/16	1/2x1/4				S	M/B	M/B
2.250	2-1/4	1/2x1/4						B
2.438	2-7/16	5/8x5/16						M/B
2.500	2-1/2	5/8x5/16						B
2.750	2-3/4	5/8x5/16						S

AVAILABLE SHAFT ARRANGEMENTS AND RELATIVE SHAFT ROTATIONS

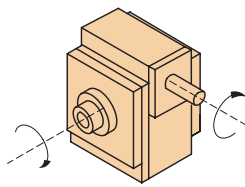

ASSEMBLY DLR

The input shaft may be driven in either direction.

** Bore tolerances +.000 +.002 Two puller slots opposed on all hollow output shafts

* Bore size 1.438 on size E20; keyway is 3/8x1/8. *Bore size 1.938 on size E30; keyway is 1/2x3/16

* Bore size 2.188 on size E35; keyway is 1/2x1/8. Contact Winsmith for other bore sizes



2D DRAWINGS & 3D MODELS
www.WINSMITH.com



Integral

MDSS - CDSS Single Reduction Models

MDSS
Universal
Quill Input Adaptor
Hollow Output Shaft
Housing Mount

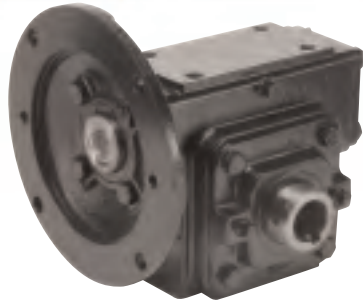

CDSS
Universal
Coupled Input Adaptor
Hollow Output Shaft
Housing Mount

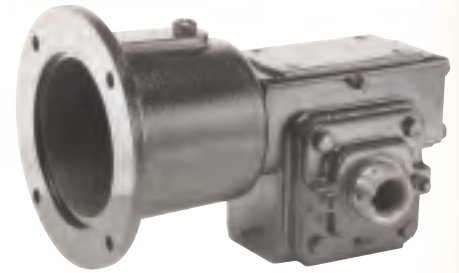

Couplings available, see page 106 for selection chart.

DIMENSIONS

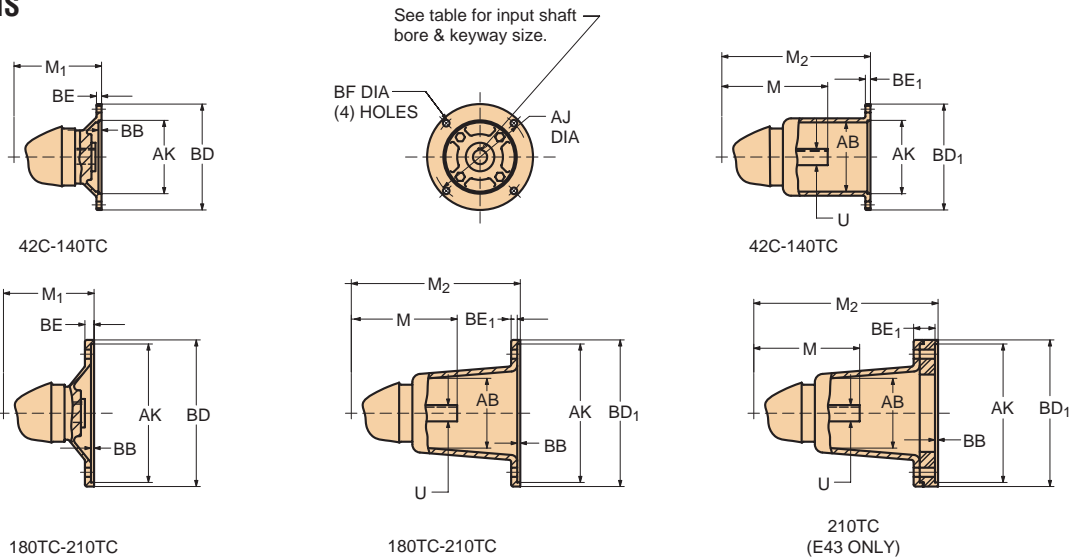

Size	QUILL INPUT ADAPTOR				COUPLED INPUT ADAPTOR											M	U	KEYWAY	
	M ₁ 42C-48C	M ₁ 56C-140TC	M ₁ 180TC	M ₁ 210TC	42C-48C			56C-140TC			180TC			210TC					
					AB	M ₂	BE ₁	AB	M ₂	BE ₁	AB	M ₂	BE ₁	AB	M ₂				BE ₁
E17	4.06	4.06	NA	NA	2.50	7.56	.38	3.75	7.50	.38	3.75	8.44	.50	NA			4.75	.750	3/16x3/32
E20	4.06	4.06	NA	NA	2.50	7.56	.38	3.75	7.50	.38	3.75	8.44	.50	NA			5.00	.750	3/16x3/32
E24	NA	5.38	5.38	NA	NA			4.13	9.13	.38	4.25	10.19	.50	NA			6.50	1.000	3/16x3/32
E26	NA	5.38	5.38	NA	NA			4.13	9.13	.38	4.25	10.19	.50	NA			6.50	1.000	1/4x1/8
E30	NA	5.56	5.56	NA	NA			4.13	9.75	.38	4.75	10.88	.50	4.75	10.88	.50	7.00	1.000	1/4x1/8
E35	NA	5.81	5.81	NA	NA			4.13	10.00	.38	4.75	11.13	.50	4.75	11.13	.50	7.38	1.000	1/4x1/8
E43	NA	6.63	6.63	6.63	NA			4.13	10.81	.38	4.75	11.94	.50	4.75	12.88	1.44	8.19	1.250	1/4x1/8

AVAILABLE SHAFT ARRANGEMENTS AND RELATIVE SHAFT ROTATIONS

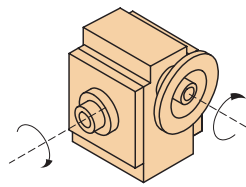

ASSEMBLY DLR

The input shaft may be driven in either direction.

INPUT ADAPT. DIM.	42C 48C	56C	140TC	180TC	210TC
AJ	3.75	5.88	5.88	7.25	7.25
AK	3.00	4.50	4.50	8.50	8.50
BB	.19	.19	.19	.19	.19
BD	4.50	6.50	6.50	9.00	9.00
BD ₁	4.50	6.63	6.63	9.00	9.00
BE	.34	.31	.31	.38	.38
BF	.281	.406	.406	.531	.531
KEYWAY	1/8 x 1/16	3/16 x 3/32		1/4 x 1/8	5/16 x 5/32
BORE +.001 -.000	.5005*	.6255	.8755	1.1255	1.3755

*42C adaptor has .3755 bore, 3/32 x 3/64 keyway



2D DRAWINGS & 3D MODELS
www.WINSMITH.com



XSTS Single Reduction Model

WINSMITH

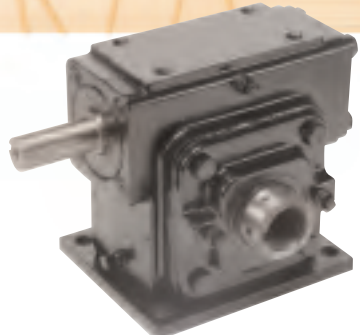

XSTS
Worm-On-Top
Solid Input Shaft
Hollow Output Shaft
Base Mount

SHIPPING WEIGHTS (lb.) ♦							
MODEL	E17	E20	E24	E26	E30	E35	E43
XSTS	27	31	48	54	69	96	188
MSTS	29	34	52	58	76	100	197
CSTS	35	39	61	67	88	103	206

All motorized weights are for 48C to 140TC adaptor sizes. Add 10% for 180TC/210TC adaptor sizes.

♦ Weights are approximate and include shipping carton.

DIMENSIONS

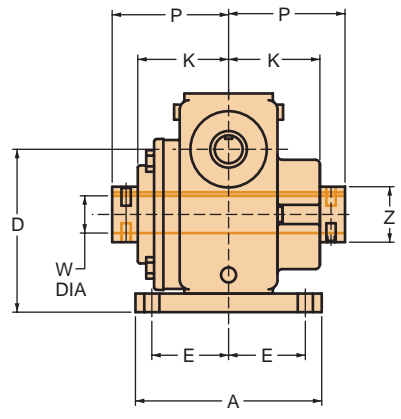
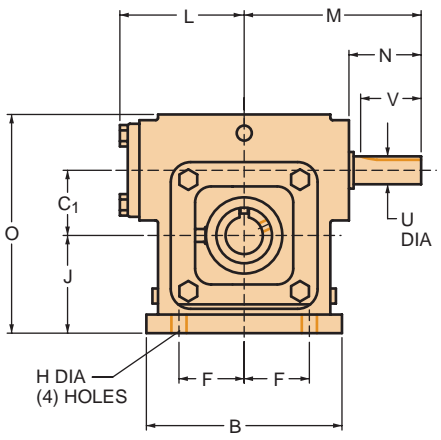

SPEED REDUCER DIMENSIONS (in.)

Size	A	B	C ₁	D	E	F	G	H	J	K	L	M	O	P	Z	INPUT SHAFT			
																U*	N	V	KEYWAY
E17	4.50	5.50	1.750	4.19	1.75	2.31	.31	.406	2.44	2.44	3.44	4.75	5.69	3.13	1.49	.750	1.94	1.69	3/16x3/32
E20	4.50	5.88	2.000	4.63	1.88	2.50	.50	.406	2.63	2.63	3.44	5.00	6.13	3.31	2.00	.750	2.19	1.75	3/16x3/32
E24	4.50	7.00	2.375	5.63	1.88	3.13	.38	.406	3.25	2.75	4.50	6.50	7.63	3.44	2.25	1.000	2.75	2.38	1/4x1/8
E26	4.50	7.50	2.625	6.13	1.88	3.25	.38	.406	3.50	2.81	4.50	6.50	8.25	3.50	2.50	1.000	2.75	2.38	1/4x1/8
E30	6.00	8.00	3.000	7.00	2.38	3.50	.50	.563	4.00	3.00	4.63	7.00	9.50	3.69	2.63	1.000	3.06	2.38	1/4x1/8
E35	6.50	10.00	3.500	8.00	2.63	4.13	.50	.563	4.50	3.38	5.06†	7.38	10.63	4.13	2.87	1.000	2.31	2.50	1/4x1/8
E43	7.00	11.00	4.250	9.25	2.88	4.88	.63	.563	5.00	3.63	5.88‡	8.19	12.13	4.38	3.88	1.250	2.31	2.50	1/4x1/8

* Shaft diameter tolerances +.000 -.001 Dimensions shown are for construction purposes only. Please contact Winsmith for certified dimension sheets.
 † L dimension equals 5.46 on E35 MSTS model ‡ L dimension equals 6.28 on E43 MSTS model

AVAILABLE SHAFT ARRANGEMENTS AND RELATIVE SHAFT ROTATIONS

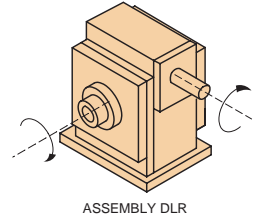

The input shaft may be driven in either direction.

HOLLOW OUTPUT SHAFT BORES

(S) Standard Bore (M) Machined to Size Bore (B) Bushing*
 *Bushing for use with standard bore only

W**	KEYWAY	E17	E20	E24	E26	E30	E35	E43
.625	5/8	3/16x3/32	M/B					
.750	3/4	3/16x3/32	M/B	B				
.875	7/8	3/16x3/32	S	B				
1.000	1	1/4x1/8	S	M/B	M/B	B		
1.125	1-1/8	1/4x1/8	B	M/B	B			
1.188	1-3/16	1/4x1/8	M/B	B	B			
1.250	1-1/4	1/4x1/8	M/B	M/B	M/B	M/B	M/B	
1.375	1-3/8	5/16x5/32		B	B	B		
*1.438	1-7/16	3/8x3/16	S	M/B	B	B	M/B	
1.500	1-1/2	3/8x3/16		S	M/B	M/B	M/B	B
1.625	1-5/8	3/8x3/16						S
1.688	1-11/16	3/8x3/16			S	M/B	S	S
1.750	1-3/4	3/8x3/16				B	B	B
1.875	1-7/8	1/2x1/4					S	B
*1.938	1-15/16	1/2x1/4				S	M/B	M/B
2.000	2	1/2x1/4					M/B	S
*2.188	2-3/16	1/2x1/4					S	M/B
2.250	2-1/4	1/2x1/4						B
2.438	2-7/16	5/8x5/16						M/B
2.500	2-1/2	5/8x5/16						B
2.750	2-3/4	5/8x5/16						S

** Bore tolerances +.000 +.002 Two puller slots opposed on all hollow output shafts
 * Bore size 1.438 on size E20: keyway is 3/8x1/8. * Bore size 1.938 on size E30: keyway is 1/2x3/16
 * Bore size 2.188 on size E35: keyway is 1/2x1/8. Contact Winsmith for other bore sizes



Integral

MSTS - CSTS Single Reduction Models

MSTS
Worm-On-Top
Quill Input Adaptor
Hollow Output Shaft
Base Mount

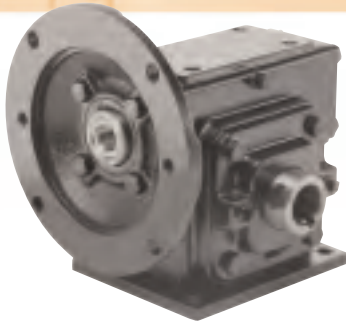

CSTS
Worm-On-Top
Coupled Input Adaptor
Hollow Output Shaft
Base Mount

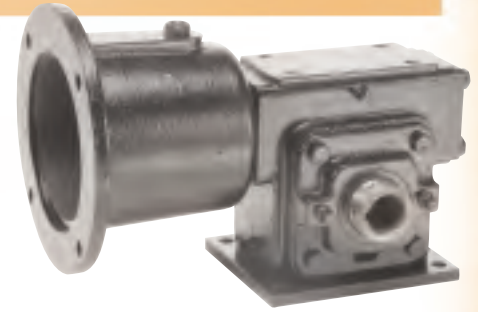

Couplings available, see page 106 for selection chart.

DIMENSIONS

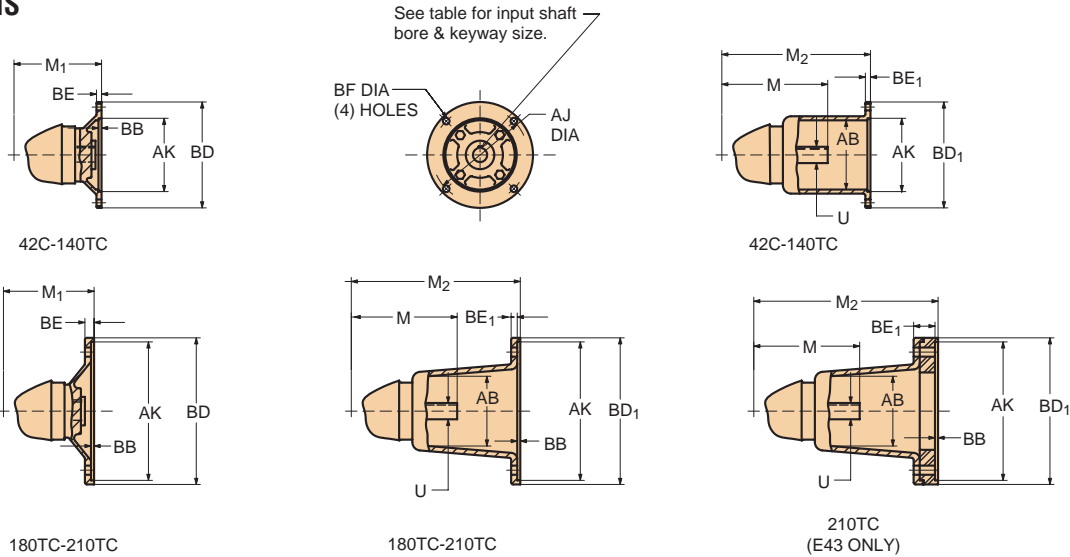

Size	QUILL INPUT ADAPTOR				COUPLED INPUT ADAPTOR														
	M ₁ 42C-48C	M ₁ 56C-140TC	M ₁ 180TC	M ₁ 210TC	42C-48C			56C-140TC			180TC			210TC		M	U	KEYWAY	
	AB	M ₂	BE ₁	AB	M ₂	BE ₁	AB	M ₂	BE ₁	AB	M ₂	BE ₁	AB	M ₂	BE ₁				
E17	4.06	4.06	NA	NA	2.50	7.56	.38	3.75	7.50	.38	3.75	8.44	.50	NA		4.75	.750	3/16x3/32	
E20	4.06	4.06	NA	NA	2.50	7.56	.38	3.75	7.50	.38	3.75	8.44	.50	NA		5.00	.750	3/16x3/32	
E24	NA	5.38	5.38	NA	NA			4.13	9.13	.38	4.25	10.19	.50	NA		6.50	1.000	3/16x3/32	
E26	NA	5.38	5.38	NA	NA			4.13	9.13	.38	4.25	10.19	.50	NA		6.50	1.000	1/4x1/8	
E30	NA	5.56	5.56	NA	NA			4.13	9.75	.38	4.75	10.88	.50	4.75	10.88	.50	7.00	1.000	1/4x1/8
E35	NA	5.81	5.81	NA	NA			4.13	10.00	.38	4.75	11.13	.50	4.75	11.13	.50	7.38	1.000	1/4x1/8
E43	NA	6.63	6.63	6.63	NA			4.13	10.81	.38	4.75	11.94	.50	4.75	12.88	1.44	8.19	1.250	1/4x1/8

AVAILABLE SHAFT ARRANGEMENTS AND RELATIVE SHAFT ROTATIONS

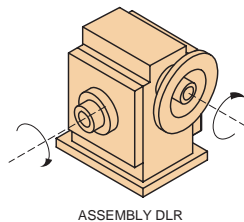

The input shaft may be driven in either direction.

INPUT ADAPT. DIM.	42C 48C	56C	140TC	180TC	210TC
AJ	3.75	5.88	5.88	7.25	7.25
AK	3.00	4.50	4.50	8.50	8.50
BB	.19	.19	.19	.19	.19
BD	4.50	6.50	6.50	9.00	9.00
BD ₁	4.50	6.63	6.63	9.00	9.00
BE	.34	.31	.31	.38	.38
BF	.281	.406	.406	.531	.531
KEYWAY	1/8 x 1/16	3/16 x 3/32		1/4 x 1/8	5/16 x 5/32
BORE ^{+0.01} / _{-.000}	.5005*	.6255	.8755	1.1255	1.3755

* 42C adaptor has .3755 bore, 3/32 x 3/64 keyway



2D DRAWINGS & 3D MODELS
www.WINSMITH.com



XSBS Single Reduction Model



SHIPPING WEIGHTS (lb.) ♦							
MODEL	E17	E20	E24	E26	E30	E35	E43
XSBS	27	32	44	49	63	88	193
MSBS	29	35	48	53	70	92	197
CSBS	36	40	57	62	82	95	199

All motorized weights are for 48C to 140TC adaptor sizes. Add 10% for 180TC/210TC adaptor sizes.

♦ Weights are approximate and include shipping carton.

XSBS
Worm-On-Bottom
Solid Input Shaft
Hollow Output Shaft
Base Mount

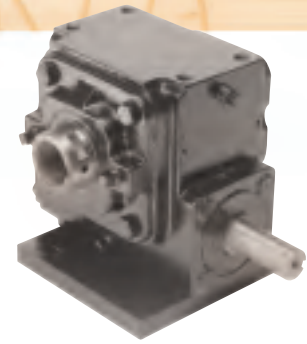

DIMENSIONS

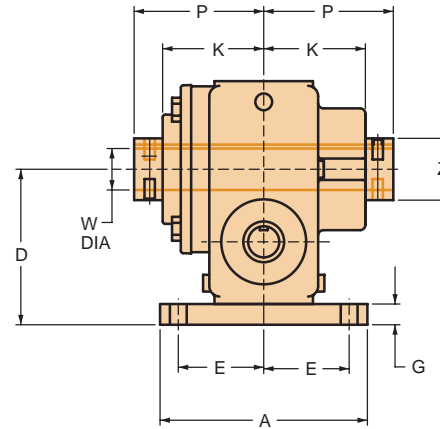
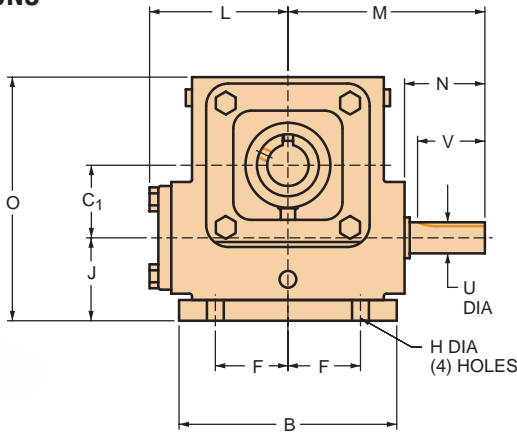

SPEED REDUCER DIMENSIONS (in.)

Size	A	B	C ₁	D	E	F	G	H	J	K	L	M	O	P	Z	INPUT SHAFT			
																U*	N	V	KEYWAY
E17	5.00	4.63	1.750	3.75	2.06	1.44	.50	.406	2.00	2.44	3.44	4.75	5.88	3.13	1.49	.750	1.94	1.69	3/16x3/32
E20	5.00	4.63	2.000	4.00	2.06	1.44	.50	.406	2.00	2.63	3.44	5.00	6.13	3.31	2.00	.750	2.19	1.75	3/16x3/32
E24	5.00	7.00	2.375	4.75	2.00	3.00	.38	.406	2.38	2.75	4.50	6.50	7.63	3.44	2.25	1.000	2.75	2.38	1/4x1/8
E26	4.75	7.00	2.625	5.13	2.00	3.00	.38	.406	2.50	2.81	4.50	6.50	8.25	3.50	2.50	1.000	2.75	2.38	1/4x1/8
E30	6.00	8.00	3.000	6.00	2.38	3.50	.50	.563	3.00	3.00	4.63	7.00	9.50	3.69	2.63	1.000	3.06	2.38	1/4x1/8
E35	6.50	10.00	3.500	6.63	2.63	4.13	.50	.563	3.13	3.38	5.06†	7.38	10.63	4.13	2.87	1.000	2.31	2.50	1/4x1/8
E43	7.00	11.00	4.250	7.75	2.88	4.88	.63	.563	3.50	3.63	5.88‡	8.19	12.13	4.38	3.88	1.250	2.31	2.50	1/4x1/8

* Shaft diameter tolerances +.000 - .001 Dimensions shown are for construction purposes only. Please contact Winsmith for certified dimension sheets.

† L dimension equals 5.46 on E35 MSBS model ‡ L dimension equals 6.28 on E43 MSBS model

HOLLOW OUTPUT SHAFT BORES

(S) Standard Bore (M) Machined to Size Bore (B) Bushing*
*Bushing for use with standard bore only

W**	KEYWAY	E17	E20	E24	E26	E30	E35	E43
.625	5/8	3/16x3/32	M/B					
.750	3/4	3/16x3/32	M/B	B				
.875	7/8	3/16x3/32	S	B				
1.000	1	1/4x1/8	S	M/B	M/B	B		
1.125	1-1/8	1/4x1/8		B	M/B	B		
1.188	1-3/16	1/4x1/8		M/B	B	B		
1.250	1-1/4	1/4x1/8		M/B	M/B	M/B	M/B	
1.375	1-3/8	5/16x5/32			B	B	B	
*1.438	1-7/16	3/8x3/16		S	M/B	B	B	M/B
1.500	1-1/2	3/8x3/16			S	M/B	M/B	M/B
1.625	1-5/8	3/8x3/16						S
1.688	1-11/16	3/8x3/16				S	M/B	S
1.750	1-3/4	3/8x3/16				B	B	B
1.875	1-7/8	1/2x1/4						S
*1.938	1-15/16	1/2x1/4				S	M/B	M/B
2.000	2	1/2x1/4					M/B	S
*2.188	2-3/16	1/2x1/4					S	M/B
2.250	2-1/4	1/2x1/4						B
2.438	2-7/16	5/8x5/16						M/B
2.500	2-1/2	5/8x5/16						B
2.750	2-3/4	5/8x5/16						S

** Bore tolerances +.000 +.002 Two puller slots opposed on all hollow output shafts
* Bore size 1.438 on size E20; keyway is 3/8x1/8. * Bore size 1.938 on size E30; keyway is 1/2x3/16
* Bore size 2.188 on size E35; keyway is 1/2x1/8. Contact Winsmith for other bore sizes

AVAILABLE SHAFT ARRANGEMENTS AND RELATIVE SHAFT ROTATIONS

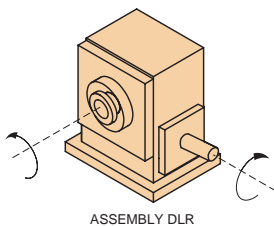

ASSEMBLY DLR

The input shaft may be driven in either direction.



Integral

MSBS - CSBS Single Reduction Models

MSBS
Worm-On-Bottom
Quill Input Adaptor
Hollow Output Shaft
Base Mount

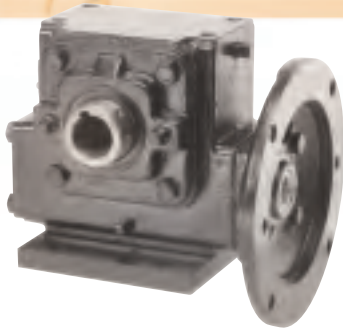

CSBS
Worm-On-Bottom
Coupled Input Adaptor
Hollow Output Shaft
Base Mount

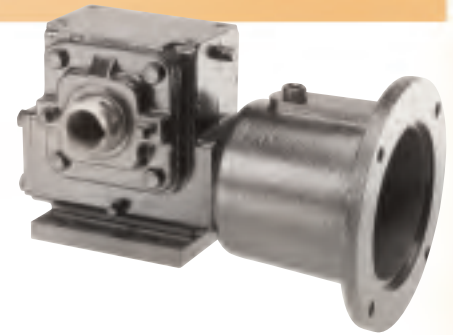

Couplings available, see page 106 for selection chart.

DIMENSIONS

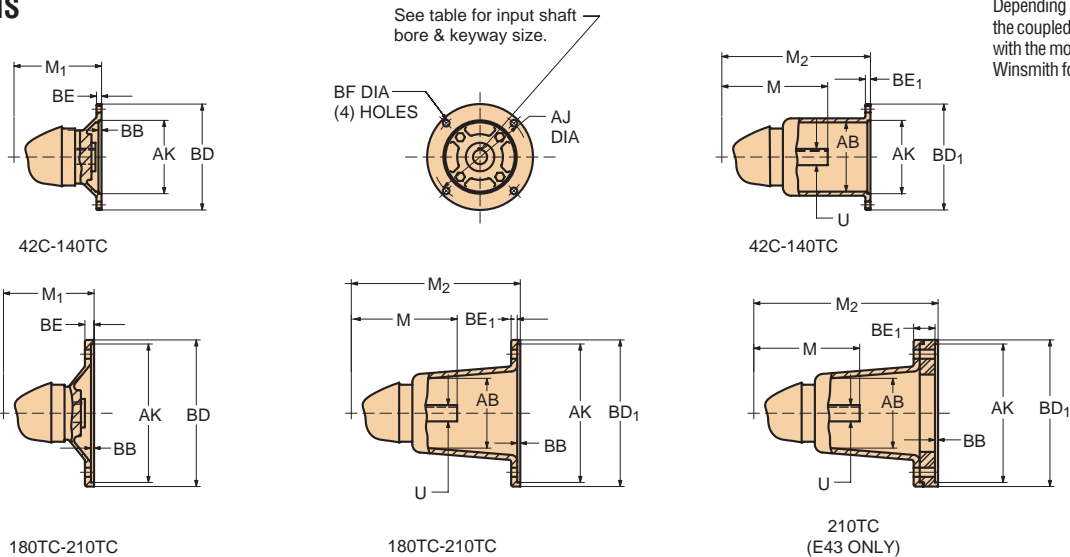

Depending on size and base selection, the coupled input adaptor may interfere with the mounting base. Please contact Winsmith for assistance.

Size	QUILL INPUT ADAPTOR				COUPLED INPUT ADAPTOR											M	U	KEYWAY	
	M ₁ 42C-48C	M ₁ 56C-140TC	M ₁ 180TC	M ₁ 210TC	42C-48C			56C-140TC			180TC			210TC					
	AB	M ₂	BE ₁	AB	M ₂	BE ₁	AB	M ₂	BE ₁	AB	M ₂	BE ₁	AB	M ₂	BE ₁				
E17	4.06	4.06	NA	NA	2.50	7.56	.38	3.75	7.50	.38	3.75	8.44	.50	NA			4.75	.750	3/16x3/32
E20	4.06	4.06	NA	NA	2.50	7.56	.38	3.75	7.50	.38	3.75	8.44	.50	NA			5.00	.750	3/16x3/32
E24	NA	5.38	5.38	NA	NA			4.13	9.13	.38	4.25	10.19	.50	NA			6.50	1.000	3/16x3/32
E26	NA	5.38	5.38	NA	NA			4.13	9.13	.38	4.25	10.19	.50	NA			6.50	1.000	1/4x1/8
E30	NA	5.56	5.56	NA	NA			4.13	9.75	.38	4.75	10.88	.50	4.75	10.88	.50	7.00	1.000	1/4x1/8
E35	NA	5.81	5.81	NA	NA			4.13	10.00	.38	4.75	11.13	.50	4.75	11.13	.50	7.38	1.000	1/4x1/8
E43	NA	6.63	6.63	6.63	NA			4.13	10.81	.38	4.75	11.94	.50	4.75	12.88	1.44	8.19	1.250	1/4x1/8

AVAILABLE SHAFT ARRANGEMENTS AND RELATIVE SHAFT ROTATIONS

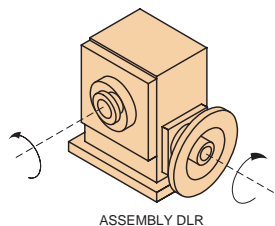

The input shaft may be driven in either direction.

INPUT ADAPT. DIM.	42C 48C	56C	140TC	180TC	210TC
AJ	3.75	5.88	5.88	7.25	7.25
AK	3.00	4.50	4.50	8.50	8.50
BB	.19	.19	.19	.19	.19
BD	4.50	6.50	6.50	9.00	9.00
BD ₁	4.50	6.63	6.63	9.00	9.00
BE	.34	.31	.31	.38	.38
BF	.281	.406	.406	.531	.531
KEYWAY	1/8 x 1/16	3/16 x 3/32		1/4 x 1/8	5/16 x 5/32
BORE $\begin{matrix} +.001 \\ -.000 \end{matrix}$.5005*	.6255	.8755	1.1255	1.3755

* 42C adaptor has .3755 bore, 3/32x3/64 keyway



2D DRAWINGS & 3D MODELS
www.WINSMITH.com



XSJS Single Reduction Model



XSJS
"J" Vertical
Solid Input Shaft
Hollow Output Shaft
Bracket Mount

SHIPPING WEIGHTS (lb.) ♦							
MODEL	E17	E20	E24	E26	E30	E35	E43
XSJS	26	32	49	54	69	95	182
MSJS	28	35	53	58	76	99	194
CSJS	35	40	62	67	88	102	203

All motorized weights are for 48C to 140TC adaptor sizes. Add 10% for 180TC/210TC adaptor sizes.

♦Weights are approximate and include shipping carton.

DIMENSIONS

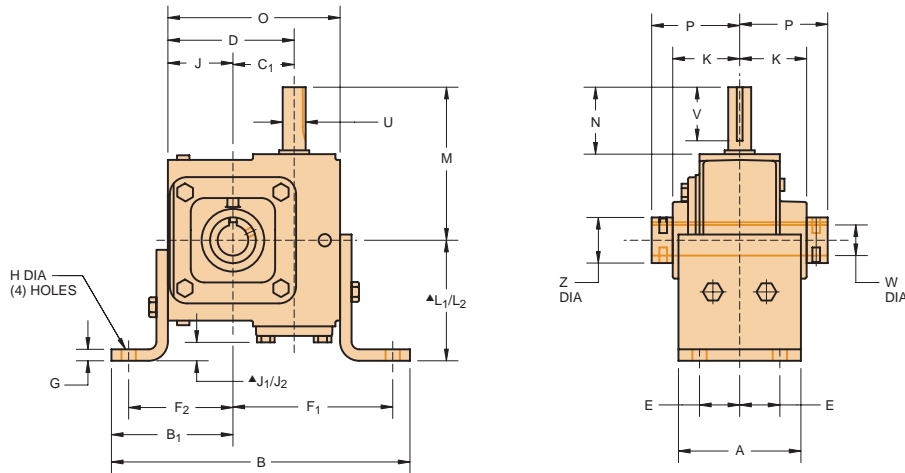

SPEED REDUCER DIMENSIONS (in.)

Size	A	B	B ₁	C ₁	D	E	F ₁	F ₂	G	H _{DIA}	J ₁	J ₂ [*]	K	L ₁	L ₂ [*]	M	O	P	Z	INPUT SHAFT			
																				U [*]	N	V	KEYWAY
E17	3.50	8.63	3.50	1.750	3.88	1.25	4.63	3.00	.25	.406	.06	1.35	2.44	3.50	4.79	4.75	5.38	3.13	1.49	.750	1.94	1.69	3/16x3/32
E20	4.00	9.75	3.97	2.000	4.13	1.31	5.22	3.41	.38	.469	.50	1.88	2.63	3.94	5.32	5.00	5.63	3.31	2.00	.750	2.19	1.75	3/16x3/32
E24	4.00	10.75	4.63	2.375	5.25	1.44	5.56	4.06	.38	.469	.13	2.00	2.75	4.63	6.50	6.50	7.25	3.44	2.25	1.000	2.75	2.38	1/4x1/8
E26	4.50	11.63	4.75	2.625	5.75	1.56	6.25	4.13	.38	.531	.25	2.00	2.81	4.75	6.50	6.50	7.88	3.50	2.50	1.000	2.75	2.38	1/4x1/8
E30	5.50	12.50	5.25	3.000	6.50	2.00	6.63	4.63	.38	.531	.12	2.38	3.00	4.75	7.00	7.00	9.00	3.69	2.63	1.000	3.06	2.38	1/4x1/8
E35	5.50	14.50	6.19	3.500	7.50	2.00	7.56	5.19	.38	.531	.23	2.67	3.38	5.69	8.13	7.38	10.13	4.13	2.87	1.000	2.31	2.50	1/4x1/8
E43	6.50	15.88	6.56	4.250	8.63	2.50	8.56	5.81	.38	.656	.22	2.60	3.63	6.50	8.88	8.19	11.50	4.38	3.88	1.250	2.31	2.50	1/4x1/8

* Shaft diameter tolerances +.000 -.001 Dimensions shown are for construction purposes only.

†G₂ Dimension equals .23 on E35 MSJS model and .22 on E43 MSJS model

* J₂ and L₂ dimension apply when using top two mounting holes on bracket

Please contact Winsmith for certified dimension sheets.

AVAILABLE SHAFT ARRANGEMENTS AND RELATIVE SHAFT ROTATIONS

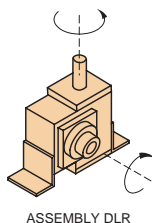

ASSEMBLY DLR

The input shaft may be driven in either direction.

HOLLOW OUTPUT SHAFT BORES

(S) Standard Bore (M) Machined to Size Bore (B) Bushing
 *Bushing for use with standard bore only

W**	KEYWAY	E17	E20	E24	E26	E30	E35	E43
.625	5/8	3/16x3/32	M/B					
.750	3/4	3/16x3/32	M/B	B				
.875	7/8	3/16x3/32	S	B				
1.000	1	1/4x1/8	S	M/B	M/B	B		
1.125	1-1/8	1/4x1/8	B	M/B	B			
1.188	1-3/16	1/4x1/8	M/B	B	B			
1.250	1-1/4	1/4x1/8	M/B	M/B	M/B	M/B	M/B	
1.375	1-3/8	5/16x5/32		B	B	B		
*1.438	1-7/16	3/8x3/16		S	M/B	B	B	M/B
1.500	1-1/2	3/8x3/16			S	M/B	M/B	M/B
1.625	1-5/8	3/8x3/16						S
1.688	1-11/16	3/8x3/16				S	M/B	S
1.750	1-3/4	3/8x3/16				B	B	B
1.875	1-7/8	1/2x1/4					S	B
*1.938	1-15/16	1/2x1/4				S	M/B	M/B
2.000	2	1/2x1/4					M/B	S
*2.188	2-3/16	1/2x1/4					S	M/B
2.250	2-1/4	1/2x1/4						B
2.438	2-7/16	5/8x5/16						M/B
2.500	2-1/2	5/8x5/16						B
2.750	2-3/4	5/8x5/16						S

** Bore tolerances +.000 +.002 Two puller slots opposed on all hollow output shafts

* Bore size 1.438 on size E20: keyway is 3/8x1/8. *Bore size 1.938 on size E30: keyway is 1/2x3/16

* Bore size 2.188 on size E35: keyway is 1/2x1/8. Contact Winsmith for other bore sizes



Integral

MSJS - CSJS Single Reduction Models

MSJS
 "J" Vertical
 Quill Input Adaptor
 Hollow Output Shaft
 Bracket Mount



CSJS
 "J" Vertical
 Coupled Input Adaptor
 Hollow Output Shaft
 Bracket Mount



Couplings available, see page 106 for selection chart.

DIMENSIONS

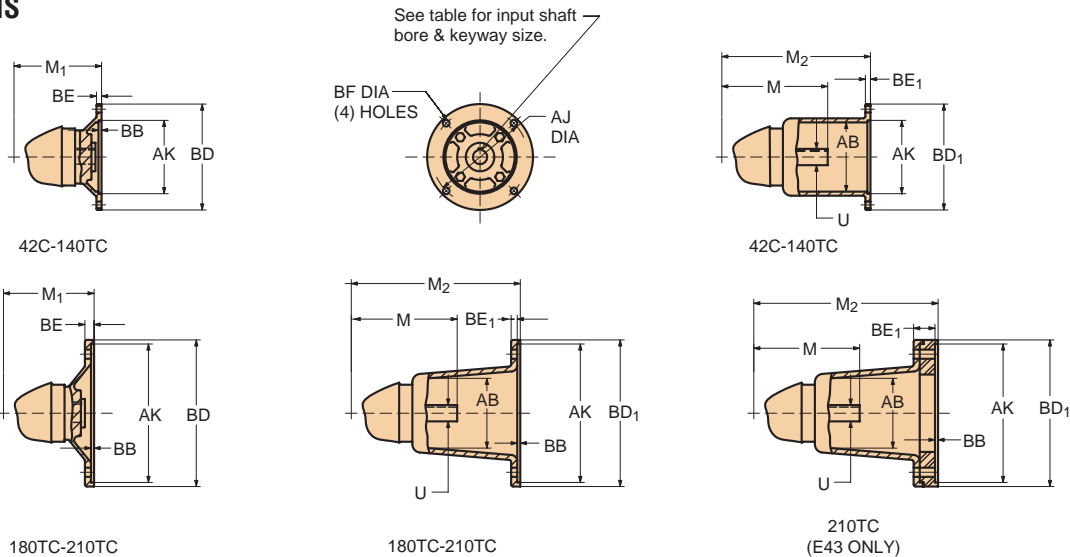

Size	QUILL INPUT ADAPTOR				COUPLED INPUT ADAPTOR											M	U	KEYWAY	
	M ₁ 42C-48C	M ₁ 56C-140TC	M ₁ 180TC	M ₁ 210TC	42C-48C			56C-140TC			180TC			210TC					
	AB	M ₂	BE ₁	AB	M ₂	BE ₁	AB	M ₂	BE ₁	AB	M ₂	BE ₁	AB	M ₂	BE ₁				
E17	4.06	4.06	NA	NA	2.50	7.56	.38	3.75	7.50	.38	3.75	8.44	.50	NA			4.75	.750	3/16 x 3/32
E20	4.06	4.06	NA	NA	2.50	7.56	.38	3.75	7.50	.38	3.75	8.44	.50	NA			5.00	.750	3/16 x 3/32
E24	NA	5.38	5.38	NA	NA			4.13	9.13	.38	4.25	10.19	.50	NA			6.50	1.000	3/16 x 3/32
E26	NA	5.38	5.38	NA	NA			4.13	9.13	.38	4.25	10.19	.50	NA			6.50	1.000	1/4 x 1/8
E30	NA	5.56	5.56	NA	NA			4.13	9.75	.38	4.75	10.88	.50	4.75	10.88	.50	7.00	1.000	1/4 x 1/8
E35	NA	5.81	5.81	NA	NA			4.13	10.00	.38	4.75	11.13	.50	4.75	11.13	.50	7.38	1.000	1/4 x 1/8
E43	NA	6.63	6.63	6.63	NA			4.13	10.81	.38	4.75	11.94	.50	4.75	12.88	1.44	8.19	1.250	1/4 x 1/8

AVAILABLE SHAFT ARRANGEMENTS AND RELATIVE SHAFT ROTATIONS

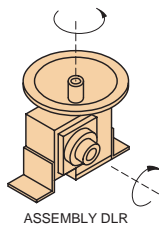

The input shaft may be driven in either direction.

INPUT ADAPT. DIM.	42C 48C	56C	140TC	180TC	210TC
AJ	3.75	5.88	5.88	7.25	7.25
AK	3.00	4.50	4.50	8.50	8.50
BB	.19	.19	.19	.19	.19
BD	4.50	6.50	6.50	9.00	9.00
BD ₁	4.50	6.63	6.63	9.00	9.00
BE	.34	.31	.31	.38	.38
BF	.281	.406	.406	.531	.531
KEYWAY	1/8 x 1/16	3/16 x 3/32		1/4 x 1/8	5/16 x 5/32
BORE $^{+.001}_{-.000}$.5005*	.6255	.8755	1.1255	1.3755

*42C adaptor has .3755 bore, 3/32 x 3/64 keyway



2D DRAWINGS & 3D MODELS
 www.WINSMITH.com



XSUS Single Reduction Model

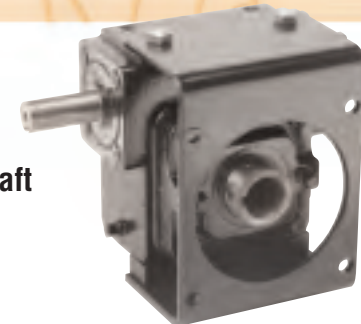

XSUS
 "U" Flange
 Solid Input Shaft
 Hollow Output Shaft
 Bracket Mount

SHIPPING WEIGHTS (lb.) ♦							
MODEL	E17	E20	E24	E26	E30	E35	E43
XSUS	27	33	49	55	71	97	187
MSUS	29	36	53	59	78	101	196
CSUS	36	41	62	68	90	104	205

All motorized weights are for 48C to 140TC adaptor sizes. Add 10% for 180TC/210TC adaptor sizes.

♦Weights are approximate and include shipping carton.

DIMENSIONS

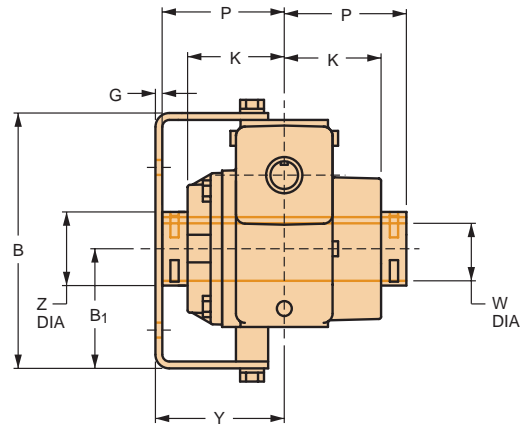
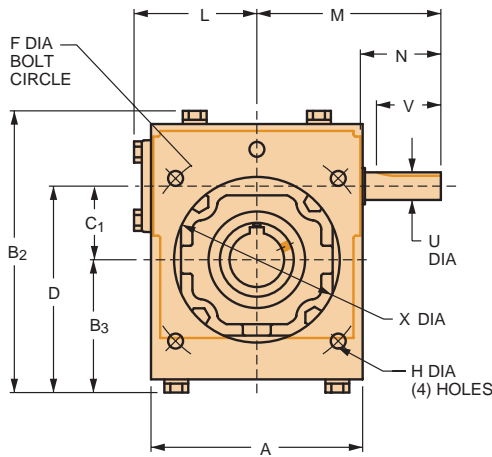

SPEED REDUCER DIMENSIONS (in.)

Size	A	B	B ₁	B ₂	B ₃	C ₁	D	E	G	H	K	L	M	P	X	Y	Z	INPUT SHAFT			
																		U*	N	V	KEYWAY
E17	4.81	6.25	2.81	7.02	3.20	1.750	4.95	5.875	.19	.344	2.44	3.44	4.75	3.13	4.06	3.50	1.49	.750	1.94	1.69	3/16x3/32
E20	5.75	6.94	3.25	7.71	3.64	2.000	5.64	6.500	.19	.406	2.63	3.44	5.00	3.31	4.50	3.50	2.00	.750	2.19	1.75	3/16x3/32
E24	6.13	8.00	3.44	9.03	3.96	2.375	6.34	7.500	.19	.406	2.75	4.50	6.50	3.44	5.00	3.69	2.25	1.000	2.75	2.38	1/4x1/8
E26	7.19	8.63	3.63	9.66	4.14	2.625	6.77	8.000	.25	.406	2.81	4.50	6.50	3.50	6.00	3.82	2.50	1.000	2.75	2.38	1/4x1/8
E30	8.50	10.19	4.44	11.22	4.95	3.000	7.95	9.250	.25	.563	3.00	4.63	7.00	3.69	7.00	5.00	2.63	1.000	3.06	2.38	1/4x1/8
E35	8.50	11.00	4.63	12.27	5.26	3.500	8.76	10.000	.25	.563	3.38	5.06†	7.38	4.13	7.00	5.06	2.87	1.000	2.31	2.50	1/4x1/8
E43	10.00	13.00	5.50	14.27	6.13	4.250	10.38	11.500	.38	.688	3.63	5.88‡	8.19	4.38	8.00	5.75	3.88	1.250	2.31	2.50	1/4x1/8

* Shaft diameter tolerances +.000 -0.01 Dimensions shown are for construction purposes only.
 † L dimension equals 5.46 on E35 MSUS model ‡ L dimension equals 6.28 on E43 MSUS model
 Please contact Winsmith for certified dimension sheets.

HOLLOW OUTPUT SHAFT BORES

(S) Standard Bore (M) Machined to Size Bore (B) Bushing*
 *Bushing for use with standard bore only

W**	KEYWAY	E17	E20	E24	E26	E30	E35	E43
.625	5/8	3/16x3/32	M/B					
.750	3/4	3/16x3/32	M/B	B				
.875	7/8	3/16x3/32	S	B				
1.000	1	1/4x1/8	S	M/B	M/B	B		
1.125	1-1/8	1/4x1/8	B	M/B	B			
1.188	1-3/16	1/4x1/8	M/B	B	B			
1.250	1-1/4	1/4x1/8	M/B	M/B	M/B	M/B	M/B	
1.375	1-3/8	5/16x5/32		B	B	B		
*1.438	1-7/16	3/8x3/16	S	M/B	B	B	M/B	
1.500	1-1/2	3/8x3/16		S	M/B	M/B	M/B	B
1.625	1-5/8	3/8x3/16						S
1.688	1-11/16	3/8x3/16			S	M/B	S	S
1.750	1-3/4	3/8x3/16				B	B	B
1.875	1-7/8	1/2x1/4					S	B
*1.938	1-15/16	1/2x1/4				S	M/B	M/B
2.000	2	1/2x1/4					M/B	S
*2.188	2-3/16	1/2x1/4					S	M/B
2.250	2-1/4	1/2x1/4						B
2.438	2-7/16	5/8x5/16						M/B
2.500	2-1/2	5/8x5/16						B
2.750	2-3/4	5/8x5/16						S

AVAILABLE SHAFT ARRANGEMENTS AND RELATIVE SHAFT ROTATIONS

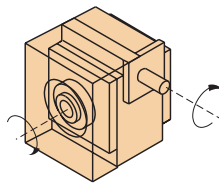

ASSEMBLY DL

The input shaft may be driven in either direction.

** Bore tolerances +.000 +.002 Two puller slots opposed on all hollow output shafts
 * Bore size 1.438 on size E20; keyway is 3/8x1/8. * Bore size 1.938 on size E30; keyway is 1/2x3/16
 * Bore size 2.188 on size E35; keyway is 1/2x1/8. Contact Winsmith for other bore sizes



Integral

MSUS - CSUS Single Reduction Models

MSUS
 "U" Flange
 Quill Input Adaptor
 Hollow Output Shaft
 Bracket Mount

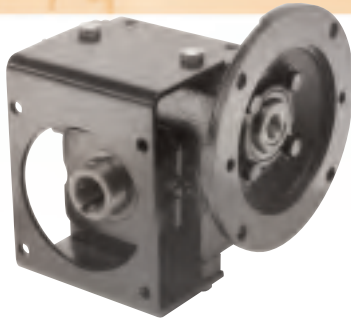

CSUS
 "U" Flange
 Coupled Input Adaptor
 Hollow Output Shaft
 Bracket Mount

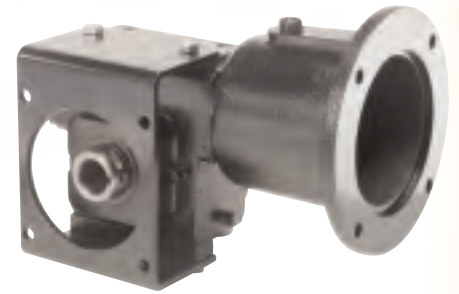

Couplings available, see page 106 for selection chart.

DIMENSIONS

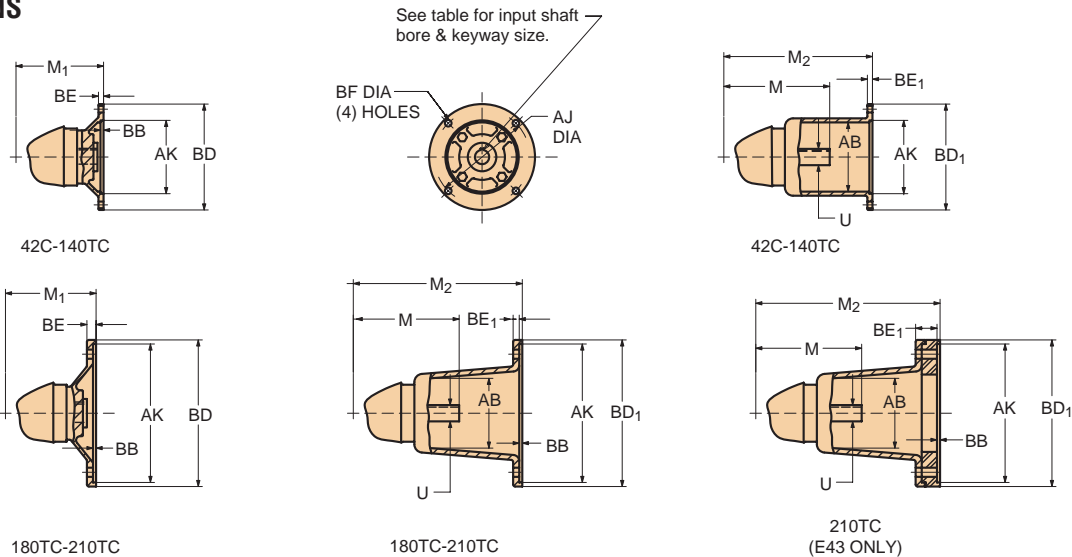

Size	QUILL INPUT ADAPTOR				COUPLED INPUT ADAPTOR														
	M ₁ 42C-48C	M ₁ 56C-140TC	M ₁ 180TC	M ₁ 210TC	42C-48C			56C-140TC			180TC			210TC			M	U	KEYWAY
	AB	M ₂	BE ₁	AB	M ₂	BE ₁	AB	M ₂	BE ₁	AB	M ₂	BE ₁							
E17	4.06	4.06	NA	NA	2.50	7.56	.38	3.75	7.50	.38	3.75	8.44	.50	NA			4.75	.750	3/16x3/32
E20	4.06	4.06	NA	NA	2.50	7.56	.38	3.75	7.50	.38	3.75	8.44	.50	NA			5.00	.750	3/16x3/32
E24	NA	5.38	5.38	NA	NA			4.13	9.13	.38	4.25	10.19	.50	NA			6.50	1.000	3/16x3/32
E26	NA	5.38	5.38	NA	NA			4.13	9.13	.38	4.25	10.19	.50	NA			6.50	1.000	1/4x1/8
E30	NA	5.56	5.56	NA	NA			4.13	9.75	.38	4.75	10.88	.50	4.75	10.88	.50	7.00	1.000	1/4x1/8
E35	NA	5.81	5.81	NA	NA			4.13	10.00	.38	4.75	11.13	.50	4.75	11.13	.50	7.38	1.000	1/4x1/8
E43	NA	6.63	6.63	6.63	NA			4.13	10.81	.38	4.75	11.94	.50	4.75	12.88	1.44	8.19	1.250	1/4x1/8

AVAILABLE SHAFT ARRANGEMENTS AND RELATIVE SHAFT ROTATIONS

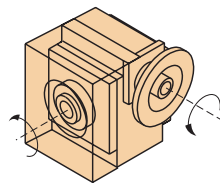

ASSEMBLY DL

The input shaft may be driven in either direction.

INPUT ADAPT. DIM.	42C 48C	56C	140TC	180TC	210TC
AJ	3.75	5.88	5.88	7.25	7.25
AK	3.00	4.50	4.50	8.50	8.50
BB	.19	.19	.19	.19	.19
BD	4.50	6.50	6.50	9.00	9.00
BD ₁	4.50	6.63	6.63	9.00	9.00
BE	.34	.31	.31	.38	.38
BF	.281	.406	.406	.531	.531
KEYWAY	1/8 x 1/16	3/16 x 3/32		1/4 x 1/8	5/16 x 5/32
BORE ^{+0.01} / _{-.000}	.5005*	.6255	.8755	1.1255	1.3755

*42C adaptor has .3755 bore, 3/32 x 3/64 keyway



2D DRAWINGS & 3D MODELS
 www.WINSMITH.com



XSHS Single Reduction Model

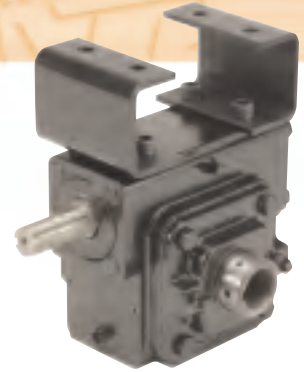

XSHS
Hanger
Solid Input Shaft
Hollow Output Shaft
Bracket Mount

SHIPPING WEIGHTS (lb.) ♦						
MODEL	E17	E20	E24	E26	E30	E35
XSHS	27	32	49	54	67	97
MSHS	29	35	53	58	74	101
CSHS	36	40	62	67	86	104

All motorized weights are for 48C to 140TC adaptor sizes. Add 10% for 180TC/210TC adaptor sizes.

♦ Weights are approximate and include shipping carton.

DIMENSIONS

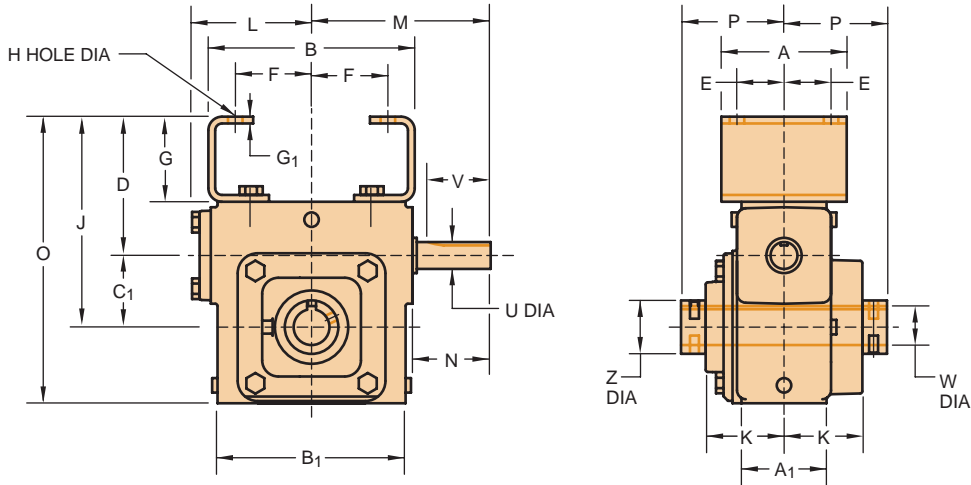

SPEED REDUCER DIMENSIONS (in.)

Size	A	A ₁	B	B ₁	C ₁	D	E	F	G	G ₁	H	J	K	L	M	O	P	Z	INPUT SHAFT			
																			U*	N	V	KEYWAY
E17	3.38	2.38	5.75	4.63	1.750	3.88	.88	1.94	2.38	.19	.390	5.63	2.44	3.44	4.75	7.75	3.13	1.49	.750	1.94	1.69	3/16x3/32
E20	3.50	2.38	5.88	5.25	2.000	3.88	.88	2.19	2.38	.19	.390	5.88	2.63	3.44	5.00	8.00	3.31	2.00	.750	2.19	1.75	3/16x3/32
E24	4.13	3.13	7.75	5.38	2.375	4.50	1.13	2.19	2.50	.25	.515	6.88	2.75	4.50	6.50	9.75	3.44	2.25	1.000	2.75	2.38	1/4x1/8
E26	4.13	3.13	8.25	5.88	2.625	4.63	1.13	2.44	2.50	.25	.515	7.25	2.81	4.50	6.50	10.38	3.50	2.50	1.000	2.75	2.38	1/4x1/8
E30	5.50	3.50	8.88	6.62	3.000	5.50	2.19	3.31	3.00	.25	.531	8.50	3.00	4.63	7.00	12.00	3.69	2.63	1.000	3.06	2.38	1/4x1/8
E35	5.02	3.75	9.25	7.69	3.500	5.00	1.31	3.25	2.38	.31	.656	8.50	3.38	5.06†	7.38	12.50	4.13	2.87	1.000	2.31	2.50	1/4x1/8

* Shaft diameter tolerances +.000 -.001 Dimensions shown are for construction purposes only.
† L dimension equals 5.46 on MSHS model. Please contact Winsmith for certified dimension sheets.

HOLLOW OUTPUT SHAFT BORES

(S) Standard Bore (M) Machined to Size Bore (B) Bushing*
*Bushing for use with standard bore only

W**	KEYWAY	E17	E20	E24	E26	E30	E35
.625	5/8	3/16x3/32	M/B				
.750	3/4	3/16x3/32	M/B	B			
.875	7/8	3/16x3/32	S	B			
1.000	1	1/4x1/8	S	M/B	M/B	B	
1.125	1-1/8	1/4x1/8		B	M/B	B	
1.188	1-3/16	1/4x1/8		M/B	B	B	
1.250	1-1/4	1/4x1/8		M/B	M/B	M/B	M/B
1.375	1-3/8	5/16x5/32			B	B	B
*1.438	1-7/16	3/8x3/16		S	M/B	B	M/B
1.500	1-1/2	3/8x3/16			S	M/B	M/B
1.625	1-5/8	3/8x3/16					
1.688	1-11/16	3/8x3/16				S	M/B
1.750	1-3/4	3/8x3/16					B
1.875	1-7/8	1/2x1/4					S
*1.938	1-15/16	1/2x1/4					S
2.000	2	1/2x1/4					M/B
*2.188	2-3/16	1/2x1/4					S
2.250	2-1/4	1/2x1/4					
2.438	2-7/16	5/8x5/16					
2.500	2-1/2	5/8x5/16					
2.750	2-3/4	5/8x5/16					

** Bore tolerances +.000 +.002 Two puller slots opposed on all hollow output shafts
* Bore size 1.438 on size E20: keyway is 3/8x1/8. *Bore size 1.938 on size E30: keyway is 1/2x3/16
* Bore size 2.188 on size E35: keyway is 1/2x1/8. Contact Winsmith for other bore sizes

AVAILABLE SHAFT ARRANGEMENTS AND RELATIVE SHAFT ROTATIONS

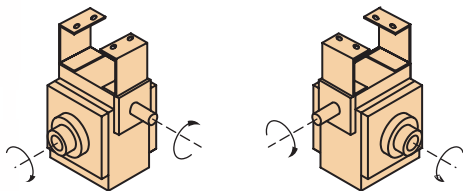

ASSEMBLY DLR

The input shaft may be driven in either direction.



MSSH - CSHS Single Reduction Models

MSSH
Hanger
Quill Input Adaptor
Hollow Output Shaft
Bracket Mount



CSHS
Hanger
Coupled Input Adaptor
Hollow Output Shaft
Bracket Mount

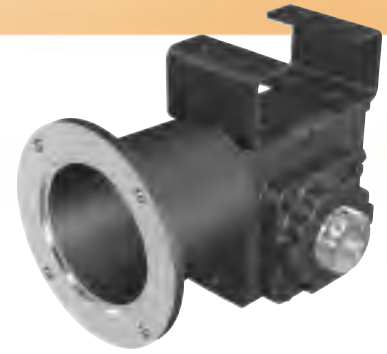

Couplings available, see page 106 for selection chart.

DIMENSIONS

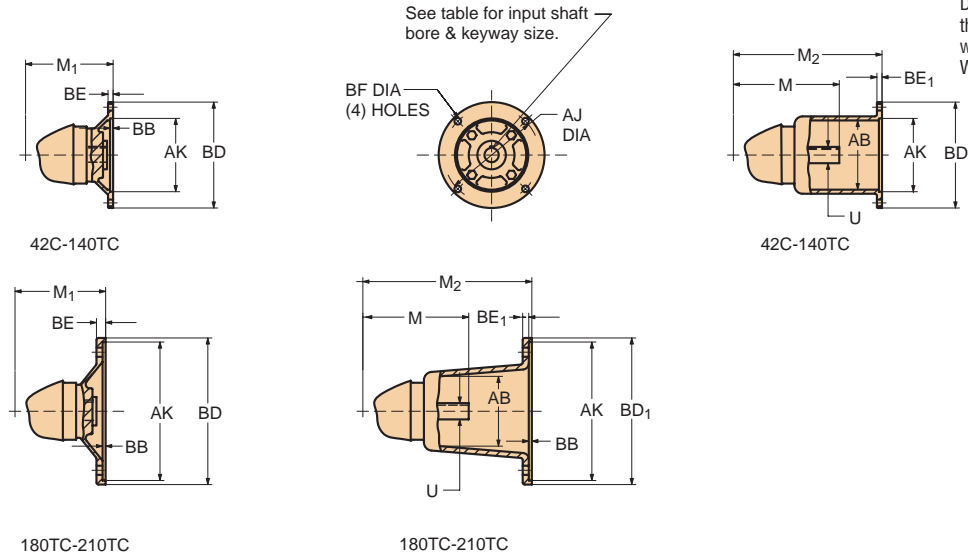

Size	QUILL INPUT ADAPTOR				COUPLED INPUT ADAPTOR														
	M ₁ 42C-48C	M ₁ 56C-140TC	M ₁ 180TC	M ₁ 210TC	42C-48C			56C-140TC			180TC			210TC			M	U	KEYWAY
					AB	M ₂	BE ₁	AB	M ₂	BE ₁	AB	M ₂	BE ₁	AB	M ₂	BE ₁			
E17	4.06	4.06	NA	NA	2.50	7.56	.38	NA			NA			NA			4.75	.750	3/16x3/32
E20	4.06	4.06	NA	NA	NA			NA			NA			NA			5.00	.750	3/16x3/32
E24	NA	5.38	NA	NA	NA			4.13	9.13	.38	4.25	10.19	.50	NA			6.50	1.000	1/4x1/8
E26	NA	5.38	NA	NA	NA			NA			NA			NA			6.50	1.000	1/4x1/8
E30	NA	5.56	5.56	NA	NA			4.13	9.75	.38	4.75	10.88	.50	4.75	10.88	.50	7.00	1.000	1/4x1/8
E35	NA	5.81	5.81	NA	NA			4.13	10.00	.38	4.75	11.13	.50	4.75	11.13	.50	7.38	1.000	1/4x1/8

AVAILABLE SHAFT ARRANGEMENTS AND RELATIVE SHAFT ROTATIONS

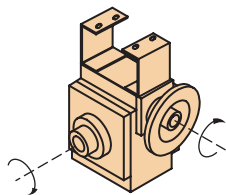

ASSEMBLY DLR

The input shaft may be driven in either direction.

INPUT ADAPT. DIM.	42C 48C	56C	140TC	180TC	210TC
AJ	3.75	5.88	5.88	7.25	7.25
AK	3.00	4.50	4.50	8.50	8.50
BB	.19	.19	.19	.19	.19
BD	4.50	6.50	6.50	9.00	9.00
BD ₁	4.50	6.63	6.63	9.00	9.00
BE	.34	.31	.31	.38	.38
BF	.281	.406	.406	.531	.531
KEYWAY	1/8 x 1/16	3/16 x 3/32		1/4 x 1/8	5/16 x 5/32
BORE ^{+0.001} / _{-0.000}	.5005*	.6255	.8755	1.1255	1.3755

*42C adaptor has .3755 bore, 3/32x3/64 keyway



2D DRAWINGS & 3D MODELS
www.WINSMITH.com



XSRS Single Reduction Model

SHIPPING WEIGHTS (lb.) ♦							
MODEL	E17	E20	E24	E26	E30	E35	E43
XSRS	28	33	49	54	74	115	163
MSRS	31	36	53	59	78	119	179
CSRS	35	44	58	66	84	125	173

All motorized weights are for 48C to 140TC adaptor sizes. Add 10% for 180TC/210TC adaptor sizes.

♦ Weights are approximate and include shipping carton.

XSRS
Torque Arm
Solid Input Shaft
Hollow Output Shaft
Bracket Mount



DIMENSIONS

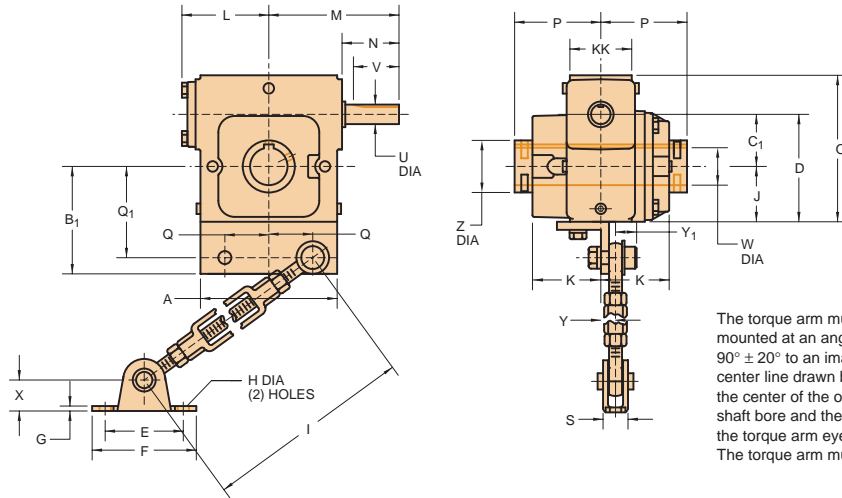

The torque arm must be mounted at an angle of $90^\circ \pm 20^\circ$ to an imaginary center line drawn between the center of the output shaft bore and the center of the torque arm eye bolt. The torque arm must be in tension.

SPEED REDUCER DIMENSIONS (in.)

Size	A	B ₁	C ₁	D	E	F	G	H	I MIN	I MAX	J	K	KK	L	M	O	P	Q	Q ₁	S	X	Y	Y ₁	Z	INPUT SHAFT			
																									U	N	V	KEYWAY
E17	4.63	4.13	1.750	3.88	3.00	4.00	.19	.44	15.00	24.00	2.13	2.44	2.38	3.44	4.75	5.38	3.13	1.69	3.50	.75	1.19	.63	.81	1.49	.750	1.94	1.69	3/16x3/32
E20	5.25	4.13	2.000	4.13	3.00	4.00	.19	.44	15.00	24.00	2.13	2.63	2.38	3.44	5.00	5.63	3.31	1.69	3.50	.75	1.19	.63	.81	2.00	.750	2.19	1.75	3/16x3/32
E24	5.38	4.88	2.375	5.25	3.00	4.00	.19	.44	15.00	24.00	2.88	2.75	3.13	4.50	6.50	7.25	3.44	2.13	4.25	.75	1.19	.31	.81	2.25	1.000	2.75	2.38	1/4x1/8
E26	5.88	5.13	2.625	5.75	3.00	4.00	.19	.44	15.00	24.00	3.13	2.81	3.13	4.50	6.50	7.88	3.50	2.31	4.50	.75	1.19	.44	.81	2.50	1.000	2.75	2.38	1/4x1/8
E30	6.50	5.50	3.000	6.50	3.00	4.00	.19	.44	15.00	24.00	3.50	3.00	3.50	4.63	7.00	9.00	3.69	2.56	4.88	.75	1.19	.44	.81	2.63	1.000	3.06	2.38	1/4x1/8
E35	7.75	6.50	3.500	7.50	3.50	4.75	.56	.53	21.00	29.00	4.00	3.38	3.75	5.06†	7.38	10.13	4.13	3.00	5.63	2.13	1.63	.88	1.09	2.87	1.000	2.31	2.50	1/4x1/8
E43	8.75	6.88	4.250	8.63	3.50	4.75	.56	.53	21.00	20.00	4.38	3.63	4.38	5.88‡	8.19	11.50	4.38	3.50	6.00	2.13	1.63	.56	1.09	3.88	1.250	2.31	2.50	1/4x1/8

* Shaft diameter tolerances +.000 - .001. Dimensions shown are for construction purposes only.
† L₁ dimension equals 5.46 on E35 MSRS model ‡ L₁ dimension equals 6.28 on E43 MSRS model
Please contact Winsmith for certified dimension sheets.

HOLLOW OUTPUT SHAFT BORES

(S) Standard Bore (M) Machined to Size Bore (B) Bushing*
*Bushing for use with standard bore only

W*	KEYWAY	E17	E20	E24	E26	E30	E35	E43
.625	5/8	3/16x3/32	M/B					
.750	3/4	3/16x3/32	M/B	B				
.875	7/8	3/16x3/32	S	B				
1.000	1	1/4x1/8	S	M/B	M/B	B		
1.125	1-1/8	1/4x1/8	B	M/B	B			
1.188	1-3/16	1/4x1/8	M/B	B	B			
1.250	1-1/4	1/4x1/8	M/B	M/B	M/B	M/B	M/B	
1.375	1-3/8	5/16x5/32		B	B	B		
*1.438	1-7/16	3/8x3/16	S	M/B	B	B	M/B	
1.500	1-1/2	3/8x3/16		S	M/B	M/B	M/B	B
1.625	1-5/8	3/8x3/16						S
1.688	1-11/16	3/8x3/16			S	M/B	S	S
1.750	1-3/4	3/8x3/16				B	B	B
1.875	1-7/8	1/2x1/4					S	B
*1.938	1-15/16	1/2x1/4				S	M/B	M/B
2.000	2	1/2x1/4					M/B	S
*2.188	2-3/16	1/2x1/4					S	M/B
2.250	2-1/4	1/2x1/4						B
2.438	2-7/16	5/8x5/16						M/B
2.500	2-1/2	5/8x5/16						B
2.750	2-3/4	5/8x5/16						S

** Bore tolerances +.000 +.002. Two puller slots opposed on all hollow output shafts.
* Bore size 1.438 on size E20; keyway is 3/8x1/8. * Bore size 1.938 on size E30; keyway is 1/2x3/16.
* Bore size 2.188 on size E35; keyway is 1/2x1/8. Contact Winsmith for other bore sizes.

AVAILABLE SHAFT ARRANGEMENTS AND RELATIVE SHAFT ROTATIONS

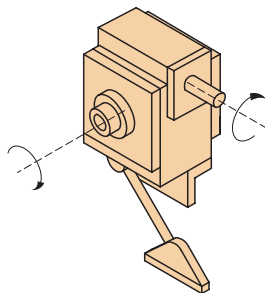

ASSEMBLY DLR

The input shaft may be driven in either direction.



MSRS - CSRS Single Reduction Models

MSRS
Torque Arm
Quill Input Adaptor
Hollow Output Shaft
Bracket Mount

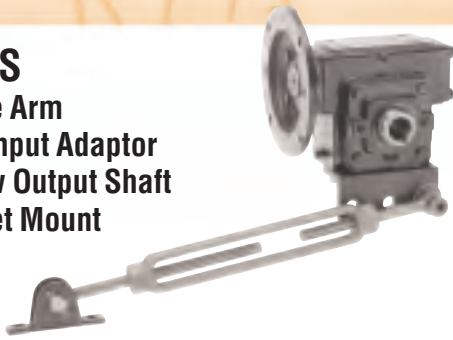

CSRS
Torque Arm
Coupled Input Adaptor
Hollow Output Shaft
Bracket Mount

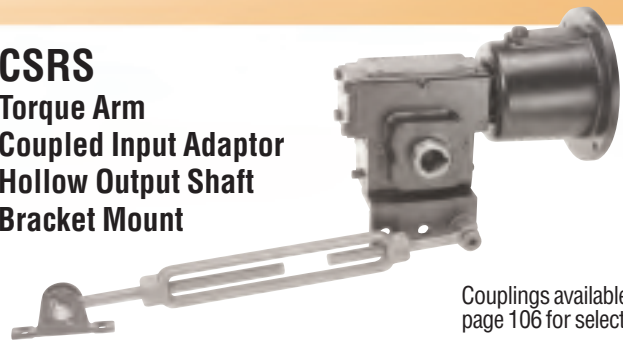

Couplings available, see page 106 for selection chart.

DIMENSIONS

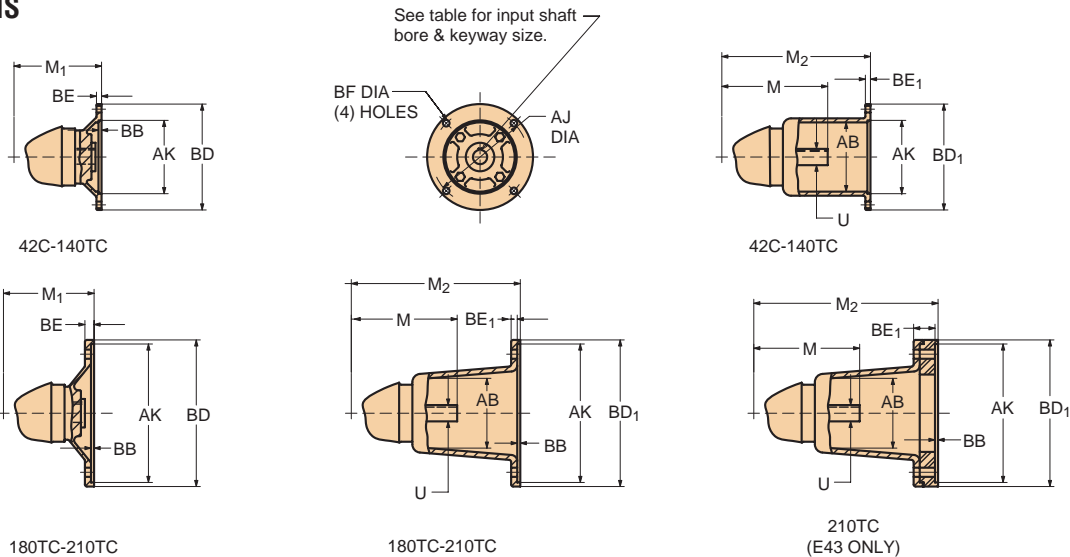

Size	QUILL INPUT ADAPTOR				COUPLED INPUT ADAPTOR														
	M ₁ 42C-48C	M ₁ 56C-140TC	M ₁ 180TC	M ₁ 210TC	42C-48C			56C-140TC			180TC			210TC			M	U	KEYWAY
					AB	M ₂	BE ₁	AB	M ₂	BE ₁	AB	M ₂	BE ₁	AB	M ₂	BE ₁			
E17	4.06	4.06	NA	NA	2.50	7.56	.38	3.75	7.50	.38	3.75	8.44	.50	NA			4.75	.750	3/16x3/32
E20	4.06	4.06	NA	NA	2.50	7.56	.38	3.75	7.50	.38	3.75	8.44	.50	NA			5.00	.750	3/16x3/32
E24	NA	5.38	5.38	NA	NA			4.13	9.13	.38	4.25	10.19	.50	NA			6.50	1.000	3/16x3/32
E26	NA	5.38	5.38	NA	NA			4.13	9.13	.38	4.25	10.19	.50	NA			6.50	1.000	1/4x1/8
E30	NA	5.56	5.56	NA	NA			4.13	9.75	.38	4.75	10.88	.50	4.75	10.88	.50	7.00	1.000	1/4x1/8
E35	NA	5.81	5.81	NA	NA			4.13	10.00	.38	4.75	11.13	.50	4.75	11.13	.50	7.38	1.000	1/4x1/8
E43	NA	6.63	6.63	6.63	NA			4.13	10.81	.38	4.75	11.94	.50	4.75	12.88	1.44	8.19	1.250	1/4x1/8

AVAILABLE SHAFT ARRANGEMENTS AND RELATIVE SHAFT ROTATIONS

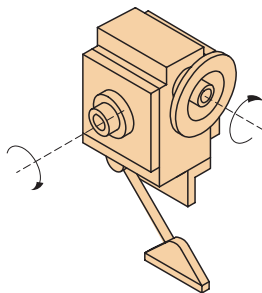

ASSEMBLY DLR

The input shaft may be driven in either direction.

INPUT ADAPT. DIM.	42C 48C	56C	140TC	180TC	210TC
AJ	3.75	5.88	5.88	7.25	7.25
AK	3.00	4.50	4.50	8.50	8.50
BB	.19	.19	.19	.19	.19
BD	4.50	6.50	6.50	9.00	9.00
BD ₁	4.50	6.63	6.63	9.00	9.00
BE	.34	.31	.31	.38	.38
BF	.281	.406	.406	.531	.531
KEYWAY	1/8 x 1/16	3/16 x 3/32		1/4 x 1/8	5/16 x 5/32
BORE +.001 -.000	.5005*	.6255	.8755	1.1255	1.3755

*42C adaptor has .3755 bore, 3/32 x 3/64 keyway



2D DRAWINGS & 3D MODELS
www.WINSMITH.com



XSFS Single Reduction Model



XSFS
Flange
Solid Input Shaft
Hollow Output Shaft
Flange Mount

SHIPPING WEIGHTS (lb.) ♦							
MODEL	E17	E20	E24	E26	E30	E35	E43
XSFS	26	32	46	53	74	104	191
MSFS	29	34	51	58	79	110	202
CSFS	33	38	59	67	84	124	209

All motorized weights are for 48C to 140TC adaptor sizes. Add 10% for 180TC/210TC adaptor sizes.

♦ Weights are approximate and include shipping carton.

DIMENSIONS

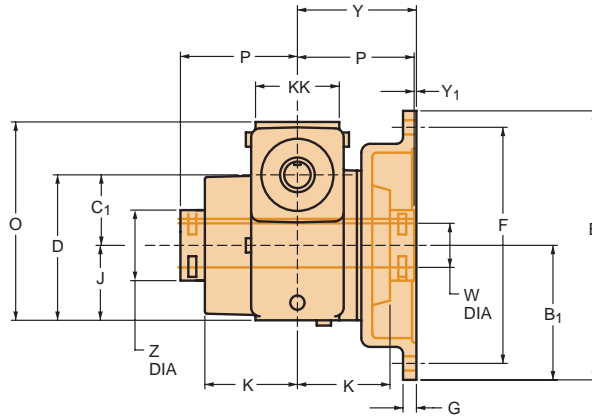
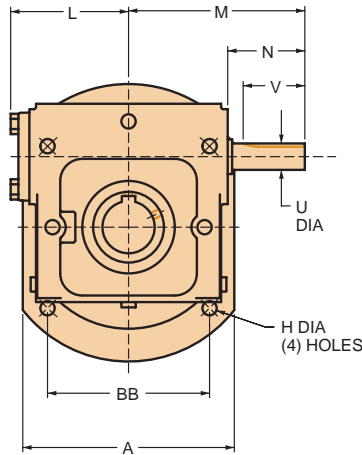

SPEED REDUCER DIMENSIONS (in.)

Size	A	B	B ₁	BB	C ₁	D	F _{DIA}	G	H	J	K	KK	L	M	O	P	Y	Y ₁	Z	INPUT SHAFT			
																				U*	N	V	KEYWAY
E17	4.88	6.75	3.38	4.63	1.750	3.88	5.875	.38	.344	2.13	2.44	2.38	3.44	4.75	5.38	3.13	3.50	.38	1.49	.750	1.94	1.69	3/16x3/32
E20	6.00	7.63	3.81	5.25	2.000	4.13	6.500	.38	.406	2.13	2.63	2.38	3.44	5.00	5.63	3.31	3.38	.06	2.00	.750	2.19	1.75	3/16x3/32
E24	7.75	8.63	4.31	5.38	2.375	5.25	7.500	.38	.406	2.88	2.75	3.13	4.50	6.50	7.25	3.44	3.50	.06	2.25	1.000	2.75	2.38	1/4x1/8
E26	7.75	9.13	4.56	5.88	2.625	5.75	8.000	.38	.406	3.13	2.81	3.13	4.50	6.50	7.88	3.50	3.63	.13	2.50	1.000	2.75	2.38	1/4x1/8
E30	8.00	10.75	5.38	6.62	3.000	6.50	9.250	.50	.563	3.50	3.00	3.50	4.63	7.00	9.00	3.69	5.00	1.31	2.63	1.000	3.06	2.38	1/4x1/8
E35	9.00	11.00	5.50	7.69	3.500	7.50	10.000	.50	.563	4.00	3.38	3.75	5.06†	7.38	10.13	4.13	5.00	.88	2.87	1.000	2.31	2.50	1/4x1/8
E43	10.50	13.00	6.50	8.75	4.250	8.63	11.500	.63	.688	4.38	3.63	4.38	5.88‡	8.19	11.50	4.38	5.75	1.38	3.88	1.250	2.31	2.50	1/4x1/8

* Shaft diameter tolerances +.000 -.001 Dimensions shown are for construction purposes only. Please contact Winsmith for certified dimension sheets.
 † L dimension equals 5.46 on E35 MSFS model ‡ L dimension equals 6.28 on E43 MSFS model

HOLLOW OUTPUT SHAFT BORES

(S) Standard Bore (M) Machined to Size Bore (B) Bushing*
 *Bushing for use with standard bore only

W**	KEYWAY	E17	E20	E24	E26	E30	E35	E43
.625	5/8	3/16x3/32	M/B					
.750	3/4	3/16x3/32	M/B	B				
.875	7/8	3/16x3/32	S	B				
1.000	1	1/4x1/8	S	M/B	M/B	B		
1.125	1-1/8	1/4x1/8	B	M/B	B			
1.188	1-3/16	1/4x1/8	M/B	B	B			
1.250	1-1/4	1/4x1/8	M/B	M/B	M/B	M/B	M/B	
1.375	1-3/8	5/16x5/32		B	B	B		
*1.438	1-7/16	3/8x3/16	S	M/B	B	B	M/B	
1.500	1-1/2	3/8x3/16		S	M/B	M/B	M/B	B
1.625	1-5/8	3/8x3/16						S
1.688	1-11/16	3/8x3/16			S	M/B	S	S
1.750	1-3/4	3/8x3/16				B	B	B
1.875	1-7/8	1/2x1/4					S	B
*1.938	1-15/16	1/2x1/4				S	M/B	M/B
2.000	2	1/2x1/4					M/B	S
*2.188	2-3/16	1/2x1/4					S	M/B
2.250	2-1/4	1/2x1/4						B
2.438	2-7/16	5/8x5/16						M/B
2.500	2-1/2	5/8x5/16						B
2.750	2-3/4	5/8x5/16						S

** Bore tolerances +.000 +.002 Two puller slots opposed on all hollow output shafts
 * Bore size 1.438 on size E20: keyway is 3/8x1/8. * Bore size 1.938 on size E30: keyway is 1/2x3/16
 * Bore size 2.188 on size E35: keyway is 1/2x1/8. Contact Winsmith for other bore sizes

AVAILABLE SHAFT ARRANGEMENTS AND RELATIVE SHAFT ROTATIONS

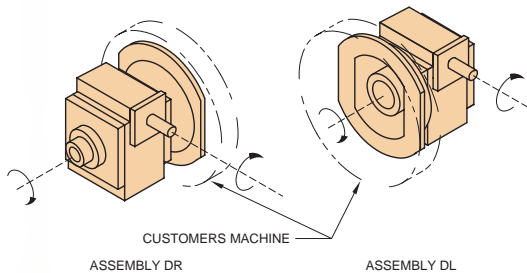

The input shaft may be driven in either direction.



MSFS - CSFS Single Reduction Models

MSFS
Flange
Quill Input Adaptor
Hollow Output Shaft
Flange Mount



CSFS
Flange
Coupled Input Adaptor
Hollow Output Shaft
Flange Mount



Couplings available, see page 106 for selection chart.

DIMENSIONS

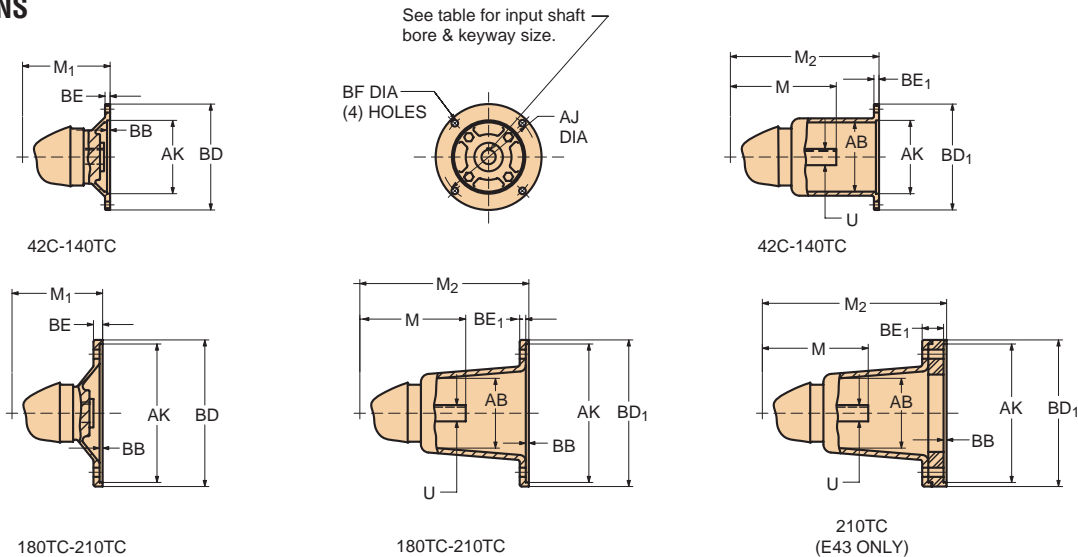

Size	QUILL INPUT ADAPTOR				COUPLED INPUT ADAPTOR														
	M ₁ 42C-48C	M ₁ 56C-140TC	M ₁ 180TC	M ₁ 210TC	42C-48C			56C-140TC			180TC			210TCC			M	U	KEYWAY
					AB	M ₂	BE ₁	AB	M ₂	BE ₁	AB	M ₂	BE ₁	AB	M ₂	BE ₁			
E17	4.06	4.06	NA	NA	2.50	7.56	.38	3.75	7.50	.38	3.75	8.44	.50	NA			4.75	.750	3/16x3/32
E20	4.06	4.06	NA	NA	2.50	7.56	.38	3.75	7.50	.38	3.75	8.44	.50	NA			5.00	.750	3/16x3/32
E24	NA	5.38	5.38	NA	NA			4.13	9.13	.38	4.25	10.19	.50	NA			6.50	1.000	3/16x3/32
E26	NA	5.38	5.38	NA	NA			4.13	9.13	.38	4.25	10.19	.50	NA			6.50	1.000	1/4x1/8
E30	NA	5.56	5.56	NA	NA			4.13	9.75	.38	4.75	10.88	.50	4.75	10.88	.50	7.00	1.000	1/4x1/8
E35	NA	5.81	5.81	NA	NA			4.13	10.00	.38	4.75	11.13	.50	4.75	11.13	.50	7.38	1.000	1/4x1/8
E43	NA	6.63	6.63	6.63	NA			4.13	10.81	.38	4.75	11.94	.50	4.75	12.88	1.44	8.19	1.250	1/4x1/8

AVAILABLE SHAFT ARRANGEMENTS AND RELATIVE SHAFT ROTATIONS

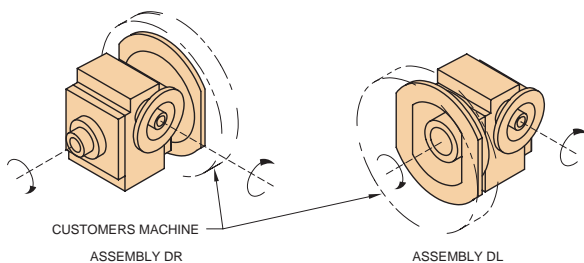

The input shaft may be driven in either direction.

INPUT ADAPT. DIM.	42C 48C	56C	140TC	180TC	210TC
AJ	3.75	5.88	5.88	7.25	7.25
AK	3.00	4.50	4.50	8.50	8.50
BB	.19	.19	.19	.19	.19
BD	4.50	6.50	6.50	9.00	9.00
BD ₁	4.50	6.63	6.63	9.00	9.00
BE	.34	.31	.31	.38	.38
BF	.281	.406	.406	.531	.531
KEYWAY	1/8 x 1/16	3/16 x 3/32		1/4 x 1/8	5/16 x 5/32
BORE ^{+0.01} / _{-0.00}	.5005*	.6255	.8755	1.1255	1.3755

*42C adaptor has .3755 bore, 3/32 x 3/64 keyway



2D DRAWINGS & 3D MODELS
www.WINSMITH.com



Helical/Worm Double Reduction Models Quick Select

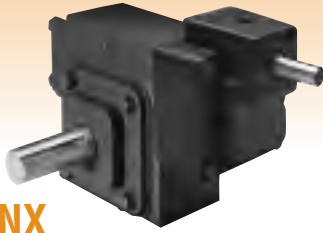

XDNX

Universal
Solid Input Shaft
Solid Output Shaft
Housing Mount

See Page 72



MDNX

Universal
Quill Input Adaptor
Solid Output Shaft
Housing Mount

See Page 73



CDNX

Universal
Coupled Input Adaptor
Solid Output Shaft
Housing Mount

See Page 73

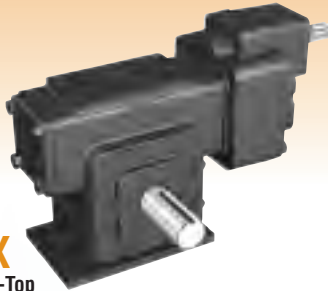

XDTX

Worm-On-Top
Solid Input Shaft
Solid Output Shaft
Base Mount

See Page 74

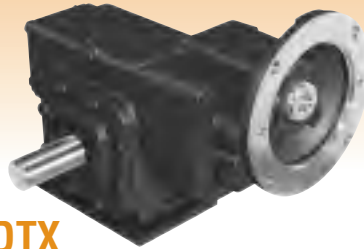

MDTX

Worm-On-Top
Quill Input Adaptor
Solid Output Shaft
Base Mount

See Page 74



CDTX

Worm-On-Top
Coupled Input Adaptor
Solid Output Shaft
Base Mount

See Page 74



XDBX

Worm-On-Bottom
Solid Input Shaft
Solid Output Shaft
Base Mount

See Page 74

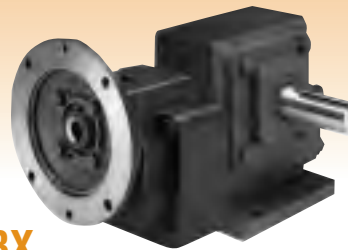

MDBX

Worm-On-Bottom
Quill Input Adaptor
Solid Output Shaft
Base Mount

See Page 74



CDBX

Worm-On-Bottom
Coupled Input Adaptor
Solid Output Shaft
Base Mount

See Page 74

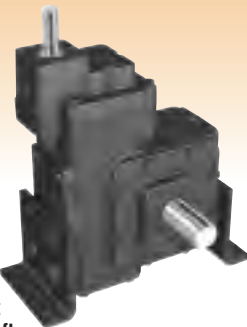

XDJX

"J" Vertical
Solid Input Shaft
Solid Output Shaft
Bracket Mount

See Page 75



MDJX

"J" Vertical
Quill Input Adaptor
Solid Output Shaft
Bracket Mount

See Page 75

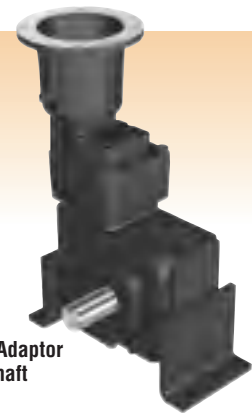

CDJX

"J" Vertical
Coupled Input Adaptor
Solid Output Shaft
Bracket Mount

See Page 75



Helical/Worm Double Reduction Models Quick Select



XDUX
 "U" Flange
 Solid Input Shaft
 Solid Output Shaft
 Bracket Mount
 See Page 75



MDUX
 "U" Flange
 Quill Input Adaptor
 Solid Output Shaft
 Bracket Mount
 See Page 75



CDUX
 "U" Flange
 Coupled Input Adaptor
 Solid Output Shaft
 Bracket Mount
 See Page 75

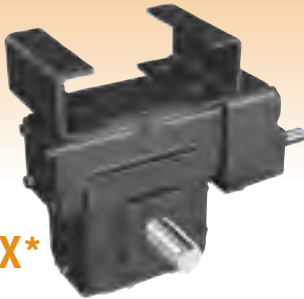

XDHX*
 Hanger
 Solid Input Shaft
 Solid Output Shaft
 Bracket Mount
 See Page 75



MDHX*
 Hanger
 Quill Input Adaptor
 Solid Output Shaft
 Bracket Mount
 See Page 75



CDHX*
 Hanger
 Coupled Input Adaptor
 Solid Output Shaft
 Bracket Mount
 See Page 75

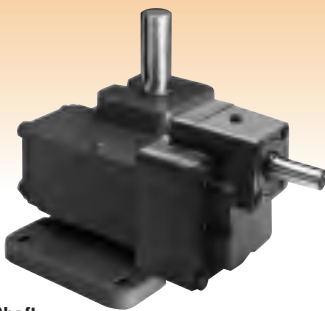

XDVX
 Vertical
 Solid Input Shaft
 Solid Output Shaft
 Flange Mount
 See Page 76



MDVX
 Vertical
 Quill Input Adaptor
 Solid Output Shaft
 Flange Mount
 See Page 77



CDVX
 Vertical
 Coupled Input Adaptor
 Solid Output Shaft
 Flange Mount
 See Page 77



XDLX
 Drop Bearing
 Solid Input Shaft
 Solid Output Shaft
 Flange Mount
 See Page 78



MDLX
 Drop Bearing
 Quill Input Adaptor
 Solid Output Shaft
 Flange Mount
 See Page 79



CDLX
 Drop Bearing
 Coupled Input Adaptor
 Solid Output Shaft
 Flange Mount
 See Page 79

* Brackets not available when a primary reducer is mounted with input shaft and pinion over gear.

Helical/Worm Double Reduction Models Quick Select

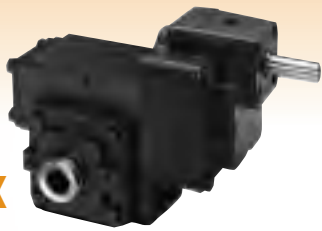

XDSX
 Universal
 Solid Input Shaft
 Hollow Output Shaft
 Housing Mount
 See Page 80



MDSX
 Universal
 Quill Input Adaptor
 Hollow Output Shaft
 Housing Mount
 See Page 81



CDSX
 Universal
 Coupled Input Adaptor
 Hollow Output Shaft
 Housing Mount
 See Page 81



XSTX
 Worm-On-Top
 Solid Input Shaft
 Hollow Output Shaft
 Base Mount
 See Page 82



MSTX
 Worm-On-Top
 Quill Input Adaptor
 Hollow Output Shaft
 Base Mount
 See Page 82



CSTX
 Worm-On-Top
 Coupled Input Adaptor
 Hollow Output Shaft
 Base Mount
 See Page 82



XSBX
 Worm-On-Bottom
 Solid Input Shaft
 Hollow Output Shaft
 Base Mount
 See Page 82



MSBX
 Worm-On-Bottom
 Quill Input Adaptor
 Hollow Output Shaft
 Base Mount
 See Page 82



CSBX
 Worm-On-Bottom
 Coupled Input Adaptor
 Hollow Output Shaft
 Base Mount
 See Page 82



XSJX
 "J" Vertical
 Solid Input Shaft
 Hollow Output Shaft
 Bracket Mount
 See Page 82



MSJX
 "J" Vertical
 Quill Input Adaptor
 Hollow Output Shaft
 Bracket Mount
 See Page 82



CSJX
 "J" Vertical
 Coupled Input Adaptor
 Hollow Output Shaft
 Bracket Mount
 See Page 82

Integral

Helical/Worm Double Reduction Models Quick Select



XSUX
 "U" Flange
 Solid Input Shaft
 Hollow Output Shaft
 Bracket Mount
 See Page 83

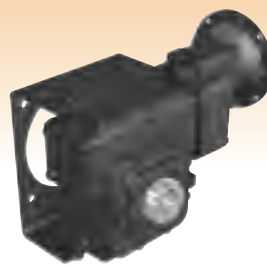

MSUX
 "U" Flange
 Quill Input Adaptor
 Hollow Output Shaft
 Bracket Mount
 See Page 83



CSUX
 "U" Flange
 Coupled Input Adaptor
 Hollow Output Shaft
 Bracket Mount
 See Page 83



XSHX*
 Hanger
 Solid Input Shaft
 Hollow Output Shaft
 Bracket Mount
 See Page 83



MSHX*
 Hanger
 Quill Input Adaptor
 Hollow Output Shaft
 Bracket Mount
 See Page 83

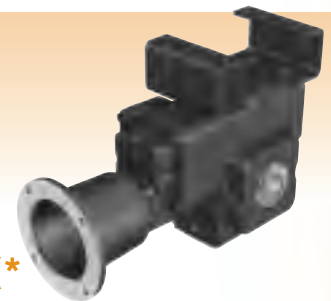

CSHX*
 Hanger
 Coupled Input Adaptor
 Hollow Output Shaft
 Bracket Mount
 See Page 83



XSRX
 Torque Arm
 Solid Input Shaft
 Hollow Output Shaft
 Bracket Mount
 See Page 83



MSRX
 Torque Arm
 Quill Input Adaptor
 Hollow Output Shaft
 Bracket Mount
 See Page 83



CSRX
 Torque Arm
 Coupled Input Adaptor
 Hollow Output Shaft
 Bracket Mount
 See Page 83

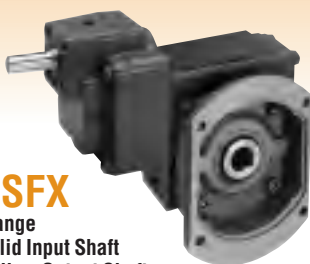

XSFx
 Flange
 Solid Input Shaft
 Hollow Output Shaft
 Flange Mount
 See Page 84



MSFxF
 Flange
 Quill Input Adaptor
 Hollow Output Shaft
 Flange Mount
 See Page 85



CSFxF
 Flange
 Coupled Input Adaptor
 Hollow Output Shaft
 Flange Mount
 See Page 85

* Brackets not available when a primary reducer is mounted with input shaft on top.



2D DRAWINGS & 3D MODELS
www.WINSMITH.com



XDNX Helical/Worm Double Reduction Model

XDNX
Universal
Solid Input Shaft
Solid Output Shaft
Housing Mount

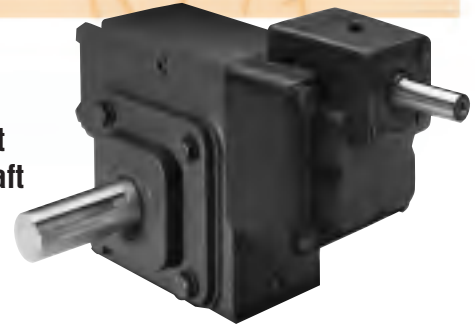

SHIPPING WEIGHTS (lb.) ♦					
MODEL	E24	E26	E30	E35	E43
XDNX	57	60	67	96	187
MDNX	60	64	70	98	191
CDNX	67	70	86	100	195

All motorized weights are for 48C to 140TC adaptor sizes. Add 10% for 180TC/210TC adaptor sizes.

♦Weights are approximate and include shipping carton.

DIMENSIONS

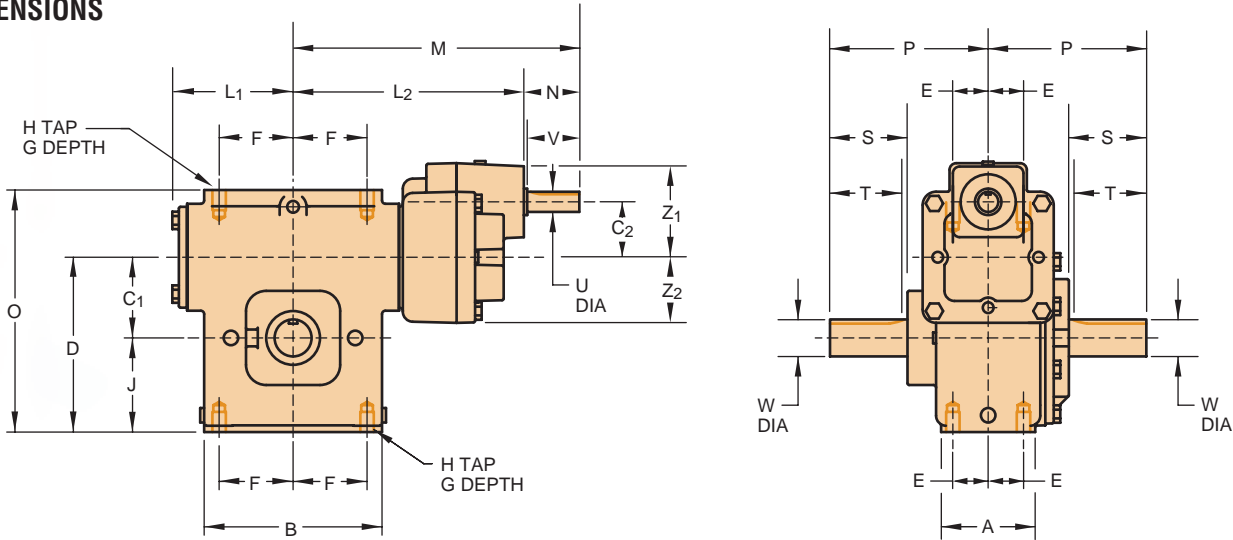

SPEED REDUCER DIMENSIONS (in.)

Size	A	B	C ₁	C ₂	D	E	F	G DEPTH	G ₁ DEPTH	H TAP	J	L ₁	L ₂	M	O	P	Z ₁	Z ₂	INPUT SHAFT			OUTPUT SHAFT				
																			U*	N	V	KEYWAY	W*	S	T	KEYWAY
E24	3.13	5.38	2.375	2.060	5.25	1.13	2.19	.63	.57	1/2-13	2.88	4.50	8.39	10.46	7.25	5.50	3.50	2.44	.750	2.06	1.81	3/16x3/32	1.250	2.81	2.63	1/4x1/8
E26	3.13	5.88	2.625	2.060	5.75	1.13	2.44	.69	.69	1/2-13	3.13	4.50	8.39	10.46	7.88	5.50	3.50	2.44	.750	2.06	1.81	3/16x3/32	1.250	2.81	2.63	1/4x1/8
E30	3.50	6.62	3.000	2.060	6.50	1.31	2.75	.75	.75	1/2-13	3.50	4.63	8.58	10.64	9.00	5.88	3.50	2.44	.750	2.06	1.81	3/16x3/32	1.375	2.88	2.75	5/16x5/32
E35	3.75	7.69	3.500	2.060	7.50	1.31	3.25	1.00	1.00	5/8-11	4.00	5.06	8.83	10.89	10.13	7.00	3.50	2.44	.750	2.06	1.81	3/16x3/32	1.750	3.75	3.63	3/8x3/16
E43	4.38	8.75	4.250	3.200	8.63	1.63	3.75	1.00	1.00	5/8-11	4.38	5.88	10.63	13.38	11.50	8.00	5.02	3.38	1.000	2.75	2.38	1/4x1/8	2.000	4.38	4.19	1/2x1/4

* Shaft diameter tolerances +.000 -.001 Dimensions shown are for construction purposes only. Please contact Winsmith for certified dimension sheets.

AVAILABLE SHAFT ARRANGEMENTS AND RELATIVE SHAFT ROTATIONS

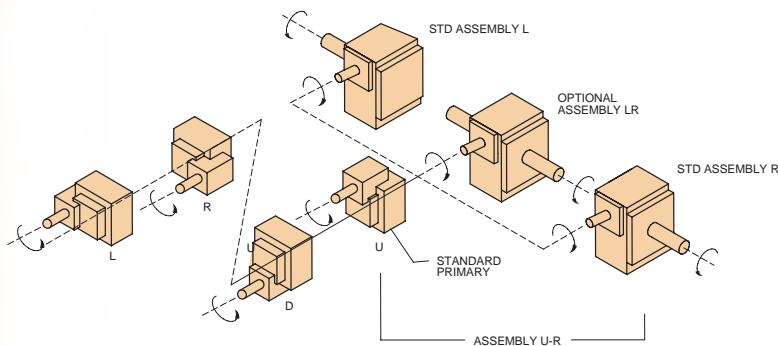

The input shaft may be driven in either direction.



MDNX - CDNX Helical/Worm Double Reduction Models

MDNX
 Universal
 Quill Input Adaptor
 Solid Output Shaft
 Housing Mount



CDNX
 Universal
 Coupled Input Adaptor
 Solid Output Shaft
 Housing Mount



Couplings available, see page 106 for selection chart.

DIMENSIONS

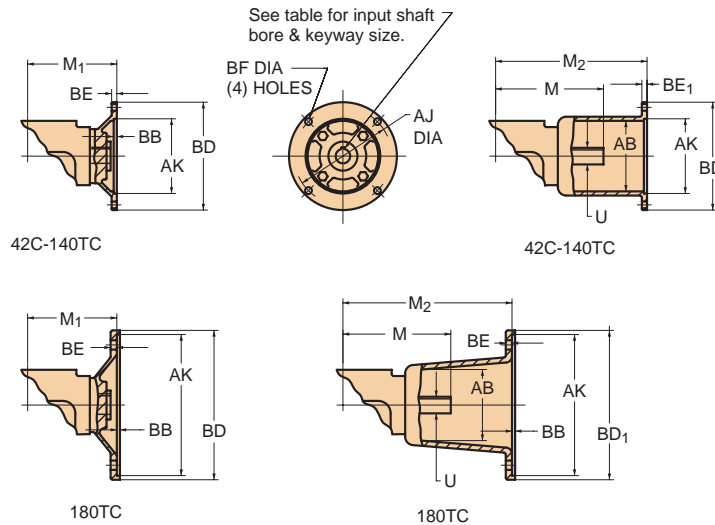

Size	QUILL INPUT ADAPTOR			COUPLED INPUT ADAPTOR									M	U	KEYWAY
	M ₁ 42C-48C	M ₁ 56C-140TC	M ₁ 180TC	42C-48TC			56C-140TC			180TC					
				AB	M ₂	BE ₁	AB	M ₂	BE ₁	AB	M ₂	BE ₁			
E24	9.65	9.65	NA	2.13	13.15	.38	3.75	13.09	.38				10.46	.750	3/16x3/32
E26	9.65	9.65	NA	2.13	13.15	.38	3.75	13.09	.38				10.46	.750	3/16x3/32
E30	9.84	9.84	NA	2.13	13.34	.38	3.75	13.28	.38				10.64	.750	3/16x3/32
E35	10.09	10.09	NA	2.13	13.59	.38	3.75	13.53	.38				10.89	.750	3/16x3/32
E43	NA	12.25	12.25		NA		4.13	16.00	.38	4.25	17.06	.50	13.38	1.000	1/4x1/8

AVAILABLE SHAFT ARRANGEMENTS AND RELATIVE SHAFT ROTATIONS

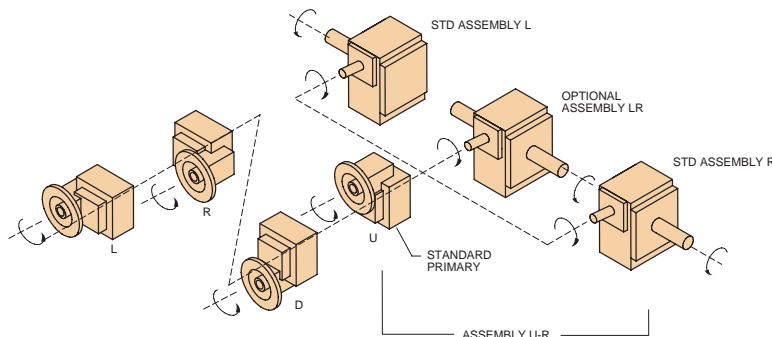

The input shaft may be driven in either direction.

INPUT ADAPT. DIM.	42C 48C	56C	140TC	180TC
AJ	3.75	5.88	5.88	7.25
AK	3.00	4.50	4.50	8.50
BB	.19	.19	.19	.19
BD	4.50	6.50	6.50	9.00
BD ₁	4.50	6.63	6.63	9.00
BE	.34	.31	.31	.38
BF	.281	.406	.406	.531
KEYWAY	1/8 x 1/16	3/16 x 3/32		1/4 x 1/8
BORE ^{+0.001} / _{-0.000}	.5005*	.6255	.8755	1.1255

*42C adaptor has .3755 bore, 3/32 x 3/64 keyway



2D DRAWINGS & 3D MODELS
 www.WINSMITH.com



XDTX - MDTX, XDBX - MDBX, Helical/Worm Double Reduction Models

SHIPPING WEIGHTS (lb.) ♦					
MODEL	E24	E26	E30	E35	E43
XDTX	59	63	78	123	199
MDTX	62	66	82	127	206
CDTX	68	70	86	155	211

All motorized weights are for 48C to 140TC adaptor sizes. Add 10% for 180TC/210TC adaptor sizes.

♦ Weights are approximate and include shipping carton.

SHIPPING WEIGHTS (lb.) ♦					
MODEL	E24	E26	E30	E35	E43
XDBX	57	63	78	113	206
MDBX	61	66	81	134	211
CDBX	63	69	84	119	215

All motorized weights are for 48C to 140TC adaptor sizes. Add 10% for 180TC/210TC adaptor sizes.

♦ Weights are approximate and include shipping carton.

Available Shaft Arrangements And Relative Shaft Rotations*

XDTX Worm-On-Top Solid Input Shaft Solid Output Shaft Base Mount

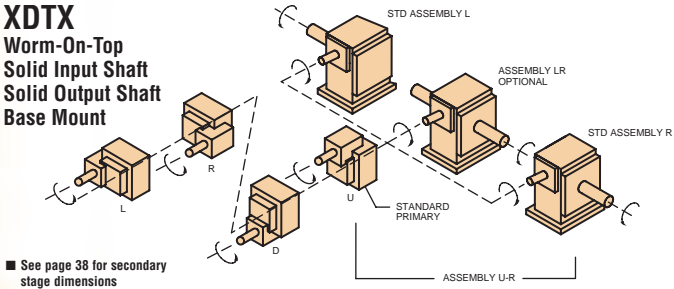

■ See page 38 for secondary stage dimensions

MDTX Worm-On-Top Quill Input Adaptor Solid Output Shaft Base Mount

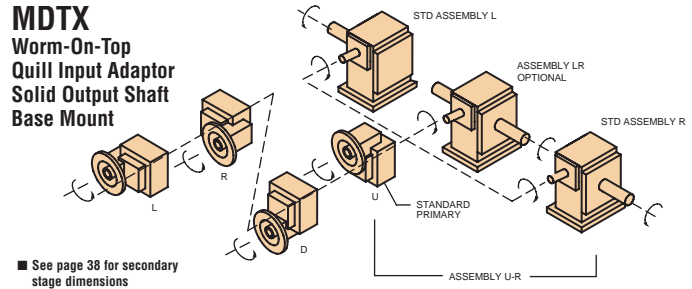

■ See page 38 for secondary stage dimensions

XDBX Worm-On-Bottom Solid Input Shaft Solid Output Shaft Base Mount

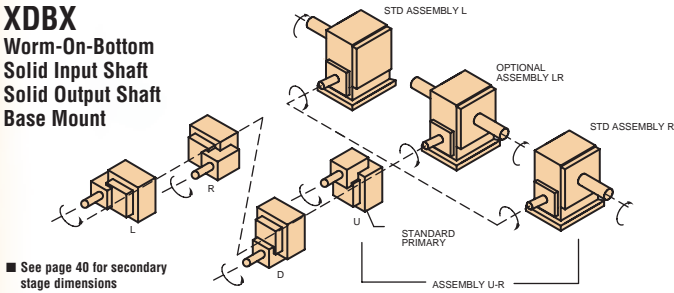

■ See page 40 for secondary stage dimensions

MDBX Worm-On-Bottom Quill Input Adaptor Solid Output Shaft Base Mount

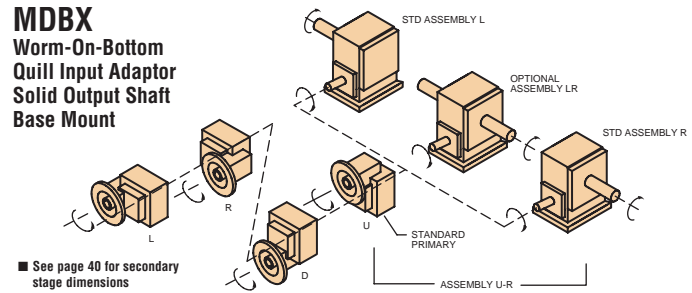

■ See page 40 for secondary stage dimensions

* The input shaft may be driven in either direction.

XDJX - MDJX, XDUX - MDUX, XDHX - MDHX, Helical/Worm Double Reduction Models

SHIPPING WEIGHTS (lb.) ♦					
MODEL	E24	E26	E30	E35	E43
XDJX	59	60	74	111	160
MDJX	64	67	83	115	165
CDJX	68	69	94	118	170

All motorized weights are for 48C to 140TC adaptor sizes. Add 10% for 180TC/210TC adaptor sizes.

♦ Weights are approximate and include shipping carton.

SHIPPING WEIGHTS (lb.) ♦					
MODEL	E24	E26	E30	E35	E43
XDUX	63	67	77	107	200
MDUX	66	71	84	109	204
CDUX	73	77	96	116	216

All motorized weights are for 48C to 140TC adaptor sizes. Add 10% for 180TC/210TC adaptor sizes.

♦ Weights are approximate and include shipping carton.

SHIPPING WEIGHTS (lb.) ♦					
MODEL	E24	E26	E30	E35	
XDHX	63	66	73	107	
MDHX	66	70	80	109	
CDHX	73	76	92	116	

All motorized weights are for 48C to 140TC adaptor sizes. Add 10% for 180TC/210TC adaptor sizes.

♦ Weights are approximate and include shipping carton.

Available Shaft Arrangements And Relative Shaft Rotations*

XDJX "J" Vertical Solid Input Shaft Solid Output Shaft Bracket Mount

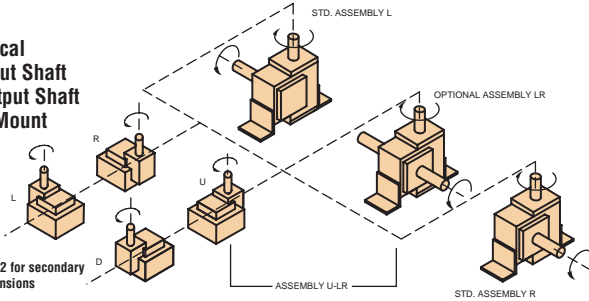

■ See page 42 for secondary stage dimensions

MDJX "J" Vertical Quill Input Adaptor Solid Output Shaft Bracket Mount

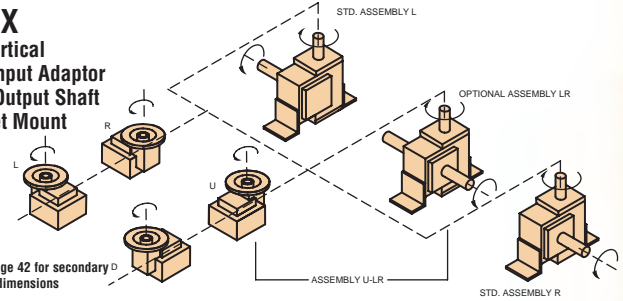

■ See page 42 for secondary stage dimensions

XDUX "U" Flange Solid Input Shaft Solid Output Shaft Bracket Mount

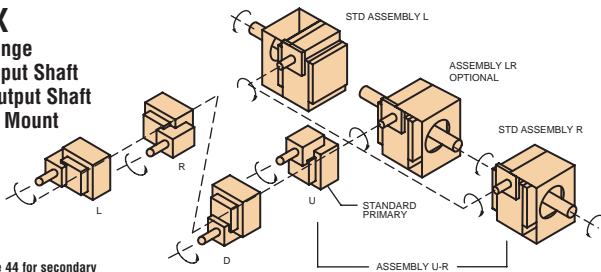

■ See page 44 for secondary stage dimensions

MDUX "U" Flange Quill Input Adaptor Solid Output Shaft Bracket Mount

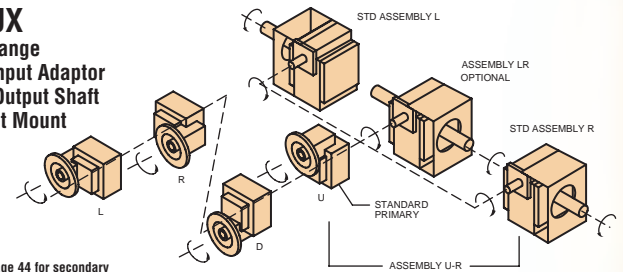

■ See page 44 for secondary stage dimensions

XDHX Hanger Solid Input Shaft Solid Output Shaft Bracket Mount

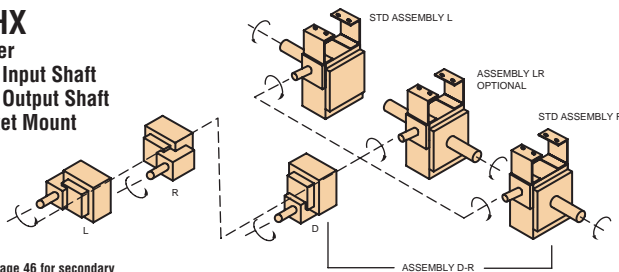

■ See page 46 for secondary stage dimensions

MDHX Hanger Quill Input Adaptor Solid Output Shaft Bracket Mount

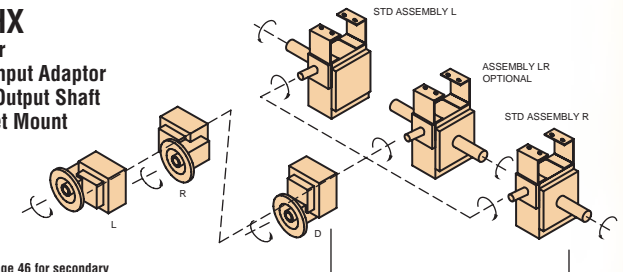

■ See page 46 for secondary stage dimensions

* The input shaft may be driven in either direction.



XDVX Helical/Worm Double Reduction Model

XDVX
Vertical
Solid Input Shaft
Solid Output Shaft
Flange Mount

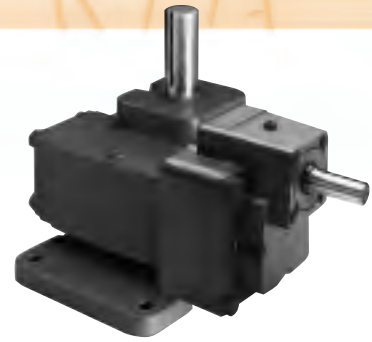

SHIPPING WEIGHTS (lb.) ♦					
MODEL	E24	E26	E30	E35	E43
XDVX	59	65	77	105	184
MDVX	62	69	80	108	200
CDVX	65	72	83	110	214

All motorized weights are for 48C to 140TC adaptor sizes. Add 10% for 180TC/210TC adaptor sizes.

♦Weights are approximate and include shipping carton.

DIMENSIONS

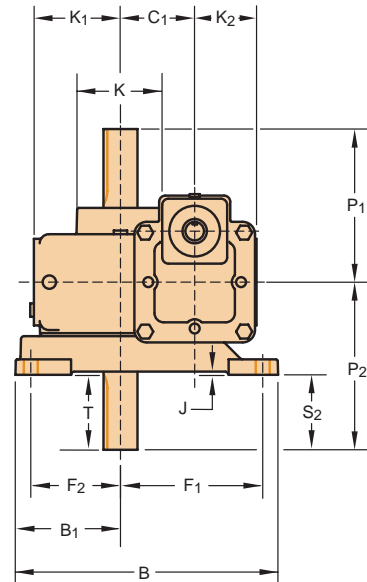
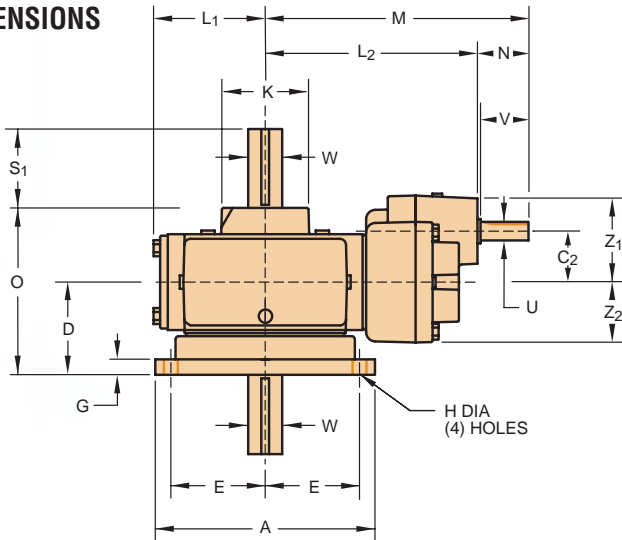

SPEED REDUCER DIMENSIONS (in.)

Size	A	B	B ₁	C ₁	C ₂	D	E	F ₁	F ₂	G	H	J	K	K ₁	K ₂	L ₁	L ₂	M	O	P ₁	P ₂	Z ₁	Z ₂	INPUT SHAFT			OUTPUT SHAFT					
																								U*	N	V	KEYWAY	W*	S ₁	S ₂	T	KEYWAY
E24	6.88	8.88	3.44	2.375	2.060	3.50	2.88	4.88	2.88	.50	.406	.13	3.25	2.88	2.00	4.50	8.39	10.46	6.13	5.75	6.38	3.50	2.44	.750	2.06	1.81	3/16 x 3/32	1250	3.12	2.88	2.75	1/4 x 1/8
E26	6.88	9.44	3.63	2.625	2.060	3.63	2.88	5.25	2.88	.50	.406	.13	3.50	3.13	2.13	4.50	8.39	10.46	6.26	5.63	6.38	3.50	2.44	.750	2.06	1.81	3/16 x 3/32	1250	3.00	2.75	2.75	1/4 x 1/8
E30	6.88	10.63	4.25	3.000	2.060	3.75	3.81	5.75	3.63	.63	.563	.13	3.50	3.50	2.50	4.63	8.58	10.64	6.75	6.19	6.75	3.50	2.44	.750	2.06	1.81	3/16 x 3/32	1375	3.19	3.00	3.06	5/16 x 5/32
E35	9.75	11.50	5.00	3.500	2.060	3.75	4.25	5.88	4.38	.63	.563	.13	4.13	4.00	2.63	5.06	8.83	10.89	7.00	7.00	7.00	3.50	2.44	.750	2.06	1.81	3/16 x 3/32	1750	3.75	3.25	3.63	3/8 x 3/16
E43	9.63	11.00	4.81	4.250	3.200	4.75	4.13	5.50	4.13	.63	.563	.13	4.75	4.38	2.88	5.88	10.63	13.38	8.38	8.00	8.00	5.02	3.38	1.000	2.75	2.38	1/4 x 1/8	2000	4.38	3.25	4.19	1/2 x 1/4

* Shaft diameter tolerances +.000 -.001 Dimensions shown are for construction purposes only. Please contact Winsmith for certified dimension sheets.

AVAILABLE SHAFT ARRANGEMENTS AND RELATIVE SHAFT ROTATIONS

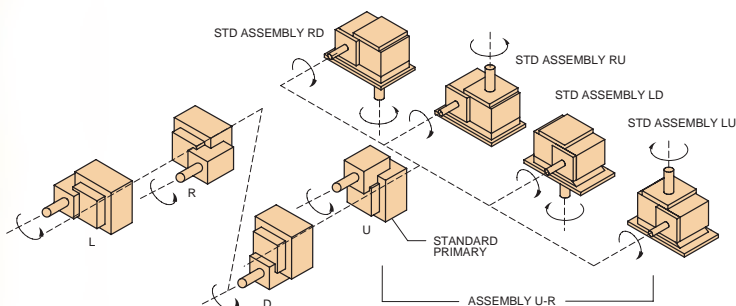

The input shaft may be driven in either direction.



MDVX - CDVX Helical/Worm Double Reduction Models

MDVX
Vertical
Quill Input Adaptor
Solid Output Shaft
Flange Mount



CDVX
Vertical
Coupled Input Adaptor
Solid Output Shaft
Flange Mount



Couplings available, see page 106 for selection chart.

DIMENSIONS

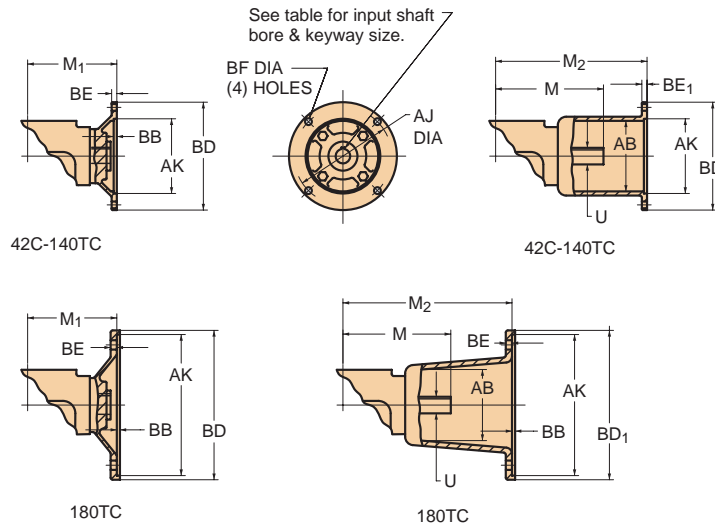

Size	QUILL INPUT ADAPTOR			COUPLED INPUT ADAPTOR									M	U	KEYWAY
	M ₁ 42C-48TC	M ₁ 56C-140TC	M ₁ 180TC	42C-48TC			56C-140TC			180TC					
				AB	M ₂	BE ₁	AB	M ₂	BE ₁	AB	M ₂	BE ₁			
E24	9.65	9.65	NA	2.13	13.15	.38	3.75	13.09	.38				10.46	.750	3/16x3/32
E26	9.65	9.65	NA	2.13	13.15	.38	3.75	13.09	.38				10.46	.750	3/16x3/32
E30	9.84	9.84	NA	2.13	13.34	.38	3.75	13.28	.38				10.64	.750	3/16x3/32
E35	10.09	10.09	NA	2.13	13.59	.38	3.75	13.53	.38				10.89	.750	3/16x3/32
E43	NA	12.25	12.25		NA		4.13	16.00	.38	4.25	17.06	.50	13.38	1.000	1/4x1/8

AVAILABLE SHAFT ARRANGEMENTS AND RELATIVE SHAFT ROTATIONS

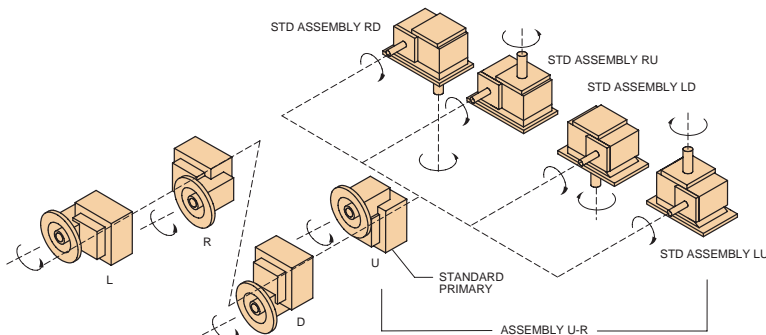

The input shaft may be driven in either direction.

INPUT ADAPT. DIM.	42C 48C	56C	140TC	180TC
AJ	3.75	5.88	5.88	7.25
AK	3.00	4.50	4.50	8.50
BB	.19	.19	.19	.19
BD	4.50	6.50	6.50	9.00
BD ₁	4.50	6.63	6.63	9.00
BE	.34	.31	.31	.38
BF	.281	.406	.406	.531
KEYWAY	1/8 x 1/16	3/16 x 3/32		1/4 x 1/8
BORE +.001 -.000	.5005*	.6255	.8755	1.1255

*42C adaptor has .3755 bore, 3/32 x 3/64 keyway



2D DRAWINGS & 3D MODELS
www.WINSMITH.com



XDLX Helical/Worm Double Reduction Model

XDLX
Drop Bearing
Solid Input Shaft
Solid Output Shaft
Flange Mount



SHIPPING WEIGHTS (lb.) ♦				
MODEL	E26	E30	E35	E43
XDLX	67	107	140	215
MDLX	73	111	144	220
CDLX	76	117	150	225

All motorized weights are for 48C to 140TC adaptor sizes. Add 10% for 180TC/210TC adaptor sizes.

♦Weights are approximate and include shipping carton.

DIMENSIONS

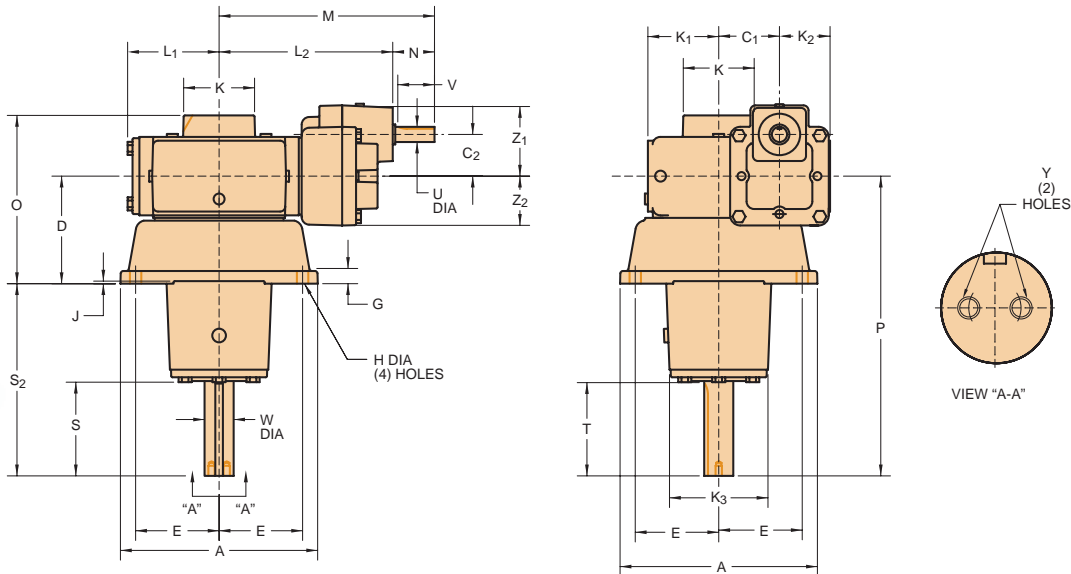

SPEED REDUCER DIMENSIONS (in.)

Size	A	C ₁	C ₂	D	E	G	H	J	K	K ₁	K ₂	K ₃	L ₁	L ₂	M	O	P	Z ₁	Z ₂	Y DIMENSIONS			INPUT SHAFT			OUTPUT SHAFT					
																				TAP	DEPTH	BOLT CIRCLE	U*	N	V	KEYWAY	W*	S	S ₂	T	KEYWAY
E26	9.00	2.625	2.060	4.44	4.00	.50	.406	.13	3.50	3.13	2.13	4.44	4.50	8.39	10.46	7.06	11.94	3.50	2.44	.25-.20	.44	.625	.750	2.06	1.81	3/16 x 3/32	1250	3.68	7.50	3.50	1/4 x 1/8
E30	9.75	3.000	2.060	5.31	4.13	.63	.563	.13	3.50	3.50	2.50	5.19	4.63	8.58	10.64	8.31	14.81	3.50	2.44	.31-18	.50	.750	.750	2.06	1.81	3/16 x 3/32	1438	4.63	9.50	4.56	3/8 x 3/16
E35	12.00	3.500	2.060	5.38	5.25	.75	.563	.13	4.13	4.00	2.63	5.38	5.06	8.83	10.89	8.63	14.88	3.50	2.44	.31-18	.50	.750	.750	2.06	1.81	3/16 x 3/32	1625	4.75	9.50	4.56	3/8 x 3/16
E43	14.00	4.250	3.200	6.00	6.00	.88	.688	.13	4.75	4.38	2.88	5.94	5.88	10.63	13.38	9.63	16.50	5.02	3.38	.38-16	1.00	1.000	1.000	2.75	2.38	1/4 x 1/8	1688	5.61	10.50	5.44	3/8 x 3/16

* Shaft diameter tolerances +.000 -.001. Dimensions shown are for construction purposes only. Please contact Winsmith for certified dimension sheets.

AVAILABLE SHAFT ARRANGEMENTS AND RELATIVE SHAFT ROTATIONS

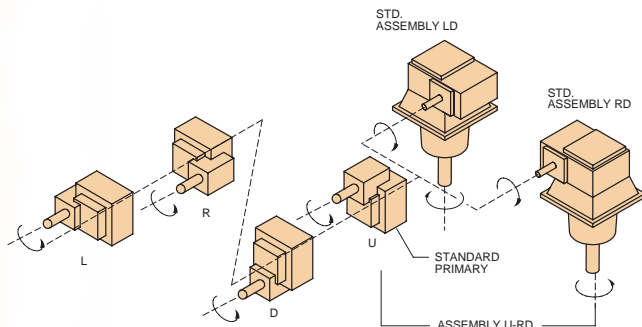

The input shaft may be driven in either direction.



MDLX - CDLX Helical/Worm Double Reduction Models

MDLX
Drop Bearing
Quill Input Adaptor
Solid Output Shaft
Flange Mount



CDLX
Drop Bearing
Coupled Input Adaptor
Solid Output Shaft
Flange Mount

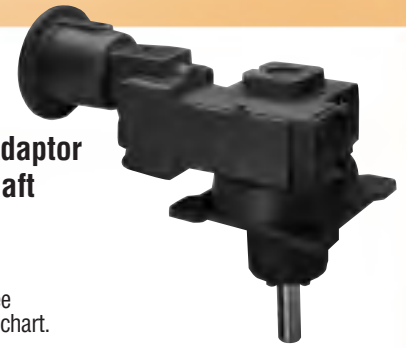

Couplings available, see page 106 for selection chart.

DIMENSIONS

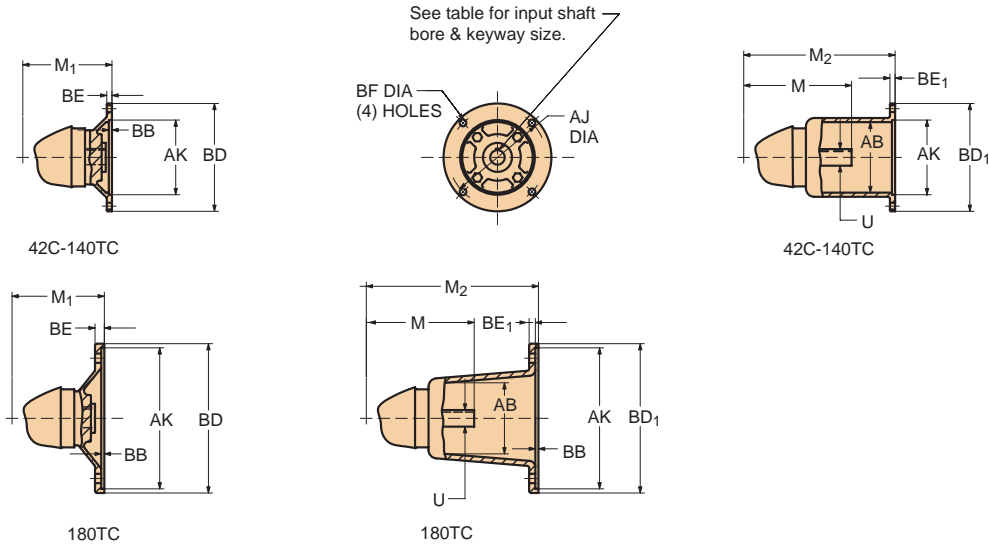

Size	QUILL INPUT ADAPTOR			COUPLED INPUT ADAPTOR											
	M ₁ 42C-48C	M ₁ 56C 140TC	M ₁ 180TC	42C-48C			56C-140TC			180TC			M	U	KEYWAY
				AB	M ₂	BE ₁	AB	M ₂	BE ₁	AB	M ₂	BE ₁			
E26	9.65	9.65	NA	2.13	13.15	.38	3.75	13.09	.38	NA			10.46	.750	3/16x3/32
E30	9.84	9.84	NA	2.13	13.34	.38	3.75	13.28	.38	NA			10.64	.750	3/16x3/32
E35	10.09	10.09	NA	2.13	13.59	.38	3.75	13.53	.38	NA			10.89	.750	3/16x3/32
E43	NA	12.25	12.25	NA			4.13	16.00	.38	4.25	17.06	.50	13.38	1.000	1/4x1/8

AVAILABLE SHAFT ARRANGEMENTS AND RELATIVE SHAFT ROTATIONS

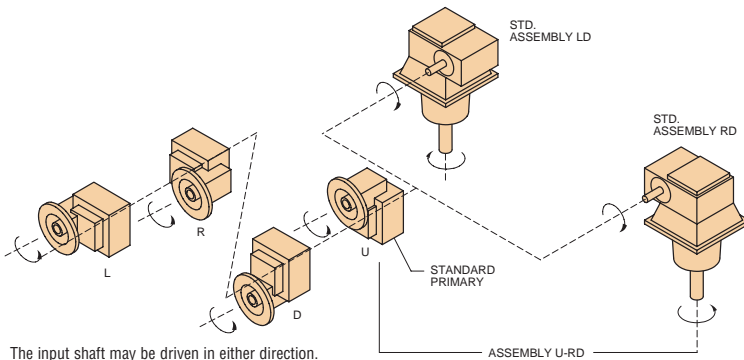

The input shaft may be driven in either direction.

INPUT ADAPT. DIM.	42C 48C	56C	140TC	180TC
AJ	3.75	5.88	5.88	7.25
AK	3.00	4.50	4.50	8.50
BB	.19	.19	.19	.19
BD	4.50	6.50	6.50	9.00
BD ₁	4.50	6.63	6.63	9.00
BE	.34	.31	.31	.38
BF	.281	.406	.406	.531
KEYWAY	1/8x1/16	3/16x3/32		1/4x1/8
BORE	^{+0.01} -.000	.5005*	.6255	.8755

* 42C adaptor has .3755 bore, 3/32 x 3/64 keyway



2D DRAWINGS & 3D MODELS
www.WINSMITH.com



XDSX Helical/Worm Double Reduction Model

XDSX
Universal
Solid Input Shaft
Hollow Output Shaft
Housing Mount



SHIPPING WEIGHTS (lb.) ♦					
MODEL	E24	E26	E30	E35	E43
XDSX	63	69	80	108	210
MDSX	66	72	83	146	219
CDSX	70	75	94	148	228

All motorized weights are for 48C to 140TC adaptor sizes. Add 10% for 180TC/210TC adaptor sizes.

♦Weights are approximate and include shipping carton.

DIMENSIONS

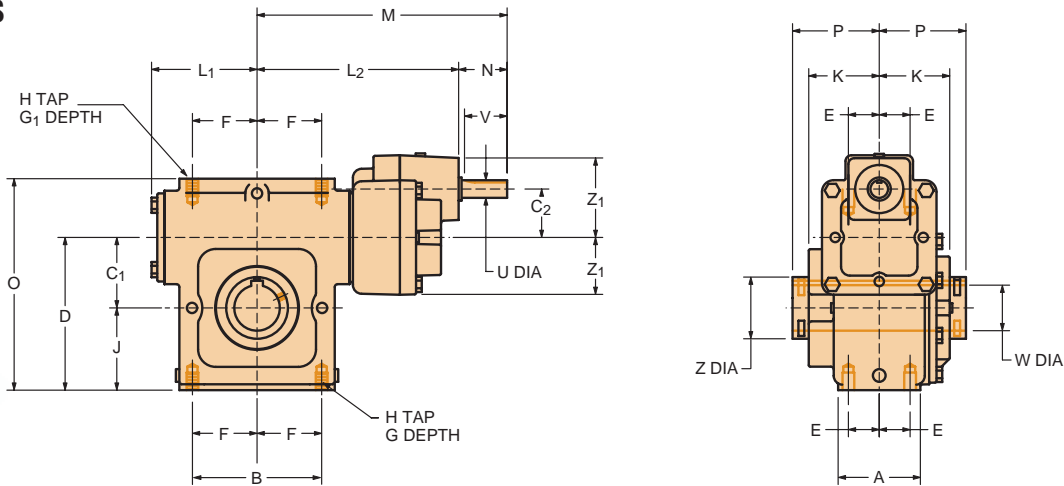

SPEED REDUCER DIMENSIONS (in.)

Size	A	B	C ₁	C ₂	D	E	F	G DEPTH	G ₁ DEPTH	H TAP	J	K	L ₁	L ₂	M	O	P	Z	Z ₁	Z ₂	INPUT SHAFT			
																					U*	N	V	KEYWAY
E24	3.13	5.38	2.375	2.060	5.25	1.13	2.19	.63	.57	1/2-13	2.88	2.75	4.50	8.39	10.46	7.25	3.44	2.25	3.50	2.44	.750	2.06	1.81	3/16x3/32
E26	3.13	5.88	2.625	2.060	5.75	1.13	2.44	.69	.69	1/2-13	3.13	2.81	4.50	8.39	10.46	7.88	3.50	2.50	3.50	2.44	.750	2.06	1.81	3/16x3/32
E30	3.50	6.62	3.000	2.060	6.50	1.31	2.75	.79	.75	1/2-13	3.50	3.00	4.63	8.58	10.64	9.00	3.69	2.63	3.50	2.44	.750	2.06	1.81	3/16x3/32
E35	3.75	7.69	3.500	2.060	7.50	1.31	3.25	1.00	1.00	5/8-11	4.00	3.38	5.06	8.83	10.89	10.13	4.13	2.87	3.50	2.44	.750	2.06	1.81	3/16x3/32
E43	4.38	8.75	4.250	3.200	8.63	1.63	3.75	1.00	1.00	5/8-11	4.38	3.63	5.88	10.63	13.38	11.50	4.44	3.88	5.02	3.38	1.000	2.75	2.38	1/4x1/8

* Shaft diameter tolerances +.000 -.001 Dimensions shown are for construction purposes only. Please contact Winsmith for certified dimension sheets.

HOLLOW OUTPUT SHAFT BORES

(S) Standard Bore (M) Machined to Size Bore (B) Bushing*
 *Bushing for use with standard bore only

W**	KEYWAY	E24	E26	E30	E35	E43
.625	5/8	3/16x3/32				
.750	3/4	3/16x3/32				
.875	7/8	3/16x3/32				
1.000	1	1/4x1/8	M/B	B		
1.125	1-1/8	1/4x1/8	M/B	B		
1.188	1-3/16	1/4x1/8	B	B		
1.250	1-1/4	1/4x1/8	M/B	M/B	M/B	M/B
1.375	1-3/8	5/16x5/32	B	B	B	
*1.438	1-7/16	3/8x3/16	M/B	B	B	M/B
1.500	1-1/2	3/8x3/16	S	M/B	M/B	M/B
1.625	1-5/8	3/8x3/16				S
1.688	1-11/16	3/8x3/16		S	M/B	S
1.750	1-3/4	3/8x3/16		B	B	B
1.875	1-7/8	1/2x1/4			S	B
*1.938	1-15/16	1/2x1/4		S	M/B	M/B
2.000	2	1/2x1/4			M/B	S
*2.188	2-3/16	1/2x1/4			S	M/B
2.250	2-1/4	1/2x1/4				B
2.438	2-7/16	5/8x5/16				M/B
2.500	2-1/2	5/8x5/16				B
2.750	2-3/4	5/8x5/16				S

** Bore tolerances +.000 +.002 Two puller slots opposed on all hollow output shafts
 * Bore size 1.438 on size E20: keyway is 3/8x1/8. * Bore size 1.938 on size E30: keyway is 1/2x3/16
 * Bore size 2.188 on size E35: keyway is 1/2x1/8. Contact Winsmith for other bore sizes

AVAILABLE SHAFT ARRANGEMENTS AND RELATIVE SHAFT ROTATIONS

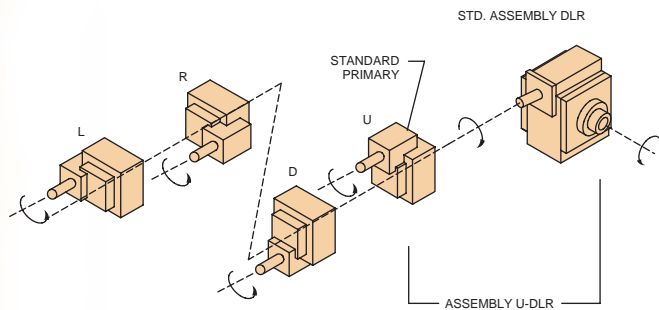

The input shaft may be driven in either direction.



MDSX - CDSX Helical/Worm Double Reduction Models

MDSX
 Universal
 Quill Input Adaptor
 Hollow Output Shaft
 Housing Mount



CDSX
 Universal
 Coupled Input Adaptor
 Hollow Output Shaft
 Housing Mount



Couplings available, see page 106 for selection chart.

DIMENSIONS

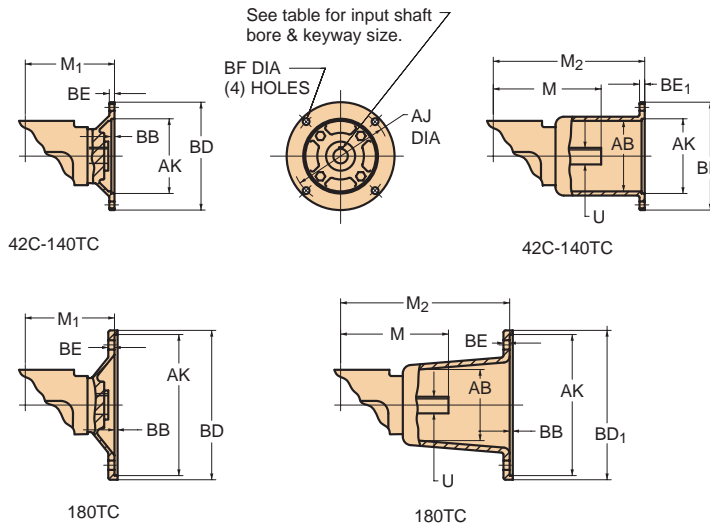

Size	QUILL INPUT ADAPTOR			COUPLED INPUT ADAPTOR											
	M ₁ 42C-48C	M ₁ 56C-140TC	M ₁ 180TC	42C-48TC			56C-140TC			180TC			M	U	KEYWAY
	AB	M ₂	BE ₁	AB	M ₂	BE ₁	AB	M ₂	BE ₁						
E24	9.65	9.65	NA	2.13	13.15	.38	3.75	13.09	.38	NA			10.46	.750	3/16 x 3/32
E26	9.65	9.65	NA	2.13	13.15	.38	3.75	13.09	.38	NA			10.46	.750	3/16 x 3/32
E30	9.84	9.84	NA	2.13	13.34	.38	3.75	13.28	.38	NA			10.64	.750	3/16 x 3/32
E35	10.09	10.09	NA	2.13	13.59	.38	3.75	13.53	.38	NA			10.89	.750	3/16 x 3/32
E43	NA	12.25	12.25	NA			4.13	16.00	.38	4.25	17.06	.50	13.38	1.000	3/16 x 3/32

AVAILABLE SHAFT ARRANGEMENTS AND RELATIVE SHAFT ROTATIONS

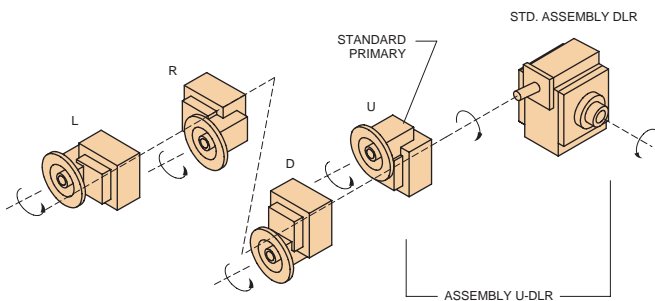

INPUT ADAPT. DIM.	42C 48C	56C	140TC	180TC
AJ	3.75	5.88	5.88	7.25
AK	3.00	4.50	4.50	8.50
BB	.19	.19	.19	.19
BD	4.50	6.50	6.50	9.00
BD ₁	4.50	6.63	6.63	9.00
BE	.34	.31	.31	.38
BF	.281	.406	.406	.531
KEYWAY	1/8 x 1/16	3/16 x 3/32		1/4 x 1/8
BORE +.001 -.000	.5005*	.6255	.8755	1.1255

* 42C adaptor has .3755 bore, 3/32 x 3/64 keyway

The input shaft may be driven in either direction.



2D DRAWINGS & 3D MODELS
 www.WINSMITH.com



XSTX - MSTX, XSBX - MSBX, XSJX - MSJX, Helical/Worm Double Reduction Models

SHIPPING WEIGHTS (lb.) ♦					
MODEL	E24	E26	E30	E35	E43
XSTX	68	75	88	118	224
MSTX	71	78	91	156	233
CSTX	75	81	102	158	242

All motorized weights are for 48C to 140TC adaptor sizes. Add 10% for 180TC/210TC adaptor sizes.

♦ Weights are approximate and include shipping carton.

SHIPPING WEIGHTS (lb.) ♦					
MODEL	E24	E26	E30	E35	E43
XSBX	68	75	88	118	224
MSBX	71	78	91	156	233
CSBX	75	81	102	158	242

All motorized weights are for 48C to 140TC adaptor sizes. Add 10% for 180TC/210TC adaptor sizes.

♦ Weights are approximate and include shipping carton.

SHIPPING WEIGHTS (lb.) ♦					
MODEL	E24	E26	E30	E35	E43
XSJX	69	75	88	117	221
MSJX	72	78	91	155	230
CSJX	76	81	102	157	239

All motorized weights are for 48C to 140TC adaptor sizes. Add 10% for 180TC/210TC adaptor sizes.

♦ Weights are approximate and include shipping carton.

Available Shaft Arrangements And Relative Shaft Rotations*

XSTX
Worm-On-Top
Solid Input Shaft
Hollow Output Shaft
Base Mount

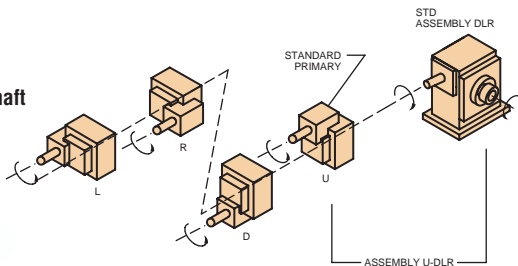

■ See page 54 for secondary stage dimensions

MSTX
Worm-On-Top
Quill Input Adaptor
Hollow Output Shaft
Base Mount

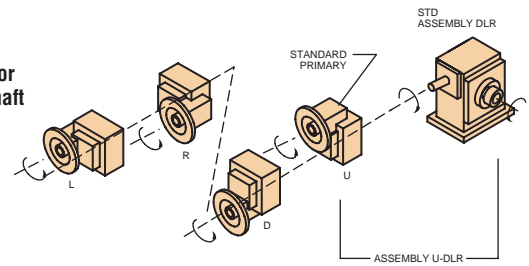

■ See page 54 for secondary stage dimensions

XSBX
Worm-On-Bottom
Solid Input Shaft
Hollow Output Shaft
Base Mount

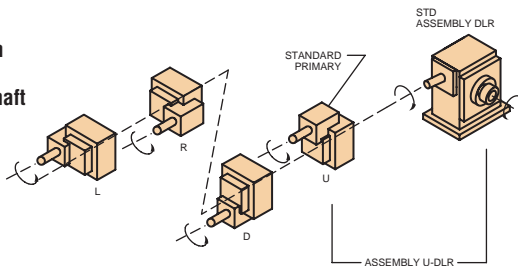

■ See page 56 for secondary stage dimensions

MSBX
Worm-On-Bottom
Quill Input Adaptor
Hollow Output Shaft
Base Mount

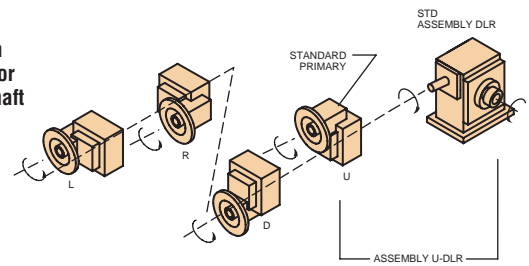

■ See page 56 for secondary stage dimensions

XSJX
"J" Vertical
Solid Input Shaft
Hollow Output Shaft
Bracket Mount

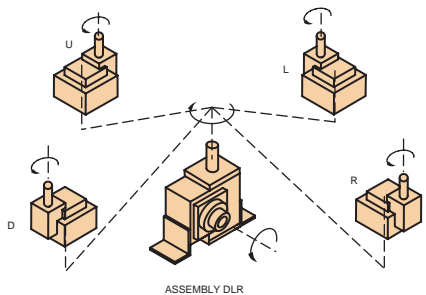

■ See page 58 for secondary stage dimensions

MSJX
"J" Vertical
Quill Input Adaptor
Hollow Output Shaft
Bracket Mount

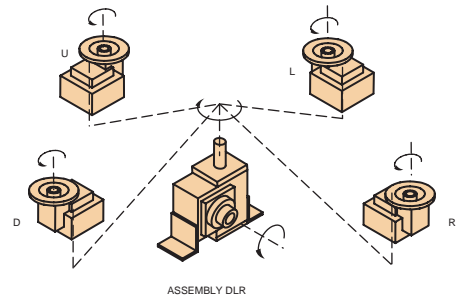

■ See page 58 for secondary stage dimensions

* The input shaft may be driven in either direction.

XSUX - MSUX, XSHX - MSHX, XSRX - MSRX, Helical/Worm Double Reduction Models

SHIPPING WEIGHTS (lb.) ♦					
MODEL	E24	E26	E30	E35	E43
XSUX	69	76	90	119	223
MSUX	72	79	93	157	232
CSUX	76	82	104	159	241

All motorized weights are for 48C to 140TC adaptor sizes. Add 10% for 180TC/210TC adaptor sizes.

♦ Weights are approximate and include shipping carton.

SHIPPING WEIGHTS (lb.) ♦					
MODEL	E24	E26	E30	E35	E43
XSHX	69	75	86	119	
MSHX	72	78	89	157	
CSHX	76	81	100	159	

All motorized weights are for 48C to 140TC adaptor sizes. Add 10% for 180TC/210TC adaptor sizes.

♦ Weights are approximate and include shipping carton.

SHIPPING WEIGHTS (lb.) ♦					
MODEL	E24	E26	E30	E35	E43
XSRX	64	69	88	129	223
MSRX	68	73	91	132	232
CSRX	77	82	101	135	241

All motorized weights are for 48C to 140TC adaptor sizes. Add 10% for 180TC/210TC adaptor sizes.

♦ Weights are approximate and include shipping carton.

Available Shaft Arrangements And Relative Shaft Rotations*

XSUX "U" Flange Solid Input Shaft Hollow Output Shaft Bracket Mount

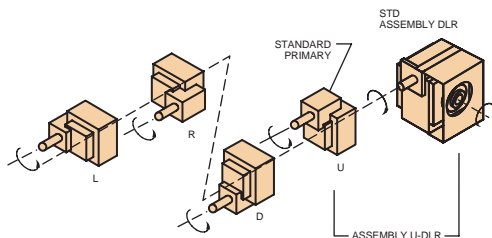

■ See page 60 for secondary stage dimensions

MSUX "U" Flange Quill Input Adaptor Hollow Output Shaft Bracket Mount

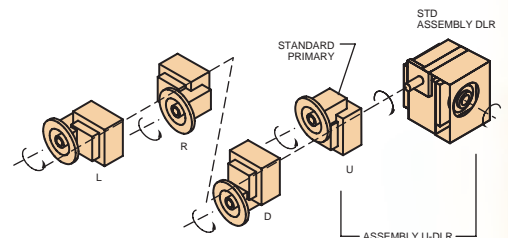

■ See page 60 for secondary stage dimensions

XSHX Hanger Solid Input Shaft Hollow Output Shaft Bracket Mount

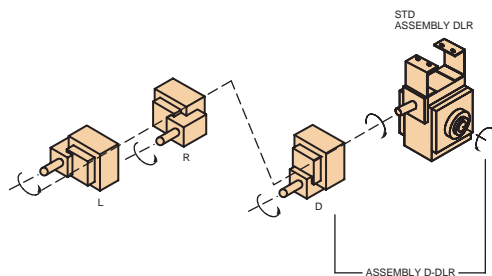

■ See page 62 for secondary stage dimensions

MSHX Hanger Quill Input Adaptor Hollow Output Shaft Bracket Mount

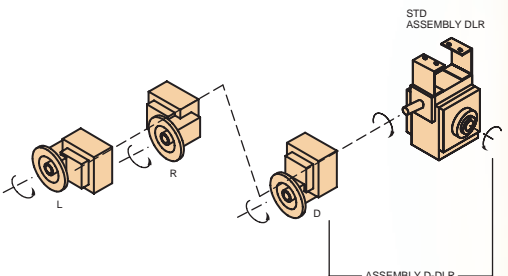

■ See page 62 for secondary stage dimensions

XSRX Torque Arm Solid Input Shaft Hollow Output Shaft Bracket Mount

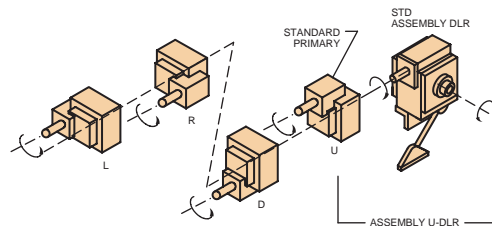

■ See page 64 for secondary stage dimensions

MSRX Torque Arm Quill Input Adaptor Hollow Output Shaft Bracket Mount

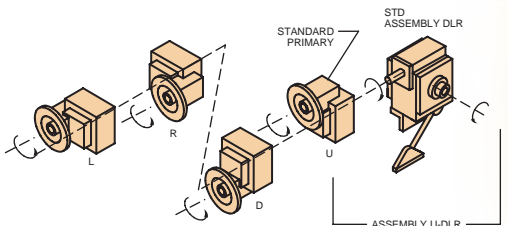

■ See page 64 for secondary stage dimensions

* The input shaft may be driven in either direction.



XSFX Helical/Worm Double Reduction Model

XSFX
Flange
Solid Input Shaft
Hollow Output Shaft
Flange Mount

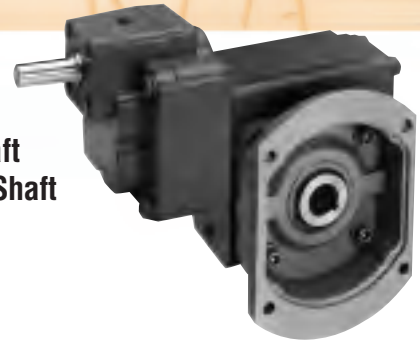

SHIPPING WEIGHTS (lb.) ♦					
MODEL	E24	E26	E30	E35	E43
XSFX	66	71	88	118	227
MFSFX	70	74	93	124	238
CSFX	73	81	98	138	245

All motorized weights are for 48C to 140TC adaptor sizes. Add 10% for 180TC/210TC adaptor sizes.

♦Weights are approximate and include shipping carton.

DIMENSIONS

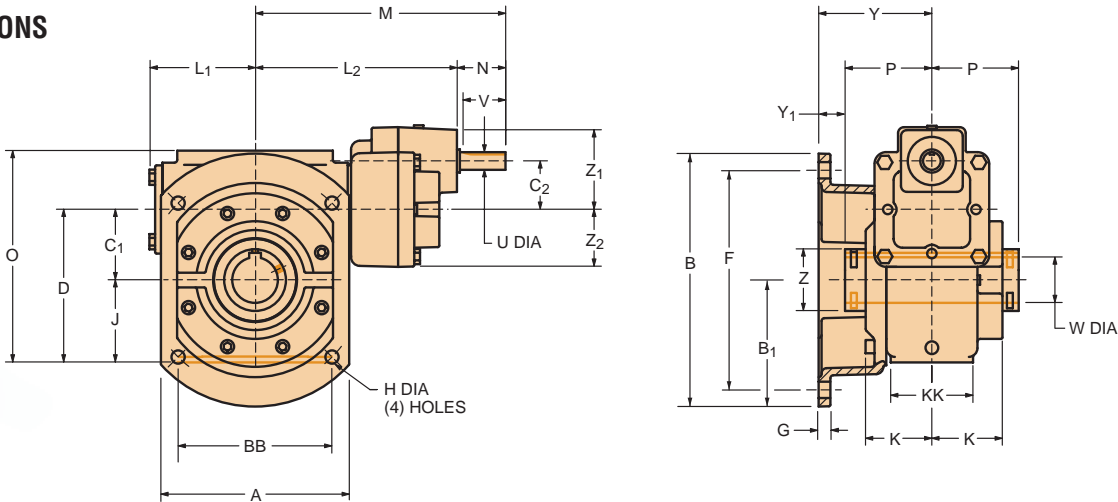

SPEED REDUCER DIMENSIONS (in.)

Size	A	B	B ₁	BB	C ₁	C ₂	D	F DIA	G	H DIA	J	K	KK	L ₁	L ₂	M	O	P	Y	Y ₁	Z	Z ₁	Z ₂	INPUT SHAFT			
																								U*	N	V	KEYWAY
E24	7.38	8.63	4.31	5.38	2.375	2.060	5.25	7.500	.38	.406	2.88	2.75	3.13	4.50	8.39	10.46	7.25	3.44	3.50	.06	2.25	3.50	2.44	.750	2.06	1.81	3/16x3/32
E26	7.75	9.13	4.56	5.88	2.625	2.060	5.75	8.000	.38	.406	3.13	2.81	3.13	4.50	8.39	10.46	7.88	3.50	3.63	.13	2.50	3.50	2.44	.750	2.06	1.81	3/16x3/32
E30	8.00	10.75	5.38	6.62	3.000	2.060	6.50	9.250	.50	.563	3.50	3.00	3.50	4.63	8.58	10.64	9.00	3.69	5.00	1.31	2.63	3.50	2.44	.750	2.06	1.81	3/16x3/32
E35	9.00	11.00	5.50	7.69	3.500	2.060	7.50	10.000	.50	.563	3.75	3.38	3.75	5.06	8.83	10.89	10.13	4.13	5.00	.88	2.87	3.50	2.44	.750	2.06	1.81	3/16x3/32
E43	10.50	13.00	6.50	8.75	4.250	3.200	8.63	11.500	.63	.688	4.38	3.63	4.38	5.88	10.63	13.38	11.50	4.38	5.75	1.38	3.88	5.02	3.38	1.000	2.75	2.38	1/4x1/8

* Shaft diameter tolerances +.000 -.001 Dimensions shown are for construction purposes only. Please contact Winsmith for certified dimension sheets.

AVAILABLE SHAFT ARRANGEMENTS AND RELATIVE SHAFT ROTATIONS

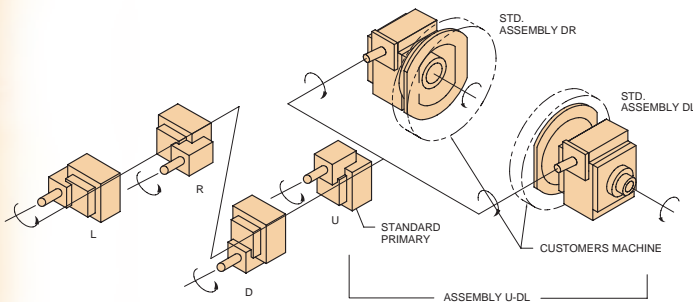

The input shaft may be driven in either direction.

HOLLOW OUTPUT SHAFT BORES

(S) Standard Bore (M) Machined to Size Bore (B) Bushing*
 *Bushing for use with standard bore only

W**	KEYWAY	E24	E26	E30	E35	E43
.625	5/8	3/16x3/32				
.750	3/4	3/16x3/32				
.875	7/8	3/16x3/32				
1.000	1	1/4x1/8	M/B	B		
1.125	1-1/8	1/4x1/8	M/B	B		
1.188	1-3/16	1/4x1/8	B	B		
1.250	1-1/4	1/4x1/8	M/B	M/B	M/B	M/B
1.375	1-3/8	5/16x3/32	B	B	B	
*1.438	1-7/16	3/8x3/16	M/B	B	B	M/B
1.500	1-1/2	3/8x3/16	S	M/B	M/B	M/B
1.625	1-5/8	3/8x3/16				S
1.688	1-11/16	3/8x3/16		S	M/B	S
1.750	1-3/4	3/8x3/16		B	B	B
1.875	1-7/8	1/2x1/4			S	B
*1.938	1-15/16	1/2x1/4		S	M/B	M/B
2.000	2	1/2x1/4			M/B	S
*2.188	2-3/16	1/2x1/4			S	M/B
2.250	2-1/4	1/2x1/4				B
2.438	2-7/16	5/8x5/16				M/B
2.500	2-1/2	5/8x5/16				B
2.750	2-3/4	5/8x5/16				S

** Bore tolerances +.000 +.002 Two puller slots opposed on all hollow output shafts

* Bore size 1.438 on size E20: keyway is 3/8x1/8. * Bore size 1.938 on size E30: keyway is 1/2x3/16

* Bore size 2.188 on size E35: keyway is 1/2x1/8. Contact Winsmith for other bore sizes



MSFX - CSFX Helical/Worm Double Reduction Models

MSFX
 Flange
 Quill Input Adaptor
 Hollow Output Shaft
 Flange Mount



CSFX
 Flange
 Coupled Input Adaptor
 Hollow Output Shaft
 Flange Mount



Couplings available, see page 106 for selection chart.

DIMENSIONS

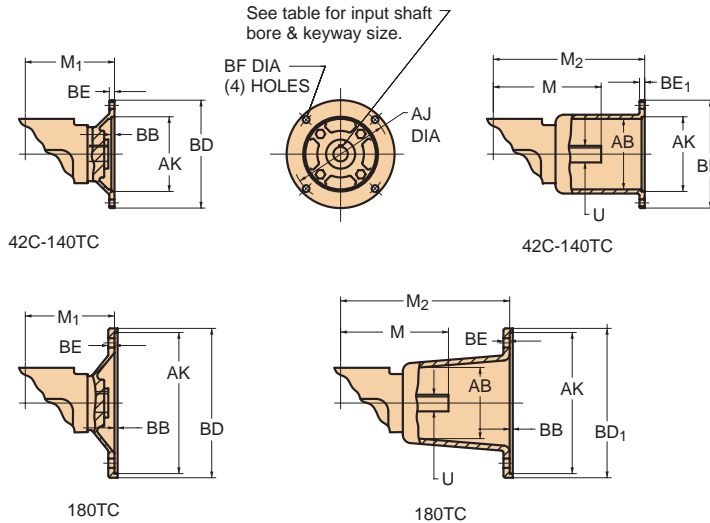

Size	QUILL INPUT ADAPTOR			COUPLED INPUT ADAPTOR											
	M ₁ 42C-48TC	M ₁ 56C-140TC	M ₁ 180TC	42C-48TC			56C-140TC			180TC			M	U	KEYWAY
				AB	M ₂	BE ₁	AB	M ₂	BE ₁	AB	M ₂	BE ₁			
E24	9.65	9.65	NA	2.13	13.15	.38	3.75	13.09	.38	NA			10.46	.750	3/16x3/32
E26	9.65	9.65	NA	2.13	13.15	.38	3.75	13.09	.38	NA			10.46	.750	3/16x3/32
E30	9.84	9.84	NA	2.13	13.34	.38	3.75	13.28	.38	NA			10.64	.750	3/16x3/32
E35	10.09	10.09	NA	2.13	13.59	.38	3.75	13.53	.38	NA			10.89	.750	3/16x3/32
E43	NA	12.25	12.25	NA			4.13	16.00	.38	4.25	17.06	.50	13.38	1.000	1/4x1/8

AVAILABLE SHAFT ARRANGEMENTS AND RELATIVE SHAFT ROTATIONS

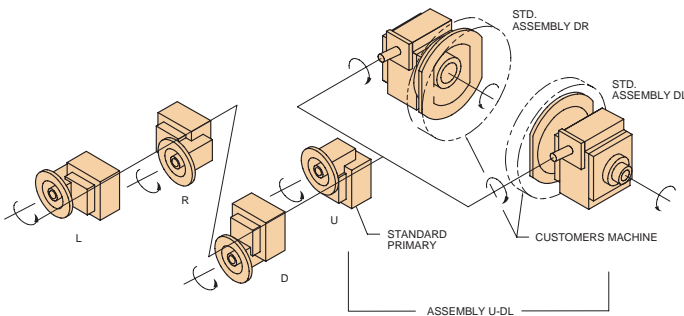

The input shaft may be driven in either direction.

INPUT ADAPT. DIM.	42C 48C	56C	140TC	180TC
AJ	3.75	5.88	5.88	7.25
AK	3.00	4.50	4.50	8.50
BB	.19	.19	.19	.19
BD	4.50	6.50	6.50	9.00
BD ₁	4.50	6.63	6.63	9.00
BE	.34	.31	.31	.38
BF	.281	.406	.406	.531
KEYWAY	1/8x1/16	3/16x3/32		1/4x1/8
BORE +.001 -.000	.5005*	.6255	.8755	1.1255

* 42C adaptor has .3755 bore, 3/32 x 3/64 keyway



2D DRAWINGS & 3D MODELS
 www.WINSMITH.com



Worm/Worm Double Reduction Models Quick Select



XDND

Universal
Solid Input Shaft
Solid Output Shaft
Housing Mount

See Page 90



MDND

Universal
Quill Input Adaptor
Solid Output Shaft
Housing Mount

See Page 91



CDND

Universal
Coupled Input Adaptor
Solid Output Shaft
Housing Mount

See Page 91



XDTD

Worm-On-Top
Solid Input Solid
Solid Output Solid
Base Mount

See Page 92



MDTD

Worm-On-Top
Quill Input Adaptor
Solid Output Shaft
Base Mount

See Page 92



CDTD

Worm-On-Top
Coupled Input Adaptor
Solid Output Shaft
Base Mount

See Page 92

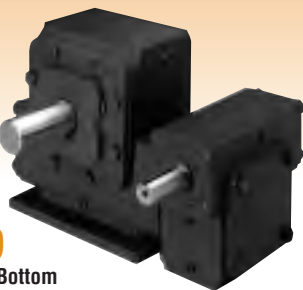

XDBD

Worm-On-Bottom
Solid Input Shaft
Solid Output Shaft
Base Mount

See Page 92

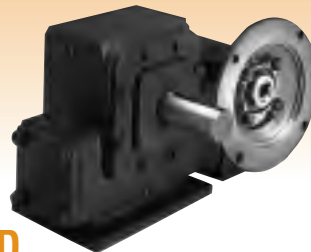

MDBD

Worm-On-Bottom
Quill Input Adaptor
Solid Output Shaft
Base Mount

See Page 92



CDBD

Worm-On-Bottom
Coupled Input Adaptor
Solid Output Shaft
Base Mount

See Page 92

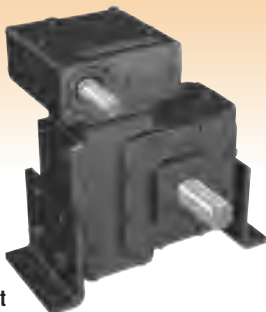

XDJD

"J" Vertical
Solid Input Shaft
Solid Output Shaft
Bracket Mount

See Page 93



MDJD

"J" Vertical
Quill Input Adaptor
Solid Output Shaft
Bracket Mount

See Page 93



CDJD

"J" Vertical
Coupled Input Adaptor
Solid Output Shaft
Bracket Mount

See Page 93

Worm/Worm Double Reduction Models Quick Select



XDUD
 "U" Flange
 Solid Input Shaft
 Solid Output Shaft
 Bracket Mount
 See Page 93

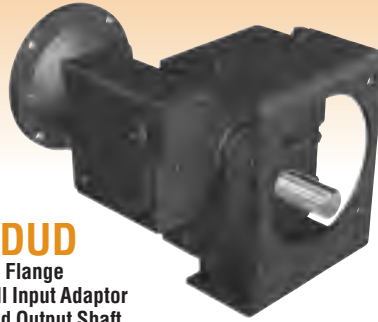

MDUD
 "U" Flange
 Quill Input Adaptor
 Solid Output Shaft
 Bracket Mount
 See Page 93



CDUD
 "U" Flange
 Coupled Input Adaptor
 Solid Output Shaft
 Bracket Mount
 See Page 93

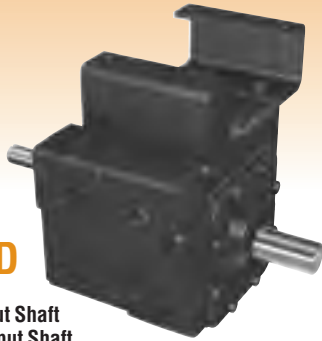

XDHD
 Hanger
 Solid Input Shaft
 Solid Output Shaft
 Bracket Mount
 See Page 93



MDHD
 Hanger
 Quill Input Adaptor
 Solid Output Shaft
 Bracket Mount
 See Page 93

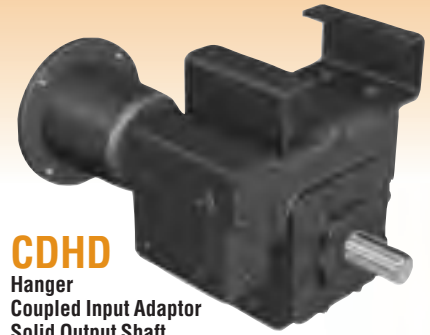

CDHD
 Hanger
 Coupled Input Adaptor
 Solid Output Shaft
 Bracket Mount
 See Page 93



XDVD
 Vertical
 Solid Input Shaft
 Solid Output Shaft
 Flange Mount
 See Page 94



MDVD
 Vertical
 Quill Input Adaptor
 Solid Output Shaft
 Flange Mount
 See Page 95

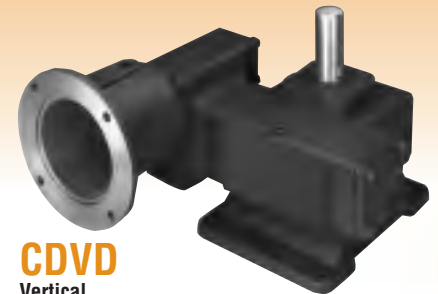

CDVD
 Vertical
 Coupled Input Adaptor
 Solid Output Shaft
 Flange Mount
 See Page 95

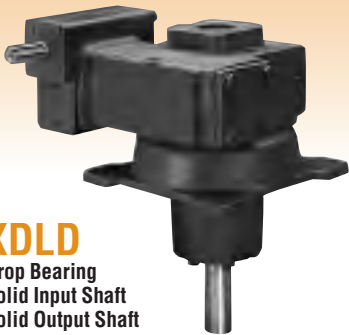

XDLD
 Drop Bearing
 Solid Input Shaft
 Solid Output Shaft
 Flange Mount
 See Page 96



MDLD
 Drop Bearing
 Quill Input Adaptor
 Solid Output Shaft
 Flange Mount
 See Page 97

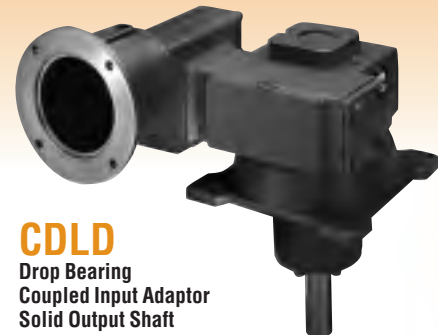

CDLD
 Drop Bearing
 Coupled Input Adaptor
 Solid Output Shaft
 Flange Mount
 See Page 97

Integral



2D DRAWINGS & 3D MODELS
www.WINSMITH.com



Worm/Worm Double Reduction Models Quick Select

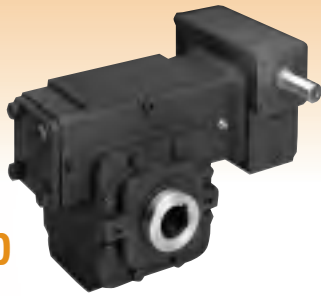

XDSD

Universal
Solid Input Shaft
Hollow Output Shaft
Housing Mount

See Page 98



MDSD

Universal
Quill Input Adaptor
Hollow Output Shaft
Housing Mount

See Page 99



CDSD

Universal
Coupled Input Adaptor
Hollow Output Shaft
Housing Mount

See Page 99



XSTD

Worm-On-Top
Solid Input Adaptor
Hollow Output Shaft
Base Mount

See Page 100

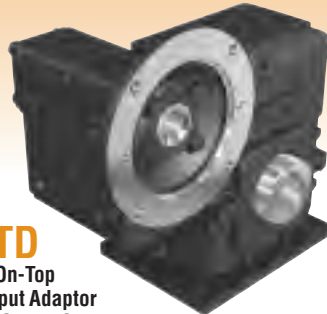

MSTD

Worm-On-Top
Quill Input Adaptor
Hollow Output Shaft
Base Mount

See Page 100



CSTD

Worm-On-Top
Coupled Input Adaptor
Hollow Output Shaft
Base Mount

See Page 100



XSBD

Worm-On-Bottom
Solid Input Shaft
Hollow Output Shaft
Base Mount

See Page 100

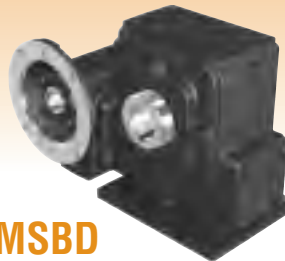

MSBD

Worm-On-Bottom
Quill Input Adaptor
Hollow Output Shaft
Base Mount

See Page 100



CSBD

Worm-On-Bottom
Coupled Input Adaptor
Hollow Output Shaft
Base Mount

See Page 100

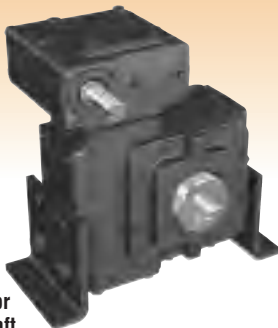

XSJD

"J" Vertical
Solid Input Adaptor
Hollow Output Shaft
Bracket Mount

See Page 100



MSJD

"J" Vertical
Quill Input Adaptor
Hollow Output Shaft
Bracket Mount

See Page 100



CSJD

"J" Vertical
Coupled Input Adaptor
Hollow Output Shaft
Bracket Mount

See Page 100

Worm/Worm Double Reduction Models Quick Select



XSUD

"U" Flange
Solid Input Shaft
Hollow Output Shaft
Bracket Mount

See Page 101

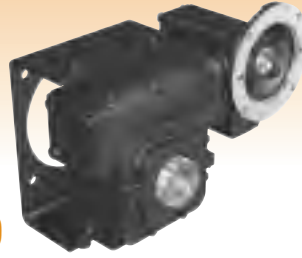

MSUD

"U" Flange
Quill Input Adaptor
Hollow Output Shaft
Bracket Mount

See Page 101

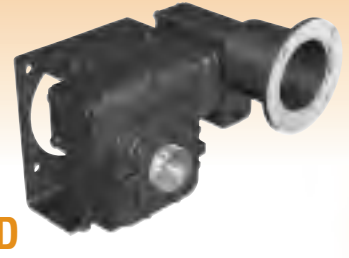

CSUD

"U" Flange
Coupled Input Adaptor
Hollow Output Shaft
Bracket Mount

See Page 101



XSHD

Hanger
Solid Input Shaft
Hollow Output Shaft
Bracket Mount

See Page 101



MSHD

Hanger
Quill Input Adaptor
Hollow Output Shaft
Bracket Mount

See Page 101



CSHD

Hanger
Coupled Input Adaptor
Hollow Output Shaft
Bracket Mount

See Page 101



XSRD

Torque Arm
Solid Input Shaft
Hollow Output Shaft
Bracket Mount

See Page 101



MSRD

Torque Arm
Quill Input Adaptor
Hollow Output Shaft
Bracket Mount

See Page 101



CSRD

Torque Arm
Coupled Input Adaptor
Hollow Output Shaft
Bracket Mount

See Page 101

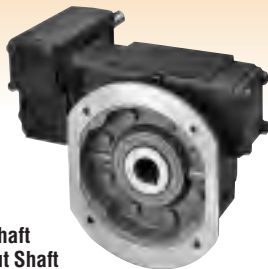

XSFD

Flange
Solid Input Shaft
Hollow Output Shaft
Flange Mount

See Page 102



MSFD

Flange
Quill Input Adaptor
Hollow Output Shaft
Flange Mount

See Page 103



CSFD

Flange
Coupled Input Adaptor
Hollow Output Shaft
Flange Mount

See Page 103



XDND Worm/Worm Double Reduction Model

XDND
Universal
Solid Input Shaft
Solid Output Shaft
Housing Mount



SHIPPING WEIGHTS (lb.) ♦							
MODEL	E17	E20	E24	E26	E30	E35	E43
XDND	29	31	55	62	74	96	163
MDND	31	33	58	65	77	99	167
CDND	34	39	63	70	81	104	173

All motorized weights are for 48C to 140TC adaptor sizes. Add 10% for 180TC/210TC adaptor sizes.

♦Weights are approximate and include shipping carton.

DIMENSIONS

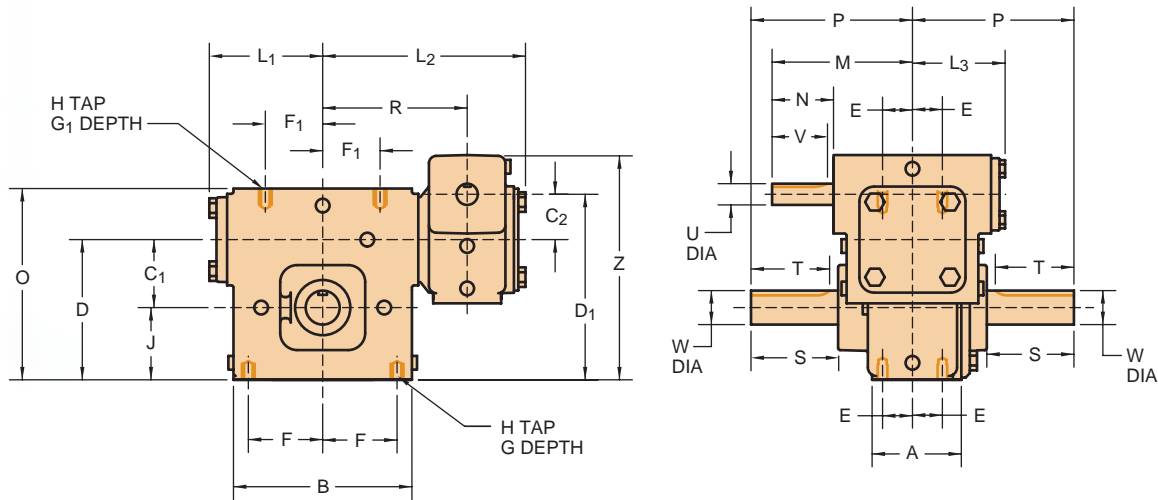

SPEED REDUCER DIMENSIONS (in.)

Size	A	B	C ₁	C ₂	D	D ₁	E	F	F ₁	G _{DEPTH}	G ₁ DEPTH	H TAP	J	L ₁	L ₂	L ₃	M	O	P	R	Z	INPUT SHAFT				OUTPUT SHAFT			
																						U*	N	V	KEYWAY	W*	S	T	KEYWAY
E17	2.38	4.63	1.750	1.333	3.88	5.21	.88	1.94	1.69	.63	.56	3/8-16	2.13	3.44	6.09	2.83	4.13	5.38	4.75	4.25	6.36	.625	1.81	1.63	3/16x3/32	1.000	2.56	2.31	1/4x1/8
E20	2.38	5.25	2.000	1.333	4.13	5.46	.88	2.19	1.69	.63	.56	3/8-16	2.13	3.44	6.09	2.83	4.13	5.63	4.75	4.25	6.61	.625	1.81	1.63	3/16x3/32	1.000	2.56	2.31	1/4x1/8
E24	3.13	5.38	2.375	1.750	5.25	7.00	1.13	2.19	2.19	.63	.57	1/2-13	2.88	4.50	7.65	3.44	4.75	7.25	5.50	5.75	8.35	.750	1.94	1.69	3/16x3/32	1.250	2.81	2.63	1/4x1/8
E26	3.13	5.88	2.625	1.750	5.75	7.50	1.13	2.44	2.44	.69	.69	1/2-13	3.13	4.50	7.65	3.44	4.75	7.88	5.50	5.75	8.85	.750	1.94	1.69	3/16x3/32	1.250	2.81	2.63	1/4x1/8
E30	3.50	6.62	3.000	2.000	6.50	8.50	1.31	2.75	2.75	.75	.75	1/2-13	3.50	4.63	8.15	3.44	5.00	9.00	5.88	6.25	9.85	.750	2.19	1.75	3/16x3/32	1.375	2.88	2.75	5/16x5/32
E35	3.75	7.69	3.500	2.000	7.50	9.50	1.31	3.25	3.25	1.00	1.00	5/8-11	4.00	5.06	8.40	3.44	5.00	10.13	7.00	6.50	10.85	.750	2.19	1.75	3/16x3/32	1.750	3.75	3.63	3/8x3/16
E43	4.38	8.75	4.250	2.625	8.63	11.25	1.63	3.75	3.75	1.00	1.00	5/8-11	4.38	5.88	10.02	4.50	6.50	11.50	8.00	7.56	13.40	1.000	2.75	2.63	1/4x1/8	2.000	4.38	4.19	1/2x1/4

* Shaft diameter tolerances +.000 -.001 Dimensions shown are for construction purposes only. Please contact Winsmith for certified dimension sheets.

AVAILABLE SHAFT ARRANGEMENTS AND RELATIVE SHAFT ROTATIONS

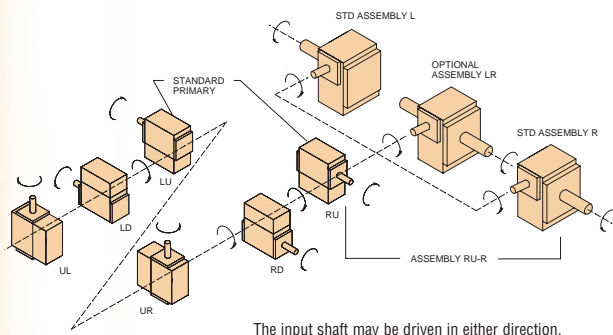

MDND - CDND Worm/Worm Double Reduction Models

MDND
 Universal
 Quill Input Adaptor
 Solid Output Shaft
 Housing Mount



CDND
 Universal
 Coupled Input Adaptor
 Solid Output Shaft
 Housing Mount



Couplings available, see page 106 for selection chart.

DIMENSIONS

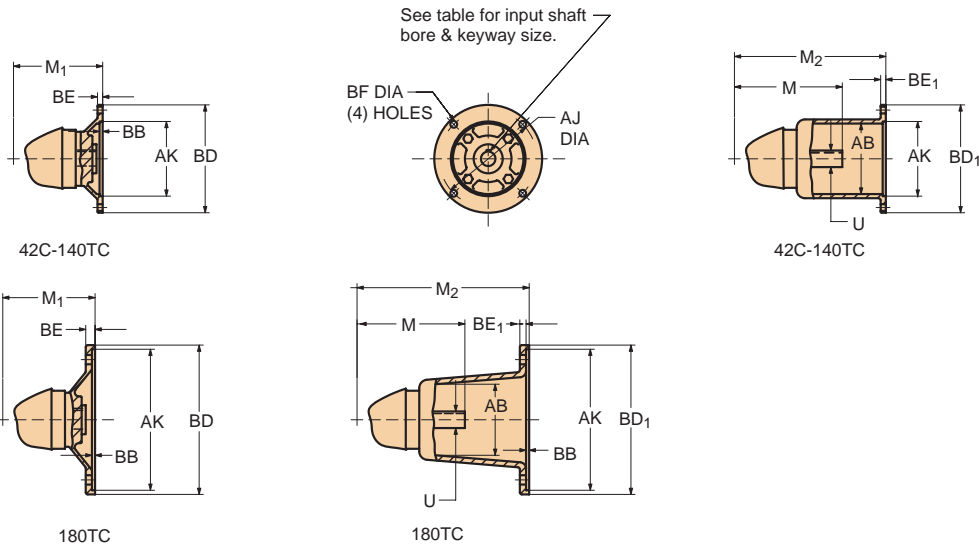

Size	QUILL INPUT ADAPTOR			COUPLED INPUT ADAPTOR									M	U	KEYWAY
	M ₁ 42C-48C	M ₁ 56C-140TC	M ₁ 180TC	42C-48C			56C-140TC			180TC					
	AB	M ₂	BE ₁	AB	M ₂	BE ₁	AB	M ₂	BE ₁						
E17	3.56	3.63*	NA	2.50	6.81	.38	3.00	6.75	.31	NA			4.13	.625	3/16x3/32
E20	3.56	3.63*	NA	2.50	6.81	.38	3.00	6.75	.31	NA			4.13	.625	3/16x3/32
E24	4.06	4.06	NA	2.50	7.56	.38	3.75	7.50	.38	3.75	8.44	.50	4.75	.750	3/16x3/32
E26	4.06	4.06	NA	2.50	7.56	.38	3.75	7.50	.38	3.75	8.44	.50	4.75	.750	3/16x3/32
E30	4.06	4.06	NA	2.50	7.56	.38	3.75	7.50	.38	3.75	8.44	.50	5.00	.750	3/16x3/32
E35	4.06	4.06	NA	2.50	7.56	.38	3.75	7.50	.38	3.75	8.44	.50	5.00	.750	3/16x3/32
E43	NA	5.38	5.38	NA			4.13	9.13	.38	4.25	10.19	.50	6.50	1.000	1/4x1/8

*56C adaptor only

AVAILABLE SHAFT ARRANGEMENTS AND RELATIVE SHAFT ROTATIONS

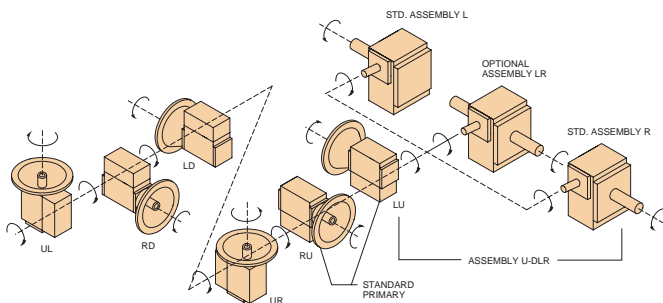

The input shaft may be driven in either direction.

INPUT ADAPT. DIM.	42C 48C	56C	140TC	180TC
AJ	3.75	5.88	5.88	7.25
AK	3.00	4.50	4.50	8.50
BB	.19	.19	.19	.19
BD	4.50	6.50	6.50	9.00
BD ₁	4.50	6.63	6.63	9.00
BE	.34	.31	.31	.38
BF	.281	.406	.406	.531
KEYWAY	1/8x1/16	3/16x3/32		1/4x1/8
BORE ^{+0.01} / _{-0.00}	.5005*	.6255	.8755	1.1255

*42C adaptor has .3755 bore, 3/32 x 3/64 keyway



2D DRAWINGS & 3D MODELS
 www.WINSMITH.com



XDTD - MDTD, XDBD - MDBD, Worm/Worm Double Reduction Models

MODEL	SHIPPING WEIGHTS (lb.) ♦						
	E17	E20	E24	E26	E30	E35	E43
XDTD	33	33	60	63	79	111	168
MDTD	36	37	63	66	88	121	193
CDTD	41	42	66	68	90	132	219

All motorized weights are for 48C to 140TC adaptor sizes. Add 10% for 180TC/210TC adaptor sizes.

♦ Weights are approximate and include shipping carton.

MODEL	SHIPPING WEIGHTS (lb.) ♦						
	E17	E20	E24	E26	E30	E35	E43
XDBD	32	33	57	58	84	101	196
MDBD	35	38	60	65	91	120	202
CDBD	38	41	64	70	95	122	206

All motorized weights are for 48C to 140TC adaptor sizes. Add 10% for 180TC/210TC adaptor sizes.

♦ Weights are approximate and include shipping carton.

Available Shaft Arrangements And Relative Shaft Rotations*

XDTD Worm-On-Top Solid Input Shaft Solid Output Shaft Base Mount

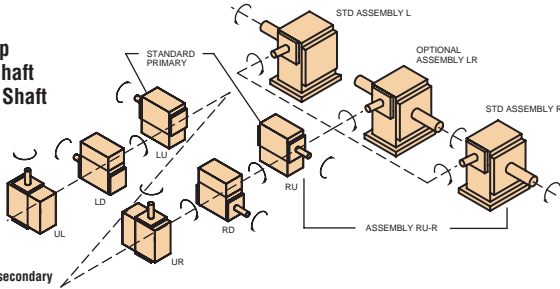

■ See page 38 for secondary stage dimensions

MDTD Worm-On-Top Quill Input Adaptor Solid Output Shaft Base Mount

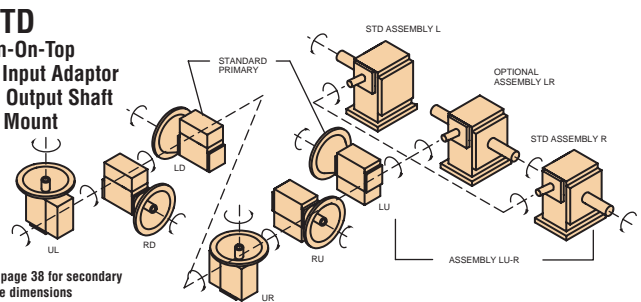

■ See page 38 for secondary stage dimensions

XDBD Worm-On-Bottom Solid Input Shaft Solid Output Shaft Base Mount

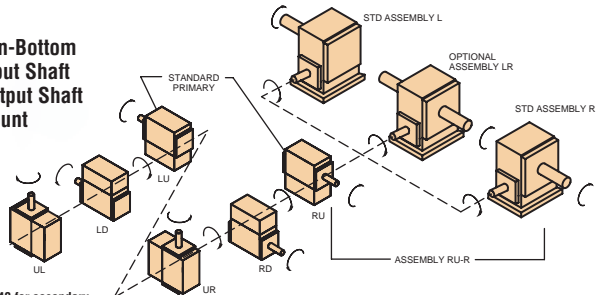

■ See page 40 for secondary stage dimensions

MDBD Worm-On-Bottom Quill Input Adaptor Solid Output Shaft Base Mount

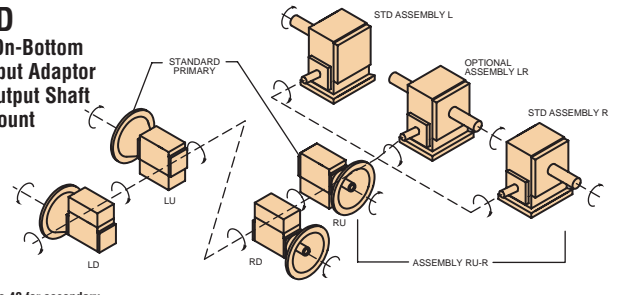

■ See page 40 for secondary stage dimensions

* The input shaft may be driven in either direction.

XDJJ - MDJJ, XDUD - MDUD, XDHD - MDHD, Worm/Worm Double Reduction Models

SHIPPING WEIGHTS (lb.) ♦							
MODEL	E17	E20	E24	E26	E30	E35	E43
XDJJ	32	36	61	68	82	105	174
MDJJ	34	38	64	71	85	108	178
CDJJ	37	44	69	76	89	113	184

All motorized weights are for 48C to 140TC adaptor sizes. Add 10% for 180TC/210TC adaptor sizes.

♦ Weights are approximate and include shipping carton.

SHIPPING WEIGHTS (lb.) ♦							
MODEL	E17	E20	E24	E26	E30	E35	E43
XDUD	33	37	61	69	84	107	176
MDUD	35	39	64	72	87	110	180
CDUD	38	45	69	77	91	115	186

All motorized weights are for 48C to 140TC adaptor sizes. Add 10% for 180TC/210TC adaptor sizes.

♦ Weights are approximate and include shipping carton.

SHIPPING WEIGHTS (lb.) ♦						
MODEL	E17	E20	E24	E26	E30	E35
XDHD	33	36	61	68	80	107
MDHD	35	38	64	71	83	110
CDHD	38	44	69	76	87	115

All motorized weights are for 48C to 140TC adaptor sizes. Add 10% for 180TC/210TC adaptor sizes.

♦ Weights are approximate and include shipping carton.

Available Shaft Arrangements And Relative Shaft Rotations*

XDJJ "J" Vertical Solid Input Shaft Solid Output Shaft Bracket Mount

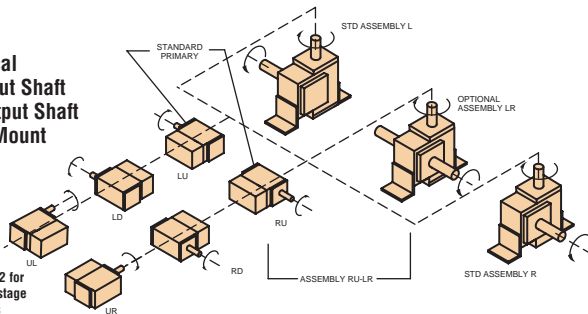

MDJJ "J" Vertical Quill Input Adaptor Solid Output Shaft Bracket Mount

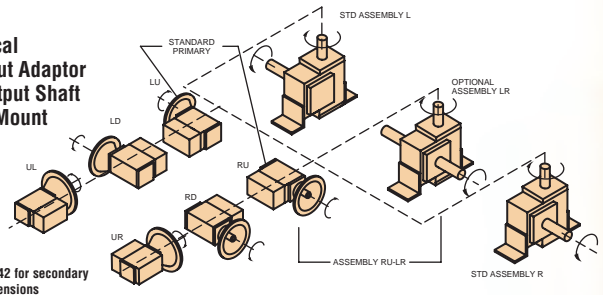

XDUD "U" Flange Solid Input Shaft Solid Output Shaft Bracket Mount

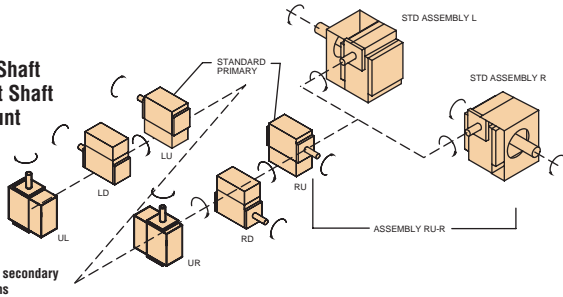

MDUD "U" Flange Quill Input Adaptor Solid Output Shaft Bracket Mount

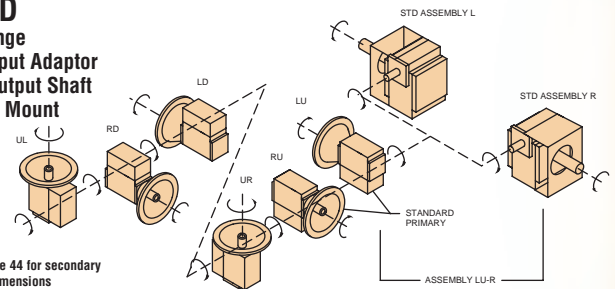

XDHD Hanger Solid Input Shaft Solid Output Shaft Bracket Mount

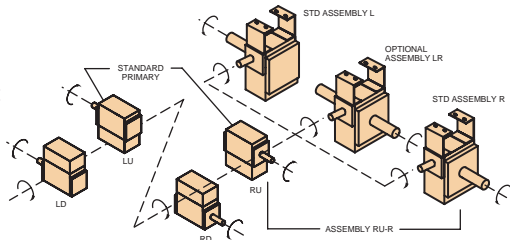

MDHD Hanger Quill Input Adaptor Solid Output Shaft Bracket Mount

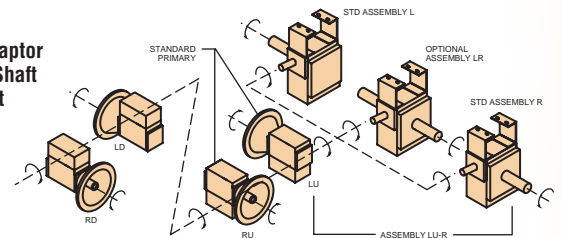

* The input shaft may be driven in either direction.



XDVD Worm/Worm Double Reduction Model

XDVD
Vertical
Solid Input Shaft
Solid Output Shaft
Flange Mount



SHIPPING WEIGHTS (lb.) ♦							
MODEL	E17	E20	E24	E26	E30	E35	E43
XDVD	33	34	65	63	79	112	200
MDVD	35	36	68	66	84	115	203
CDVD	38	41	72	71	88	120	208

All motorized weights are for 48C to 140TC adaptor sizes. Add 10% for 180TC/210TC adaptor sizes.

♦ Weights are approximate and include shipping carton.

DIMENSIONS

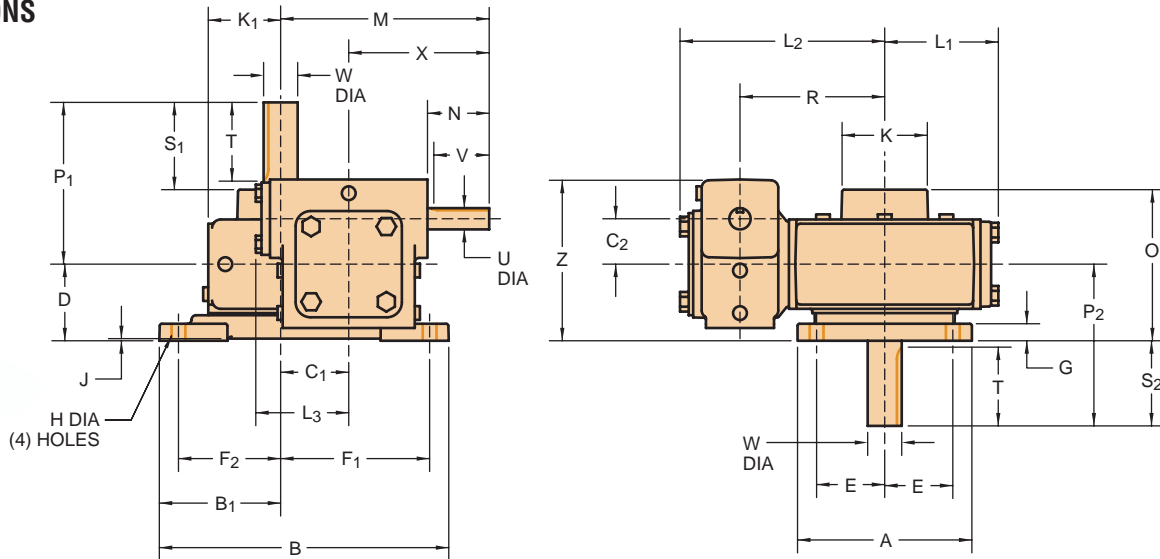

SPEED REDUCER DIMENSIONS (in.)

Size	A	B	B ₁	C ₁	C ₂	D	E	F ₁	F ₂	G	H	J	K	K ₁	L ₁	L ₂	L ₃	M	O	P ₁	P ₂	R	X	Z	INPUT SHAFT				OUTPUT SHAFT				
																									U*	N	V	KEYWAY	W*	S ₁	S ₂	T	KEYWAY
E17	5.31	7.76	3.19	1.750	1.333	2.25	2.00	4.00	2.63	.50	.406	.06	2.50	2.13	3.44	6.09	2.83	5.88	4.44	4.75	4.75	4.25	4.12	4.74	.625	1.81	1.63	3/16x3/32	1000	2.56	2.50	2.31	1/4x1/8
E20	5.31	8.50	3.56	2.000	1.333	2.25	2.00	4.38	3.00	.50	.406	.06	2.50	2.13	3.44	6.09	2.83	6.13	4.44	4.75	4.75	4.25	4.12	4.74	.625	1.81	1.63	3/16x3/32	1000	2.56	2.50	2.31	1/4x1/8
E24	6.88	8.88	3.44	2.375	1.750	3.50	2.88	4.88	2.88	.50	.406	.13	3.25	2.88	4.50	7.65	3.44	7.13	6.13	5.75	6.38	5.75	4.75	6.60	.750	1.94	1.69	3/16x3/32	1250	3.12	2.88	2.75	1/4x1/8
E26	6.88	9.44	3.63	2.625	1.750	3.63	2.88	5.25	2.88	.50	.406	.13	3.50	3.13	4.50	7.65	3.44	7.38	6.26	5.63	6.38	5.75	4.75	6.73	.750	1.94	1.69	3/16x3/32	1250	3.00	2.75	2.75	1/4x1/8
E30	8.88	10.63	4.25	3.000	2.000	3.75	3.81	5.75	3.63	.63	.563	.13	3.50	3.50	4.63	8.15	3.44	8.00	6.75	6.19	6.75	6.25	5.00	7.10	.750	2.19	1.75	3/16x3/32	1375	3.19	3.00	3.06	5/16x5/32
E35	9.75	11.50	5.00	3.500	2.000	3.75	4.25	5.88	4.38	.63	.563	.13	4.13	4.00	5.06	8.40	3.44	8.50	7.00	7.00	7.00	6.50	5.00	7.10	.750	2.19	1.75	3/16x3/32	1750	3.75	3.25	3.63	3/8x3/16
E43	9.63	11.00	4.81	4.250	2.625	4.75	4.13	5.50	4.13	.63	.563	.13	4.75	4.38	5.88	10.02	4.50	10.75	8.38	8.00	8.00	7.56	6.50	9.53	1.000	2.75	2.63	1/4x1/8	2000	4.38	3.25	4.19	1/2x1/4

* Shaft diameter tolerances +.000 - .001 Dimensions shown are for construction purposes only. Please contact Winsmith for certified dimension sheets.

AVAILABLE SHAFT ARRANGEMENTS AND RELATIVE SHAFT ROTATIONS

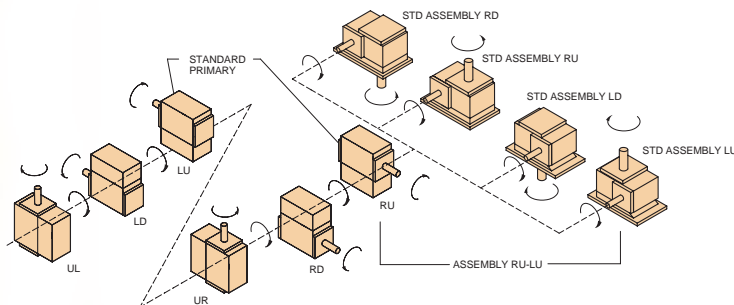

The input shaft may be driven in either direction.



MDVD - CDVD Worm/Worm Double Reduction Models

MDVD
Vertical
Quill Input Adaptor
Solid Output Shaft
Flange Mount



CDVD
Vertical
Coupled Input Adaptor
Solid Output Shaft
Flange Mount

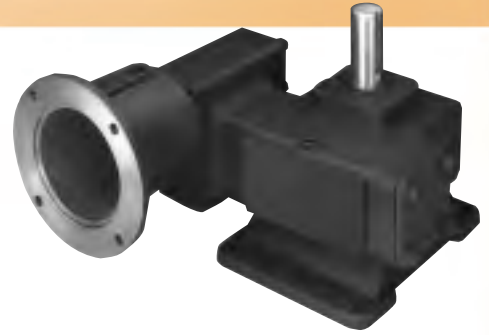

Couplings available, see page 106 for selection chart.

DIMENSIONS

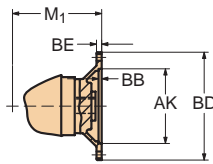

42C-140TC

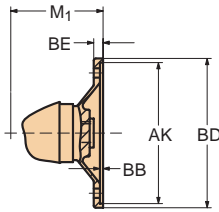

180TC

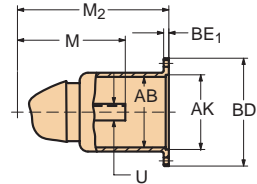
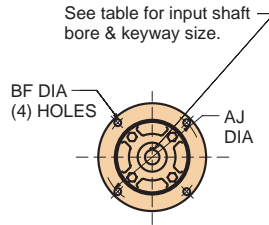

42C-140TC

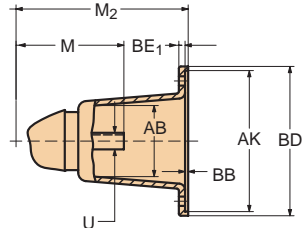

180TC

Size	QUILL INPUT ADAPTOR			COUPLED INPUT ADAPTOR									M	U	KEYWAY
	M ₁ 42C-48C	M ₁ 56C-140TC	M ₁ 180TC	42C-48C			56C-140TC			180TC					
				AB	M ₂	BE ₁	AB	M ₂	BE ₁	AB	M ₂	BE ₁			
E17	3.56	3.63*	NA	2.50	6.81	.38	3.00	6.75	.31	NA			4.13	.625	3/16 x 3/32
E20	3.56	3.63*	NA	2.50	6.81	.38	3.00	6.75	.31	NA			4.13	.625	3/16 x 3/32
E24	4.06	4.06	NA	2.50	7.56	.38	3.75	7.50	.38	3.75	8.44	.50	4.75	.750	3/16 x 3/32
E26	4.06	4.06	NA	2.50	7.56	.38	3.75	7.50	.38	3.75	8.44	.50	4.75	.750	3/16 x 3/32
E30	4.06	4.06	NA	2.50	7.56	.38	3.75	7.50	.38	3.75	8.44	.50	5.00	.750	3/16 x 3/32
E35	4.06	4.06	NA	2.50	7.56	.38	3.75	7.50	.38	3.75	8.44	.50	5.00	.750	3/16 x 3/32
E43	NA	5.38	5.38	NA			4.13	9.13	.38	4.25	10.19	.50	6.50	1.000	1/4 x 1/8

*56C adaptor only

AVAILABLE SHAFT ARRANGEMENTS AND RELATIVE SHAFT ROTATIONS

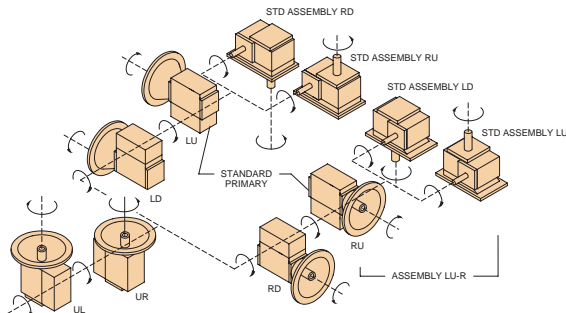

The input shaft may be driven in either direction.

INPUT ADAPT. DIM.	42C 48C	56C	140TC	180TC
AJ	3.75	5.88	5.88	7.25
AK	3.00	4.50	4.50	8.50
BB	.19	.19	.19	.19
BD	4.50	6.50	6.50	9.00
BD ₁	4.50	6.63	6.63	9.00
BE	.34	.31	.31	.38
BF	.281	.406	.406	.531
KEYWAY	1/8 x 1/16	3/16 x 3/32		1/4 x 1/8
BORE +.001 -.000	.5005*	.6255	.8755	1.1255

*42C adaptor has .3755 bore, 3/32 x 3/64 keyway



2D DRAWINGS & 3D MODELS
www.WINSMITH.com



XDLW Worm/Worm Double Reduction Model

SHIPPING WEIGHTS (lb.) ♦				
MODEL	E26	E30	E35	E43
XDLW	76	109	141	206
MDLD	79	112	144	210
CDLD	83	116	146	215

All motorized weights are for 48C to 140TC adaptor sizes. Add 10% for 180TC/210TC adaptor sizes.

♦Weights are approximate and include shipping carton.

XDLW
Drop Bearing
Solid Input Shaft
Solid Output Shaft
Flange Mount



DIMENSIONS

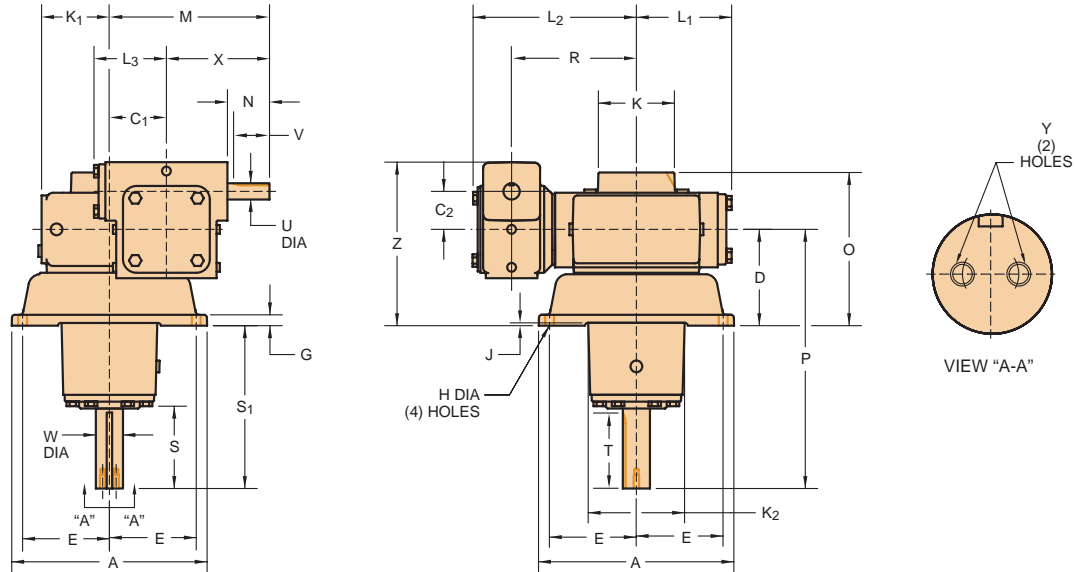

SPEED REDUCER DIMENSIONS (in.)

Size	A	C ₁	C ₂	D	E	G	H	J	K	K ₁	K ₂	L ₁	L ₂	L ₃	M	O	P	R	X	Z	Y DIMENSIONS			INPUT SHAFT			OUTPUT SHAFT					
																					TAP	DEPTH	BOLT CIRCLE	U*	N	V	KEYWAY	W*	S	S ₁	T	KEYWAY
E26	9.00	2.625	1.750	4.44	4.00	.50	.406	.13	3.50	3.13	4.44	4.50	7.65	3.44	7.38	7.06	11.94	5.75	4.75	7.54	.25-20	.44	.625	.750	1.94	1.69	3/16 x 3/32	1.250	3.68	7.50	3.50	1/4x1/8
E30	9.75	3.000	2.000	5.31	4.13	.63	.563	.13	3.50	3.50	5.19	4.63	8.15	3.44	8.00	8.31	14.81	6.25	5.00	8.66	.31-18	.50	.750	.750	2.19	1.75	3/16 x 3/32	1.438	4.63	9.50	4.56	3/16 x 3/32
E35	12.00	3.500	2.000	5.38	5.25	.75	.563	.13	4.13	4.00	5.38	5.06	8.40	3.44	8.50	8.63	14.88	6.50	5.00	8.73	.31-18	.50	.750	.750	2.19	1.75	3/16 x 3/32	1.625	4.75	9.50	4.56	3/8x3/16
E43	14.00	4.250	2.625	6.00	6.00	.88	.688	.13	4.75	4.38	5.94	5.88	10.02	4.50	10.75	9.63	16.50	7.56	6.50	10.78	.38-16	1.00	1.000	1.000	2.75	2.63	1/4x1/8	1.688	5.61	10.50	5.44	3/8x3/16

* Shaft diameter tolerances +.000 - .001 Dimensions shown are for construction purposes only. Please contact Winsmith for certified dimension sheets.

AVAILABLE SHAFT ARRANGEMENTS AND RELATIVE SHAFT ROTATIONS

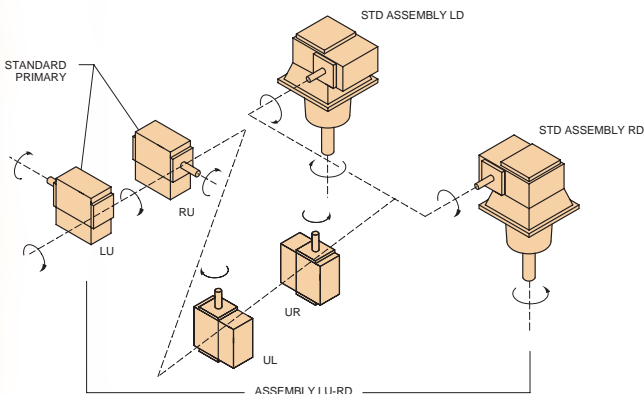

The input shaft may be driven in either direction.



MDLD - CDLD Worm/Worm Double Reduction Models

MDLD
Drop Bearing
Quill Input Adaptor
Solid Output Shaft
Flange Mount



CDLD
Drop Bearing
Coupled Input Adaptor
Solid Output Shaft
Flange Mount



Couplings available, see page 106 for selection chart.

DIMENSIONS

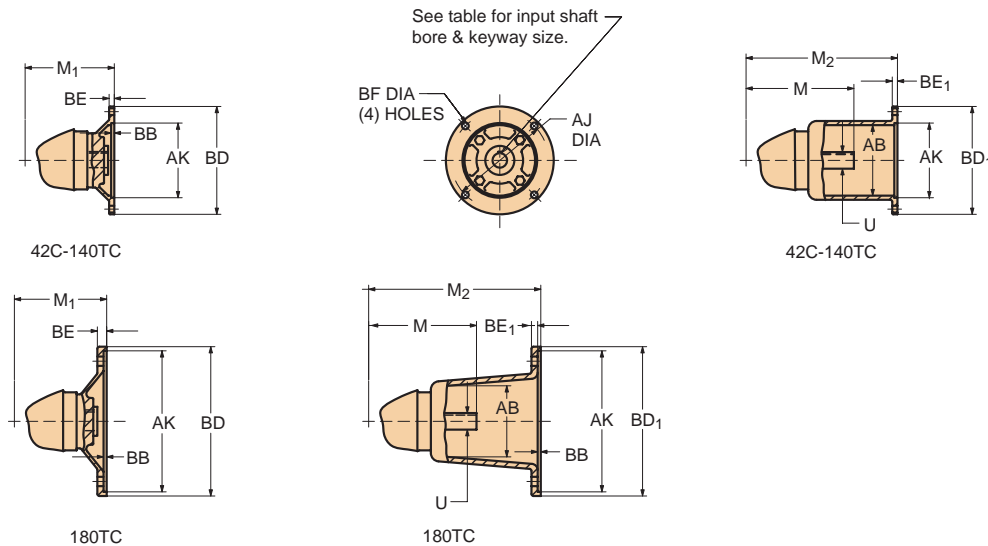

Size	QUILL INPUT ADAPTOR			COUPLED INPUT ADAPTOR											
	M ₁ 42C-48C	M ₁ 56C-140TC	M ₁ 180TC	42C-48C			56C-140TC			180TC			M	U	KEYWAY
				AB	M ₂	BE ₁	AB	M ₂	BE ₁	AB	M ₂	BE ₁			
E26	4.06	4.06	NA	2.50	7.56	.38	3.75	7.50	.38	3.75	8.44	.50	4.75	.750	3/16x3/32
E30	4.06	4.06	NA	2.50	7.56	.38	3.75	7.50	.38	3.75	8.44	.50	5.00	.750	3/16x3/32
E35	4.06	4.06	NA	2.50	7.56	.38	3.75	7.50	.38	3.75	8.44	.50	5.00	.750	3/16x3/32
E43	NA	5.38	5.38	NA			4.13	9.13	.38	4.25	10.19	.50	6.50	1.000	1/4x1/8

AVAILABLE SHAFT ARRANGEMENTS AND RELATIVE SHAFT ROTATIONS

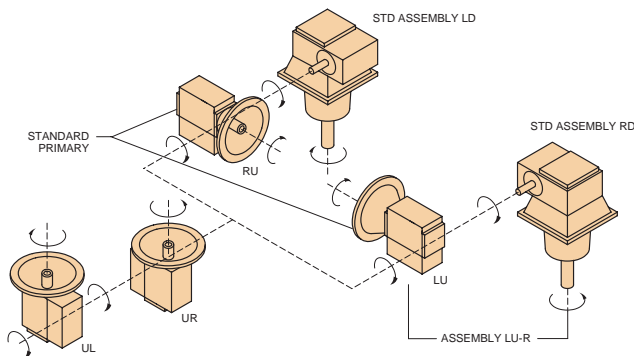

INPUT ADAPT. DIM.	42C-48C	56C	140TC	180TC
AJ	3.75	5.88	5.88	7.25
AK	3.00	4.50	4.50	8.50
BB	.19	.19	.19	.19
BD	4.50	6.50	6.50	9.00
BD ₁	4.50	6.63	6.63	9.00
BE	.34	.31	.31	.38
BF	.281	.406	.406	.531
KEYWAY	1/8x1/16	3/16x3/32		1/4x1/8
BORE	^{+0.01} _{-0.000}	.5005*	.6255	.8755

*42C adaptor has .3755 bore, 3/32 x 3/64 keyway

The input shaft may be driven in either direction.



2D DRAWINGS & 3D MODELS
www.WINSMITH.com



XDSD Worm/Worm Double Reduction Model

XDSD
Universal
Solid Input Shaft
Hollow Output Shaft
Housing Mount



SHIPPING WEIGHTS (lb.) ♦							
MODEL	E17	E20	E24	E26	E30	E35	E43
DSND	31	36	57	67	80	115	175
MDSND	34	38	60	69	84	117	179
CDSND	37	41	64	72	88	120	185

All motorized weights are for 48C to 140TC adaptor sizes. Add 10% for 180TC/210TC adaptor sizes.

♦Weights are approximate and include shipping carton.

DIMENSIONS

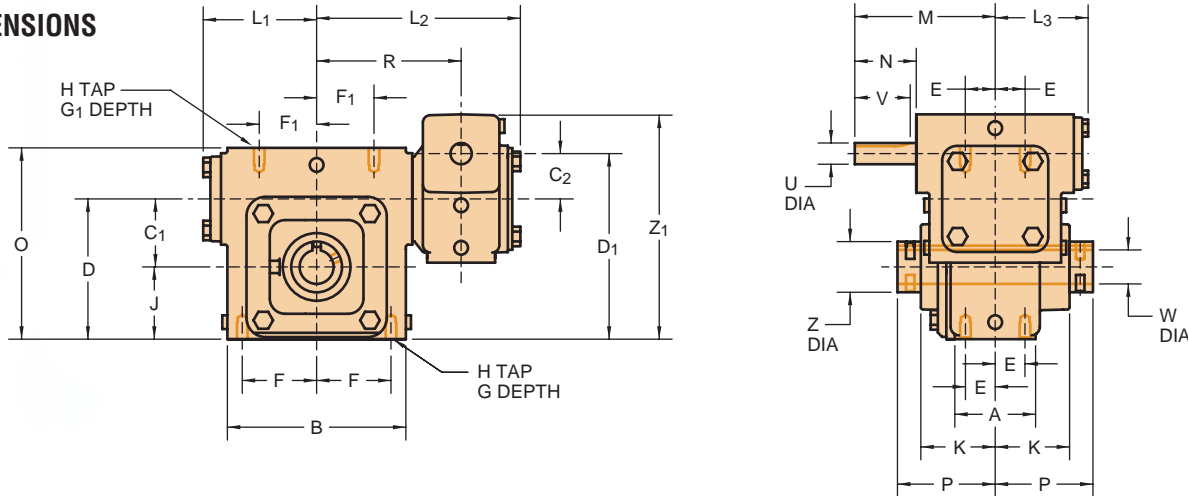

SPEED REDUCER DIMENSIONS (in.)

Size	A	B	C ₁	C ₂	D	D ₁	E	F	F ₁	G DEPTH	G ₁ DEPTH	H TAP	J	K	L ₁	L ₂	L ₃	M	O	P	R	Z	Z ₁	INPUT SHAFT			
																								U*	N	V	KEYWAY
E17	2.38	4.63	1.750	1.333	3.88	5.21	.88	1.94	1.69	.56	.56	3/8-16	2.13	2.44	3.44	6.09	2.83	4.13	5.38	3.13	4.25	1.49	6.36	.625	1.81	1.63	3/16x3/32
E20	2.38	5.25	2.000	1.333	4.13	5.46	.88	2.19	1.69	.56	.56	3/8-16	2.13	2.63	3.44	6.09	2.83	4.13	5.63	3.31	4.25	2.00	6.61	.625	1.81	1.63	3/16x3/32
E24	3.13	5.38	2.375	1.750	5.25	7.00	1.13	2.19	2.19	.63	.57	1/2-13	2.88	2.75	4.50	7.65	3.44	4.75	7.25	3.44	5.75	2.25	8.35	.750	1.94	1.69	3/16x3/32
E26	3.13	5.88	2.625	1.750	5.75	7.50	1.13	2.44	2.44	.63	.69	1/2-13	3.13	2.81	4.50	7.65	3.44	4.75	7.88	3.50	5.75	2.50	8.85	.750	1.94	1.69	3/16x3/32
E30	3.50	6.62	3.000	2.000	6.50	8.50	1.31	2.75	2.75	.75	.75	1/2-13	3.50	3.00	4.63	8.15	3.44	5.00	9.00	3.69	6.25	2.63	9.85	.750	2.19	1.75	3/16x3/32
E35	3.75	7.69	3.500	2.000	7.50	9.50	1.31	3.25	3.25	1.00	1.00	5/8-11	4.00	3.38	5.06	8.40	3.44	5.00	10.13	4.13	6.50	2.87	10.85	.750	2.19	1.75	3/16x3/32
E43	4.38	8.75	4.250	2.625	8.63	11.25	1.63	3.75	3.75	1.00	1.00	5/8-11	4.38	3.63	5.88	10.02	4.50	6.50	11.50	4.38	7.56	3.88	13.40	1.000	2.75	2.63	1/4x1/8

* Shaft diameter tolerances +.000 -.001 Dimensions shown are for construction purposes only. Please contact Winsmith for certified dimension sheets.

HOLLOW OUTPUT SHAFT BORES

(S) Standard Bore (M) Machined to Size Bore (B) Bushing*
 *Bushing for use with standard bore only

W**	KEYWAY	E17	E20	E24	E26	E30	E35	E43
.625	5/8	3/16x3/32	M/B					
.750	3/4	3/16x3/32	M/B	B				
.875	7/8	3/16x3/32	S	B				
1.000	1	1/4x1/8	S	M/B	M/B	B		
1.125	1-1/8	1/4x1/8	B	M/B	B			
1.188	1-3/16	1/4x1/8	M/B	B	B			
1.250	1-1/4	1/4x1/8	M/B	M/B	M/B	M/B	M/B	
1.375	1-3/8	5/16x5/32		B	B	B		
*1.438	1-7/16	3/8x3/16	S	M/B	B	B	M/B	
1.500	1-1/2	3/8x3/16		S	M/B	M/B	M/B	B
1.625	1-5/8	3/8x3/16						S
1.688	1-11/16	3/8x3/16			S	M/B	S	S
1.750	1-3/4	3/8x3/16			B	B	B	B
1.875	1-7/8	1/2x1/4				S	B	B
*1.938	1-15/16	1/2x1/4			S	M/B	M/B	M/B
2.000	2	1/2x1/4				M/B	S	S
*2.188	2-3/16	1/2x1/4				S	M/B	M/B
2.250	2-1/4	1/2x1/4						B
2.438	2-7/16	5/8x5/16						M/B
2.500	2-1/2	5/8x5/16						B
2.750	2-3/4	5/8x5/16						S

** Bore tolerances +.000 +.002 Two puller slots opposed on all hollow output shafts
 * Bore size 1.438 on size E20; keyway is 3/8x1/8. * Bore size 1.938 on size E30; keyway is 1/2x3/16
 * Bore size 2.188 on size E35; keyway is 1/2x1/8. Contact Winsmith for other bore sizes

AVAILABLE SHAFT ARRANGEMENTS AND RELATIVE SHAFT ROTATIONS

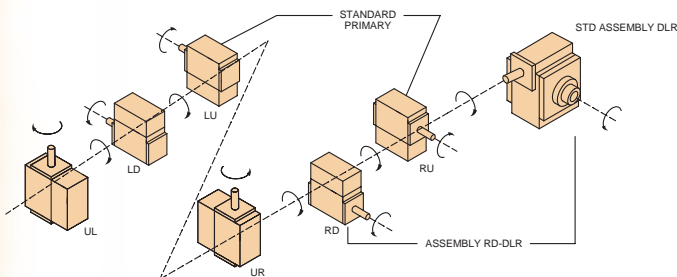

The input shaft may be driven in either direction.



MDSD - CDSD Worm/Worm Double Reduction Models

MDSD
Universal
Quill Input Adaptor
Hollow Output Shaft
Housing Mount



CDSD
Universal
Coupled Input Adaptor
Hollow Output Shaft
Housing Mount



Couplings available, see page 106 for selection chart.

DIMENSIONS

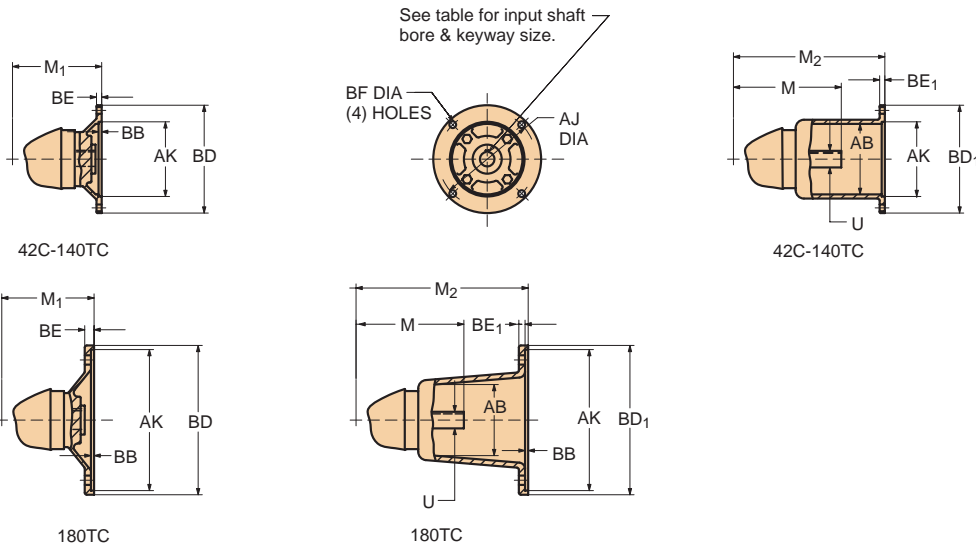

Size	QUILL INPUT ADAPTOR			COUPLED INPUT ADAPTOR											
	M ₁ 42C-48C	M ₁ 56C-140TC	M ₁ 180TC	42C-48C			56C-140TC			180TC			M	U	KEYWAY
				AB	M ₂	BE ₁	AB	M ₂	BE ₁	AB	M ₂	BE ₁			
E17	3.56	3.63*	NA	2.50	6.81	.38	3.00	6.75	.31	NA			4.13	.625	1/8 x 1/16
E20	3.56	3.63*	NA	2.50	6.81	.38	3.00	6.75	.31	NA			4.13	.625	1/8 x 1/16
E24	4.06	4.06	NA	2.50	7.56	.38	3.75	7.50	.38	3.75	8.44	.50	4.75	.750	3/16 x 3/32
E26	4.06	4.06	NA	2.50	7.56	.38	3.75	7.50	.38	3.75	8.44	.50	4.75	.750	3/16 x 3/32
E30	4.06	4.06	NA	2.50	7.56	.38	3.75	7.50	.38	3.75	8.44	.50	5.00	.750	3/16 x 3/32
E35	4.06	4.06	NA	2.50	7.56	.38	3.75	7.50	.38	3.75	8.44	.50	5.00	.750	3/16 x 3/32
E43	NA	5.38	5.38	NA			4.13	9.13	.38	4.25	10.19	.50	6.50	1.000	1/4 x 1/8

*56C adaptor only

AVAILABLE SHAFT ARRANGEMENTS AND RELATIVE SHAFT ROTATIONS

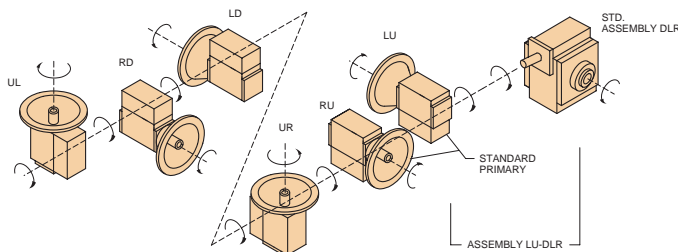

The input shaft may be driven in either direction.

INPUT ADAPT. DIM.	42C 48C	56C	140TC	180TC
AJ	3.75	5.88	5.88	7.25
AK	3.00	4.50	4.50	8.50
BB	.19	.19	.19	.19
BD	4.50	6.50	6.50	9.00
BD ₁	4.50	6.63	6.63	9.00
BE	.34	.31	.31	.38
BF	.281	.406	.406	.531
KEYWAY	1/8 x 1/16	3/16 x 3/32		1/4 x 1/8
BORE	^{+0.01} -0.00	.5005*	.6255	.8755

*42C adaptor has .3755 bore, 3/32 x 3/64 keyway



2D DRAWINGS & 3D MODELS
www.WINSMITH.com



XSTD - MSTD, XSBD - MSBD, XSJD - MSJD, Worm/Worm Double Reduction Models

SHIPPING WEIGHTS (lb.) ♦							
MODEL	E17	E20	E24	E26	E30	E35	E43
XSTD	35	40	62	73	88	125	189
MSTD	38	42	65	75	92	127	193
CSTD	41	45	69	78	96	130	199

All motorized weights are for 48C to 140TC adaptor sizes. Add 10% for 180TC/210TC adaptor sizes.

♦ Weights are approximate and include shipping carton.

SHIPPING WEIGHTS (lb.) ♦							
MODEL	E17	E20	E24	E26	E30	E35	E43
XSBD	35	40	62	73	88	125	189
MSBD	38	42	65	75	92	127	193
CSBD	41	45	69	78	96	130	199

All motorized weights are for 48C to 140TC adaptor sizes. Add 10% for 180TC/210TC adaptor sizes.

♦ Weights are approximate and include shipping carton.

SHIPPING WEIGHTS (lb.) ♦							
MODEL	E17	E20	E24	E26	E30	E35	E43
XSJD	34	41	63	73	88	124	186
MSJD	37	43	66	75	92	126	190
CSJD	40	46	70	78	96	129	196

All motorized weights are for 48C to 140TC adaptor sizes. Add 10% for 180TC/210TC adaptor sizes.

♦ Weights are approximate and include shipping carton.

Available Shaft Arrangements And Relative Shaft Rotations*

XSTD Worm-On-Top Solid Input Shaft Hollow Output Shaft Base Mount

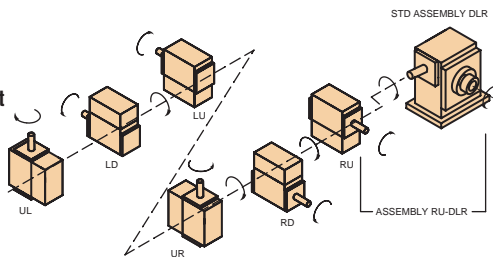

■ See page 54 for secondary stage dimensions

MSTD Worm-On-Top Quill Input Adaptor Hollow Output Shaft Base Mount

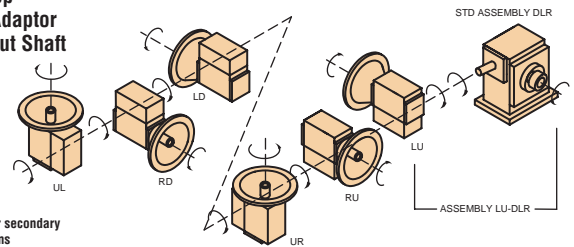

■ See page 54 for secondary stage dimensions

XSBD Worm-On-Bottom Solid Input Shaft Hollow Output Shaft Base Mount

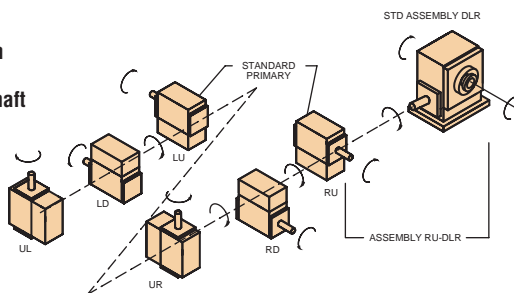

■ See page 56 for secondary stage dimensions

MSBD Worm-On-Bottom Quill Input Adaptor Hollow Output Shaft Base Mount

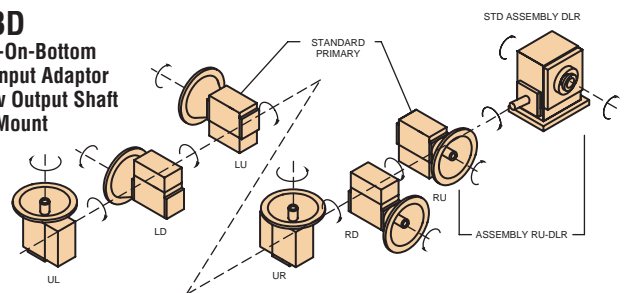

■ See page 56 for secondary stage dimensions

XSJD "J" Vertical Solid Input Shaft Hollow Output Shaft Bracket Mount

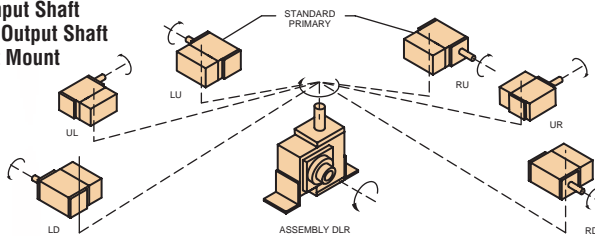

■ See page 58 for secondary stage dimensions

MSJD "J" Vertical Quill Input Adaptor Hollow Output Shaft Bracket Mount

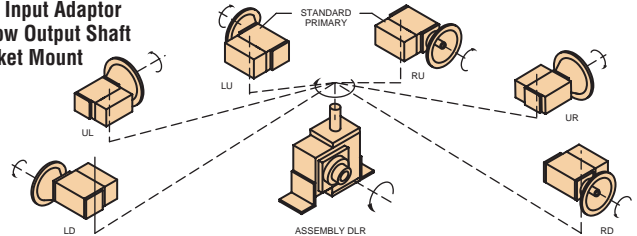

■ See page 58 for secondary stage dimensions

* The input shaft may be driven in either direction.

XSUD - MSUD, XSHD - MSHD, XSRD - MSRD, Worm/Worm Double Reduction Models

SHIPPING WEIGHTS (lb.) ♦							
MODEL	E17	E20	E24	E26	E30	E35	E43
XSUD	35	42	63	74	90	126	188
MSUD	38	44	66	76	94	128	192
CSUD	41	47	70	79	98	131	198

All motorized weights are for 48C to 140TC adaptor sizes. Add 10% for 180TC/210TC adaptor sizes.

♦ Weights are approximate and include shipping carton.

SHIPPING WEIGHTS (lb.) ♦							
MODEL	E17	E20	E24	E26	E30	E35	E43
XSHD	35	41	63	73	86	126	
MSHD	38	43	66	75	90	128	
CSHD	41	46	70	78	94	131	

All motorized weights are for 48C to 140TC adaptor sizes. Add 10% for 180TC/210TC adaptor sizes.

♦ Weights are approximate and include shipping carton.

SHIPPING WEIGHTS (lb.) ♦							
MODEL	E17	E20	E24	E26	E30	E35	E43
XSRD	36	41	58	68	94	129	206
MSRD	39	44	61	71	97	132	209
CSR	42	47	65	75	101	136	214

All motorized weights are for 48C to 140TC adaptor sizes. Add 10% for 180TC/210TC adaptor sizes.

♦ Weights are approximate and include shipping carton.

Available Shaft Arrangements And Relative Shaft Rotations*

XSUD "U" Flange Solid Input Shaft Hollow Output Shaft Bracket Mount

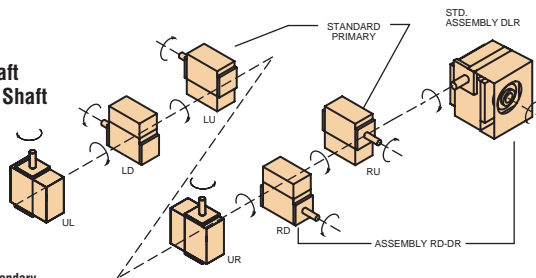

■ See page 60 for secondary stage dimensions

MSUD "U" Flange Quill Input Adaptor Hollow Output Shaft Bracket Mount

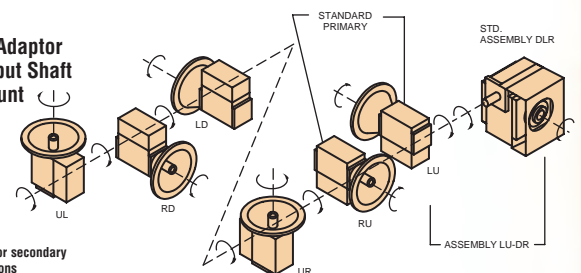

■ See page 60 for secondary stage dimensions

XSHD Hanger Solid Input Shaft Hollow Output Shaft Bracket Mount

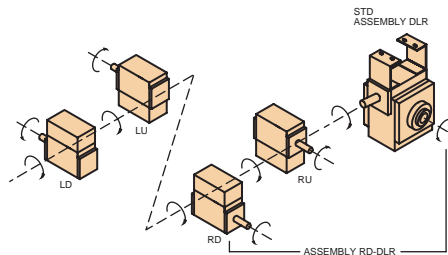

■ See page 62 for secondary stage dimensions

MSHD Hanger Quill Input Adaptor Hollow Output Shaft Bracket Mount

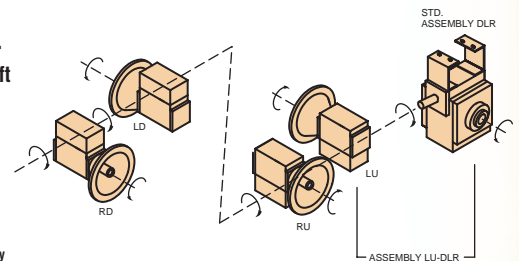

■ See page 62 for secondary stage dimensions

XSRD Torque Arm Solid Input Shaft Hollow Output Shaft Bracket Mount

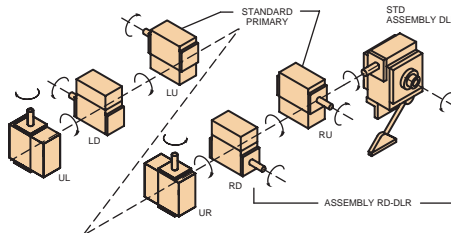

■ See page 64 for secondary stage dimensions

MSRD Torque Arm Quill Input Adaptor Hollow Output Shaft Bracket Mount

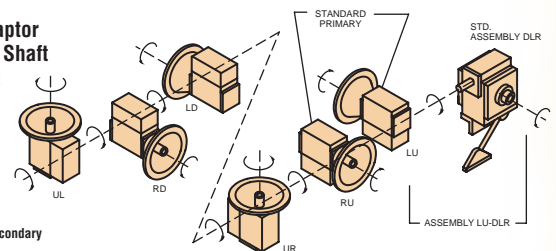

■ See page 64 for secondary stage dimensions

* The input shaft may be driven in either direction.



XSFD Worm/Worm Double Reduction Model

XSFD
Flange
Solid Input Shaft
Hollow Output Shaft
Flange Mount



SHIPPING WEIGHTS (lb.) ♦							
MODEL	E17	E20	E24	E26	E30	E35	E43
XSFD	34	40	64	71	89	115	200
MSFD	37	43	67	74	92	118	204
CSFD	40	46	71	78	96	120	209

All motorized weights are for 48C to 140TC adaptor sizes. Add 10% for 180TC/210TC adaptor sizes.

♦Weights are approximate and include shipping carton.

DIMENSIONS

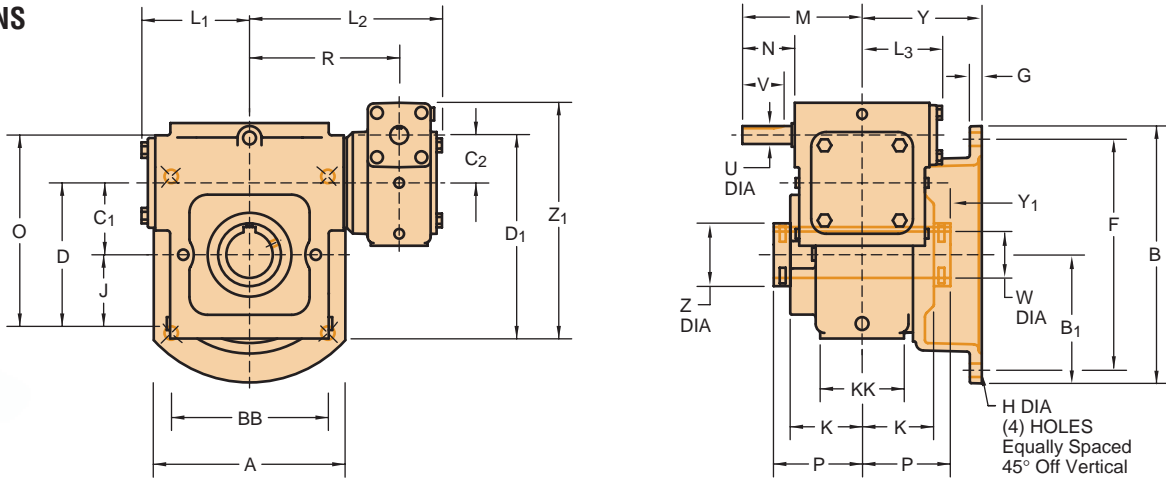

SPEED REDUCER DIMENSIONS (in.)

Size	A	B	B ₁	BB	C ₁	C ₂	D	D ₁	F DIA	G	H	J	K	KK	L ₁	L ₂	L ₃	M	O	P	R	Y	Y ₁	Z	Z ₁	INPUT SHAFT			
																										U*	N	V	KEYWAY
E17	4.88	6.75	3.38	4.63	1.750	1.333	3.88	5.21	5.875	.38	.344	2.13	2.44	2.38	3.44	6.09	2.83	4.13	5.38	3.13	4.25	3.50	.38	1.49	6.36	.625	1.81	1.63	3/16x3/32
E20	6.00	7.63	3.81	5.25	2.000	1.333	4.13	5.46	6.500	.38	.406	2.13	2.63	2.38	3.44	6.09	2.83	4.13	5.63	3.31	4.25	3.38	.06	2.00	6.61	.625	1.81	1.63	3/16x3/32
E24	7.38	8.63	4.31	5.38	2.375	1.750	5.25	7.00	7.500	.38	.406	2.88	2.75	3.13	4.50	7.65	3.44	4.75	7.25	3.44	5.75	3.50	.06	2.25	8.35	.750	1.94	1.69	3/16x3/32
E26	7.75	9.13	4.56	5.88	2.625	1.750	5.75	7.50	8.000	.38	.406	3.13	2.81	3.13	4.50	7.65	3.44	4.75	7.88	3.50	5.75	3.63	.13	2.50	8.85	.750	1.94	1.69	3/16x3/32
E30	8.00	10.75	5.38	6.62	3.000	2.000	6.50	8.50	9.250	.50	.563	3.50	3.00	3.50	4.63	8.15	3.44	5.00	9.00	3.69	6.25	5.00	1.31	2.63	9.85	.750	2.19	1.75	3/16x3/32
E35	9.00	11.00	5.50	7.69	3.500	2.000	7.50	9.50	10.000	.50	.563	4.00	3.38	3.75	5.06	8.40	3.44	5.00	10.13	4.13	6.50	5.00	.88	2.87	10.85	.750	2.19	1.75	3/16x3/32
E43	10.50	13.00	6.50	8.75	4.250	2.625	8.63	11.25	11.500	.63	.688	4.38	3.63	4.38	5.88	10.02	4.50	6.50	11.50	4.38	7.56	5.75	1.38	3.88	13.40	1.000	2.75	2.63	1/4x1/8

* Shaft diameter tolerances +.000 -.001 Dimensions shown are for construction purposes only. Please contact Winsmith for certified dimension sheets.

HOLLOW OUTPUT SHAFT BORES (S) Standard Bore (M) Machined to Size Bore (B) Bushing*

W**	KEYWAY	E17	E20	E24	E26	E30	E35	E43
.625	5/8	3/16x3/32	M/B					
.750	3/4	3/16x3/32	M/B	B				
.875	7/8	3/16x3/32	S	B				
1.000	1	1/4x1/8	S	M/B	M/B	B		
1.125	1-1/8	1/4x1/8	B	M/B	B			
1.188	1-3/16	1/4x1/8	M/B	B	B			
1.250	1-1/4	1/4x1/8	M/B	M/B	M/B	M/B	M/B	
1.375	1-3/8	5/16x5/32		B	B	B		
*1.438	1-7/16	3/8x3/16	S	M/B	B	B	M/B	
1.500	1-1/2	3/8x3/16		S	M/B	M/B	M/B	B
1.625	1-5/8	3/8x3/16			S	M/B	M/B	S
1.688	1-11/16	3/8x3/16			S	M/B	S	S
1.750	1-3/4	3/8x3/16				B	B	B
1.875	1-7/8	1/2x1/4					S	B
*1.938	1-15/16	1/2x1/4				S	M/B	M/B
2.000	2	1/2x1/4					M/B	S
*2.188	2-3/16	1/2x1/4					S	M/B
2.250	2-1/4	1/2x1/4						B
2.438	2-7/16	5/8x5/16						M/B
2.500	2-1/2	5/8x5/16						B
2.750	2-3/4	5/8x5/16						S

** Bore tolerances +.000 +.002 Two puller slots opposed on all hollow output shafts
 * Bore size 1.438 on size E20: keyway is 3/8x1/8. * Bore size 1.938 on size E30: keyway is 1/2x3/16
 * Bore size 2.188 on size E35: keyway is 1/2x1/8. Contact Winsmith for other bore sizes

AVAILABLE SHAFT ARRANGEMENTS AND RELATIVE SHAFT ROTATIONS

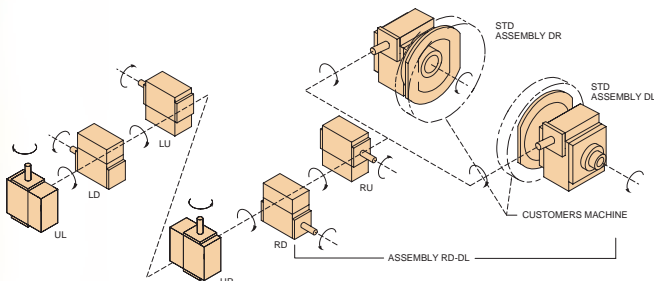

The input shaft may be driven in either direction.



MSFD - CSFD Worm/Worm Double Reduction Models

MSFD
Flange
Quill Input Adaptor
Hollow Output Shaft
Flange Mount



CSFD
Flange
Coupled Input Adaptor
Hollow Output Shaft
Flange Mount



Couplings available, see page 106 for selection chart.

DIMENSIONS

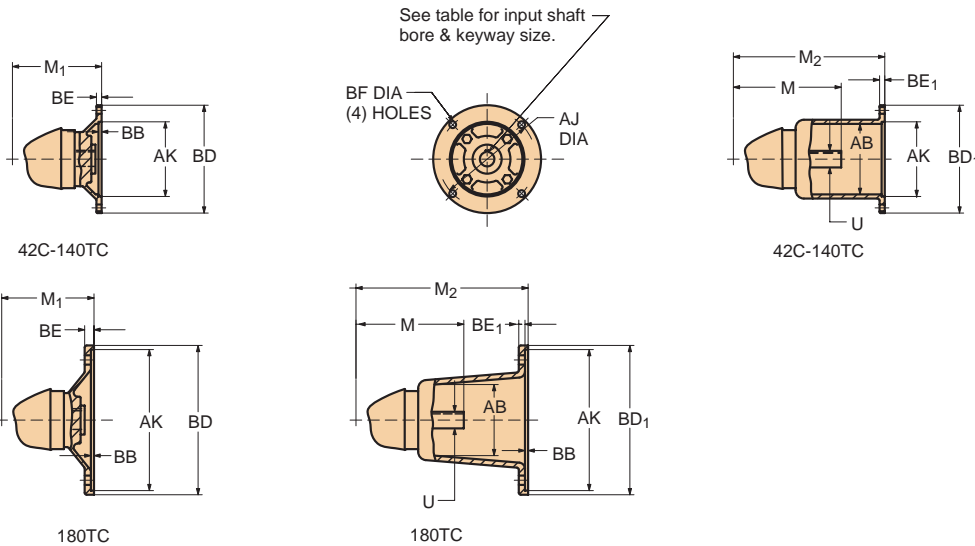

Size	QUILL INPUT ADAPTOR			COUPLED INPUT ADAPTOR									M	U	KEYWAY
	M ₁ 42C-48C	M ₁ 56C-140TC	M ₁ 180TC	42C-48C			56C-140TC			180TC					
				AB	M ₂	BE ₁	AB	M ₂	BE ₁	AB	M ₂	BE ₁			
E17	3.56	3.63*	NA	2.50	6.81	.38	3.00	6.75	.31	NA			4.13	.625	1/8 x 1/16
E20	3.56	3.63*	NA	2.50	6.81	.38	3.00	6.75	.31	NA			4.13	.625	1/8 x 1/16
E24	4.06	4.06	NA	2.50	7.56	.38	3.75	7.50	.38	3.75	8.44	.50	4.75	.750	3/16 x 3/32
E26	4.06	4.06	NA	2.50	7.56	.38	3.75	7.50	.38	3.75	8.44	.50	4.75	.750	3/16 x 3/32
E30	4.06	4.06	NA	2.50	7.56	.38	3.75	7.50	.38	3.75	8.44	.50	5.00	.750	3/16 x 3/32
E35	4.06	4.06	NA	2.50	7.56	.38	3.75	7.50	.38	3.75	8.44	.50	5.00	.750	3/16 x 3/32
E43	NA	5.38	5.38	NA			4.13	9.13	.38	4.25	10.19	.50	6.50	1.000	1/4 x 1/8

*56C adaptor only

AVAILABLE SHAFT ARRANGEMENTS AND RELATIVE SHAFT ROTATIONS

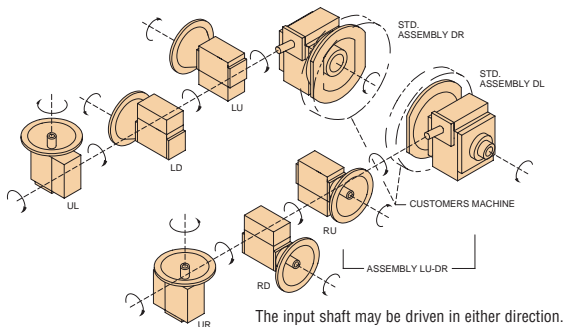

INPUT ADAPT. DIM.	42C 48C	56C	140TC	180TC
AJ	3.75	5.88	5.88	7.25
AK	3.00	4.50	4.50	8.50
BB	.19	.19	.19	.19
BD	4.50	6.50	6.50	9.00
BD ₁	4.50	6.63	6.63	9.00
BE	.34	.31	.31	.38
BF	.281	.406	.406	.531
KEYWAY	1/8 x 1/16	3/16 x 3/32		1/4 x 1/8
BORE	^{+0.01} -0.000	.5005*	.6255	.8755

*42C adaptor has .3755 bore, 3/32 x 3/64 keyway



2D DRAWINGS & 3D MODELS
www.WINSMITH.com



Accessories

HOLLOW OUTPUT SHAFT BUSHINGS

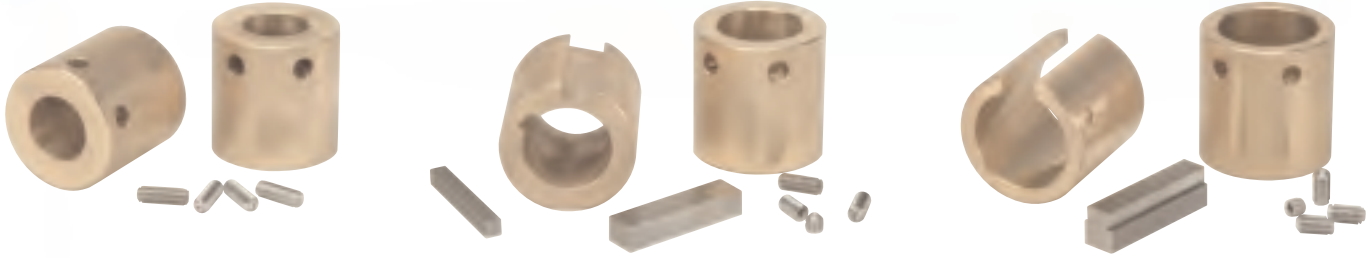

Cast Bore Bushing Kit
TYPE (C)
 (2) Cast Bore Bushings

Keyed Bushing Kit
TYPE (K)
 (1) Keyed Bushing
 (1) Plain Bushing
 (2) Drive Keys

Slotted Bushing Kit
TYPE (S)
 (1) Slotted Bushing
 (1) Plain Bushing
 (1) Drive Key

HOLLOW SHAFT BUSHING CHART

SIZE	BUSHING I.D.	DRIVEN SHAFT O.D.	BUSHING LENGTH	DRIVEN SHAFT KEYWAY	KIT TYPE	KIT#
E17	0.625	5/8	1.50	3/16 X 3/32	S*	WKE850578
	0.750	3/4		3/16 X 3/32	S*	WKE850579
1.000 STANDARD BORE - NO BUSHING REQUIRED**						
E20	0.630*		1.75	*	C	WKE850483
	0.750	3/4		3/16 X 3/32	K	WKE850638
	0.875	7/8		3/16 X 3/32	K	WKE850659
	1.000	1		1/4 X 1/8	K	WKE850468
	1.125	1-1/8		1/4 X 1/8	S*	WKE850660
	1.188	1-3/16		1/4 X 1/8	S*	WKE850625
	1.250	1-1/4		1/4 X 1/8	S*	WKE850469
1.438 STANDARD BORE - NO BUSHING REQUIRED**						
E24	0.750*		1.75	*	C	WKE850484
	1.000	1		1/4 X 1/8	S*	WKE850653
	1.125	1-1/8		1/4 X 1/8	S*	WKE850661
	1.188	1-3/16		1/4 X 1/8	S*	WKE850662
	1.250	1-1/4		1/4 X 1/8	S*	WKE850470
	1.375	1-3/8		5/16 X 5/32	S*	WKE850663
	1.438	1-7/16		3/8 X 3/16	S	WKE850471
1.500 STANDARD BORE - NO BUSHING REQUIRED**						
E26	0.880*		1.75	*	C	WKE850485
	1.000	1		1/4 X 1/8	K	WKE850627
	1.125	1-1/8		1/4 X 1/8	K	WKE877792
	1.188	1-3/16		1/4 X 1/8	S*	WKE850634
	1.438	1-7/16		3/8 X 3/16	S	WKE850472
	1.250	1-1/4		1/4 X 1/8	S*	WKE850479
	1.375	1-3/8		5/16 X 5/32	S*	WKE850664
	1.500	1-1/2		3/8 X 3/16	S	WKE850473
	1.688 STANDARD BORE - NO BUSHING REQUIRED**					

SIZE	BUSHING I.D.	DRIVEN SHAFT O.D.	BUSHING LENGTH	DRIVEN SHAFT KEYWAY	KIT TYPE	KIT#
E30	1.000*		2.00	*	C	WKE850486
	1.250	1-1/4		1/4 X 1/8	K	WKE850481
	1.375	1-3/8		5/16 X 5/32	S*	WKE850665
	1.438	1-7/16		3/8 X 3/16	S	WKE850474
	1.500	1-1/2		3/8 X 3/16	S*	WKE850637
	1.688	1-11/16		3/8 X 3/16	S*	WKE850475
	1.750	1-3/4		3/8 X 3/16	S*	WKE850666
1.938 STANDARD BORE - NO BUSHING REQUIRED**						
E35	1.000*		2.19	*	C	WKE850487
	1.250	1-1/4		1/4 X 1/8	K	WKE850582
	1.438	1-7/16		3/8 X 3/16	S*	WKE850482
	1.500	1-1/2		3/8 X 3/16	S*	WKE850639
	1.750	1-3/4		3/8 X 3/16	S*	WKE850656
	1.938	1-15/16		1/2 X 1/4	S	WKE850476
2.000	2	1/2 X 1/4	S	WKE850477		
2.188 STANDARD BORE - NO BUSHING REQUIRED**						
E43	1.500*		2.75	*	C	WKE850562
	1.500	1-1/2		3/8 X 3/16	K	WKE850654
	1.750	1-3/4		3/8 X 3/16	S*	WKE850667
	1.875	1-7/8		1/2 X 1/4	S*	WKE850668
	1.938	1-15/16		1/2 X 1/4	S	WKE878017
	2.000	2		5/8 X 5/16	K	WKE850593
	2.188	2-3/16		1/2 X 1/4	S*	WKE850560
	2.250	2-1/4		1/2 X 1/4	S*	WKE850669
	2.438	2-7/16		5/8 X 5/16	S	WKE850561
	2.500	2-1/2		5/8 X 5/16	S	WKE878080
2.750 STANDARD BORE - NO BUSHING REQUIRED**						

S* = Bushing uses a step key
 * Rough bore size, bushing to be customer bored and keyed
 ** Bore tolerances +.000 +.002

Accessories

QUILL INPUT BUSHINGS



1 Piece Bushing

2 Piece Bushing

MOTOR FLANGE (SHAFT DIAMETER)	REDUCER INPUT ADAPTOR (BORE SIZE)	BUSHING LENGTH	KEYWAY SIZE	TYPE	KIT #
42C (0.375)	56C (0.625)	1.88	3/32 X 3/64	2 PIECE	WK9838045
48C (0.500)	56C (0.625)	2.00	1/8 X 1/16	2 PIECE	WK9838046
56C (0.625)	140TC (0.875)	1.44	3/16 X 3/32	1 PIECE	WK9810170
140TC (0.875)	180TC (1.125)	2.00	3/16 X 3/32	2 PIECE	WK9810174

HOLLOW SHAFT COVERS

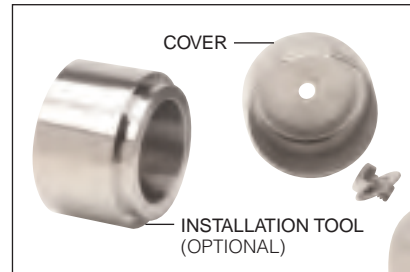
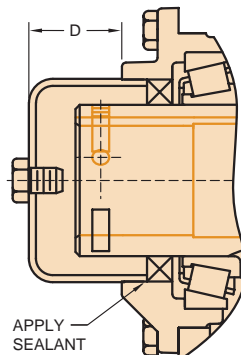
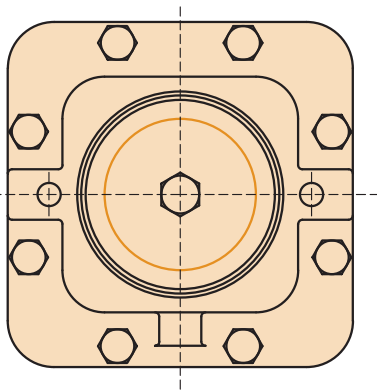

SE Encore shaft covers provide an economical method for protecting the rotating shaft and isolating the seal from outside contaminants. All shaft covers are made from corrosion resistant stainless steel and fit over either shaft end while allowing at least one half inch of clearance for a driven shaft keeper plate.

DIMENSIONS

SIZE	D
E17	1.31
E20	1.25
E24	1.31
E26	1.38
E30	1.56
E35	1.56
E43	1.25

Parts Included in Cover Kit:

- Cover
- Bolt and Washer
- Installation Instructions

KIT PART NUMBERS

SIZE	COVER	INSTALLATION TOOL*
E17	CKIT917	CTKIT917
E20	CKIT920	CTKIT920
E24	CKIT924	CTKIT924
E26	CKIT926	CTKIT926
E30	CKIT930	CTKIT930
E35	CKIT935	CTKIT935
E43	CKIT943	CTKIT943

*Optional – available separately



2D DRAWINGS & 3D MODELS
www.WINSMITH.com



Accessories

FLEXIBLE COUPLINGS

Flexible couplings are available as an option.

SINGLE REDUCTION	MOTOR SHAFT DIA	0.375	0.500	0.625	0.875	1.125	1.375
	FRAME SIZE	42C	48C	56C	140TC	180TC	210TC
E13 INPUT SHAFT .625	COUPLING SIZE WINSMITH P.N.	U-62 100901	L 075 100045	L 075 100049	L 075 100054	N/A	N/A
E17 INPUT SHAFT .750	COUPLING SIZE WINSMITH P.N.	U-75 100902	L 095 100839	L 075 100046	L 095 100087	L 100 100124	N/A
E20 INPUT SHAFT .750	COUPLING SIZE WINSMITH P.N.	U-75 100902	L 075 100052	L 090 100063	L 090 100065	L 099 100104	N/A
E24/E26 INPUT SHAFT 1.000	COUPLING SIZE WINSMITH P.N.	N/A	N/A	L 090 100085	L 095 100090	L 100 100129	N/A
E30/E35 INPUT SHAFT 1.000	COUPLING SIZE WINSMITH P.N.	N/A	N/A	L 095 100085	L 095 100090	L 100 100129	L 100 100137
E43 INPUT SHAFT 1.250	COUPLING SIZE WINSMITH P.N.	N/A	N/A	L 100 100133	L 100 100127	L 100 100135	L 110 100151

DOUBLE REDUCTION/ HELICAL WORM	MOTOR SHAFT DIA.	0.375	0.500	0.625	0.875	1.125	1.375
	FRAME SIZE	42C	48C	56C	140TC	180TC	210TC
E24/E35 INPUT SHAFT .750	COUPLING SIZE WINSMITH P.N.	U-75 100902	L 095 100839	L 075 100046	L 090 100065	**	N/A
E43 INPUT SHAFT 1.000	COUPLING SIZE WINSMITH P.N.	N/A	N/A	L 095 100085	L 095 100090	L 100 100129	N/A

DOUBLE REDUCTION/ DOUBLE WORM	MOTOR SHAFT DIA	0.375	0.500	0.625	0.875	1.125	1.375
	FRAME SIZE	42C	48C	56C	140TC	180TC	210TC
E17/E20 INPUT SHAFT .625	COUPLING SIZE WINSMITH P.N.	U-62 100901	L 075 100045	L 075 100049	L 075 100054	**	N/A
E24/E26 INPUT SHAFT .750	COUPLING SIZE WINSMITH P.N.	U-75 100902	L 095 100839	L 075 100046	L 095 100087	**	N/A
E30/E35 INPUT SHAFT .750	COUPLING SIZE WINSMITH P.N.	U-75 100902	L 075 100052	L 090 100063	L 090 100065	L 099 100104	N/A
E43 INPUT SHAFT 1.000	COUPLING SIZE WINSMITH P.N.	N/A	N/A	L 095 100085	L 095 100090	L 100 100129	N/A

** Contact Winsmith

COUPLING SIZE	MIN. BORE	MAX. BORE	HORSEPOWER (HP)	
			1800 RPM	1200 RPM
L 070	1/4"	3/4"	1.2	0.84
L 075	1/4"	7/8"	2.5	1.68
L 090	1/4"	1"	4	2.76
L 095	7/16"	1-1/8"	5.4	3.6
L 099	7/16"	1-3/16"	9	6
L 100	7/16"	1-3/8"	11.9	8
L 110	5/8"	1-5/8"	22	15
L 150	5/8"	1-7/8"	36	24
L 190	3/4"	2-1/8"	48	32
U-62	5/16"	5/8"	3.6	2.4
U-75	3/8"	3/4"	5.04	3.36

COUPLED INPUT ADAPTORS – NEMA FRAMES

Coupled input adaptors are available for appropriate motor flange sizes in each center distance. Kits are also available for replacement or field retrofit of non-motorized units.



SIZE			KIT NUMBER		
SINGLE REDUCTION	DOUBLE REDUCTION WORM/WORM	DOUBLE REDUCTION HELICAL/WORM	42C-48C	56C-140TC	180TC
E13 E17-E20 E24-E26	E17-E20 E24-E35* E43	- E24-E35* E43	CK9808429 CK9808430 N/A	CK9808128 CK9808410 CK9808131	N/A CK9808411 CK9808132
			56C-140TC	180TC	210TC
E30	-	-	CK9808417	CK9808418	CK9808418
E35	-	-	CK9808427	CK9808428	CK9808428
E43	-	-	CK9808650	CK9808651	CK9808652

Input Cap And Output Cover Bolt Patterns

Often, the input cap and output cover fasteners are used for securing attachments such as auxiliary plates, flanges, or other equipment to a speed reducer. It is imperative that normal and acceptable engineering practices are maintained such that axial thrust loads and overhung load ratings for SE Encore

products are not exceeded when attaching any type of special flange, adaptor, or auxiliary items. If special mounting configurations are required, contact your local authorized WINSMITH distributor, representative or the factory for assistance.

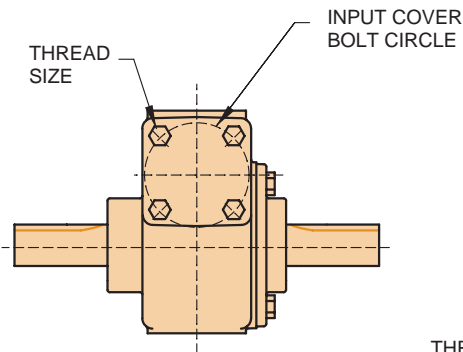

E13 - E43

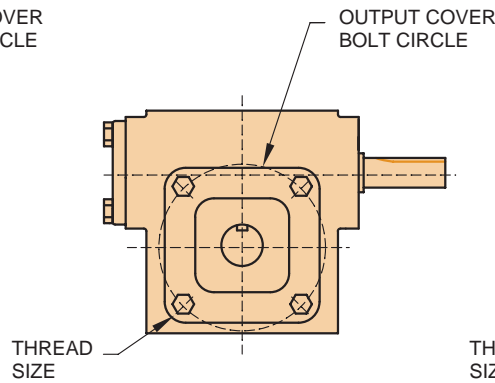

E13 - E20

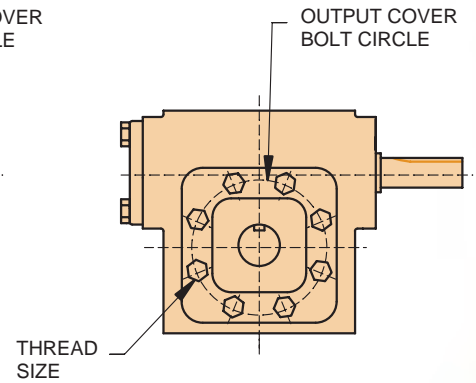

E24 - E43

SIZE	INPUT COVER			OUTPUT COVER			
	BOLT CIRCLE	THREAD SIZE	NO. OF HOLES	BOLT CIRCLE	THREAD SIZE	NO. OF HOLES	SPACING
E13	2.125	1/4-20	4	3.125	5/16-18	4	90°
E17	2.625	5/16-18	4	4.063	5/16-18	4	90°
E20	2.625	5/16-18	4	4.438	5/16-18	4	90°
E24	3.438	3/8-16	4	4.875	5/16-18	8	45°
E26	3.438	3/8-16	4	5.438	5/16-18	8	45°
E30	3.875	3/8-16	4	6.125	3/8-16	8	45°
E35	3.875	3/8-16	4	7.250	3/8-16	8	45°
E43	3.875	3/8-16	4	8.250	3/8-16	8	45°



Lubricant Levels for Special Mounting Positions – Single Reduction Models

SE Encore Integral worm gear speed reducers are factory filled with lubricant for use in the mounting positions shown in the "Standard Mounting" column in the table below. If other mounting positions are required, the oil level in the reducer may need adjustment to ensure that all moving components receive

proper lubrication. Additional mounting positions can be accommodated by referencing the table below or by contacting your local representative or Winsmith. **Note: All SE Encore worm gear speed reducers use Mobil Glygoyle 460 lubricant. Do not mix with other types of lubricant.**

MOUNTING POSITIONS AND LUBRICANT LEVELS FOR SINGLE REDUCTION MODELS

PRODUCT FAMILY	STANDARD MOUNTING	ADDITIONAL MOUNTING POSITIONS					
		INVERTED	INPUT SHAFT HORIZONTAL		INPUT SHAFT VERTICAL		
XDNS XDTS XDUS XDHS							
XDBS							
XDJS							
XDVS							
XDLS							
XDSS XSTS XSUS XSHS							
XSBS							
XSJS							
XSFS							

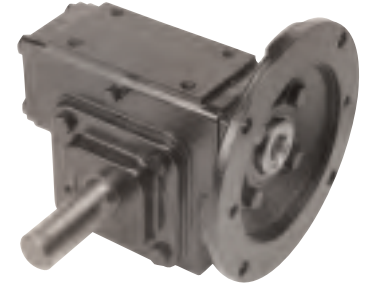

Notes:

1. Fill, vent, level and drain locations are the same for quill and coupled models.
2. Double reduction size E35 and E43 models are supplied with grease fittings on the input shaft to ensure bearing lubrication for all mounting positions.
3. Contact Winsmith when input speeds are less than 1160 rpm to ensure proper lubrication.

- (F) REFILL PLUG
- (V) VENT PLUG
- (L) LEVEL PLUG
- (D) DRAIN PLUG

Lubricant Levels for Special Mounting Positions – Double Reduction Models

SE Encore Integral double reduction speed reducers are factory filled with lubricant for use in the standard mounting positions shown in the table below. If other mounting positions are required, the oil level in the reducer may need adjustment to ensure that all moving components receive proper lubrication.

Additional mounting positions can be accommodated by contacting your local representative or Winsmith. **Note: All SE Encore worm gear speed reducers use Mobil Glygoyle 460 lubricant. Do not mix with other types of lubricant.**

MOUNTING POSITIONS AND LUBRICANT LEVELS FOR DOUBLE REDUCTION MODELS

DOUBLE REDUCTION WORM/WORM STANDARD MOUNTING		DOUBLE REDUCTION HELICAL/WORM STANDARD MOUNTING	
XDND XDTD XDUD XDHD		XDNX XDTX XDUX XDHX	
XDBD		XDBX	
XDJD		XDJX	
XDVD		XDVX	
XDL D		XDLX	
XDSD XSTD XSUD XSHD		XDSX XSTX XSUX XSHX	
XSBD		XSBX	
XSJD		XSJX	
XSFD		XSFX	



Notes:

1. Fill, vent, level and drain locations are the same for quill and coupled models.
2. Double reduction size E35 and E43 models are supplied with grease fittings on the input shaft to ensure bearing lubrication for all mounting positions.
3. Contact Winsmith when input speeds are less than 1160 rpm to ensure proper lubrication.

- (F) REFILL PLUG
- (V) VENT PLUG
- (L) LEVEL PLUG
- (D) DRAIN PLUG



SE Encore Modified Worm Gear Speed Reducers

AVAILABLE IN 1 – 8 WEEKS*

- WinGuard™ Black or White Epoxy Coating System Exceeds ASTM B-117 1000 hour Salt Spray Testing
- Quill, Coupled, or Hydraulic Input Adaptors
- Solid Input Shafts
- Solid and Hollow Output Shafts (Bored to Size or with Bushings)
- Base and Bracket Kits Increase Mounting Options
- Double Reduction Integrated Worm or Helical Primary
- Special Shaft Sizes and Lengths
- Special Ratios
- Special Mountings and Brackets
- Special Housings
- Special Gearing and Materials
- Special Seals and Bearings

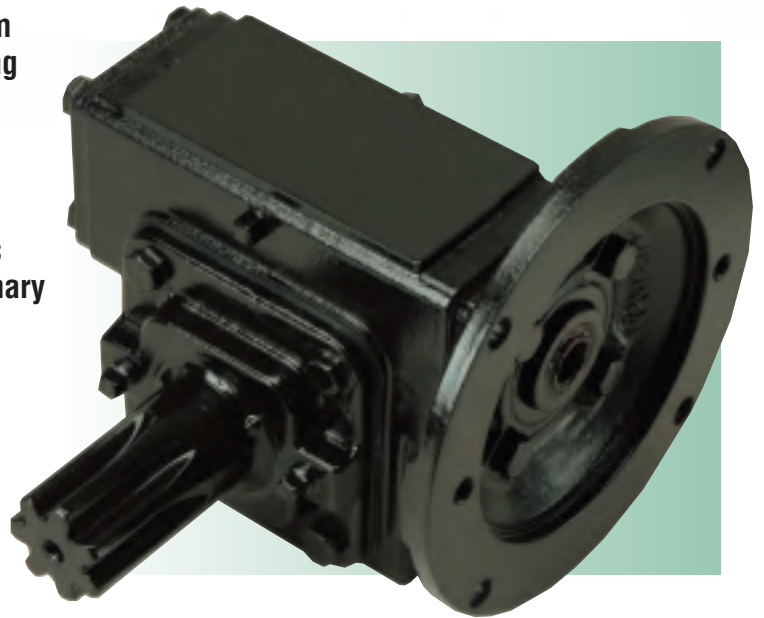

SE Encore Modified Worm Gear Speed Reducers Table of Contents

Modified Worm Gear Examples	111
Double Extended Input Shafts	114
Servo Motor Adaptors	115
Servo Motor Adaptor Capability – Square Face.	116
Servo Motor Adaptor Capability – Round Face	117
Metric Speed Reducers	119
Modified Output Shaft Options.	122
Solid Output Shaft Extensions and Modifications	122
Hollow Output Shaft Modifications.	124
Shaft Locking Devices	126
Shrink Discs	127
Tapered and Taper-Lock® Bushings	128
Seal Modifications and Combinations	129
Long Term Storage	130
Solid Lubricant Bearings	130
Modified Accessories.	131
Special Bases and Brackets	131
Column and Button View Gages	131
Special Ratios, Geometry, and Left Hand Gearing	132
4:1 Ratio Speed Reducer Ratings	134
Worm Gear Ratio Multiplier	137
Drywell	143
Drywell Speed Reducer Ratings.	146
SE Maximizer Series	152
SE Maximizer Plus	152
SE Maximizer Stainless Steel	152
Motion Control “S-Eliminator”	153
Hydraulic Motor Input Adaptor Rings	154

SE ENCORE – MODIFIED

SE Encore Modified worm gear speed reducers are created to exacting and unique customer application specifications that encompass a variety of special reduction combinations, options, input adaptor configurations, and other modifications.** Some examples of SE Encore Modified product configurations include: hydraulic motor adaptors, special gear reductions and gearing geometries, special keys, shaft sizes, housings, metric shafts and flanges, drywell configurations, and many more. Please contact Winsmith for special modifications not listed in this catalog section.

The lubricant in an SE Encore Modified product is filled to a level determined by the reducer’s intended mounting position for optimal performance. Additionally, SE Encore Modified worm gear speed reducers can operate sealed, but are supplied with an open-close vent kit.***

* Typical availability.
 ** Winsmith will mount customer supplied motors.
 *** See “Appendix” section of this catalog for more details.

Modified



SE Encore Modified Worm Gear Speed Reducers

MODIFIED CONFIGURATION PROCEDURE

SIZE

Identify the three digit nomenclature for size appearing in the selection pages of this catalog section.

Example: 1HP input, 30:1 gear reduction, 1750 RPM 1.25 service factor yields a 2.375" center distance speed reducer. The nomenclature for the size of this unit is "E24."

MODEL

There are a wide variety of models available in the Modified product offering. Each is identified at the top of the corresponding dimension page in this section by a complete description and by the four letter (e.g. MDNS) model nomenclature.

MODEL	DESCRIPTION
GSYD	Drywell coupled input adaptor; hollow output shaft, double reduction
CSFD	Coupled input adaptor; flange mount, hollow output shaft, double reduction

RATIO

Identify the required ratio in full format (i.e. 30:1), or in brief format (i.e. 30). A list of available standard and special ratios appears on page 133.

ASSEMBLY

The assembly of a Modified product is described by the relative positions of the input and output shaft. Refer to the dimension pages in this catalog section for the assembly possibilities associated with each speed reducer model.

Example: The nomenclature for a size E20 reducer of model XDNS and assembled with two standard output shaft extensions is stated as "E20 XDNS LR."

Example: The nomenclature of a size E43 reducer of model CDSS with output flange to the right of the input is stated as "E43 CDSS DLR."

INPUT ADAPTOR

Identify the input adaptor for the motor flange being mounted to the Modified product. The dimension pages in this section contain the possible input adaptor selections for each speed reducer size. If an input bushing is desired, specify the desired adaptor size assembled with bushing. These bushings will be factory installed prior to shipment.

Example: The nomenclature for a NEMA 56C adaptor flange is "56C."

HOLLOW OUTPUT SHAFT BORE SIZE

Identify the hollow output shaft bore size of an MDSS using the tables on page xx. Express the bore size as a decimal (Example = 1.438"). Specify a standard bore unit, the desired hollow output bore size, and the output shaft bushing kit part number if an output bore bushing kit is required.

Example: To include an output bushing kit on an E20 CDSS that creates a 0.750" output bore, chose kit number WKE850638 or specify, "Bush output to 0.750" bore."

ACCESSORIES

Identify the required Modified product accessory either by "kit" part number or by description. All accessories in this section of the catalog, except output bushing kits, are factory mounted prior to shipment.

Example: To include an output bushing kit on an E20 CDNS that creates a 0.750" output bore, chose kit number WKE850638 or specify, "Bush output to 0.750" bore."

SPECIAL MOUNTINGS AND LUBRICANT LEVEL

Identify the proper lubricant level for the desired mounting position from the table on pages 108-109. The choices are *Standard, Inverted, Input shaft horizontal, or Input shaft vertical.*

MODIFIED PRODUCT NOMENCLATURE EXAMPLES

SIZE	MODEL	RATIO	ASSEMBLY	INPUT ADAPTOR	HOLLOW OUTPUT SHAFT BORE SIZE	ACCESSORY And MOUNTING	COMPLETE NOMENCLATURE
E17	CSFS	50	L	56C	1.000"	Coupling L 075 100046	E17 CSFS 50 L 56C with Coupling L 075
E24	MDS D	60	DLR	56C	1.000"	WKE850653	E24 MDS D 60 DLR 56C 1.000" Output Bushing for 1.500" Output Bore
E26	XDVD	500	LU-RD	140TC			E26 XDVD 500 LURD 140TC
E30	MDSS	5	DLR	180TC	1.938"	Inverted Mount	E30 MDSS 5 DLR 180TC 1.938 Inverted Mount
E26	CDSS	12.5	DLR	56C	1.438"	YKIT9810176	E26 CDSS 12.5:1 56C 1.438" with Hydraulic Motor Adaptor Ring for SAE-B



2D DRAWINGS & 3D MODELS
www.WINSMITH.com



Modified Worm Gear Speed Reducers

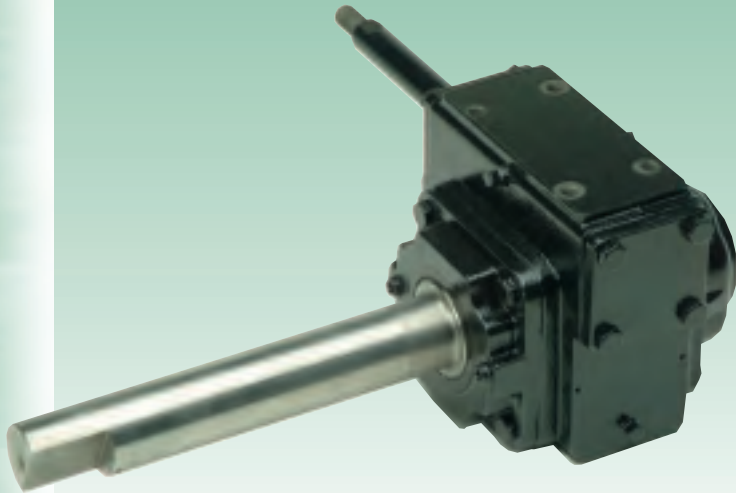

E20 XDNS R Assembly

- Input Shaft Designed for Hand Crank
- Extended and Oversized Output Shaft
- Adjustable Internal Slip Clutch
- Single Reduction



E17 MDNS 2R Assembly 56C

- Double Extended with Quill Input Adaptor
- Brake Mounting Flange
- Solid Output Shaft
- Single Reduction

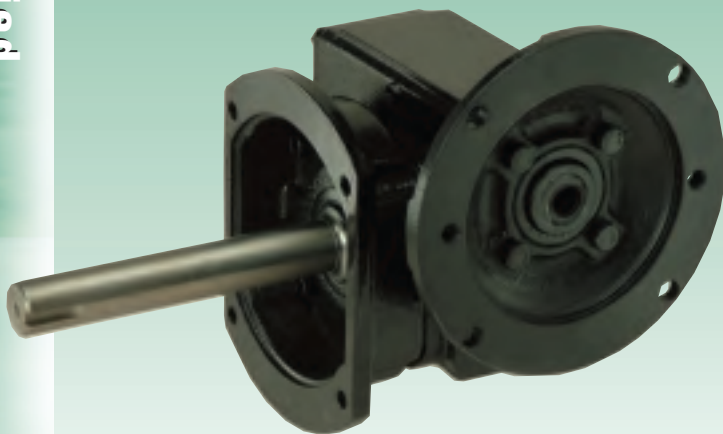

E17 MSFS L Assembly 56C

- Quill Input Adaptor
- Flange Mount
- Extended Solid Output Shaft
- Single Reduction

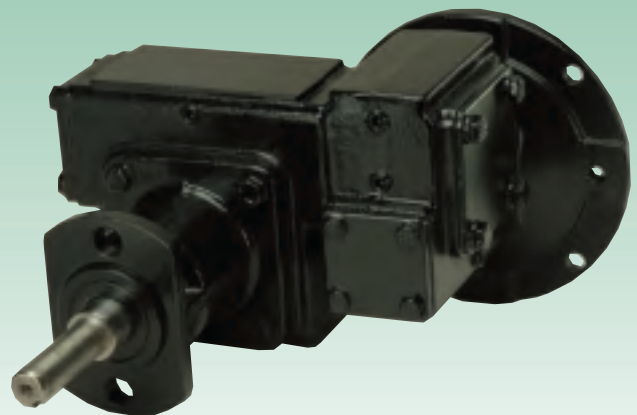

E17 MDND RD-L Assembly 56C

- Quill Input Adaptor
- Special Output Flange
- Worm/Worm Double Reduction

Modified

Modified Worm Gear Speed Reducers



E24 MDSS DR Assembly 56C

- Quill Input Adaptor
- Hollow Output Shaft with a Single QD® Bushing (Split Tapered Bushing)
- Single Reduction

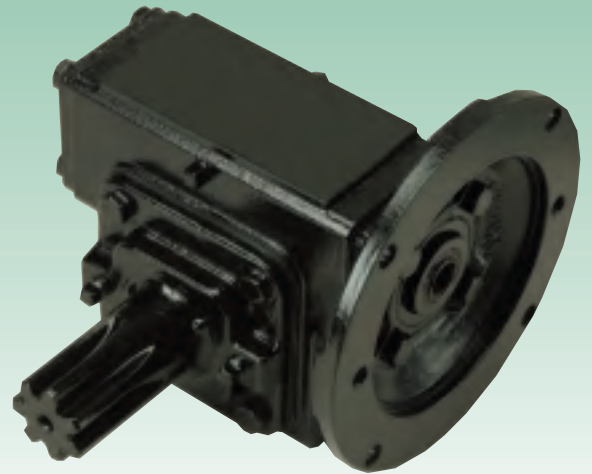

E17 MDNS L Assembly 56C

- Quill Input Adaptor
- Solid Output Shaft with Integral Pinion or External Spline
- Single Reduction

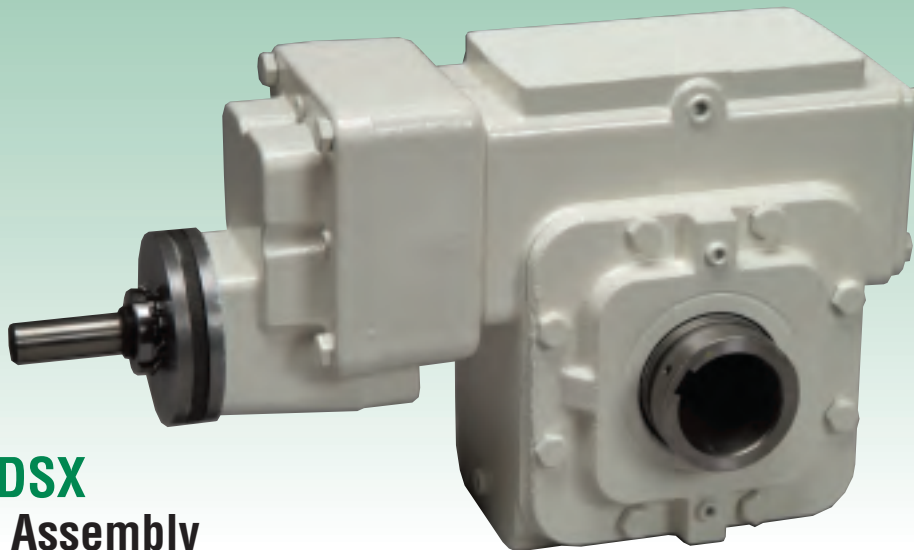

E30 XDSX D-DLR Assembly

- Variable Resistance Solid Input Shaft
- Hollow Output Shaft
- Helical/Worm Double Reduction
- White Epoxy Coating

QD® is a registered trademark of Emerson Power Transmission Manufacturing, L.P.



2D DRAWINGS & 3D MODELS
www.WINSMITH.com



Double Extended Input Shafts

Double extended input shafts with keys accommodate manually driven application requirements. The extended shaft is offered with a hex (strong connection method), but alternative configurations such as special lengths,

drilled & tapped shaft ends, step down shafts, or threaded shafts are available. Please contact Winsmith for specific specifications of hex or other special shaft extensions.

DOUBLE EXTENDED INPUT

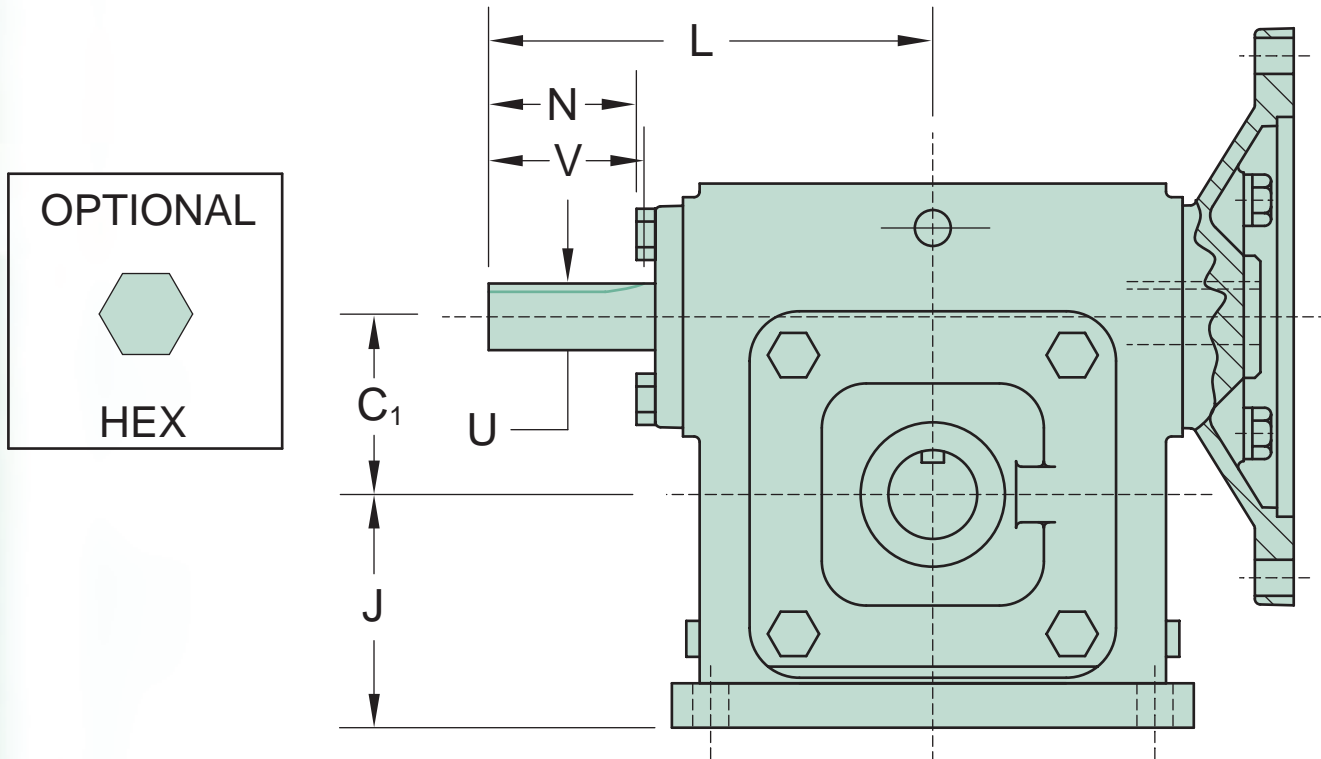

Size	C ₁	D	J	L	INPUT SHAFT DIMENSIONS			
					U*	N	V	KEYWAY
E13	1.333	3.33	2.00	4.13	.625	2.00	1.63	3/16 x 3/32
E17	1.750	4.19	2.44	4.75	.750	1.94	1.69	3/16 x 3/32
E20	2.000	4.63	2.63	5.00	.750	2.19	1.75	3/16 x 3/32
E24	2.375	5.63	3.25	6.50	1.000	2.75	2.38	1/4 x 1/8
E26	2.625	6.13	3.50	6.50	1.000	2.75	2.38	1/4 x 1/8
E30	3.000	7.00	4.00	7.00	.875	3.06	2.38	3/16 x 3/32
E35	3.500	8.00	4.50	7.38	1.000	2.31	2.50	1/4 x 1/8
E43	4.250	9.25	5.00	8.19	1.250	2.31	2.50	1/4 x 1/8

* Shaft diameter tolerances +.000 -.001
Dimensions shown are for construction purposes only. Please contact Winsmith for certified dimension sheets.

Servo Motor Adaptors

The SE Encore series of worm gear speed reducers offers round and square flanged servo adaptors. The oversized adaptor flange design can be modified for most servo motors available in the market. The outline drawings in this section show minimum and maximum base adaptor dimensions. The flange perimeter (BD) and register (AK) are machined to the specific motor interface dimensions. The actual motor mounting dimensions are required when specifying this servo adaptor flange. The servo adaptor design generally uses a coupling connection between the servo motor shaft and the input shaft of the reducer. If the servo motor flange dimensions exceed those shown, contact Winsmith for the required adaptor spacer.



Commonly Available Servo Motor Suppliers

ABB	Cincinnati Milacron	Fenner	Infranor	Ragonot
AEG	CMC	Festo	Isoflux	Reliance Electric
Allen Bradley	Control Techniques	Fimet	Japan Servo	Seiberco
Alltel	Cool Muscle	Fuji	Kollmorgen Inland	SEM
Alsthom	Daewoo	Fukuta	Magnetek Mavilor	Servo Products
Anilam	Danaher	GE Fanuc	Minertia	Servotek
Axor	Drive Tech	GEC	Mitsubishi	Siemens
B&R	Dynetic	Getty	Modicon	Sigma
Baldor	EG&G	Giddings & Lewis	Moog	Stober
Baumuller	ElectroCraft Emerson	Glentech	MFM	Superior Electric
Bautz	Emoteq	Goldline	Omron	Toshiba
Beckhoff	Eurotherm	Gould	Pacific Scientific	Whedco
Berger Lahr	EW HOF	Groschopp	Parvex	Vexta
Bosch	Exlar	Hitachi	Peerless-Winsmith	Vickers
Bridgeport	Fabbrica	Indramat Bosch	PMI	Yaskawa
Brusatori	Fanuc	Industrial Drives	Porter Peerless	
C-Jac	Faulhaber	Industrial Motors	QMC	



Servo Motor Adaptor Capability - Square Face

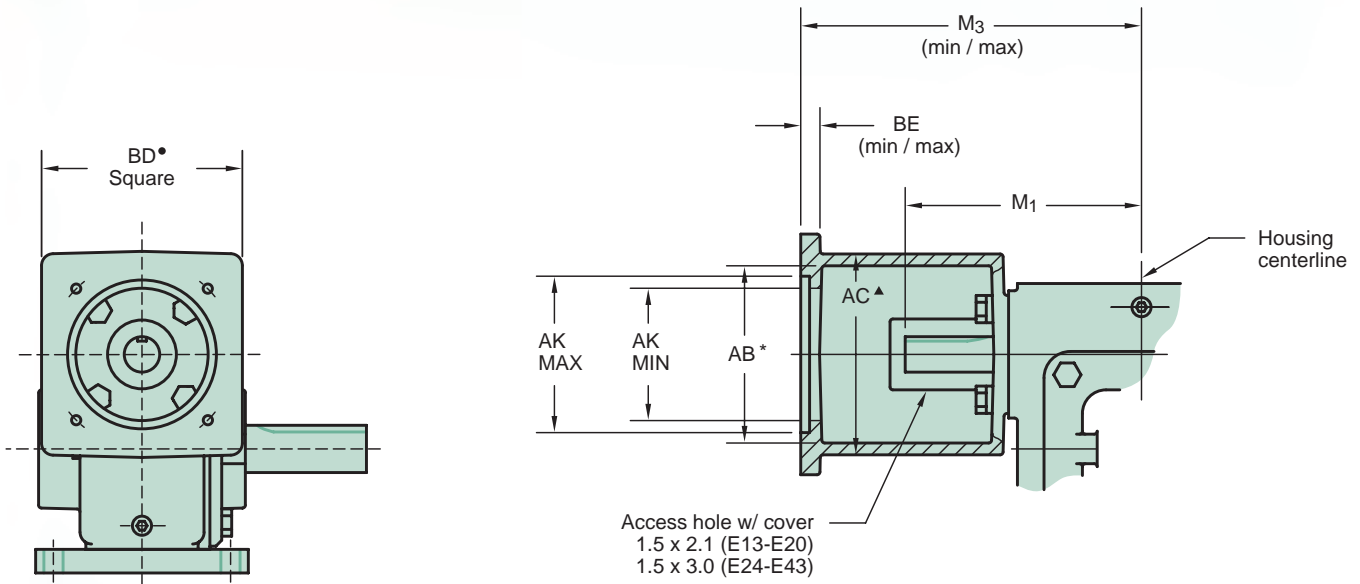

SERVO MOTOR ADAPTOR DIMENSION CAPABILITIES, SQUARE FACE (dimensions in parenthesis are mm)

SIZE	AB* (ID)	AC^	AK		BD*	BE		M ₁	M ₃	
			MIN.	MAX.		MIN.	MAX.		MIN.	MAX.
E13	2.50	3.63	2.00 (51)	4.50 (115)	4.75 (120)	.38	.75	4.12	6.31	6.69
E17	3.00	4.26	2.38 (60)	5.31 (135)	5.56 (140)	.38	.75	4.75	7.19	7.56
E20	3.00	4.26	2.38 (60)	5.31 (135)	5.56 (140)	.38	.75	5.00	7.19	7.56
E24	4.00	5.26	2.75 (70)	6.25 (160)	6.50 (165)	.38	.63	6.50	9.00	9.25
E26	4.00	5.26	2.75 (70)	6.25 (160)	6.50 (165)	.38	.63	6.50	9.00	9.25
E30	3.88	5.38	3.75 (95)	7.25 (184)	7.50 (190)	.38	.75	7.00	9.88	10.25
E35	3.88	5.38	3.75 (95)	7.25 (184)	7.50 (190)	.38	.75	7.38	10.81	11.19
E43	3.88	5.38	3.75 (95)	7.25 (184)	7.50 (190)	.38	.75	8.19	11.62	12.00

* Clearance diameter for coupling inside the adaptor. Coupling OD must also clear the register diameter (AK).

▲ For thru holes in adaptor, motor fastener head must clear this diameter.

• Square flange can be reduced to match motor. To convert from bolt circle diameter to horizontal or vertical distance between mounting holes, divide by 1.41.

Servo Motor Adaptor Capability - Round Face

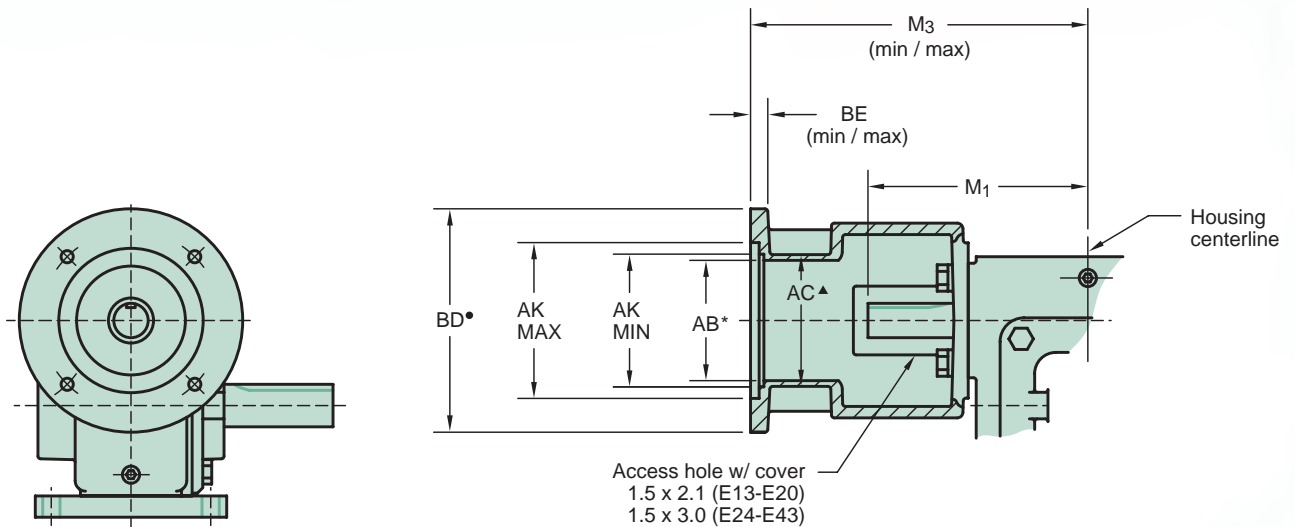

SERVO MOTOR ADAPTOR DIMENSION CAPABILITIES, ROUND FACE (dimensions in parenthesis are mm)

SIZE	ADAPTOR	AB* (ID)	AC [▲]	AK		BD*	BE		M ₁	M ₃	
				MIN.	MAX.		MIN.	MAX.		MIN.	MAX.
E13	One adaptor available for each of these sizes	2.47	2.84	2.38 (60)	6.00 (150)	6.50 (165)	.38	.41	4.12	6.81	6.84
E17		2.47	2.84	2.38 (60)	6.00 (150)	6.50 (165)	.38	.41	4.75	7.56	7.59
E20		2.47	2.84	2.38 (60)	6.00 (150)	6.50 (165)	.38	.41	5.00	7.56	7.59
E24		3.63	4.13	3.88 (100)	7.00 (175)	7.50 (190)	.38	.47	6.50	9.68	9.77
E26		3.63	4.13	3.88 (100)	7.00 (175)	7.50 (190)	.38	.47	6.50	9.68	9.77
E30	Small	3.15	3.65	3.88 (100)	6.00 (150)	6.50 (165)	.38	.54	7.00	10.38	10.54
	Large	4.25	4.88	4.50 (115)	9.38 (238)	9.88 (251)	.38	.66		10.81	10.88
E35	Small	3.15	3.65	3.88 (100)	6.00 (150)	6.50 (165)	.38	.54	7.38	11.31	11.34
	Large	4.25	4.88	4.50 (115)	9.38 (238)	9.88 (251)	.38	.66		11.75	11.81
E43	Small	3.15	3.65	3.88 (100)	6.00 (150)	6.50 (165)	.38	.54	8.19	12.12	12.15
	Large	4.25	4.88	4.50 (115)	9.38 (238)	9.88 (251)	.38	.66		12.56	12.62

* Clearance diameter for coupling inside the adaptor. Coupling OD must also clear the register diameter (AK).

▲ For thru holes in adaptor, motor fastener head must clear this diameter.

● Square flange can be reduced to match motor. To convert from bolt circle diameter to horizontal or vertical distance between mounting holes, divide by 1.41.



WINSMITH

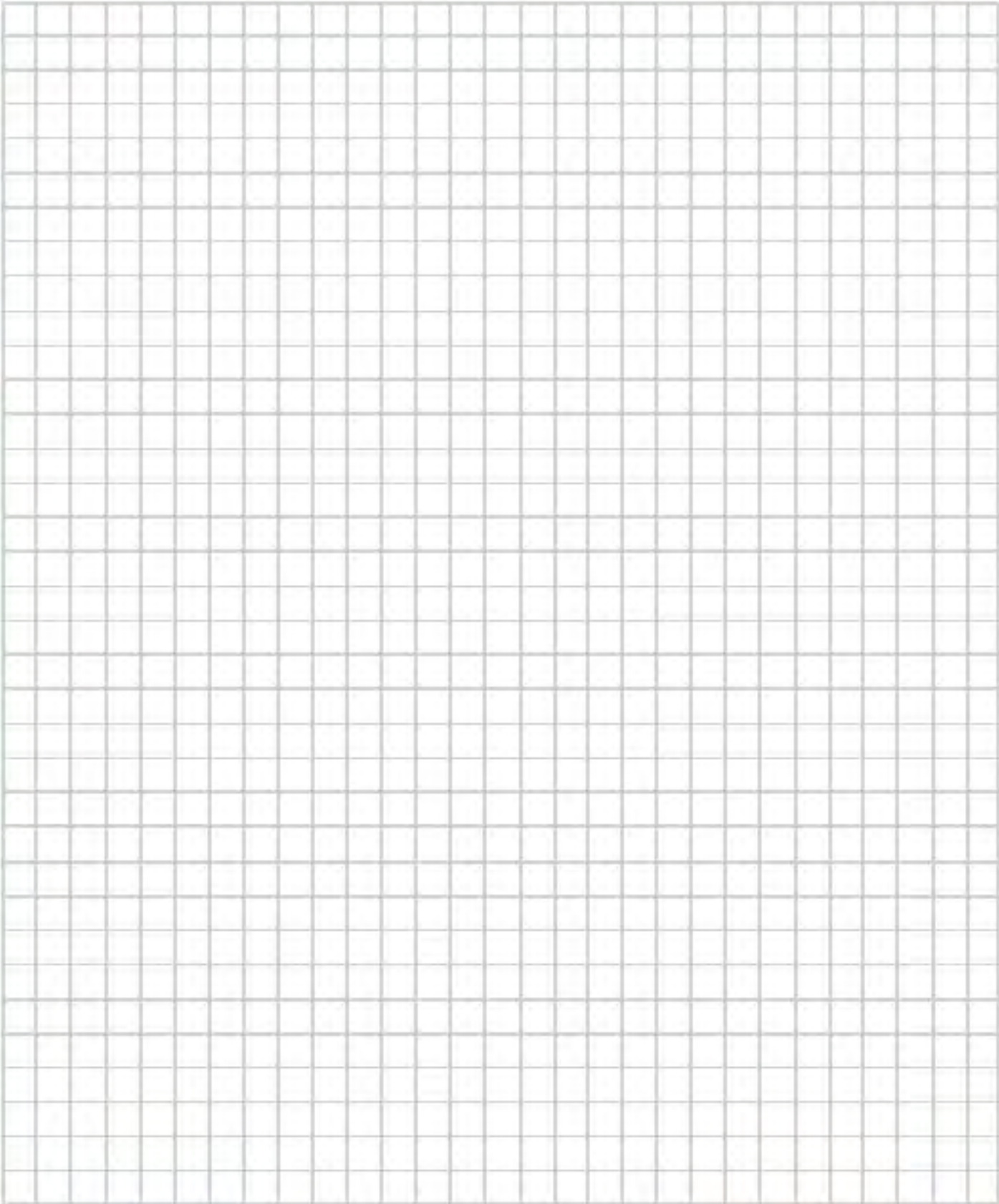

Modified



2D DRAWINGS & 3D MODELS
www.WINSMITH.com



Metric Speed Reducers

SE Encore worm gear speed reducers are available with a metric input adaptor that mates to most IEC B5 and B14 flanges. Additionally, these reducers can be equipped with either a metric solid or hollow output shaft (supplied with a keyed metric bore, including the drive key and locking set screws). All models can be modified with additional options and accessories as depicted in this catalog. IEC motor flange interface dimensions are available on pages 120-121 of this catalog.

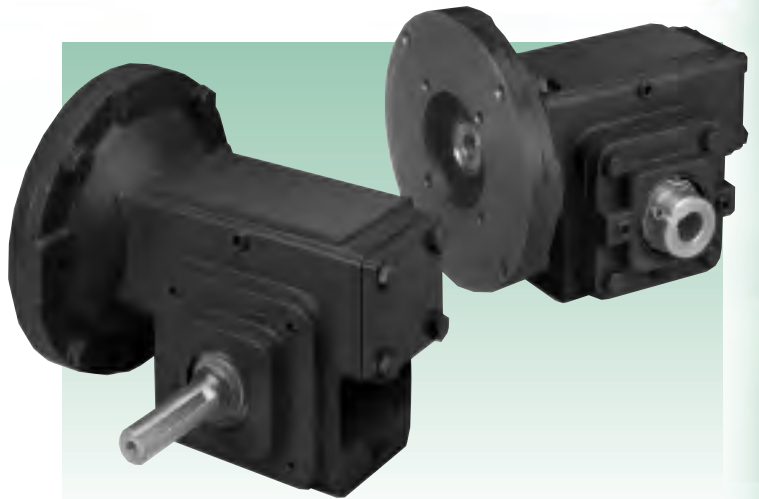

SE Encore worm gear speed reducers are available with IEC compatible B5 or B14 input adaptors and metric shafts.

COMMON METRIC CONVERSIONS

1 watt = 0.0013 HP	
KILOWATTS TO HORSEPOWER	
KW	HP
0.12	0.16
0.18	0.24
0.25	0.34
0.37	0.50
0.55	0.74
0.75	1.01
1.10	1.48
1.50	2.01
2.20	2.95
3.00	4.02
4.00	5.36
5.50	7.38
7.50	10.10
9.20	12.30
11.00	14.80
15.00	20.10
18.50	24.80
22.00	29.50

1 Newton meter = 8.851 lbf-in	
NEWTON METERS TO POUND INCHES	
Nm	lbf-in
20	177
40	354
60	531
80	708
100	885
125	1,106
150	1,328
175	1,549
200	1,770
250	2,213
300	2,655
400	3,540
500	4,425
600	5,310
700	6,196
800	7,081
1,000	8,851
1,200	10,620

Modified



2D DRAWINGS & 3D MODELS
www.WINSMITH.com



Metric Speed Reducers

SOLID SHAFT DIMENSIONS

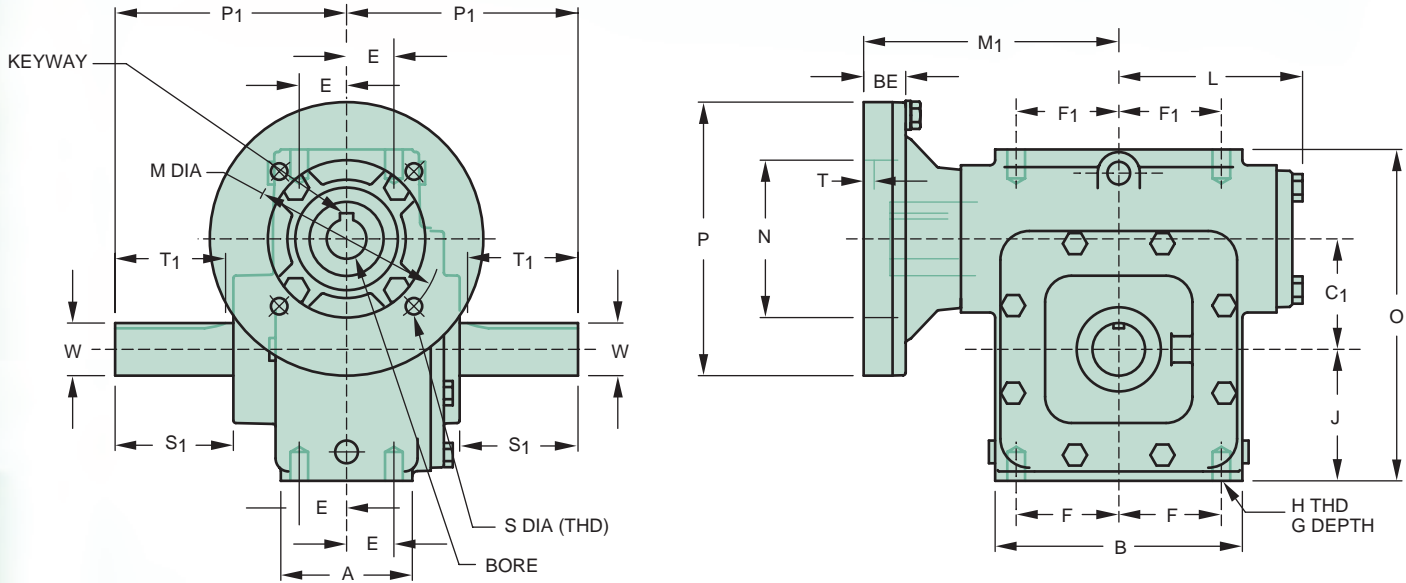

	IEC FRAME (mm)							
	B14 FLANGE				B5 FLANGE			
	63	71	80	90	100/112	132	100/112	132
M	75	85	100	115	130	165	215	265
N	60	70	80	95	110	130	180	230
T	6	6	6	6	6	6	6	6
P	165	165	165	165	165	230	250	300
BE	19	19	19	25	25	33	21	22
S	5.8	7	7	10	10	12	M12	M12
KEYWAY	5x2.3	5x2.3	6x2.8	8x3.3	8x3.3	10x3.3	8x3.3	10x3.3
BORE ⁽¹⁾	14	14	19	24*	28	38	28	38

⁽¹⁾ Bore tolerance 14mm up to and including 28mm is +.020 to +.046
 Bore tolerance for 38mm is +.030 to +.056
 * Note: 24mm bore on sizes E17 & E20, keyway size is 8 x 2.3

Size	DIMENSION (in)												M ₁ DIMENSION (in)						OUTPUT SHAFT DIMENSIONS (mm)					
	A	B	C ₁ in/mm	E	F	F ₁	G DEPTH	H THD	J	L	O	P ₁	B14 FLANGE				B5 FLANGE		W*	S ₁	T ₁	KEYWAY		
													63	71	80	90	100/112	132					100/112	132
E17	2.38	4.63	1.750/44.5	.88	1.94	1.69	.56	3/8-16	2.13	3.44	5.38	4.75	4.50	4.50	4.50	4.75					18	65	56	6 x 3.5
E20	2.38	5.25	2.000/50.8	.88	2.19	1.69	.56	3/8-16	2.13	3.44	5.63	4.75		4.50	4.50	4.75					25	65	56	8 x 4.0
E26	3.13	5.88	2.625/66.7	1.13	2.44	2.44	.63	1/2-13	3.13	4.50	7.88	5.50		5.81	5.81	6.06	6.06		6.19		25	71	62	8 x 4.0
E30	3.50	6.62	3.000/76.2	1.31	2.75	2.75	.75	1/2-13	3.50	4.63	9.00	5.88			6.00	6.25	6.25	6.50	6.38	6.69	28	73	64	8 x 4.0
E35	3.75	7.69	3.500/88.9	1.31	3.25	3.25	1.00	5/8-11	4.00	5.46	10.13	7.00			6.25	6.50	6.50	6.75	6.63	6.94	35	95	86	10 x 5.0
E43	4.38	8.75	4.250/108.0	1.63	3.75	3.75	1.00	5/8-11	4.38	6.28	11.50	8.00				7.31	7.31	7.56	7.44	7.75	42	111	102	12 x 5.0

* Shaft diameter tolerances +0.000 -0.025mm
 Dimensions shown are for construction purposes only. Please contact Winsmith for certified dimension sheets.

Metric Speed Reducers

HOLLOW SHAFT DIMENSIONS

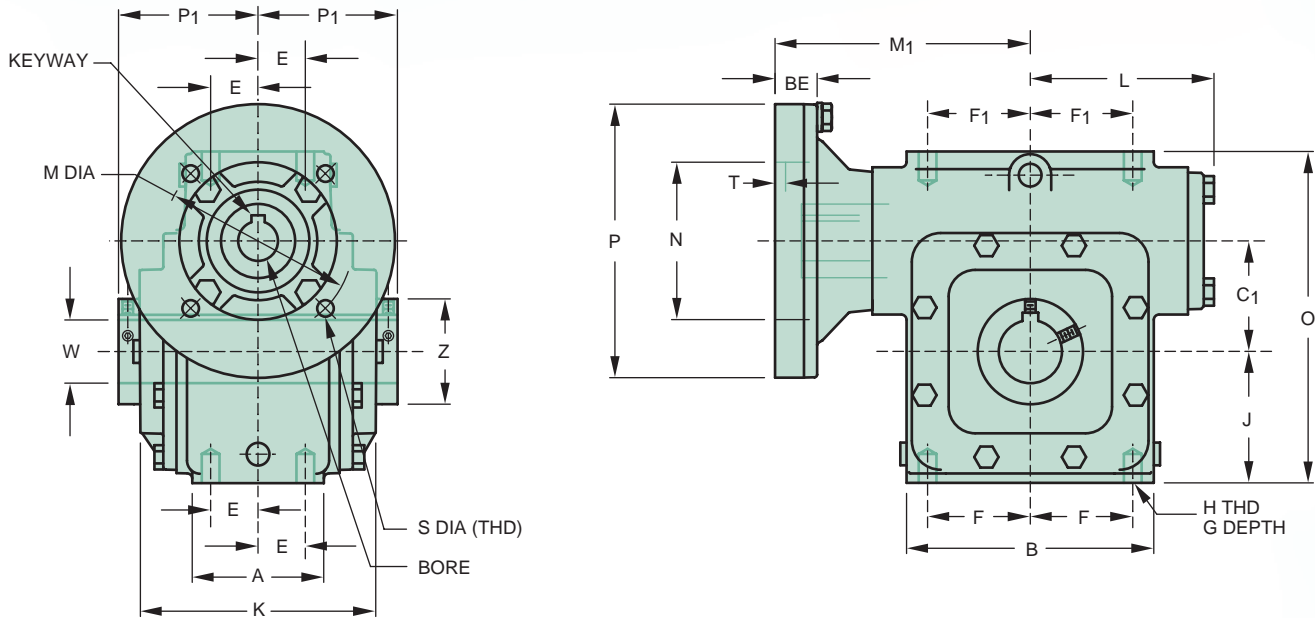

	IEC FRAME (mm)							
	B14 FLANGE						B5 FLANGE	
	63	71	80	90	100/112	132	100/112	132
M	75	85	100	115	130	165	215	265
N	60	70	80	95	110	130	180	230
T	6	6	6	6	6	6	6	6
P	165	165	165	165	165	230	250	300
BE	19	19	19	25	25	33	21	22
S	5.8	7	7	10	10	12	M12	M12
KEYWAY	5x2.3	5x2.3	6x2.8	8x3.3	8x3.3	10x3.3	8x3.3	10x3.3
BORE ⁽¹⁾	14	14	19	24*	28	38	28	38

⁽¹⁾ Bore tolerance 14mm up to and including 28mm is +.020 to +.046
 Bore tolerance for 38mm is +.030 to +.056
 * Note: 24mm bore on sizes E17 & E20, keyway size is 8 x 2.3

Size	DIMENSION (in)													M ₁ DIMENSION (in)						HOLLOW SHAFT OUTPUT BORE (mm)				
	A	B	C ₁ in/mm	E	F	F ₁	G DEPTH	H THD	J	K	L	O	P ₁	Z	B14 FLANGE				B5 FLANGE					
															63	71	80	90	100/112	132	100/112	132	W*	KEYWAY
E17	2.38	4.63	1.750/44.5	.88	1.94	1.69	.56	3/8-16	2.13	2.44	3.44	5.38	3.13	1.49	4.50	4.50	4.50	4.75					18	6 x 2.8
E20	2.38	5.25	2.000/50.8	.88	2.19	1.69	.56	3/8-16	2.13	2.63	3.44	5.63	3.31	2.00		4.50	4.50	4.75					25	8 x 3.3
E26	3.13	5.88	2.625/66.7	1.13	2.44	2.44	.63	1/2-13	3.13	2.81	4.50	7.88	3.50	2.50		5.81	5.81	6.06	6.06		6.19		25	8 x 3.3
E30	3.50	6.62	3.000/76.2	1.31	2.75	2.75	.75	1/2-13	3.50	3.00	4.63	9.00	3.69	2.63			6.00	6.25	6.25	6.50	6.38	6.69	28	8 x 3.3
E35	3.75	7.69	3.500/88.9	1.31	3.25	3.25	1.00	5/8-11	4.00	3.38	5.46	10.13	4.13	2.87			6.25	6.50	6.50	6.75	6.63	6.94	35	10 x 3.3
E43	4.38	8.75	4.250/108.0	1.63	3.75	3.75	1.00	5/8-11	4.38	3.63	6.28	11.50	4.38	3.88				7.31	7.31	7.56	7.44	7.75	42	12 x 3.3

* Bore tolerances +0.000 -0.050mm
 Dimensions shown are for construction purposes only. Please contact Winsmith for certified dimension sheets.



2D DRAWINGS & 3D MODELS
 www.WINSMITH.com



Modified

Modified Output Shaft Options

SE Encore worm gear speed reducer output shafts can be modified to suit the requirements of most applications. These examples depict some of the more

commonly requested modifications. Please contact Winsmith for additional output shaft modification capabilities and requirements.

SOLID OUTPUT SHAFT EXTENSIONS AND MODIFICATIONS

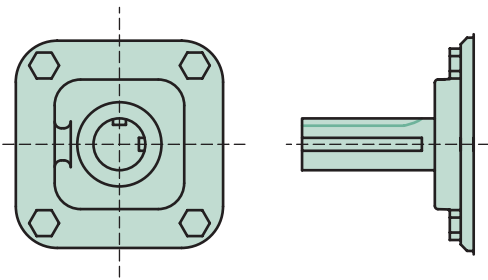

Extra Keyway at 90°

- Secure connection for applications where direction changes are common

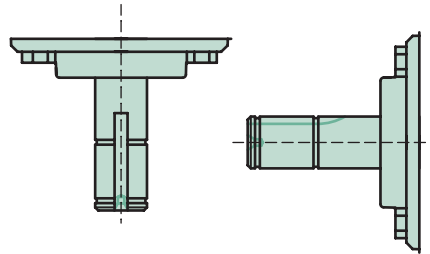

Snap Ring Groove

- Strong position control for attachments

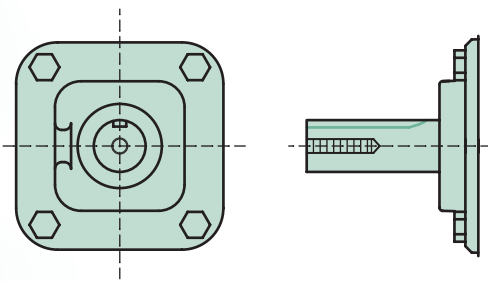

Drilled and Tapped Ends

- Secures end plates or keeper plates to the shaft

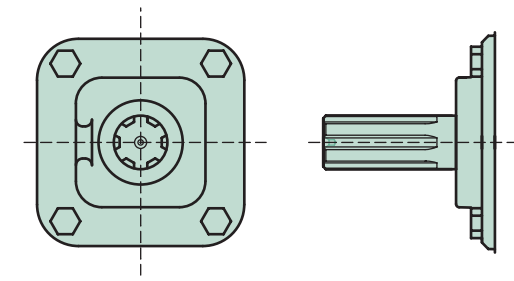

External Spline

- For frequent fitting/dismantling, starts or direction changes

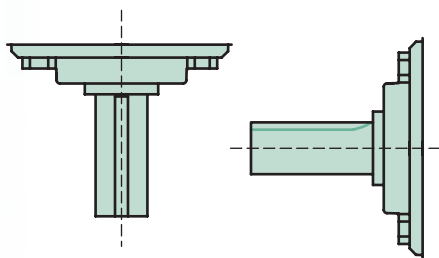

Turned Down Shaft

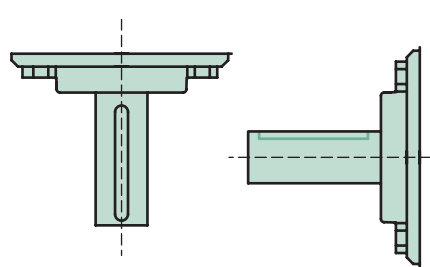

End Milled Keyway

- Captured key for ease of installing the mating components

Modified

Modified Output Shaft Options

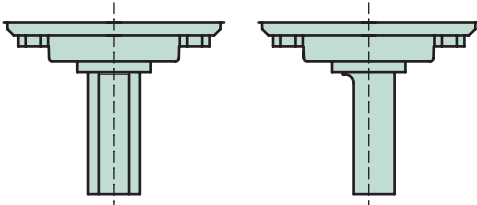

Shaft Flats

- Accommodate a flat in the driven machine

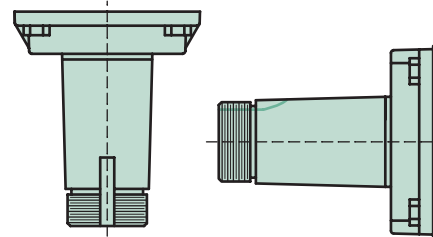

Taper with External Threads

- Eliminates fretting corrosion between two mating shafts

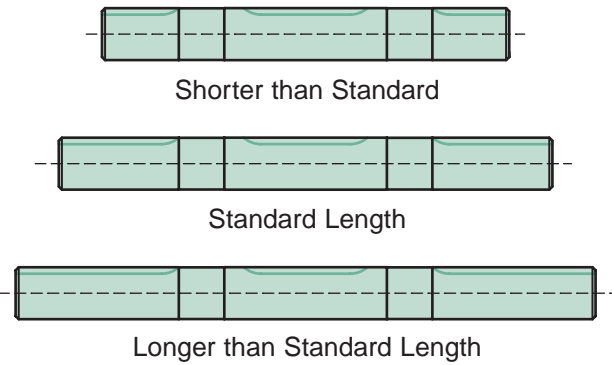

Custom Shaft Lengths

- As required by an application

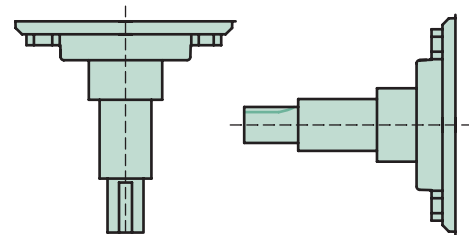

Multiple Step/Turned Down Shafts

- For consistent attachment positioning (pulleys or sprockets)

Optional Materials, Platings & Coatings

Bronze
4140 Hardened Steel
Stainless Steel
Hard Chrome
Thin Dense Chrome
Electroless Nickel



Modified Output Shaft Options

HOLLOW OUTPUT SHAFT MODIFICATIONS

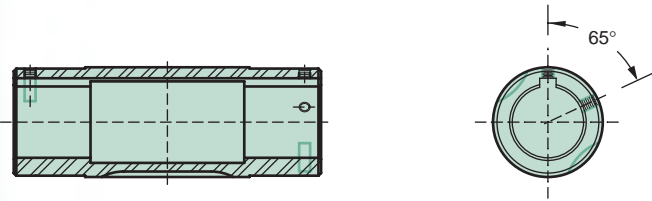

Standard Double Extended (Symmetrical)

- In non-standard sizes including metric dimensions

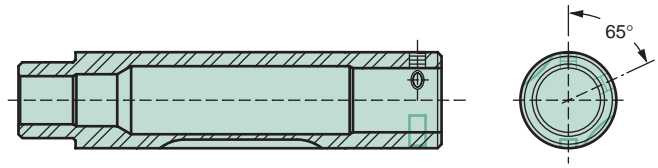

Stepped Shaft for Shrink Disc

- For a shaft locking device

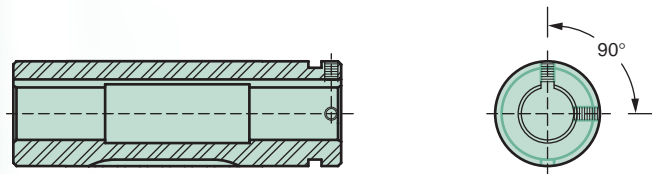

Single Extensions (Asymmetrical)

- Used when a double extended (symmetrical) shaft creates interference

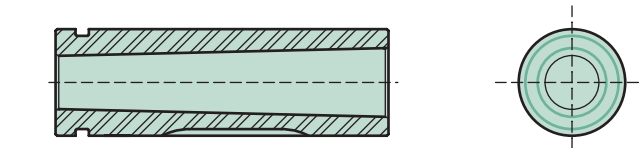

Self Locking Taper

- Eliminates fretting corrosion between two mating shafts

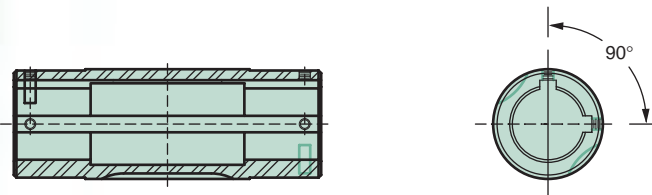

Extra Keyway 90°

- For a more secure connection (for applications where direction changes are common)

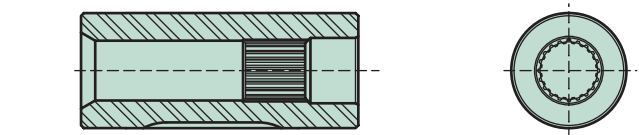

Internal Spline

- For frequent fitting and dismantling or for frequent starts or direction changes

Modified Output Shaft Options

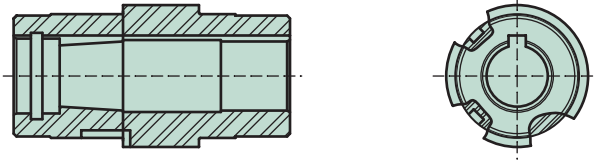

Step Bores, Tapered & Grooved

- Accommodates special shaft requirements

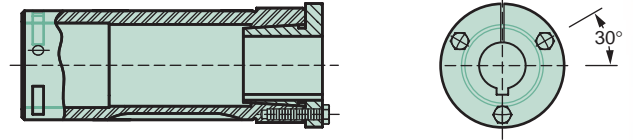

Tapered Bushing Connection

- Provides a rigid shaft connection (see page 128)

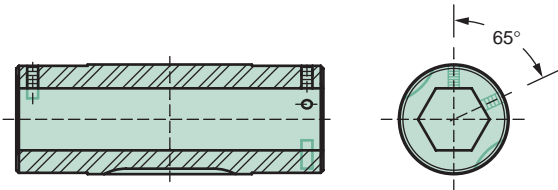

Hex Broach

- Provides shaft engagement without a keyway and easy assembly to standard hex stock

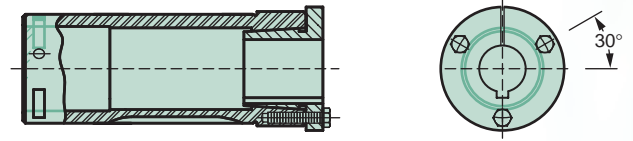

QD® Type Bushing (see page 128)

Optional Materials, Platings & Coatings

- Stainless Steel
- Hard Chrome
- Thin Dense Chrome
- Electroless Nickel

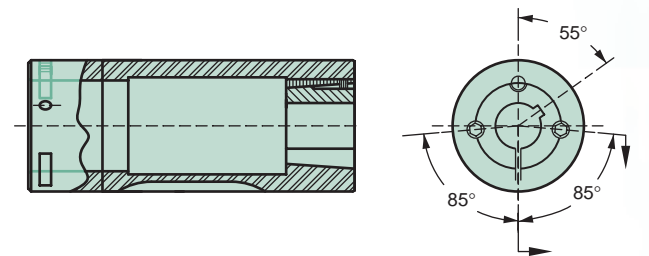

Taper-Lock® Bushing (see page 128)

Taper-Lock® is a registered trademark of Baldor Electric Company.



Shaft Locking Devices

SHRINK DISK

SE Encore hollow output shaft worm gear speed reducers can be equipped with a wide range of shrink disc mounting systems. Shrink disc mounting systems provide a high strength keyless connection between the reducer output shaft and the driven machine shaft. They convert the mechanical/axial force of the bolts to a compressive force, tightening the reducer hollow shaft onto the driven shaft. This “shrinking” creates a “zero” backlash frictional connection between the reducer and the driven shaft that eliminates stress concentrations, coupling backlash, and vulnerability of fatigue failure that is inherent in a keyed connection. Shrink disc mounting systems simplify installation and removal because the high level of surface contact greatly reduces the possibility of fretting corrosion. Additionally, they provide a superior level of torque transmission over a traditional keyed interface. They can be supplied with a key or keyway, mounting directly to the driven shaft, using B-LOC® or another brand.

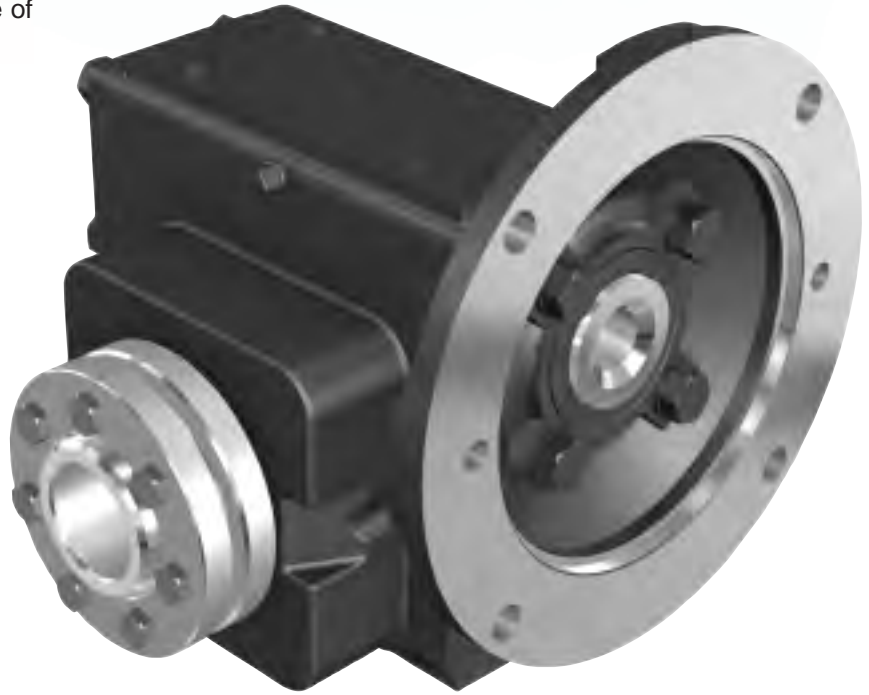

SE ENCORE WITH SHRINK DISK

AVAILABLE SHAFT ARRANGEMENTS AND RELATIVE SHAFT ROTATIONS

XDSS WITH SHRINK DISK

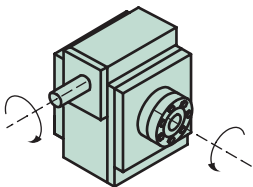

XDSS WITH SHRINK DISK

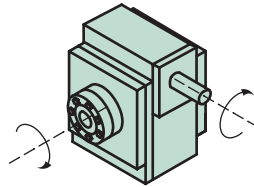

MDSS WITH SHRINK DISK

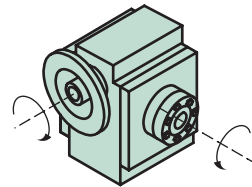

MDSS WITH SHRINK DISK

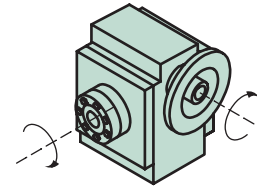

B-Loc® is a registered trademark of Fenner U.S., Incorporated.

Shrink Disks

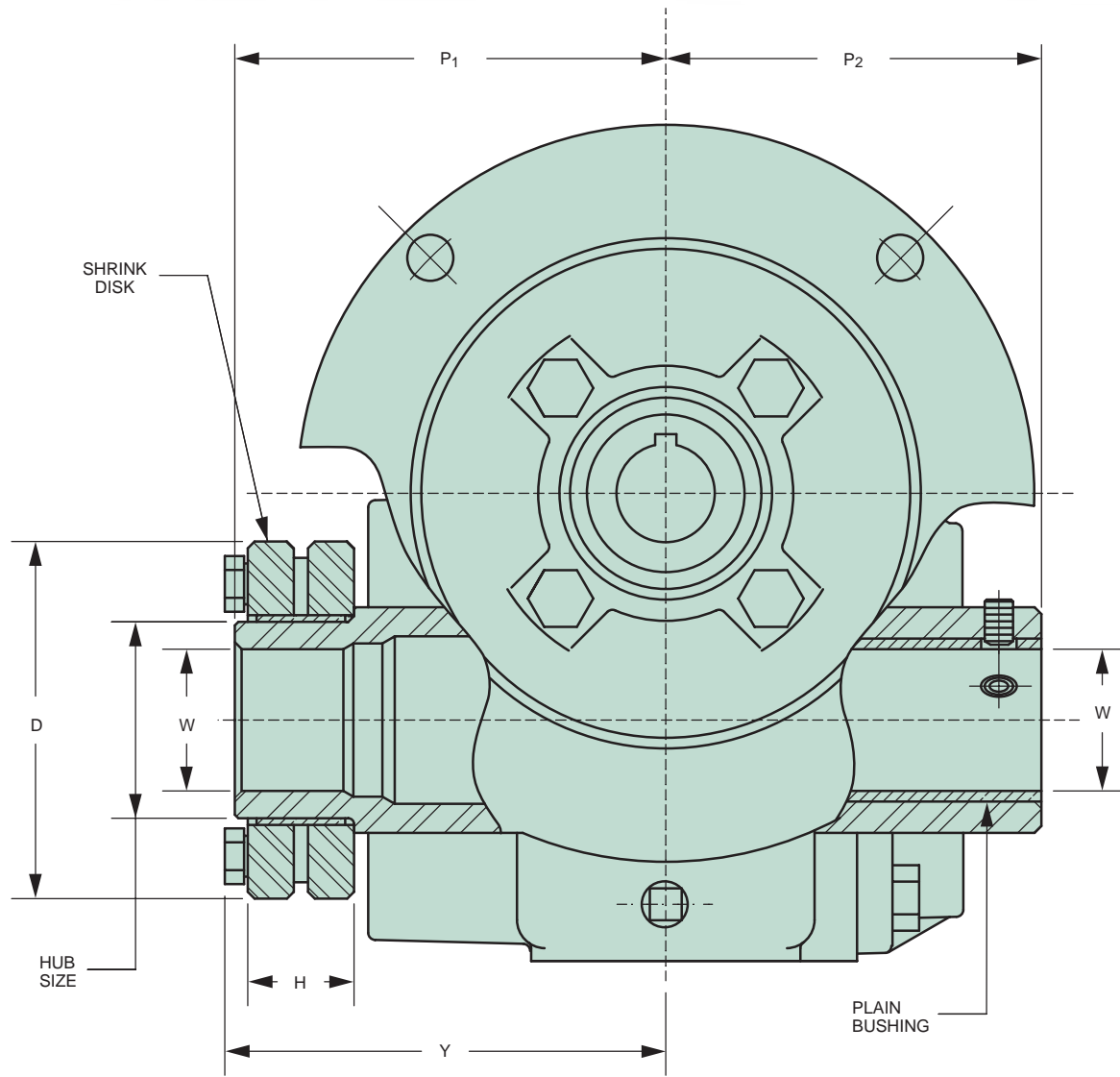

UNIT SIZE	W STANDARD BORES	SHRINK DISK W/S P.N.	SD-10 SHRINK DISK SIZE	SCREW SIZE	SHAFT HUB SIZE +0.002	D	H	P ₁	P ₂	Y MAX
E17	.750	52209	30-10	M5X18	1.181	2.36	.79	3.47	3.13	3.50
E20	1.125 1.188 1.250	52210	44-10	M6X20	1.732	3.15	.94	3.81	3.31	3.85
E24	1.375 1.438	52211	50-10	M6X22	1.969	3.54	1.02	4.01	3.44	4.06
E26	1.375 1.438	52211	50-10	M6X22	1.969	3.54	1.02	4.08	3.50	4.12
E30	1.500 1.625 1.688 1.750	52213	55-10	M6X25	2.165	3.94	1.14	4.38	3.69	4.24
E35	1.875 1.938 2.000	52214	68-10	M6X25	2.677	4.53	1.14	4.78	4.13	4.80
E43	2.438 2.500	52215	80-10	M8X25	3.150	5.71	1.22	5.12	4.38	5.20

Modified



2D DRAWINGS & 3D MODELS
www.WINSMITH.com



Tapered and TAPER-LOCK® Bushings

Two common types of tapered bushings are QD® and Taper-Lock®. Both use tapered wedging to lock onto the shaft. The main difference is that QD bushings have a flange around the outside diameter, while taper lock bushings have straight sides on the outside diameter.

QD bushings are flanged with an internal keyway and are completely split, allowing easy assembly & disassembly. The tapered surface improves grip and minimizes axial movement. Taper-Lock bushings, with their straight sides, use an internal hex head cap screw to drive the bushing into the bore of the hollow shaft.

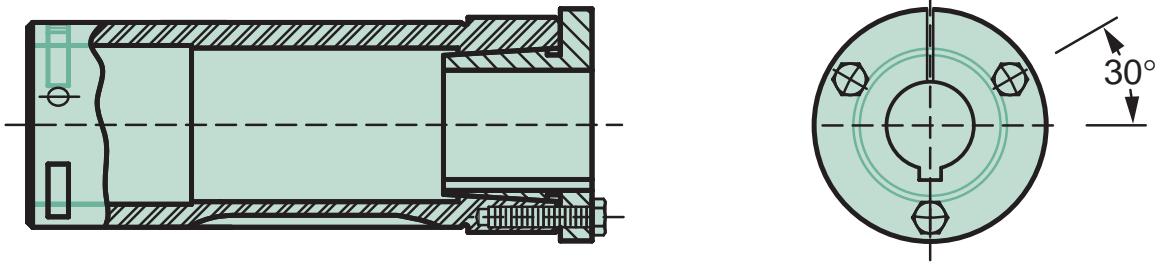

QD® Type (Quick Disconnect) Bushing

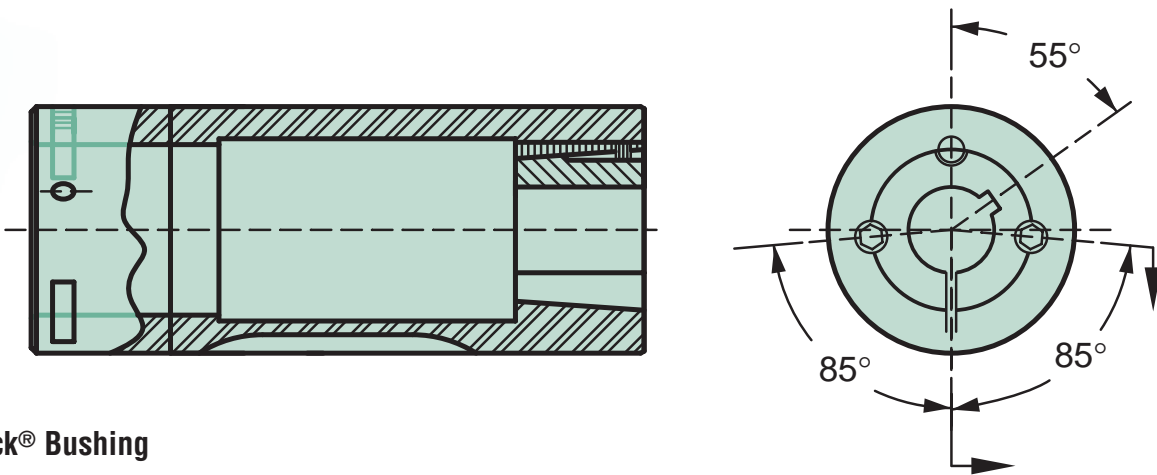

Taper-Lock® Bushing

Modified

Seal Modifications And Combinations

SE Encore worm gear speed reducers incorporate a single seal design that provides superior service for a majority of applications. SE Encore products can also be equipped with specially designed seals made from a variety of materials, for applications with severe requirements.

V-RING SHAFT SEALS

V-ring shaft seals are external flinger seals that protect a primary seal from external contamination. They effectively keep contamination from reaching the primary seal lip thereby extending the primary seal life in harsh environments. The V-ring moves with the shaft providing a “flinger effect” created by centrifugal forces that develop from the shaft rotation. V-ring seals are available on any shaft having enough uninterrupted shaft surface in front of the primary seal to allow proper installation.

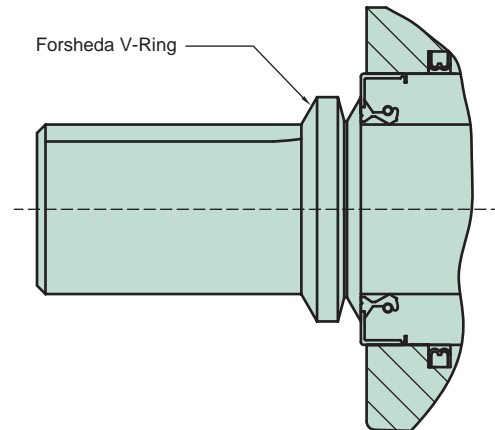

OPPOSED SEALS

In special cases where V-ring shaft seals can not be used, Winsmith recommends double seals in an “opposed” mounting configuration for protection from external contamination. The inner seal faces the bearing and acts as a retainer for the lubricant inside the reducer. The second seal, facing the opposite direction, works to exclude contaminants. Packing the area between the two seals with grease ensures lubrication of the exterior seal.

Seals Opposed

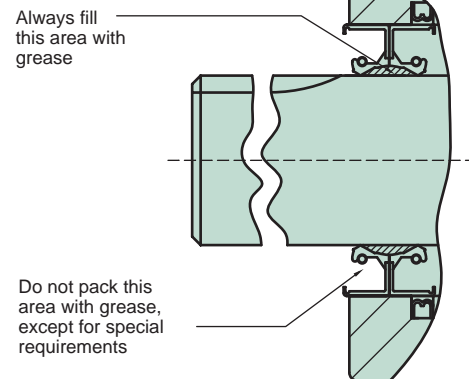

TANDEM SEALS – NOT RECOMMENDED

Winsmith does not recommend the use of tandem seals because this configuration is only proven partially effective as a preventative practice. Further, the use of more than one seal on the input shaft is not recommended because the additional friction created by the second seal increases heat generation, reducing seal life.

Seals Tandem

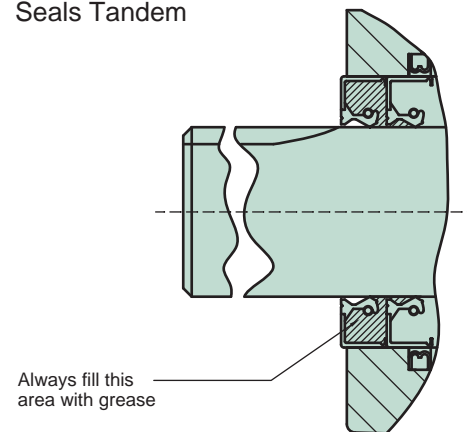

Seal Modifications And Combinations

BEARING ISOLATORS

Bearing isolators are dynamic seals that provide bearing protection and no leakage of lubricant during operation. They also provide total exclusion of outside contaminants. They are comprised of a rotor (rotating) and stator (stationary) member designed with labyrinth type or O-ring construction. Bearing isolators must be used in conjunction with a lip seal. Please contact Winsmith for availability.

OPTIONAL SEAL MATERIALS

A variety of seal materials for applications with excessive requirements are available on SE Encore worm gear speed reducers.

FLUOROELASTOMER (aka, Viton®)

Seals made of Fluoroelastomer materials are designed for improved chemical resistance and higher temperature capabilities when compared to seals made of NBR materials. These seals can be used on any shaft in the SE Encore product line.

PTFE (aka Teflon®)

Seals made from PTFE (Polytetrafluoroethylene) provide a very low coefficient of friction against the shaft and are inert to most chemicals and fluids. Additionally, PTFE seals operate within a wide temperature range and can be augmented with fillers for enhanced wear resistance properties.

OTHER MODIFICATIONS

LONG TERM STORAGE

SE Encore worm gear speed reducers are normally prepared to go into service within a few months of the manufacture date. Products that will be put into storage for six months or more should be prepared for long term storage. This option includes:

- 100% filled with Mobil Glygoyle 460 lubricant. Instructions are provided for draining to the proper operating level prior start-up.
- Shafts and bores are covered with a rust preventative.

SOLID LUBRICANT BEARINGS

In certain speed reducer mounting positions, when there is a concern that some bearings will not receive proper lubrication, a grease fitting is installed to allow external maintenance of these bearings. Occasionally, the application and mounting prohibit accessibility to the lubrication port. In these cases, the bearing can be impregnated with a solid lubricant that will provide adequate lubrication for extended operation. Solid lubricant bearings are available for output shafts only.

Viton® and Teflon® are registered trademarks of E. I. du Pont de Nemours and Company.



2D DRAWINGS & 3D MODELS
www.WINSMITH.com



Modified Accessories

An assortment of special base and bracket mounts are offered in conjunction with the standard mounting accessories that are detailed in the Multimount and Integral sections of this catalog. All SE Encore base mounts, plates, and bracket mounts are covered with the WinGuard Epoxy Coating System. Please contact Winsmith for specific details of these special accessories.

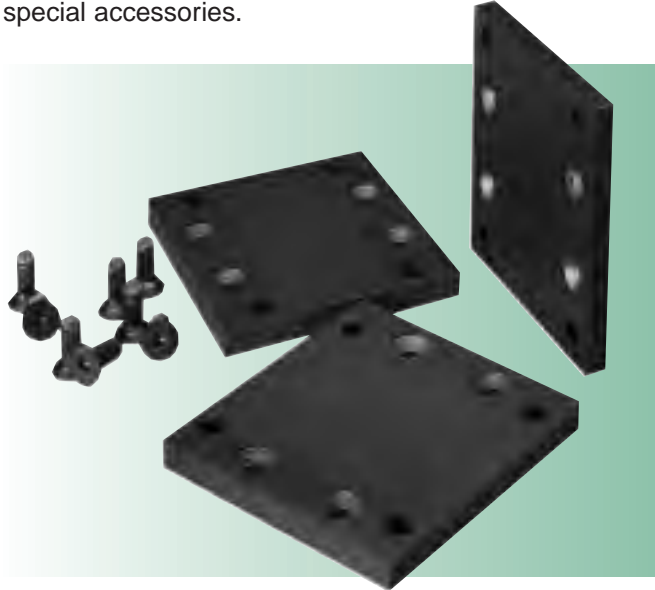

Base Modified to Customer Specifications



Special Hanger Bracket



Custom Bases

COLUMN AND BUTTON VIEW GAUGES

View gauges allow lubricant level monitoring while the speed reducer is in service.

COLUMN VIEW

Column View gauges are constructed of aluminum with a full length view window.

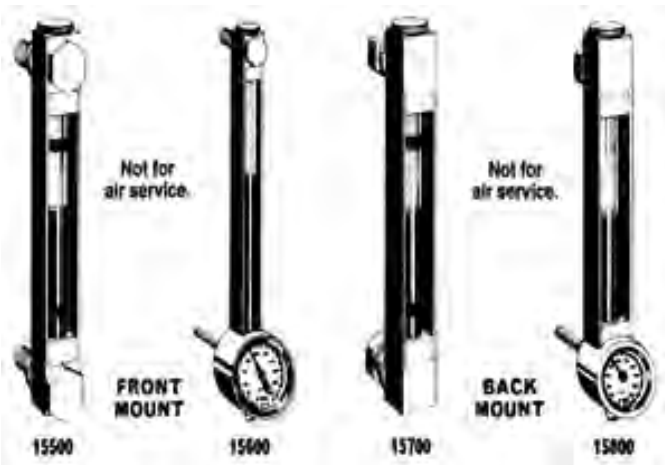

BUTTON (PORTHOLE) GAUGE

Button or Porthole Gauges with NPT tapered threads provide a method for checking the lubricant level in a reducer. An optional internal reflector enhances viewing clarity.

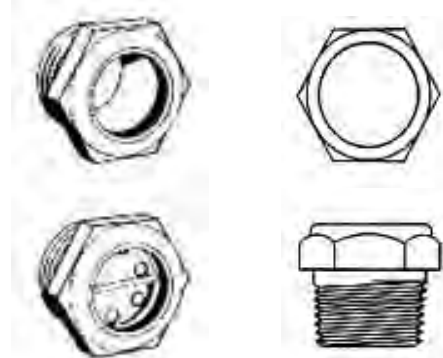

*Images are courtesy of Gits Manufacturing Co.



Special Ratios, Geometry, and Left Hand Gearing

Special ratios offered with the SE Encore product line afford design flexibility that goes beyond typical industry standards. These ratios use unique geometries to achieve a multitude of design requirements including:

- Self-locking,
- Enhanced back driving,
- High shock load tolerance,
- Reduced backlash,
- Hunting tooth. (A special gear geometry that insures any given gear tooth recesses when viewed from a fixed input revolution count. It is often used in fixed, repetitive start/stop applications, where uniform worm gear tooth wear is desired).

A 4:1 reduction is a frequently used special ratio; the ratings are on pages 134-135. Other special ratios include 12.5:1 and 18:1. Page 133 contains a comprehensive chart of special ratios and gear designs available in the SE Encore product line. In addition to the ratios shown, other special ratios and gearing designs are available by contacting Winsmith.

LEFT HAND GEARING

Left hand gearing reverses the rotational direction of an output shaft and is used when other methods, such as changing the motor rotation, are ineffective. Left hand gearing is particularly useful when facilitating a dual drive split power design. The SE Encore ratings are not affected by choosing left hand gearing; the only difference is the rotation direction of the output shaft. Available left hand gearing are shown in the chart.

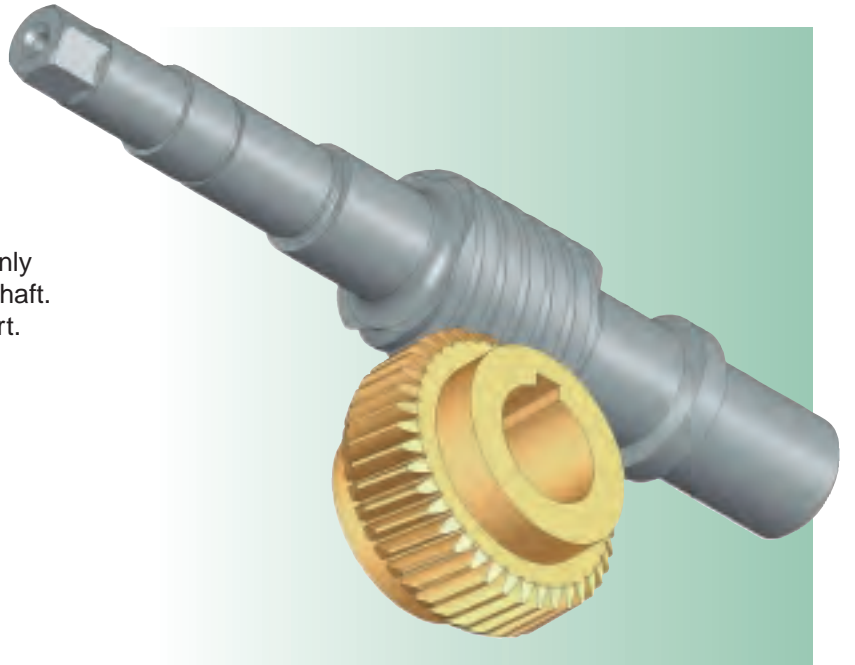
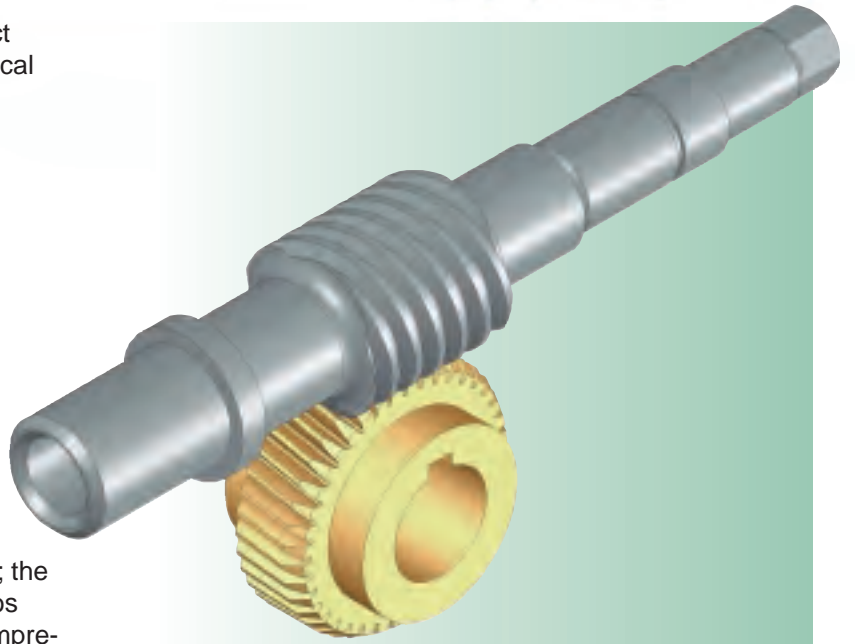

Special Ratios, Geometry, and Left Hand Gearing

SINGLE REDUCTION

RATIO	Size							
	E13	E17	E20	E24	E26	E30	E35	E43
3.5								
4								
4.1666								
5								
6								
6.3333								
6.4								
7								
7.5								
7.75								
8								
8.5								
9								
11								
12								
12.5								
13								
14								
15								
16								
17								
18								
20								
23								
24								
25								
29.5								
30								
31								
32								
35								
36								
37								
39								
40								
45								
50								
53								
57								
60								
70								
71								
82								
84								
90								

DOUBLE REDUCTION (WORM / WORM)

RATIO	Size							
	E13	E17	E20	E24	E26	E30	E35	E43
20								
25								
30								
37.5								
40								
56.25								
60								
73								
75								
80								
85								
90								
100								
112.5								
120								
125								
150								
187.5								
200								
225								
240								
250								
300								
350								
360								
375								
400								
450								
500								
540								
600								
625								
700								
735								
750								
800								
830								
900								
1000								
1200								
1250								
1500								
1600								
1660								
1800								
2000								
2400								
2460								
2475								
2500								
3000								
3200								
3500								
3600								
3960								
4000								
4100								
4800								
4920								
5000								
7920								
8000								
8200								

DOUBLE REDUCTION (HELICAL / WORM)

RATIO	Size							
	E13	E17	E20	E24	E26	E30	E35	E43
38								
44.5								
45.6								
126.7								
151.9								
355.7								
405								
405.3								
486.1								
506.6								
592.9								
607.6								

LEGEND: SPECIAL RATIO SPECIAL GEOMETRY LEFT HAND GEARING



2D DRAWINGS & 3D MODELS
www.WINSMITH.com





4:1 RATIO			HORSEPOWER AND TORQUE RATINGS									OVERHUNG LOAD CAPACITIES (lb)			THRUST LOAD CAPACITIES (lb)	
			MECHANICAL						THERMAL			INPUT SHAFT	OUTPUT SHAFT ^{3,4}		OUTPUT SHAFT ⁵	
SIZE	INPUT RPM ²	OUTPUT RPM	1.00 SERVICE FACTOR			1.25 SERVICE FACTOR		1.50 SERVICE FACTOR		1.00 SERVICE FACTOR		ALL SHAFT INPUT MODELS	SOLID ² SHAFT (e.g. MDNS)	HOLLOW SHAFT (e.g. MDSS)	SOLID SHAFT (e.g. MDNS)	HOLLOW SHAFT (e.g. MDSS)
			INPUT HP	OUTPUT TORQUE (lbf-in.)	EFF	INPUT HP	OUTPUT TORQUE (lbf-in.)	INPUT HP	OUTPUT TORQUE (lbf-in.)	INPUT HP	OUTPUT TORQUE (lbf-in.)					
E13	2500	625	1.30	122	94	1.04	98	0.87	81	1.30	122	200	290	n/a	594	n/a
	1750	438	1.10	149	94	0.88	119	0.73	99	1.10	149					
	1160	290	0.88	179	93	0.70	143	0.59	119	0.88	179					
	870	218	0.73	196	93	0.58	157	0.49	131	0.73	196					
	600	150	0.55	213	92	0.44	170	0.37	142	0.55	213					
	300	75	0.31	233	91	0.25	186	0.21	155	0.31	233					
	100	25	0.11	248	89	0.09	198	0.07	165	0.11	248					
E17	2500	625	2.30	219	95	1.84	175	1.53	146	2.30	219	200	700	700	776	1218
	1750	438	1.98	269	94	1.58	215	1.32	179	1.98	269					
	1160	290	1.65	337	94	1.32	270	1.10	225	1.65	337					
	870	218	1.42	383	93	1.14	306	0.95	255	1.42	383					
	600	150	1.11	431	92	0.89	345	0.74	287	1.11	431					
	300	75	0.65	492	91	0.52	394	0.43	328	0.65	492					
	100	25	0.24	538	88	0.19	430	0.16	359	0.24	538					
E20	2500	625	3.49	335	95	2.79	268	2.33	223	3.19	307	300	700	1100	865	1440
	1750	438	3.00	411	95	2.40	329	2.00	274	3.00	411					
	1160	290	2.50	515	95	2.00	412	1.67	343	2.50	515					
	870	218	2.15	586	94	1.72	469	1.43	391	2.15	586					
	600	150	1.68	660	94	1.34	528	1.12	440	1.68	660					
	300	75	0.98	754	92	0.78	603	0.65	503	0.98	754					
	100	25	0.36	824	90	0.29	659	0.24	549	0.36	824					
E24	2500	625	5.68	548	96	4.54	438	3.79	365	5.68	548	350	1250	1689	909	1909
	1750	438	4.74	653	96	3.79	522	3.16	435	4.74	653					
	1160	290	4.05	840	95	3.24	672	2.70	560	4.05	840					
	870	218	3.45	950	95	2.76	760	2.30	633	3.45	950					
	600	150	2.69	1066	94	2.15	853	1.79	711	2.69	1066					
	300	75	1.55	1212	93	1.24	970	1.03	808	1.55	1212					
	100	25	0.57	1320	92	0.46	1056	0.38	880	0.57	1320					

Note: Ratio shown (4:1) is exact ratio

1. If input speed is below 1160 RPM, please specify speed and mounting position to ensure proper lubrication.
2. Overhung load given at a distance equal to one shaft diameter from the face of the output seal.
3. Overhung load is based on maximum bore size. Use of smaller driven shaft diameter may limit OHL capacity.

4. Overhung loads are based on the output shaft and output bearing capacities only. Check Overhung Load Section for other considerations.

5. Overhung load and thrust load ratings are computed independent of each other. For combined load applications contact Winsmith.

 Mechanical ratings shaded above exceed speed reducer thermal limitations under continuous duty conditions. See the thermal limit columns for continuous duty thermal limit ratings.

Modified



4:1 SINGLE REDUCTION

With Mobil Glygoyle 460 Lubricant

Special
Ratios

4:1 RATIO			HORSEPOWER AND TORQUE RATINGS										OVERHUNG LOAD CAPACITIES (lb)			THRUST LOAD CAPACITIES (lb)	
SIZE	INPUT RPM ²	OUTPUT RPM	MECHANICAL						THERMAL				INPUT SHAFT	OUTPUT SHAFT ^{3,4}		OUTPUT SHAFT ⁵	
			1.00 SERVICE FACTOR			1.25 SERVICE FACTOR			1.50 SERVICE FACTOR		1.00 SERVICE FACTOR		ALL SHAFT INPUT MODELS	SOLID ² SHAFT (e.g. MDNS)	HOLLOW SHAFT (e.g. MDSS)	SOLID SHAFT (e.g. MDNS)	HOLLOW SHAFT (e.g. MDSS)
			INPUT HP	OUTPUT TORQUE (lbf-in.)	EFF	INPUT HP	OUTPUT TORQUE (lbf-in.)	INPUT HP	OUTPUT TORQUE (lbf-in.)	INPUT HP	OUTPUT TORQUE (lbf-in.)						
E26	2500	625	7.20	695	96	5.76	556	4.80	463	6.32	609	500	1250	2177	901	2160	
	1750	438	6.19	852	96	4.95	682	4.13	568	6.19	852						
	1160	290	5.13	1061	95	4.10	849	3.42	707	5.13	1061						
	870	218	4.58	1257	95	3.66	1006	3.05	838	4.58	1257						
	600	150	3.72	1471	94	4.98	1177	2.48	981	3.72	1471						
	300	75	2.25	1751	93	1.80	1401	1.50	1167	2.25	1751						
	100	25	0.86	1967	90	0.69	1574	0.57	1311	0.86	1967						
E30	2500	625	10.80	1051	96	8.64	841	7.20	701	8.85	859	560	1450	2475	1071	2800	
	1750	438	9.30	1289	96	7.44	1031	6.20	859	8.66	1199						
	1160	290	7.62	1585	96	6.10	1268	5.08	1057	7.62	1585						
	870	218	6.91	1908	95	5.53	1526	4.61	1272	6.91	1908						
	600	150	5.70	2268	95	4.56	1814	3.80	1512	5.70	2268						
	300	75	3.51	2748	93	2.81	2198	2.34	1832	3.51	2748						
	100	25	1.36	3123	91	1.09	2498	0.91	2082	1.36	3123						
E35	2500	625	15.40	1499	97	12.32	1199	10.27	999	13.20	1290	750	2550	3600	1777	4000	
	1750	438	13.20	1838	97	10.56	1470	8.80	1225	12.70	1766						
	1160	290	11.10	2324	96	8.88	1859	7.40	1549	11.10	2324						
	870	218	9.78	2714	96	7.82	2171	6.52	1809	9.78	2714						
	600	150	8.25	3298	95	6.60	2638	5.50	2199	8.25	3298						
	300	75	5.20	4095	94	4.16	3276	3.47	2730	5.20	4095						
	100	25	2.05	4730	92	1.64	3784	1.37	3153	2.05	4730						
E43	2500	625	23.80	2334	97	19.04	1867	15.87	1556	21.00	2061	1000	3300	3810	2156	4500	
	1750	438	20.50	2861	97	16.40	2289	13.67	1907	19.80	2766						
	1160	290	17.20	3618	97	13.76	2894	11.47	2412	17.20	3618						
	870	218	15.10	4198	96	12.08	3358	10.07	2799	15.10	4198						
	600	150	12.90	5183	96	10.32	4146	8.60	3455	12.90	5183						
	300	75	8.25	6550	95	6.60	5240	5.50	4368	8.25	6550						
	100	25	3.29	7658	92	2.63	6126	2.19	5105	3.29	7658						

Note: Ratio shown (4:1) is exact ratio
 1. If input speed is below 1160 RPM, please specify speed and mounting position to ensure proper lubrication.
 2. Overhung load given at a distance equal to one shaft diameter from the face of the output seal.
 3. Overhung load is based on maximum bore size. Use of smaller driven shaft diameter may limit OHL capacity.

4. Overhung loads are based on the output shaft and output bearing capacities only. Check Overhung Load Section for other considerations.
 5. Overhung load and thrust load ratings are computed independent of each other. For combined load applications contact Winsmith.
 Mechanical ratings shaded above exceed speed reducer thermal limitations under continuous duty conditions. See the thermal limit columns for continuous duty thermal limit ratings.

Modified



2D DRAWINGS & 3D MODELS
www.WINSMITH.com



Notes

WINSMITH

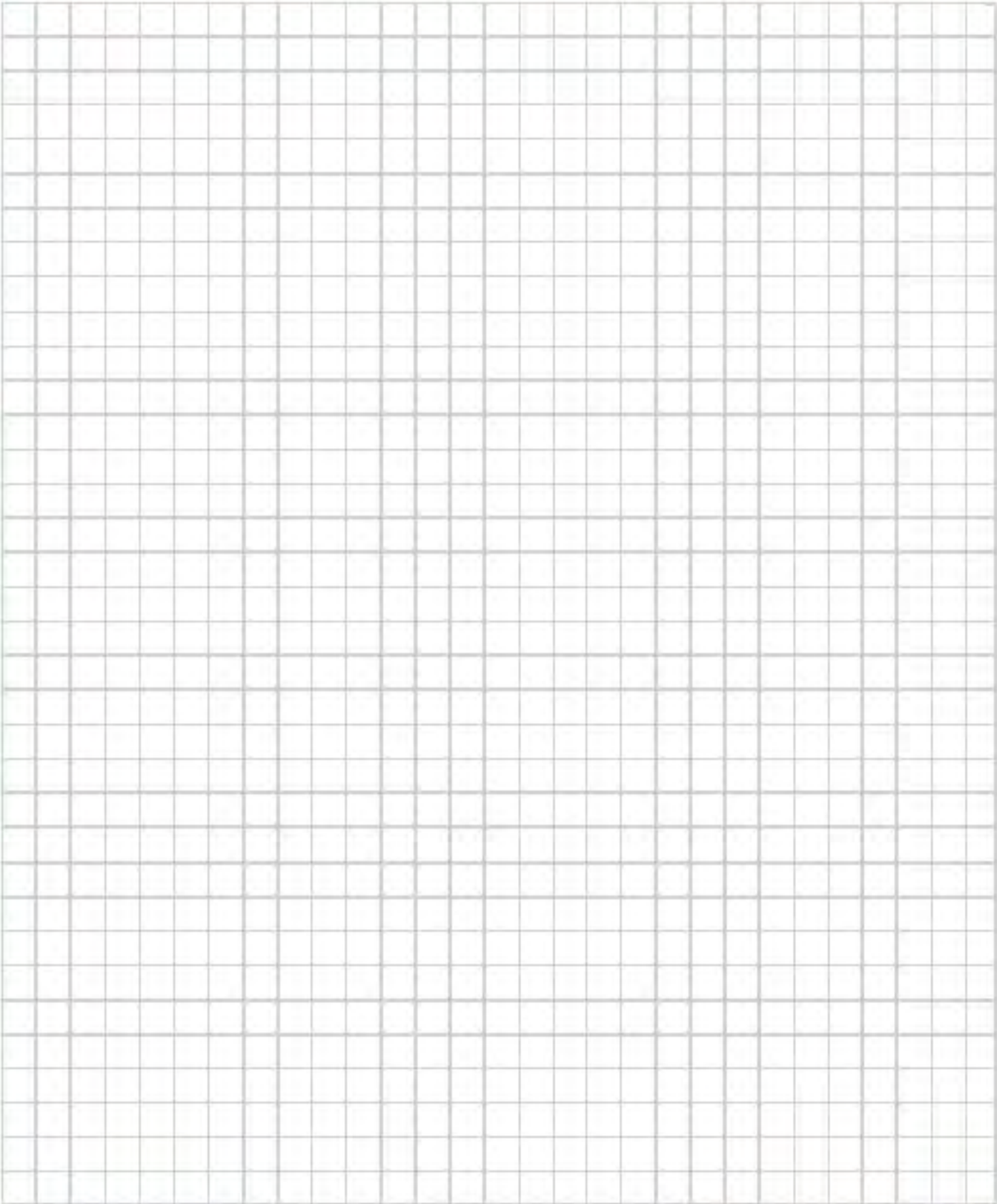

Modified



2D DRAWINGS & 3D MODELS
www.WINSMITH.com



Worm Gear Ratio Multiplier

The Worm Gear Ratio Multiplier features a machined register output flange and shaft that duplicate NEMA C face flange/shaft dimensions. The Worm Gear Ratio Multiplier is available with a solid input shaft, a quill input adaptor or a coupled input adaptor. The following output flange/shaft dimensions are available:

- Sizes E13 and E17 are available with NEMA 56C output flange/shaft dimensions.
- Sizes E17, E20, E24, and E26 are available with NEMA 140TC output flange/shaft dimensions.
- Sizes E24, E26 and E30 are available with NEMA 180TC output flange/shaft dimensions.
- Size E35 is available with NEMA 210TC output flange/shaft dimensions.
- The larger diameter Winsmith standard speed reducer output shafts can also be supplied.

- Register diameter is machined to a NEMA tolerance of 0.003 inches, providing a precision interface with the driven equipment, which can be very useful especially in motion control applications.
- Available in 4, 5, 7.5, 10, 15, 20, 25, 30, 40, 50, 60, 80 and 100:1 ratios and configurable as either a left (L) or a right (R) assembly.
- Completely self-contained ratio multiplier and includes an open-close vent, Mobil Glygoyle 460 lubricant, and the WinGuard Epoxy Coating System.

Coupling the Worm Gear Ratio Multiplier to the input of another NEMA C face reducer provides additional reduction. It also offers an easy method of creating a double reduction reducer on location or when mounting to another piece of NEMA C face equipment such as a brake or a clutch. Various assemblies can be created by mounting it in any one of four positions.

WORM GEAR RATIO MULTIPLIER NOMENCLATURE OVERVIEW

SIZE (Center Distance)	MODEL	RATIO	ASSEMBLY DESIGNATION	QUILL INPUT ADAPTOR	OUTPUT FLANGE
E13 – 1.333"	XDDS	4	Solid Output Shaft	42C	56C
E17 – 1.750"	MDDS	5	R - Right	48C	140TC
E20 – 2.000"	CDDS	7.5	L - Left	56C	180TC
E24 – 2.375"		10		140TC	210TC
E26 – 2.625"		15		180TC	
E30 – 3.000"		20			
E35 – 3.500"		25			
		30			
		40			
		50			
		60			
		80			
		100			

Modified



XDDS Worm Gear Ratio Multiplier



SHIPPING WEIGHTS (lb.) ♦					
MODEL	E13	E17	E20	E24	E26
XDDS	18	22	26	45	49
MDDS	21	25	29	48	52
CDDS	24	29	32	57	62

All motorized weights are for 48C to 140TC adaptor sizes. Add 10% for 180TC/210TC adaptor sizes.

♦Weights are approximate and include shipping carton.

XDDS
Solid Input Shaft
Solid Output Shaft
Flange Mount – NEMA
4.50 Inch Diameter Register



DIMENSIONS

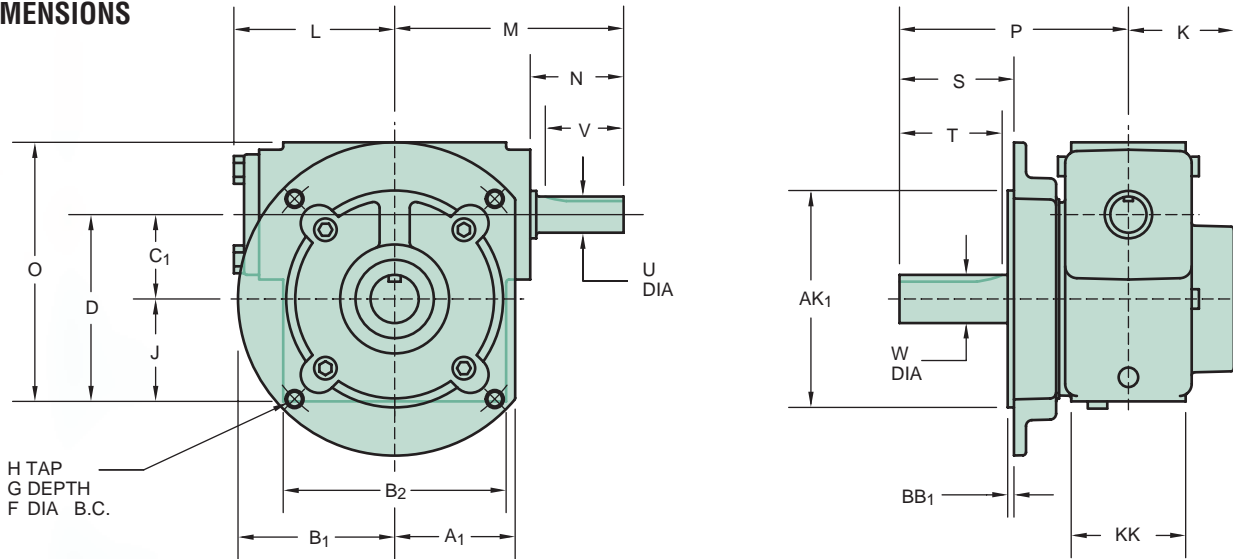

SPEED REDUCER DIMENSIONS (in.)

Size	A ₁	AK ₁ **	B ₁	B ₂	BB ₁	C ₁	D	F DIA	G DEPTH	H TAP	J	K	KK	L	M	O	P	INPUT SHAFT			OUTPUT SHAFT				
																		U*	N	V	KEYWAY	W*	S	T	KEYWAY
E13	2.38	4.500	3.25	3.88	.13	1.333	3.08	5.88	.75	3/8-16	1.75	1.94	2.00	2.83	4.12	4.33	4.56	.625	1.81	1.63	3/16x3/32	.625	2.06	1.81	3/16x3/32
E17	2.50	4.500	3.25	4.63	.13	1.750	3.88	5.88	.88	3/8-16	2.13	2.19	2.38	3.44	4.75	5.38	4.44	.750	1.94	1.69	3/16x3/32	.625°	2.06	1.81	3/16x3/32
E20	2.50	4.500	3.25	5.25	.13	2.000	4.13	5.88	.88	3/8-16	2.13	2.19	2.38	3.44	5.00	5.63	4.50	.750	2.19	1.75	3/16x3/32	.875	2.13	2.00	3/16x3/32
E24	3.25	4.500	3.25	5.38	.13	2.375	5.25	5.88	.75	3/8-16	2.88	2.69	3.13	4.50	6.50	7.25	4.50	1.000	2.75	2.38	1/4x1/8	.875	2.13	2.00	3/16x3/32
E26	3.25	4.500	3.25	5.88	.13	2.625	5.75	5.88	.75	3/8-16	3.13	2.69	3.13	4.50	6.50	7.88	5.50	1.000	2.75	2.38	1/4x1/8	.875°	2.13	2.25	3/16x3/32

* Shaft diameter tolerance =.000 -.001 Dimensions shown are for construction purposes only. Please contact Winsmith for certified dimension sheets.

** Register diameter tolerance +.000-.003°

° Catalog output torque limited to 575 lbf-in.

°° Catalog output torque limited to 1578 lbf-in.

AVAILABLE SHAFT ARRANGEMENTS AND RELATIVE SHAFT ROTATIONS

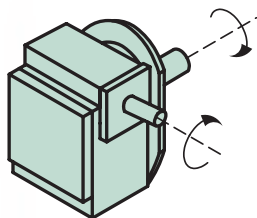

ASSEMBLY R

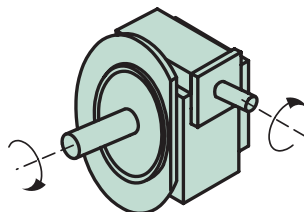

ASSEMBLY L

OPTIONAL OUTPUT SHAFT DIAMETERS (WINSMITH STANDARD)

Size	P	OUTPUT SHAFT			
		W*	S	T	KEYWAY
E13	4.00	.750	2.06	1.81	3/16x3/32
E17	4.75	1.000	2.06	1.81	1/4x1/8
E20	4.75	1.000	2.13	2.00	1/4x1/8
E24	5.50	1.250	2.13	2.00	1/4x1/8
E26	5.50	1.250	2.13	2.25	1/4x1/8

Modified

MDDS - CDDS

MDDS

Quill Input Adaptor
Solid Output Shaft
Flange Mount – NEMA
4.50 Inch Diameter Register



CDDS

Coupled Input Adaptor
Solid Output Shaft
Flange Mount – NEMA
4.50 Inch Diameter Register



DIMENSIONS

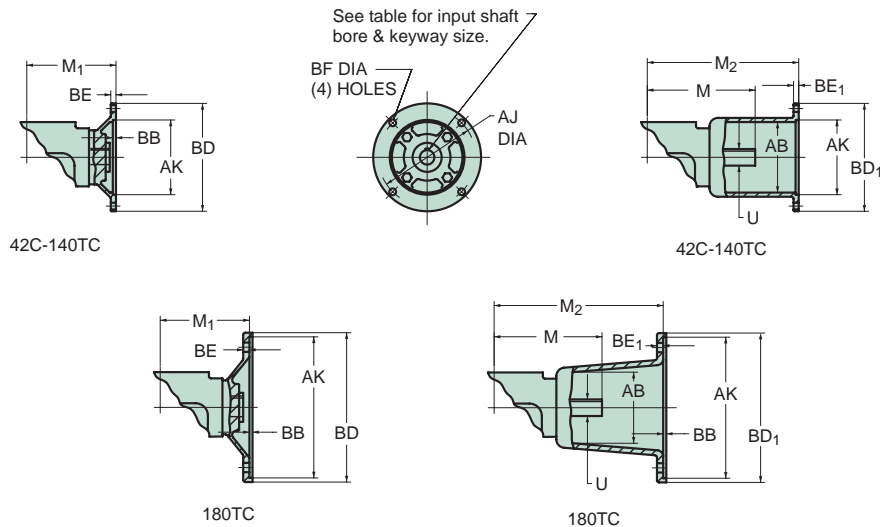

Size	QUILL INPUT ADAPTOR			COUPLED INPUT ADAPTOR											
	M ₁ 42C-48C	M ₁ 56C-140TC	M ₁ 180TC	42C-48TC			56C-140TC			180TC			M	U	KEYWAY
				AB	M ₂	BE ₁	AB	M ₂	BE ₁	AB	M ₂	BE ₁			
E13	3.56	3.63*	NA	2.50	6.81	.38	3.00	6.75	.31	NA			4.13	.625	3/16x3/32
E17	4.06	4.06	NA	2.50	7.56	.38	3.75	7.50	.38	3.75	8.44	.50	4.75	.750	3/16x3/32
E20	4.06	4.06	NA	2.50	7.56	.38	3.75	7.50	.38	3.75	8.44	.50	5.00	.750	3/16x3/32
E24	NA	5.38	5.38	NA	NA	NA	4.13	9.13	.38	4.25	10.19	.50	6.50	1.000	1/4x1/8
E26	NA	5.38	5.38	NA	NA	NA	4.13	9.13	.38	4.25	10.19	.50	6.50	1.000	1/4x1/8

* 56C adaptor only

AVAILABLE SHAFT ARRANGEMENTS AND RELATIVE SHAFT ROTATIONS

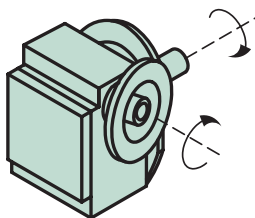

ASSEMBLY R

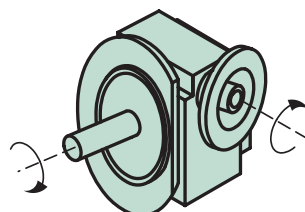

ASSEMBLY L

INPUT ADAPT. DIM.	42C 48C	56C	140TC	180TC
AJ	3.75	5.88	5.88	7.25
AK	3.00	4.50	4.50	8.50
BB	.19	.19	.19	.19
BD	4.50	6.50	6.50	9.00
BD ₁	4.50	6.63	6.63	9.00
BE	.34	.31	.31	.38
BF	.281	.406	.406	.531
KEYWAY	1/8x1/16	3/16x3/32		1/4x1/8
BORE	^{+0.01} _{-.000}	.5005*	.6255	.8755

* 42C adaptor has .3755 bore, 3/32 x 3/64 keyway



2D DRAWINGS & 3D MODELS
www.WINSMITH.com



Modified

XDDS Worm Gear Ratio Multiplier



XDDS
Solid Input Shaft
Solid Output Shaft
Flange Mount – NEMA
8.50 Inch Diameter Register



SHIPPING WEIGHTS (lb.) ♦				
MODEL	E24	E26	E30	E35
XDDS	49	53	54	71
MDDS	52	56	58	75
CDDS	61	66	64	75

All motorized weights are for 48C to 140TC adaptor sizes. Add 10% for 180TC/210TC adaptor sizes.

♦Weights are approximate and include shipping carton.

DIMENSIONS

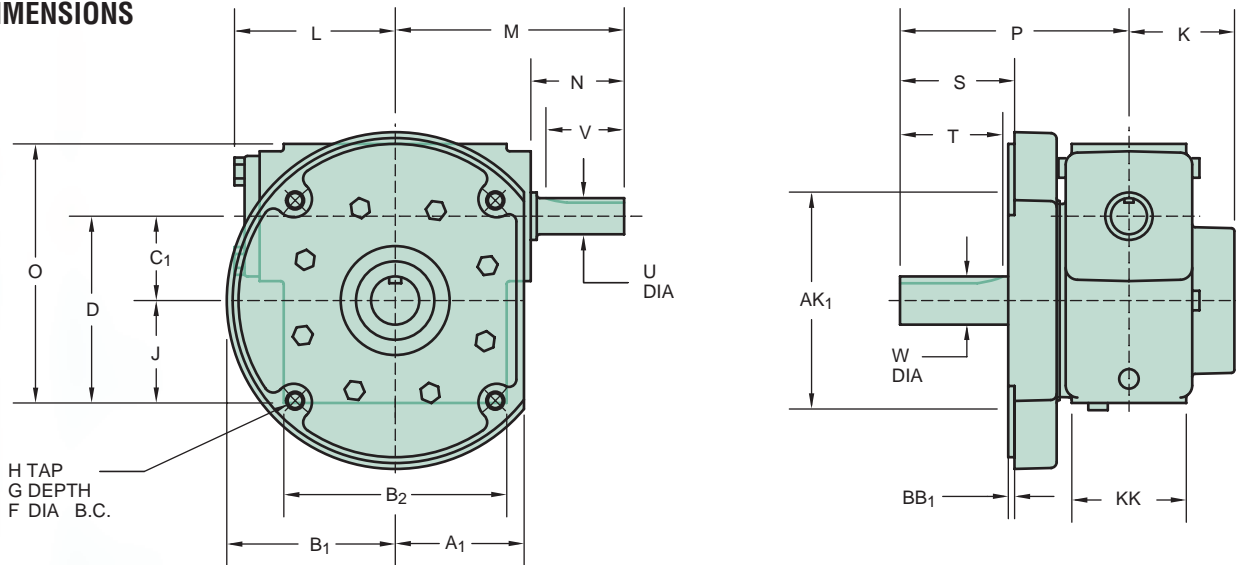

SPEED REDUCER DIMENSIONS (in.)

Size	A ₁	AK ₁ **	B ₁	B ₂	BB ₁	C ₁	D	F DIA	G DEPTH	H TAP	J	K	KK	L	M	O	P	INPUT SHAFT			OUTPUT SHAFT				
																		U*	N	V	KEYWAY	W*	S	T	KEYWAY
E24	3.50	8.500	4.50	5.38	.31	2.375	5.25	7.25	.75	1/2-13	2.88	2.69	3.13	4.50	6.50	7.25	6.13	1.000	2.75	2.38	1/4x1/8	1.125	2.63	3.00	1/4x1/8
E26	3.50	8.500	4.50	5.88	.31	2.625	5.75	7.25	.75	1/2-13	3.13	2.69	3.13	4.50	6.50	7.88	6.13	1.000	2.75	2.38	1/4x1/8	1.125	2.63	3.00	1/4x1/8
E30	3.75	8.500	4.50	6.62	.31	3.000	6.50	7.25	.75	1/2-13	3.50	3.00	3.50	4.63	7.00	9.00	5.88	1.000	3.06	2.38	1/4x1/8	1.125 ^{oo}	2.63	2.50	1/4x1/8
E35	4.13	8.500	4.50	7.69	.31	3.500	7.50	7.25	.75	1/2-13	4.00	3.25	3.75	5.06*	7.38	10.13	7.00	1.000	2.31	2.50	1/4x1/8	1.375	3.13	3.38	5/16x5/32

* Shaft diameter tolerance = .000 -.001 Dimensions shown are for construction purposes only. Please contact Winsmith for certified dimension sheets.

** Register diameter tolerance +.000 -.003"

▲ L Dimension equals 5.46 on MDDS model

^{oo} Catalog output torque limited to 2200 lbf•in.

AVAILABLE SHAFT ARRANGEMENTS AND RELATIVE SHAFT ROTATIONS

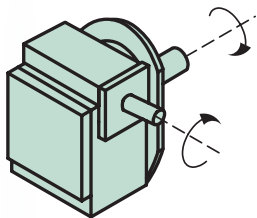

ASSEMBLY R

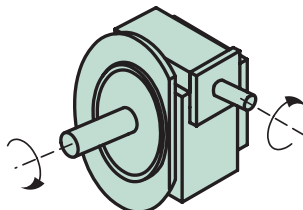

ASSEMBLY L

OPTIONAL OUTPUT SHAFT DIAMETERS (WINSMITH STANDARD)

Size	P	OUTPUT SHAFT			
		W*	S	T	KEYWAY
E24	5.50	1.250	2.00	2.63	1/4x1/8
E26	5.50	1.250	2.00	2.63	1/4x1/8
E30	5.88	1.375	2.63	2.75	5/16x5/32
E35	7.00	1.750	3.13	3.63	3/8x3/16



Modified

MDDS - CDDS

MDDS

Quill Input Adaptor
Solid Output Shaft
Flange Mount – NEMA
8.50 Inch Diameter Register



CDDS

Coupled Input Adaptor
Solid Output Shaft
Flange Mount – NEMA
8.50 Inch Diameter Register



DIMENSIONS

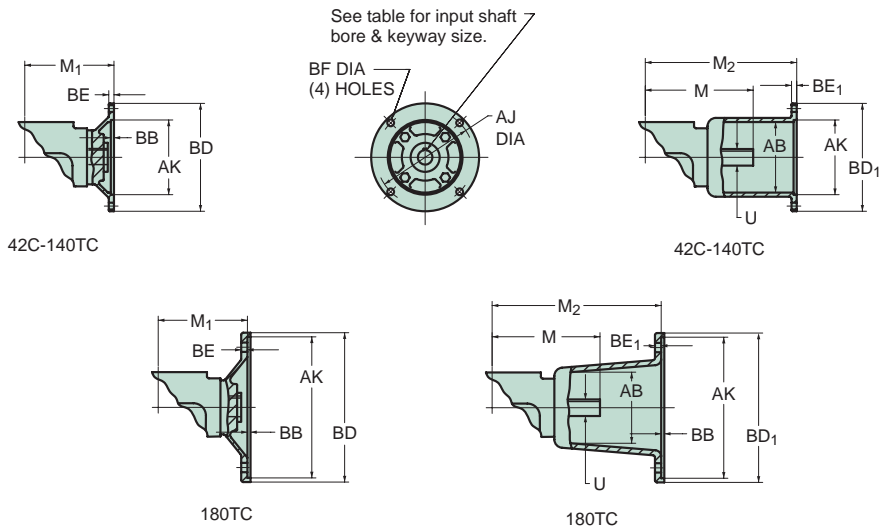

Size	QUILL INPUT ADAPTOR		COUPLED INPUT ADAPTOR								
	M ₁ 56C-140TC	M ₁ 180TC	56C-140TC			180TC			M	U	KEYWAY
			AB	M ₂	BE ₁	AB	M ₂	BE ₁			
E24	5.38	5.38	4.13	9.13	.38	4.25	10.19	.50	6.50	1.000	1/4x1/8
E26	5.38	5.38	4.13	9.13	.38	4.25	10.19	.50	6.50	1.000	1/4x1/8
E30	5.56	5.56	4.13	9.13	.38	4.75	10.88	.50	7.00	1.000	1/4x1/8
E35	5.81	5.81	4.13	9.13	.38	4.75	11.13	.50	7.38	1.000	1/4x1/8

AVAILABLE SHAFT ARRANGEMENTS AND RELATIVE SHAFT ROTATIONS

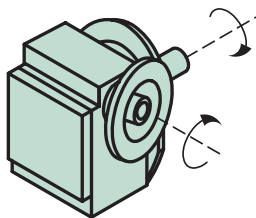

ASSEMBLY R

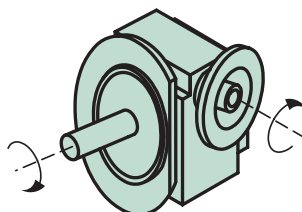

ASSEMBLY L

INPUT ADAPT. DIM.	56C	140TC	180TC
AJ	5.88	5.88	7.25
AK	4.50	4.50	8.50
BB	.19	.19	.19
BD	6.50	6.50	9.00
BD ₁	6.63	6.63	9.00
BE	.31	.31	.38
BF	.406	.406	.531
KEYWAY	3/16x3/32		1/4x1/8
BORE	+001 -000	.6255	.8755
			1.1255



2D DRAWINGS & 3D MODELS
www.WINSMITH.com



Modified

Notes

WINSMITH

Modified

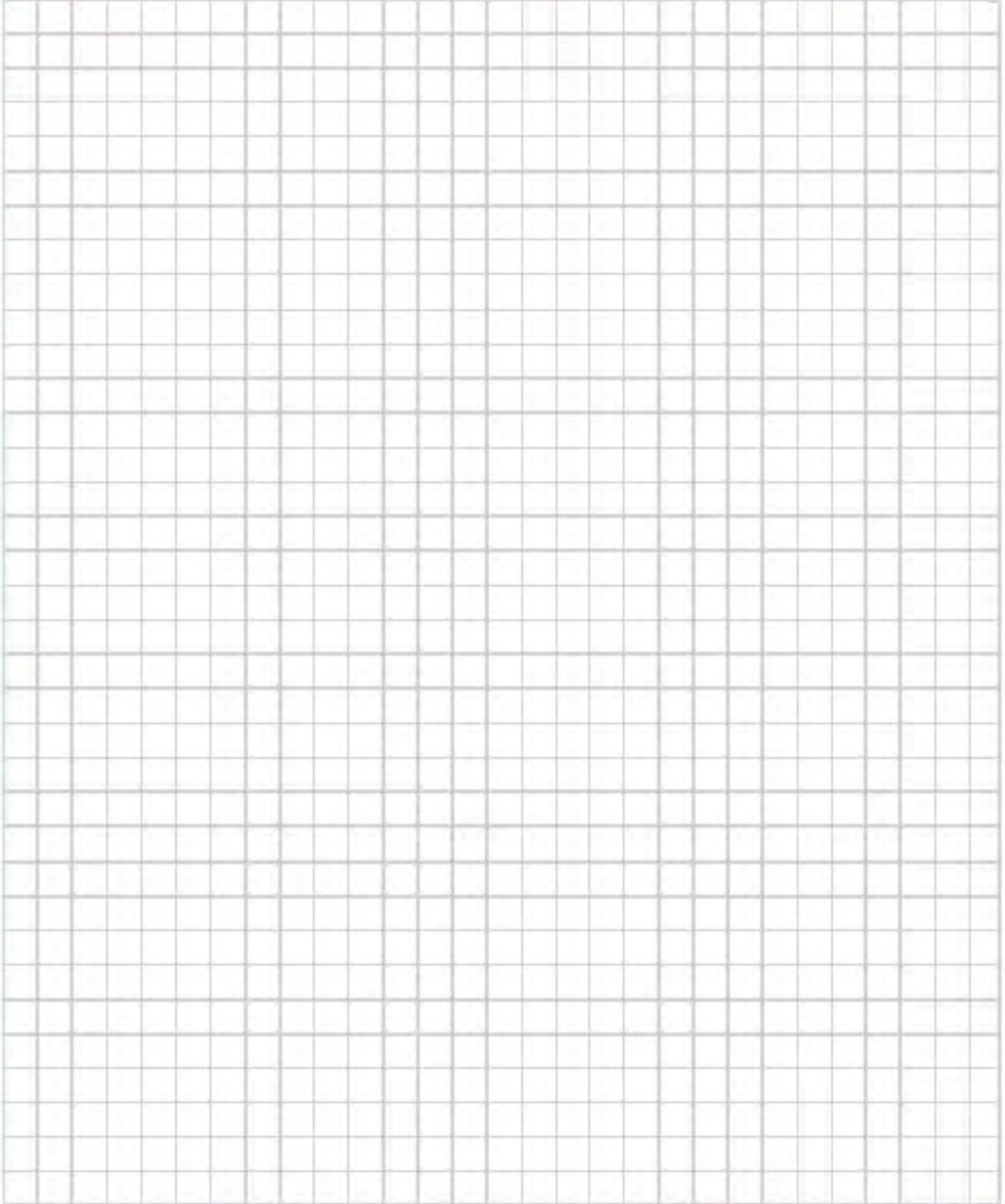

2D DRAWINGS & 3D MODELS
www.WINSMITH.com



Drywell

The SE Encore Drywell utilizes a proven vertical hollow shaft design to ensure that lubricant inside the reducer stays inside the reducer. The internal rotating components are exposed to lubrication while the internal drywell design prevents the oil from contacting the lower output seal or bearing area.

The Drywell reducer configuration is available in three case sizes: E30, E35 & E43. Available ratios are noted in the table at right. Ratings for the three Drywell sizes are included on tables in this section. The lubricant

is not factory installed and is shipped in a separate container with the speed reducer ensuring that the drywell area is not contaminated during transit.

Size	Available Ratio's*
E30	10:1 to 100:1
E35	5:1 to 100:1
E43	5:1 to 100:1

* For other ratios, please contact Winsmith.

DRYWELL CROSS SECTION

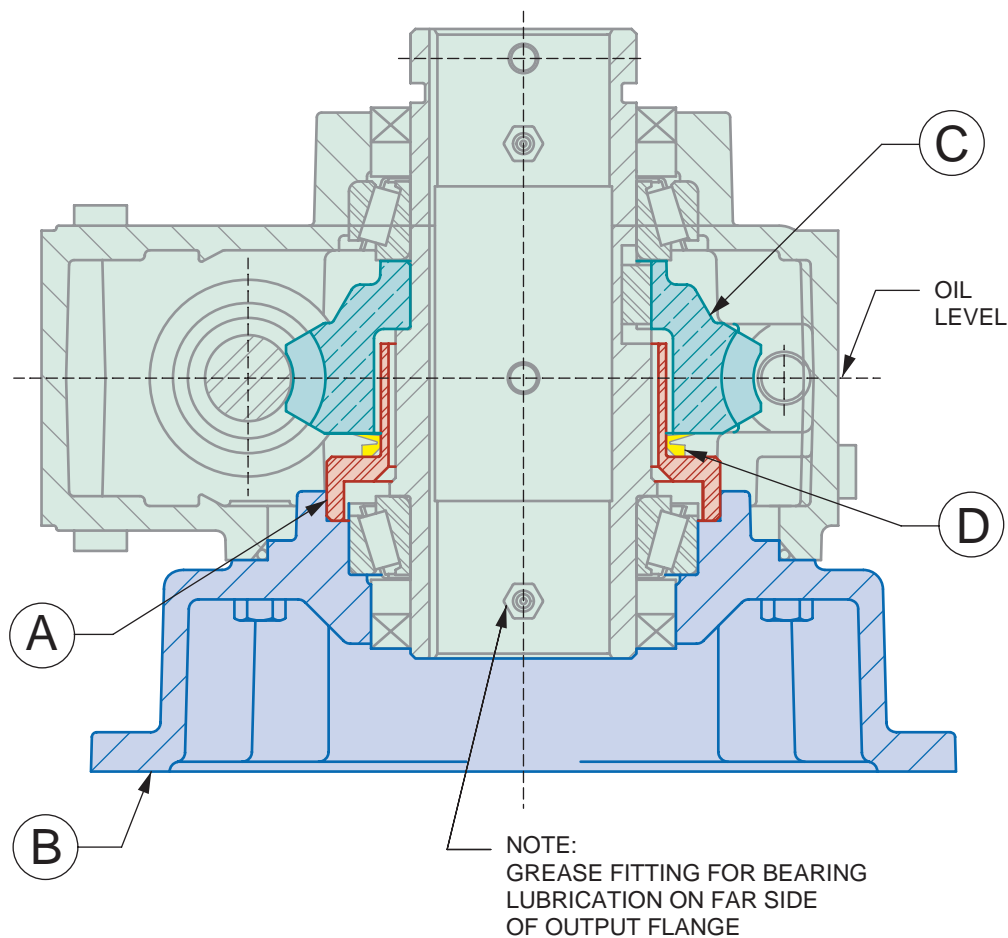

- (A) DRYWELL FLANGE SLEEVE
- (B) OUTPUT FLANGE
- (C) WORM GEAR
- (D) V-RING



XSYS Drywell

XSYS Flange Solid Input Shaft Hollow Output Shaft Flange Mount



SHIPPING WEIGHTS (lb.) ♦			
MODEL	E30	E35	E43
XSYS	71	95	148
MSYS	75	99	153
CSYS	81	105	158

All motorized weights are for 48C to 140TC adaptor sizes. Add 10% for 180TC/210TC adaptor sizes.

♦Weights are approximate and include shipping carton.

DIMENSIONS

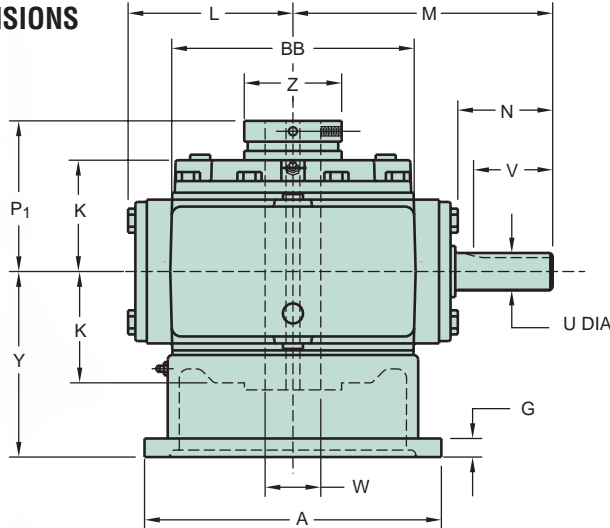

UNITS MAY BE TILTED UP TO 10 DEGREES.
SEE INSTALLATION BULLETIN FOR MORE INFORMATION

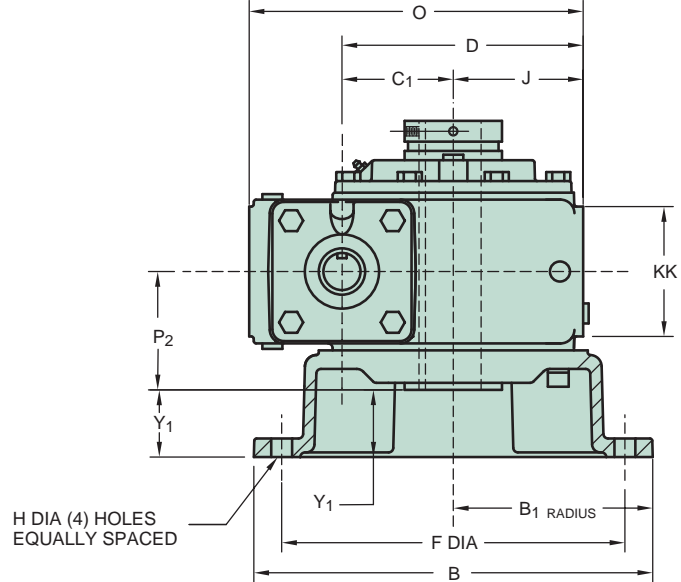

SPEED REDUCER DIMENSIONS (in.)

Size	A	B	B ₁	BB	C ₁	D	F DIA	G	H	J	K	KK	L	M	O	P ₁	P ₂	Y	Y ₁	Z	OUTPUT SHAFT			
																					U*	N	V	KEYWAY
E30	8.00	10.75	5.38	6.62	3.000	6.50	9.250	.50	.563	3.50	3.00	3.50	4.63	7.00	9.00	4.06	3.19	5.00	1.81	2.63	1.000	3.06	2.38	1/4x1/8
E35	9.00	11.00	5.50	7.69	3.500	7.50	10.000	.50	.563	4.00	3.38	3.75	5.06 ⁺	7.38	10.13	4.44	3.56	5.00	1.44	2.87	1.000	2.31	2.50	1/4x1/8
E43	10.50	13.00	6.50	8.75	4.250	4.38	11.500	.63	.688	4.38	4.25	4.38	5.88 ⁺⁺	8.19	11.50	5.00	4.75	5.75	1.00	3.63	1.250	2.31	2.50	1/4x1/8

* Shaft diameter tolerance +.000 -.001

Dimensions shown are for construction purposes only. Please contact Winsmith for certified dimension sheets.

+ L dimension equals 5.46 on E35 MSYS

++ L dimension equals 6.28 on E43 MSYS

AVAILABLE SHAFT ARRANGEMENTS AND RELATIVE SHAFT ROTATIONS

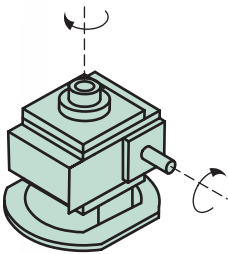

ASSEMBLY DR

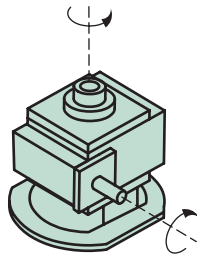

ASSEMBLY DL

HOLLOW OUTPUT SHAFT BORES

(S) Standard Bore (M) Machined to Size Bore (B) Bushing*
*Bushing for use with standard bore only

W**	KEYWAY	E30	E35	E43
1.250	1-1/4	1/4x1/8	M/B	M/B
1.375	1-3/8	5/16x5/32	B	
1.438	1-7/16	3/8x3/16	B	M/B
1.500	1-1/2	3/8x3/16	M/B	M/B
1.625	1-5/8	3/8x3/16		B
1.688	1-11/16	3/8x3/16	M/B	S
1.750	1-3/4	3/8x3/16	B	B
1.875	1-7/8	1/2x1/4	S	B
*1.938	1-15/16	1/2x1/4	S	M/B
2.000	2	1/2x1/4	M/B	S
*2.188	2-3/16	1/2x1/4	S	M/B
2.250	2-1/4	1/2x1/4		B
2.438	2-7/16	5/8x5/16		M/B
2.500	2-1/2	5/8x5/16		B
2.750	2-3/4	5/8x5/16		S

** Bore tolerances +.000 +.002

Two puller slots opposed on all hollow output shafts

* Bore size 1.938 on size E30; keyway is 1/2x3/16

* Bore size 2.188 on size E35; keyway is 1/2x1/8

Contact Winsmith for other bore sizes



Modified

MSYS - CSYS

MSYS
Flange
Quill Input Adaptor
Hollow Output Shaft
Flange Mount



CSYS
Flange
Coupled Input Adaptor
Hollow Output Shaft
Flange Mount



DIMENSIONS

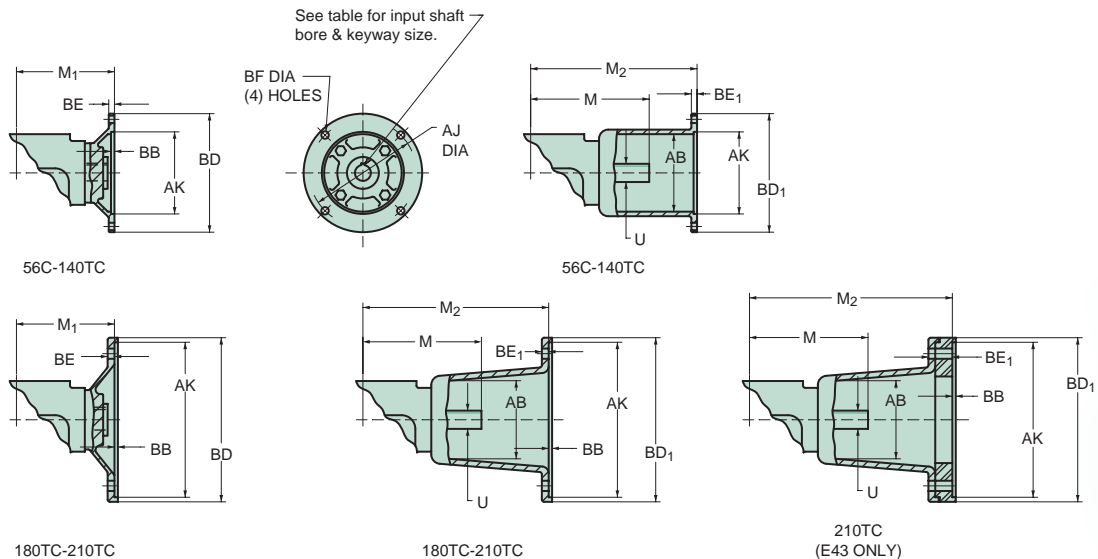

Size	QUILL INPUT ADAPTOR			COUPLED INPUT ADAPTOR											
	M ₁ 56C-140TC	M ₁ 180TC	M ₁ 210TC	56C-140TC			180TC			210TC*			M ₂	U	KEYWAY
	AB	M ₂	BE ₁	AB	M ₂	BE ₁	AB	M ₂	BE ₁						
E30	5.56	5.56	NA	4.13	9.75	.38	4.75	10.88	.50	4.75	10.88	.50	7.00	1.000	1/4x1/8
E35	5.81	5.81	NA	4.13	10.00	.38	4.75	11.13	.50	4.75	11.13	.50	7.38	1.000	1/4x1/8
E43	6.63	6.63	6.63	4.13	10.81	.38	4.75	11.94	.50	4.75	12.88	1.44	8.19	1.250	1/4x1/8

* Adaptor ring furnished with motor adaptor on size E43

AVAILABLE SHAFT ARRANGEMENTS AND RELATIVE SHAFT ROTATIONS

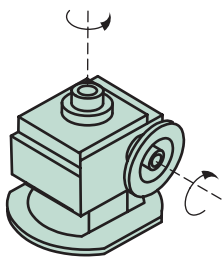

ASSEMBLY DR

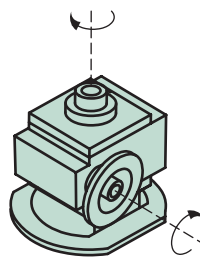

ASSEMBLY DL

INPUT ADAPT. DIM.	56C	140TC	180TC	210TC
AJ	5.88	5.88	7.25	7.25
AK	4.50	4.50	8.50	8.50
BB	.19	.19	.19	.19
BD	6.50	6.50	9.00	9.00
BD ₁	6.63	6.63	9.00	9.00
BE	.31	.31	.38	.38
BF	.406	.406	.531	.531
KEYWAY	3/16x3/32		1/4x1/8	5/16x5/32
BORE +.001 -.000	.6255	.8775	1.1255	1.3755



2D DRAWINGS & 3D MODELS
www.WINSMITH.com



Modified

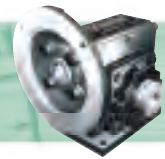

3.000 CENTER DISTANCE			HORSEPOWER AND TORQUE RATINGS								HOLLOW OUTPUT SHAFT OVERHUNG LOAD CAPACITIES (lb) ^{3,4,5}	HOLLOW OUTPUT SHAFT THRUST LOAD CAPACITIES (lb) ⁵	
RATIO ¹	INPUT RPM ²	OUTPUT RPM	MECHANICAL						THERMAL				
			1.00 SERVICE FACTOR			1.25 SERVICE FACTOR		1.50 SERVICE FACTOR	1.00 SERVICE FACTOR				
			INPUT HP	OUTPUT TORQUE (lb ³ -in.)	EFF	INPUT HP	OUTPUT TORQUE (lb ³ -in.)	INPUT HP	OUTPUT TORQUE (lb ³ -in.)	INPUT HP	OUTPUT TORQUE (lb ³ -in.)		
10	2500	250	6.05	1440	94	4.84	1152	4.03	960	6.05	1440	1368	2365
	1750	175	5.16	1748	94	4.13	1398	3.44	1165	5.16	1748		
	1160	116	4.26	2163	94	3.41	1730	2.84	1442	4.26	2163		
	870	87	3.57	2401	93	2.86	1921	2.38	1601	3.57	2401		
	600	60	2.73	2647	92	2.18	2118	1.82	1765	2.73	2647		
	300	30	1.55	2949	91	1.24	2359	1.03	1966	1.55	2949		
	100	10	0.57	3170	88	0.46	2536	0.38	2113	0.57	3170		
15	2500	167	4.49	1570	92	3.59	1256	2.99	1047	4.49	1570	1583	2711
	1750	117	3.84	1910	92	3.07	1528	2.56	1273	3.84	1910		
	1160	77	3.16	2346	91	2.53	1877	2.11	1564	3.16	2346		
	870	58	2.64	2595	91	2.11	2076	1.76	1730	2.64	2595		
	600	40	2.02	2851	90	1.62	2281	1.35	1901	2.02	2851		
	300	20	1.15	3166	88	0.92	2533	0.77	2111	1.15	3166		
	100	7	0.42	3394	85	0.34	2715	0.28	2263	0.42	3394		
20	2500	125	3.52	1609	91	2.82	1287	2.35	1073	3.52	1609	1750	2800
	1750	88	3.01	1959	90	2.41	1567	2.01	1306	3.01	1959		
	1160	58	2.44	2367	89	1.95	1894	1.63	1578	2.44	2367		
	870	44	2.02	2597	89	1.62	2078	1.35	1731	2.02	2597		
	600	30	1.54	2831	88	1.23	2265	1.03	1887	1.54	2831		
	300	15	0.87	3116	86	0.70	2493	0.58	2077	0.87	3116		
	100	5	0.32	3322	83	0.26	2658	0.21	2215	0.32	3322		
25	2500	100	2.80	1571	89	2.24	1257	1.87	1047	2.80	1571	1890	2800
	1750	70	2.47	1968	89	1.98	1574	1.65	1312	2.47	1968		
	1160	46	1.97	2349	88	1.58	1879	1.31	1566	1.97	2349		
	870	35	1.63	2563	87	1.30	2050	1.09	1709	1.63	2563		
	600	24	1.24	2780	86	0.99	2224	0.83	1853	1.24	2780		
	300	12	0.69	3042	84	0.55	2434	0.46	2028	0.69	3042		
	100	4	0.25	3230	81	0.20	2584	0.17	2153	0.25	3230		
30	2500	83	2.49	1634	87	1.99	1307	1.66	1089	2.49	1634	2020	2800
	1750	58	2.14	1989	86	1.71	1591	1.43	1326	2.14	1989		
	1160	39	1.75	2429	85	1.40	1943	1.17	1619	1.75	2429		
	870	29	1.47	2680	84	1.18	2144	0.98	1787	1.47	2680		
	600	20	1.13	2936	83	0.90	2349	0.75	1957	1.13	2936		
	300	10	0.64	3250	80	0.51	2600	0.43	2167	0.64	3250		
	100	3	0.24	3478	77	0.19	2782	0.16	2319	0.24	3478		

1. Exact ratio
 2. If input speed is below 1160 RPM, please specify speed and mounting position to ensure proper lubrication.
 3. Overhung load is based on maximum bore size. Use of smaller driven shaft diameter may limit OHL capacity.

4. Overhung load limits are based on the output shaft and bearing capacities. Check overhung load section for other considerations.
 5. Overhung load and thrust load ratings are computed independent of each other. For combined load applications, contact Winsmith.

Modified



DRYWELL SINGLE REDUCTION

With Mobil Glygoyle 460 Lubricant



3.000 CENTER DISTANCE			HORSEPOWER AND TORQUE RATINGS								HOLLOW OUTPUT SHAFT OVERHUNG LOAD CAPACITIES (lb) ^{3,4,5}	HOLLOW OUTPUT SHAFT THRUST LOAD CAPACITIES (lb) ⁵	
RATIO ¹	INPUT RPM ²	OUTPUT RPM	MECHANICAL						THERMAL				
			1.00 SERVICE FACTOR			1.25 SERVICE FACTOR		1.50 SERVICE FACTOR	1.00 SERVICE FACTOR				
			INPUT HP	OUTPUT TORQUE (lbf-in.)	EFF	INPUT HP	OUTPUT TORQUE (lbf-in.)	INPUT HP	OUTPUT TORQUE (lbf-in.)	INPUT HP	OUTPUT TORQUE (lbf-in.)		
40	2500	63	1.91	1616	84	1.53	1293	1.27	1077	1.91	1616	2220	2800
	1750	44	1.64	1967	83	1.31	1574	1.09	1311	1.64	1967		
	1160	29	1.33	2367	82	1.06	1894	0.89	1578	1.33	2367		
	870	22	1.11	2593	81	0.89	2074	0.74	1729	1.11	2593		
	600	15	0.85	2822	80	0.68	2258	0.57	1881	0.85	2822		
	300	8	0.48	3101	77	0.38	2481	0.32	2067	0.48	3101		
	100	3	0.18	3301	74	0.14	2641	0.12	2201	0.18	3301		
50	2500	50	1.49	1523	81	1.19	1218	0.99	1015	1.49	1523	2350	2800
	1750	35	1.31	1902	81	1.05	1522	0.87	1268	1.31	1902		
	1160	23	1.05	2264	79	0.84	1811	0.70	1509	1.05	2264		
	870	17	0.87	2467	78	0.70	1974	0.58	1645	0.87	2467		
	600	12	0.66	2673	77	0.53	2138	0.44	1782	0.66	2673		
	300	6	0.37	2921	74	0.30	2337	0.25	1947	0.37	2921		
	100	2	0.14	3099	71	0.11	2479	0.09	2066	0.14	3099		
60	2500	42	1.23	1452	78	0.98	1162	0.82	968	1.23	1452	2580	2800
	1750	29	1.07	1796	78	0.86	1437	0.71	1197	1.07	1796		
	1160	19	0.85	2124	77	0.68	1699	0.57	1416	0.85	2124		
	870	15	0.70	2306	76	0.56	1845	0.47	1537	0.70	2306		
	600	10	0.53	2490	74	0.42	1992	0.35	1660	0.53	2490		
	300	5	0.30	2712	72	0.24	2170	0.20	1808	0.30	2712		
	100	2	0.11	2798	69	0.09	2238	0.07	1865	0.11	2798		
80	2500	31	0.83	1206	72	0.66	965	0.55	804	0.83	1206	2580	2800
	1750	22	0.71	1478	73	0.57	1182	0.47	985	0.71	1478		
	1160	15	0.56	1734	72	0.45	1387	0.37	1156	0.56	1734		
	870	11	0.46	1876	71	0.37	1501	0.31	1251	0.46	1876		
	600	8	0.34	2018	70	0.27	1614	0.23	1345	0.34	2018		
	300	4	0.18	2050	67	0.14	1640	0.12	1367	0.18	2050		
	100	1	0.06	2050	64	0.05	1640	0.04	1367	0.06	2050		
100	2500	25	0.57	951	66	0.46	761	0.38	634	0.57	951	2580	2800
	1750	18	0.48	1160	67	0.38	928	0.32	773	0.48	1160		
	1160	12	0.37	1356	67	0.30	1085	0.25	904	0.37	1356		
	870	9	0.31	1464	66	0.25	1171	0.21	976	0.31	1464		
	600	6	0.23	1572	65	0.18	1258	0.15	1048	0.23	1572		
	300	3	0.13	1696	63	0.10	1357	0.09	1131	0.13	1696		
	100	1	0.04	1696	61	0.03	1357	0.03	1131	0.04	1696		

1. Exact ratio
 2. If input speed is below 1160 RPM, please specify speed and mounting position to ensure proper lubrication.
 3. Overhung load is based on maximum bore size. Use of smaller driven shaft diameter may limit OHL capacity.

4. Overhung load limits are based on the output shaft and bearing capacities. Check overhung load section for other considerations.
 5. Overhung load and thrust load ratings are computed independent of each other. For combined load applications, contact Winsmith.

Modified



2D DRAWINGS & 3D MODELS
www.WINSMITH.com





3.500 CENTER DISTANCE			HORSEPOWER AND TORQUE RATINGS								HOLLOW OUTPUT SHAFT OVERHUNG LOAD CAPACITIES (lb) ^{3,4,5}	HOLLOW OUTPUT SHAFT THRUST LOAD CAPACITIES (lb) ⁵	
			MECHANICAL				THERMAL						
RATIO ¹	INPUT RPM ²	OUTPUT RPM	1.00 SERVICE FACTOR		1.25 SERVICE FACTOR		1.50 SERVICE FACTOR		1.00 SERVICE FACTOR				
			INPUT HP	OUTPUT TORQUE (lb•in.)	EFF	INPUT HP	OUTPUT TORQUE (lb•in.)	INPUT HP	OUTPUT TORQUE (lb•in.)	INPUT HP	OUTPUT TORQUE (lb•in.)		
5	2500	500	13.48	1637	96	10.78	1310	8.99	1091	12.71	1543	1447	2246
	1750	350	11.60	2007	96	9.28	1606	7.73	1338	11.60	2007		
	1160	232	9.78	2539	96	7.82	2031	6.52	1693	9.78	2539		
	870	174	8.63	2972	95	6.90	2378	5.75	1981	8.63	2972		
	600	120	7.18	3559	94	5.74	2847	4.79	2373	7.18	3559		
	300	60	4.46	4348	93	3.57	3478	2.97	2899	4.46	4348		
	100	20	1.74	4969	91	1.39	3975	1.16	3313	1.74	4969		
7.5	2500	333	10.47	1895	96	8.38	1516	6.98	1263	10.47	1895	1582	2612
	1750	233	9.02	2323	95	7.22	1858	6.01	1549	9.02	2323		
	1160	155	7.55	2917	95	6.04	2334	5.03	1945	7.55	2917		
	870	116	6.60	3379	94	5.28	2703	4.40	2253	6.60	3379		
	600	80	5.26	3875	94	4.21	3100	3.51	2583	5.26	3875		
	300	40	3.12	4512	92	2.50	3610	2.08	3008	3.12	4512		
	100	13	1.18	4993	90	0.94	3994	0.79	3329	1.18	4993		
10	2500	250	8.57	2048	95	6.86	1638	5.71	1365	8.57	2048	1734	2903
	1750	175	7.38	2511	94	5.90	2009	4.92	1674	7.38	2511		
	1160	116	6.19	3152	94	4.95	2522	4.13	2101	6.19	3152		
	870	87	5.36	3612	93	4.29	2890	3.57	2408	5.36	3612		
	600	60	4.23	4101	92	3.38	3281	2.82	2734	4.23	4101		
	300	30	2.48	4722	91	1.98	3778	1.65	3148	2.48	4722		
	100	10	0.94	5187	88	0.75	4150	0.63	3458	0.94	5187		
15	2500	167	6.31	2217	93	5.05	1774	4.21	1478	6.31	2217	1998	3339
	1750	117	5.45	2717	92	4.36	2174	3.63	1811	5.45	2717		
	1160	77	4.57	3408	91	3.66	2726	3.05	2272	4.57	3408		
	870	58	3.95	3887	91	3.16	3110	2.63	2591	3.95	3887		
	600	40	3.12	4394	90	2.50	3515	2.08	2929	3.12	4394		
	300	20	1.83	5035	87	1.46	4028	1.22	3357	1.83	5035		
	100	7	0.69	5514	84	0.55	4411	0.46	3676	0.69	5514		
20	2500	125	4.95	2278	91	3.96	1822	3.30	1519	4.95	2278	2204	3660
	1750	88	4.18	2730	91	3.34	2184	2.79	1820	4.18	2730		
	1160	58	3.57	3477	90	2.86	2782	2.38	2318	3.57	3477		
	870	44	3.04	3917	89	2.43	3134	2.03	2611	3.04	3917		
	600	30	2.38	4376	88	1.90	3501	1.59	2917	2.38	4376		
	300	15	1.38	4949	85	1.10	3959	0.92	3299	1.38	4949		
	100	5	0.52	5373	82	0.42	4298	0.35	3582	0.52	5373		
25	2500	100	4.05	2296	90	3.24	1837	2.70	1531	4.05	2296	2371	4000
	1750	70	3.45	2774	89	2.76	2219	2.30	1849	3.45	2774		
	1160	46	2.91	3479	88	2.33	2783	1.94	2319	2.91	3479		
	870	35	2.46	3889	87	1.97	3111	1.64	2593	2.46	3889		
	600	24	1.91	4314	86	1.53	3451	1.27	2876	1.91	4314		
	300	12	1.10	4841	83	0.88	3873	0.73	3227	1.10	4841		
	100	4	0.41	5227	80	0.33	4182	0.27	3485	0.41	5227		

1. Exact ratio
 2. If input speed is below 1160 RPM, please specify speed and mounting position to ensure proper lubrication.
 3. Overhung load is based on maximum bore size. Use of smaller driven shaft diameter may limit OHL capacity.
 4. Overhung loads are based on the output shaft and output bearing capacities only. Check overhung load section for other considerations.

5. Overhung load and thrust load ratings are computed independent of each other. For combined load applications contact Winsmith.
 Mechanical ratings shaded above exceed speed reducer thermal limitations under continuous duty conditions. See the thermal limit columns above for continuous duty thermal ratings.

Modified



DRYWELL SINGLE REDUCTION

With Mobil Glygoyle 460 Lubricant



3.500 CENTER DISTANCE			HORSEPOWER AND TORQUE RATINGS								HOLLOW OUTPUT SHAFT OVERHUNG LOAD CAPACITIES (lb) ^{3,4,5}	HOLLOW OUTPUT SHAFT THRUST LOAD CAPACITIES (lb) ⁵	
RATIO ¹	INPUT RPM ²	OUTPUT RPM	MECHANICAL						THERMAL				
			1.00 SERVICE FACTOR			1.25 SERVICE FACTOR		1.50 SERVICE FACTOR	1.00 SERVICE FACTOR				
			INPUT HP	OUTPUT TORQUE (lbf-in.)	EFF	INPUT HP	OUTPUT TORQUE (lbf-in.)	INPUT HP	OUTPUT TORQUE (lbf-in.)	INPUT HP	OUTPUT TORQUE (lbf-in.)		
30	2500	83	3.48	2297	87	2.78	1838	2.32	1531	3.48	2297	2528	4000
	1750	58	3.01	2816	87	2.41	2253	2.01	1877	3.01	2816		
	1160	39	2.54	3528	85	2.03	2822	1.69	2352	2.54	3528		
	870	29	2.20	4013	84	1.76	3210	1.47	2675	2.20	4013		
	600	20	1.74	4524	83	1.39	3619	1.16	3016	1.74	4524		
	300	10	1.03	5168	80	0.82	4134	0.69	3445	1.03	5168		
	100	3	0.40	5648	76	0.32	4518	0.27	3765	0.40	5648		
40	2500	63	2.67	2283	85	2.14	1826	1.78	1522	2.67	2283	2784	4000
	1750	44	2.27	2741	84	1.82	2193	1.51	1827	2.27	2741		
	1160	29	1.94	3479	83	1.55	2783	1.29	2319	1.94	3479		
	870	22	1.66	3912	81	1.33	3130	1.11	2608	1.66	3912		
	600	15	1.30	4363	80	1.04	3490	0.87	2909	1.30	4363		
	300	8	0.77	4925	77	0.62	3940	0.51	3283	0.77	4925		
	100	3	0.29	5339	73	0.23	4271	0.19	3559	0.29	5339		
50	2500	50	2.14	2217	82	1.71	1774	1.43	1478	2.14	2217	3025	4000
	1750	35	1.83	2681	82	1.46	2145	1.22	1787	1.83	2681		
	1160	23	1.54	3354	80	1.23	2683	1.03	2236	1.54	3354		
	870	17	1.31	3744	79	1.05	2995	0.87	2496	1.31	3744		
	600	12	1.02	4148	77	0.82	3318	0.68	2765	1.02	4148		
	300	6	0.60	4649	74	0.48	3719	0.40	3099	0.60	4649		
	100	2	0.23	5015	70	0.18	4012	0.15	3343	0.23	5015		
60	2500	42	1.74	2103	80	1.39	1682	1.16	1402	1.74	2103	3186	4000
	1750	29	1.49	2552	79	1.19	2042	0.99	1701	1.49	2552		
	1160	19	1.25	3162	78	1.00	2530	0.83	2108	1.25	3162		
	870	15	1.06	3513	77	0.85	2810	0.71	2342	1.06	3513		
	600	10	0.82	3874	75	0.66	3099	0.55	2583	0.82	3874		
	300	5	0.48	4320	72	0.38	3456	0.32	2880	0.48	4320		
	100	2	0.18	4645	68	0.14	3716	0.12	3097	0.18	4645		
80	2500	31	1.16	1738	75	0.93	1390	0.77	1159	1.16	1738	3357	4000
	1750	22	0.99	2115	74	0.79	1692	0.66	1410	0.99	2115		
	1160	15	0.81	2588	73	0.65	2070	0.54	1725	0.81	2588		
	870	11	0.68	2858	72	0.54	2286	0.45	1905	0.68	2858		
	600	8	0.53	3135	71	0.42	2508	0.35	2090	0.53	3135		
	300	4	0.30	3474	68	0.24	2779	0.20	2316	0.30	3474		
	100	1	0.11	3720	64	0.09	2976	0.07	2480	0.11	3720		
100	2500	25	0.79	1367	69	0.63	1094	0.53	911	0.79	1367	3357	4000
	1750	18	0.67	1665	69	0.54	1332	0.45	1110	0.67	1665		
	1160	12	0.54	2022	69	0.43	1618	0.36	1348	0.54	2022		
	870	9	0.45	2224	68	0.36	1779	0.30	1483	0.45	2224		
	600	6	0.35	2431	67	0.28	1945	0.23	1621	0.35	2431		
	300	3	0.20	2684	64	0.16	2147	0.13	1789	0.20	2684		
	100	1	0.07	2867	61	0.06	2294	0.05	1911	0.07	2867		

- Exact ratio
- If input speed is below 1160 RPM, please specify speed and mounting position to ensure proper lubrication.
- Overhung load is based on maximum bore size. Use of smaller driven shaft diameter may limit OHL capacity.
- Overhung loads are based on the output shaft and output bearing capacities only. Check overhung load section for other considerations.
- Overhung load and thrust load ratings are computed independent of each other. For combined load applications contact Winsmith.
 - Mechanical ratings shaded above exceed speed reducer thermal limitations under continuous duty conditions. See the thermal limit columns above for continuous duty thermal ratings.

Modified



2D DRAWINGS & 3D MODELS
www.WINSMITH.com



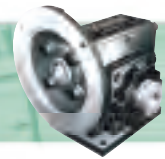

3.500 CENTER DISTANCE			HORSEPOWER AND TORQUE RATINGS								HOLLOW OUTPUT SHAFT OVERHUNG LOAD CAPACITIES (lb) ^{3,4,5}	HOLLOW OUTPUT SHAFT THRUST LOAD CAPACITIES (lb) ⁵	
RATIO ¹	INPUT RPM ²	OUTPUT RPM	MECHANICAL						THERMAL				
			1.00 SERVICE FACTOR			1.25 SERVICE FACTOR		1.50 SERVICE FACTOR	1.00 SERVICE FACTOR				
			INPUT HP	OUTPUT TORQUE (lb•in.)	EFF	INPUT HP	OUTPUT TORQUE (lb•in.)	INPUT HP	OUTPUT TORQUE (lb•in.)	INPUT HP	OUTPUT TORQUE (lb•in.)		
5	2500	500	20.91	2556	97	16.73	2045	13.94	1704	18.92	2311	2320	3955
	1750	350	17.99	3133	97	14.39	2506	11.99	2089	17.69	3081		
	1160	232	15.16	3963	96	12.13	3170	10.11	2642	15.16	3963		
	870	174	13.35	4635	96	10.68	3708	8.90	3090	13.35	4635		
	600	120	11.19	5594	95	8.95	4475	7.46	3729	11.19	5594		
	300	60	6.99	6894	94	5.59	5515	4.66	4596	6.99	6894		
	100	20	2.74	7924	92	2.19	6339	1.83	5283	2.74	7924		
7.5	2500	333	16.08	2920	96	12.86	2336	10.72	1947	14.48	2628	2660	4500
	1750	233	13.85	3580	96	11.08	2864	9.23	2387	13.51	3493		
	1160	155	11.34	4392	95	9.07	3514	7.56	2928	11.34	4392		
	870	116	10.31	5300	95	8.25	4240	6.87	3533	10.31	5300		
	600	80	8.54	6312	94	6.83	5050	5.69	4208	8.54	6312		
	300	40	5.28	7665	92	4.22	6132	3.52	5110	5.28	7665		
	100	13	2.06	8725	90	1.65	6980	1.37	5817	2.06	8725		
10	2500	250	13.12	3146	95	10.50	2517	8.75	2097	11.67	2795	2930	4500
	1750	175	11.31	3857	95	9.05	3086	7.54	2571	10.89	3712		
	1160	116	9.33	4761	94	7.46	3809	6.22	3174	9.33	4761		
	870	87	8.44	5707	93	6.75	4566	5.63	3805	8.44	5707		
	600	60	6.96	6756	92	5.57	5405	4.64	4504	6.96	6756		
	300	30	4.29	8150	90	3.43	6520	2.86	5433	4.29	8150		
	100	10	1.67	9235	88	1.34	7388	1.11	6157	1.67	9235		
15	2500	167	9.62	3391	93	7.70	2713	6.41	2261	8.39	2951	3340	4500
	1750	117	8.31	4157	93	6.65	3326	5.54	2771	7.84	3923		
	1160	77	6.90	5151	92	5.52	4121	4.60	3434	6.90	5151		
	870	58	6.23	6144	91	4.98	4915	4.15	4096	6.23	6144		
	600	40	5.13	7242	90	4.10	5794	3.42	4828	5.13	7242		
	300	20	3.17	8692	87	2.54	6954	2.11	5795	3.17	8692		
	100	7	1.24	9816	84	0.99	7853	0.83	6544	1.24	9816		
20	2500	125	7.56	3500	92	6.05	2800	5.04	2333	6.99	3228	3660	4500
	1750	88	6.54	4290	91	5.23	3432	4.36	2860	6.53	4283		
	1160	58	5.49	5365	90	4.39	4292	3.66	3577	5.49	5365		
	870	44	4.89	6307	89	3.91	5046	3.26	4205	4.89	6307		
	600	30	3.98	7332	88	3.18	5866	2.65	4888	3.98	7332		
	300	15	2.43	8668	85	1.94	6934	1.62	5779	2.43	8668		
	100	5	0.95	9691	81	0.76	7753	0.63	6461	0.95	9691		
25	2500	100	6.18	3485	90	4.94	2788	4.12	2323	5.40	3034	3950	4500
	1750	70	5.35	4272	89	4.28	3418	3.57	2848	5.08	4052		
	1160	46	4.46	5287	87	3.57	4230	2.97	3525	4.46	5287		
	870	35	4.05	6318	86	3.24	5054	2.70	4212	4.05	6318		
	600	24	3.36	7457	84	2.69	5966	2.24	4971	3.36	7457		
	300	12	2.10	8965	81	1.68	7172	1.40	5977	2.10	8965		
	100	4	0.84	10136	77	0.67	8109	0.56	6757	0.84	10136		

1. Exact ratio
 2. If input speed is below 1160 RPM, please specify speed and mounting position to ensure proper lubrication.
 3. Overhung load is based on maximum bore size. Use of smaller driven shaft diameter may limit OHL capacity.
 4. Overhung loads are based on the output shaft and output bearing capacities only. Check overhung load section for other considerations.

5. Overhung load and thrust load ratings are computed independent of each other. For combined load applications contact Winsmith.
 Mechanical ratings shaded above exceed speed reducer thermal limitations under continuous duty conditions. See the thermal limit columns above for continuous duty thermal ratings.

Modified



DRYWELL SINGLE REDUCTION

With Mobil Glygoyle 460 Lubricant



3.500 CENTER DISTANCE			HORSEPOWER AND TORQUE RATINGS									HOLLOW OUTPUT SHAFT OVERHUNG LOAD CAPACITIES (lb) ^{3,4,5}	HOLLOW OUTPUT SHAFT THRUST LOAD CAPACITIES (lb) ⁵
RATIO ¹	INPUT RPM ²	OUTPUT RPM	MECHANICAL						THERMAL				
			1.00 SERVICE FACTOR			1.25 SERVICE FACTOR		1.50 SERVICE FACTOR	1.00 SERVICE FACTOR				
			INPUT HP	OUTPUT TORQUE (lbf-in.)	EFF	INPUT HP	OUTPUT TORQUE (lbf-in.)	INPUT HP	OUTPUT TORQUE (lbf-in.)	INPUT HP	OUTPUT TORQUE (lbf-in.)		
30	2500	83	5.27	3504	88	4.22	2803	3.51	2336	4.74	3144	4260	4500
	1750	58	4.57	4295	87	3.66	3436	3.05	2863	4.47	4201		
	1160	39	3.83	5334	86	3.06	4267	2.55	3556	3.83	5334		
	870	29	3.47	6344	84	2.78	5075	2.31	4229	3.47	6344		
	600	20	2.87	7457	83	2.30	5966	1.91	4971	2.87	7457		
	300	10	1.79	8922	79	1.43	7138	1.19	5948	1.79	8922		
	100	3	0.71	10057	75	0.57	8046	0.47	6705	0.71	10057		
40	2500	63	4.06	3499	86	3.25	2799	2.71	2333	3.99	3439	4578	4500
	1750	44	3.53	4289	84	2.82	3431	2.35	2859	3.53	4289		
	1160	29	2.98	5368	83	2.38	4294	1.99	3579	2.98	5368		
	870	22	2.67	6299	81	2.14	5039	1.78	4199	2.67	6299		
	600	15	2.19	7310	80	1.75	5848	1.46	4873	2.19	7310		
	300	8	1.35	8625	76	1.08	6900	0.90	5750	1.35	8625		
	100	3	0.53	9631	72	0.42	7705	0.35	6421	0.53	9631		
50	2500	50	3.26	3410	83	2.61	2728	2.17	2273	3.26	3410	4915	4500
	1750	35	2.83	4180	82	2.26	3344	1.89	2787	2.83	4180		
	1160	23	2.41	5246	80	1.93	4197	1.61	3497	2.41	5246		
	870	17	2.14	6105	79	1.71	4884	1.43	4070	2.14	6105		
	600	12	1.74	7030	77	1.39	5624	1.16	4687	1.74	7030		
	300	6	1.07	8223	73	0.86	6578	0.71	5482	1.07	8223		
	100	2	0.41	8906	69	0.33	7125	0.27	5937	0.41	8906		
60	2500	42	2.65	3243	81	2.12	2594	1.77	2162	2.65	3243	5210	4500
	1750	29	2.31	3976	80	1.85	3181	1.54	2651	2.31	3976		
	1160	19	1.96	4994	78	1.57	3995	1.31	3329	1.96	4994		
	870	15	1.74	5779	77	1.39	4623	1.16	3853	1.74	5779		
	600	10	1.41	6620	75	1.13	5296	0.94	4413	1.41	6620		
	300	5	0.86	7699	71	0.69	6159	0.57	5133	0.86	7699		
	100	2	0.32	7993	67	0.26	6394	0.21	5329	0.32	7993		
80	2500	31	1.76	2691	76	1.41	2153	1.17	1794	1.76	2691	5231	4500
	1750	22	1.52	3299	75	1.22	2639	1.01	2199	1.52	3299		
	1160	15	1.30	4144	74	1.04	3315	0.87	2763	1.30	4144		
	870	11	1.14	4760	72	0.91	3808	0.76	3173	1.14	4760		
	600	8	0.92	5417	70	0.74	4334	0.61	3611	0.92	5417		
	300	4	0.56	6254	67	0.45	5003	0.37	4169	0.56	6254		
	100	1	0.21	6560	63	0.17	5248	0.14	4373	0.21	6560		
100	2500	25	1.19	2122	71	0.95	1698	0.79	1415	1.19	2122	5231	4500
	1750	18	1.02	2601	71	0.82	2081	0.68	1734	1.02	2601		
	1160	12	0.87	3264	69	0.70	2611	0.58	2176	0.87	3264		
	870	9	0.76	3734	68	0.61	2987	0.51	2489	0.76	3734		
	600	6	0.61	4232	67	0.49	3386	0.41	2821	0.61	4232		
	300	3	0.37	4864	63	0.30	3891	0.25	3243	0.37	4864		
	100	1	0.14	5337	60	0.11	4270	0.09	3558	0.14	5337		

1. Exact ratio
 2. If input speed is below 1160 RPM, please specify speed and mounting position to ensure proper lubrication.
 3. Overhung load is based on maximum bore size. Use of smaller driven shaft diameter may limit OHL capacity.
 4. Overhung loads are based on the output shaft and output bearing capacities only. Check overhung load section for other considerations.

5. Overhung load and thrust load ratings are computed independent of each other. For combined load applications contact Winsmith.
 Mechanical ratings shaded above exceed speed reducer thermal limitations under continuous duty conditions. See the thermal limit columns above for continuous duty thermal ratings.

Modified



2D DRAWINGS & 3D MODELS
www.WINSMITH.com



SE Maximizer Series

SE Maximizer worm gear speed reducers deliver two advanced levels of protection over and above the standard SE Encore. The SE Maximizer Plus is designed for wash down environments featuring our white Winguard Epoxy Coating System and stainless output shaft. The premium level SE Maximizer Stainless Steel reducer is designed for severe environments where no rust is tolerated. Both SE Maximizer designs ensure long, contaminate free performance with minimal maintenance. All are factory filled with Mobil Glygoyle 460 food grade synthetic (PAG) lubricant.

INDUSTRIES SERVED

- Food Processing and Handling
- Beef
- Poultry Meat and Eggs
- Pork
- Seafood
- Produce and Vegetables
- Baking
- Cereal and Grains
- Snack Food
- Beverage
- Pharmaceutical
- Chemical Processing
- Petroleum Processing
- Carwash
- Mixer Drives
- Pump Drives

SE MAXIMIZER PLUS – WASH DOWN

The SE Maximizer Plus product line incorporates a stainless steel output shaft, stainless steel fasteners and plugs, food duty white Winguard Epoxy Coating System, plastic plugs for threaded holes and a Forsheda V-Ring® on solid output shaft reducers. All of these features combined with the already uncompromising and durable SE Encore worm design provide outstanding performance and value in corrosive and wash down environments. The SE Maximizer Plus worm gear speed reducer is offered as an upgrade to the entire SE Encore product range from 1.33 inch to 4.25 inch center distances. This includes all standard single and double reduction ratios, all kits and modifications including the stand-alone helical and worm ratio multipliers. The WINSHELD exclusionary barrier seal is also available on select sizes of the SE Maximizer Plus.



SE MAXIMIZER STAINLESS STEEL

The SE Maximizer Stainless Steel product line is designed with 316 stainless steel covers and housings that are contoured and self-draining, facilitating easy wash down and preventing bacteria entrapment. The patented WINSHELD exclusionary barrier seal provides five separate barriers ensuring that the lubricant stays in and contaminants stay out. Designed to withstand the harshest wash down, chemical and food processing environments, the clean design of the SE Maximizer Stainless Steel speed reducer eliminates the possibility of reducer contamination. The SE Maximizer Stainless Steel reducer complies with all USDA and NSF standards. They are available in three center distances (sizes) with all standard ratios and product configurations including stand-alone helical gear ratio multiplier which expands torque and ratio capabilities.

Forsheda V-Ring® is a registered trademark of Trelleborg AB



Motion Control “S-Eliminator”

Very Low Backlash Worm Gear Speed Reducers with Easy Adjustment

The patented low backlash S-Eliminator is adjusted to a maximum of 2 arc-minutes backlash at assembly. A pre-loaded bearing cartridge located on the outside of the housing holds a variable lead worm in mesh with a precision gear and allows for convenient backlash adjustment without taking the unit out of service. The backlash is adjusted by loosening a locking collar and rotating the cartridge. Backlash levels in the range of arc-seconds are achievable with proper run-in. Due to the “wear-in” characteristics of worm gears, this level of fine adjustment must be made after the unit has been in service.

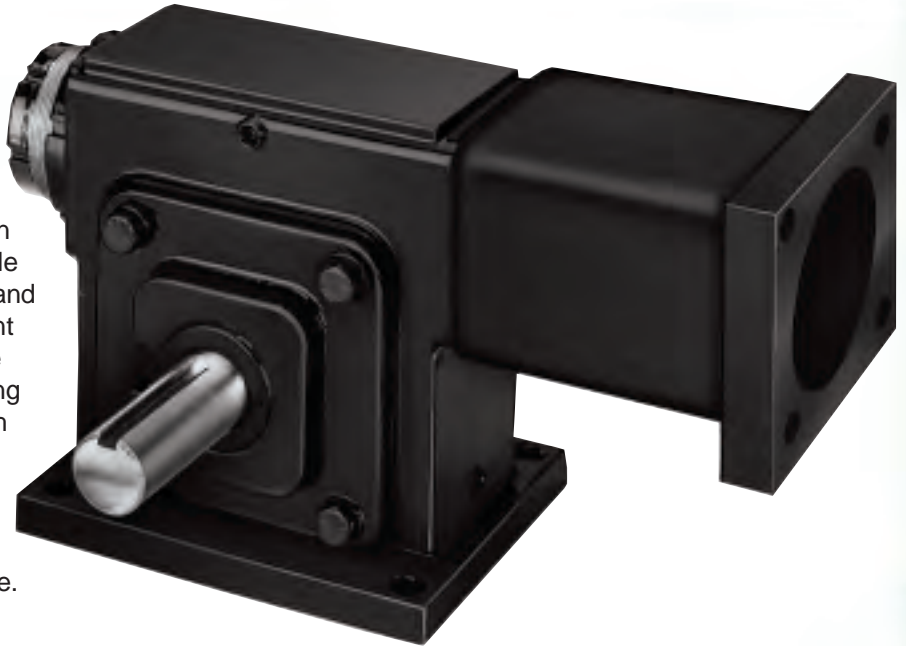

APPLICATIONS

- Machine tools
- Tension control
- Indexing operations
- Rotary tables
- Converting equipment
- Servo positioning
- Robotic positioning
- Medical machines
- Antenna positioning

STANDARD CENTER DISTANCES

- 1.33” – 3.5”

RATIO RANGE

- Single Reduction — 4:1 – 60:1

AVAILABLE MODELS

- NEMA C-Face Input adaptors
- Servo motor Input adaptors
- Non-motorized (single reduction only)

BACKLASH SPECIFICATIONS

- Factory adjusted for a maximum of 2 arc-minutes movement.

OUTPUT TORQUE

- 149 - 2450 lbf-in, depending on the center distance and the reduction.

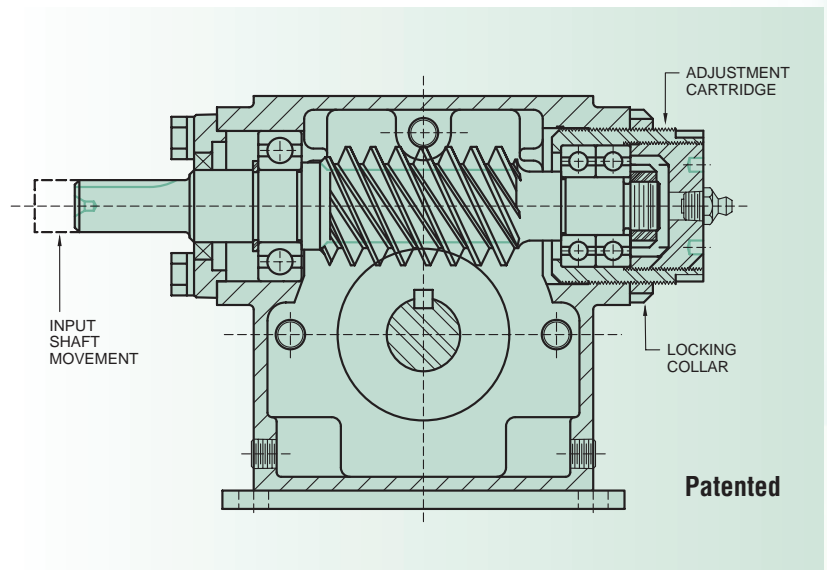

For this and other low backlash Motion Control Products, please visit www.WINSMITH.com and download the WINSMITH MOTION CONTROL CATALOG.



2D DRAWINGS & 3D MODELS
www.WINSMITH.com



Hydraulic Motor Input Adaptor Rings

SE Encore products accommodate hydraulic motors by using an adaptor ring that interfaces with an SAE 2 or SAE 4 bolt motor mounting flange, a coupled input speed reducer (e.g. CDSS), and a customer supplied coupling.

The hydraulic motor adaptor ring has two threaded bolt patterns, one that match's the required SAE flange pattern and a second bolt pattern that mates to the reducer input adaptor. Coupled input reducer dimensions can be found in the Integral Products Section (page 30).

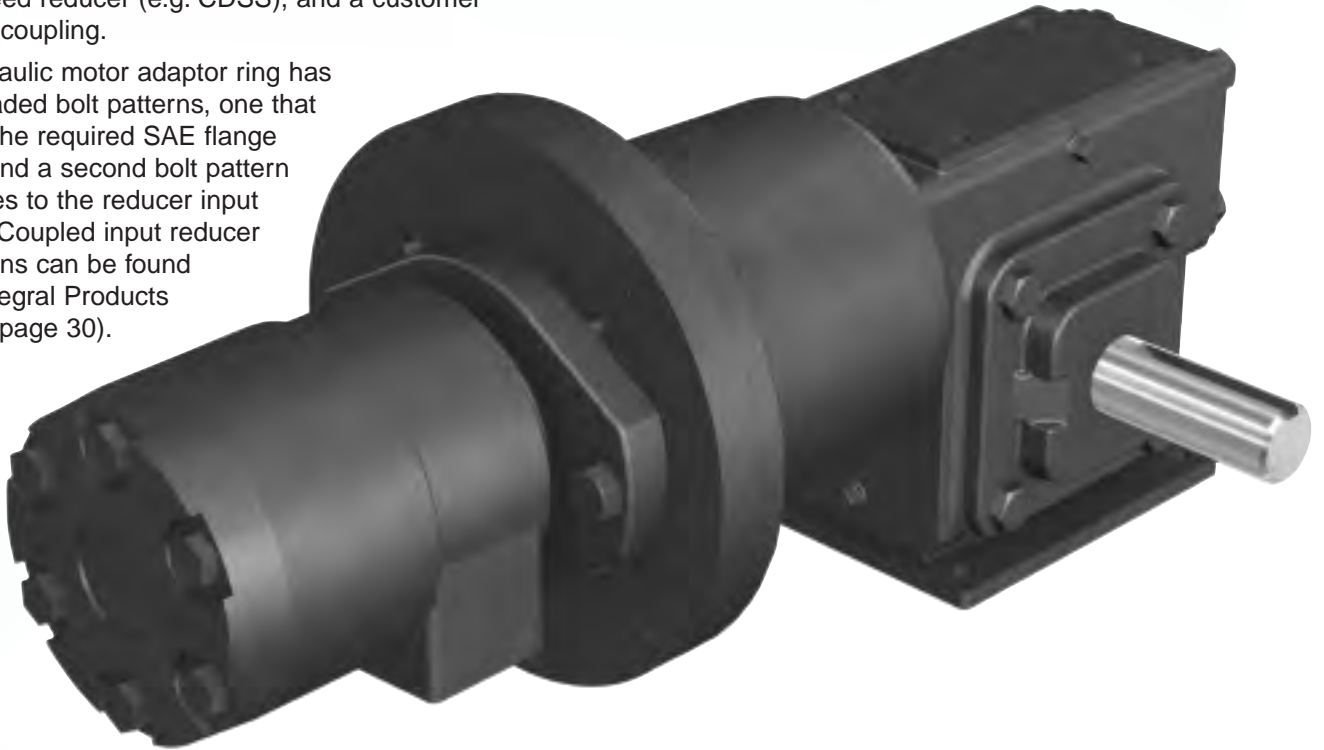

EXPLODED VIEW

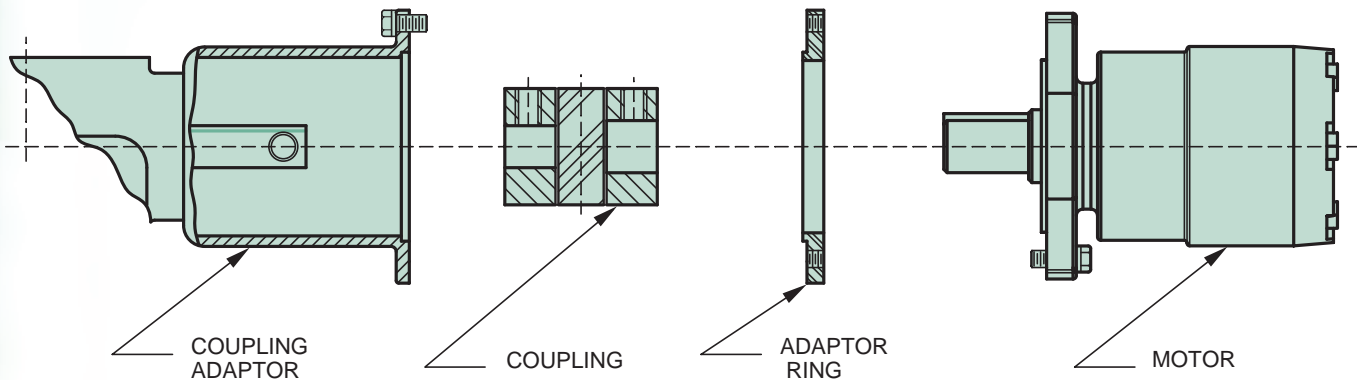

Modified

Coupled Input Adaptor/Adaptor Ring Dimensions

DIMENSIONS

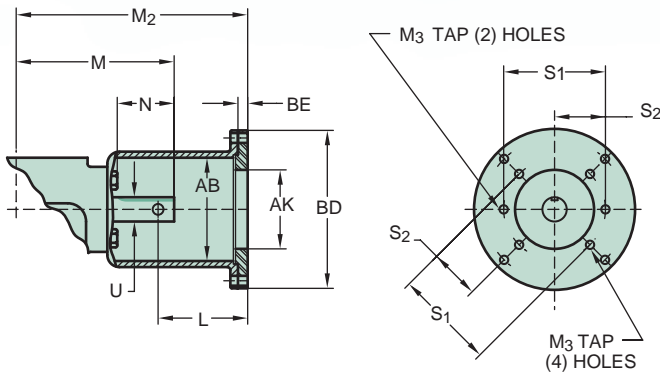

FIGURE 1
82-2, 82-4 / SAE A 2 & 4 BOLT
MOTOR MOUNTING

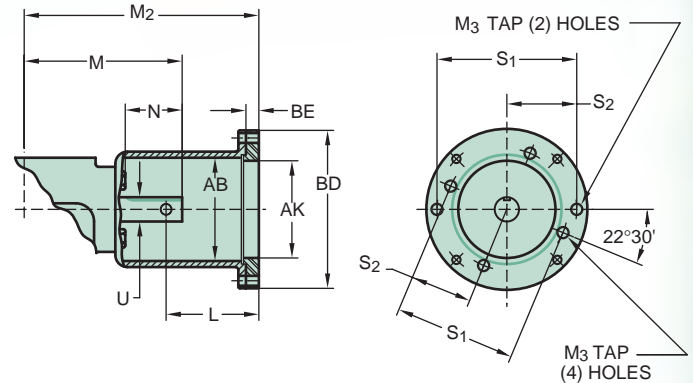

FIGURE 2
101-2, 101-4 / SAE B 2 & 4 BOLT
MOTOR MOUNTING

(NOTE: 101-4 / SAE B 4 BOLT MOTOR MOUNTS @ 22.5° ANGLE
CONTACT FACTORY IF MOTOR FLANGE THICKNESS IS NOT
BETWEEN .51-.57" TO INSURE PROPER BOLT ENGAGEMENT)

UNIT SIZE	FLANGE		FIG.	AB	AK	BE	BD	M	M ₂	N	L SET SCREW ACCESS	S ₁	S ₂	M ₃ TAP & DEPTH	U	KEYWAY	RECOMMENDED COUPLING		
	SAE	ISO/NFPA															LL SHAFT*	LS SHAFT	
E17	A 2-Bolt	82-2	1	3.75	3.25	.40	6.63	4.75	7.90	1.25	3.65	4.188	2.094	.375-16 x .40	.750	3/16 x 3/32	L 100	L 100	
	A 4-Bolt	82-4	1		3.25	.40						4.125	2.063						
	B 2-Bolt	101-2	2		4.00	.59			5.750			2.875	.500-13 x .53				L 099		
	B 4-Bolt	101-4	2		4.00	.59													5.000
E20	A 2-Bolt	82-2	1	3.75	3.25	.40	6.63	5.00	7.90	1.50	3.65	4.188		2.094	.375-16 x .40	.750	3/16 x 3/32	L 100	L 100
	A 4-Bolt	82-4	1		3.25	.40						4.125		2.063					
	B 2-Bolt	101-2	2		4.00	.59			5.750			2.875	.500-13 x .53	L 099*					
	B 4-Bolt	101-4	2		4.00	.59												5.000	
E24	A 2-Bolt	82-2	1	4.13	3.25	.40	6.63	6.50	9.53	2.00	3.78	4.188		2.094	.375-16 x .40	1.00	1/4 x 1/8	L 100*	L 100
	A 4-Bolt	82-4	1		3.25	.40						4.125		2.063					
	B 2-Bolt	101-2	2		4.00	.59		5.750	2.875			.500-13 x .53	L 110						
	B 4-Bolt	101-4	2		4.00	.59								5.000				2.500	
E26	A 2-Bolt	82-2	1	4.13	3.25	.40	6.63	6.50	9.53	2.00	3.78		4.188	2.094	.375-16 x .40	1.00	1/4 x 1/8	L 100*	L 100
	A 4-Bolt	82-4	1		3.25	.40							4.125	2.063					
	B 2-Bolt	101-2	2		4.00	.59		5.750	2.875			.500-13 x .53	L 110						
	B 4-Bolt	101-4	2		4.00	.59								5.000				2.500	
E30	A 2-Bolt	82-2	1	4.13	3.25	.40	6.63	7.00	10.15	2.13	3.90		4.188	2.094	.375-16 x .40	1.00	1/4 x 1/8	L 100	L 100
	A 4-Bolt	82-4	1		3.25	.40							4.125	2.063					
	B 2-Bolt	101-2	2		4.00	.59		5.750	2.875			.500-13 x .53	L 110						
	B 4-Bolt	101-4	2		4.00	.59								4.09				5.000	
E35	A 2-Bolt	82-2	1	4.13	3.25	.40	6.63	7.38	10.40	2.25	3.90		4.188	2.094	.375-16 x .40	1.00	1/4 x 1/8	L 100*	L 110
	A 4-Bolt	82-4	1		3.25	.40							4.125	2.063					
	B 2-Bolt	101-2	2		4.00	.59		5.750	2.875			.500-13 x .53	L 110						
	B 4-Bolt	101-4	2		4.00	.59								4.09				5.000	
E43	A 2-Bolt	82-2	1	4.13	3.25	.40	6.63	8.19	11.21	2.25	3.90		4.188	2.094	.375-16 x .40	1.25	1/4 x 1/8	CJ 38/45	L 110
	A 4-Bolt	82-4	1		3.25	.40							4.125	2.063					
	B 2-Bolt	101-2	2		4.00	.59		5.750	2.875			.500-13 x .53	L 110						
	B 4-Bolt	101-4	2		4.00	.59								4.09				5.000	

* Only available in shaft id code 22-1; 25-1 has interference with worm shaft.

▲ Winsmith recommends use of optional long length (LL) shaft due to longer length of engagement.

■ Use open spider on coupling.



2D DRAWINGS & 3D MODELS
www.WINSMITH.com



Coupled Input Adaptor/Adaptor Ring Dimensions

DIMENSIONS AND IDENTIFICATION CODE FOR MOUNTING FLANGES AND SHAFT ENDS IN ACCORDANCE WITH SAE J744-1996 AND ISO 3019-1:2001*

SAE 2-BOLT MOUNTING FLANGES

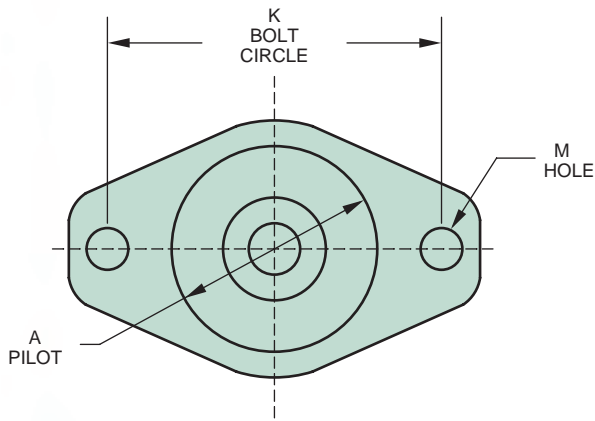

2-Bolt Mounting Flange Data

MOUNTING FLANGE		PILOT DIMENSIONS	FLANGE DIMENSIONS	
ISO/NFPA	SAE	A	K	M
82-2	A	3.250 - 3.248	4.188	.438
101-2	B	4.000 - 3.998	5.750	.562

SAE 4-BOLT MOUNTING FLANGES

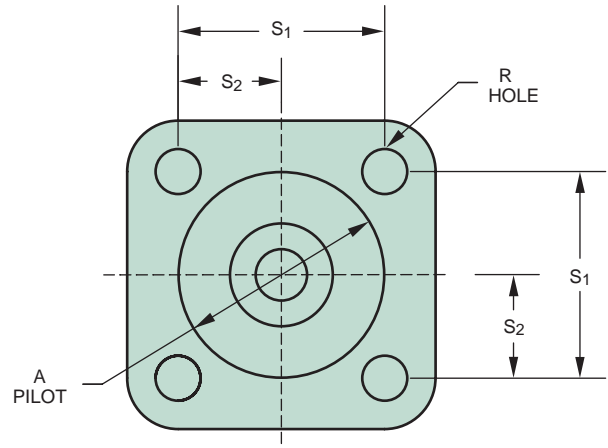

4-Bolt Mounting Flange Data

MOUNTING FLANGE		PILOT DIMENSIONS	FLANGE DIMENSIONS		
ISO/NFPA	SAE	A	S ₁	S ₂	R
	A	3.250 - 3.248	2.917	1.458	.438
101-4	B	4.000 - 3.998	3.536	1.768	.562

STRAIGHT SHAFT

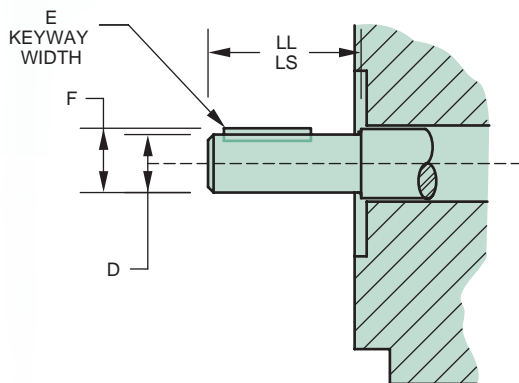

Straight Shaft Dimensions

SHAFT I.D. CODE	D	+ .001	± .005	LL	LS
		- .001	E		
16-1	.625 .624	.1563	.693	2.00	.938
19-1	.750 .749	.188	.831	2.00	.938
22-1	.875 .874	.250	.982	2.50	1.312
25-1	1.000 .998	.250	1.106	2.75	1.500

Tolerances – 2 place dimensions ± .030
3 place dimensions ± .010

Motor Adaptor Ring Kits

HYDRAULIC MOTOR FLANGE	KIT #
SAE-A 2 OR 4 BOLT	YKIT9810175
SAE-B 2 OR 4 BOLT	YKIT9810176

Flange/Shaft Combinations

FLANGE SERIES	SHAFT SERIES
82-	16-
82-	19-
101-	22-
101-	22-

* Redesignation of ANSI/(NFPA) T3.9.2 R2-1990

Ratings Summary

INPUT MOTOR HORSEPOWER AND TORQUE RATINGS (lbf-in.) AT 1750 RPM INPUT

1.00 SERVICE FACTOR*

REDUCER SIZE	RATIO ¹		4	5	7.5	10	15	20	25	30	40	50	60	80	100
	OUTPUT RPM		438	350	233	175	117	88	70	58	44	35	29	21	18
	RATINGS AT 1750 RPM INPUT ²														
E13	Page #	HP	1.10	1.39	1.05	0.86	0.62	0.42	0.41	0.35	0.27	0.17	0.15	n/a	n/a
	160-161	Torque	149	238	266	284	295	257	304	293	276	213	202	n/a	n/a
E17	Page #	HP	1.98	2.69	2.06	1.64	1.15	0.94	0.70	0.66	0.52	0.41	0.27	0.16	0.11
	162-163	Torque	269	462	525	554	568	604	547	596	603	558	417	311	236
E20	Page #	HP	3.00	3.70	2.84	2.24	1.59	1.24	1.01	0.86	0.68	0.56	0.41	0.22	0.16
	164-165	Torque	411	639	732	769	794	806	803	788	795	791	656	437	355
E24	Page #	HP	4.74	5.89	4.54	3.67	2.71	2.11	1.61	1.45	1.11	0.92	0.70	0.38	0.27
	166-167	Torque	653	1017	1168	1249	1359	1383	1285	1360	1335	1329	1134	735	576
E26	Page #	HP	6.19	7.70	5.93	4.82	3.42	2.64	2.17	1.80	1.42	1.18	0.92	0.49	0.34
	168-169	Torque	852	1334	1533	1650	1724	1745	1758	1712	1737	1748	1556	979	767
E30	Page #	HP	9.30	10.87	8.59	7.11	5.07	3.95	3.24	2.67	2.08	1.72	1.34	0.71	0.48
	170-171	Torque	1289	1886	2232	2448	2578	2645	2676	2586	2617	2643	2367	1478	1160
E35	Page #	HP	13.20	15.82	12.55	10.27	7.51	5.73	4.71	4.07	3.04	2.44	2.00	1.12	0.67
	172-173	Torque	1838	2738	3252	3515	3804	3821	3884	3943	3837	3753	3573	2403	1666
E43	Page #	HP	20.50	25.16	19.39	15.84	11.63	9.16	7.50	6.40	4.94	3.96	3.23	1.91	1.02
	174-175	Torque	2861	4382	5011	5400	5819	6007	5981	6013	6005	5852	5566	4144	2602

INPUT MOTOR HORSEPOWER AND TORQUE RATINGS (lbf-in.) AT 1160 RPM INPUT

1.00 SERVICE FACTOR*

REDUCER SIZE	RATIO ¹		4	5	7.5	10	15	20	25	30	40	50	60	80	100
	OUTPUT RPM		438	232	155	116	77	58	46	39	29	23	19	14	12
	RATINGS AT 1160 RPM INPUT ²														
E13	Page #	HP	0.92	1.06	0.78	0.65	0.48	0.30	0.31	0.27	0.18	0.13	0.11	n/a	n/a
	160-161	Torque	179	276	301	320	342	271	345	341	291	237	224	n/a	n/a
E17	Page #	HP	1.72	2.16	1.58	1.24	0.78	0.67	0.47	0.48	0.39	0.28	0.19	0.12	0.08
	162-163	Torque	337	562	610	632	571	645	554	660	676	564	435	346	257
E20	Page #	HP	2.59	2.85	2.18	1.68	1.06	0.91	0.73	0.66	0.51	0.41	0.27	0.16	0.12
	164-165	Torque	515	743	849	863	788	891	865	920	920	882	660	486	394
E24	Page #	HP	4.17	4.81	3.64	2.55	1.81	1.60	1.05	0.94	0.73	0.63	0.46	0.29	0.20
	166-167	Torque	840	1263	1431	1321	1376	1611	1280	1350	1333	1421	1138	837	654
E26	Page #	HP	5.29	5.96	4.67	3.41	2.41	1.76	1.43	1.28	1.06	0.84	0.60	0.37	0.25
	168-169	Torque	1061	1567	1836	1770	1847	1764	1762	1864	2028	1932	1562	1126	880
E30	Page #	HP	7.83	8.75	7.11	5.31	3.35	2.70	2.19	1.95	1.59	1.29	0.88	0.54	0.37
	170-171	Torque	1585	2303	2802	2768	2580	2745	2749	2891	3101	3057	2381	1735	1356
E35	Page #	HP	11.4	12.97	10.41	8.51	6.21	4.79	3.87	3.33	2.51	1.97	1.41	0.79	0.54
	172-173	Torque	2324	3395	4084	4413	4771	4868	4871	4939	4871	4695	3863	2589	2023
E43	Page #	HP	17.6	21.19	15.87	13.06	9.66	7.69	6.24	5.32	4.09	3.27	2.58	1.31	0.87
	174-175	Torque	3618	5541	6149	6666	7211	7511	7402	7467	7515	7345	6742	4189	3266

* For thermal limit ratings of 1.25 service factors and 1.50 service factors, please contact Winsmith.

1. Exact ratio

2. If input speed is below 1160 RPM, please specify speed and mounting position to ensure proper lubrication.

□ Mechanical ratings shaded above exceed speed reducer thermal limitations under continuous duty conditions. Refer to Appendix (page 229) for Continuous Duty Thermal Limit Ratings.



2D DRAWINGS & 3D MODELS
www.WINSMITH.com



Selection By Input Horsepower

REDUCER SIZE AND TORQUE (lbf·in.) AT 1750 RPM INPUT²

1.00 SERVICE FACTOR

OUTPUT RPM	RATIO ¹	HP	INPUT HORSEPOWER										
			0.25	0.33	0.50	0.75	1.00	1.50	2.00	3.00	5.00	7.50	10.00
438	4	SIZE			E13	E13	E13	E17	E17	E20	E26	E30	E35
		TORQUE			65	98	131	198	264	400	672	1017	1362
350	5	SIZE			E13	E13	E13	E17	E17	E20	E24	E26	E30
		TORQUE			86	128	171	258	343	518	863	1299	1735
233	7.5	SIZE		E13	E13	E13	E17	E17	E24	E26	E30	E35	
		TORQUE		84	127	190	253	382	510	772	1293	1949	2591
175	10	SIZE		E13	E13	E13	E17	E17	E20	E24	E30	E35	E35
		TORQUE		109	165	248	338	507	687	1021	1722	2567	3423
117	15	SIZE		E13	E13	E17	E17	E20	E24	E26	E30	E35	E43
		TORQUE		157	238	370	494	749	1003	1512	2542	3799	5003
88	20	SIZE	E13	E13	E17	E17	E20	E24	E24	E30	E35	E43	
		TORQUE	153	202	321	483	650	983	1311	2009	3334	4918	
70	25	SIZE	E13	E13	E17	E20	E20	E24	E26	E30	E43	E43	
		TORQUE	185	245	391	596	795	1197	1620	2478	3987	5981	
58	30	SIZE	E13	E13	E17	E20	E24	E26	E30	E35	E43		
		TORQUE	209	276	452	687	938	1427	1937	2906	4698		
44	40	SIZE	E13	E17	E17	E24	E24	E30	E30	E35			
		TORQUE	256	383	580	902	1203	1887	2516	3787			
35	50	SIZE	E17	E17	E20	E24	E26	E30	E35	E43			
		TORQUE	340	449	706	1083	1481	2305	3076	4433			
29	60	SIZE	E17	E20	E24	E26	E30	E35	E35	E43			
		TORQUE	386	525	810	1268	1766	2680	3573	5170			
22	80	SIZE	E24	E24	E26	E35	E35	E43					
		TORQUE	484	638	979	1609	2146	3255					
17.5	100	SIZE	E24	E26	E35	E43	E43						
		TORQUE	533	744	1243	1913	2551						

REDUCER SIZE AND TORQUE (lbf·in.) AT 1750 RPM INPUT²

1.25 SERVICE FACTOR

OUTPUT RPM	RATIO ¹	HP	INPUT HORSEPOWER										
			0.25	0.33	0.50	0.75	1.00	1.50	2.00	3.00	5.00	7.50	10.00
438	4	SIZE			E13	E13	E17	E17	E20	E24	E26	E30	E35
		TORQUE			65	98	132	198	267	404	672	1017	1362
350	5	SIZE			E13	E13	E13	E17	E17	E20	E26	E30	E35
		TORQUE			86	128	171	258	343	518	866	1301	1730
233	7.5	SIZE		E13	E13	E13	E17	E17	E20	E24	E30	E35	E35
		TORQUE		84	127	190	255	382	515	772	1299	1943	2591
175	10	SIZE		E13	E13	E17	E17	E20	E24	E26	E30	E35	E43
		TORQUE		109	165	253	338	515	680	1026	1722	2567	3410
117	15	SIZE		E13	E13	E17	E20	E24	E24	E30	E35	E43	
		TORQUE		157	238	370	500	751	1003	1524	2532	3753	
88	20	SIZE	E13	E13	E17	E17	E20	E24	E26	E30	E43		
		TORQUE	153	202	321	483	650	983	1322	2009	3279		
70	25	SIZE	E13	E13	E17	E20	E24	E26	E30	E35	E43		
		TORQUE	185	244	391	596	798	1215	1653	2472	3987		
58	30	SIZE	E13	E17	E17	E24	E24	E30	E30	E35	E43		
		TORQUE	209	298	452	703	938	1450	1937	2906	4698		
44	40	SIZE	E17	E17	E20	E24	E26	E30	E35	E43			
		TORQUE	290	383	585	902	1223	1887	2524	3647			
35	50	SIZE	E17	E17	E24	E24	E30	E35	E35	E43			
		TORQUE	340	449	722	1083	1537	2307	3076	4433			
29	60	SIZE	E20	E20	E24	E26	E30	E35	E43				
		TORQUE	400	525	810	1268	1766	2680	3446				
22	80	SIZE	E24	E26	E30	E35	E43	E43					
		TORQUE	484	659	1041	1609	2170	3255					
17.5	100	SIZE	E26	E30	E35	E43							
		TORQUE	564	798	1243	1913							

1. Exact ratio

2. If input speed is below 1160 RPM, please specify speed and mounting position to ensure proper lubrication.

☐ Mechanical ratings shaded above exceed speed reducer thermal limitations under continuous duty conditions. Refer to Appendix (page 229) for Continuous Duty Thermal Limit Ratings.

Selection By Input Horsepower

REDUCER SIZE AND TORQUE (lbf-in.) AT 1750 RPM INPUT²

1.50 SERVICE FACTOR

OUTPUT RPM	RATIO ¹	HP	INPUT HORSEPOWER										
			0.25	0.33	0.50	0.75	1.00	1.50	2.00	3.00	5.00	7.50	10.00
438	4	SIZE			E13	E13	E17	E20	E20	E24	E30	E35	E43
		TORQUE			65	98	132	200	267	404	678	1021	1375
350	5	SIZE			E13	E13	E17	E17	E20	E24	E26	E35	E35
		TORQUE			86	128	171	258	345	518	866	1298	1730
233	7.5	SIZE		E13	E13	E17	E17	E20	E24	E24	E30	E35	E43
		TORQUE		84	127	191	255	387	515	772	1299	1943	2584
175	10	SIZE		E13	E13	E17	E17	E20	E24	E26	E35	E43	E43
		TORQUE		109	165	253	338	515	680	1026	1711	2557	3410
117	15	SIZE		E13	E17	E17	E20	E24	E26	E30	E35	E43	
		TORQUE		157	247	370	500	751	1008	1524	2532	3753	
88	20	SIZE	E13	E17	E17	E20	E24	E26	E30	E35	E43		
		TORQUE	153	212	321	488	655	991	1339	2001	3279		
70	25	SIZE	E13	E17	E20	E24	E24	E26	E30	E35	E43		
		TORQUE	185	258	398	599	798	1215	1653	2472	3987		
58	30	SIZE	E17	E17	E20	E24	E24	E30	E35	E43			
		TORQUE	226	298	458	703	938	1450	1938	2819			
44	40	SIZE	E17	E17	E24	E24	E26	E35	E35	E43			
		TORQUE	290	383	601	902	1223	1893	2524	3647			
35	50	SIZE	E17	E20	E24	E26	E30	E35	E43				
		TORQUE	340	466	722	1111	1537	2307	2956				
29	60	SIZE	E20	E24	E26	E30	E35	E43	E43				
		TORQUE	400	535	846	1325	1787	2585	3446				
22	80	SIZE	E24	E26	E35	E35	E43						
		TORQUE	484	659	1073	1609	2170						
17.5	100	SIZE	E30	E35	E43								
		TORQUE	604	821	1275								

1. Exact ratio

2. If input speed is below 1160 RPM, please specify speed and mounting position to ensure proper lubrication.

MODEL	QUILL INPUT ADAPTOR SIZES	COUPLED INPUT ADAPTOR SIZES
E13	42C, 48C, 56C, 140TC	42C, 48C, 56C, 140TC
E17	42C, 48C, 56C, 140TC	42C, 48C, 56C, 140TC, 180TC
E20	42C, 48C, 56C, 140TC	42C, 48C, 56C, 140TC, 180TC
E24	56C, 140TC, 180TC	56C, 140TC, 180TC
E26	56C, 140TC, 180TC	56C, 140TC, 180TC
E30	56C, 140TC, 180TC	56C, 140TC, 180TC, 210TC
E35	56C, 140TC, 180TC	56C, 140TC, 180TC, 210TC
E43	56C, 140TC, 180TC, 210TC	56C, 140TC, 180TC, 210TC

Ratings



2D DRAWINGS & 3D MODELS
www.WINSMITH.com



SINGLE REDUCTION
With Mobil Glycoyle 460 Lubricant



1.333 CENTER DISTANCE			HORSEPOWER AND TORQUE RATINGS							OVERHUNG LOAD CAPACITIES (lb)			THRUST LOAD CAPACITIES (lb)	
RATIO ¹	INPUT RPM ²	OUTPUT RPM	MECHANICAL							INPUT SHAFT ALL SHAFT INPUT MODELS	OUTPUT SHAFT ^{4,5}		OUTPUT SHAFT ⁵	
			1.00 SERVICE FACTOR			1.25 SERVICE FACTOR		1.50 SERVICE FACTOR			SOLID ³ SHAFT (e.g. MDNS)	HOLLOW SHAFT (e.g. MDSS)	SOLID SHAFT (e.g. MDNS)	HOLLOW SHAFT (e.g. MDSS)
			INPUT HP	OUTPUT TORQUE (lb•in.)	EFF	INPUT HP	OUTPUT TORQUE (lb•in.)	INPUT HP	OUTPUT TORQUE (lb•in.)					
4	SEE MODIFIED PRODUCT SECTION													
5	2500	500	1.68	197	93	1.34	158	1.12	131	136	290	580		
	1750	350	1.39	238	95	1.11	190	0.93	159					
	1160	232	1.06	276	96	0.85	221	0.71	184					
	870	174	0.87	297	95	0.70	238	0.58	198					
	600	120	0.64	319	95	0.51	255	0.43	213					
	300	60	0.34	344	96	0.27	275	0.23	229					
	100	20	0.11	320	94	0.09	256	0.07	213					
7.5	2500	333	1.32	227	91	1.06	182	0.88	151	132	290	624		
	1750	233	1.05	266	93	0.84	213	0.70	177					
	1160	155	0.78	301	94	0.62	241	0.52	201					
	870	116	0.63	319	93	0.50	255	0.42	213					
	600	80	0.46	338	94	0.37	270	0.31	225					
	300	40	0.24	360	95	0.19	288	0.16	240					
	100	13	0.08	345	93	0.06	276	0.05	230					
10	2500	250	1.08	244	89	0.86	195	0.72	163	125	290	624		
	1750	175	0.86	284	91	0.69	227	0.57	189					
	1160	116	0.65	320	91	0.52	256	0.43	213					
	870	87	0.51	339	92	0.41	271	0.34	226					
	600	60	0.37	358	93	0.30	286	0.25	239					
	300	30	0.20	381	92	0.16	305	0.13	254					
	100	10	0.07	379	90	0.06	303	0.05	253					
15	2500	167	0.80	258	86	0.64	206	0.53	172	100	290	624		
	1750	117	0.62	295	88	0.50	236	0.41	197					
	1160	77	0.48	342	87	0.38	274	0.32	228					
	870	58	0.38	362	89	0.30	290	0.25	241					
	600	40	0.27	381	90	0.22	305	0.18	254					
	300	20	0.14	390	88	0.11	312	0.09	260					
	100	7	0.05	389	86	0.04	311	0.03	259					
20	2500	125	0.58	242	83	0.46	194	0.39	161	100	290	624		
	1750	88	0.42	257	85	0.34	206	0.28	171					
	1160	58	0.30	271	84	0.24	217	0.20	181					
	870	44	0.23	277	84	0.18	222	0.15	185					
	600	30	0.16	281	84	0.13	225	0.11	187					
	300	15	0.08	290	85	0.06	232	0.05	193					
	100	5	0.03	301	83	0.02	241	0.02	201					
25	2500	100	0.53	267	80	0.42	214	0.35	178	100	290	624		
	1750	70	0.41	304	82	0.33	243	0.27	203					
	1160	46	0.31	345	82	0.25	276	0.21	230					
	870	35	0.24	364	82	0.19	291	0.16	243					
	600	24	0.17	382	84	0.14	306	0.11	255					
	300	12	0.09	384	82	0.07	307	0.06	256					
	100	4	0.03	384	80	0.02	307	0.02	256					

1. Exact ratio.
 2. If input speed is below 1160 RPM, please specify speed and mounting position to ensure proper lubrication.
 3. Overhung load given at a distance equal to one shaft diameter from the face of the output seal.
 4. Overhung load is based on maximum bore size. Use of smaller driven shaft diameter may limit OHL capacity.

5. Overhung loads are based on the output shaft and output bearing capacities only. Check Overhung Load Section for other considerations.

Ratings





SINGLE REDUCTION

With Mobil Glygoyle 460 Lubricant

REDUCER SIZE

E13

1.333 CENTER DISTANCE			HORSEPOWER AND TORQUE RATINGS							OVERHUNG LOAD CAPACITIES (lb)			THRUST LOAD CAPACITIES (lb)	
RATIO ¹	INPUT RPM ²	OUTPUT RPM	MECHANICAL							INPUT SHAFT	OUTPUT SHAFT ^{4,5}		OUTPUT SHAFT ⁵	
			1.00 SERVICE FACTOR			1.25 SERVICE FACTOR		1.50 SERVICE FACTOR		ALL SHAFT INPUT MODELS	SOLID ³ SHAFT (e.g. MDNS)	HOLLOW SHAFT (e.g. MDSS)	SOLID SHAFT (e.g. MDNS)	HOLLOW SHAFT (e.g. MDSS)
			INPUT HP	OUTPUT TORQUE (lbf-in.)	EFF	INPUT HP	OUTPUT TORQUE (lbf-in.)	INPUT HP	OUTPUT TORQUE (lbf-in.)					
30	2500	83	0.44	255	76	0.35	204	0.29	170	100	290	624		
	1750	58	0.35	293	78	0.28	234	0.23	195					
	1160	39	0.27	341	78	0.22	273	0.18	227					
	870	29	0.21	372	80	0.17	298	0.14	248					
	600	20	0.16	392	80	0.13	314	0.11	261					
	300	10	0.08	391	78	0.06	313	0.05	261					
	100	3	0.03	393	76	0.02	314	0.02	262					
40	2500	63	0.36	258	71	0.29	206	0.24	172	100	290	624		
	1750	44	0.27	276	72	0.22	221	0.18	184					
	1160	29	0.18	291	73	0.14	233	0.12	194					
	870	22	0.14	297	73	0.11	238	0.09	198					
	600	15	0.10	300	73	0.08	240	0.07	200					
	300	8	0.05	294	75	0.04	235	0.03	196					
	100	3	0.02	302	72	0.02	242	0.01	201					
50	2500	50	0.22	186	67	0.18	149	0.15	124	100	290	624		
	1750	35	0.17	213	68	0.14	170	0.11	142					
	1160	23	0.13	237	69	0.10	190	0.09	158					
	870	17	0.10	250	69	0.08	200	0.07	167					
	600	12	0.07	262	69	0.06	210	0.05	175					
	300	6	0.04	273	70	0.03	218	0.03	182					
	100	2	0.01	273	69	0.01	218	0.01	182					
60	2500	42	0.19	177	63	0.15	142	0.13	118	115	290	624		
	1750	29	0.15	202	64	0.12	162	0.10	135					
	1160	19	0.11	224	64	0.09	179	0.07	149					
	870	15	0.08	236	64	0.06	189	0.05	157					
	600	10	0.06	239	64	0.05	191	0.04	159					
	300	5	0.03	239	64	0.02	191	0.02	159					
	100	2	0.01	239	65	0.01	191	0.01	159					

1. Exact ratio.
 2. If input speed is below 1160 RPM, please specify speed and mounting position to ensure proper lubrication.
 3. Overhung load given at a distance equal to one shaft diameter from the face of the output seal.
 4. Overhung load is based on maximum bore size. Use of smaller driven shaft diameter may limit OHL capacity.

5. Overhung loads are based on the output shaft and output bearing capacities only. Check Overhung Load Section for other considerations.

Ratings



2D DRAWINGS & 3D MODELS
www.WINSMITH.com



SINGLE REDUCTION

With Mobil Glygoyle 460 Lubricant



1.750 CENTER DISTANCE			HORSEPOWER AND TORQUE RATINGS							OVERHUNG LOAD CAPACITIES (lb)			THRUST LOAD CAPACITIES (lb)	
RATIO ¹	INPUT RPM ²	OUTPUT RPM	MECHANICAL							INPUT SHAFT ALL SHAFT INPUT MODELS	OUTPUT SHAFT ^{5,6}		OUTPUT SHAFT ⁶	
			1.00 SERVICE FACTOR			1.25 SERVICE FACTOR		1.50 SERVICE FACTOR			SOLID ³ SHAFT (e.g. MDNS)	HOLLOW ⁴ SHAFT (e.g. MDSS)	SOLID SHAFT (e.g. MDNS)	HOLLOW SHAFT (e.g. MDSS)
INPUT HP	OUTPUT TORQUE (lb-ft-in.)	EFF	INPUT HP	OUTPUT TORQUE (lb-ft-in.)	INPUT HP	OUTPUT TORQUE (lb-ft-in.)	INPUT HP	OUTPUT TORQUE (lb-ft-in.)						
4	SEE MODIFIED PRODUCT SECTION													
5	2500	500	3.18	379	95	2.54	303	2.12	253	183	572	578	711	823
	1750	350	2.69	462	95	2.15	370	1.79	308					
	1160	232	2.16	562	96	1.73	450	1.44	375					
	870	174	1.78	619	96	1.42	495	1.19	413					
	600	120	1.34	678	97	1.07	542	0.89	452					
	300	60	0.74	749	97	0.59	599	0.49	499					
	100	20	0.27	801	94	0.22	641	0.18	534					
7.5	2500	333	2.46	435	93	1.97	348	1.64	290	205	617	626	823	952
	1750	233	2.06	525	94	1.65	420	1.37	350					
	1160	155	1.58	610	95	1.26	488	1.05	407					
	870	116	1.27	656	95	1.02	525	0.85	437					
	600	80	0.89	668	96	0.71	534	0.59	445					
	300	40	0.44	666	96	0.35	533	0.29	444					
	100	13	0.15	667	92	0.12	534	0.10	445					
10	2500	250	2.02	470	92	1.62	376	1.35	313	159	650	683	894	1052
	1750	175	1.64	554	94	1.31	443	1.09	369					
	1160	116	1.24	632	93	0.99	506	0.83	421					
	870	87	0.93	635	94	0.74	508	0.62	423					
	600	60	0.64	638	94	0.51	510	0.43	425					
	300	30	0.32	627	94	0.26	502	0.21	418					
	100	10	0.11	627	90	0.09	502	0.07	418					
15	2500	167	1.43	484	90	1.14	387	0.95	323	152	650	700	894	1310
	1750	117	1.15	568	91	0.92	454	0.77	379					
	1160	77	0.78	571	90	0.62	457	0.52	381					
	870	58	0.58	571	91	0.46	457	0.39	381					
	600	40	0.39	566	91	0.31	453	0.26	377					
	300	20	0.20	580	91	0.16	464	0.13	387					
	100	7	0.07	606	88	0.06	485	0.05	404					
20	2500	125	1.18	521	87	0.94	417	0.79	347	149	650	700	894	1440
	1750	88	0.94	604	89	0.75	483	0.63	403					
	1160	58	0.67	645	88	0.54	516	0.45	430					
	870	44	0.50	647	89	0.40	518	0.33	431					
	600	30	0.34	645	90	0.27	516	0.23	430					
	300	15	0.17	644	89	0.14	515	0.11	429					
	100	5	0.06	646	86	0.05	517	0.04	431					
25	2500	100	0.97	523	85	0.78	418	0.65	349	153	650	700	894	1440
	1750	70	0.70	547	87	0.56	438	0.47	365					
	1160	46	0.47	554	86	0.38	443	0.31	369					
	870	35	0.36	555	85	0.29	444	0.24	370					
	600	24	0.25	558	86	0.20	446	0.17	372					
	300	12	0.13	566	86	0.10	453	0.09	377					
	100	4	0.04	588	84	0.03	470	0.03	392					

1. Exact ratio.
 2. If input speed is below 1160 RPM, please specify speed and mounting position to ensure proper lubrication.
 3. Overhung load given at a distance equal to one shaft diameter from the face of the output seal.
 4. Overhung load is based on maximum bore size. Use of smaller driven shaft diameter may limit OHL capacity.

5. Overhung loads are based on the output shaft and output bearing capacities only. Check Overhung Load Section for other considerations.
 6. Overhung load and thrust load ratings are computed independent of each other. For combined load applications, contact Winsmith.

Ratings





SINGLE REDUCTION

With Mobil Glygoyle 460 Lubricant

REDUCER SIZE

E17

1.750 CENTER DISTANCE			HORSEPOWER AND TORQUE RATINGS							OVERHUNG LOAD CAPACITIES (lb)			THRUST LOAD CAPACITIES (lb)	
RATIO ¹	INPUT RPM ²	OUTPUT RPM	MECHANICAL							INPUT SHAFT	OUTPUT SHAFT ^{5,6}		OUTPUT SHAFT ⁶	
			1.00 SERVICE FACTOR			1.25 SERVICE FACTOR		1.50 SERVICE FACTOR		ALL SHAFT INPUT MODELS	SOLID ³ SHAFT (e.g. MDNS)	HOLLOW ⁴ SHAFT (e.g. MDSS)	SOLID SHAFT (e.g. MDNS)	HOLLOW SHAFT (e.g. MDSS)
			INPUT HP	OUTPUT TORQUE (lbf-in.)	EFF	INPUT HP	OUTPUT TORQUE (lbf-in.)	INPUT HP	OUTPUT TORQUE (lbf-in.)					
30	2500	83	0.84	525	82	0.67	420	0.56	350	129	650	700	894	1440
	1750	58	0.66	596	84	0.53	477	0.44	397					
	1160	39	0.48	660	84	0.38	528	0.32	440					
	870	29	0.36	659	85	0.29	527	0.24	439					
	600	20	0.25	657	85	0.20	526	0.17	438					
	300	10	0.13	658	83	0.10	526	0.09	439					
	100	3	0.04	655	80	0.03	524	0.03	437					
40	2500	63	0.66	521	79	0.53	417	0.44	347	149	650	700	894	1440
	1750	44	0.52	603	80	0.42	482	0.35	402					
	1160	29	0.39	676	80	0.31	541	0.26	451					
	870	22	0.30	716	82	0.24	573	0.20	477					
	600	15	0.21	716	81	0.17	573	0.14	477					
	300	8	0.11	719	79	0.09	575	0.07	479					
	100	3	0.04	718	77	0.03	574	0.03	479					
50	2500	50	0.53	504	75	0.42	403	0.35	336	171	650	700	894	1440
	1750	35	0.41	558	76	0.33	446	0.27	372					
	1160	23	0.28	564	75	0.22	451	0.19	376					
	870	17	0.21	565	75	0.17	452	0.14	377					
	600	12	0.14	568	77	0.11	454	0.09	379					
	300	6	0.07	567	76	0.06	454	0.05	378					
	100	2	0.02	568	74	0.02	454	0.01	379					
60	2500	42	0.38	413	72	0.30	330	0.25	275	202	650	700	894	1440
	1750	29	0.27	417	72	0.22	334	0.18	278					
	1160	19	0.19	435	72	0.15	348	0.13	290					
	870	15	0.15	459	71	0.12	367	0.10	306					
	600	10	0.11	482	70	0.09	386	0.07	321					
	300	5	0.06	509	73	0.05	407	0.04	339					
	100	2	0.02	528	71	0.02	422	0.01	352					
83	2500	30	0.21	273	63	0.17	218	0.14	182	200	650	700	894	1440
	1750	21	0.16	311	64	0.13	249	0.11	207					
	1160	14	0.12	346	64	0.10	277	0.08	231					
	870	10	0.10	364	63	0.08	291	0.07	243					
	600	7	0.07	382	63	0.06	306	0.05	255					
	300	4	0.04	403	63	0.03	322	0.03	269					
	100	1	0.01	417	63	0.01	334	0.01	278					
100	2500	25	0.15	211	57	0.12	169	0.10	141	125	650	700	894	1440
	1750	18	0.11	236	59	0.09	189	0.07	157					
	1160	12	0.08	257	59	0.06	206	0.05	171					
	870	9	0.06	268	59	0.05	214	0.04	179					
	600	6	0.04	279	59	0.03	223	0.03	186					
	300	3	0.02	292	59	0.02	234	0.01	195					
	100	1	0.01	300	58	0.01	240	0.01	200					

1. Exact ratio.
 2. If input speed is below 1160 RPM, please specify speed and mounting position to ensure proper lubrication.
 3. Overhung load given at a distance equal to one shaft diameter from the face of the output seal.
 4. Overhung load is based on maximum bore size. Use of smaller driven shaft diameter may limit OHL capacity.

5. Overhung loads are based on the output shaft and output bearing capacities only. Check Overhung Load Section for other considerations.
 6. Overhung load and thrust load ratings are computed independent of each other. For combined load applications, contact Winsmith.

Ratings



2D DRAWINGS & 3D MODELS
www.WINSMITH.com





2,000 CENTER DISTANCE			HORSEPOWER AND TORQUE RATINGS							OVERHUNG LOAD CAPACITIES (lb)			THRUST LOAD CAPACITIES (lb)	
RATIO ¹	INPUT RPM ²	OUTPUT RPM	MECHANICAL							INPUT SHAFT ALL SHAFT INPUT MODELS	OUTPUT SHAFT ^{5,6}		OUTPUT SHAFT ⁶	
			1.00 SERVICE FACTOR			1.25 SERVICE FACTOR		1.50 SERVICE FACTOR			SOLID ³ SHAFT (e.g. MDNS)	HOLLOW ⁴ SHAFT (e.g. MDSS)	SOLID SHAFT (e.g. MDNS)	HOLLOW SHAFT (e.g. MDSS)
			INPUT HP	OUTPUT TORQUE (lb-ft-in.)	EFF	INPUT HP	OUTPUT TORQUE (lb-ft-in.)	INPUT HP	OUTPUT TORQUE (lb-ft-in.)					
4	SEE MODIFIED PRODUCT SECTION													
5 HOLLOW OUTPUT 5.33	2500	500	4.42	529	95	3.54	423	2.95	353	300	572	1265	615	1440
	1750	350	3.70	639	96	2.96	511	2.47	426					
	1160	232	2.85	743	96	2.28	594	1.90	495					
	870	174	2.38	830	96	1.90	664	1.59	553					
	600	120	1.88	956	97	1.50	765	1.25	637					
	300	60	1.09	1111	97	0.87	889	0.73	741					
	100	20	0.41	1200	93	0.33	960	0.27	800					
7.5	2500	333	3.37	598	94	2.70	478	2.25	399	300	617	1345	705	1440
	1750	233	2.84	732	95	2.27	586	1.89	488					
	1160	155	2.18	849	95	1.74	679	1.45	566					
	870	116	1.82	950	96	1.46	760	1.21	633					
	600	80	1.36	1035	96	1.09	828	0.91	690					
	300	40	0.72	1088	96	0.58	870	0.48	725					
	100	13	0.25	1085	92	0.20	868	0.17	723					
10	2500	250	2.79	653	93	2.23	522	1.86	435	219	650	1345	798	1440
	1750	175	2.24	769	95	1.79	615	1.49	513					
	1160	116	1.68	863	94	1.34	690	1.12	575					
	870	87	1.25	858	95	1.00	686	0.83	572					
	600	60	0.86	858	95	0.69	686	0.57	572					
	300	30	0.43	859	95	0.34	687	0.29	573					
	100	10	0.15	861	89	0.12	689	0.10	574					
15	2500	167	1.95	665	90	1.56	532	1.30	443	242	650	1345	894	1440
	1750	117	1.59	794	92	1.27	635	1.06	529					
	1160	77	1.06	788	91	0.85	630	0.71	525					
	870	58	0.79	792	92	0.63	634	0.53	528					
	600	40	0.55	796	92	0.44	637	0.37	531					
	300	20	0.29	855	92	0.23	684	0.19	570					
	100	7	0.11	896	87	0.09	717	0.07	597					
20	2500	125	1.57	698	88	1.26	558	1.05	465	236	650	1345	894	1440
	1750	88	1.24	806	90	0.99	645	0.83	537					
	1160	58	0.91	891	90	0.73	713	0.61	594					
	870	44	0.68	890	91	0.54	712	0.45	593					
	600	30	0.46	890	91	0.37	712	0.31	593					
	300	15	0.24	891	90	0.19	713	0.16	594					
	100	5	0.08	887	86	0.06	710	0.05	591					
25	2500	100	1.29	702	86	1.03	562	0.86	468	220	650	1345	894	1440
	1750	70	1.01	803	88	0.81	642	0.67	535					
	1160	46	0.73	865	88	0.58	692	0.49	577					
	870	35	0.54	871	89	0.43	697	0.36	581					
	600	24	0.37	875	89	0.30	700	0.25	583					
	300	12	0.19	876	88	0.15	701	0.13	584					
	100	4	0.07	866	84	0.06	693	0.05	577					

1. Exact ratio.
 2. If input speed is below 1160 RPM, please specify speed and mounting position to ensure proper lubrication.
 3. Overhung load given at a distance equal to one shaft diameter from the face of the output seal.
 4. Overhung load is based on maximum bore size. Use of smaller driven shaft diameter may limit OHL capacity.

5. Overhung loads are based on the output shaft and output bearing capacities only. Check Overhung Load Section for other considerations.
 6. Overhung load and thrust load ratings are computed independent of each other. For combined load applications, contact Winsmith.





SINGLE REDUCTION

With Mobil Glygoyle 460 Lubricant

REDUCER SIZE

E20

2.000 CENTER DISTANCE			HORSEPOWER AND TORQUE RATINGS							OVERHUNG LOAD CAPACITIES (lb)			THRUST LOAD CAPACITIES (lb)	
RATIO ¹	INPUT RPM ²	OUTPUT RPM	MECHANICAL							INPUT SHAFT	OUTPUT SHAFT ^{5,6}		OUTPUT SHAFT ⁶	
			1.00 SERVICE FACTOR			1.25 SERVICE FACTOR		1.50 SERVICE FACTOR		ALL SHAFT INPUT MODELS	SOLID ³ SHAFT (e.g. MDNS)	HOLLOW ⁴ SHAFT (e.g. MDSS)	SOLID SHAFT (e.g. MDNS)	HOLLOW SHAFT (e.g. MDSS)
			INPUT HP	OUTPUT TORQUE (lbf-in.)	EFF	INPUT HP	OUTPUT TORQUE (lbf-in.)	INPUT HP	OUTPUT TORQUE (lbf-in.)					
30	2500	83	1.09	686	83	0.87	549	0.73	457	237	650	1345	894	1440
	1750	58	0.86	788	85	0.69	630	0.57	525					
	1160	39	0.66	920	86	0.53	736	0.44	613					
	870	29	0.53	1016	88	0.42	813	0.35	677					
	600	20	0.40	1084	86	0.32	867	0.27	723					
	300	10	0.21	1083	84	0.17	866	0.14	722					
	100	3	0.07	1080	81	0.06	864	0.05	720					
40	2500	63	0.85	685	80	0.68	548	0.57	457	246	650	1345	894	1440
	1750	44	0.68	795	82	0.54	636	0.45	530					
	1160	29	0.51	920	82	0.41	736	0.34	613					
	870	22	0.41	995	84	0.33	796	0.27	663					
	600	15	0.29	993	83	0.23	794	0.19	662					
	300	8	0.15	993	80	0.12	794	0.10	662					
	100	3	0.05	993	78	0.04	794	0.03	662					
50	2500	50	0.72	693	76	0.58	554	0.48	462	224	650	1345	894	1440
	1750	35	0.56	791	79	0.45	633	0.37	527					
	1160	23	0.41	882	79	0.33	706	0.27	588					
	870	17	0.31	887	80	0.25	710	0.21	591					
	600	12	0.21	891	80	0.17	713	0.14	594					
	300	6	0.11	891	78	0.09	713	0.07	594					
	100	2	0.04	882	75	0.03	706	0.03	588					
60	2500	42	0.59	648	73	0.47	518	0.39	432	224	650	1345	894	1440
	1750	29	0.41	656	74	0.33	525	0.27	437					
	1160	19	0.27	660	74	0.22	528	0.18	440					
	870	15	0.21	664	74	0.17	531	0.14	443					
	600	10	0.15	701	74	0.12	561	0.10	467					
	300	5	0.08	745	75	0.06	596	0.05	497					
	100	2	0.03	775	73	0.02	620	0.02	517					
82	2500	30	0.29	397	66	0.23	318	0.19	265	220	650	1345	894	1440
	1750	21	0.22	437	67	0.18	350	0.15	291					
	1160	14	0.16	486	67	0.13	389	0.11	324					
	870	11	0.13	513	67	0.10	410	0.09	342					
	600	7	0.09	538	67	0.07	430	0.06	359					
	300	4	0.05	568	67	0.04	454	0.03	379					
	100	1	0.02	589	65	0.02	471	0.01	393					
99	2500	25	0.21	311	60	0.17	249	0.14	207	220	650	1345	894	1440
	1750	18	0.16	355	61	0.13	284	0.11	237					
	1160	12	0.12	394	62	0.10	315	0.08	263					
	870	9	0.09	415	62	0.07	332	0.06	277					
	600	6	0.07	435	62	0.06	348	0.05	290					
	300	3	0.04	459	62	0.03	367	0.03	306					
	100	1	0.01	475	60	0.01	380	0.01	317					

1. Exact ratio.
 2. If input speed is below 1160 RPM, please specify speed and mounting position to ensure proper lubrication.
 3. Overhung load given at a distance equal to one shaft diameter from the face of the output seal.
 4. Overhung load is based on maximum bore size. Use of smaller driven shaft diameter may limit OHL capacity.

5. Overhung loads are based on the output shaft and output bearing capacities only. Check Overhung Load Section for other considerations.
 6. Overhung load and thrust load ratings are computed independent of each other. For combined load applications, contact Winsmith.

Ratings



2D DRAWINGS & 3D MODELS
www.WINSMITH.com



SINGLE REDUCTION

With Mobil Glygoyle 460 Lubricant



2.375 CENTER DISTANCE			HORSEPOWER AND TORQUE RATINGS							OVERHUNG LOAD CAPACITIES (lb)			THRUST LOAD CAPACITIES (lb)	
RATIO ¹	INPUT RPM ²	OUTPUT RPM	MECHANICAL							INPUT SHAFT ALL SHAFT INPUT MODELS	OUTPUT SHAFT ^{5,6}		OUTPUT SHAFT ⁶	
			1.00 SERVICE FACTOR			1.25 SERVICE FACTOR		1.50 SERVICE FACTOR			SOLID ³ SHAFT (e.g. MDNS)	HOLLOW ⁴ SHAFT (e.g. MDSS)	SOLID SHAFT (e.g. MDNS)	HOLLOW SHAFT (e.g. MDSS)
			INPUT HP	OUTPUT TORQUE (lb•in.)	EFF	INPUT HP	OUTPUT TORQUE (lb•in.)	INPUT HP	OUTPUT TORQUE (lb•in.)					
4	SEE MODIFIED PRODUCT SECTION													
5	2500	500	6.94	830	95	5.55	664	4.63	553	350	748	1100	844	1643
	1750	350	5.89	1017	96	4.71	814	3.93	678					
	1160	232	4.81	1263	97	3.85	1010	3.21	842					
	870	174	3.97	1394	97	3.18	1115	2.65	929					
	600	120	3.03	1544	97	2.42	1235	2.02	1029					
	300	60	1.73	1754	97	1.38	1403	1.15	1169					
	100	20	0.67	1928	91	0.54	1542	0.45	1285					
7.5	2500	333	5.40	960	94	4.32	768	3.60	640	320	799	1187	968	1909
	1750	233	4.54	1168	95	3.63	934	3.03	779					
	1160	155	3.64	1431	96	2.91	1145	2.43	954					
	870	116	3.01	1581	97	2.41	1265	2.01	1054					
	600	80	2.21	1685	97	1.77	1348	1.47	1123					
	300	40	1.12	1689	96	0.90	1351	0.75	1126					
	100	13	0.40	1692	89	0.32	1354	0.27	1128					
10	2500	250	4.29	1006	93	3.43	805	2.86	671	230	895	1280	1067	1909
	1750	175	3.67	1249	95	2.94	999	2.45	833					
	1160	116	2.55	1321	95	2.04	1057	1.70	881					
	870	87	1.91	1321	95	1.53	1057	1.27	881					
	600	60	1.31	1316	95	1.05	1053	0.87	877					
	300	30	0.68	1353	95	0.54	1082	0.45	902					
	100	10	0.26	1433	88	0.21	1146	0.17	955					
15	2500	167	3.21	1101	91	2.57	881	2.14	734	234	1025	1414	1238	1909
	1750	117	2.71	1359	93	2.17	1087	1.81	906					
	1160	77	1.81	1376	93	1.45	1101	1.21	917					
	870	58	1.36	1381	94	1.09	1105	0.91	921					
	600	40	0.94	1383	94	0.75	1106	0.63	922					
	300	20	0.50	1461	92	0.40	1169	0.33	974					
	100	7	0.19	1545	84	0.15	1236	0.13	1030					
20	2500	125	2.55	1138	88	2.04	910	1.70	759	235	1025	1414	1500	1909
	1750	88	2.11	1383	91	1.69	1106	1.41	922					
	1160	58	1.60	1611	93	1.28	1289	1.07	1074					
	870	44	1.20	1613	93	0.96	1290	0.80	1075					
	600	30	0.76	1464	92	0.61	1171	0.51	976					
	300	15	0.39	1467	90	0.31	1174	0.26	978					
	100	5	0.15	1515	82	0.12	1212	0.10	1010					
25	2500	100	1.98	1068	86	1.58	854	1.32	712	235	1025	1414	1500	1909
	1750	70	1.61	1285	88	1.29	1028	1.07	857					
	1160	46	1.05	1280	89	0.84	1024	0.70	853					
	870	35	0.78	1276	90	0.62	1021	0.52	851					
	600	24	0.56	1311	90	0.45	1049	0.37	874					
	300	12	0.31	1412	88	0.25	1130	0.21	941					
	100	4	0.12	1483	81	0.10	1186	0.08	989					

1. Exact ratio.
 2. If input speed is below 1160 RPM, please specify speed and mounting position to ensure proper lubrication.
 3. Overhung load given at a distance equal to one shaft diameter from the face of the output seal.
 4. Overhung load is based on maximum bore size. Use of smaller driven shaft diameter may limit OHL capacity.

5. Overhung loads are based on the output shaft and output bearing capacities only. Check Overhung Load Section for other considerations.
 6. Overhung load and thrust load ratings are computed independent of each other. For combined load applications, contact Winsmith.

Ratings





SINGLE REDUCTION

With Mobil Glygoyle 460 Lubricant

REDUCER SIZE

E24

2.375 CENTER DISTANCE			HORSEPOWER AND TORQUE RATINGS							OVERHUNG LOAD CAPACITIES (lb)			THRUST LOAD CAPACITIES (lb)	
RATIO ¹	INPUT RPM ²	OUTPUT RPM	MECHANICAL							INPUT SHAFT	OUTPUT SHAFT ^{5,6}		OUTPUT SHAFT ⁶	
			1.00 SERVICE FACTOR			1.25 SERVICE FACTOR		1.50 SERVICE FACTOR		ALL SHAFT INPUT MODELS	SOLID ³ SHAFT (e.g. MDNS)	HOLLOW ⁴ SHAFT (e.g. MDSS)	SOLID SHAFT (e.g. MDNS)	HOLLOW SHAFT (e.g. MDSS)
			INPUT HP	OUTPUT TORQUE (lbf-in.)	EFF	INPUT HP	OUTPUT TORQUE (lbf-in.)	INPUT HP	OUTPUT TORQUE (lbf-in.)					
30	2500	83	1.76	1107	83	1.41	886	1.17	738	235	1025	1414	1500	1909
	1750	58	1.45	1360	87	1.16	1088	0.97	907					
	1160	39	0.94	1350	88	0.75	1080	0.63	900					
	870	29	0.71	1359	88	0.57	1087	0.47	906					
	600	20	0.51	1380	86	0.41	1104	0.34	920					
	300	10	0.28	1498	84	0.22	1198	0.19	999					
	100	3	0.10	1583	80	0.08	1266	0.07	1055					
40	2500	63	1.38	1103	79	1.10	882	0.92	735	235	1025	1414	1500	1909
	1750	44	1.11	1335	83	0.89	1068	0.74	890					
	1160	29	0.73	1333	85	0.58	1066	0.49	889					
	870	22	0.54	1336	85	0.43	1069	0.36	891					
	600	15	0.38	1325	83	0.30	1060	0.25	883					
	300	8	0.21	1430	81	0.17	1144	0.14	953					
	100	3	0.08	1505	77	0.06	1204	0.05	1003					
50	2500	50	1.16	1112	76	0.93	890	0.77	741	235	1025	1414	1500	1909
	1750	35	0.92	1329	80	0.74	1063	0.61	886					
	1160	23	0.63	1421	83	0.50	1137	0.42	947					
	870	17	0.48	1417	82	0.38	1134	0.32	945					
	600	12	0.34	1411	80	0.27	1129	0.23	941					
	300	6	0.17	1422	78	0.14	1138	0.11	948					
	100	2	0.06	1421	74	0.05	1137	0.04	947					
60	2500	42	0.96	1055	72	0.77	844	0.64	703	235	1025	1414	1500	1909
	1750	29	0.70	1134	75	0.56	907	0.47	756					
	1160	19	0.46	1138	77	0.37	910	0.31	759					
	870	15	0.34	1144	78	0.27	915	0.23	763					
	600	10	0.24	1168	77	0.19	934	0.16	779					
	300	5	0.13	1252	75	0.10	1002	0.09	835					
	100	2	0.05	1312	71	0.04	1050	0.03	875					
80	2500	31	0.53	687	65	0.42	550	0.35	458	235	1025	1414	1500	1909
	1750	22	0.38	735	66	0.30	588	0.25	490					
	1160	15	0.29	837	67	0.23	670	0.19	558					
	870	11	0.23	892	68	0.18	714	0.15	595					
	600	8	0.16	947	71	0.13	758	0.11	631					
	300	4	0.08	988	70	0.06	790	0.05	659					
	100	1	0.03	988	64	0.02	790	0.02	659					
100	2500	25	0.34	490	57	0.27	392	0.23	327	235	1025	1414	1500	1909
	1750	18	0.27	576	59	0.22	461	0.18	384					
	1160	12	0.20	654	60	0.16	523	0.13	436					
	870	9	0.16	696	61	0.13	557	0.11	464					
	600	6	0.12	738	61	0.10	590	0.08	492					
	300	3	0.06	788	64	0.05	630	0.04	525					
	100	1	0.02	818	59	0.02	654	0.01	545					

1. Exact ratio.
 2. If input speed is below 1160 RPM, please specify speed and mounting position to ensure proper lubrication.
 3. Overhung load given at a distance equal to one shaft diameter from the face of the output seal.
 4. Overhung load is based on maximum bore size. Use of smaller driven shaft diameter may limit OHL capacity.

5. Overhung loads are based on the output shaft and output bearing capacities only. Check Overhung Load Section for other considerations.
 6. Overhung load and thrust load ratings are computed independent of each other. For combined load applications, contact Winsmith.

Ratings



2D DRAWINGS & 3D MODELS
www.WINSMITH.com



SINGLE REDUCTION
With Mobil Glygoyle 460 Lubricant



2.625 CENTER DISTANCE			HORSEPOWER AND TORQUE RATINGS							OVERHUNG LOAD CAPACITIES (lb)			THRUST LOAD CAPACITIES (lb)	
RATIO ¹	INPUT RPM ²	OUTPUT RPM	MECHANICAL							INPUT SHAFT ALL SHAFT INPUT MODELS	OUTPUT SHAFT ^{5,6}		OUTPUT SHAFT ⁶	
			1.00 SERVICE FACTOR			1.25 SERVICE FACTOR		1.50 SERVICE FACTOR			SOLID ³ SHAFT (e.g. MDNS)	HOLLOW ⁴ SHAFT (e.g. MDSS)	SOLID SHAFT (e.g. MDNS)	HOLLOW SHAFT (e.g. MDSS)
INPUT HP	OUTPUT TORQUE (lbf-in.)	EFF	INPUT HP	OUTPUT TORQUE (lbf-in.)	INPUT HP	OUTPUT TORQUE (lbf-in.)	INPUT HP	OUTPUT TORQUE (lbf-in.)						
4	SEE MODIFIED PRODUCT SECTION													
5	2500	500	9.11	1096	95	7.29	877	6.07	731	500	748	1302	844	1860
	1750	350	7.70	1334	96	6.16	1067	5.13	889					
	1160	232	5.96	1567	97	4.77	1254	3.97	1045					
	870	174	4.99	1756	97	3.99	1405	3.33	1171					
	600	120	3.91	1994	97	3.13	1595	2.61	1329					
	300	60	2.30	2330	96	1.84	1864	1.53	1553					
	100	20	0.91	2584	90	0.73	2067	0.61	1723					
7.5	2500	333	7.08	1268	95	5.66	1014	4.72	845	500	799	1405	968	2160
	1750	233	5.93	1533	96	4.74	1226	3.95	1022					
	1160	155	4.67	1836	97	3.74	1469	3.11	1224					
	870	116	3.92	2066	97	3.14	1653	2.61	1377					
	600	80	3.08	2356	97	2.46	1885	2.05	1571					
	300	40	1.68	2546	96	1.34	2037	1.12	1697					
	100	13	0.60	2542	89	0.48	2034	0.40	1695					
10	2500	250	5.73	1356	94	4.58	1085	3.82	904	250	895	1535	1067	2160
	1750	175	4.82	1650	95	3.86	1320	3.21	1100					
	1160	116	3.41	1770	96	2.73	1416	2.27	1180					
	870	87	2.57	1782	96	2.06	1426	1.71	1188					
	600	60	1.81	1821	96	1.45	1457	1.21	1214					
	300	30	0.95	1888	94	0.76	1510	0.63	1259					
	100	10	0.35	1970	88	0.28	1576	0.23	1313					
15	2500	167	4.14	1434	92	3.31	1147	2.76	956	285	1025	1750	1238	2160
	1750	117	3.42	1724	93	2.74	1379	2.28	1149					
	1160	77	2.41	1847	94	1.93	1478	1.61	1231					
	870	58	1.80	1849	94	1.44	1479	1.20	1233					
	600	40	1.24	1843	94	0.99	1474	0.83	1229					
	300	20	0.68	1999	93	0.54	1599	0.45	1333					
	100	7	0.27	2124	85	0.22	1699	0.18	1416					
20	2500	125	3.16	1426	89	2.53	1141	2.11	951	275	1025	1823	1500	2160
	1750	88	2.64	1745	92	2.11	1396	1.76	1163					
	1160	58	1.76	1764	92	1.41	1411	1.17	1176					
	870	44	1.31	1762	93	1.05	1410	0.87	1175					
	600	30	0.93	1810	93	0.74	1448	0.62	1207					
	300	15	0.52	1968	91	0.42	1574	0.35	1312					
	100	5	0.20	2082	82	0.16	1666	0.13	1388					
25	2500	100	2.63	1455	88	2.10	1164	1.75	970	275	1025	1823	1500	2160
	1750	70	2.17	1758	90	1.74	1406	1.45	1172					
	1160	46	1.43	1762	91	1.14	1410	0.95	1175					
	870	35	1.07	1769	91	0.86	1415	0.71	1179					
	600	24	0.74	1774	91	0.59	1419	0.49	1183					
	300	12	0.41	1920	89	0.33	1536	0.27	1280					
	100	4	0.16	2023	80	0.13	1618	0.11	1349					

Ratings

1. Exact ratio.
 2. If input speed is below 1160 RPM, please specify speed and mounting position to ensure proper lubrication.
 3. Overhung load given at a distance equal to one shaft diameter from the face of the output seal.
 4. Overhung load is based on maximum bore size. Use of smaller driven shaft diameter may limit OHL capacity.

5. Overhung loads are based on the output shaft and output bearing capacities only. Check Overhung Load Section for other considerations.
 6. Overhung load and thrust load ratings are computed independent of each other. For combined load applications, contact Winsmith.

 Mechanical ratings shaded above exceed speed reducer thermal limitations under continuous duty conditions. Refer to Appendix (page 229) for Continuous Duty Thermal Limit Ratings.





SINGLE REDUCTION

With Mobil Glygoyle 460 Lubricant

REDUCER SIZE

E26

2.625 CENTER DISTANCE			HORSEPOWER AND TORQUE RATINGS							OVERHUNG LOAD CAPACITIES (lb)			THRUST LOAD CAPACITIES (lb)	
RATIO ¹	INPUT RPM ²	OUTPUT RPM	MECHANICAL							INPUT SHAFT	OUTPUT SHAFT ^{5,6}		OUTPUT SHAFT ⁶	
			1.00 SERVICE FACTOR			1.25 SERVICE FACTOR		1.50 SERVICE FACTOR		ALL SHAFT INPUT MODELS	SOLID ³ SHAFT (e.g. MDNS)	HOLLOW ⁴ SHAFT (e.g. MDSS)	SOLID SHAFT (e.g. MDNS)	HOLLOW SHAFT (e.g. MDSS)
			INPUT HP	OUTPUT TORQUE (lbf-in.)	EFF	INPUT HP	OUTPUT TORQUE (lbf-in.)	INPUT HP	OUTPUT TORQUE (lbf-in.)					
30	2500	83	2.32	1500	85	1.86	1200	1.55	1000	282	1025	1823	1500	2160
	1750	58	1.80	1712	88	1.44	1370	1.20	1141					
	1160	39	1.28	1864	89	1.02	1491	0.85	1243					
	870	29	0.95	1858	90	0.76	1486	0.63	1239					
	600	20	0.68	1881	88	0.54	1505	0.45	1254					
	300	10	0.38	2055	85	0.30	1644	0.25	1370					
	100	3	0.15	2181	77	0.12	1745	0.10	1454					
40	2500	63	1.82	1499	82	1.46	1199	1.21	999	260	1025	1823	1500	2160
	1750	44	1.42	1737	85	1.14	1390	0.95	1158					
	1160	29	1.06	2028	88	0.85	1622	0.71	1352					
	870	22	0.81	2028	87	0.65	1622	0.54	1352					
	600	15	0.57	2022	84	0.46	1618	0.38	1348					
	300	8	0.29	2019	82	0.23	1615	0.19	1346					
	100	3	0.11	2071	74	0.09	1657	0.07	1381					
50	2500	50	1.48	1461	78	1.18	1169	0.99	974	285	1025	1823	1500	2160
	1750	35	1.18	1748	82	0.94	1398	0.79	1165					
	1160	23	0.84	1932	85	0.67	1546	0.56	1288					
	870	17	0.63	1924	84	0.50	1539	0.42	1283					
	600	12	0.45	1926	82	0.36	1541	0.30	1284					
	300	6	0.23	1934	79	0.18	1547	0.15	1289					
	100	2	0.09	1940	72	0.07	1552	0.06	1293					
60	2500	42	1.22	1387	75	0.98	1110	0.81	925	270	1025	1823	1500	2160
	1750	29	0.92	1556	78	0.74	1245	0.61	1037					
	1160	19	0.60	1562	80	0.48	1250	0.40	1041					
	870	15	0.45	1569	81	0.36	1255	0.30	1046					
	600	10	0.32	1587	79	0.26	1270	0.21	1058					
	300	5	0.18	1710	77	0.14	1368	0.12	1140					
	100	2	0.07	1797	69	0.06	1438	0.05	1198					
80	2500	31	0.69	947	69	0.55	758	0.46	631	270	1025	1823	1500	2160
	1750	22	0.49	979	70	0.39	783	0.33	653					
	1160	15	0.37	1126	69	0.30	901	0.25	751					
	870	11	0.29	1206	72	0.23	965	0.19	804					
	600	8	0.21	1285	74	0.17	1028	0.14	857					
	300	4	0.11	1380	72	0.09	1104	0.07	920					
	100	1	0.04	1395	64	0.03	1116	0.03	930					
100	2500	25	0.42	645	61	0.34	516	0.28	430	270	1025	1823	1500	2160
	1750	18	0.34	767	63	0.27	614	0.23	511					
	1160	12	0.25	880	64	0.20	704	0.17	587					
	870	9	0.20	941	64	0.16	753	0.13	627					
	600	6	0.15	1001	65	0.12	801	0.10	667					
	300	3	0.08	1073	67	0.06	858	0.05	715					
	100	1	0.03	1124	60	0.02	899	0.02	749					

Ratings

1. Exact ratio.
 2. If input speed is below 1160 RPM, please specify speed and mounting position to ensure proper lubrication.
 3. Overhung load given at a distance equal to one shaft diameter from the face of the output seal.
 4. Overhung load is based on maximum bore size. Use of smaller driven shaft diameter may limit OHL capacity.

5. Overhung loads are based on the output shaft and output bearing capacities only. Check Overhung Load Section for other considerations.
 6. Overhung load and thrust load ratings are computed independent of each other. For combined load applications, contact Winsmith.

 Mechanical ratings shaded above exceed speed reducer thermal limitations under continuous duty conditions. Refer to Appendix (page 229) for Continuous Duty Thermal Limit Ratings.



2D DRAWINGS & 3D MODELS
www.WINSMITH.com



SINGLE REDUCTION

With Mobil Glygoyle 460 Lubricant



3.000 CENTER DISTANCE			HORSEPOWER AND TORQUE RATINGS							OVERHUNG LOAD CAPACITIES (lb)			THRUST LOAD CAPACITIES (lb)	
RATIO ¹	INPUT RPM ²	OUTPUT RPM	MECHANICAL							INPUT SHAFT ALL SHAFT INPUT MODELS	OUTPUT SHAFT ^{5,6}		OUTPUT SHAFT ⁶	
			1.00 SERVICE FACTOR			1.25 SERVICE FACTOR		1.50 SERVICE FACTOR			SOLID ³ SHAFT (e.g. MDNS)	HOLLOW ⁴ SHAFT (e.g. MDSS)	SOLID SHAFT (e.g. MDNS)	HOLLOW SHAFT (e.g. MDSS)
INPUT HP	OUTPUT TORQUE (lbf-in.)	EFF	INPUT HP	OUTPUT TORQUE (lbf-in.)	INPUT HP	OUTPUT TORQUE (lbf-in.)	INPUT HP	OUTPUT TORQUE (lbf-in.)						
4	SEE MODIFIED PRODUCT SECTION													
5	2500	500	12.68	1534	96	10.14	1227	8.45	1023	560	1116	1175	1137	1856
	1750	350	10.87	1886	96	8.70	1509	7.25	1257					
	1160	232	8.75	2303	97	7.00	1842	5.83	1535					
	870	174	7.35	2583	97	5.88	2066	4.90	1722					
	600	120	5.73	2913	97	4.58	2330	3.82	1942					
	300	60	3.39	3395	95	2.71	2716	2.26	2263					
	100	20	1.34	3815	90	1.07	3052	0.89	2543					
7.5	2500	333	10.42	1881	95	8.34	1505	6.95	1254	600	1190	1260	1301	2146
	1750	233	8.59	2232	96	6.87	1786	5.73	1488					
	1160	155	7.11	2802	97	5.69	2242	4.74	1868					
	870	116	5.90	3109	97	4.72	2487	3.93	2073					
	600	80	4.69	3575	97	3.75	2860	3.13	2383					
	300	40	2.80	4192	95	2.24	3354	1.87	2795					
	100	13	1.08	4573	89	0.86	3658	0.72	3049					
10	2500	250	8.45	2016	95	6.76	1613	5.63	1344	400	1298	1368	1434	2365
	1750	175	7.11	2448	96	5.69	1958	4.74	1632					
	1160	116	5.31	2768	96	4.25	2214	3.54	1845					
	870	87	3.97	2761	96	3.18	2209	2.65	1841					
	600	60	2.77	2779	95	2.22	2223	1.85	1853					
	300	30	1.51	2949	93	1.21	2359	1.01	1966					
	100	10	0.57	3169	88	0.46	2535	0.38	2113					
15	2500	167	6.04	2120	93	4.83	1696	4.03	1413	450	1350	1583	1724	2711
	1750	117	5.07	2578	94	4.06	2062	3.38	1719					
	1160	77	3.35	2580	94	2.68	2064	2.23	1720					
	870	58	2.53	2595	94	2.02	2076	1.69	1730					
	600	40	1.92	2851	94	1.54	2281	1.28	1901					
	300	20	1.09	3166	92	0.87	2533	0.73	2111					
	100	7	0.42	3394	85	0.34	2715	0.28	2263					
20	2500	125	4.88	2253	92	3.90	1802	3.25	1502	450	1350	1750	1966	2800
	1750	88	3.95	2645	93	3.16	2116	2.63	1763					
	1160	58	2.70	2745	93	2.16	2196	1.80	1830					
	870	44	2.03	2752	94	1.62	2202	1.35	1835					
	600	30	1.44	2831	93	1.15	2265	0.96	1887					
	300	15	0.81	3116	91	0.65	2493	0.54	2077					
	100	5	0.32	3322	83	0.26	2658	0.21	2215					
25	2500	100	3.89	2200	90	3.11	1760	2.59	1467	500	1350	1890	2167	2800
	1750	70	3.24	2676	92	2.59	2141	2.16	1784					
	1160	46	2.19	2749	92	1.75	2199	1.46	1833					
	870	35	1.65	2768	93	1.32	2214	1.10	1845					
	600	24	1.15	2780	92	0.92	2224	0.77	1853					
	300	12	0.65	3042	90	0.52	2434	0.43	2028					
	100	4	0.25	3230	81	0.20	2584	0.17	2153					

1. Exact ratio.
 2. If input speed is below 1160 RPM, please specify speed and mounting position to ensure proper lubrication.
 3. Overhung load given at a distance equal to one shaft diameter from the face of the output seal.
 4. Overhung load is based on maximum bore size. Use of smaller driven shaft diameter may limit OHL capacity.

5. Overhung loads are based on the output shaft and output bearing capacities only. Check Overhung Load Section for other considerations.
 6. Overhung load and thrust load ratings are computed independent of each other. For combined load applications, contact Winsmith.

 Mechanical ratings shaded above exceed speed reducer thermal limitations under continuous duty conditions. Refer to Appendix (page 229) for Continuous Duty Thermal Limit Ratings.





SINGLE REDUCTION

With Mobil Glygoyle 460 Lubricant

REDUCER SIZE

E30

3.000 CENTER DISTANCE			HORSEPOWER AND TORQUE RATINGS							OVERHUNG LOAD CAPACITIES (lb)			THRUST LOAD CAPACITIES (lb)	
RATIO ¹	INPUT RPM ²	OUTPUT RPM	MECHANICAL							INPUT SHAFT	OUTPUT SHAFT ^{5,6}		OUTPUT SHAFT ⁶	
			1.00 SERVICE FACTOR			1.25 SERVICE FACTOR		1.50 SERVICE FACTOR		ALL SHAFT INPUT MODELS	SOLID ³ SHAFT (e.g. MDNS)	HOLLOW ⁴ SHAFT (e.g. MDSS)	SOLID SHAFT (e.g. MDNS)	HOLLOW SHAFT (e.g. MDSS)
			INPUT HP	OUTPUT TORQUE (lbf-in.)	EFF	INPUT HP	OUTPUT TORQUE (lbf-in.)	INPUT HP	OUTPUT TORQUE (lbf-in.)					
30	2500	83	3.42	2272	88	2.74	1818	2.28	1515	500	1350	2020	2400	2800
	1750	58	2.67	2586	90	2.14	2069	1.78	1724					
	1160	39	1.95	2891	91	1.56	2313	1.30	1927					
	870	29	1.46	2894	91	1.17	2315	0.97	1929					
	600	20	1.05	2936	89	0.84	2349	0.70	1957					
	300	10	0.60	3250	86	0.48	2600	0.40	2167					
	100	3	0.24	3478	77	0.19	2782	0.16	2319					
40	2500	63	2.64	2263	85	2.11	1810	1.76	1509	500	1350	2020	2400	2800
	1750	44	2.08	2617	87	1.66	2094	1.39	1745					
	1160	29	1.59	3101	90	1.27	2481	1.06	2067					
	870	22	1.23	3137	88	0.98	2510	0.82	2091					
	600	15	0.87	3133	85	0.70	2506	0.58	2089					
	300	8	0.45	3132	83	0.36	2506	0.30	2088					
	100	3	0.18	3301	73	0.14	2641	0.12	2201					
50	2500	50	2.08	2132	81	1.66	1706	1.39	1421	500	1350	2020	2400	2800
	1750	35	1.72	2643	85	1.38	2114	1.15	1762					
	1160	23	1.29	3057	87	1.03	2446	0.86	2038					
	870	17	0.99	3059	85	0.79	2447	0.66	2039					
	600	12	0.70	3047	83	0.56	2438	0.47	2031					
	300	6	0.36	3067	80	0.29	2454	0.24	2045					
	100	2	0.14	3099	71	0.11	2479	0.09	2066					
60	2500	42	1.72	2033	78	1.38	1626	1.15	1355	500	1350	2020	2400	2800
	1750	29	1.34	2367	82	1.07	1894	0.89	1578					
	1160	19	0.88	2381	83	0.70	1905	0.59	1587					
	870	15	0.67	2395	83	0.54	1916	0.45	1597					
	600	10	0.49	2490	80	0.39	1992	0.33	1660					
	300	5	0.28	2712	78	0.22	2170	0.19	1808					
	100	2	0.11	2798	69	0.09	2238	0.07	1865					
80	2500	31	0.98	1434	72	0.78	1147	0.65	956	500	1350	2580	2400	2800
	1750	22	0.71	1478	73	0.57	1182	0.47	985					
	1160	15	0.54	1735	74	0.43	1388	0.36	1157					
	870	11	0.43	1876	76	0.34	1501	0.29	1251					
	600	8	0.32	2019	76	0.26	1615	0.21	1346					
	300	4	0.17	2050	73	0.14	1640	0.11	1367					
	100	1	0.06	2050	64	0.05	1640	0.04	1367					
100	2500	25	0.58	967	66	0.46	774	0.39	645	500	1350	2580	2400	2800
	1750	18	0.48	1160	67	0.38	928	0.32	773					
	1160	12	0.37	1356	67	0.30	1085	0.25	904					
	870	9	0.30	1465	67	0.24	1172	0.20	977					
	600	6	0.22	1573	70	0.18	1258	0.15	1049					
	300	3	0.12	1696	69	0.10	1357	0.08	1131					
	100	1	0.04	1696	61	0.03	1357	0.03	1131					

Ratings

1. Exact ratio.
 2. If input speed is below 1160 RPM, please specify speed and mounting position to ensure proper lubrication.
 3. Overhung load given at a distance equal to one shaft diameter from the face of the output seal.
 4. Overhung load is based on maximum bore size. Use of smaller driven shaft diameter may limit OHL capacity.

5. Overhung loads are based on the output shaft and output bearing capacities only. Check Overhung Load Section for other considerations.
 6. Overhung load and thrust load ratings are computed independent of each other. For combined load applications, contact Winsmith.

Mechanical ratings shaded above exceed speed reducer thermal limitations under continuous duty conditions. Refer to Appendix (page 229) for Continuous Duty Thermal Limit Ratings.



2D DRAWINGS & 3D MODELS
www.WINSMITH.com



SINGLE REDUCTION

With Mobil Glygoyle 460 Lubricant



Ratings

3.500 CENTER DISTANCE			HORSEPOWER AND TORQUE RATINGS							OVERHUNG LOAD CAPACITIES (lb)			THRUST LOAD CAPACITIES (lb)	
RATIO ¹	INPUT RPM ²	OUTPUT RPM	MECHANICAL							INPUT SHAFT ALL SHAFT INPUT MODELS	OUTPUT SHAFT ^{5,6}		OUTPUT SHAFT ⁶	
			1.00 SERVICE FACTOR			1.25 SERVICE FACTOR		1.50 SERVICE FACTOR			SOLID ³ SHAFT (e.g. MDNS)	HOLLOW ⁴ SHAFT (e.g. MDSS)	SOLID SHAFT (e.g. MDNS)	HOLLOW SHAFT (e.g. MDSS)
			INPUT HP	OUTPUT TORQUE (lbf-in.)	EFF	INPUT HP	OUTPUT TORQUE (lbf-in.)	INPUT HP	OUTPUT TORQUE (lbf-in.)					
4														
	2500	500	18.09	2197	96	14.47	1758	12.06	1465	SEE MODIFIED PRODUCT SECTION				
	1750	350	15.82	2738	96	12.66	2190	10.55	1825					
5	1160	232	12.97	3395	96	10.38	2716	8.65	2263					
	870	174	11.03	3850	96	8.82	3080	7.35	2567					
	600	120	8.71	4398	96	6.97	3518	5.81	2932					
	300	60	5.22	5223	95	4.18	4178	3.48	3482					
	100	20	2.09	5971	90	1.67	4777	1.39	3981					
	2500	333	14.66	2652	96	11.73	2122	9.77	1768					
7.5	1750	233	12.55	3252	96	10.04	2602	8.37	2168	750	1882	1582	1997	2612
	1160	155	10.41	4084	96	8.33	3267	6.94	2723					
	870	116	9.04	4731	96	7.23	3785	6.03	3154					
	600	80	7.17	5425	96	5.74	4340	4.78	3617					
	300	40	3.96	5910	95	3.17	4728	2.64	3940					
	100	13	1.39	5892	90	1.11	4714	0.93	3928					
10	2500	250	12.00	2867	95	9.60	2294	8.00	1911	750	2064	1734	2200	2903
	1750	175	10.27	3515	95	8.22	2812	6.85	2343					
	1160	116	8.51	4413	95	6.81	3530	5.67	2942					
	870	87	7.32	5057	95	5.86	4046	4.88	3371					
	600	60	5.43	5413	95	4.34	4330	3.62	3609					
	300	30	2.75	5383	93	2.20	4306	1.83	3589					
15	2500	167	8.84	3103	93	7.07	2482	5.89	2069	750	2130	1998	2624	3339
	1750	117	7.51	3804	94	6.01	3043	5.01	2536					
	1160	77	6.21	4771	94	4.97	3817	4.14	3181					
	870	58	5.31	5442	94	4.25	4354	3.54	3628					
	600	40	4.15	6152	94	3.32	4922	2.77	4101					
	300	20	2.42	7049	92	1.94	5639	1.61	4699					
20	2500	125	6.91	3189	91	5.53	2551	4.61	2126	750	2130	2204	2973	3660
	1750	88	5.73	3821	93	4.58	3057	3.82	2547					
	1160	58	4.79	4868	93	3.83	3894	3.19	3245					
	870	44	4.04	5484	94	3.23	4387	2.69	3656					
	600	30	3.12	6126	93	2.50	4901	2.08	4084					
	300	15	1.68	6434	91	1.34	5147	1.12	4289					
25	2500	100	5.66	3215	90	4.53	2572	3.77	2143	750	2130	2371	3261	4000
	1750	70	4.71	3884	92	3.77	3107	3.14	2589					
	1160	46	3.87	4871	93	3.10	3897	2.58	3247					
	870	35	3.04	5089	93	2.43	4071	2.03	3393					
	600	24	2.12	5115	92	1.70	4092	1.41	3410					
	300	12	1.09	5118	89	0.87	4094	0.73	3412					
	100	4	0.41	5227	81	0.33	4182	0.27	3485					

1. Exact ratio.
 2. If input speed is below 1160 RPM, please specify speed and mounting position to ensure proper lubrication.
 3. Overhung load given at a distance equal to one shaft diameter from the face of the output seal.
 4. Overhung load is based on maximum bore size. Use of smaller driven shaft diameter may limit OHL capacity.

5. Overhung loads are based on the output shaft and output bearing capacities only. Check Overhung Load Section for other considerations.
 6. Overhung load and thrust load ratings are computed independent of each other. For combined load applications, contact Winsmith.

 Mechanical ratings shaded above exceed speed reducer thermal limitations under continuous duty conditions. Refer to Appendix (page 229) for Continuous Duty Thermal Limit Ratings.





SINGLE REDUCTION

With Mobil Glygoyle 460 Lubricant

REDUCER SIZE

E35

3.500 CENTER DISTANCE			HORSEPOWER AND TORQUE RATINGS							OVERHUNG LOAD CAPACITIES (lb)			THRUST LOAD CAPACITIES (lb)	
RATIO ¹	INPUT RPM ²	OUTPUT RPM	MECHANICAL							INPUT SHAFT	OUTPUT SHAFT ^{5,6}		OUTPUT SHAFT ⁶	
			1.00 SERVICE FACTOR			1.25 SERVICE FACTOR		1.50 SERVICE FACTOR		ALL SHAFT INPUT MODELS	SOLID ³ SHAFT (e.g. MDNS)	HOLLOW ⁴ SHAFT (e.g. MDSS)	SOLID SHAFT (e.g. MDNS)	HOLLOW SHAFT (e.g. MDSS)
			INPUT HP	OUTPUT TORQUE (lbf-in.)	EFF	INPUT HP	OUTPUT TORQUE (lbf-in.)	INPUT HP	OUTPUT TORQUE (lbf-in.)					
30	2500	83	4.84	3216	88	3.87	2573	3.23	2144	750	2130	2528	3520	4000
	1750	58	4.07	3943	90	3.26	3154	2.71	2629					
	1160	39	3.33	4939	91	2.66	3951	2.22	3293					
	870	29	2.84	5618	91	2.27	4494	1.89	3745					
	600	20	2.27	6333	88	1.82	5066	1.51	4222					
	300	10	1.34	7236	85	1.07	5789	0.89	4824					
	100	3	0.49	7343	80	0.39	5874	0.33	4895					
40	2500	63	3.71	3196	85	2.97	2557	2.47	2131	750	2130	2784	3520	4000
	1750	44	3.04	3837	88	2.43	3070	2.03	2558					
	1160	29	2.51	4871	89	2.01	3897	1.67	3247					
	870	22	2.14	5476	88	1.71	4381	1.43	3651					
	600	15	1.70	6108	86	1.36	4886	1.13	4072					
	300	8	0.99	6895	83	0.79	5516	0.66	4597					
	100	3	0.36	7019	78	0.29	5615	0.24	4679					
50	2500	50	2.98	3103	83	2.38	2482	1.99	2069	750	2130	3025	3520	4000
	1750	35	2.44	3753	85	1.95	3002	1.63	2502					
	1160	23	1.97	4695	88	1.58	3756	1.31	3130					
	870	17	1.66	5162	86	1.33	4130	1.11	3441					
	600	12	1.19	5184	83	0.95	4147	0.79	3456					
	300	6	0.62	5183	80	0.50	4146	0.41	3455					
	100	2	0.22	5159	75	0.18	4127	0.15	3439					
60	2500	42	2.44	2944	80	1.95	2355	1.63	1963	750	2130	3186	3520	4000
	1750	29	2.00	3573	83	1.60	2858	1.33	2382					
	1160	19	1.41	3863	84	1.13	3090	0.94	2575					
	870	15	1.07	3883	84	0.86	3106	0.71	2589					
	600	10	0.76	3888	81	0.61	3110	0.51	2592					
	300	5	0.44	4320	78	0.35	3456	0.29	2880					
	100	2	0.17	4645	73	0.14	3716	0.11	3097					
80	2500	31	1.59	2388	75	1.27	1910	1.06	1592	750	2130	3357	3520	4000
	1750	22	1.12	2403	74	0.90	1922	0.75	1602					
	1160	15	0.79	2589	75	0.63	2071	0.53	1726					
	870	11	0.64	2860	77	0.51	2288	0.43	1907					
	600	8	0.49	3136	77	0.39	2509	0.33	2091					
	300	4	0.28	3475	74	0.22	2780	0.19	2317					
	100	1	0.11	3721	67	0.09	2977	0.07	2481					
100	2500	25	0.92	1590	69	0.74	1272	0.61	1060	750	2130	3357	3520	4000
	1750	18	0.67	1666	69	0.54	1333	0.45	1111					
	1160	12	0.54	2023	69	0.43	1618	0.36	1349					
	870	9	0.44	2226	69	0.35	1781	0.29	1484					
	600	6	0.32	2433	71	0.26	1946	0.21	1622					
	300	3	0.18	2686	70	0.14	2149	0.12	1791					
	100	1	0.07	2869	61	0.06	2295	0.05	1913					

1. Exact ratio.
 2. If input speed is below 1160 RPM, please specify speed and mounting position to ensure proper lubrication.
 3. Overhung load given at a distance equal to one shaft diameter from the face of the output seal.
 4. Overhung load is based on maximum bore size. Use of smaller driven shaft diameter may limit OHL capacity.

5. Overhung loads are based on the output shaft and output bearing capacities only. Check Overhung Load Section for other considerations.
 6. Overhung load and thrust load ratings are computed independent of each other. For combined load applications, contact WinSmith.

Mechanical ratings shaded above exceed speed reducer thermal limitations under continuous duty conditions. Refer to Appendix (page 229) for Continuous Duty Thermal Limit Ratings.

Ratings



2D DRAWINGS & 3D MODELS
www.WINSMITH.com



SINGLE REDUCTION

With Mobil Glygoyle 460 Lubricant



4.250 CENTER DISTANCE			HORSEPOWER AND TORQUE RATINGS							OVERHUNG LOAD CAPACITIES (lb)			THRUST LOAD CAPACITIES (lb)		
RATIO ¹	INPUT RPM ²	OUTPUT RPM	MECHANICAL							INPUT SHAFT ALL SHAFT INPUT MODELS	OUTPUT SHAFT ^{5,6}		OUTPUT SHAFT ⁶		
			1.00 SERVICE FACTOR			1.25 SERVICE FACTOR		1.50 SERVICE FACTOR			SOLID ³ SHAFT (e.g. b MDNS)	HOLLOW ⁴ SHAFT (e.g. MDSS)	SOLID SHAFT (e.g. MDNS)	HOLLOW SHAFT (e.g. MDSS)	
			INPUT HP	OUTPUT TORQUE (lbf-in.)	EFF	INPUT HP	OUTPUT TORQUE (lbf-in.)	INPUT HP	OUTPUT TORQUE (lbf-in.)						
4	SEE MODIFIED PRODUCT SECTION														
	5	2500	500	29.24	3574	97	23.39	2859	19.49	2383	1000	2175	2320	2337	3955
		1750	350	25.16	4382	97	20.13	3506	16.77	2921					
		1160	232	21.19	5541	96	16.95	4433	14.13	3694					
		870	174	18.67	6483	96	14.94	5186	12.45	4322					
		600	120	15.62	7811	95	12.50	6249	10.41	5207					
		300	60	9.74	9608	94	7.79	7686	6.49	6405					
100		20	3.81	11031	92	3.05	8825	2.54	7354						
7.5	2500	333	22.38	4065	96	17.90	3252	14.92	2710	1000	2518	2660	2697	4500	
	1750	233	19.39	5011	96	15.51	4009	12.93	3341						
	1160	155	15.87	6149	95	12.70	4919	10.58	4099						
	870	116	14.44	7420	95	11.55	5936	9.63	4947						
	600	80	11.96	8837	94	9.57	7070	7.97	5891						
	300	40	7.39	10731	92	5.91	8585	4.93	7154						
	100	13	2.88	12215	90	2.30	9772	1.92	8143						
10	2500	250	17.88	4287	95	14.30	3430	11.92	2858	1000	2786	2930	2972	4500	
	1750	175	15.84	5400	95	12.67	4320	10.56	3600						
	1160	116	13.06	6666	94	10.45	5333	8.71	4444						
	870	87	11.82	7990	93	9.46	6392	7.88	5327						
	600	60	9.75	9459	92	7.80	7567	6.50	6306						
	300	30	6.01	11409	90	4.81	9127	4.01	7606						
	100	10	2.34	12928	88	1.87	10342	1.56	8619						
15	2500	167	13.03	4595	93	10.42	3676	8.69	3063	1000	2800	3340	3577	4500	
	1750	117	11.63	5819	93	9.30	4655	7.75	3879						
	1160	77	9.66	7211	92	7.73	5769	6.44	4807						
	870	58	8.72	8602	91	6.98	6882	5.81	5735						
	600	40	7.18	10138	90	5.74	8110	4.79	6759						
	300	20	4.43	12168	87	3.54	9734	2.95	8112						
	100	7	1.74	13743	84	1.39	10994	1.16	9162						
20	2500	125	10.46	4840	92	8.37	3872	6.97	3227	1000	2800	3660	4046	4500	
	1750	88	9.16	6007	91	7.33	4806	6.11	4005						
	1160	58	7.69	7511	90	6.15	6009	5.13	5007						
	870	44	6.85	8830	89	5.48	7064	4.57	5887						
	600	30	5.58	10265	88	4.46	8212	3.72	6843						
	300	15	3.40	12135	85	2.72	9708	2.27	8090						
	100	5	1.18	12107	81	0.94	9686	0.79	8071						
25	2500	100	8.65	4879	89	6.92	3903	5.77	3253	1000	2800	3950	4200	4500	
	1750	70	7.50	5981	89	6.00	4785	5.00	3987						
	1160	46	6.24	7402	87	4.99	5922	4.16	4935						
	870	35	5.62	8845	87	4.50	7076	3.75	5897						
	600	24	4.64	10439	86	3.71	8351	3.09	6959						
	300	12	2.94	12550	81	2.35	10040	1.96	8367						
	100	4	1.17	14190	77	0.94	11352	0.78	9460						

1. Exact ratio.
 2. If input speed is below 1160 RPM, please specify speed and mounting position to ensure proper lubrication.
 3. Overhung load given at a distance equal to one shaft diameter from the face of the output seal.
 4. Overhung load is based on maximum bore size. Use of smaller driven shaft diameter may limit OHL capacity.

5. Overhung loads are based on the output shaft and output bearing capacities only. Check Overhung Load Section for other considerations.
 6. Overhung load and thrust load ratings are computed independent of each other. For combined load applications, contact Wincor.

 Mechanical ratings shaded above exceed speed reducer thermal limitations under continuous duty conditions. Refer to Appendix (page 229) for Continuous Duty Thermal Limit Ratings.





SINGLE REDUCTION

With Mobil Glygoyle 460 Lubricant

REDUCER SIZE

E43

4.250 CENTER DISTANCE			HORSEPOWER AND TORQUE RATINGS							OVERHUNG LOAD CAPACITIES (lb)			THRUST LOAD CAPACITIES (lb)	
RATIO ¹	INPUT RPM ²	OUTPUT RPM	MECHANICAL							INPUT SHAFT	OUTPUT SHAFT ^{5,6}		OUTPUT SHAFT ⁶	
			1.00 SERVICE FACTOR			1.25 SERVICE FACTOR		1.50 SERVICE FACTOR		ALL SHAFT INPUT MODELS	SOLID ³ SHAFT (e.g. MDNS)	HOLLOW ⁴ SHAFT (e.g. MDSS)	SOLID SHAFT (e.g. MDNS)	HOLLOW SHAFT (e.g. MDSS)
			INPUT HP	OUTPUT TORQUE (lbf-in.)	EFF	INPUT HP	OUTPUT TORQUE (lbf-in.)	INPUT HP	OUTPUT TORQUE (lbf-in.)					
30	2500	83	7.37	4905	88	5.90	3924	4.91	3270	1000	2800	4260	4200	4500
	1750	58	6.40	6013	87	5.12	4810	4.27	4009					
	1160	39	5.32	7467	86	4.26	5974	3.55	4978					
	870	29	4.76	8882	86	3.81	7106	3.17	5921					
	600	20	3.92	10439	84	3.14	8351	2.61	6959					
	300	10	2.48	12491	80	1.98	9993	1.65	8327					
	100	3	1.00	14079	75	0.80	11263	0.67	9386					
40	2500	63	5.68	4898	85	4.54	3918	3.79	3265	1000	2800	4578	4200	4500
	1750	44	4.94	6005	84	3.95	4804	3.29	4003					
	1160	29	4.09	7515	84	3.27	6012	2.73	5010					
	870	22	3.62	8819	84	2.90	7055	2.41	5879					
	600	15	2.94	10234	83	2.35	8187	1.96	6823					
	300	8	1.84	12075	78	1.47	9660	1.23	8050					
	100	3	0.68	12274	72	0.54	9819	0.45	8183					
50	2500	50	4.56	4774	83	3.65	3819	3.04	3183	1000	2800	4915	4200	4500
	1750	35	3.96	5852	82	3.17	4682	2.64	3901					
	1160	23	3.27	7345	83	2.62	5876	2.18	4897					
	870	17	2.87	8547	82	2.30	6838	1.91	5698					
	600	12	2.13	9032	81	1.70	7226	1.42	6021					
	300	6	1.14	9053	75	0.91	7242	0.76	6035					
	100	2	0.42	9030	69	0.34	7224	0.28	6020					
60	2500	42	3.72	4541	81	2.98	3633	2.48	3027	1000	2800	5210	4200	4500
	1750	29	3.23	5566	80	2.58	4453	2.15	3711					
	1160	19	2.58	6742	80	2.06	5394	1.72	4495					
	870	15	1.97	6781	79	1.58	5425	1.31	4521					
	600	10	1.39	6779	77	1.11	5423	0.93	4519					
	300	5	0.84	7699	73	0.67	6159	0.56	5133					
	100	2	0.32	7993	67	0.26	6394	0.21	5329					
80	2500	31	2.46	3769	76	1.97	3015	1.64	2513	1000	2800	5231	4200	4500
	1750	22	1.91	4144	75	1.53	3315	1.27	2763					
	1160	15	1.31	4189	74	1.05	3351	0.87	2793					
	870	11	1.14	4762	72	0.91	3810	0.76	3175					
	600	8	0.90	5419	72	0.72	4335	0.60	3613					
	300	4	0.56	6256	67	0.45	5005	0.37	4171					
	100	1	0.21	6560	63	0.17	5248	0.14	4373					
100	2500	25	1.19	2123	71	0.95	1698	0.79	1415	1000	2800	5231	4200	4500
	1750	18	1.02	2602	71	0.82	2082	0.68	1735					
	1160	12	0.87	3266	69	0.70	2613	0.58	2177					
	870	9	0.76	3736	68	0.61	2989	0.51	2491					
	600	6	0.61	4235	66	0.49	3388	0.41	2823					
	300	3	0.37	4867	63	0.30	3894	0.25	3245					
	100	1	0.14	5340	60	0.11	4272	0.09	3560					

Ratings

1. Exact ratio.
 2. If input speed is below 1160 RPM, please specify speed and mounting position to ensure proper lubrication.
 3. Overhung load given at a distance equal to one shaft diameter from the face of the output seal.
 4. Overhung load is based on maximum bore size. Use of smaller driven shaft diameter may limit OHL capacity.

5. Overhung loads are based on the output shaft and output bearing capacities only. Check Overhung Load Section for other considerations.
 6. Overhung load and thrust load ratings are computed independent of each other. For combined load applications, contact Winsmith.

 Mechanical ratings shaded above exceed speed reducer thermal limitations under continuous duty conditions. Refer to Appendix (page 229) for Continuous Duty Thermal Limit Ratings.



2D DRAWINGS & 3D MODELS
www.WINSMITH.com



DOUBLE REDUCTION

With Mobil Glygoyle 460 Lubricant



CENTER DISTANCE DOUBLE WORM HELICAL WORM		PRIMARY 1.333 N/A	SECONDARY 1.750 N/A	HORSEPOWER AND TORQUE RATINGS								OVERHUNG LOAD CAPACITIES (lb)			THRUST LOAD CAPACITIES (lb)		
OVERALL RATIO ¹	PRIMARY RATIO ¹	SECONDARY RATIO ¹	INPUT RPM ²	OUTPUT RPM	MECHANICAL								ALL SHAFT INPUT MODELS	OUTPUT SHAFT ^{5,6}		OUTPUT SHAFT ⁶	
					1.00 SERVICE FACTOR		1.25 SERVICE FACTOR		1.50 SERVICE FACTOR		SOLID ³ SHAFT (e.g. MDND)	HOLLOW ⁴ SHAFT (e.g. MDSD)		SOLID SHAFT (e.g. MDND)	HOLLOW SHAFT (e.g. MDSD)		
					INPUT HP	OUTPUT TORQUE (lb·in.)	EFF	INPUT HP	OUTPUT TORQUE (lb·in.)	INPUT HP						OUTPUT TORQUE (lb·in.)	
50(D)	10	5	2500	50.0	0.689	762	88	0.551	610	0.459	508	125	572	1265	615	823	
			1750	35.0	0.487	781	89	0.390	625	0.325	521						
			1160	23.2	0.328	797	89	0.262	638	0.219	531						
			870	17.4	0.248	805	90	0.198	644	0.165	537						
			600	12.0	0.173	812	89	0.138	650	0.115	541						
			300	6.0	0.088	820	89	0.070	656	0.059	547						
			100	2.0	0.03	825	88	0.024	660	0.020	550						
75(D)	5	15	2500	33.3	0.36	564	83	0.288	451	0.240	376	136	650	1345	894	1310	
			1750	23.3	0.258	593	85	0.206	474	0.172	395						
			1160	15.5	0.167	589	86	0.134	471	0.111	393						
			870	11.6	0.127	596	87	0.102	477	0.085	397						
			600	8.0	0.089	603	86	0.071	482	0.059	402						
			300	4.0	0.046	611	85	0.037	489	0.031	407						
			100	1.3	0.015	616	84	0.012	493	0.010	411						
100(D)	5	20	2500	25.0	0.307	632	82	0.246	506	0.205	421	136	650	1345	894	1440	
			1750	17.5	0.221	671	84	0.177	537	0.147	447						
			1160	11.6	0.138	638	85	0.110	510	0.092	425						
			870	8.7	0.105	652	85	0.084	522	0.070	435						
			600	6.0	0.075	665	84	0.060	532	0.050	443						
			300	3.0	0.037	652	84	0.030	522	0.025	435						
			100	1.0	0.013	657	83	0.010	526	0.009	438						
150(D)	10	15	2500	16.7	0.194	587	80	0.155	470	0.129	391	125	650	1345	894	1310	
			1750	11.7	0.135	596	81	0.108	477	0.090	397						
			1160	7.7	0.091	603	82	0.073	482	0.061	402						
			870	5.8	0.068	607	82	0.054	486	0.045	405						
			600	4.0	0.047	611	82	0.038	489	0.031	407						
			300	2.0	0.023	615	83	0.018	492	0.015	410						
			100	0.7	0.008	617	82	0.006	494	0.005	411						

1. Exact ratio.
 2. If input speed is below 1160 RPM, please specify speed and mounting position to ensure proper lubrication.
 3. Overhung load given at a distance equal to one shaft diameter from the face of the output seal.
 4. Overhung load is based on maximum bore size. Use of smaller driven shaft diameter may limit OHL capacity.

5. Overhung loads are based on the output shaft and output bearing capacities only. Check Overhung Load Section for other considerations.
 6. Overhung load and thrust load ratings are computed independent of each other. For combined load applications, contact Winsmith.

Ratings





DOUBLE REDUCTION

With Mobil Glygoyle 460 Lubricant

REDUCER SIZE

E17

CENTER DISTANCE DOUBLE WORM HELICAL WORM		PRIMARY 1.333 N/A	SECONDARY 1.750 N/A	HORSEPOWER AND TORQUE RATINGS								OVERHUNG LOAD CAPACITIES (lb)			THRUST LOAD CAPACITIES (lb)		
OVERALL RATIO ¹	PRIMARY RATIO ¹	SECONDARY RATIO ¹	INPUT RPM ²	OUTPUT RPM	MECHANICAL								ALL SHAFT INPUT MODELS	SOLID ³ SHAFT (e.g. MDND)	HOLLOW ⁴ SHAFT (e.g. MDSD)	OUTPUT SHAFT ⁶	
					1.00 SERVICE FACTOR			1.25 SERVICE FACTOR			1.50 SERVICE FACTOR					SOLID SHAFT (e.g. MDND)	HOLLOW SHAFT (e.g. MDSD)
					INPUT HP	OUTPUT TORQUE (lb·in.)	EFF	INPUT HP	OUTPUT TORQUE (lb·in.)	INPUT HP	OUTPUT TORQUE (lb·in.)						
200(D)	10	20	2500	12.5	0.16	633	79	0.128	506	0.107	422	125	650	1345	894	1440	
			1750	8.8	0.113	652	80	0.090	522	0.075	435						
			1160	5.8	0.076	666	80	0.061	533	0.051	444						
			870	4.4	0.056	648	80	0.045	518	0.037	432						
			600	3.0	0.038	652	81	0.030	522	0.025	435						
			300	1.5	0.019	655	82	0.015	524	0.013	437						
100	0.5	0.006	658	81	0.005	526	0.004	439									
300(D)	20	15	2500	8.3	0.113	602	70	0.090	482	0.075	401	100	650	1345	894	1310	
			1750	5.8	0.078	607	72	0.062	486	0.052	405						
			1160	3.9	0.051	611	74	0.041	489	0.034	407						
			870	2.9	0.037	613	75	0.030	490	0.025	409						
			600	2.0	0.025	615	77	0.020	492	0.017	410						
			300	1.0	0.012	617	78	0.010	494	0.008	411						
100	0.3	0.004	618	78	0.003	494	0.003	412									
500(D)	25	20	2500	5.0	0.077	646	66	0.062	517	0.051	431	100	650	1345	894	1440	
			1750	3.5	0.053	650	68	0.042	520	0.035	433						
			1160	2.3	0.034	653	72	0.027	522	0.023	435						
			870	1.7	0.025	655	73	0.020	524	0.017	437						
			600	1.2	0.017	656	75	0.014	525	0.011	437						
			300	0.6	0.008	658	77	0.006	526	0.005	439						
100	0.2	0.003	659	75	0.002	527	0.002	439									
750(D)	25	30	2500	3.3	0.055	655	63	0.044	524	0.037	437	100	650	1345	894	1440	
			1750	2.3	0.037	659	66	0.030	527	0.025	439						
			1160	1.6	0.024	662	69	0.019	530	0.016	441						
			870	1.2	0.017	664	70	0.014	531	0.011	443						
			600	0.8	0.012	665	72	0.010	532	0.008	443						
			300	0.4	0.006	667	74	0.005	534	0.004	445						
100	0.1	0.002	668	73	0.002	534	0.001	445									

1. Exact ratio.
 2. If input speed is below 1160 RPM, please specify speed and mounting position to ensure proper lubrication.
 3. Overhung load given at a distance equal to one shaft diameter from the face of the output seal.
 4. Overhung load is based on maximum bore size. Use of smaller driven shaft diameter may limit OHL capacity.

5. Overhung loads are based on the output shaft and output bearing capacities only. Check Overhung Load Section for other considerations.
 6. Overhung load and thrust load ratings are computed independent of each other. For combined load applications, contact Winsmith.

Ratings



2D DRAWINGS & 3D MODELS
www.WINSMITH.com



DOUBLE REDUCTION

With Mobil Glygoyle 460 Lubricant



CENTER DISTANCE DOUBLE WORM HELICAL WORM		PRIMARY 1.333 N/A	SECONDARY 1.750 N/A	HORSEPOWER AND TORQUE RATINGS								OVERHUNG LOAD CAPACITIES (lb)			THRUST LOAD CAPACITIES (lb)		
OVERALL RATIO ¹	PRIMARY RATIO ¹	SECONDARY RATIO ¹	INPUT RPM ²	OUTPUT RPM	MECHANICAL								ALL SHAFT INPUT MODELS	OUTPUT SHAFT ^{5,6}		OUTPUT SHAFT ⁶	
					1.00 SERVICE FACTOR		1.25 SERVICE FACTOR		1.50 SERVICE FACTOR		SOLID ³ SHAFT (e.g. MDND)	HOLLOW ⁴ SHAFT (e.g. MDSD)		SOLID SHAFT (e.g. MDND)	HOLLOW SHAFT (e.g. MDSD)		
			INPUT HP	OUTPUT TORQUE (lbf-in.)	EFF	INPUT HP	OUTPUT TORQUE (lbf-in.)	INPUT HP	OUTPUT TORQUE (lbf-in.)	INPUT HP	OUTPUT TORQUE (lbf-in.)						
1000(D)	50	20	2500	2.5	0.052	653	50	0.042	522	0.035	435	100	650	1345	894	1440	
			1750	1.8	0.033	655	55	0.026	524	0.022	437						
			1160	1.2	0.02	656	59	0.016	525	0.013	437						
			870	0.9	0.015	657	62	0.012	526	0.010	438						
			600	0.6	0.01	658	64	0.008	526	0.007	439						
			300	0.3	0.005	659	67	0.004	527	0.003	439						
			100	0.1	0.002	659	67	0.002	527	0.001	439						
1500(D)	50	30	2500	1.7	0.032	662	55	0.026	530	0.021	441	100	650	1345	894	1440	
			1750	1.2	0.022	664	56	0.018	531	0.015	443						
			1160	0.8	0.014	666	57	0.011	533	0.009	444						
			870	0.6	0.011	666	58	0.009	533	0.007	444						
			600	0.4	0.007	667	58	0.006	534	0.005	445						
			300	0.2	0.004	668	59	0.003	534	0.003	445						
			100	-	0.001	668	59	0.001	534	0.001	445						
2000(D)	50	40	2500	1.3	0.031	725	47	0.025	580	0.021	483	100	650	1345	894	1440	
			1750	0.9	0.02	727	52	0.016	582	0.013	485						
			1160	0.6	0.012	729	56	0.010	583	0.008	486						
			870	0.4	0.009	730	58	0.007	584	0.006	487						
			600	0.3	0.006	731	61	0.005	585	0.004	487						
			300	0.2	0.003	731	64	0.002	585	0.002	487						
			100	-	0.001	732	64	0.001	586	0.001	488						
3000(D)	60	50	2500	0.8	0.022	703	43	0.018	562	0.015	469	115	650	1345	894	1440	
			1750	0.6	0.015	749	47	0.012	599	0.010	499						
			1160	0.4	0.009	762	52	0.007	610	0.006	508						
			870	0.3	0.006	763	54	0.005	610	0.004	509						
			600	0.2	0.004	763	56	0.003	610	0.003	509						
			300	0.1	0.002	764	59	0.002	611	0.001	509						
			100	-	0.001	765	59	0.001	612	0.001	510						

1. Exact ratio.
 2. If input speed is below 1160 RPM, please specify speed and mounting position to ensure proper lubrication.
 3. Overhung load given at a distance equal to one shaft diameter from the face of the output seal.
 4. Overhung load is based on maximum bore size. Use of smaller driven shaft diameter may limit OHL capacity.

5. Overhung loads are based on the output shaft and output bearing capacities only. Check Overhung Load Section for other considerations.
 6. Overhung load and thrust load ratings are computed independent of each other. For combined load applications, contact Winsmith.

Ratings





DOUBLE REDUCTION

With Mobil Glygoyle 460 Lubricant

REDUCER SIZE

E17

CENTER DISTANCE DOUBLE WORM HELICAL WORM		PRIMARY 1.333 N/A	SECONDARY 1.750 N/A	HORSEPOWER AND TORQUE RATINGS								OVERHUNG LOAD CAPACITIES (lb)			THRUST LOAD CAPACITIES (lb)		
OVERALL RATIO ¹	PRIMARY RATIO ¹	SECONDARY RATIO ¹	INPUT RPM ²	OUTPUT RPM	MECHANICAL								ALL SHAFT INPUT MODELS	OUTPUT SHAFT ^{5,6}		OUTPUT SHAFT ⁶	
					1.00 SERVICE FACTOR		1.25 SERVICE FACTOR		1.50 SERVICE FACTOR		SOLID ³ SHAFT (e.g. MDND)	HOLLOW ⁴ SHAFT (e.g. MDSD)		SOLID SHAFT (e.g. MDND)	HOLLOW SHAFT (e.g. MDSD)		
					INPUT HP	OUTPUT TORQUE (lbf-in.)	EFF	INPUT HP	OUTPUT TORQUE (lbf-in.)	INPUT HP						OUTPUT TORQUE (lbf-in.)	
3600(D)	60	60	2500	0.7	0.015	540	40	0.012	432	0.010	360	115	650	1345	894	1440	
			1750	0.5	0.01	581	45	0.008	465	0.007	387						
			1160	0.3	0.006	591	49	0.005	473	0.004	394						
			870	0.2	0.004	594	52	0.003	475	0.003	396						
			600	0.2	0.003	598	54	0.002	478	0.002	399						
			300	0.1	0.001	605	57	0.001	484	0.001	403						
100	-	0	608	57	0.000	486	0.000	405									
4150(D)	50	83	2500	0.6	0.011	421	38	0.009	337	0.007	281	100	650	1345	894	1440	
			1750	0.4	0.007	422	42	0.006	338	0.005	281						
			1160	0.3	0.004	427	46	0.003	342	0.003	285						
			870	0.2	0.003	432	48	0.002	346	0.002	288						
			600	0.1	0.002	437	51	0.002	350	0.001	291						
			300	0.1	0.001	442	54	0.001	354	0.001	295						
100	-	0	447	55	0.000	358	0.000	298									
4980(D)	60	83	2500	0.5	0.01	422	35	0.008	338	0.007	281	115	650	1345	894	1440	
			1750	0.4	0.006	423	39	0.005	338	0.004	282						
			1160	0.2	0.004	430	44	0.003	344	0.003	287						
			870	0.2	0.003	435	46	0.002	348	0.002	290						
			600	0.1	0.002	440	48	0.002	352	0.001	293						
			300	0.1	0.001	444	52	0.001	355	0.001	296						
100	-	0	447	52	0.000	358	0.000	298									
6000(D)	60	100	2500	0.4	0.006	303	32	0.005	242	0.004	202	115	650	1345	894	1440	
			1750	0.3	0.004	303	36	0.003	242	0.003	202						
			1160	0.2	0.002	304	40	0.002	243	0.001	203						
			870	0.2	0.002	304	43	0.002	243	0.001	203						
			600	0.1	0.001	304	45	0.001	243	0.001	203						
			300	0.1	0	304	49	0.000	243	0.000	203						
100	-	0	305	50	0.000	244	0.000	203									

1. Exact ratio.
 2. If input speed is below 1160 RPM, please specify speed and mounting position to ensure proper lubrication.
 3. Overhung load given at a distance equal to one shaft diameter from the face of the output seal.
 4. Overhung load is based on maximum bore size. Use of smaller driven shaft diameter may limit OHL capacity.

5. Overhung loads are based on the output shaft and output bearing capacities only. Check Overhung Load Section for other considerations.
 6. Overhung load and thrust load ratings are computed independent of each other. For combined load applications, contact Winsmith.

Ratings



2D DRAWINGS & 3D MODELS
www.WINSMITH.com



DOUBLE REDUCTION

With Mobil Glygoyle 460 Lubricant



CENTER DISTANCE DOUBLE WORM HELICAL WORM		PRIMARY 1.333 N/A	SECONDARY 2.000 N/A	HORSEPOWER AND TORQUE RATINGS								OVERHUNG LOAD CAPACITIES (lb)			THRUST LOAD CAPACITIES (lb)		
OVERALL RATIO ¹	PRIMARY RATIO ¹	SECONDARY RATIO ¹	INPUT RPM ²	OUTPUT RPM	MECHANICAL								ALL SHAFT INPUT MODELS	OUTPUT SHAFT ^{5,6}		OUTPUT SHAFT ⁶	
					1.00 SERVICE FACTOR			1.25 SERVICE FACTOR			1.50 SERVICE FACTOR			SOLID ³ SHAFT (e.g. MDND)	HOLLOW ⁴ SHAFT (e.g. MDSD)	SOLID SHAFT (e.g. MDND)	HOLLOW SHAFT (e.g. MDSD)
					INPUT HP	OUTPUT TORQUE (lbf-in.)	EFF	INPUT HP	OUTPUT TORQUE (lbf-in.)	INPUT HP	OUTPUT TORQUE (lbf-in.)						
SOLID OUTPUT 50(D) HOLLOW OUTPUT 53.3(D)	10	5	2500	50.0	0.955	1056	88	0.764	845	0.637	704	125	572	1265	615	1440	
			1750	35.0	0.727	1166	89	0.582	933	0.485	777						
			1160	23.2	0.494	1192	89	0.395	954	0.329	795						
	10	5	870	17.4	0.374	1206	89	0.299	965	0.249	804						
			600	12.0	0.262	1218	89	0.210	974	0.175	812						
			300	6.0	0.134	1232	87	0.107	986	0.089	821						
100	2.0	0.046	1241	86	0.037	993	0.031	827									
75(D)	5	15	2500	33.3	0.513	815	84	0.410	652	0.342	543	136	650	1345	894	1440	
			1750	23.3	0.364	845	86	0.291	676	0.243	563						
			1160	15.5	0.245	869	87	0.196	695	0.163	579						
			870	11.6	0.187	881	87	0.150	705	0.125	587						
			600	8.0	0.133	892	85	0.106	714	0.089	595						
			300	4.0	0.069	905	84	0.055	724	0.046	603						
			100	1.3	0.023	914	83	0.018	731	0.015	609						
100(D)	5	20	2500	25.0	0.418	872	83	0.334	698	0.279	581	136	650	1345	894	1440	
			1750	17.5	0.304	930	85	0.243	744	0.203	620						
			1160	11.6	0.189	876	86	0.151	701	0.126	584						
			870	8.7	0.146	900	85	0.117	720	0.097	600						
			600	6.0	0.105	923	84	0.084	738	0.070	615						
			300	3.0	0.052	895	82	0.042	716	0.035	597						
			100	1.0	0.018	903	81	0.014	722	0.012	602						
150(D)	10	15	2500	16.7	0.284	865	81	0.227	692	0.189	577	125	650	1345	894	1440	
			1750	11.7	0.199	881	82	0.159	705	0.133	587						
			1160	7.7	0.135	893	81	0.108	714	0.090	595						
			870	5.8	0.102	899	81	0.082	719	0.068	599						
			600	4.0	0.071	905	81	0.057	724	0.047	603						
			300	2.0	0.035	911	82	0.028	729	0.023	607						
			100	0.7	0.012	916	80	0.010	733	0.008	611						

1. Exact ratio.
 2. If input speed is below 1160 RPM, please specify speed and mounting position to ensure proper lubrication.
 3. Overhung load given at a distance equal to one shaft diameter from the face of the output seal.
 4. Overhung load is based on maximum bore size. Use of smaller driven shaft diameter may limit OHL capacity.

5. Overhung loads are based on the output shaft and output bearing capacities only. Check Overhung Load Section for other considerations.
 6. Overhung load and thrust load ratings are computed independent of each other. For combined load applications, contact Winsmith.

Ratings



DOUBLE REDUCTION

With Mobil Glygoyle 460 Lubricant

REDUCER SIZE

E20

CENTER DISTANCE DOUBLE WORM HELICAL WORM		PRIMARY 1.333 N/A	SECONDARY 2.000 N/A	HORSEPOWER AND TORQUE RATINGS								OVERHUNG LOAD CAPACITIES (lb)			THRUST LOAD CAPACITIES (lb)		
OVERALL RATIO ¹	PRIMARY RATIO ¹	SECONDARY RATIO ¹	INPUT RPM ²	OUTPUT RPM	MECHANICAL								ALL SHAFT INPUT MODELS	OUTPUT SHAFT ^{5,6}		OUTPUT SHAFT ⁶	
					1.00 SERVICE FACTOR		1.25 SERVICE FACTOR		1.50 SERVICE FACTOR		SOLID ³ SHAFT (e.g. MDND)	HOLLOW ⁴ SHAFT (e.g. MDSD)		SOLID SHAFT (e.g. MDND)	HOLLOW SHAFT (e.g. MDSD)		
					INPUT HP	OUTPUT TORQUE (lbf-in.)	EFF	INPUT HP	OUTPUT TORQUE (lbf-in.)	INPUT HP						OUTPUT TORQUE (lbf-in.)	
200(D)	10	20	2500	12.5	0.218	869	79	0.174	695	0.145	579	125	650	1345	894	1440	
			1750	8.8	0.155	900	80	0.124	720	0.103	600						
			1160	5.8	0.107	925	80	0.086	740	0.071	617						
			870	4.4	0.077	890	80	0.062	712	0.051	593						
			600	3.0	0.054	895	79	0.043	716	0.036	597						
			300	1.5	0.027	901	81	0.022	721	0.018	601						
			100	0.5	0.009	905	79	0.007	724	0.006	603						
300(D)	20	15	2500	8.3	0.168	891	70	0.134	713	0.112	594	100	650	1345	894	1440	
			1750	5.8	0.116	899	72	0.093	719	0.077	599						
			1160	3.9	0.076	905	73	0.061	724	0.051	603						
			870	2.9	0.056	908	74	0.045	726	0.037	605						
			600	2.0	0.038	911	75	0.030	729	0.025	607						
			300	1.0	0.019	915	77	0.015	732	0.013	610						
			100	0.3	0.006	917	76	0.005	734	0.004	611						
500(D)	25	20	2500	5.0	0.108	887	65	0.086	710	0.072	591	100	650	1345	894	1440	
			1750	3.5	0.074	893	67	0.059	714	0.049	595						
			1160	2.3	0.047	898	70	0.038	718	0.031	599						
			870	1.7	0.035	900	72	0.028	720	0.023	600						
			600	1.2	0.024	902	73	0.019	722	0.016	601						
			300	0.6	0.012	905	75	0.010	724	0.008	603						
			100	0.2	0.004	906	73	0.003	725	0.003	604						
750(D)	25	30	2500	3.3	0.09	1080	63	0.072	864	0.060	720	100	650	1345	894	1440	
			1750	2.3	0.062	1088	65	0.050	870	0.041	725						
			1160	1.6	0.04	1094	68	0.032	875	0.027	729						
			870	1.2	0.029	1097	69	0.023	878	0.019	731						
			600	0.8	0.02	1099	70	0.016	879	0.013	733						
			300	0.4	0.01	1103	72	0.008	882	0.007	735						
			100	0.1	0.003	1105	71	0.002	884	0.002	737						

1. Exact ratio.
 2. If input speed is below 1160 RPM, please specify speed and mounting position to ensure proper lubrication.
 3. Overhung load given at a distance equal to one shaft diameter from the face of the output seal.
 4. Overhung load is based on maximum bore size. Use of smaller driven shaft diameter may limit OHL capacity.

5. Overhung loads are based on the output shaft and output bearing capacities only. Check Overhung Load Section for other considerations.
 6. Overhung load and thrust load ratings are computed independent of each other. For combined load applications, contact Winsmith.

Ratings



2D DRAWINGS & 3D MODELS
www.WINSMITH.com



DOUBLE REDUCTION

With Mobil Glygoyle 460 Lubricant



CENTER DISTANCE DOUBLE WORM HELICAL WORM		PRIMARY 1.333 N/A	SECONDARY 2.000 N/A	HORSEPOWER AND TORQUE RATINGS								OVERHUNG LOAD CAPACITIES (lb)			THRUST LOAD CAPACITIES (lb)		
OVERALL RATIO ¹	PRIMARY RATIO ¹	SECONDARY RATIO ¹	INPUT RPM ²	OUTPUT RPM	MECHANICAL								ALL SHAFT INPUT MODELS	OUTPUT SHAFT ^{5,6}		OUTPUT SHAFT ⁶	
					1.00 SERVICE FACTOR			1.25 SERVICE FACTOR			1.50 SERVICE FACTOR			SOLID ³ SHAFT (e.g. MDND)	HOLLOW ⁴ SHAFT (e.g. MDSD)	SOLID SHAFT (e.g. MDND)	HOLLOW SHAFT (e.g. MDSD)
					INPUT HP	OUTPUT TORQUE (lb-in.)	EFF	INPUT HP	OUTPUT TORQUE (lb-in.)	INPUT HP	OUTPUT TORQUE (lb-in.)						
1000(D)	50	20	2500	2.5	0.073	897	49	0.058	718	0.049	598	100	650	1345	894	1440	
			1750	1.8	0.047	900	54	0.038	720	0.031	600						
			1160	1.2	0.029	903	58	0.023	722	0.019	602						
			870	0.9	0.021	904	60	0.017	723	0.014	603						
			600	0.6	0.014	905	63	0.011	724	0.009	603						
			300	0.3	0.007	906	65	0.006	725	0.005	604						
			100	0.1	0.002	907	65	0.002	726	0.001	605						
1500(D)	50	30	2500	1.7	0.053	1093	54	0.042	874	0.035	729	100	650	1345	894	1440	
			1750	1.2	0.037	1097	55	0.030	878	0.025	731						
			1160	0.8	0.024	1100	56	0.019	880	0.016	733						
			870	0.6	0.018	1101	57	0.014	881	0.012	734						
			600	0.4	0.012	1103	56	0.010	882	0.008	735						
			300	0.2	0.006	1104	58	0.005	883	0.004	736						
			100	-	0.002	1105	57	0.002	884	0.001	737						
2000(D)	50	40	2500	1.3	0.044	1004	46	0.035	803	0.029	669	100	650	1345	894	1440	
			1750	0.9	0.028	1007	50	0.022	806	0.019	671						
			1160	0.6	0.017	1010	54	0.014	808	0.011	673						
			870	0.4	0.012	1011	56	0.010	809	0.008	674						
			600	0.3	0.008	1012	59	0.006	810	0.005	675						
			300	0.2	0.004	1014	62	0.003	811	0.003	676						
			100	-	0.001	1015	61	0.001	812	0.001	677						
3000(D)	60	50	2500	0.8	0.034	1067	42	0.027	854	0.023	711	115	650	1345	894	1440	
			1750	0.6	0.021	1070	46	0.017	856	0.014	713						
			1160	0.4	0.013	1072	50	0.010	858	0.009	715						
			870	0.3	0.009	1073	53	0.007	858	0.006	715						
			600	0.2	0.006	1074	55	0.005	859	0.004	716						
			300	0.1	0.003	1076	58	0.002	861	0.002	717						
			100	-	0.001	1076	57	0.001	861	0.001	717						

1. Exact ratio.
 2. If input speed is below 1160 RPM, please specify speed and mounting position to ensure proper lubrication.
 3. Overhung load given at a distance equal to one shaft diameter from the face of the output seal.
 4. Overhung load is based on maximum bore size. Use of smaller driven shaft diameter may limit OHL capacity.

5. Overhung loads are based on the output shaft and output bearing capacities only. Check Overhung Load Section for other considerations.
 6. Overhung load and thrust load ratings are computed independent of each other. For combined load applications, contact Winsmith.

Ratings





DOUBLE REDUCTION

With Mobil Glygoyle 460 Lubricant

REDUCER SIZE

E20

CENTER DISTANCE DOUBLE WORM HELICAL WORM		PRIMARY 1.333 N/A	SECONDARY 2.000 N/A	HORSEPOWER AND TORQUE RATINGS								OVERHUNG LOAD CAPACITIES (lb)			THRUST LOAD CAPACITIES (lb)		
OVERALL RATIO ¹	PRIMARY RATIO ¹	SECONDARY RATIO ¹	INPUT RPM ²	OUTPUT RPM	MECHANICAL								ALL SHAFT INPUT MODELS	OUTPUT SHAFT ^{5,6}		OUTPUT SHAFT ⁶	
					1.00 SERVICE FACTOR			1.25 SERVICE FACTOR			1.50 SERVICE FACTOR			SOLID ³ SHAFT (e.g. MDND)	HOLLOW ⁴ SHAFT (e.g. MDSD)	SOLID SHAFT (e.g. MDND)	HOLLOW SHAFT (e.g. MDSD)
					INPUT HP	OUTPUT TORQUE (lb·in.)	EFF	INPUT HP	OUTPUT TORQUE (lb·in.)	INPUT HP	OUTPUT TORQUE (lb·in.)						
3600(D)	60	60	2500	0.7	0.023	834	40	0.018	667	0.015	556	115	650	1345	894	1440	
			1750	0.5	0.016	893	44	0.013	714	0.011	595						
			1160	0.3	0.01	904	49	0.008	723	0.007	603						
			870	0.2	0.007	910	51	0.006	728	0.005	607						
			600	0.2	0.005	915	53	0.004	732	0.003	610						
			300	0.1	0.002	925	56	0.002	740	0.001	617						
			100	–	0.001	926	56	0.001	741	0.001	617						
4100(D)	50	82	2500	0.6	0.015	595	39	0.012	476	0.010	397	100	650	1345	894	1440	
			1750	0.4	0.009	596	43	0.007	477	0.006	397						
			1160	0.3	0.006	597	46	0.005	478	0.004	398						
			870	0.2	0.004	598	49	0.003	478	0.003	399						
			600	0.1	0.003	599	51	0.002	479	0.002	399						
			300	0.1	0.001	599	54	0.001	479	0.001	399						
			100	–	0	600	55	0.000	480	0.000	400						
4920(D)	60	82	2500	0.5	0.013	595	36	0.010	476	0.009	397	115	650	1345	894	1440	
			1750	0.4	0.008	597	40	0.006	478	0.005	398						
			1160	0.2	0.005	598	44	0.004	478	0.003	399						
			870	0.2	0.004	598	47	0.003	478	0.003	399						
			600	0.1	0.002	599	49	0.002	479	0.001	399						
			300	0.1	0.001	599	52	0.001	479	0.001	399						
			100	–	0	600	52	0.000	480	0.000	400						
5940(D)	60	99	2500	0.4	0.01	480	32	0.008	384	0.007	320	115	650	1345	894	1440	
			1750	0.3	0.006	481	36	0.005	385	0.004	321						
			1160	0.2	0.004	482	40	0.003	386	0.003	321						
			870	0.2	0.003	483	42	0.002	386	0.002	322						
			600	0.1	0.002	483	44	0.002	386	0.001	322						
			300	0.1	0.001	483	48	0.001	386	0.001	322						
			100	–	0	484	48	0.000	387	0.000	323						

1. Exact ratio.
 2. If input speed is below 1160 RPM, please specify speed and mounting position to ensure proper lubrication.
 3. Overhung load given at a distance equal to one shaft diameter from the face of the output seal.
 4. Overhung load is based on maximum bore size. Use of smaller driven shaft diameter may limit OHL capacity.

5. Overhung loads are based on the output shaft and output bearing capacities only. Check Overhung Load Section for other considerations.
 6. Overhung load and thrust load ratings are computed independent of each other. For combined load applications, contact Winsmith.

Ratings



2D DRAWINGS & 3D MODELS
www.WINSMITH.com



DOUBLE REDUCTION

With Mobil Glygoyle 460 Lubricant



CENTER DISTANCE DOUBLE WORM HELICAL WORM		PRIMARY 1.750 2.060	SECONDARY 2.375 2.375	HORSEPOWER AND TORQUE RATINGS								OVERHUNG LOAD CAPACITIES (lb)			THRUST LOAD CAPACITIES (lb)		
OVERALL RATIO ¹	PRIMARY RATIO ¹	SECONDARY RATIO ¹	INPUT RPM ²	OUTPUT RPM	MECHANICAL								INPUT SHAFT ALL SHAFT INPUT MODELS	OUTPUT SHAFT ^{5,6}		OUTPUT SHAFT ⁶	
					1.00 SERVICE FACTOR			1.25 SERVICE FACTOR			1.50 SERVICE FACTOR			SOLID ³ SHAFT (e.g. MDND)	HOLLOW ⁴ SHAFT (e.g. MDSD)	SOLID SHAFT (e.g. MDND)	HOLLOW SHAFT (e.g. MDSD)
					INPUT HP	OUTPUT TORQUE (lb-in.)	EFF	INPUT HP	OUTPUT TORQUE (lb-in.)	INPUT HP	OUTPUT TORQUE (lb-in.)						
25.3(H)	5.07	5	2500	98.6	2.639	1613	96	2.111	1290	1.759	1075	250	748	1100	844	1643	
			1750	69.0	1.974	1718	95	1.579	1374	1.316	1145						
			1160	45.8	1.391	1812	95	1.113	1450	0.927	1208						
			870	34.3	1.083	1862	94	0.866	1490	0.722	1241						
			600	23.7	0.786	1911	91	0.629	1529	0.524	1274						
			300	11.8	0.416	1968	89	0.333	1574	0.277	1312						
			100	3.9	0.147	2008	86	0.118	1606	0.098	1339						
30.4(H)	6.08	5	2500	82.2	2.28	1670	96	1.824	1336	1.520	1113	250	748	1100	844	1643	
			1750	57.6	1.693	1763	95	1.354	1410	1.129	1175						
			1160	38.2	1.188	1845	94	0.950	1476	0.792	1230						
			870	28.6	0.925	1888	93	0.740	1510	0.617	1259						
			600	19.7	0.658	1929	92	0.526	1543	0.439	1286						
			300	9.9	0.346	1978	90	0.277	1582	0.231	1319						
			100	3.3	0.12	2012	88	0.096	1610	0.080	1341						
38.0(H)	5.07	7.5	2500	65.7	1.798	1640	95	1.438	1312	1.199	1093	250	799	1187	968	1909	
			1750	46.0	1.393	1812	95	1.114	1450	0.929	1208						
			1160	30.5	0.855	1658	94	0.684	1326	0.570	1105						
			870	22.9	0.675	1724	93	0.540	1379	0.450	1149						
			600	15.8	0.497	1787	90	0.398	1430	0.331	1191						
			300	7.9	0.247	1716	87	0.198	1373	0.165	1144						
			100	2.6	0.085	1739	85	0.068	1391	0.057	1159						
50(D)	10	5	2500	50.0	1.589	1794	90	1.271	1435	1.059	1196	159	748	1100	844	1643	
			1750	35.0	1.148	1859	90	0.918	1487	0.765	1239						
			1160	23.2	0.794	1913	89	0.635	1530	0.529	1275						
			870	17.4	0.607	1941	88	0.486	1553	0.405	1294						
			600	12.0	0.43	1967	87	0.344	1574	0.287	1311						
			300	6.0	0.224	1998	85	0.179	1598	0.149	1332						
			100	2.0	0.078	2018	82	0.062	1614	0.052	1345						
50.7(H)	5.07	10	2500	49.3	1.09	1307	94	0.872	1046	0.727	871	250	895	1280	1067	1909	
			1750	34.5	0.821	1404	94	0.657	1123	0.547	936						
			1160	22.9	0.542	1381	92	0.434	1105	0.361	921						
			870	17.2	0.42	1404	91	0.336	1123	0.280	936						
			600	11.8	0.306	1426	88	0.245	1141	0.204	951						
			300	5.9	0.159	1450	86	0.127	1160	0.106	967						
			100	2.0	0.055	1467	84	0.044	1174	0.037	978						
60.8(H)	6.08	10	2500	41.1	0.946	1360	94	0.757	1088	0.631	907	250	895	1280	1067	1909	
			1750	28.8	0.666	1358	93	0.533	1086	0.444	905						
			1160	19.1	0.461	1396	92	0.369	1117	0.307	931						
			870	14.3	0.359	1416	90	0.287	1133	0.239	944						
			600	9.9	0.254	1434	88	0.203	1147	0.169	956						
			300	4.9	0.133	1454	86	0.106	1163	0.089	969						
			100	1.6	0.045	1468	86	0.036	1174	0.030	979						

Ratings

1. Exact ratio.
 2. If input speed is below 1160 RPM, please specify speed and mounting position to ensure proper lubrication.
 3. Overhung load given at a distance equal to one shaft diameter from the face of the output seal.
 4. Overhung load is based on maximum bore size. Use of smaller driven shaft diameter may limit OHL capacity.

5. Overhung loads are based on the output shaft and output bearing capacities only. Check Overhung Load Section for other considerations.
 6. Overhung load and thrust load ratings are computed independent of each other. For combined load applications, contact Winsmith.





DOUBLE REDUCTION

With Mobil Glygoyle 460 Lubricant

REDUCER SIZE

E24

CENTER DISTANCE DOUBLE WORM HELICAL WORM		PRIMARY 1.750 2.060	SECONDARY 2.375 2.375	HORSEPOWER AND TORQUE RATINGS								OVERHUNG LOAD CAPACITIES (lb)			THRUST LOAD CAPACITIES (lb)	
OVERALL RATIO ¹	PRIMARY RATIO ¹	SECONDARY RATIO ¹	INPUT RPM ²	OUTPUT RPM	MECHANICAL						ALL SHAFT INPUT MODELS	INPUT SHAFT		OUTPUT SHAFT ^{5,6}		
					1.00 SERVICE FACTOR		1.25 SERVICE FACTOR		1.50 SERVICE FACTOR			SOLID ³ SHAFT (e.g. MDND)	HOLLOW ⁴ SHAFT (e.g. MDSD)	SOLID SHAFT (e.g. MDND)	HOLLOW SHAFT (e.g. MDSD)	
					INPUT HP	OUTPUT TORQUE (lb·in.)	EFF	INPUT HP	OUTPUT TORQUE (lb·in.)	INPUT HP	OUTPUT TORQUE (lb·in.)					
75(D)	5	15	2500	33.3	0.846	1395	87	0.677	1116	0.564	930	183	1025	1414	1238	1909
			1750	23.3	0.618	1476	88	0.494	1181	0.412	984					
			1160	15.5	0.413	1489	88	0.330	1191	0.275	993					
			870	11.6	0.319	1514	87	0.255	1211	0.213	1009					
			600	8.0	0.232	1537	84	0.186	1230	0.155	1025					
			300	4.0	0.123	1563	81	0.098	1250	0.082	1042					
			100	1.3	0.043	1581	78	0.034	1265	0.029	1054					
76.0(H)	5.07	15	2500	32.9	0.79	1398	92	0.632	1118	0.527	932	250	1025	1414	1238	1909
			1750	23.0	0.586	1479	92	0.469	1183	0.391	986					
			1160	15.3	0.397	1490	91	0.318	1192	0.265	993					
			870	11.4	0.308	1515	89	0.246	1212	0.205	1010					
			600	7.9	0.225	1537	85	0.180	1230	0.150	1025					
			300	3.9	0.119	1563	82	0.095	1250	0.079	1042					
			100	1.3	0.041	1581	81	0.033	1265	0.027	1054					
91.1(H)	6.08	15	2500	27.4	0.68	1442	92	0.544	1154	0.453	961	250	1025	1414	1238	1909
			1750	19.2	0.487	1466	92	0.390	1173	0.325	977					
			1160	12.7	0.338	1506	90	0.270	1205	0.225	1004					
			870	9.5	0.264	1527	88	0.211	1222	0.176	1018					
			600	6.6	0.187	1546	86	0.150	1237	0.125	1031					
			300	3.3	0.098	1568	83	0.078	1254	0.065	1045					
			100	1.1	0.033	1582	84	0.026	1266	0.022	1055					
100(D)	5	20	2500	25.0	0.659	1429	86	0.527	1143	0.439	953	183	1025	1414	1500	1909
			1750	17.5	0.49	1543	87	0.392	1234	0.327	1029					
			1160	11.6	0.311	1474	87	0.249	1179	0.207	983					
			870	8.7	0.242	1505	86	0.194	1204	0.161	1003					
			600	6.0	0.177	1534	82	0.142	1227	0.118	1023					
			300	3.0	0.092	1531	79	0.074	1225	0.061	1021					
			100	1.0	0.032	1547	77	0.026	1238	0.021	1031					
101.3(H)	5.07	20	2500	24.7	0.616	1434	91	0.493	1147	0.411	956	250	1025	1414	1500	1909
			1750	17.3	0.465	1547	91	0.372	1238	0.310	1031					
			1160	11.4	0.299	1476	90	0.239	1181	0.199	984					
			870	8.6	0.234	1506	88	0.187	1205	0.156	1004					
			600	5.9	0.172	1535	84	0.138	1228	0.115	1023					
			300	3.0	0.09	1531	80	0.072	1225	0.060	1021					
			100	1.0	0.03	1547	80	0.024	1238	0.020	1031					
121.5(H)	6.08	20	2500	20.6	0.535	1496	91	0.428	1197	0.357	997	250	1025	1414	1500	1909
			1750	14.4	0.365	1445	90	0.292	1156	0.243	963					
			1160	9.5	0.256	1496	89	0.205	1197	0.171	997					
			870	7.2	0.201	1522	86	0.161	1218	0.134	1015					
			600	4.9	0.14	1515	85	0.112	1212	0.093	1010					
			300	2.5	0.073	1535	82	0.058	1228	0.049	1023					
			100	0.8	0.025	1548	82	0.020	1238	0.017	1032					

Ratings

1. Exact ratio.
 2. If input speed is below 1160 RPM, please specify speed and mounting position to ensure proper lubrication.
 3. Overhung load given at a distance equal to one shaft diameter from the face of the output seal.
 4. Overhung load is based on maximum bore size. Use of smaller driven shaft diameter may limit OHL capacity.
 5. Overhung loads are based on the output shaft and output bearing capacities only. Check Overhung Load Section for other considerations.
 6. Overhung load and thrust load ratings are computed independent of each other. For combined load applications, contact Winsmith.

DOUBLE REDUCTION

With Mobil Glygoyle 460 Lubricant



CENTER DISTANCE		PRIMARY	SECONDARY	HORSEPOWER AND TORQUE RATINGS								OVERHUNG LOAD CAPACITIES (lb)			THRUST LOAD CAPACITIES (lb)	
DOUBLE WORM		1.750	2.375	MECHANICAL								INPUT SHAFT	OUTPUT SHAFT ^{5,6}		OUTPUT SHAFT ⁶	
HELICAL WORM		2.060	2.375	1.00 SERVICE FACTOR			1.25 SERVICE FACTOR			1.50 SERVICE FACTOR		ALL SHAFT INPUT MODELS	SOLID ³ SHAFT (e.g. MDND)	HOLLOW ⁴ SHAFT (e.g. MDSD)	SOLID SHAFT (e.g. MDND)	HOLLOW SHAFT (e.g. MDSD)
OVERALL RATIO ¹	PRIMARY RATIO ¹	SECONDARY RATIO ¹	INPUT RPM ²	OUTPUT RPM	INPUT HP	OUTPUT TORQUE (lb-in.)	EFF	INPUT HP	OUTPUT TORQUE (lb-in.)	INPUT HP	OUTPUT TORQUE (lb-in.)					
150(D)	10	15	2500	16.7	0.467	1481	84	0.374	1185	0.311	987	159	1025	1414	1238	1909
			1750	11.7	0.334	1513	84	0.267	1210	0.223	1009					
			1160	7.7	0.232	1538	81	0.186	1230	0.155	1025					
			870	5.8	0.178	1551	80	0.142	1241	0.119	1034					
			600	4.0	0.126	1563	79	0.101	1250	0.084	1042					
			300	2.0	0.065	1576	78	0.052	1261	0.043	1051					
			100	0.7	0.023	1585	74	0.018	1268	0.015	1057					
152.0(H)	5.07	30	2500	16.4	0.422	1421	88	0.338	1137	0.281	947	250	1025	1414	1500	1909
			1750	11.5	0.307	1480	88	0.246	1184	0.205	987					
			1160	7.6	0.213	1528	87	0.170	1222	0.142	1019					
			870	5.7	0.165	1552	85	0.132	1242	0.110	1035					
			600	3.9	0.121	1575	81	0.097	1260	0.081	1050					
			300	2.0	0.064	1601	78	0.051	1281	0.043	1067					
			100	0.7	0.022	1618	77	0.018	1294	0.015	1079					
182.3(H)	6.08	30	2500	13.7	0.359	1454	88	0.287	1163	0.239	969	250	1025	1414	1500	1909
			1750	9.6	0.261	1503	88	0.209	1202	0.174	1002					
			1160	6.4	0.181	1544	86	0.145	1235	0.121	1029					
			870	4.8	0.142	1564	84	0.114	1251	0.095	1043					
			600	3.3	0.1	1583	82	0.080	1266	0.067	1055					
			300	1.6	0.053	1605	79	0.042	1284	0.035	1070					
			100	0.5	0.018	1620	80	0.014	1296	0.012	1080					
200(D)	10	20	2500	12.5	0.352	1464	83	0.282	1171	0.235	976	159	1025	1414	1500	1909
			1750	8.8	0.253	1504	82	0.202	1203	0.169	1003					
			1160	5.8	0.178	1536	80	0.142	1229	0.119	1024					
			870	4.4	0.134	1520	78	0.107	1216	0.089	1013					
			600	3.0	0.095	1531	77	0.076	1225	0.063	1021					
			300	1.5	0.048	1543	76	0.038	1234	0.032	1029					
			100	0.5	0.017	1551	73	0.014	1241	0.011	1034					
202.6(H)	5.07	40	2500	12.3	0.313	1362	85	0.250	1090	0.209	908	250	1025	1414	1500	1909
			1750	8.6	0.227	1414	85	0.182	1131	0.151	943					
			1160	5.7	0.156	1457	85	0.125	1166	0.104	971					
			870	4.3	0.122	1478	83	0.098	1182	0.081	985					
			600	3.0	0.09	1498	79	0.072	1198	0.060	999					
			300	1.5	0.048	1521	75	0.038	1217	0.032	1014					
			100	0.5	0.016	1536	75	0.013	1229	0.011	1024					
253.3(H)	5.07	50	2500	9.9	0.262	1390	83	0.210	1112	0.175	927	250	1025	1414	1500	1909
			1750	6.9	0.194	1485	84	0.155	1188	0.129	990					
			1160	4.6	0.124	1402	82	0.099	1122	0.083	935					
			870	3.4	0.097	1441	81	0.078	1153	0.065	961					
			600	2.4	0.073	1478	76	0.058	1182	0.049	985					
			300	1.2	0.037	1435	73	0.030	1148	0.025	957					
			100	0.4	0.012	1448	74	0.010	1158	0.008	965					

1. Exact ratio.
 2. If input speed is below 1160 RPM, please specify speed and mounting position to ensure proper lubrication.
 3. Overhung load given at a distance equal to one shaft diameter from the face of the output seal.
 4. Overhung load is based on maximum bore size. Use of smaller driven shaft diameter may limit OHL capacity.

5. Overhung loads are based on the output shaft and output bearing capacities only. Check Overhung Load Section for other considerations.
 6. Overhung load and thrust load ratings are computed independent of each other. For combined load applications, contact Winsmith.

Ratings



DOUBLE REDUCTION

With Mobil Glygoyle 460 Lubricant

REDUCER SIZE

E24

CENTER DISTANCE DOUBLE WORM HELICAL WORM		PRIMARY 1.750 2.060	SECONDARY 2.375 2.375	HORSEPOWER AND TORQUE RATINGS								OVERHUNG LOAD CAPACITIES (lb)			THRUST LOAD CAPACITIES (lb)		
OVERALL RATIO ¹	PRIMARY RATIO ¹	SECONDARY RATIO ¹	INPUT RPM ²	OUTPUT RPM	MECHANICAL								ALL SHAFT INPUT MODELS	OUTPUT SHAFT ^{5,6}		OUTPUT SHAFT ⁶	
					1.00 SERVICE FACTOR			1.25 SERVICE FACTOR			1.50 SERVICE FACTOR			SOLID ³ SHAFT (e.g. MDND)	HOLLOW ⁴ SHAFT (e.g. MDSD)	SOLID SHAFT (e.g. MDND)	HOLLOW SHAFT (e.g. MDSD)
					INPUT HP	OUTPUT TORQUE (lbf-in.)	EFF	INPUT HP	OUTPUT TORQUE (lbf-in.)	INPUT HP	OUTPUT TORQUE (lbf-in.)						
300(D)	20	15	2500	8.3	0.272	1535	75	0.218	1228	0.181	1023	149	1025	1414	1238	1909	
			1750	5.8	0.19	1551	75	0.152	1241	0.127	1034						
			1160	3.9	0.128	1564	75	0.102	1251	0.085	1043						
			870	2.9	0.097	1570	75	0.078	1256	0.065	1047						
			600	2.0	0.066	1576	75	0.053	1261	0.044	1051						
			300	1.0	0.033	1583	76	0.026	1266	0.022	1055						
			100	0.3	0.012	1587	73	0.010	1270	0.008	1058						
303.8(H)	6.08	50	2500	8.2	0.225	1442	84	0.180	1154	0.150	961	250	1025	1414	1500	1909	
			1750	5.8	0.151	1363	83	0.121	1090	0.101	909						
			1160	3.8	0.106	1428	81	0.085	1142	0.071	952						
			870	2.9	0.084	1461	79	0.067	1169	0.056	974						
			600	2.0	0.058	1421	77	0.046	1137	0.039	947						
			300	1.0	0.03	1438	75	0.024	1150	0.020	959						
			100	0.3	0.01	1449	76	0.008	1159	0.007	966						
364.6(H)	6.08	60	2500	6.9	0.167	1221	79	0.134	977	0.111	814	250	1025	1414	1500	1909	
			1750	4.8	0.12	1256	80	0.096	1005	0.080	837						
			1160	3.2	0.083	1284	78	0.066	1027	0.055	856						
			870	2.4	0.065	1299	76	0.052	1039	0.043	866						
			600	1.6	0.046	1312	75	0.037	1050	0.031	875						
			300	0.8	0.024	1364	73	0.019	1091	0.016	909						
			100	0.3	0.009	1524	75	0.007	1219	0.006	1016						
500(D)	25	20	2500	5.0	0.176	1515	68	0.141	1212	0.117	1010	153	1025	1414	1500	1909	
			1750	3.5	0.124	1527	68	0.099	1222	0.083	1018						
			1160	2.3	0.082	1536	69	0.066	1229	0.055	1024						
			870	1.7	0.061	1541	69	0.049	1233	0.041	1027						
			600	1.2	0.042	1545	69	0.034	1236	0.028	1030						
			300	0.6	0.021	1550	70	0.017	1240	0.014	1033						
			100	0.2	0.007	1553	67	0.006	1242	0.005	1035						
750(D)	25	30	2500	3.3	0.127	1583	66	0.102	1266	0.085	1055	153	1025	1414	1500	1909	
			1750	2.3	0.09	1596	66	0.072	1277	0.060	1064						
			1160	1.5	0.061	1606	65	0.049	1285	0.041	1071						
			870	1.2	0.045	1611	66	0.036	1289	0.030	1074						
			600	0.8	0.031	1616	67	0.025	1293	0.021	1077						
			300	0.4	0.015	1621	68	0.012	1297	0.010	1081						
			100	0.1	0.005	1625	65	0.004	1300	0.003	1083						
1000(D)	50	20	2500	2.5	0.104	1535	58	0.083	1228	0.069	1023	171	1025	1414	1500	1909	
			1750	1.8	0.071	1541	61	0.057	1233	0.047	1027						
			1160	1.2	0.046	1545	62	0.037	1236	0.031	1030						
			870	0.9	0.034	1548	63	0.027	1238	0.023	1032						
			600	0.6	0.023	1550	64	0.018	1240	0.015	1033						
			300	0.3	0.011	1552	65	0.009	1242	0.007	1035						
			100	0.1	0.004	1554	63	0.003	1243	0.003	1036						

Ratings

1. Exact ratio.
 2. If input speed is below 1160 RPM, please specify speed and mounting position to ensure proper lubrication.
 3. Overhung load given at a distance equal to one shaft diameter from the face of the output seal.
 4. Overhung load is based on maximum bore size. Use of smaller driven shaft diameter may limit OHL capacity.

5. Overhung loads are based on the output shaft and output bearing capacities only. Check Overhung Load Section for other considerations.
 6. Overhung load and thrust load ratings are computed independent of each other. For combined load applications, contact Winsmith.



2D DRAWINGS & 3D MODELS
www.WINSMITH.com



DOUBLE REDUCTION

With Mobil Glygoyle 460 Lubricant



CENTER DISTANCE		PRIMARY	SECONDARY	HORSEPOWER AND TORQUE RATINGS								OVERHUNG LOAD CAPACITIES (lb)			THRUST LOAD CAPACITIES (lb)	
DOUBLE WORM		1.750	2.375	MECHANICAL								INPUT SHAFT	OUTPUT SHAFT ^{5,6}		OUTPUT SHAFT ⁶	
HELICAL WORM		2.060	2.375	1.00 SERVICE FACTOR			1.25 SERVICE FACTOR		1.50 SERVICE FACTOR			ALL SHAFT INPUT MODELS	SOLID ³ SHAFT (e.g. MDND)	HOLLOW ⁴ SHAFT (e.g. MDSD)	SOLID SHAFT (e.g. MDND)	HOLLOW SHAFT (e.g. MDSD)
OVERALL RATIO ¹	PRIMARY RATIO ¹	SECONDARY RATIO ¹	INPUT RPM ²	OUTPUT RPM	INPUT HP	OUTPUT TORQUE (lbf-in.)	EFF	INPUT HP	OUTPUT TORQUE (lbf-in.)	INPUT HP	OUTPUT TORQUE (lbf-in.)					
1500(D)	50	30	2500	1.7	0.075	1605	57	0.060	1284	0.050	1070	171	1025	1414	1500	1909
			1750	1.2	0.052	1611	57	0.042	1289	0.035	1074					
			1160	0.8	0.035	1617	57	0.028	1294	0.023	1078					
			870	0.6	0.026	1619	57	0.021	1295	0.017	1079					
			600	0.4	0.018	1621	58	0.014	1297	0.012	1081					
			300	0.2	0.009	1624	58	0.007	1299	0.006	1083					
			100	0.1	0.003	1626	56	0.002	1301	0.002	1084					
2000(D)	50	40	2500	1.3	0.057	1524	53	0.046	1219	0.038	1016	171	1025	1414	1500	1909
			1750	0.9	0.038	1530	56	0.030	1224	0.025	1020					
			1160	0.6	0.024	1535	58	0.019	1228	0.016	1023					
			870	0.4	0.018	1537	59	0.014	1230	0.012	1025					
			600	0.3	0.012	1539	60	0.010	1231	0.008	1026					
			300	0.2	0.006	1542	62	0.005	1234	0.004	1028					
			100	0.1	0.002	1543	59	0.002	1234	0.001	1029					
3000(D)	60	50	2500	0.8	0.041	1441	47	0.033	1153	0.027	961	202	1025	1414	1500	1909
			1750	0.6	0.028	1445	49	0.022	1156	0.019	963					
			1160	0.4	0.017	1448	51	0.014	1158	0.011	965					
			870	0.3	0.012	1450	54	0.010	1160	0.008	967					
			600	0.2	0.008	1452	56	0.006	1162	0.005	968					
			300	0.1	0.004	1453	58	0.003	1162	0.003	969					
			100	-	0.001	1454	56	0.001	1163	0.001	969					
3600(D)	60	60	2500	0.7	0.034	1408	45	0.027	1126	0.023	939	202	1025	1414	1500	1909
			1750	0.5	0.025	1508	47	0.020	1206	0.017	1005					
			1160	0.3	0.016	1523	50	0.013	1218	0.011	1015					
			870	0.2	0.011	1525	52	0.009	1220	0.007	1017					
			600	0.2	0.007	1527	54	0.006	1222	0.005	1018					
			300	0.1	0.004	1528	56	0.003	1222	0.003	1019					
			100	-	0.001	1530	55	0.001	1224	0.001	1020					
4150(D)	83	50	2500	0.6	0.039	1444	36	0.031	1155	0.026	963	202	1025	1414	1500	1909
			1750	0.4	0.025	1447	41	0.020	1158	0.017	965					
			1160	0.3	0.015	1450	45	0.012	1160	0.010	967					
			870	0.2	0.011	1451	47	0.009	1161	0.007	967					
			600	0.1	0.007	1452	49	0.006	1162	0.005	968					
			300	0.1	0.003	1454	53	0.002	1163	0.002	969					
			100	-	0.001	1455	51	0.001	1164	0.001	970					

1. Exact ratio.
 2. If input speed is below 1160 RPM, please specify speed and mounting position to ensure proper lubrication.
 3. Overhung load given at a distance equal to one shaft diameter from the face of the output seal.
 4. Overhung load is based on maximum bore size. Use of smaller driven shaft diameter may limit OHL capacity.

5. Overhung loads are based on the output shaft and output bearing capacities only. Check Overhung Load Section for other considerations.
 6. Overhung load and thrust load ratings are computed independent of each other. For combined load applications, contact WinSmith.

Ratings





DOUBLE REDUCTION

With Mobil Glygoyle 460 Lubricant

REDUCER SIZE

E24

CENTER DISTANCE		PRIMARY	SECONDARY	HORSEPOWER AND TORQUE RATINGS								OVERHUNG LOAD CAPACITIES (lb)			THRUST LOAD CAPACITIES (lb)	
DOUBLE WORM		1.750	2.375	MECHANICAL								INPUT SHAFT	OUTPUT SHAFT ^{5,6}		OUTPUT SHAFT ⁶	
HELICAL WORM		2.060	2.375	1.00 SERVICE FACTOR			1.25 SERVICE FACTOR			1.50 SERVICE FACTOR		ALL SHAFT INPUT MODELS	SOLID ³ SHAFT (e.g. MDND)	HOLLOW ⁴ SHAFT (e.g. MDSD)	SOLID SHAFT (e.g. MDND)	HOLLOW SHAFT (e.g. MDSD)
OVERALL RATIO ¹	PRIMARY RATIO ¹	SECONDARY RATIO ¹	INPUT RPM ²	OUTPUT RPM	INPUT HP	OUTPUT TORQUE (lbf-in.)	EFF	INPUT HP	OUTPUT TORQUE (lbf-in.)	INPUT HP	OUTPUT TORQUE (lbf-in.)					
5000(D)	100	50	2500	0.5	0.037	1446	31	0.030	1157	0.025	964	125	1025	1414	1500	1909
			1750	0.4	0.023	1449	35	0.018	1159	0.015	966					
			1160	0.2	0.014	1451	38	0.011	1161	0.009	967					
			870	0.2	0.01	1452	41	0.008	1162	0.007	968					
			600	0.1	0.006	1453	43	0.005	1162	0.004	969					
			300	0.1	0.003	1454	47	0.002	1163	0.002	969					
			100	-	0.001	1455	47	0.001	1164	0.001	970					
6000(D)	100	60	2500	0.4	0.033	1517	30	0.026	1214	0.022	1011	125	1025	1414	1500	1909
			1750	0.3	0.021	1524	34	0.017	1219	0.014	1016					
			1160	0.2	0.013	1526	37	0.010	1221	0.009	1017					
			870	0.1	0.009	1527	40	0.007	1222	0.006	1018					
			600	0.1	0.006	1528	42	0.005	1222	0.004	1019					
			300	0.1	0.003	1529	46	0.002	1223	0.002	1019					
			100	-	0.001	1530	46	0.001	1224	0.001	1020					
8000(D)	100	80	2500	0.3	0.018	988	27	0.014	790	0.012	659	125	1025	1414	1500	1909
			1750	0.2	0.011	988	31	0.009	790	0.007	659					
			1160	0.1	0.007	988	34	0.006	790	0.005	659					
			870	0.1	0.005	988	36	0.004	790	0.003	659					
			600	0.1	0.003	988	39	0.002	790	0.002	659					
			300	-	0.001	988	42	0.001	790	0.001	659					
			100	-	0	988	43	0.000	790	0.000	659					
10000(D)	100	100	2500	0.3	0.013	818	25	0.010	654	0.009	545	125	1025	1414	1500	1909
			1750	0.2	0.008	818	28	0.006	654	0.005	545					
			1160	0.1	0.005	818	31	0.004	654	0.003	545					
			870	0.1	0.003	818	33	0.002	654	0.002	545					
			600	0.1	0.002	818	35	0.002	654	0.001	545					
			300	-	0.001	818	38	0.001	654	0.001	545					
			100	-	0	818	39	0.000	654	0.000	545					

1. Exact ratio.
 2. If input speed is below 1160 RPM, please specify speed and mounting position to ensure proper lubrication.
 3. Overhung load given at a distance equal to one shaft diameter from the face of the output seal.
 4. Overhung load is based on maximum bore size. Use of smaller driven shaft diameter may limit OHL capacity.

5. Overhung loads are based on the output shaft and output bearing capacities only. Check Overhung Load Section for other considerations.
 6. Overhung load and thrust load ratings are computed independent of each other. For combined load applications, contact Winsmith.

Ratings



2D DRAWINGS & 3D MODELS
www.WINSMITH.com



DOUBLE REDUCTION

With Mobil Glygoyle 460 Lubricant



CENTER DISTANCE DOUBLE WORM HELICAL WORM		PRIMARY 1.750 2.060	SECONDARY 2.625 2.625	HORSEPOWER AND TORQUE RATINGS								OVERHUNG LOAD CAPACITIES (lb)			THRUST LOAD CAPACITIES (lb)		
OVERALL RATIO ¹	PRIMARY RATIO ¹	SECONDARY RATIO ¹	INPUT RPM ²	OUTPUT RPM	MECHANICAL								ALL SHAFT INPUT MODELS	OUTPUT SHAFT ^{5,6}		OUTPUT SHAFT ⁶	
					1.00 SERVICE FACTOR		1.25 SERVICE FACTOR		1.50 SERVICE FACTOR		SOLID ³ SHAFT (e.g. MDND)	HOLLOW ⁴ SHAFT (e.g. MDSD)		SOLID SHAFT (e.g. MDND)	HOLLOW SHAFT (e.g. MDSD)		
					INPUT HP	OUTPUT TORQUE (lb-ft-in.)	EFF	INPUT HP	OUTPUT TORQUE (lb-ft-in.)	INPUT HP						OUTPUT TORQUE (lb-ft-in.)	
25.3(H)	5.07	5	2500	98.6	3.447	2104	96	2.758	1683	2.298	1403	250	748	1302	844	1860	
			1750	69.0	2.61	2266	95	2.088	1813	1.740	1511						
			1160	45.8	1.865	2414	94	1.492	1931	1.243	1609						
			870	34.3	1.462	2487	93	1.170	1990	0.975	1658						
			600	23.7	1.071	2558	90	0.857	2046	0.714	1705						
			300	11.8	0.567	2643	88	0.454	2114	0.378	1762						
			100	3.9	0.197	2703	86	0.158	2162	0.131	1802						
30.4(H)	6.08	5	2500	82.2	3	2192	95	2.400	1754	2.000	1461	250	748	1302	844	1860	
			1750	57.6	2.26	2343	95	1.808	1874	1.507	1562						
			1160	38.2	1.599	2462	93	1.279	1970	1.066	1641						
			870	28.6	1.254	2525	91	1.003	2020	0.836	1683						
			600	19.7	0.896	2586	90	0.717	2069	0.597	1724						
			300	9.9	0.476	2658	88	0.381	2126	0.317	1772						
			100	3.3	0.165	2708	86	0.132	2166	0.110	1805						
38.0(H)	5.07	7.5	2500	65.7	2.631	2403	95	2.105	1922	1.754	1602	250	799	1405	968	2160	
			1750	46.0	1.999	2596	95	1.599	2077	1.333	1731						
			1160	30.5	1.29	2490	93	1.032	1992	0.860	1660						
			870	22.9	1.028	2601	92	0.822	2081	0.685	1734						
			600	15.8	0.767	2709	88	0.614	2167	0.511	1806						
			300	7.9	0.372	2581	87	0.298	2065	0.248	1721						
			100	2.6	0.129	2620	85	0.103	2096	0.086	1747						
50(D)	10	5	2500	50.0	1.833	2054	89	1.466	1643	1.222	1369	159	748	1302	844	1860	
			1750	35.0	1.491	2391	89	1.193	1913	0.994	1594						
			1160	23.2	1.083	2562	87	0.866	2050	0.722	1708						
			870	17.4	0.831	2603	86	0.665	2082	0.554	1735						
			600	12.0	0.585	2642	86	0.468	2114	0.390	1761						
			300	6.0	0.291	2607	85	0.233	2086	0.194	1738						
			100	2.0	0.102	2598	81	0.082	2078	0.068	1732						
50.7(H)	5.07	10	2500	49.3	1.512	1815	94	1.210	1452	1.008	1210	250	895	1535	1067	2160	
			1750	34.5	1.146	1954	93	0.917	1563	0.764	1303						
			1160	22.9	0.755	1906	92	0.604	1525	0.503	1271						
			870	17.2	0.593	1951	90	0.474	1561	0.395	1301						
			600	11.8	0.43	1994	87	0.344	1595	0.287	1329						
			300	5.9	0.217	1995	86	0.174	1596	0.145	1330						
			100	2.0	0.075	2019	84	0.060	1615	0.050	1346						
60.8(H)	6.08	10	2500	41.1	1.316	1891	94	1.053	1513	0.877	1261	250	895	1535	1067	2160	
			1750	28.8	0.917	1860	93	0.734	1488	0.611	1240						
			1160	19.1	0.648	1936	90	0.518	1549	0.432	1291						
			870	14.3	0.511	1974	88	0.409	1579	0.341	1316						
			600	9.9	0.355	1970	87	0.284	1576	0.237	1313						
			300	4.9	0.182	2001	86	0.146	1601	0.121	1334						
			100	1.6	0.063	2021	84	0.050	1617	0.042	1347						

1. Exact ratio.
 2. If input speed is below 1160 RPM, please specify speed and mounting position to ensure proper lubrication.
 3. Overhung load given at a distance equal to one shaft diameter from the face of the output seal.
 4. Overhung load is based on maximum bore size. Use of smaller driven shaft diameter may limit OHL capacity.

5. Overhung loads are based on the output shaft and output bearing capacities only. Check Overhung Load Section for other considerations.
 6. Overhung load and thrust load ratings are computed independent of each other. For combined load applications, contact Winsmith.

Ratings





DOUBLE REDUCTION

With Mobil Glygoyle 460 Lubricant

REDUCER SIZE

E26

CENTER DISTANCE DOUBLE WORM HELICAL WORM		PRIMARY 1.750 2.060	SECONDARY 2.625 2.625	HORSEPOWER AND TORQUE RATINGS								OVERHUNG LOAD CAPACITIES (lb)			THRUST LOAD CAPACITIES (lb)		
OVERALL RATIO ¹	PRIMARY RATIO ¹	SECONDARY RATIO ¹	INPUT RPM ²	OUTPUT RPM	MECHANICAL								ALL SHAFT INPUT MODELS	OUTPUT SHAFT ^{5,6}		OUTPUT SHAFT ⁶	
					1.00 SERVICE FACTOR			1.25 SERVICE FACTOR			1.50 SERVICE FACTOR			SOLID ³ SHAFT (e.g. MDND)	HOLLOW ⁴ SHAFT (e.g. MDSD)	SOLID SHAFT (e.g. MDND)	HOLLOW SHAFT (e.g. MDSD)
INPUT HP	OUTPUT TORQUE (lbf-in.)	EFF	INPUT HP	OUTPUT TORQUE (lbf-in.)	INPUT HP	OUTPUT TORQUE (lbf-in.)	INPUT HP	OUTPUT TORQUE (lbf-in.)	INPUT HP	OUTPUT TORQUE (lbf-in.)	INPUT HP	OUTPUT TORQUE (lbf-in.)					
75(D)	5	15	2500	33.3	1.141	1887	87	0.913	1510	0.761	1258	183	1025	1750	1238	2160	
			1750	23.3	0.831	1985	88	0.665	1588	0.554	1323						
			1160	15.5	0.569	2040	88	0.455	1632	0.379	1360						
			870	11.6	0.443	2076	86	0.354	1661	0.295	1384						
			600	8.0	0.326	2111	82	0.261	1689	0.217	1407						
			300	4.0	0.168	2150	81	0.134	1720	0.112	1433						
			100	1.3	0.06	2176	77	0.048	1741	0.040	1451						
76.0(H)	5.07	15	2500	32.9	1.065	1891	93	0.852	1513	0.710	1261	250	1025	1750	1238	2160	
			1750	23.0	0.789	1988	92	0.631	1590	0.526	1325						
			1160	15.3	0.547	2042	90	0.438	1634	0.365	1361						
			870	11.4	0.428	2078	88	0.342	1662	0.285	1385						
			600	7.9	0.316	2112	84	0.253	1690	0.211	1408						
			300	3.9	0.163	2150	83	0.130	1720	0.109	1433						
			100	1.3	0.057	2176	80	0.046	1741	0.038	1451						
91.1(H)	6.08	15	2500	27.4	0.915	1944	92	0.732	1555	0.610	1296	250	1025	1750	1238	2160	
			1750	19.2	0.668	2006	91	0.534	1605	0.445	1337						
			1160	12.7	0.468	2066	89	0.374	1653	0.312	1377						
			870	9.5	0.368	2096	86	0.294	1677	0.245	1397						
			600	6.6	0.263	2125	84	0.210	1700	0.175	1417						
			300	3.3	0.137	2157	82	0.110	1726	0.091	1438						
			100	1.1	0.075	3490	81	0.060	2792	0.050	2327						
100(D)	5	20	2500	25.0	0.855	1861	86	0.684	1489	0.570	1241	183	1025	1823	1500	2160	
			1750	17.5	0.617	1941	87	0.494	1553	0.411	1294						
			1160	11.6	0.425	2006	87	0.340	1605	0.283	1337						
			870	8.7	0.33	2039	85	0.264	1631	0.220	1359						
			600	6.0	0.243	2070	81	0.194	1656	0.162	1380						
			300	3.0	0.127	2105	79	0.102	1684	0.085	1403						
			100	1.0	0.045	2129	74	0.036	1703	0.030	1419						
101.3(H)	5.07	20	2500	24.7	0.798	1865	91	0.638	1492	0.532	1243	250	1025	1823	1500	2160	
			1750	17.3	0.585	1944	91	0.468	1555	0.390	1296						
			1160	11.4	0.408	2008	89	0.326	1606	0.272	1339						
			870	8.6	0.319	2040	87	0.255	1632	0.213	1360						
			600	5.9	0.237	2071	82	0.190	1657	0.158	1381						
			300	3.0	0.123	2106	80	0.098	1685	0.082	1404						
			100	1.0	0.043	2129	78	0.034	1703	0.029	1419						
121.5(H)	6.08	20	2500	20.6	0.682	1908	91	0.546	1526	0.455	1272	250	1025	1823	1500	2160	
			1750	14.4	0.499	1975	90	0.399	1580	0.333	1317						
			1160	9.5	0.349	2029	88	0.279	1623	0.233	1353						
			870	7.2	0.275	2057	85	0.220	1646	0.183	1371						
			600	4.9	0.196	2082	83	0.157	1666	0.131	1388						
			300	2.5	0.104	2111	80	0.083	1689	0.069	1407						
			100	0.8	0.035	2131	80	0.028	1705	0.023	1421						

1. Exact ratio.
 2. If input speed is below 1160 RPM, please specify speed and mounting position to ensure proper lubrication.
 3. Overhung load given at a distance equal to one shaft diameter from the face of the output seal.
 4. Overhung load is based on maximum bore size. Use of smaller driven shaft diameter may limit OHL capacity.

5. Overhung loads are based on the output shaft and output bearing capacities only. Check Overhung Load Section for other considerations.
 6. Overhung load and thrust load ratings are computed independent of each other. For combined load applications, contact Winsmith.

Ratings



2D DRAWINGS & 3D MODELS
www.WINSMITH.com



DOUBLE REDUCTION

With Mobil Glygoyle 460 Lubricant



CENTER DISTANCE DOUBLE WORM HELICAL WORM		PRIMARY 1.750 2.060	SECONDARY 2.625 2.625	HORSEPOWER AND TORQUE RATINGS								OVERHUNG LOAD CAPACITIES (lb)			THRUST LOAD CAPACITIES (lb)				
OVERALL RATIO ¹	PRIMARY RATIO ¹	SECONDARY RATIO ¹	INPUT RPM ²	OUTPUT RPM	MECHANICAL										ALL SHAFT INPUT MODELS	OUTPUT SHAFT ^{5,6}		OUTPUT SHAFT ⁶	
					1.00 SERVICE FACTOR			1.25 SERVICE FACTOR			1.50 SERVICE FACTOR					SOLID ³ SHAFT (e.g. MDND)	HOLLOW ⁴ SHAFT (e.g. MDSD)	SOLID SHAFT (e.g. MDND)	HOLLOW SHAFT (e.g. MDSD)
					INPUT HP	OUTPUT TORQUE (lb·in.)	EFF	INPUT HP	OUTPUT TORQUE (lb·in.)	INPUT HP	OUTPUT TORQUE (lb·in.)	INPUT HP	OUTPUT TORQUE (lb·in.)						
150(D)	10	15	2500	16.7	0.643	2029	84	0.514	1623	0.429	1353	159	1025	1750	1238	2160			
			1750	11.7	0.464	2076	83	0.371	1661	0.309	1384								
			1160	7.7	0.325	2113	80	0.260	1690	0.217	1409								
			870	5.8	0.247	2132	80	0.198	1706	0.165	1421								
			600	4.0	0.172	2150	79	0.138	1720	0.115	1433								
			300	2.0	0.088	2169	78	0.070	1735	0.059	1446								
			100	0.7	0.051	3490	73	0.041	2792	0.034	2327								
152.0(H)	5.07	30	2500	16.4	0.57	1941	89	0.456	1553	0.380	1294	250	1025	1823	1500	2160			
			1750	11.5	0.418	2028	89	0.334	1622	0.279	1352								
			1160	7.6	0.293	2099	87	0.234	1679	0.195	1399								
			870	5.7	0.229	2135	84	0.183	1708	0.153	1423								
			600	3.9	0.171	2169	79	0.137	1735	0.114	1446								
			300	2.0	0.093	2207	75	0.074	1766	0.062	1471								
			100	0.7	0.032	2233	73	0.026	1786	0.021	1489								
182.3(H)	6.08	30	2500	13.7	0.487	1989	89	0.390	1591	0.325	1326	250	1025	1823	1500	2160			
			1750	9.6	0.357	2063	88	0.286	1650	0.238	1375								
			1160	6.4	0.251	2123	86	0.201	1698	0.167	1415								
			870	4.8	0.198	2153	82	0.158	1722	0.132	1435								
			600	3.3	0.141	2182	81	0.113	1746	0.094	1455								
			300	1.6	0.076	2214	76	0.061	1771	0.051	1476								
			100	0.5	0.025	2235	76	0.020	1788	0.017	1490								
200(D)	10	20	2500	12.5	0.48	1996	83	0.384	1597	0.320	1331	159	1025	1823	1500	2160			
			1750	8.8	0.346	2038	82	0.277	1630	0.231	1359								
			1160	5.8	0.244	2072	78	0.195	1658	0.163	1381								
			870	4.4	0.186	2089	77	0.149	1671	0.124	1393								
			600	3.0	0.13	2105	77	0.104	1684	0.087	1403								
			300	1.5	0.067	2123	75	0.054	1698	0.045	1415								
			100	0.5	0.024	2135	70	0.019	1708	0.016	1423								
202.6(H)	5.07	40	2500	12.3	0.444	1975	87	0.355	1580	0.296	1317	250	1025	1823	1500	2160			
			1750	8.6	0.338	2142	87	0.270	1714	0.225	1428								
			1160	5.7	0.217	2021	85	0.174	1617	0.145	1347								
			870	4.3	0.172	2070	82	0.138	1656	0.115	1380								
			600	3.0	0.13	2117	77	0.104	1694	0.087	1411								
			300	1.5	0.068	2095	72	0.054	1676	0.045	1397								
			100	0.5	0.023	2118	71	0.018	1694	0.015	1412								
253.3(H)	5.07	50	2500	9.9	0.35	1890	85	0.280	1512	0.233	1260	250	1025	1823	1500	2160			
			1750	6.9	0.263	2035	85	0.210	1628	0.175	1357								
			1160	4.6	0.168	1910	82	0.134	1528	0.112	1273								
			870	3.4	0.134	1965	80	0.107	1572	0.089	1310								
			600	2.4	0.102	2018	74	0.082	1614	0.068	1345								
			300	1.2	0.053	1960	69	0.042	1568	0.035	1307								
			100	0.4	0.018	1980	69	0.014	1584	0.012	1320								

Ratings

1. Exact ratio.
 2. If input speed is below 1160 RPM, please specify speed and mounting position to ensure proper lubrication.
 3. Overhung load given at a distance equal to one shaft diameter from the face of the output seal.
 4. Overhung load is based on maximum bore size. Use of smaller driven shaft diameter may limit OHL capacity.

5. Overhung loads are based on the output shaft and output bearing capacities only. Check Overhung Load Section for other considerations.
 6. Overhung load and thrust load ratings are computed independent of each other. For combined load applications, contact Winsmith.





DOUBLE REDUCTION

With Mobil Glygoyle 460 Lubricant

REDUCER SIZE

E26

CENTER DISTANCE DOUBLE WORM HELICAL WORM		PRIMARY 1.750 2.060	SECONDARY 2.625 2.625	HORSEPOWER AND TORQUE RATINGS								OVERHUNG LOAD CAPACITIES (lb)			THRUST LOAD CAPACITIES (lb)		
OVERALL RATIO ¹	PRIMARY RATIO ¹	SECONDARY RATIO ¹	INPUT RPM ²	OUTPUT RPM	MECHANICAL								ALL SHAFT INPUT MODELS	OUTPUT SHAFT ^{5,6}		OUTPUT SHAFT ⁶	
					1.00 SERVICE FACTOR			1.25 SERVICE FACTOR			1.50 SERVICE FACTOR			SOLID ³ SHAFT (e.g. MDND)	HOLLOW ⁴ SHAFT (e.g. MDSD)	SOLID SHAFT (e.g. MDND)	HOLLOW SHAFT (e.g. MDSD)
			INPUT HP	OUTPUT TORQUE (lbf-in.)	EFF	INPUT HP	OUTPUT TORQUE (lbf-in.)	INPUT HP	OUTPUT TORQUE (lbf-in.)	INPUT HP	OUTPUT TORQUE (lbf-in.)						
300(D)	20	15	2500	8.3	0.382	2108	73	0.306	1686	0.255	1405	149	1025	1750	1238	2160	
			1750	5.8	0.266	2132	74	0.213	1706	0.177	1421						
			1160	3.9	0.176	2151	75	0.141	1721	0.117	1434						
			870	2.9	0.132	2160	75	0.106	1728	0.088	1440						
			600	2.0	0.092	2169	75	0.074	1735	0.061	1446						
			300	1.0	0.075	3490	74	0.060	2792	0.050	2327						
			100	0.3	0.026	3490	70	0.021	2792	0.017	2327						
303.8(H)	6.08	50	2500	8.2	0.303	1969	85	0.242	1575	0.202	1313	250	1025	1823	1500	2160	
			1750	5.8	0.203	1853	83	0.162	1482	0.135	1235						
			1160	3.8	0.146	1946	81	0.117	1557	0.097	1297						
			870	2.9	0.117	1993	78	0.094	1594	0.078	1329						
			600	2.0	0.081	1940	76	0.065	1552	0.054	1293						
			300	1.0	0.043	1965	72	0.034	1572	0.029	1310						
			100	0.3	0.014	1982	73	0.011	1586	0.009	1321						
364.6(H)	6.08	60	2500	6.9	0.223	1663	81	0.178	1330	0.149	1109	250	1025	1823	1500	2160	
			1750	4.8	0.162	1715	81	0.130	1372	0.108	1143						
			1160	3.2	0.113	1757	78	0.090	1406	0.075	1171						
			870	2.4	0.09	1778	75	0.072	1422	0.060	1185						
			600	1.6	0.064	1797	73	0.051	1438	0.043	1198						
			300	0.8	0.035	1856	70	0.028	1485	0.023	1237						
			100	0.3	0.013	2082	71	0.010	1666	0.009	1388						
500(D)	25	20	2500	5.0	0.242	2082	68	0.194	1666	0.161	1388	153	1025	1823	1500	2160	
			1750	3.5	0.169	2099	69	0.135	1679	0.113	1399						
			1160	2.3	0.112	2113	70	0.090	1690	0.075	1409						
			870	1.7	0.084	2120	70	0.067	1696	0.056	1413						
			600	1.2	0.058	2126	70	0.046	1701	0.039	1417						
			300	0.6	0.029	2133	70	0.023	1706	0.019	1422						
			100	0.2	0.01	2138	66	0.008	1710	0.007	1425						
750(D)	25	30	2500	3.3	0.181	2181	64	0.145	1745	0.121	1454	153	1025	1823	1500	2160	
			1750	2.3	0.128	2200	64	0.102	1760	0.085	1467						
			1160	1.5	0.085	2216	64	0.068	1773	0.057	1477						
			870	1.2	0.064	2223	64	0.051	1778	0.043	1482						
			600	0.8	0.044	2230	64	0.035	1784	0.029	1487						
			300	0.4	0.022	2238	64	0.018	1790	0.015	1492						
			100	0.1	0.008	2244	61	0.006	1795	0.005	1496						
1000(D)	50	20	2500	2.5	0.142	2111	59	0.114	1689	0.095	1407	171	1025	1823	1500	2160	
			1750	1.8	0.096	2120	61	0.077	1696	0.064	1413						
			1160	1.2	0.063	2127	62	0.050	1702	0.042	1418						
			870	0.9	0.047	2130	63	0.038	1704	0.031	1420						
			600	0.6	0.032	2133	63	0.026	1706	0.021	1422						
			300	0.3	0.016	2137	64	0.013	1710	0.011	1425						
			100	0.1	0.006	2139	61	0.005	1711	0.004	1426						

1. Exact ratio.
 2. If input speed is below 1160 RPM, please specify speed and mounting position to ensure proper lubrication.
 3. Overhung load given at a distance equal to one shaft diameter from the face of the output seal.
 4. Overhung load is based on maximum bore size. Use of smaller driven shaft diameter may limit OHL capacity.

5. Overhung loads are based on the output shaft and output bearing capacities only. Check Overhung Load Section for other considerations.
 6. Overhung load and thrust load ratings are computed independent of each other. For combined load applications, contact Winsmith.

Ratings



2D DRAWINGS & 3D MODELS
www.WINSMITH.com



DOUBLE REDUCTION

With Mobil Glygoyle 460 Lubricant



CENTER DISTANCE DOUBLE WORM HELICAL WORM		PRIMARY 1.750 2.060	SECONDARY 2.625 2.625	HORSEPOWER AND TORQUE RATINGS								OVERHUNG LOAD CAPACITIES (lb)			THRUST LOAD CAPACITIES (lb)		
OVERALL RATIO ¹	PRIMARY RATIO ¹	SECONDARY RATIO ¹	INPUT RPM ²	OUTPUT RPM	MECHANICAL								ALL SHAFT INPUT MODELS	OUTPUT SHAFT ^{5,6}		OUTPUT SHAFT ⁶	
					1.00 SERVICE FACTOR		1.25 SERVICE FACTOR		1.50 SERVICE FACTOR		SOLID ³ SHAFT (e.g. MDND)	HOLLOW ⁴ SHAFT (e.g. MDSD)		SOLID SHAFT (e.g. MDND)	HOLLOW SHAFT (e.g. MDSD)		
					INPUT HP	OUTPUT TORQUE (lb·in.)	EFF	INPUT HP	OUTPUT TORQUE (lb·in.)	INPUT HP						OUTPUT TORQUE (lb·in.)	
1500(D)	50	30	2500	1.7	0.104	2213	56	0.083	1770	0.069	1475	171	1025	1823	1500	2160	
			1750	1.2	0.074	2223	56	0.059	1778	0.049	1482						
			1160	0.8	0.05	2231	54	0.040	1785	0.033	1487						
			870	0.6	0.038	2235	54	0.030	1788	0.025	1490						
			600	0.4	0.026	2238	55	0.021	1790	0.017	1492						
			300	0.2	0.013	2242	54	0.010	1794	0.009	1495						
			100	0.1	0.004	2245	53	0.003	1796	0.003	1497						
2000(D)	50	40	2500	1.3	0.08	2100	52	0.064	1680	0.053	1400	171	1025	1823	1500	2160	
			1750	0.9	0.054	2109	54	0.043	1687	0.036	1406						
			1160	0.6	0.036	2116	55	0.029	1693	0.024	1411						
			870	0.4	0.026	2119	55	0.021	1695	0.017	1413						
			600	0.3	0.018	2122	56	0.014	1698	0.012	1415						
			300	0.2	0.009	2126	58	0.007	1701	0.006	1417						
			100	0.1	0.003	2128	55	0.002	1702	0.002	1419						
3000(D)	60	50	2500	0.8	0.058	1969	45	0.046	1575	0.039	1313	202	1025	1823	1500	2160	
			1750	0.6	0.04	1976	46	0.032	1581	0.027	1317						
			1160	0.4	0.025	1981	48	0.020	1585	0.017	1321						
			870	0.3	0.018	1983	50	0.014	1586	0.012	1322						
			600	0.2	0.012	1985	52	0.010	1588	0.008	1323						
			300	0.1	0.006	1988	54	0.005	1590	0.004	1325						
			100	-	0.002	1990	52	0.002	1592	0.001	1327						
3600(D)	60	60	2500	0.7	0.049	1917	43	0.039	1534	0.033	1278	202	1025	1823	1500	2160	
			1750	0.5	0.036	2054	44	0.029	1643	0.024	1369						
			1160	0.3	0.023	2070	47	0.018	1656	0.015	1380						
			870	0.2	0.016	2083	49	0.013	1666	0.011	1389						
			600	0.2	0.011	2096	51	0.009	1677	0.007	1397						
			300	0.1	0.005	2110	52	0.004	1688	0.003	1407						
			100	-	0.002	2112	51	0.002	1690	0.001	1408						
4150(D)	83	50	2500	0.6	0.057	1974	34	0.046	1579	0.038	1316	200	1025	1823	1500	2160	
			1750	0.4	0.036	1979	38	0.029	1583	0.024	1319						
			1160	0.3	0.022	1983	42	0.018	1586	0.015	1322						
			870	0.2	0.016	1985	44	0.013	1588	0.011	1323						
			600	0.1	0.01	1987	46	0.008	1590	0.007	1325						
			300	0.1	0.005	1989	49	0.004	1591	0.003	1326						
			100	-	0.002	1990	47	0.002	1592	0.001	1327						

1. Exact ratio.
 2. If input speed is below 1160 RPM, please specify speed and mounting position to ensure proper lubrication.
 3. Overhung load given at a distance equal to one shaft diameter from the face of the output seal.
 4. Overhung load is based on maximum bore size. Use of smaller driven shaft diameter may limit OHL capacity.

5. Overhung loads are based on the output shaft and output bearing capacities only. Check Overhung Load Section for other considerations.
 6. Overhung load and thrust load ratings are computed independent of each other. For combined load applications, contact Winsmith.

Ratings





DOUBLE REDUCTION

With Mobil Glygoyle 460 Lubricant

REDUCER SIZE

E26

CENTER DISTANCE		PRIMARY	SECONDARY	HORSEPOWER AND TORQUE RATINGS								OVERHUNG LOAD CAPACITIES (lb)			THRUST LOAD CAPACITIES (lb)	
DOUBLE WORM		1.750	2.625	MECHANICAL								INPUT SHAFT	OUTPUT SHAFT ^{5,6}		OUTPUT SHAFT ⁶	
HELICAL WORM		2.060	2.625	1.00 SERVICE FACTOR			1.25 SERVICE FACTOR			1.50 SERVICE FACTOR		ALL SHAFT INPUT MODELS	SOLID ³ SHAFT (e.g. MDND)	HOLLOW ⁴ SHAFT (e.g. MDSD)	SOLID SHAFT (e.g. MDND)	HOLLOW SHAFT (e.g. MDSD)
OVERALL RATIO ¹	PRIMARY RATIO ¹	SECONDARY RATIO ¹	INPUT RPM ²	OUTPUT RPM	INPUT HP	OUTPUT TORQUE (lbf-in.)	EFF	INPUT HP	OUTPUT TORQUE (lbf-in.)	INPUT HP	OUTPUT TORQUE (lbf-in.)					
5000(D)	100	50	2500	0.5	0.054	1978	29	0.043	1582	0.036	1319	125	1025	1823	1500	2160
			1750	0.4	0.034	1982	32	0.027	1586	0.023	1321					
			1160	0.2	0.02	1985	36	0.016	1588	0.013	1323					
			870	0.2	0.014	1986	38	0.011	1589	0.009	1324					
			600	0.1	0.009	1987	40	0.007	1590	0.006	1325					
			300	0.1	0.004	1989	44	0.003	1591	0.003	1326					
			100	-	0.001	1990	44	0.001	1592	0.001	1327					
6000(D)	100	60	2500	0.4	0.048	2056	28	0.038	1645	0.032	1371	125	1025	1823	1500	2160
			1750	0.3	0.031	2081	31	0.025	1665	0.021	1387					
			1160	0.2	0.018	2095	35	0.014	1676	0.012	1397					
			870	0.1	0.013	2097	37	0.010	1678	0.009	1398					
			600	0.1	0.008	2099	39	0.006	1679	0.005	1399					
			300	0.1	0.004	2111	43	0.003	1689	0.003	1407					
			100	-	0.001	2112	43	0.001	1690	0.001	1408					
8000(D)	100	80	2500	0.3	0.026	1395	26	0.021	1116	0.017	930	125	1025	1823	1500	2160
			1750	0.2	0.017	1395	29	0.014	1116	0.011	930					
			1160	0.1	0.01	1395	32	0.008	1116	0.007	930					
			870	0.1	0.007	1395	34	0.006	1116	0.005	930					
			600	0.1	0.005	1395	36	0.004	1116	0.003	930					
			300	-	0.002	1395	40	0.002	1116	0.001	930					
			100	-	0.001	1395	40	0.001	1116	0.001	930					
10000(D)	100	100	2500	0.3	0.018	1143	25	0.014	914	0.012	762	125	1025	1823	1500	2160
			1750	0.2	0.011	1145	28	0.009	916	0.007	763					
			1160	0.1	0.007	1147	30	0.006	918	0.005	765					
			870	0.1	0.005	1148	32	0.004	918	0.003	765					
			600	0.1	0.003	1148	34	0.002	918	0.002	765					
			300	-	0.001	1149	37	0.001	919	0.001	766					
			100	-	0.001	1150	36	0.001	920	0.001	767					

1. Exact ratio.
 2. If input speed is below 1160 RPM, please specify speed and mounting position to ensure proper lubrication.
 3. Overhung load given at a distance equal to one shaft diameter from the face of the output seal.
 4. Overhung load is based on maximum bore size. Use of smaller driven shaft diameter may limit OHL capacity.

5. Overhung loads are based on the output shaft and output bearing capacities only. Check Overhung Load Section for other considerations.
 6. Overhung load and thrust load ratings are computed independent of each other. For combined load applications, contact Winsmith.

Ratings



2D DRAWINGS & 3D MODELS
www.WINSMITH.com



DOUBLE REDUCTION

With Mobil Glygoyle 460 Lubricant



CENTER DISTANCE DOUBLE WORM HELICAL WORM		PRIMARY 2.000 2.060	SECONDARY 3.000 3.000	HORSEPOWER AND TORQUE RATINGS								OVERHUNG LOAD CAPACITIES (lb)			THRUST LOAD CAPACITIES (lb)		
OVERALL RATIO ¹	PRIMARY RATIO ¹	SECONDARY RATIO ¹	INPUT RPM ²	OUTPUT RPM	MECHANICAL								ALL SHAFT INPUT MODELS	OUTPUT SHAFT ^{5,6}		OUTPUT SHAFT ⁶	
					1.00 SERVICE FACTOR			1.25 SERVICE FACTOR			1.50 SERVICE FACTOR			SOLID ³ SHAFT (e.g. MDND)	HOLLOW ⁴ SHAFT (e.g. MDSD)	SOLID SHAFT (e.g. MDND)	HOLLOW SHAFT (e.g. MDSD)
					INPUT HP	OUTPUT TORQUE (lbf-in.)	EFF	INPUT HP	OUTPUT TORQUE (lbf-in.)	INPUT HP	OUTPUT TORQUE (lbf-in.)						
25.3(H)	5.07	5	2500	98.6	4.086	2473	95	3.269	1978	2.724	1649	250	1116	1175	1137	1856	
			1750	69.0	3.206	2751	94	2.565	2201	2.137	1834						
			1160	45.8	2.208	2805	92	1.766	2244	1.472	1870						
			870	34.3	1.698	2815	90	1.358	2252	1.132	1877						
			600	23.7	1.166	2765	89	0.933	2212	0.777	1843						
			300	11.8	0.612	2859	88	0.490	2287	0.408	1906						
			100	3.9	0.216	2978	86	0.173	2382	0.144	1985						
30.4(H)	6.08	5	2500	82.2	3.534	2556	94	2.827	2045	2.356	1704	250	1116	1175	1137	1856	
			1750	57.6	2.656	2713	93	2.125	2170	1.771	1809						
			1160	38.2	1.831	2755	91	1.465	2204	1.221	1837						
			870	28.6	1.39	2737	89	1.112	2190	0.927	1825						
			600	19.7	0.983	2784	89	0.786	2227	0.655	1856						
			300	9.9	0.499	2787	88	0.399	2230	0.333	1858						
			100	3.3	0.17	2800	86	0.136	2240	0.113	1867						
38.0(H)	5.07	7.5	2500	65.7	4.116	3745	95	3.293	2996	2.744	2497	250	1190	1260	1301	2146	
			1750	46.0	3.103	3993	94	2.482	3194	2.069	2662						
			1160	30.5	2.208	4196	92	1.766	3357	1.472	2797						
			870	22.9	1.693	4180	90	1.354	3344	1.129	2787						
			600	15.8	1.158	4076	88	0.926	3261	0.772	2717						
			300	7.9	0.583	4049	87	0.466	3239	0.389	2699						
			100	2.6	0.199	4067	85	0.159	3254	0.133	2711						
50(D)	5	10	2500	50.0	2.479	2790	89	1.983	2232	1.653	1860	303	1298	1368	1434	2365	
			1750	35.0	1.873	3017	89	1.498	2414	1.249	2011						
			1160	23.2	1.267	3022	88	1.014	2418	0.845	2015						
			870	17.4	0.986	3086	86	0.789	2469	0.657	2057						
			600	12.0	0.696	3147	86	0.557	2518	0.464	2098						
			300	6.0	0.36	3216	85	0.288	2573	0.240	2144						
			100	2.0	0.129	3262	80	0.103	2610	0.086	2175						
50.7(H)	5.07	10	2500	49.3	2.341	2800	94	1.873	2240	1.561	1867	250	1298	1368	1434	2365	
			1750	34.5	1.792	3024	93	1.434	2419	1.195	2016						
			1160	22.9	1.223	3026	90	0.978	2421	0.815	2017						
			870	17.2	0.955	3089	88	0.764	2471	0.637	2059						
			600	11.8	0.677	3149	87	0.542	2519	0.451	2099						
			300	5.9	0.35	3216	86	0.280	2573	0.233	2144						
			100	2.0	0.121	3263	84	0.097	2610	0.081	2175						
60.8(H)	6.08	10	2500	41.1	2.048	2922	93	1.638	2338	1.365	1948	250	1298	1368	1434	2365	
			1750	28.8	1.479	2962	92	1.183	2370	0.986	1975						
			1160	19.1	1.052	3067	88	0.842	2454	0.701	2045						
			870	14.3	0.808	3121	88	0.646	2497	0.539	2081						
			600	9.9	0.57	3171	87	0.456	2537	0.380	2114						
			300	4.9	0.294	3228	86	0.235	2582	0.196	2152						
			100	1.6	0.101	3266	84	0.081	2613	0.067	2177						

1. Exact ratio.
 2. If input speed is below 1160 RPM, please specify speed and mounting position to ensure proper lubrication.
 3. Overhung load given at a distance equal to one shaft diameter from the face of the output seal.
 4. Overhung load is based on maximum bore size. Use of smaller driven shaft diameter may limit OHL capacity.

5. Overhung loads are based on the output shaft and output bearing capacities only. Check Overhung Load Section for other considerations.
 6. Overhung load and thrust load ratings are computed independent of each other. For combined load applications, contact Winsmith.

Ratings





DOUBLE REDUCTION

With Mobil Glygoyle 460 Lubricant

REDUCER SIZE
E30

CENTER DISTANCE DOUBLE WORM HELICAL WORM		PRIMARY 2.000 2.060	SECONDARY 3.000 3.000	HORSEPOWER AND TORQUE RATINGS								OVERHUNG LOAD CAPACITIES (lb)			THRUST LOAD CAPACITIES (lb)		
OVERALL RATIO ¹	PRIMARY RATIO ¹	SECONDARY RATIO ¹	INPUT RPM ²	OUTPUT RPM	MECHANICAL								ALL SHAFT INPUT MODELS	OUTPUT SHAFT ^{5,6}		OUTPUT SHAFT ⁶	
					1.00 SERVICE FACTOR			1.25 SERVICE FACTOR			1.50 SERVICE FACTOR			SOLID ³ SHAFT (e.g. MDND)	HOLLOW ⁴ SHAFT (e.g. MDSD)	SOLID SHAFT (e.g. MDND)	HOLLOW SHAFT (e.g. MDSD)
					INPUT HP	OUTPUT TORQUE (lbf-in.)	EFF	INPUT HP	OUTPUT TORQUE (lbf-in.)	INPUT HP	OUTPUT TORQUE (lbf-in.)						
75(D)	5	15	2500	33.3	1.768	2952	88	1.414	2362	1.179	1968	303	1350	1583	1724	2711	
			1750	23.3	1.301	3111	88	1.041	2489	0.867	2074						
			1160	15.5	0.916	3241	87	0.733	2593	0.611	2161						
			870	11.6	0.722	3308	84	0.578	2646	0.481	2205						
			600	8.0	0.516	3371	83	0.413	2697	0.344	2247						
			300	4.0	0.268	3442	82	0.214	2754	0.179	2295						
			100	1.3	0.097	3490	76	0.078	2792	0.065	2327						
76.0(H)	5.07	15	2500	32.9	1.667	2960	93	1.334	2368	1.111	1973	250	1350	1583	1724	2711	
			1750	23.0	1.244	3116	92	0.995	2493	0.829	2077						
			1160	15.3	0.884	3245	89	0.707	2596	0.589	2163						
			870	11.4	0.7	3310	86	0.560	2648	0.467	2207						
			600	7.9	0.503	3372	84	0.402	2698	0.335	2248						
			300	3.9	0.261	3443	83	0.209	2754	0.174	2295						
			100	1.3	0.091	3490	81	0.073	2792	0.061	2327						
91.1(H)	6.08	15	2500	27.4	1.438	3045	92	1.150	2436	0.959	2030	250	1350	1583	1724	2711	
			1750	19.2	1.069	3179	91	0.855	2543	0.713	2119						
			1160	12.7	0.762	3288	87	0.610	2630	0.508	2192						
			870	9.5	0.599	3343	84	0.479	2674	0.399	2229						
			600	6.6	0.424	3396	84	0.339	2717	0.283	2264						
			300	3.3	0.219	3455	82	0.175	2764	0.146	2303						
			100	1.1	0.076	3490	80	0.061	2792	0.051	2327						
100(D)	5	20	2500	25.0	1.328	2923	87	1.062	2338	0.885	1949	303	1350	1750	1966	2800	
			1750	17.5	0.974	3067	87	0.779	2454	0.649	2045						
			1160	11.6	0.685	3185	86	0.548	2548	0.457	2123						
			870	8.7	0.54	3244	83	0.432	2595	0.360	2163						
			600	6.0	0.39	3301	81	0.312	2641	0.260	2201						
			300	3.0	0.202	3365	79	0.162	2692	0.135	2243						
			100	1.0	0.073	3408	74	0.058	2726	0.049	2272						
101.3(H)	5.07	20	2500	24.7	1.252	2929	92	1.002	2343	0.835	1953	250	1350	1750	1966	2800	
			1750	17.3	0.931	3071	90	0.745	2457	0.621	2047						
			1160	11.4	0.661	3188	88	0.529	2550	0.441	2125						
			870	8.6	0.525	3247	84	0.420	2598	0.350	2165						
			600	5.9	0.379	3303	82	0.303	2642	0.253	2202						
			300	3.0	0.197	3366	80	0.158	2693	0.131	2244						
			100	1.0	0.068	3409	78	0.054	2727	0.045	2273						
121.5(H)	6.08	20	2500	20.6	1.077	3007	91	0.862	2406	0.718	2005	250	1350	1750	1966	2800	
			1750	14.4	0.799	3128	89	0.639	2502	0.533	2085						
			1160	9.5	0.57	3227	86	0.456	2582	0.380	2151						
			870	7.2	0.452	3277	82	0.362	2622	0.301	2185						
			600	4.9	0.32	3323	81	0.256	2658	0.213	2215						
			300	2.5	0.165	3376	80	0.132	2701	0.110	2251						
			100	0.8	0.057	3412	78	0.046	2730	0.038	2275						

Ratings

1. Exact ratio.
 2. If input speed is below 1160 RPM, please specify speed and mounting position to ensure proper lubrication.
 3. Overhung load given at a distance equal to one shaft diameter from the face of the output seal.
 4. Overhung load is based on maximum bore size. Use of smaller driven shaft diameter may limit OHL capacity.
 5. Overhung loads are based on the output shaft and output bearing capacities only. Check Overhung Load Section for other considerations.
 6. Overhung load and thrust load ratings are computed independent of each other. For combined load applications, contact Winsmith.

DOUBLE REDUCTION

With Mobil Glygoyle 460 Lubricant



CENTER DISTANCE DOUBLE WORM HELICAL WORM		PRIMARY 2.000 2.060	SECONDARY 3.000 3.000	HORSEPOWER AND TORQUE RATINGS								OVERHUNG LOAD CAPACITIES (lb)			THRUST LOAD CAPACITIES (lb)		
OVERALL RATIO ¹	PRIMARY RATIO ¹	SECONDARY RATIO ¹	INPUT RPM ²	OUTPUT RPM	MECHANICAL								ALL SHAFT INPUT MODELS	OUTPUT SHAFT ^{5,6}		OUTPUT SHAFT ⁶	
					1.00 SERVICE FACTOR		1.25 SERVICE FACTOR		1.50 SERVICE FACTOR		SOLID ³ SHAFT (e.g. MDND)	HOLLOW ⁴ SHAFT (e.g. MDSD)		SOLID SHAFT (e.g. MDND)	HOLLOW SHAFT (e.g. MDSD)		
					INPUT HP	OUTPUT TORQUE (lbf-in.)	EFF	INPUT HP	OUTPUT TORQUE (lbf-in.)	INPUT HP						OUTPUT TORQUE (lbf-in.)	
150(D)	10	15	2500	16.7	1.019	3221	84	0.815	2577	0.679	2147	219	1350	1583	1724	2711	
			1750	11.7	0.75	3307	82	0.600	2646	0.500	2205						
			1160	7.7	0.513	3375	81	0.410	2700	0.342	2250						
			870	5.8	0.39	3409	80	0.312	2727	0.260	2273						
			600	4.0	0.274	3442	80	0.219	2754	0.183	2295						
			300	2.0	0.141	3478	78	0.113	2782	0.094	2319						
			100	0.7	0.051	3490	72	0.041	2792	0.034	2327						
152.0(H)	5.07	30	2500	16.4	0.889	3044	89	0.711	2435	0.593	2029	250	1350	2020	2400	2800	
			1750	11.5	0.663	3201	88	0.530	2561	0.442	2134						
			1160	7.6	0.473	3329	85	0.378	2663	0.315	2219						
			870	5.7	0.378	3394	82	0.302	2715	0.252	2263						
			600	3.9	0.285	3456	76	0.228	2765	0.190	2304						
			300	2.0	0.149	3526	74	0.119	2821	0.099	2351						
			100	0.7	0.052	3573	72	0.042	2858	0.035	2382						
182.3(H)	6.08	30	2500	13.7	0.766	3130	89	0.613	2504	0.511	2087	250	1350	2020	2400	2800	
			1750	9.6	0.57	3263	87	0.456	2610	0.380	2175						
			1160	6.4	0.41	3372	83	0.328	2698	0.273	2248						
			870	4.8	0.331	3427	79	0.265	2742	0.221	2285						
			600	3.3	0.239	3479	76	0.191	2783	0.159	2319						
			300	1.6	0.125	3538	74	0.100	2830	0.083	2359						
			100	0.5	0.044	3577	71	0.035	2862	0.029	2385						
200(D)	10	20	2500	12.5	0.761	3166	82	0.609	2533	0.507	2111	219	1350	1750	1966	2800	
			1750	8.8	0.561	3243	80	0.449	2594	0.374	2162						
			1160	5.8	0.387	3305	79	0.310	2644	0.258	2203						
			870	4.4	0.295	3336	78	0.236	2669	0.197	2224						
			600	3.0	0.206	3365	78	0.165	2692	0.137	2243						
			300	1.5	0.106	3397	76	0.085	2718	0.071	2265						
			100	0.5	0.039	3419	70	0.031	2735	0.026	2279						
202.6(H)	5.07	40	2500	12.3	0.682	3051	88	0.546	2441	0.455	2034	250	1350	2220	2400	2800	
			1750	8.6	0.529	3347	87	0.423	2678	0.353	2231						
			1160	5.7	0.348	3182	83	0.278	2546	0.232	2121						
			870	4.3	0.279	3249	79	0.223	2599	0.186	2166						
			600	3.0	0.214	3312	73	0.171	2650	0.143	2208						
			300	1.5	0.11	3344	71	0.088	2675	0.073	2229						
			100	0.5	0.039	3386	69	0.031	2709	0.026	2257						
253.3(H)	5.07	50	2500	9.9	0.545	2985	86	0.436	2388	0.363	1990	250	1350	2350	2400	2800	
			1750	6.9	0.418	3241	85	0.334	2593	0.279	2161						
			1160	4.6	0.272	3036	81	0.218	2429	0.181	2024						
			870	3.4	0.221	3131	77	0.177	2505	0.147	2087						
			600	2.4	0.172	3214	70	0.138	2571	0.115	2143						
			300	1.2	0.086	3136	69	0.069	2509	0.057	2091						
			100	0.4	0.03	3173	66	0.024	2538	0.020	2115						

1. Exact ratio.
 2. If input speed is below 1160 RPM, please specify speed and mounting position to ensure proper lubrication.
 3. Overhung load given at a distance equal to one shaft diameter from the face of the output seal.
 4. Overhung load is based on maximum bore size. Use of smaller driven shaft diameter may limit OHL capacity.

5. Overhung loads are based on the output shaft and output bearing capacities only. Check Overhung Load Section for other considerations.
 6. Overhung load and thrust load ratings are computed independent of each other. For combined load applications, contact Winsmith.

Ratings





DOUBLE REDUCTION

With Mobil Glygoyle 460 Lubricant

REDUCER SIZE

E30

CENTER DISTANCE DOUBLE WORM HELICAL WORM		PRIMARY 2.000 2.060	SECONDARY 3.000 3.000	HORSEPOWER AND TORQUE RATINGS								OVERHUNG LOAD CAPACITIES (lb)			THRUST LOAD CAPACITIES (lb)		
OVERALL RATIO ¹	PRIMARY RATIO ¹	SECONDARY RATIO ¹	INPUT RPM ²	OUTPUT RPM	MECHANICAL								ALL SHAFT INPUT MODELS	OUTPUT SHAFT ^{5,6}		OUTPUT SHAFT ⁶	
					1.00 SERVICE FACTOR		1.25 SERVICE FACTOR		1.50 SERVICE FACTOR		SOLID ³ SHAFT (e.g. MDND)	HOLLOW ⁴ SHAFT (e.g. MDSD)		SOLID SHAFT (e.g. MDND)	HOLLOW SHAFT (e.g. MDSD)		
					INPUT HP	OUTPUT TORQUE (lbf-in.)	EFF	INPUT HP	OUTPUT TORQUE (lbf-in.)	INPUT HP						OUTPUT TORQUE (lbf-in.)	
300(D)	20	15	2500	8.3	0.6	3365	74	0.480	2692	0.400	2243	236	1350	1583	1724	2711	
			1750	5.8	0.418	3409	75	0.334	2727	0.279	2273						
			1160	3.9	0.277	3444	76	0.222	2755	0.185	2296						
			870	2.9	0.209	3462	76	0.167	2770	0.139	2308						
			600	2.0	0.145	3478	76	0.116	2782	0.097	2319						
			300	1.0	0.074	3490	75	0.059	2792	0.049	2327						
100	0.3	0.027	3490	69	0.022	2792	0.018	2327									
303.8(H)	6.08	50	2500	8.2	0.477	3127	86	0.382	2502	0.318	2085	250	1350	2350	2400	2800	
			1750	5.8	0.323	2940	83	0.258	2352	0.215	1960						
			1160	3.8	0.238	3099	79	0.190	2479	0.159	2066						
			870	2.9	0.196	3180	74	0.157	2544	0.131	2120						
			600	2.0	0.137	3100	71	0.110	2480	0.091	2067						
			300	1.0	0.072	3146	68	0.058	2517	0.048	2097						
100	0.3	0.025	3176	66	0.020	2541	0.017	2117									
364.6(H)	6.08	60	2500	6.9	0.346	2627	83	0.277	2102	0.231	1751	250	1350	2350	2400	2800	
			1750	4.8	0.256	2721	81	0.205	2177	0.171	1814						
			1160	3.2	0.185	2797	76	0.148	2238	0.123	1865						
			870	2.4	0.149	2798	71	0.119	2238	0.099	1865						
			600	1.6	0.107	2798	68	0.086	2238	0.071	1865						
			300	0.8	0.055	2798	66	0.044	2238	0.037	1865						
100	0.3	0.021	3124	64	0.017	2499	0.014	2083									
500(D)	25	20	2500	5.0	0.377	3322	70	0.302	2658	0.251	2215	220	1350	1750	1966	2800	
			1750	3.5	0.261	3354	71	0.209	2683	0.174	2236						
			1160	2.3	0.172	3380	72	0.138	2704	0.115	2253						
			870	1.7	0.129	3392	72	0.103	2714	0.086	2261						
			600	1.2	0.09	3404	72	0.072	2723	0.060	2269						
			300	0.6	0.046	3417	71	0.037	2734	0.031	2278						
100	0.2	0.017	3426	65	0.014	2741	0.011	2284									
750(D)	25	30	2500	3.3	0.284	3478	65	0.227	2782	0.189	2319	220	1350	2020	2400	2800	
			1750	2.3	0.197	3513	66	0.158	2810	0.131	2342						
			1160	1.5	0.13	3541	67	0.104	2833	0.087	2361						
			870	1.2	0.098	3555	67	0.078	2844	0.065	2370						
			600	0.8	0.069	3568	66	0.055	2854	0.046	2379						
			300	0.4	0.035	3583	65	0.028	2866	0.023	2389						
100	0.1	0.013	3592	60	0.010	2874	0.009	2395									
1000(D)	50	20	2500	2.5	0.218	3376	61	0.174	2701	0.145	2251	224	1350	1750	1966	2800	
			1750	1.8	0.148	3392	64	0.118	2714	0.099	2261						
			1160	1.2	0.096	3405	66	0.077	2724	0.064	2270						
			870	0.9	0.072	3411	66	0.058	2729	0.048	2274						
			600	0.6	0.049	3417	66	0.039	2734	0.033	2278						
			300	0.3	0.025	3424	66	0.020	2739	0.017	2283						
100	0.1	0.009	3428	61	0.007	2742	0.006	2285									

1. Exact ratio.
 2. If input speed is below 1160 RPM, please specify speed and mounting position to ensure proper lubrication.
 3. Overhung load given at a distance equal to one shaft diameter from the face of the output seal.
 4. Overhung load is based on maximum bore size. Use of smaller driven shaft diameter may limit OHL capacity.

5. Overhung loads are based on the output shaft and output bearing capacities only. Check Overhung Load Section for other considerations.
 6. Overhung load and thrust load ratings are computed independent of each other. For combined load applications, contact Winsmith.

Ratings



2D DRAWINGS & 3D MODELS
www.WINSMITH.com



DOUBLE REDUCTION

With Mobil Glygoyle 460 Lubricant



CENTER DISTANCE DOUBLE WORM HELICAL WORM		PRIMARY 2.000 2.060	SECONDARY 3.000 3.000	HORSEPOWER AND TORQUE RATINGS								OVERHUNG LOAD CAPACITIES (lb)			THRUST LOAD CAPACITIES (lb)		
OVERALL RATIO ¹	PRIMARY RATIO ¹	SECONDARY RATIO ¹	INPUT RPM ²	OUTPUT RPM	MECHANICAL								INPUT SHAFT ALL SHAFT INPUT MODELS	OUTPUT SHAFT ^{5,6}		OUTPUT SHAFT ⁶	
					1.00 SERVICE FACTOR		1.25 SERVICE FACTOR		1.50 SERVICE FACTOR		SOLID ³ SHAFT (e.g. MDND)	HOLLOW ⁴ SHAFT (e.g. MDSD)		SOLID SHAFT (e.g. MDND)	HOLLOW SHAFT (e.g. MDSD)		
					INPUT HP	OUTPUT TORQUE (lbf-in.)	EFF	INPUT HP	OUTPUT TORQUE (lbf-in.)	INPUT HP						OUTPUT TORQUE (lbf-in.)	
1500(D)	50	30	2500	1.7	0.163	3537	57	0.130	2830	0.109	2358	224	1350	2020	2400	2800	
			1750	1.2	0.113	3555	58	0.090	2844	0.075	2370						
			1160	0.8	0.076	3569	57	0.061	2855	0.051	2379						
			870	0.6	0.057	3576	58	0.046	2861	0.038	2384						
			600	0.4	0.04	3583	57	0.032	2866	0.027	2389						
			300	0.2	0.021	3590	55	0.017	2872	0.014	2393						
			100	0.1	0.007	3595	53	0.006	2876	0.005	2397						
2000(D)	50	40	2500	1.3	0.123	3354	54	0.098	2683	0.082	2236	224	1350	2220	2400	2800	
			1750	0.9	0.083	3369	56	0.066	2695	0.055	2246						
			1160	0.6	0.054	3382	58	0.043	2706	0.036	2255						
			870	0.4	0.041	3388	58	0.033	2710	0.027	2259						
			600	0.3	0.028	3394	58	0.022	2715	0.019	2263						
			300	0.2	0.014	3400	58	0.011	2720	0.009	2267						
			100	0.1	0.005	3404	53	0.004	2723	0.003	2269						
3000(D)	60	50	2500	0.8	0.084	3153	49	0.067	2522	0.056	2102	224	1350	2350	2400	2800	
			1750	0.6	0.059	3164	50	0.047	2531	0.039	2109						
			1160	0.4	0.038	3174	51	0.030	2539	0.025	2116						
			870	0.3	0.028	3178	51	0.022	2542	0.019	2119						
			600	0.2	0.019	3182	53	0.015	2546	0.013	2121						
			300	0.1	0.009	3187	53	0.007	2550	0.006	2125						
			100	-	0.003	3190	49	0.002	2552	0.002	2127						
3600(D)	60	60	2500	0.7	0.066	2889	48	0.053	2311	0.044	1926	224	1350	2350	2400	2800	
			1750	0.5	0.049	3080	48	0.039	2464	0.033	2053						
			1160	0.3	0.032	3121	49	0.026	2497	0.021	2081						
			870	0.2	0.024	3142	50	0.019	2514	0.016	2095						
			600	0.2	0.016	3146	51	0.013	2517	0.011	2097						
			300	0.1	0.008	3167	52	0.006	2534	0.005	2111						
			100	-	0.003	3171	48	0.002	2537	0.002	2114						
4100(D)	82	50	2500	0.6	0.082	3163	38	0.066	2530	0.055	2109	220	1350	2350	2400	2800	
			1750	0.4	0.054	3171	41	0.043	2537	0.036	2114						
			1160	0.3	0.033	3178	44	0.026	2542	0.022	2119						
			870	0.2	0.024	3182	46	0.019	2546	0.016	2121						
			600	0.1	0.016	3185	47	0.013	2548	0.011	2123						
			300	0.1	0.008	3188	49	0.006	2550	0.005	2125						
			100	-	0.003	3191	45	0.002	2553	0.002	2127						

1. Exact ratio.
 2. If input speed is below 1160 RPM, please specify speed and mounting position to ensure proper lubrication.
 3. Overhung load given at a distance equal to one shaft diameter from the face of the output seal.
 4. Overhung load is based on maximum bore size. Use of smaller driven shaft diameter may limit OHL capacity.

5. Overhung loads are based on the output shaft and output bearing capacities only. Check Overhung Load Section for other considerations.
 6. Overhung load and thrust load ratings are computed independent of each other. For combined load applications, contact Winsmith.

Ratings





DOUBLE REDUCTION

With Mobil Glygoyle 460 Lubricant

REDUCER SIZE

E30

CENTER DISTANCE DOUBLE WORM HELICAL WORM		PRIMARY 2.000 2.060	SECONDARY 3.000 3.000	HORSEPOWER AND TORQUE RATINGS								OVERHUNG LOAD CAPACITIES (lb)			THRUST LOAD CAPACITIES (lb)		
OVERALL RATIO ¹	PRIMARY RATIO ¹	SECONDARY RATIO ¹	INPUT RPM ²	OUTPUT RPM	MECHANICAL								ALL SHAFT INPUT MODELS	OUTPUT SHAFT ^{5,6}		OUTPUT SHAFT ⁶	
					1.00 SERVICE FACTOR			1.25 SERVICE FACTOR			1.50 SERVICE FACTOR			SOLID ³ SHAFT (e.g. MDND)	HOLLOW ⁴ SHAFT (e.g. MDSD)	SOLID SHAFT (e.g. MDND)	HOLLOW SHAFT (e.g. MDSD)
					INPUT HP	OUTPUT TORQUE (lbf-in.)	EFF	INPUT HP	OUTPUT TORQUE (lbf-in.)	INPUT HP	OUTPUT TORQUE (lbf-in.)						
4950(D)	99	50	2500	0.5	0.077	3168	32	0.062	2534	0.051	2112	220	1350	2350	2400	2800	
			1750	0.4	0.05	3175	36	0.040	2540	0.033	2117						
			1160	0.2	0.03	3181	39	0.024	2545	0.020	2121						
			870	0.2	0.022	3184	40	0.018	2547	0.015	2123						
			600	0.1	0.014	3186	42	0.011	2549	0.009	2124						
			300	0.1	0.007	3189	45	0.006	2551	0.005	2126						
			100	–	0.002	3191	42	0.002	2553	0.001	2127						
5940(D)	99	60	2500	0.4	0.065	3100	31	0.052	2480	0.043	2067	220	1350	2350	2400	2800	
			1750	0.3	0.042	3123	34	0.034	2498	0.028	2082						
			1160	0.2	0.026	3145	37	0.021	2516	0.017	2097						
			870	0.1	0.018	3148	39	0.014	2518	0.012	2099						
			600	0.1	0.012	3166	41	0.010	2533	0.008	2111						
			300	0.1	0.006	3170	43	0.005	2536	0.004	2113						
			100	–	0.002	3172	40	0.002	2538	0.001	2115						
7920(D)	99	80	2500	0.3	0.034	2050	30	0.027	1640	0.023	1367	220	1350	2350	2400	2800	
			1750	0.2	0.022	2050	32	0.018	1640	0.015	1367						
			1160	0.1	0.013	2050	35	0.010	1640	0.009	1367						
			870	0.1	0.01	2050	37	0.008	1640	0.007	1367						
			600	0.1	0.006	2050	39	0.005	1640	0.004	1367						
			300	–	0.003	2050	41	0.002	1640	0.002	1367						
			100	–	0.001	2050	38	0.001	1640	0.001	1367						
9900(D)	99	100	2500	0.3	0.024	1696	28	0.019	1357	0.016	1131	220	1350	2350	2400	2800	
			1750	0.2	0.015	1696	31	0.012	1357	0.010	1131						
			1160	0.1	0.009	1696	34	0.007	1357	0.006	1131						
			870	0.1	0.007	1696	35	0.006	1357	0.005	1131						
			600	0.1	0.004	1696	37	0.003	1357	0.003	1131						
			300	–	0.002	1696	39	0.002	1357	0.001	1131						
			100	–	0.001	1696	37	0.001	1357	0.001	1131						

1. Exact ratio.
 2. If input speed is below 1160 RPM, please specify speed and mounting position to ensure proper lubrication.
 3. Overhung load given at a distance equal to one shaft diameter from the face of the output seal.
 4. Overhung load is based on maximum bore size. Use of smaller driven shaft diameter may limit OHL capacity.

5. Overhung loads are based on the output shaft and output bearing capacities only. Check Overhung Load Section for other considerations.
 6. Overhung load and thrust load ratings are computed independent of each other. For combined load applications, contact Winsmith.

Ratings



2D DRAWINGS & 3D MODELS
www.WINSMITH.com



DOUBLE REDUCTION

With Mobil Glygoyle 460 Lubricant



CENTER DISTANCE DOUBLE WORM HELICAL WORM		PRIMARY 2.000 2.060	SECONDARY 3.500 3.500	HORSEPOWER AND TORQUE RATINGS								OVERHUNG LOAD CAPACITIES (lb)			THRUST LOAD CAPACITIES (lb)		
OVERALL RATIO ¹	PRIMARY RATIO ¹	SECONDARY RATIO ¹	INPUT RPM ²	OUTPUT RPM	MECHANICAL								ALL SHAFT INPUT MODELS	OUTPUT SHAFT ^{5,6}		OUTPUT SHAFT ⁶	
					1.00 SERVICE FACTOR		1.25 SERVICE FACTOR		1.50 SERVICE FACTOR		SOLID ³ SHAFT (e.g. MDND)	HOLLOW ⁴ SHAFT (e.g. MDSD)		SOLID SHAFT (e.g. MDND)	HOLLOW SHAFT (e.g. MDSD)		
					INPUT HP	OUTPUT TORQUE (lb-ft-in.)	EFF	INPUT HP	OUTPUT TORQUE (lb-ft-in.)	INPUT HP						OUTPUT TORQUE (lb-ft-in.)	
25.3(H)	5.07	5	2500	98.6	2.825	1672	93	2.260	1338	1.883	1115	250	1720	1447	1744	2246	
			1750	69.0	3.207	2728	93	2.566	2182	2.138	1819						
			1160	45.8	2.208	2807	92	1.766	2246	1.472	1871						
			870	34.3	1.696	2844	91	1.357	2275	1.131	1896						
			600	23.7	1.207	2878	90	0.966	2302	0.805	1919						
			300	11.8	0.624	2929	88	0.499	2343	0.416	1953						
			100	3.9	0.216	2990	87	0.173	2392	0.144	1993						
30.4(H)	6.08	5	2500	82.2	3.681	2636	93	2.945	2109	2.454	1757	250	1720	1447	1744	2246	
			1750	57.6	2.659	2702	93	2.127	2162	1.773	1801						
			1160	38.2	1.835	2779	92	1.468	2223	1.223	1853						
			870	28.6	1.405	2800	91	1.124	2240	0.937	1867						
			600	19.7	0.999	2860	90	0.799	2288	0.666	1907						
			300	9.9	0.518	2906	88	0.414	2325	0.345	1937						
			100	3.3	0.177	2920	86	0.142	2336	0.118	1947						
38.0(H)	5.07	7.5	2500	65.7	4.288	3858	94	3.430	3086	2.859	2572	250	1882	1582	1997	2612	
			1750	46.0	3.209	4100	93	2.567	3280	2.139	2733						
			1160	30.5	2.214	4218	92	1.771	3374	1.476	2812						
			870	22.9	1.699	4260	91	1.359	3408	1.133	2840						
			600	15.8	1.206	4276	89	0.965	3421	0.804	2851						
			300	7.9	0.621	4331	87	0.497	3465	0.414	2887						
			100	2.6	0.215	4402	86	0.172	3522	0.143	2935						
50(D)	5	10	2500	50.0	3.507	3907	88	2.806	3126	2.338	2605	303	2064	1734	2200	2903	
			1750	35.0	3.109	4992	89	2.487	3994	2.073	3328						
			1160	23.2	2.12	5104	89	1.696	4083	1.413	3403						
			870	17.4	1.74	5526	88	1.392	4421	1.160	3684						
			600	12.0	1.29	5807	86	1.032	4646	0.860	3871						
			300	6.0	0.62	5497	84	0.496	4398	0.413	3665						
			100	2.0	0.224	5601	79	0.179	4481	0.149	3734						
50.7(H)	5.07	10	2500	49.3	3.799	4510	93	3.039	3608	2.533	3007	250	2064	1734	2200	2903	
			1750	34.5	3.215	5419	92	2.572	4335	2.143	3613						
			1160	22.9	2.067	5168	91	1.654	4134	1.378	3445						
			870	17.2	1.689	5538	89	1.351	4430	1.126	3692						
			600	11.8	1.2	5552	87	0.960	4442	0.800	3701						
			300	5.9	0.603	5499	86	0.482	4399	0.402	3666						
			100	2.0	0.209	5588	84	0.167	4470	0.139	3725						
60.8(H)	6.08	10	2500	41.1	3.374	4788	93	2.699	3830	2.249	3192	250	2064	1734	2200	2903	
			1750	28.8	2.243	4494	92	1.794	3595	1.495	2996						
			1160	19.1	1.8	5346	90	1.440	4277	1.200	3564						
			870	14.3	1.407	5456	88	1.126	4365	0.938	3637						
			600	9.9	0.977	5398	87	0.782	4318	0.651	3599						
			300	4.9	0.505	5501	85	0.404	4401	0.337	3667						
			100	1.6	0.176	5611	83	0.141	4489	0.117	3741						

1. Exact ratio.
 2. If input speed is below 1160 RPM, please specify speed and mounting position to ensure proper lubrication.
 3. Overhung load given at a distance equal to one shaft diameter from the face of the output seal.
 4. Overhung load is based on maximum bore size. Use of smaller driven shaft diameter may limit OHL capacity.

5. Overhung loads are based on the output shaft and output bearing capacities only. Check Overhung Load Section for other considerations.
 6. Overhung load and thrust load ratings are computed independent of each other. For combined load applications, contact WinSmith.

Ratings





DOUBLE REDUCTION

With Mobil Glygoyle 460 Lubricant

REDUCER SIZE

E35

CENTER DISTANCE DOUBLE WORM HELICAL WORM		PRIMARY 2.000 2.060	SECONDARY 3.500 3.500	HORSEPOWER AND TORQUE RATINGS								OVERHUNG LOAD CAPACITIES (lb)			THRUST LOAD CAPACITIES (lb)		
OVERALL RATIO ¹	PRIMARY RATIO ¹	SECONDARY RATIO ¹	INPUT RPM ²	OUTPUT RPM	MECHANICAL								ALL SHAFT INPUT MODELS	SOLID ³ SHAFT (e.g. MDND)	HOLLOW ⁴ SHAFT (e.g. MDSD)	OUTPUT SHAFT ⁶	
					1.00 SERVICE FACTOR		1.25 SERVICE FACTOR		1.50 SERVICE FACTOR		SOLID SHAFT (e.g. MDND)	HOLLOW SHAFT (e.g. MDSD)					
					INPUT HP	OUTPUT TORQUE (lb·in.)	EFF	INPUT HP	OUTPUT TORQUE (lb·in.)	INPUT HP						OUTPUT TORQUE (lb·in.)	
75(D)	5	15	2500	33.3	3.864	6437	88	3.091	5150	2.576	4291	303	2130	1998	2624	3339	
			1750	23.3	2.883	6891	88	2.306	5513	1.922	4594						
			1160	15.5	2.032	7270	88	1.626	5816	1.355	4847						
			870	11.6	1.586	7464	87	1.269	5971	1.057	4976						
			600	8.0	1.157	7649	84	0.926	6119	0.771	5099						
			300	4.0	0.619	7861	81	0.495	6289	0.413	5241						
			100	1.3	0.225	8005	75	0.180	6404	0.150	5337						
76.0(H)	5.07	15	2500	32.9	3.648	6458	92	2.918	5166	2.432	4305	250	2130	1998	2624	3339	
			1750	23.0	2.756	6906	92	2.205	5525	1.837	4604						
			1160	15.3	1.96	7281	90	1.568	5825	1.307	4854						
			870	11.4	1.538	7472	88	1.230	5978	1.025	4981						
			600	7.9	1.127	7655	85	0.902	6124	0.751	5103						
			300	3.9	0.602	7864	82	0.482	6291	0.401	5243						
			100	1.3	0.21	8006	79	0.168	6405	0.140	5337						
91.1(H)	6.08	15	2500	27.4	3.17	6702	92	2.536	5362	2.113	4468	250	2130	1998	2624	3339	
			1750	19.2	2.374	7088	91	1.899	5670	1.583	4725						
			1160	12.7	1.682	7407	89	1.346	5926	1.121	4938						
			870	9.5	1.32	7570	87	1.056	6056	0.880	5047						
			600	6.6	0.947	7724	85	0.758	6179	0.631	5149						
			300	3.3	0.506	7899	81	0.405	6319	0.337	5266						
			100	1.1	0.176	8018	79	0.141	6414	0.117	5345						
100(D)	5	20	2500	25.0	2.762	6079	87	2.210	4863	1.841	4053	303	2130	2204	2973	3660	
			1750	17.5	2.123	6708	88	1.698	5366	1.415	4472						
			1160	11.6	1.326	6247	87	1.061	4998	0.884	4165						
			870	8.7	1.061	6563	85	0.849	5250	0.707	4375						
			600	6.0	0.793	6869	82	0.634	5495	0.529	4579						
			300	3.0	0.394	6499	78	0.315	5199	0.263	4333						
			100	1.0	0.143	6607	73	0.114	5286	0.095	4405						
101.3(H)	5.07	20	2500	24.7	2.611	6106	92	2.089	4885	1.741	4071	250	2130	2204	2973	3660	
			1750	17.3	2.032	6728	91	1.626	5382	1.355	4485						
			1160	11.4	1.281	6264	89	1.025	5011	0.854	4176						
			870	8.6	1.03	6577	87	0.824	5262	0.687	4385						
			600	5.9	0.773	6878	84	0.618	5502	0.515	4585						
			300	3.0	0.383	6502	80	0.306	5202	0.255	4335						
			100	1.0	0.134	6608	77	0.107	5286	0.089	4405						
121.5(H)	6.08	20	2500	20.6	2.306	6444	91	1.845	5155	1.537	4296	250	2130	2204	2973	3660	
			1750	14.4	1.514	5952	90	1.211	4762	1.009	3968						
			1160	9.5	1.117	6470	88	0.894	5176	0.745	4313						
			870	7.2	0.895	6737	86	0.716	5390	0.597	4491						
			600	4.9	0.6	6397	84	0.480	5118	0.400	4265						
			300	2.5	0.322	6528	79	0.258	5222	0.215	4352						
			100	0.8	0.112	6617	77	0.090	5294	0.075	4411						

Ratings

1. Exact ratio.
 2. If input speed is below 1160 RPM, please specify speed and mounting position to ensure proper lubrication.
 3. Overhung load given at a distance equal to one shaft diameter from the face of the output seal.
 4. Overhung load is based on maximum bore size. Use of smaller driven shaft diameter may limit OHL capacity.

5. Overhung loads are based on the output shaft and output bearing capacities only. Check Overhung Load Section for other considerations.
 6. Overhung load and thrust load ratings are computed independent of each other. For combined load applications, contact Winsmith.



2D DRAWINGS & 3D MODELS
www.WINSMITH.com



DOUBLE REDUCTION

With Mobil Glygoyle 460 Lubricant



CENTER DISTANCE DOUBLE WORM HELICAL WORM		PRIMARY 2.000 2.060	SECONDARY 3.500 3.500	HORSEPOWER AND TORQUE RATINGS								OVERHUNG LOAD CAPACITIES (lb)			THRUST LOAD CAPACITIES (lb)		
OVERALL RATIO ¹	PRIMARY RATIO ¹	SECONDARY RATIO ¹	INPUT RPM ²	OUTPUT RPM	MECHANICAL								ALL SHAFT INPUT MODELS	OUTPUT SHAFT ^{5,6}		OUTPUT SHAFT ⁶	
					1.00 SERVICE FACTOR		1.25 SERVICE FACTOR		1.50 SERVICE FACTOR		SOLID ³ SHAFT (e.g. MDND)	HOLLOW ⁴ SHAFT (e.g. MDSD)		SOLID SHAFT (e.g. MDND)	HOLLOW SHAFT (e.g. MDSD)		
					INPUT HP	OUTPUT TORQUE (lbf-in.)	EFF	INPUT HP	OUTPUT TORQUE (lbf-in.)	INPUT HP						OUTPUT TORQUE (lbf-in.)	
150(D)	10	15	2500	16.7	2.262	7211	84	1.810	5769	1.508	4807	219	2130	1998	2624	3339	
			1750	11.7	1.647	7461	84	1.318	5969	1.098	4974						
			1160	7.7	1.153	7663	82	0.922	6130	0.769	5109						
			870	5.8	0.891	7765	80	0.713	6212	0.594	5177						
			600	4.0	0.632	7861	79	0.506	6289	0.421	5241						
			300	2.0	0.326	7968	78	0.261	6374	0.217	5312						
			100	0.7	0.12	8041	71	0.096	6433	0.080	5361						
152.0(H)	5.07	30	2500	16.4	1.934	6641	90	1.547	5313	1.289	4427	250	2130	2528	3520	4000	
			1750	11.5	1.461	7092	89	1.169	5674	0.974	4728						
			1160	7.6	0.995	7124	87	0.796	5699	0.663	4749						
			870	5.7	0.8	7464	85	0.640	5971	0.533	4976						
			600	3.9	0.602	7792	81	0.482	6234	0.401	5195						
			300	2.0	0.309	7477	76	0.247	5982	0.206	4985						
			100	0.7	0.113	7610	70	0.090	6088	0.075	5073						
182.3(H)	6.08	30	2500	13.7	1.679	6887	89	1.343	5510	1.119	4591	250	2130	2528	3520	4000	
			1750	9.6	1.177	6787	88	0.942	5430	0.785	4525						
			1160	6.4	0.867	7349	86	0.694	5879	0.578	4899						
			870	4.8	0.696	7638	83	0.557	6110	0.464	5092						
			600	3.3	0.473	7347	81	0.378	5878	0.315	4898						
			300	1.6	0.259	7510	76	0.207	6008	0.173	5007						
			100	0.5	0.092	7621	72	0.074	6097	0.061	5081						
200(D)	10	20	2500	12.5	1.465	6151	83	1.172	4921	0.977	4101	219	2130	2204	2973	3660	
			1750	8.8	1.101	6558	83	0.881	5246	0.734	4372						
			1160	5.8	0.792	6892	80	0.634	5514	0.528	4595						
			870	4.4	0.565	6428	78	0.452	5142	0.377	4285						
			600	3.0	0.402	6499	77	0.322	5199	0.268	4333						
			300	1.5	0.208	6580	75	0.166	5264	0.139	4387						
			100	0.5	0.077	6634	69	0.062	5307	0.051	4423						
202.6(H)	5.07	40	2500	12.3	1.414	6377	88	1.131	5102	0.943	4251	250	2130	2784	3520	4000	
			1750	8.6	1.062	6770	87	0.850	5416	0.708	4513						
			1160	5.7	0.735	6900	85	0.588	5520	0.490	4600						
			870	4.3	0.578	7045	83	0.462	5636	0.385	4697						
			600	3.0	0.418	7032	79	0.334	5626	0.279	4688						
			300	1.5	0.231	7221	74	0.185	5777	0.154	4814						
			100	0.5	0.084	7391	69	0.067	5913	0.056	4927						
253.3(H)	5.07	50	2500	9.9	0.942	5172	86	0.754	4138	0.628	3448	250	2130	3025	3520	4000	
			1750	6.9	0.67	5196	85	0.536	4157	0.447	3464						
			1160	4.6	0.456	5197	83	0.365	4158	0.304	3465						
			870	3.4	0.351	5187	81	0.281	4150	0.234	3458						
			600	2.4	0.255	5171	76	0.204	4137	0.170	3447						
			300	1.2	0.148	5574	71	0.118	4459	0.099	3716						
			100	0.4	0.061	6557	67	0.049	5246	0.041	4371						

1. Exact ratio.
 2. If input speed is below 1160 RPM, please specify speed and mounting position to ensure proper lubrication.
 3. Overhung load given at a distance equal to one shaft diameter from the face of the output seal.
 4. Overhung load is based on maximum bore size. Use of smaller driven shaft diameter may limit OHL capacity.

5. Overhung loads are based on the output shaft and output bearing capacities only. Check Overhung Load Section for other considerations.
 6. Overhung load and thrust load ratings are computed independent of each other. For combined load applications, contact Winsmith.

Ratings





DOUBLE REDUCTION

With Mobil Glygoyle 460 Lubricant

REDUCER SIZE

E35

CENTER DISTANCE DOUBLE WORM HELICAL WORM		PRIMARY 2.000 2.060	SECONDARY 3.500 3.500	HORSEPOWER AND TORQUE RATINGS								OVERHUNG LOAD CAPACITIES (lb)			THRUST LOAD CAPACITIES (lb)		
OVERALL RATIO ¹	PRIMARY RATIO ¹	SECONDARY RATIO ¹	INPUT RPM ²	OUTPUT RPM	MECHANICAL								ALL SHAFT INPUT MODELS	OUTPUT SHAFT ^{5,6}		OUTPUT SHAFT ⁶	
					1.00 SERVICE FACTOR		1.25 SERVICE FACTOR		1.50 SERVICE FACTOR		SOLID ³ SHAFT (e.g. MDND)	HOLLOW ⁴ SHAFT (e.g. MDSD)		SOLID SHAFT (e.g. MDND)	HOLLOW SHAFT (e.g. MDSD)		
					INPUT HP	OUTPUT TORQUE (lbf-in.)	EFF	INPUT HP	OUTPUT TORQUE (lbf-in.)	INPUT HP						OUTPUT TORQUE (lbf-in.)	
300(D)	20	15	2500	8.3	1.337	7632	75	1.070	6106	0.891	5088	247	2130	1998	2624	3339	
			1750	5.8	0.949	7763	76	0.759	6210	0.633	5175						
			1160	3.9	0.64	7868	75	0.512	6294	0.427	5245						
			870	2.9	0.484	7920	75	0.387	6336	0.323	5280						
			600	2.0	0.337	7968	75	0.270	6374	0.225	5312						
			300	1.0	0.173	8023	74	0.138	6418	0.115	5349						
			100	0.3	0.063	8059	68	0.050	6447	0.042	5373						
303.8(H)	6.08	50	2500	8.2	0.793	5198	86	0.634	4158	0.529	3465	250	2130	3025	3520	4000	
			1750	5.8	0.563	5181	84	0.450	4145	0.375	3454						
			1160	3.8	0.387	5199	81	0.310	4159	0.258	3466						
			870	2.9	0.299	5170	79	0.239	4136	0.199	3447						
			600	2.0	0.213	5188	76	0.170	4150	0.142	3459						
			300	1.0	0.127	5740	71	0.102	4592	0.085	3827						
			100	0.3	0.05	6599	69	0.040	5279	0.033	4399						
364.6(H)	6.08	60	2500	6.9	0.546	4149	83	0.437	3319	0.364	2766	250	2130	3186	3520	4000	
			1750	4.8	0.404	4339	82	0.323	3471	0.269	2893						
			1160	3.2	0.287	4495	79	0.230	3596	0.191	2997						
			870	2.4	0.227	4573	76	0.182	3658	0.151	3049						
			600	1.6	0.164	4648	74	0.131	3718	0.109	3099						
			300	0.8	0.09	4732	68	0.072	3786	0.060	3155						
			100	0.3	0.033	5030	67	0.026	4024	0.022	3353						
500(D)	25	20	2500	5.0	0.725	6394	70	0.580	5115	0.483	4263	220	2130	2204	2973	3660	
			1750	3.5	0.508	6473	71	0.406	5178	0.339	4315						
			1160	2.3	0.336	6536	72	0.269	5229	0.224	4357						
			870	1.7	0.253	6567	72	0.202	5254	0.169	4378						
			600	1.2	0.176	6596	71	0.141	5277	0.117	4397						
			300	0.6	0.09	6629	70	0.072	5303	0.060	4419						
			100	0.2	0.033	6650	64	0.026	5320	0.022	4433						
750(D)	25	30	2500	3.3	0.575	7343	68	0.460	5874	0.383	4895	220	2130	2528	3520	4000	
			1750	2.3	0.41	7442	67	0.328	5954	0.273	4961						
			1160	1.5	0.282	7520	65	0.226	6016	0.188	5013						
			870	1.2	0.213	7559	65	0.170	6047	0.142	5039						
			600	0.8	0.149	7595	65	0.119	6076	0.099	5063						
			300	0.4	0.076	7636	64	0.061	6109	0.051	5091						
			100	0.1	0.028	7663	59	0.022	6130	0.019	5109						
1000(D)	50	20	2500	2.5	0.426	6526	61	0.341	5221	0.284	4351	224	2130	2204	2973	3660	
			1750	1.8	0.289	6566	63	0.231	5253	0.193	4377						
			1160	1.2	0.187	6598	65	0.150	5278	0.125	4399						
			870	0.9	0.141	6614	65	0.113	5291	0.094	4409						
			600	0.6	0.097	6629	65	0.078	5303	0.065	4419						
			300	0.3	0.049	6645	65	0.039	5316	0.033	4430						
			100	0.1	0.018	6656	59	0.014	5325	0.012	4437						

Ratings

1. Exact ratio.
 2. If input speed is below 1160 RPM, please specify speed and mounting position to ensure proper lubrication.
 3. Overhung load given at a distance equal to one shaft diameter from the face of the output seal.
 4. Overhung load is based on maximum bore size. Use of smaller driven shaft diameter may limit OHL capacity.

5. Overhung loads are based on the output shaft and output bearing capacities only. Check Overhung Load Section for other considerations.
 6. Overhung load and thrust load ratings are computed independent of each other. For combined load applications, contact Winsmith.



2D DRAWINGS & 3D MODELS
www.WINSMITH.com



DOUBLE REDUCTION

With Mobil Glygoyle 460 Lubricant



CENTER DISTANCE DOUBLE WORM HELICAL WORM		PRIMARY 2.000 2.060	SECONDARY 3.500 3.500	HORSEPOWER AND TORQUE RATINGS								OVERHUNG LOAD CAPACITIES (lb)			THRUST LOAD CAPACITIES (lb)		
OVERALL RATIO ¹	PRIMARY RATIO ¹	SECONDARY RATIO ¹	INPUT RPM ²	OUTPUT RPM	MECHANICAL								ALL SHAFT INPUT MODELS	OUTPUT SHAFT ^{5,6}		OUTPUT SHAFT ⁶	
					1.00 SERVICE FACTOR		1.25 SERVICE FACTOR		1.50 SERVICE FACTOR		SOLID ³ SHAFT (e.g. MDND)	HOLLOW ⁴ SHAFT (e.g. MDSD)		SOLID SHAFT (e.g. MDND)	HOLLOW SHAFT (e.g. MDSD)		
					INPUT HP	OUTPUT TORQUE (lbf-in.)	EFF	INPUT HP	OUTPUT TORQUE (lbf-in.)	INPUT HP						OUTPUT TORQUE (lbf-in.)	
1500(D)	50	30	2500	1.7	0.351	7508	57	0.281	6006	0.234	5005	224	2130	2528	3520	4000	
			1750	1.2	0.244	7558	57	0.195	6046	0.163	5039						
			1160	0.8	0.165	7598	56	0.132	6078	0.110	5065						
			870	0.6	0.123	7617	57	0.098	6094	0.082	5078						
			600	0.4	0.086	7636	56	0.069	6109	0.057	5091						
			300	0.2	0.045	7656	54	0.036	6125	0.030	5104						
			100	0.1	0.015	7670	53	0.012	6136	0.010	5113						
2000(D)	50	40	2500	1.3	0.269	7301	54	0.215	5841	0.179	4867	224	2130	2784	3520	4000	
			1750	0.9	0.184	7345	55	0.147	5876	0.123	4897						
			1160	0.6	0.12	7380	57	0.096	5904	0.080	4920						
			870	0.4	0.09	7398	57	0.072	5918	0.060	4932						
			600	0.3	0.061	7414	57	0.049	5931	0.041	4943						
			300	0.2	0.03	7432	58	0.024	5946	0.020	4955						
			100	0.1	0.011	7444	54	0.009	5955	0.007	4963						
3000(D)	60	50	2500	0.8	0.161	5935	49	0.129	4748	0.107	3957	224	2130	3025	3520	4000	
			1750	0.6	0.118	6305	50	0.094	5044	0.079	4203						
			1160	0.4	0.08	6558	50	0.064	5246	0.053	4372						
			870	0.3	0.059	6605	51	0.047	5284	0.039	4403						
			600	0.2	0.04	6685	53	0.032	5348	0.027	4457						
			300	0.1	0.02	6767	54	0.016	5414	0.013	4511						
			100	-	0.007	6811	51	0.006	5449	0.005	4541						
3600(D)	60	60	2500	0.7	0.11	4728	47	0.088	3782	0.073	3152	224	2130	3186	3520	4000	
			1750	0.5	0.08	4954	48	0.064	3963	0.053	3303						
			1160	0.3	0.053	5024	49	0.042	4019	0.035	3349						
			870	0.2	0.039	5034	50	0.031	4027	0.026	3356						
			600	0.2	0.026	5069	51	0.021	4055	0.017	3379						
			300	0.1	0.013	5105	52	0.010	4084	0.009	3403						
			100	-	0.005	5113	49	0.004	4090	0.003	3409						
4100(D)	82	50	2500	0.6	0.163	6237	38	0.130	4990	0.109	4158	220	2130	3025	3520	4000	
			1750	0.4	0.112	6518	40	0.090	5214	0.075	4345						
			1160	0.3	0.07	6605	44	0.056	5284	0.047	4403						
			870	0.2	0.051	6682	46	0.041	5346	0.034	4455						
			600	0.1	0.034	6725	48	0.027	5380	0.023	4483						
			300	0.1	0.016	6770	50	0.013	5416	0.011	4513						
			100	-	0.006	6812	47	0.005	5450	0.004	4541						

1. Exact ratio.
 2. If input speed is below 1160 RPM, please specify speed and mounting position to ensure proper lubrication.
 3. Overhung load given at a distance equal to one shaft diameter from the face of the output seal.
 4. Overhung load is based on maximum bore size. Use of smaller driven shaft diameter may limit OHL capacity.

5. Overhung loads are based on the output shaft and output bearing capacities only. Check Overhung Load Section for other considerations.
 6. Overhung load and thrust load ratings are computed independent of each other. For combined load applications, contact Winsmith.

Ratings





DOUBLE REDUCTION

With Mobil Glygoyle 460 Lubricant

REDUCER SIZE

E35

CENTER DISTANCE DOUBLE WORM HELICAL WORM		PRIMARY 2.000 2.060	SECONDARY 3.500 3.500	HORSEPOWER AND TORQUE RATINGS								OVERHUNG LOAD CAPACITIES (lb)			THRUST LOAD CAPACITIES (lb)		
OVERALL RATIO ¹	PRIMARY RATIO ¹	SECONDARY RATIO ¹	INPUT RPM ²	OUTPUT RPM	MECHANICAL								ALL SHAFT INPUT MODELS	SOLID ³ SHAFT (e.g. MDND)	HOLLOW ⁴ SHAFT (e.g. MDSD)	OUTPUT SHAFT ⁶	
					1.00 SERVICE FACTOR		1.25 SERVICE FACTOR		1.50 SERVICE FACTOR		SOLID SHAFT (e.g. MDND)	HOLLOW SHAFT (e.g. MDSD)					
			INPUT HP	OUTPUT TORQUE (lbf-in.)	EFF	INPUT HP	OUTPUT TORQUE (lbf-in.)	INPUT HP	OUTPUT TORQUE (lbf-in.)	INPUT HP	OUTPUT TORQUE (lbf-in.)						
4950(D)	99	50	2500	0.5	0.16	6477	32	0.128	5182	0.107	4318	220	2130	3025	3520	4000	
			1750	0.4	0.103	6563	35	0.082	5250	0.069	4375						
			1160	0.2	0.063	6647	39	0.050	5318	0.042	4431						
			870	0.2	0.045	6688	41	0.036	5350	0.030	4459						
			600	0.1	0.03	6730	43	0.024	5384	0.020	4487						
			300	0.1	0.014	6773	46	0.011	5418	0.009	4515						
			100	-	0.005	6813	43	0.004	5450	0.003	4542						
5940(D)	99	60	2500	0.4	0.106	4988	31	0.085	3990	0.071	3325	220	2130	3186	3520	4000	
			1750	0.3	0.068	5028	34	0.054	4022	0.045	3352						
			1160	0.2	0.042	5066	37	0.034	4053	0.028	3377						
			870	0.1	0.03	5072	39	0.024	4058	0.020	3381						
			600	0.1	0.019	5103	42	0.015	4082	0.013	3402						
			300	0.1	0.009	5110	44	0.007	4088	0.006	3407						
			100	-	0.003	5114	42	0.002	4091	0.002	3409						
7920(D)	99	80	2500	0.3	0.064	3818	29	0.051	3054	0.043	2545	220	2130	3357	3520	4000	
			1750	0.2	0.041	3828	32	0.033	3062	0.027	2552						
			1160	0.1	0.025	3836	35	0.020	3069	0.017	2557						
			870	0.1	0.018	3840	37	0.014	3072	0.012	2560						
			600	0.1	0.012	3843	39	0.010	3074	0.008	2562						
			300	-	0.006	3847	41	0.005	3078	0.004	2565						
			100	-	0.002	3850	39	0.002	3080	0.001	2567						
9900(D)	100	100	2500	0.3	0.041	2940	28	0.033	2352	0.027	1960	220	2130	3357	3520	4000	
			1750	0.2	0.027	2948	31	0.022	2358	0.018	1965						
			1160	0.1	0.016	2953	33	0.013	2362	0.011	1969						
			870	0.1	0.012	2956	35	0.010	2365	0.008	1971						
			600	0.1	0.008	2959	37	0.006	2367	0.005	1973						
			300	-	0.004	2962	39	0.003	2370	0.003	1975						
			100	-	0.001	2964	36	0.001	2371	0.001	1976						

1. Exact ratio.
 2. If input speed is below 1160 RPM, please specify speed and mounting position to ensure proper lubrication.
 3. Overhung load given at a distance equal to one shaft diameter from the face of the output seal.
 4. Overhung load is based on maximum bore size. Use of smaller driven shaft diameter may limit OHL capacity.

5. Overhung loads are based on the output shaft and output bearing capacities only. Check Overhung Load Section for other considerations.
 6. Overhung load and thrust load ratings are computed independent of each other. For combined load applications, contact Winsmith.

Ratings



2D DRAWINGS & 3D MODELS
www.WINSMITH.com



DOUBLE REDUCTION

With Mobil Glygoyle 460 Lubricant



CENTER DISTANCE DOUBLE WORM HELICAL WORM		PRIMARY 2.625 3.200	SECONDARY 4.250 4.250	HORSEPOWER AND TORQUE RATINGS								OVERHUNG LOAD CAPACITIES (lb)			THRUST LOAD CAPACITIES (lb)		
OVERALL RATIO ¹	PRIMARY RATIO ¹	SECONDARY RATIO ¹	INPUT RPM ²	OUTPUT RPM	MECHANICAL								INPUT SHAFT ALL SHAFT INPUT MODELS	OUTPUT SHAFT ^{5,6}		OUTPUT SHAFT ⁶	
					1.00 SERVICE FACTOR		1.25 SERVICE FACTOR		1.50 SERVICE FACTOR		SOLID ³ SHAFT (e.g. MDND)	HOLLOW ⁴ SHAFT (e.g. MDSD)		SOLID SHAFT (e.g. MDND)	HOLLOW SHAFT (e.g. MDSD)		
					INPUT HP	OUTPUT TORQUE (lb-ft-in.)	EFF	INPUT HP	OUTPUT TORQUE (lb-ft-in.)	INPUT HP						OUTPUT TORQUE (lb-ft-in.)	
25.3(H)	5.06	5	2500	98.8	14.094	8404	93	11.275	6723	9.396	5603	500	2175	2320	2337	3955	
			1750	69.2	11.009	9309	93	8.807	7447	7.339	6206						
			1160	45.8	7.714	9756	92	6.171	7805	5.143	6504						
			870	34.4	5.875	9847	91	4.700	7878	3.917	6565						
			600	23.7	4.054	9778	91	3.243	7822	2.703	6519						
			300	11.9	2.062	9817	90	1.650	7854	1.375	6545						
			100	4.0	0.645	9065	88	0.516	7252	0.430	6043						
29.6(H)	5.93	5	2500	84.3	12.657	8810	93	10.126	7048	8.438	5873	500	2175	2320	2337	3955	
			1750	59.0	9.183	9063	92	7.346	7250	6.122	6042						
			1160	39.1	6.241	9212	92	4.993	7370	4.161	6141						
			870	29.3	4.729	9251	91	3.783	7401	3.153	6167						
			600	20.2	3.23	9094	90	2.584	7275	2.153	6063						
			300	10.1	1.616	8985	89	1.293	7188	1.077	5990						
			100	3.4	0.513	8427	88	0.410	6742	0.342	5618						
38.0(H)	5.06	7.5	2500	65.9	10.755	9464	92	8.604	7571	7.170	6309	500	2518	2660	2697	4500	
			1750	46.1	8.364	10417	91	6.691	8334	5.576	6945						
			1160	30.6	6.044	11234	90	4.835	8987	4.029	7489						
			870	22.9	4.739	11659	89	3.791	9327	3.159	7773						
			600	15.8	3.415	12069	89	2.732	9655	2.277	8046						
			300	7.9	1.802	12541	87	1.442	10033	1.201	8361						
			100	2.6	0.629	12866	86	0.503	10293	0.419	8577						
50(D)	5	10	2500	50.0	8.837	9765	88	7.070	7812	5.891	6510	500	2786	2930	2972	4500	
			1750	35.0	7.019	11058	87	5.615	8846	4.679	7372						
			1160	23.2	5.044	11905	87	4.035	9524	3.363	7937						
			870	17.4	3.946	12344	86	3.157	9875	2.631	8229						
			600	12.0	2.844	12768	85	2.275	10214	1.896	8512						
			300	6.0	1.517	13256	83	1.214	10605	1.011	8837						
			100	2.0	0.572	13591	75	0.458	10873	0.381	9061						
50.6(H)	5.06	10	2500	49.4	8.755	10106	90	7.004	8085	5.837	6737	500	2786	2930	2972	4500	
			1750	34.6	6.798	11087	89	5.438	8870	4.532	7391						
			1160	22.9	4.909	11925	88	3.927	9540	3.273	7950						
			870	17.2	3.85	12360	88	3.080	9888	2.567	8240						
			600	11.9	2.775	12779	87	2.220	10223	1.850	8519						
			300	5.9	1.466	13262	85	1.173	10610	0.977	8841						
			100	2.0	0.512	13593	83	0.410	10874	0.341	9062						
59.3(H)	5.93	10	2500	42.2	7.861	10574	90	6.289	8459	5.241	7049	500	2786	2930	2972	4500	
			1750	29.5	6.022	11444	89	4.818	9155	4.015	7629						
			1160	19.6	4.302	12178	88	3.442	9742	2.868	8119						
			870	14.7	3.355	12556	87	2.684	10045	2.237	8371						
			600	10.1	2.406	12919	86	1.925	10335	1.604	8613						
			300	5.1	1.264	13334	85	1.011	10667	0.843	8889						
			100	1.7	0.441	13618	83	0.353	10894	0.294	9079						

1. Exact ratio.
 2. If input speed is below 1160 RPM, please specify speed and mounting position to ensure proper lubrication.
 3. Overhung load given at a distance equal to one shaft diameter from the face of the output seal.
 4. Overhung load is based on maximum bore size. Use of smaller driven shaft diameter may limit OHL capacity.

5. Overhung loads are based on the output shaft and output bearing capacities only. Check Overhung Load Section for other considerations.
 6. Overhung load and thrust load ratings are computed independent of each other. For combined load applications, contact Winsmith.

Ratings





DOUBLE REDUCTION

With Mobil Glygoyle 460 Lubricant

REDUCER SIZE

E43

CENTER DISTANCE DOUBLE WORM HELICAL WORM		PRIMARY 2.625 3.200	SECONDARY 4.250 4.250	HORSEPOWER AND TORQUE RATINGS								OVERHUNG LOAD CAPACITIES (lb)			THRUST LOAD CAPACITIES (lb)	
OVERALL RATIO ¹	PRIMARY RATIO ¹	SECONDARY RATIO ¹	INPUT RPM ²	OUTPUT RPM	MECHANICAL						ALL SHAFT INPUT MODELS	INPUT SHAFT		OUTPUT SHAFT ^{5,6}		
					1.00 SERVICE FACTOR		1.25 SERVICE FACTOR		1.50 SERVICE FACTOR			SOLID ³ SHAFT (e.g. MDND)	HOLLOW ⁴ SHAFT (e.g. MDSD)	SOLID SHAFT (e.g. MDND)	HOLLOW SHAFT (e.g. MDSD)	
INPUT HP	OUTPUT TORQUE (lbf-in.)	EFF	INPUT HP	OUTPUT TORQUE (lbf-in.)	INPUT HP	OUTPUT TORQUE (lbf-in.)	INPUT HP	OUTPUT TORQUE (lbf-in.)	500	2800	3340					3577
75(D)	5	15	2500	33.3	6.713	10774	85	5.370	8619	4.475	7183	500	2800	3340	3577	4500
			1750	23.3	5.176	11804	84	4.141	9443	3.451	7869					
			1160	15.5	3.726	12682	84	2.981	10146	2.484	8455					
			870	11.6	2.919	13138	83	2.335	10510	1.946	8759					
			600	8.0	2.109	13577	82	1.687	10862	1.406	9051					
			300	4.0	1.128	14081	79	0.902	11265	0.752	9387					
			100	1.3	0.428	14428	71	0.342	11542	0.285	9619					
75.9(H)	5.06	15	2500	32.9	6.451	10813	88	5.161	8650	4.301	7209	500	2800	3340	3577	4500
			1750	23.1	5.013	11834	86	4.010	9467	3.342	7889					
			1160	15.3	3.627	12704	85	2.902	10163	2.418	8469					
			870	11.5	2.848	13154	84	2.278	10523	1.899	8769					
			600	7.9	2.057	13588	83	1.646	10870	1.371	9059					
			300	4.0	1.091	14087	81	0.873	11270	0.727	9391					
			100	1.3	0.383	14430	79	0.306	11544	0.255	9620					
88.9(H)	5.93	15	2500	28.1	5.794	11301	87	4.635	9041	3.863	7534	500	2800	3340	3577	4500
			1750	19.7	4.444	12205	86	3.555	9764	2.963	8137					
			1160	13.0	3.181	12966	84	2.545	10373	2.121	8644					
			870	9.8	2.485	13358	83	1.988	10686	1.657	8905					
			600	6.7	1.785	13733	82	1.428	10986	1.190	9155					
			300	3.4	0.941	14162	81	0.753	11330	0.627	9441					
			100	1.1	0.33	14456	78	0.264	11565	0.220	9637					
100(D)	5	20	2500	25.0	5.191	10854	83	4.153	8683	3.461	7236	500	2800	3660	4046	4500
			1750	17.5	3.979	11801	82	3.183	9441	2.653	7867					
			1160	11.6	2.749	12148	81	2.199	9718	1.833	8099					
			870	8.7	2.077	12123	81	1.662	9698	1.385	8082					
			600	6.0	1.456	12144	79	1.165	9715	0.971	8096					
			300	3.0	0.75	12101	77	0.600	9681	0.500	8067					
			100	1.0	0.315	13717	69	0.252	10974	0.210	9145					
101.3(H)	5.06	20	2500	24.7	4.987	10890	86	3.990	8712	3.325	7260	500	2800	3660	4046	4500
			1750	17.3	3.853	11828	84	3.082	9462	2.569	7885					
			1160	11.5	2.676	12168	83	2.141	9734	1.784	8112					
			870	8.6	2.027	12138	82	1.622	9710	1.351	8092					
			600	5.9	1.413	12094	80	1.130	9675	0.942	8063					
			300	3.0	0.725	12106	79	0.580	9685	0.483	8071					
			100	1.0	0.282	13719	76	0.226	10975	0.188	9146					
118.6(H)	5.93	20	2500	21.1	4.466	11339	85	3.573	9071	2.977	7559	500	2800	3660	4046	4500
			1750	14.8	3.404	12152	84	2.723	9722	2.269	8101					
			1160	9.8	2.298	12155	82	1.838	9724	1.532	8103					
			870	7.3	1.741	12134	81	1.393	9707	1.161	8089					
			600	5.1	1.214	12099	80	0.971	9679	0.809	8066					
			300	2.5	0.622	12111	78	0.498	9689	0.415	8074					
			100	0.8	0.249	14057	76	0.199	11246	0.166	9371					

1. Exact ratio.
 2. If input speed is below 1160 RPM, please specify speed and mounting position to ensure proper lubrication.
 3. Overhung load given at a distance equal to one shaft diameter from the face of the output seal.
 4. Overhung load is based on maximum bore size. Use of smaller driven shaft diameter may limit OHL capacity.

5. Overhung loads are based on the output shaft and output bearing capacities only. Check Overhung Load Section for other considerations.
 6. Overhung load and thrust load ratings are computed independent of each other. For combined load applications, contact Winsmith.

Ratings



2D DRAWINGS & 3D MODELS
www.WINSMITH.com



DOUBLE REDUCTION

With Mobil Glygoyle 460 Lubricant



CENTER DISTANCE DOUBLE WORM HELICAL WORM		PRIMARY 2.625 3.200	SECONDARY 4.250 4.250	HORSEPOWER AND TORQUE RATINGS								OVERHUNG LOAD CAPACITIES (lb)			THRUST LOAD CAPACITIES (lb)		
OVERALL RATIO ¹	PRIMARY RATIO ¹	SECONDARY RATIO ¹	INPUT RPM ²	OUTPUT RPM	MECHANICAL								ALL SHAFT INPUT MODELS	OUTPUT SHAFT ^{5,6}		OUTPUT SHAFT ⁶	
					1.00 SERVICE FACTOR		1.25 SERVICE FACTOR		1.50 SERVICE FACTOR		SOLID ³ SHAFT (e.g. MDND)	HOLLOW ⁴ SHAFT (e.g. MDSD)		SOLID SHAFT (e.g. MDND)	HOLLOW SHAFT (e.g. MDSD)		
					INPUT HP	OUTPUT TORQUE (lbf-in.)	EFF	INPUT HP	OUTPUT TORQUE (lbf-in.)	INPUT HP						OUTPUT TORQUE (lbf-in.)	
150(D)	10	15	2500	16.7	4.073	12544	81	3.258	10035	2.715	8363	250	2800	3340	3577	4500	
			1750	11.7	2.99	13130	81	2.392	10504	1.993	8753						
			1160	7.7	2.075	13610	80	1.660	10888	1.383	9073						
			870	5.8	1.598	13852	80	1.278	11082	1.065	9235						
			600	4.0	1.135	14081	79	0.908	11265	0.757	9387						
			300	2.0	0.597	14341	76	0.478	11473	0.398	9561						
			100	0.7	0.235	14516	65	0.188	11613	0.157	9677						
151.9(H)	5.06	30	2500	16.5	3.533	11122	82	2.826	8898	2.355	7415	500	2800	4260	4200	4500	
			1750	11.5	2.783	12153	80	2.226	9722	1.855	8102						
			1160	7.6	2.059	13032	77	1.647	10426	1.373	8688						
			870	5.7	1.624	13486	75	1.299	10789	1.083	8991						
			600	4.0	1.179	13924	74	0.943	11139	0.786	9283						
			300	2.0	0.629	14426	72	0.503	11541	0.419	9617						
			100	0.7	0.223	14772	69	0.178	11818	0.149	9848						
177.9(H)	5.93	30	2500	14.1	3.188	11615	81	2.550	9292	2.125	7743	500	2800	4260	4200	4500	
			1750	9.8	2.491	12528	79	1.993	10022	1.661	8352						
			1160	6.5	1.81	13296	76	1.448	10637	1.207	8864						
			870	4.9	1.42	13691	75	1.136	10953	0.947	9127						
			600	3.4	1.025	14069	73	0.820	11255	0.683	9379						
			300	1.7	0.544	14502	71	0.435	11602	0.363	9668						
			100	0.6	0.192	14797	69	0.154	11838	0.128	9865						
200(D)	10	20	2500	12.5	3.037	12148	79	2.430	9718	2.025	8099	250	2800	3660	4046	4500	
			1750	8.8	2.127	12116	79	1.702	9693	1.418	8077						
			1160	5.8	1.426	12112	78	1.141	9690	0.951	8075						
			870	4.4	1.082	12142	77	0.866	9714	0.721	8095						
			600	3.0	0.754	12101	76	0.603	9681	0.503	8067						
			300	1.5	0.409	12706	74	0.327	10165	0.273	8471						
			100	0.5	0.177	14057	63	0.142	11246	0.118	9371						
202.5(H)	5.06	40	2500	12.4	2.638	10850	81	2.110	8680	1.759	7233	500	2800	4578	4200	4500	
			1750	8.6	2.069	11774	78	1.655	9419	1.379	7849						
			1160	5.7	1.519	12344	74	1.215	9875	1.013	8229						
			870	4.3	1.158	12311	72	0.926	9849	0.772	8207						
			600	3.0	0.816	12323	71	0.653	9858	0.544	8215						
			300	1.5	0.432	12644	69	0.346	10115	0.288	8429						
			100	0.5	0.165	13887	66	0.132	11110	0.110	9258						
253.2(H)	5.06	50	2500	9.9	1.813	9060	78	1.450	7248	1.209	6040	500	2800	4915	4200	4500	
			1750	6.9	1.318	9071	76	1.054	7257	0.879	6047						
			1160	4.6	0.927	9069	71	0.742	7255	0.618	6046						
			870	3.4	0.705	9030	70	0.564	7224	0.470	6020						
			600	2.4	0.496	9026	68	0.397	7221	0.331	6017						
			300	1.2	0.276	9720	66	0.221	7776	0.184	6480						
			100	0.4	0.111	11220	64	0.089	8976	0.074	7480						

1. Exact ratio.
 2. If input speed is below 1160 RPM, please specify speed and mounting position to ensure proper lubrication.
 3. Overhung load given at a distance equal to one shaft diameter from the face of the output seal.
 4. Overhung load is based on maximum bore size. Use of smaller driven shaft diameter may limit OHL capacity.

5. Overhung loads are based on the output shaft and output bearing capacities only. Check Overhung Load Section for other considerations.
 6. Overhung load and thrust load ratings are computed independent of each other. For combined load applications, contact Winsmith.

Ratings





DOUBLE REDUCTION

With Mobil Glygoyle 460 Lubricant

REDUCER SIZE

E43

CENTER DISTANCE DOUBLE WORM HELICAL WORM		PRIMARY 2.625 3.200	SECONDARY 4.250 4.250	HORSEPOWER AND TORQUE RATINGS								OVERHUNG LOAD CAPACITIES (lb)			THRUST LOAD CAPACITIES (lb)		
OVERALL RATIO ¹	PRIMARY RATIO ¹	SECONDARY RATIO ¹	INPUT RPM ²	OUTPUT RPM	MECHANICAL								ALL SHAFT INPUT MODELS	OUTPUT SHAFT ^{5,6}		OUTPUT SHAFT ⁶	
					1.00 SERVICE FACTOR		1.25 SERVICE FACTOR		1.50 SERVICE FACTOR		SOLID ³ SHAFT (e.g. MDND)	HOLLOW ⁴ SHAFT (e.g. MDSD)		SOLID SHAFT (e.g. MDND)	HOLLOW SHAFT (e.g. MDSD)		
					INPUT HP	OUTPUT TORQUE (lbf-in.)	EFF	INPUT HP	OUTPUT TORQUE (lbf-in.)	INPUT HP						OUTPUT TORQUE (lbf-in.)	
296.4(H)	5.93	50	2500	8.4	1.57	9051	77	1.256	7241	1.047	6034	500	2800	4915	4200	4500	
			1750	5.9	1.149	9075	74	0.919	7260	0.766	6050						
			1160	3.9	0.798	9049	70	0.638	7239	0.532	6033						
			870	2.9	0.607	9019	69	0.486	7215	0.405	6013						
			600	2.0	0.427	9024	68	0.342	7219	0.285	6016						
			300	1.0	0.242	9917	66	0.194	7934	0.161	6611						
			100	0.3	0.096	11353	63	0.077	9082	0.064	7569						
300(D)	20	15	2500	8.3	2.35	13535	76	1.880	10828	1.567	9023	275	2800	3340	3577	4500	
			1750	5.8	1.669	13848	77	1.335	11078	1.113	9232						
			1160	3.9	1.134	14099	76	0.907	11279	0.756	9399						
			870	2.9	0.862	14223	76	0.690	11378	0.575	9482						
			600	2.0	0.605	14341	75	0.484	11473	0.403	9561						
			300	1.0	0.315	14472	73	0.252	11578	0.210	9648						
			100	0.3	0.124	14561	62	0.099	11649	0.083	9707						
355.7(H)	5.93	60	2500	7.0	1.086	7242	74	0.869	5794	0.724	4828	500	2800	5210	4200	4500	
			1750	4.9	0.844	7718	71	0.675	6174	0.563	5145						
			1160	3.2	0.607	7993	68	0.486	6394	0.405	5329						
			870	2.4	0.463	7993	67	0.370	6394	0.309	5329						
			600	1.7	0.326	7993	66	0.261	6394	0.217	5329						
			300	0.8	0.168	7993	64	0.134	6394	0.112	5329						
			100	0.3	0.063	8698	61	0.050	6958	0.042	5799						
500(D)	20	25	2500	5.0	1.58	13974	70	1.264	11179	1.053	9316	275	2800	3950	4200	4500	
			1750	3.5	1.126	14299	71	0.901	11439	0.751	9533						
			1160	2.3	0.768	14561	70	0.614	11649	0.512	9707						
			870	1.7	0.586	14691	69	0.469	11753	0.391	9794						
			600	1.2	0.412	14813	69	0.330	11850	0.275	9875						
			300	0.6	0.215	14950	66	0.172	11960	0.143	9967						
			100	0.2	0.085	15042	56	0.068	12034	0.057	10028						
750(D)	25	30	2500	3.3	1.123	14079	66	0.898	11263	0.749	9386	275	2800	4260	4200	4500	
			1750	2.3	0.794	14334	67	0.635	11467	0.529	9556						
			1160	1.5	0.539	14538	66	0.431	11630	0.359	9692						
			870	1.2	0.409	14639	66	0.327	11711	0.273	9759						
			600	0.8	0.287	14734	65	0.230	11787	0.191	9823						
			300	0.4	0.15	14840	63	0.120	11872	0.100	9893						
			100	0.1	0.06	14912	53	0.048	11930	0.040	9941						
1000(D)	50	20	2500	2.5	0.738	12115	65	0.590	9692	0.492	8077	285	2800	3660	4046	4500	
			1750	1.8	0.514	12353	67	0.411	9882	0.343	8235						
			1160	1.2	0.364	13350	67	0.291	10680	0.243	8900						
			870	0.9	0.288	14018	67	0.230	11214	0.192	9345						
			600	0.6	0.2	14057	67	0.160	11246	0.133	9371						
			300	0.3	0.103	14057	65	0.082	11246	0.069	9371						
			100	0.1	0.042	14057	54	0.034	11246	0.028	9371						

Ratings

1. Exact ratio.
 2. If input speed is below 1160 RPM, please specify speed and mounting position to ensure proper lubrication.
 3. Overhung load given at a distance equal to one shaft diameter from the face of the output seal.
 4. Overhung load is based on maximum bore size. Use of smaller driven shaft diameter may limit OHL capacity.

5. Overhung loads are based on the output shaft and output bearing capacities only. Check Overhung Load Section for other considerations.
 6. Overhung load and thrust load ratings are computed independent of each other. For combined load applications, contact Winsmith.



2D DRAWINGS & 3D MODELS
www.WINSMITH.com



DOUBLE REDUCTION

With Mobil Glygoyle 460 Lubricant



CENTER DISTANCE DOUBLE WORM HELICAL WORM		PRIMARY 2.625 3.200	SECONDARY 4.250 4.250	HORSEPOWER AND TORQUE RATINGS								OVERHUNG LOAD CAPACITIES (lb)			THRUST LOAD CAPACITIES (lb)		
OVERALL RATIO ¹	PRIMARY RATIO ¹	SECONDARY RATIO ¹	INPUT RPM ²	OUTPUT RPM	MECHANICAL								ALL SHAFT INPUT MODELS	OUTPUT SHAFT ^{5,6}		OUTPUT SHAFT ⁶	
					1.00 SERVICE FACTOR		1.25 SERVICE FACTOR		1.50 SERVICE FACTOR		SOLID ³ SHAFT (e.g. MDND)	HOLLOW ⁴ SHAFT (e.g. MDSD)		SOLID SHAFT (e.g. MDND)	HOLLOW SHAFT (e.g. MDSD)		
					INPUT HP	OUTPUT TORQUE (lbf-in.)	EFF	INPUT HP	OUTPUT TORQUE (lbf-in.)	INPUT HP						OUTPUT TORQUE (lbf-in.)	
1500(D)	50	30	2500	1.7	0.676	14507	57	0.541	11606	0.451	9671	285	2800	4260	4200	4500	
			1750	1.2	0.459	14638	59	0.367	11710	0.306	9759						
			1160	0.8	0.301	14741	60	0.241	11793	0.201	9827						
			870	0.6	0.233	14793	59	0.186	11834	0.155	9862						
			600	0.4	0.168	14840	56	0.134	11872	0.112	9893						
			300	0.2	0.088	14894	54	0.070	11915	0.059	9929						
			100	0.1	0.033	14929	47	0.026	11943	0.022	9953						
2000(D)	50	40	2500	1.3	0.447	12844	57	0.358	10275	0.298	8563	285	2800	4578	4200	4500	
			1750	0.9	0.32	13427	58	0.256	10742	0.213	8951						
			1160	0.6	0.217	13887	59	0.174	11110	0.145	9258						
			870	0.4	0.164	13887	58	0.131	11110	0.109	9258						
			600	0.3	0.114	13887	58	0.091	11110	0.076	9258						
			300	0.2	0.059	13887	56	0.047	11110	0.039	9258						
			100	0.1	0.024	13887	46	0.019	11110	0.016	9258						
3000(D)	60	50	2500	0.8	0.254	10120	53	0.203	8096	0.169	6747	270	2800	4915	4200	4500	
			1750	0.6	0.185	10773	54	0.148	8618	0.123	7182						
			1160	0.4	0.129	11280	54	0.103	9024	0.086	7520						
			870	0.3	0.098	11426	53	0.078	9141	0.065	7617						
			600	0.2	0.068	11515	53	0.054	9212	0.045	7677						
			300	0.1	0.035	11724	52	0.028	9379	0.023	7816						
			100	-	0.014	11807	43	0.011	9446	0.009	7871						
3600(D)	60	60	2500	0.7	0.173	7993	51	0.138	6394	0.115	5329	270	2800	5210	4200	4500	
			1750	0.5	0.126	8508	52	0.101	6806	0.084	5672						
			1160	0.3	0.086	8686	52	0.069	6949	0.057	5791						
			870	0.2	0.065	8754	52	0.052	7003	0.043	5836						
			600	0.2	0.045	8820	52	0.036	7056	0.030	5880						
			300	0.1	0.023	8890	51	0.018	7112	0.015	5927						
			100	-	0.009	8908	42	0.007	7126	0.006	5939						
4000(D)	80	50	2500	0.6	0.233	10652	45	0.186	8522	0.155	7101	270	2800	4915	4200	4500	
			1750	0.4	0.168	11206	46	0.134	8965	0.112	7471						
			1160	0.3	0.109	11426	48	0.087	9141	0.073	7617						
			870	0.2	0.081	11509	49	0.065	9207	0.054	7673						
			600	0.2	0.056	11648	49	0.045	9318	0.037	7765						
			300	0.1	0.028	11733	49	0.022	9386	0.019	7822						
			100	-	0.012	11810	40	0.010	9448	0.008	7873						

1. Exact ratio.
 2. If input speed is below 1160 RPM, please specify speed and mounting position to ensure proper lubrication.
 3. Overhung load given at a distance equal to one shaft diameter from the face of the output seal.
 4. Overhung load is based on maximum bore size. Use of smaller driven shaft diameter may limit OHL capacity.

5. Overhung loads are based on the output shaft and output bearing capacities only. Check Overhung Load Section for other considerations.
 6. Overhung load and thrust load ratings are computed independent of each other. For combined load applications, contact Winsmith.

Ratings





DOUBLE REDUCTION

With Mobil Glygoyle 460 Lubricant

REDUCER SIZE

E43

CENTER DISTANCE DOUBLE WORM HELICAL WORM		PRIMARY 2.625 3.200	SECONDARY 4.250 4.250	HORSEPOWER AND TORQUE RATINGS								OVERHUNG LOAD CAPACITIES (lb)			THRUST LOAD CAPACITIES (lb)	
OVERALL RATIO ¹	PRIMARY RATIO ¹	SECONDARY RATIO ¹	INPUT RPM ²	OUTPUT RPM	MECHANICAL						ALL SHAFT INPUT MODELS	INPUT SHAFT		OUTPUT SHAFT ^{5,6}		
					1.00 SERVICE FACTOR	1.25 SERVICE FACTOR	1.50 SERVICE FACTOR	INPUT HP	OUTPUT TORQUE (lbf-in.)	EFF		INPUT HP	OUTPUT TORQUE (lbf-in.)	INPUT HP	OUTPUT TORQUE (lbf-in.)	SOLID ³ SHAFT (e.g. MDND)
5000(D)	100	50	2500	0.5	0.233	11074	38	0.186	8859	0.155	7383	270	2800	4915	4200	4500
			1750	0.4	0.154	11292	41	0.123	9034	0.103	7528					
			1160	0.2	0.098	11504	43	0.078	9203	0.065	7669					
			870	0.2	0.071	11581	45	0.057	9265	0.047	7721					
			600	0.1	0.049	11659	46	0.039	9327	0.033	7773					
			300	0.1	0.025	11797	45	0.020	9438	0.017	7865					
			100	-	0.01	11871	36	0.008	9497	0.007	7914					
6000(D)	100	60	2500	0.4	0.156	8571	36	0.125	6857	0.104	5714	270	2800	5210	4200	4500
			1750	0.3	0.102	8695	39	0.082	6956	0.068	5797					
			1160	0.2	0.064	8768	42	0.051	7014	0.043	5845					
			870	0.1	0.047	8827	43	0.038	7062	0.031	5885					
			600	0.1	0.032	8841	44	0.026	7073	0.021	5894					
			300	0.1	0.016	8901	44	0.013	7121	0.011	5934					
			100	-	0.007	8911	35	0.006	7129	0.005	5941					
8000(D)	100	80	2500	0.3	0.095	6560	34	0.076	5248	0.063	4373	270	2800	5231	4200	4500
			1750	0.2	0.061	6560	37	0.049	5248	0.041	4373					
			1160	0.1	0.038	6560	40	0.030	5248	0.025	4373					
			870	0.1	0.028	6560	41	0.022	5248	0.019	4373					
			600	0.1	0.019	6560	42	0.015	5248	0.013	4373					
			300	-	0.009	6560	42	0.007	5248	0.006	4373					
			100	-	0.004	6560	33	0.003	5248	0.003	4373					
10000(D)	100	100	2500	0.3	0.067	5529	33	0.054	4423	0.045	3686	270	2800	5231	4200	4500
			1750	0.2	0.043	5534	35	0.034	4427	0.029	3689					
			1160	0.1	0.027	5534	38	0.022	4427	0.018	3689					
			870	0.1	0.02	5534	39	0.016	4427	0.013	3689					
			600	0.1	0.013	5534	40	0.010	4427	0.009	3689					
			300	-	0.007	5534	40	0.006	4427	0.005	3689					
			100	-	0.003	5534	32	0.002	4427	0.002	3689					

1. Exact ratio.
 2. If input speed is below 1160 RPM, please specify speed and mounting position to ensure proper lubrication.
 3. Overhung load given at a distance equal to one shaft diameter from the face of the output seal.
 4. Overhung load is based on maximum bore size. Use of smaller driven shaft diameter may limit OHL capacity.

5. Overhung loads are based on the output shaft and output bearing capacities only. Check Overhung Load Section for other considerations.
 6. Overhung load and thrust load ratings are computed independent of each other. For combined load applications, contact Winsmith.

Ratings



2D DRAWINGS & 3D MODELS
www.WINSMITH.com



SE Encore Appendix

WINSMITH

SE Encore Appendix Table of Contents

SE Encore Worm Gear Speed Reducer Selection Criteria . . .	215
Service Life and Catalog Ratings	215
Speed Reducer Selection Methods	216
Overhung and Thrust Load Requirements	216
Output Speed and Gear Ratio Requirements	216
Ratio Selection	217
Product Configuration	217
Environmental Requirements	217
SE Encore Series Standard Ratios	218
SE Encore Series Selection Guide	219
Speed Reducer Sealing and Venting	220
Speed Reducer Self-Locking and Back-Driving	224
SE Encore Series Lubrication	226
SE Encore Series Overhung Load and Thrust	227
SE Encore Series Thermal Limit Ratings	229
Speed Reducer Backlash	230
Speed Reducer Efficiency and Run-in	232
Service Factor Section	233
Useful Formulas, Conversions, and Motor Mounting Dimensions	
Resource Guide and Conversion Tables	237
Useful Formulas	238
NEMA/IEC Frame Reference Dimensions	239
Speed Reducer Specification Sheet	240
Warnings and Cautions	243
Terms and Conditions of Sale	245
Winsmith History	246

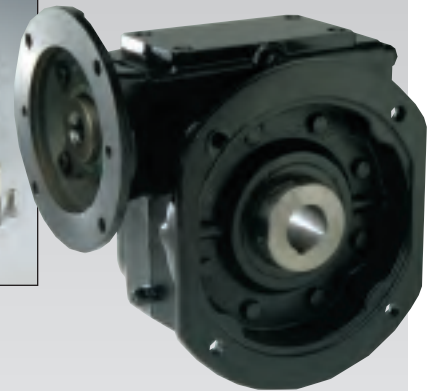
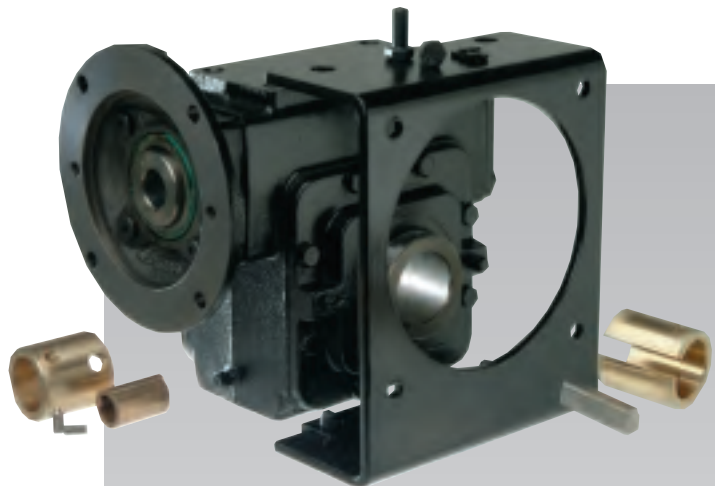

Appendix

SE Encore Worm Gear Speed Reducer Selection Criteria

When choosing an SE Encore speed reducer, a number of application issues require consideration. This section of the catalog assists with the selection of the optimal SE Encore worm gear speed reducer for an application. Proper reducer selection ensures desired operating results and long product life. The Selection Guide on page 219 employs a series of questions as a guide for this process. Each question includes referenced catalog pages that contain more detailed information.

Service Life and Catalog Ratings

Worm gear speed reducer ratings are based on a nominal service life when operated at the published levels. Nominal service life is defined by AGMA as 25,000 hours when the appropriate reducer service factor is selected, proper lubrication employed at installation, and appropriate maintenance practices are followed. If an application requires a nominal service life greater than 25,000 hours, a higher service factor should be used in the selection process. Contact Winsmith regarding the application and gearing configuration before employing service factors lower than 1.00 (a nominal service life of less than 25,000 hours). Intermittent duty applications with a high number of starts and stops can have a dramatic negative impact on the life of a worm gear speed reducer. Reference the Winsmith Motion Control Products catalog for additional information on the selection of intermittent duty reducers (available at www.WINSMITH.com).

Service Life

The nominal service life defined by AGMA is not a guarantee of the actual service life of any specific gear reducer, but is an average calculated life derived from industry formulas and other factors such as test results, proprietary calculations, and assumptions. These factors take into consideration the metal composition, the design of the gearing and bearings, as well as calculated loads. Service life calculations are not based on actual field conditions or applications, and do not represent a guarantee with respect to expected life, performance, or other characteristics of a gear reducer in any given application or use. The actual service life could vary substantially from the nominal service life.

Service life calculations apply only to the gearing and bearings. There are no service life calculations for other gear reducer components such as structural parts, seals, and lubricants.

Seals and lubricants are maintenance items; replacement cycles will vary with operating conditions. Regular inspections, followed by appropriate maintenance, are recommended.

Factors Affecting Service Life

In any given application, numerous factors can affect the service life of a speed reducer. Some of these include: overhung and thrust loads, environmental conditions, intermittent duty, and sealed vs. vented operation. These factors are discussed in further detail in this Appendix.

This appendix contains important information regarding Winsmith products, including selection, application, operation, and service factor information. Please review it and other available guidance carefully before selecting or recommending a gear reducer for any application.



SE Encore Worm Gear Speed Reducer Selection Criteria

Speed Reducer Selection Methods

There are two primary methods of choosing an SE Encore worm gear speed reducer when knowing the specific load requirements. When using either method, the first step is determining the application service factor using the tables on pages 233-235. Then, using the selection guides throughout this section, choose either of the following methods:

• Selection Method #1:

When the required output torque and the speed reduction between the input and output shaft speeds are known, the proper speed reducer can be selected using the appropriate ratio, service factor, and output torque information found in the ratings section.

• Selection Method #2:

When the available input horsepower and the speed reduction between the input and output shaft speeds are known, the proper speed reducer can be selected using the appropriate ratio, service factor, and output torque information found in the ratings section. Note that the speed reducer may be incorrectly sized (undersized or oversized) if the available input horsepower (motor) is used as the primary method for selection.

Selection Method #1: Speed Reducer Selection Procedure using Output Torque

When using the output torque for speed reducer selection, the applied output torque (output torque, lbf-in) and output speed (rpm) are requisites. The output torque is determined by the application requirements. The steps that follow help complete the selection of the optimal speed reducer:

1. Determine the service factor (S.F.) from the table on page 236 for the desired application and daily operating service duration.
2. Determine the design output torque (design output torque = applied output torque x S.F.).
3. Determine the speed reducer gear ratio or output speed (output rpm) required from the application (see page 218 for available standard ratios).

Selection Method #2: Speed Reducer Selection Procedure using Input Horsepower

When using the input horsepower for speed reducer selection, the applied input horsepower (input HP) and input speed (input rpm) are requisites. The input speed is typically constant and generated from an AC or DC motor. The steps that follow help complete the selection of the optimal speed reducer:

1. Determine the service factor (S.F.) from the table on page 236 for the desired application and daily operating service duration.
2. Determine the design input horsepower.
The design input horsepower = applied input horsepower x S.F.
3. Determine the speed reducer gear ratio or output speed (output rpm) required for the application (see page 218 for available standard ratios).

Overhung and Thrust Load Requirements

These loads are in addition to the transmitted torque and are applied either to the input or to the output shaft of a speed reducer. Most often, the driven equipment handles these loads. However, in a relatively small number of applications, they are great enough that the strength of the reducer components becomes a factor in speed reducer selection. If excess overhung or thrust loads are transmitted to the reducer, the service life could experience a significant decrease from the published catalog levels. Please refer to "Overhung Load and Thrust" on page 227 of this section.

Output Speed and Gear Ratio Requirements

Selecting the correct SE Encore speed reducer ratio is an important initial application criterion because it determines the operating output speed of the speed reducer and sets the parameters for output torque and input horsepower. The gear reduction ratio also affects the selection of the reducer configuration because their performance characteristics vary dependant upon the center distance and configuration of the reducer.

The SE Encore series of worm gear speed reducers are available in three gear reduction combinations, each having a unique range of gear ratios:

1. Single reduction worm,
2. Double reduction worm, and
3. Double reduction helical/worm

SE Encore Worm Gear Speed Reducer Selection Criteria

Some of the same gear ratios found in one combination will overlap with those of one or more of the other two combinations and they will each exhibit different performance characteristics (output torque, input horsepower capabilities, efficiencies, etc.). Before finalizing the speed reducer selection, check each overlapping ratio combination for the optimal performance characteristics (see Table on page 218 for a summary of standard ratios).

Ratio Selection

1. Determine the RPM of the prime mover (i.e. motor) that attaches to the speed reducer.
 - Fixed input speed. The standard operating speed of an AC induction motor (e.g., 1750 RPM for a 4 pole motor).
 - Variable speed motor and control input. Choose the ratio that satisfies the application requirements and speed reducer limitations at the highest motor speed (e.g., for a motor with a variable speed between 583 and 1750 RPM range, use 1750 RPM for ratio selection).
 - Non-motorized input. A combination of belts and sheaves, or similar separate speed control devices can be used as an input to a gear reducer.
2. Determining the output RPM required for the application is independent of the speed reducer selection process. There are a number of useful formulas on page 238, that assist with this determination.
3. $SPEED\ REDUCER\ RATIO = INPUT\ RPM / OUTPUT\ RPM$. Based on the previous calculations, select the speed reducer ratio that corresponds to the center distance (size) and configuration (single, double, or helical/worm) from the Table 1. Input horsepower and output torque ratings at 1750 rpm and 1.0 service factor are included as a reference guide.

Product Configuration

The SE Encore series of worm gear speed reducers offers a wide range of configurations to fit a variety of applications and design requirements. Achieving the most effective overall system performance requires consideration of the speed reducer configuration early in the design phase. Some important speed reducer configuration issues are:

1. Output shafts – solid or hollow
2. Speed reducer mounting – eleven standard types
3. Multiple reductions – worm or helical primary combined with a worm secondary

Environmental Requirements

Environmental conditions can decrease the service life of a speed reducer because they can cause deterioration of components such as shafts and seals. The WinGuard Epoxy Coating System encloses the entire SE Encore series of worm gear speed reducers offering significant protection from environmental elements.

However, there are some operating environments (i.e. outdoor, wash down, pharmaceutical, etc.) that require higher levels of contamination protection. Winsmith offers a number of worm gear speed reducer enhancements that address these conditions including stainless steel reducers and shafts, special seals, etc. Some of these special features are described in the Modified section of this catalog. For more detail, please visit www.WINSMITH.com and review our SE Maximizer Series product line.



SE Encore Series Standard Ratios



TABLE 1. SE ENCORE STANDARD RATIOS¹ (Listed within reducer size by single, double, and helical/worm reduction)

Reducer Ratio ¹	Ratings @1.0SF	REDUCER SIZE																				
		E13		E17		E20		E24			E26			E30			E35			E43		
		S	S	D	S	D	S	D	H	S	D	H	S	D	H	S	D	H	S	D	H	
5	In HP	1.39	2.69		3.70		5.89			7.70			10.87			15.82			25.16			
	Out Tq	238	462		639		1017			1334			1886			2738			4382			
7.5	In HP	1.05	2.06		2.84		4.54			5.93			8.59			12.55			19.39			
	Out Tq	266	525		723		1168			1533			2232			3252			5011			
10	In HP	0.86	1.64		2.24		3.67			4.82			7.11			10.27			15.84			
	Out Tq	284	554		769		1249			1650			2448			3515			5400			
15	In HP	0.62	1.15		1.59		2.71			3.42			5.07			7.51			11.63			
	Out Tq	295	568		794		1359			1724			2578			3804			5819			
20	In HP	0.42	0.94		1.24		2.11			2.64			3.95			5.73			9.16			
	Out Tq	257	604		806		1383			1745			2645			3821			6007			
25	In HP	0.41	0.70		1.01		1.61		1.97	2.17		2.61	3.24		3.21	4.71		3.21	7.50		11.01	
	Out Tq	304	547		803		1285		1718	1758		2266	2676		2751	3884		2728	5981		9309	
30	In HP	0.35	0.66		0.86		1.45		1.69	1.80		2.26	2.67		2.66	4.07		2.66	6.40		9.18	
	Out Tq	293	596		788		1360		1763	1712		2343	2586		2713	3943		2702	6013		9063	
40	In HP	0.27	0.52		0.68		1.11		1.39	1.42		2.00	2.08		3.10	3.04		3.21	4.94		8.36	
	Out Tq	276	603		795		1335		1812	1737		2596	2617		3993	3837		4100	6005		10417	
50	In HP	0.17	0.41	0.487	0.56	0.727	0.92	1.148	0.821	1.18	1.491	1.146	1.72	1.873	1.792	2.44	3.109	3.215	3.96	7.019	6.798	
	Out Tq	213	558	781	791	1166	1329	1859	1404	1748	2391	1954	2643	3017	3024	3753	4992	5419	5852	11058	11087	
60	In HP	0.15	0.27		0.41		0.70		0.67	0.92		0.92	1.72		1.48	2.00		2.24	3.23		6.02	
	Out Tq	202	417		656		1134		1358	1556		1860	2033		2962	3573		4494	5566		11444	
75	In HP			0.258		0.364		0.618	0.586		0.831	0.789		1.301	1.244		2.883	2.756		5.176	5.013	
	Out Tq			593		845		1476	1479		1985	1988		3111	3116		6891	6906		11804	11834	
80	In HP		0.16		0.22		0.38			0.49			0.71			1.12			1.91			
	Out Tq		311		437		735			979			1478			2403			4114			
90	In HP								0.49			0.67			1.07			2.37			4.44	
	Out Tq								1466			2006			3179			7088			12205	
100	In HP		0.221		0.304		0.490	0.465		0.617	0.585		0.974	0.931		2.123	2.032		3.979	3.853		
	Out Tq		671		930		1543	1547		1941	1944		3067	3071		6708	6728		11801	11828		
120	In HP								0.365			0.499			0.799			1.514			3.404	
	Out Tq								1445			1975			3128			5952			12152	
150	In HP		0.135		0.199		0.334	0.307		0.464	0.418		0.750	0.663		1.647	1.461		2.990	2.783		
	Out Tq		596		881		1513	1480		2076	2028		3307	3201		7461	7092		13130	12153		
180	In HP								0.261			0.357			0.570			1.177			2.491	
	Out Tq								1503			2063			3263			6787			12528	
200	In HP		0.113		0.155		0.253	0.227		0.346	0.338		0.561	0.529		1.101	1.062		2.127	2.069		
	Out Tq		652		900		1504	1414		2038	2142		3243	3347		6558	6770		12116	11774		
250	In HP								0.194			0.263			0.418			0.670			1.318	
	Out Tq								1485			2035			3241			5196			9071	
300	In HP		0.078		0.116		0.190	0.151		0.266	0.203		0.418	0.323		0.949	0.563		1.149	1.669		
	Out Tq		607		899		1551	1363		2132	1853		3409	2940		7763	5181		9075	13848		
365	In HP								0.120			0.162			0.256			0.404			0.844	
	Out Tq								1256			1715			2721			4339			7718	
500	In HP		0.053		0.074		0.124			0.169			0.261			0.508			1.126			
	Out Tq		650		893		1527			2099			3354			6473			14299			
750	In HP		0.037		0.062		0.090			0.128			0.197			0.410			0.794			
	Out Tq		659		1088		1596			2200			3513			7442			14334			
1000	In HP		0.033		0.047		0.071			0.096			0.148			0.289			0.514			
	Out Tq		655		900		1541			2120			3392			6566			12353			
1500	In HP		0.022		0.037		0.052			0.074			0.113			0.244			0.459			
	Out Tq		664		1097		1611			2223			3555			7558			14638			
2000	In HP		0.020		0.028		0.038			0.054			0.083			0.184			0.320			
	Out Tq		727		1007		1530			2109			3369			7345			13427			
3000	In HP		0.015		0.021		0.028			0.040			0.059			0.118			0.185			
	Out Tq		749		1070		1445			1976			3164			6305			10773			
3600	In HP		0.010		0.016		0.025			0.036			0.049			0.080			0.126			
	Out Tq		581		893		1508			2054			3080			4954			8508			
4000	In HP		0.007		0.009		0.025			0.036			0.054			0.112			0.168			
	Out Tq		422		596		1447			1979			3171			6518			11206			
5000	In HP		0.006		0.008		0.023			0.034			0.050			0.103			0.154			
	Out Tq		423		597		1449			1982			3175			6563			11292			
6000	In HP		0.004		0.006		0.021			0.031			0.042			0.068			0.102			
	Out Tq		303		481		1524			2081			3123			5028			8695			
8000	In HP						0.011			0.017			0.022			0.041			0.061			
	Out Tq						988			1395			2050			3828			6560			
10000	In HP						0.008			0.011			0.015			0.027			0.043			
	Out Tq						818			1145			1696			2948			5534			

	Single Reduction
	Double Reduction
	Helical/Worm Reduction

- Special ratios and gearing are listed in the Modified section on page 133.
- Exact ratios are listed in the Ratings section starting on page 157.
- See page 229 for thermal limits of some ratings during continuous duty operation.
All ratings are for 1750 rpm

Appendix



SE Encore Series Selection Guide

Elements of Selection Process	Reference Section
Output speed Output speed required _____ RPM Ratio required _____:1 Reduction method -Single worm ____, Double/ worm ____, Helical/ worm ____	Ratio selection – page 133 & 218
Application service factor Length of daily service _____ hours Planned starts and stops a day _____ Emergency stop requirements - describe _____ Type of equipment being driven _____	Service factor – pages 233-236
Load	Rating selection – pages 157-213
Using input HP requirements method Input shaft configuration - separate style Input HP _____ Input speed to the gearbox _____ RPM	HP & torque selection – page 216
NEMA AC & DC motors Motor HP _____ Motor speed or variable speed range _____ to _____ RPM	NEMA motors – page 239
Servo motors - constant and variable speed applications only (Intermittent duty cycles see Winsmith Motion Control Catalog 400) Motor torque rating _____ in lbs Motor speed range _____ to _____ RPM Maximum operating speed for application _____ RPM	lbf-in
Using output torque requirements method Output torque requirements Torque required to move the load _____ in lbs Torque required to start moving the load _____ in lbs	HP & torque selection – page 216 lbf-in lbf-in
Overhung and Thrust Load	Overhung & thrust load – page 216
Output shaft overhung load Amount of overhung load applied _____ lbs Distance from the center of the housing where overhung load is applied _____ in.	
Input shaft overhung load Input shaft overhung load _____ lbs	lbs
Output thrust load Amount of thrust load _____ lbs	
Configuration	
Output configuration requirements Output configuration - single reduction or last stage of a multiple reduction gearbox Type of output shaft - solid _____ hollow _____ If hollow what is the bore size _____ Connection to the driven machine Footless (no base) _____ With feet (base) _____ Flange _____ Direction of the output shaft extension looking into the input Right _____ Left _____ Right & Left _____ Position of the input shaft to output shaft Above _____ Below _____ Special output shaft requirements _____	Model quick selection – page: • 32-35 • 68-71 • 86-89
Input configuration requirements Shaft input method – solid shaft Connection method _____ (ie: belt and pulley, coupling) Connection equipment description _____ Electric motor - AC/DC Quill or coupling _____ Motor frame size or specification _____ Servo motor Quill or coupling _____ Motor frame size or specification _____ Other types of input contact the factory	Model quick selection – page: • 32-35 • 68-71 • 86-89 Motor dimension – page 239 May require motor interface drawing
Mounting and Lubrication SE ENCORE product is lifetime lubricated	See product sections for further information
Environmental	
Environmental operating conditions For indoor dry applications _____ Range of ambient operating temperature _____ to _____ degrees F For indoor wet applications _____ For outdoor applications _____	Use standard SE Encore Lubrication section Use SE Maximizer products Use SE Maximizer products

When this Selection Guide is done go to the Product Nomenclature section on page 4 and complete the unit selection process.



2D DRAWINGS & 3D MODELS
www.WINSMITH.com



Speed Reducer Sealing and Venting

Sealed vs. Vented Speed Reducer Operation

All SE Encore series speed reducers are designed to operate sealed or vented. Deciding whether a speed reducer should operate sealed or vented requires an understanding of the application, the environment, the operation of radial shaft seals, and a review of the fundamentals of thermodynamics that govern the temperature and pressure relationship in the speed reducer.

Any significant increase in pressure in a sealed speed reducer decreases the operational service life of the radial lip seals. A pressure change of only 5 psi may reduce the seal life by as much as one third. There are two important phenomena that cause an increase in the internal pressure of a sealed speed reducer. First, the change of internal pressure during operation is proportional to the change of internal temperature

that occurs during normal operation. The relationship follows the combined gas law expressed as $P_1V_1 / T_1 = P_2V_2 / T_2$. Secondly, radial lip seals can ingest or "pump" air into a speed reducer regardless of whether it is operating sealed or vented. While the rate of ingestion is highly variable and dependant on running time and speed, under continuous operating conditions the net effect of "pumped" air to the total pressure increase is significant. *Venting, or the use of a breather vent, is the only absolute method of eliminating the pressure increase in a speed reducer caused by the increased operating temperature.*

In some applications, the duty cycle of the speed reducer is intermittent, the run times short, and the temperature increase modest. While sealing the reducer during operation subsequently increases the pressure

Pressure Increase in a Sealed Speed Reducer (Combined Effect of Lubricant and Air Expansion)

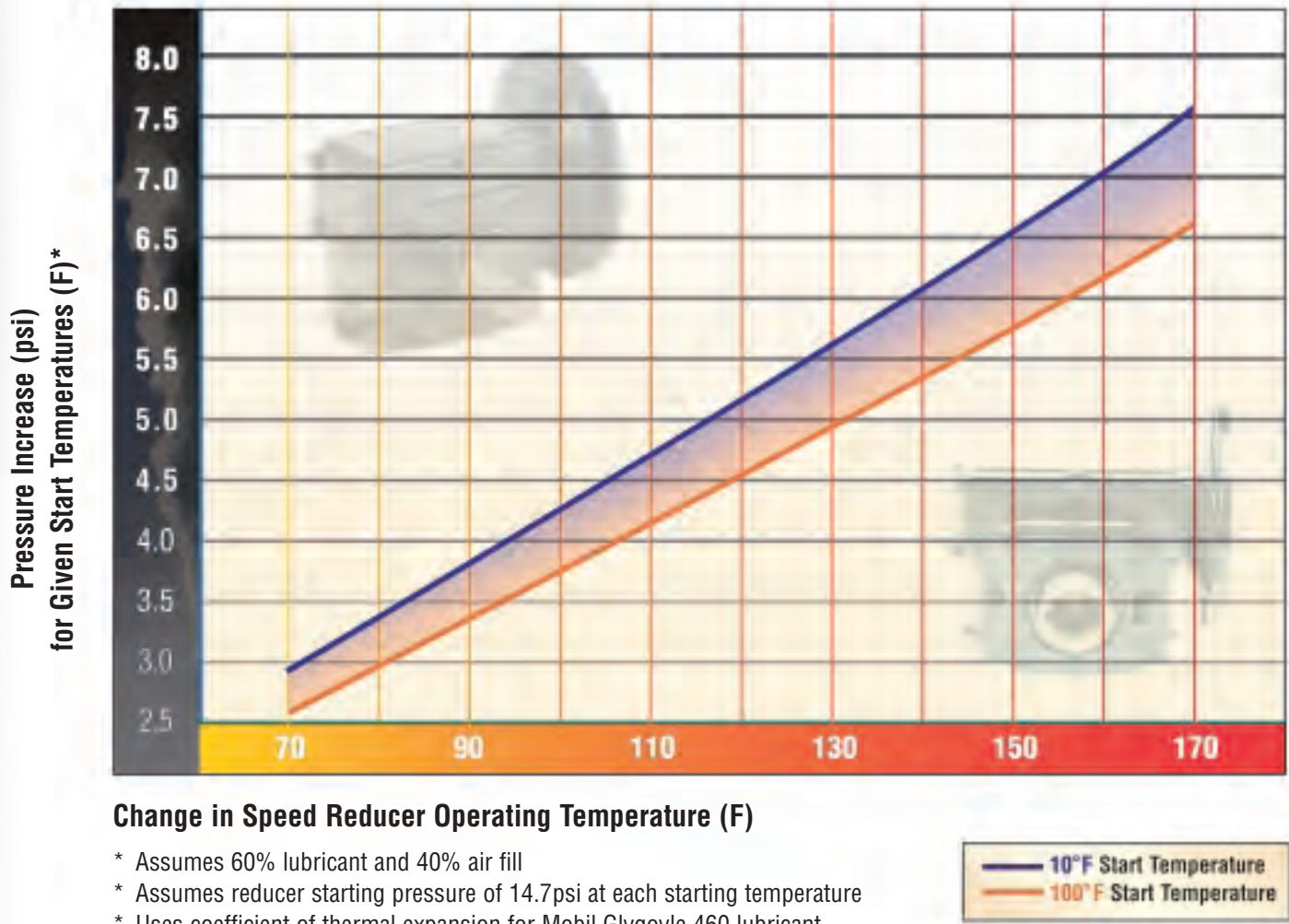

Figure 1.

Speed Reducer Sealing and Venting

in these applications, the increase may be very small and therefore have minimal impact on the seal service life. Additionally, operating a sealed speed reducer may be the best choice in applications where external airborne contamination causes a greater reduction in overall speed reducer service life than the negative impact of the internal pressure increase. The machine builder or the end equipment user should determine whether sealing or venting the speed reducer is the best choice for a specific application as this decision has a direct impact on the seal service life. The following section details the factors influencing seal life.

Internal Temperature and Pressure Increase in a Sealed Speed Reducer

A speed reducer experiences a significant internal temperature increase due to operating loads. The change in temperature of an operating speed reducer (from static ambient temperature to maximum operating temperature) often exceeds 130° Fahrenheit. In a sealed speed reducer, the increasing temperature results in a corresponding pressure increase as described by the combined gas law:

$$P_1V_1 / T_1 = P_2V_2 / T_2$$

In a closed system (e.g. sealed reducer), any change in temperature from one state of equilibrium to the next state of equilibrium results in a corresponding change in both oil volume and internal pressure. Moreover, the thermal expansion of the lubricant in the reducer can have a considerable effect on the pressure, temperature, and volume relationship. The influence of the lubricant's thermal expansion depends on the percent volume occupied by the lubricant compared to that of the air. Typically, the volume inside the reducer is about 60% lubricant and 40% air. The thermal expansion of the lubricant alone increases the internal pressure in the reducer by approximately 1.5 psi when the change in temperature is 130°F.

Figure 1 shows the total impact of the internal temperature and associated pressure increase at different ambient starting temperatures in a sealed speed reducer. Pressure increases greater than 5 psi can result from the combined effect of the lubricant's thermal expansion and the internal temperature change.

Seal "Pumping" Effects on Increased Pressure in an Operating Speed Reducer

Correctly operating radial shaft lip seals are dynamic and require the presence of a microscopically thin film

of lubricant directly under the sealing lip. The seal lip imposes shear forces on the film as the shaft rotates beneath it. This creates a seal "pumping action" that circulates the lubricant residing closest to the seal back inside the speed reducer and away from the external environment. The pumping action of the seal prevents the lubricant from seeping out and is necessary for proper operation. Unfortunately, a correctly functioning radial shaft seal also causes an unintended and unavoidable side effect. Tests confirm that microscopic air bubbles and contaminants from the external environment are entrained in the lubricant. The actively pumping seal sweeps them inward with the induced lubricant flow and once inside, they escape into the speed reducer. With continuous operation, the air bubbles accumulate inside the reducer cavity. The seal is acting as an air pump, causing air ingestion that increases the internal pressure of a sealed speed reducer. Winsmith's extensive testing has verified that the increased internal pressure of the speed reducer and the rate of pressurization are dependent on many variables including operating time, linear velocity of the shaft under the seal, temperature, seal material, and seal and shaft manufacturing tolerances.

In summary, a significantly large percentage of sealed speed reducers develop an internal pressure of 5 psi or more when operated on a continuous duty cycle. This phenomenon can occur even when there is no change in temperature because the radial lip seals ingest air into the reducer (see Figure 2). Conversely, testing indicates that when a reducer operates in an intermittent manner (e.g. 5 minutes of run time every 30 minutes of dwell), the internal pressure build-up is very small.

The Effects of Temperature and Pressure on Seal Operating Life

The specific failure mechanisms of seals vary depending on the seal material. However, the normal "wear out" failure mode of an NBR rubber (Acrylonitrile-butadiene or "nitrile") dynamic radial shaft seal is related to time and temperature and often termed "embrittlement." Over time under some relative elevation of temperature, nitrile seals lose elasticity, develop micro cracks that cause an abraded sealing surface that can no longer properly contain the speed reducer lubricant. The embrittlement rate of NBR materials begins to accelerate at lip operating temperatures between 180°F and 200°F.



Speed Reducer Sealing and Venting

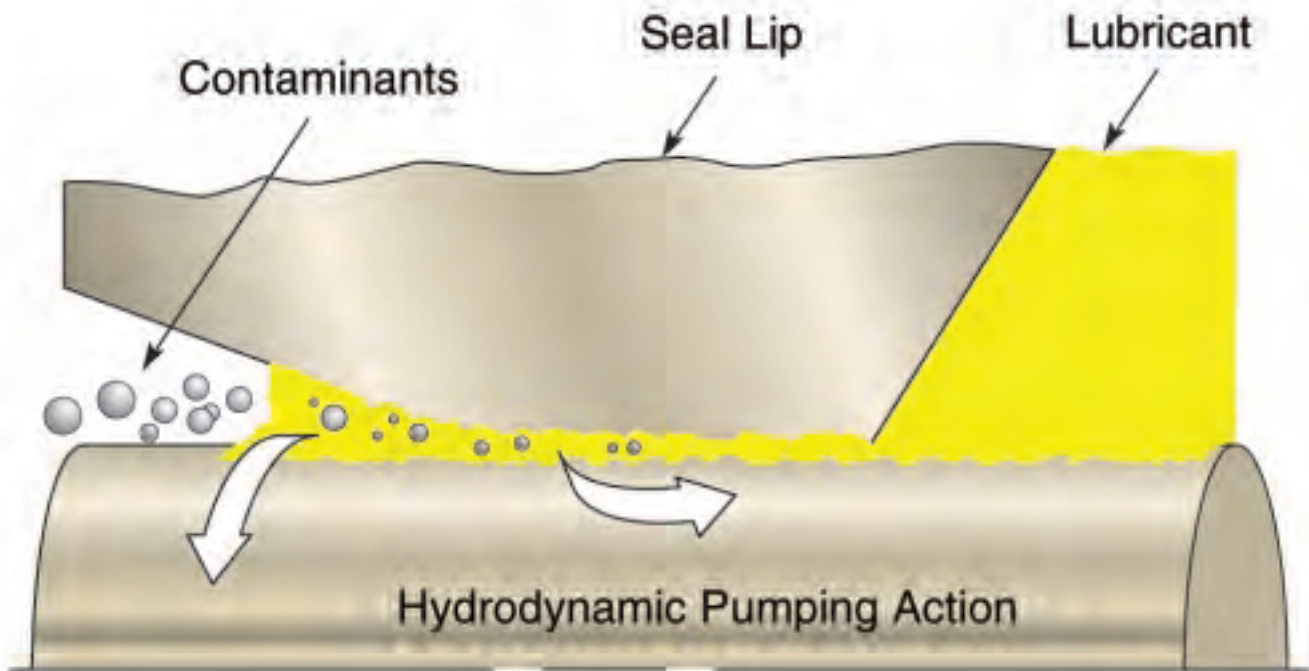

Figure 2. Ingestion of Air and Contaminant by a Radial Seal Courtesy of Parker Hannifin Corporation

The impact of increasing temperature and pressure in a sealed speed reducer on the service life of an NBR seal has been assessed by numerous seal manufacturers. While the results of these tests vary depending on variables such as the actual seal lip temperature, they indicate that a change in pressure as small as 5 psi can reduce the expected seal service life by one third. This is because a positive internal pressure differential in a speed reducer causes the shaft lip seals to exert a higher radial force on the shaft. Under dynamic conditions, this force increases the lip seal contact area on the shaft, increasing the friction, and thereby creating a correspondingly higher temperature between the shaft and the lip seal. This increase is directly proportional to the amount of radial force on the seal and to the speed of the shaft at the seal interface and causes a decrease in the seal life.

All SE Encore speed reducers with a quill input adaptor use special HNBR (hydrogenated nitrile butadiene rubber) or fluoroelastomer (aka Viton®) materials on all input shafts because these materials are tolerant of higher lip operating temperatures. The typical failure mode of HNBR material is blistering at the seal surface.

Performance Issues with Bladders and Expansion Chambers

Various speed reducer design approaches aimed at eliminating the internal pressure increase have incorporated internal collapsible diaphragms or bladders. Eliminating the pressure increase requires that the bladder or diaphragm collapse at very low pressures and have a volume that sufficiently accommodates the expansion of the air and the lubricant. In a reducer with a two inch center distance, the internal volume is between 30 in³ and 40 in³. Assuming the volume is 60% lubricant and 40% air and applying the previously discussed combined gas law over a temperature change of 130°F (70°F start, 200°F final), the size of an internal diaphragm or bladder required to prevent a pressure increase must be between 3.9 in³ and 5.2 in³. In most typical speed reducers, there is insufficient internal space for such a large bladder. Moreover, while some internal expansion chambers are effective in limiting or reducing internal pressure rise due to temperature changes, *none are completely effective in avoiding the pressure build up related to seal air pumping action associated with continuous duty cycle applications.*

Speed Reducer Sealing and Venting

Applications Determine When Sealing a Speed Reducer is Preferred to Venting

As covered in the preceding discussion, sealing a reducer can increase the internal pressure which results in decreased seal service life. This is especially prevalent when operating under continuous duty conditions. However, there are certain applications where the speed reducer duty cycle is highly intermittent, and run times are short with light average duty loads. Testing and field experience indicate that small internal pressure increases (1 – 2 psi) have a minimal effect on the seal service life.

Another application dependent situation where sealed reducer operation is preferred occurs when the external air environment is extremely contaminated with material that, if drawn into the reducer through a vent, can rapidly reduce seal, bearing, or worm gear life. In these applications, the increased pressure resulting from operating a sealed reducer can still have a significantly negative effect on seal life and, in these cases, require more frequent seal replacement. However, the reducer life may be lengthened by operating sealed rather than operating with an open vent in these types of harsh environments. Further, the machine builder or equipment operator might determine that the convenience of operating a sealed speed reducer outweighs the negative result of reduced seal service life. *The Winsmith two (2) year warranty on defect in parts and workmanship remains unaffected whether an SE Encore worm gear speed reducer operates with or without a vent since the vent/sealed decision only affects the service life of the speed reducer wear components.*

In conclusion, there are three fundamental factors that govern the speed reducer seal/vent decision. First, as the temperature increases in a sealed reducer, so will the pressure. Second, the radial shaft seals are designed to “pump” lubricant back into the speed reducer. This pumping action also causes an ingestion of air that increases the internal pressure. Any increase of pressure causes decreased dynamic radial seal life. Venting is the most cost effective method of eliminating the pressure. Finally, when extreme environmental conditions cause component or seal wear in excess of that caused by an increased internal pressure, sealing a speed reducer is the best likely alternative. However, under these conditions, seal wear is apt to take place at higher than predicted rates.

SE Encore Venting Solution is a Standard Feature

The SE Encore worm gear speed reducer series can satisfactorily operate sealed or vented. Each reducer is supplied with an optional “open-closed vent” that can be installed by the equipment builder or the equipment user. This exclusive Winsmith vent is made from black DuPont™ Zytel® Nylon with UV protection. The vent’s design incorporates a labyrinth with a dust/splash cap that minimizes contaminate and water incursion from the external environment created by general, harsh, and outdoor applications. The reducer housing offers multiple locations for vent installation depending on the final reducer mounting position on the equipment. Turning the top cap to the closed position ensures that no oil drains while the equipment is in transit to the operating location. Turning the top cap counter clockwise, by hand, opens the vent prior to running the speed reducer. A special screw driver slot molded into the cap allows easy actuation when access is limited. The vent should be installed in the highest pipe plug location available based on the actual mounting orientation of the speed reducer on the operating equipment. Additionally, a bright yellow plastic tag is provided with the vent that reads:

“IMPORTANT – VENT REQUIRES ACTIVATION THIS UNIT HAS BEEN SHIPPED TO YOU WITH THE VENT IN THE CLOSED POSITION – IT IS IMPORTANT TO OPEN THE VENT BY MAKING A ONE QUARTER TURN COUNTER CLOCKWISE”

DuPont™, Zytel®, and Viton® are registered trademarks of E. I. du Pont de Nemours and Company



Speed Reducer Self-Locking and Back-Driving

What is Self-Locking and Back-Driving?

The term self-locking, when applied to the operational performance characteristics of worm gear speed reducers, is defined as follows:

When an external load applies a dynamic or static torque to the output worm gear shaft, and this torque does not result in any rotation of the input worm, the reducer is considered self-locking.

Conversely, back-driving is the opposite effect and is defined as follows:

Back-driving occurs when an external load applies a dynamic or static torque to the output shaft and this torque does result in rotation of the input worm.

Depending on several design and load characteristics, worm gear speed reducers may be selected which either self-lock or back-drive and in some limited cases can do both depending on external loads and operational conditions. In most normal applications of a worm gear speed reducer, the input worm shaft is powered by an electric motor capable of applying a defined amount of speed and torque. This applied input torque is then amplified by the worm gear ratio while the speed is reduced proportionally. The amplified torque at the gear output shaft is then applied to the external load to perform the desired work.

It is important to note that there are some applications where the load characteristics cause a reversal of this normal flow of power from the input to the output of the speed reducer. This would apply where the reducer is being used as a worm gear speed increaser. Examples also include a worm gear speed reducer used on an overhead crane or vertical lift. Unless perfectly counter balanced a crane normally consumes input power during lifting operations, however when it is desired to lower the load, the load will apply a reverse torque to the output gear shaft as the load attempts to rapidly descend under the force of gravity. To prevent an undesired rapid decent of a vertical crane load it is required that the worm gear speed reducer absorbs power and provide a braking or reverse torque to the load. This kind of application is often referred to as an overhauling load.

Another overhauling application would be where a high inertia load is required to rapidly decelerate faster than friction forces alone would cause to occur. In this situation, as with many crane loads, it is desired that the speed reducer output smoothly apply a braking or reverse torque to the load in order to achieve desired operation.

Self-Locking:

Certain worm gear speed reducers have worm and gear geometries that prohibit dynamic reverse torque operation. Any torque reversal on the output shaft will cause the worm gear mesh to instantly lock up and the reducer will refuse to rotate. Great damage to perhaps both the worm gear speed reducer and the load may be the result when a gear mesh instantly locks up. Inherent characteristics in certain worm gear designs allow the reducer to immediately lock up the worm and gear mesh in reverse torque applications.

The causes of "lock up" behavior are complex. All worm gear designs exhibit components of both sliding and rolling friction in the worm thread and gear tooth mesh. When the friction component in the gear mesh reaches a critical amount, self locking can be the result. Many factors determine when this critical amount of mesh friction occurs, these include: the worm lead angle; the rotational speed; the reduction ratio; the type of gear tooth geometry used; gear and worm surface finish and hardness; temperature; the type and condition of the lubricant; the magnitude and frequency of any external vibration forces; any load pulsations; and the magnitude of the overhauling load.

Often, in a specific application, the point at which a particular self locking worm gear speed reducer actually locks up when static will be different than when it locks up dynamically. Specifically, selected self locking worm gear speed reducers may not dynamically self lock, but rather will freely back drive dynamically. However, this same reducer, once all rotation ceases, and it is stationary for some time, the reducer will self lock; even when a great deal of torque is applied to the output shaft. The result is that smooth acceptable operation with an overhauling load occurs when the reducer is running but once the reducer is stopped, it will not permit any rotation. In these situations the worm gear speed reducer is operating similar to the function provided by a static load brake.

Winsmith does not recommend or approve of the use of any worm gear speed reducer in any application where operational self-locking characteristics are used to replace a static or dynamic brake. Neither dynamic nor static self-locking performance of a worm gear speed reducer should ever be relied upon whenever any unintended load rotation might possibly result in damage or harm to either machinery or people. Self-locking Winsmith worm gear speed reducers should never be used to provide the function of a "fail safe" brake.

Speed Reducer Self-Locking and Back-Driving

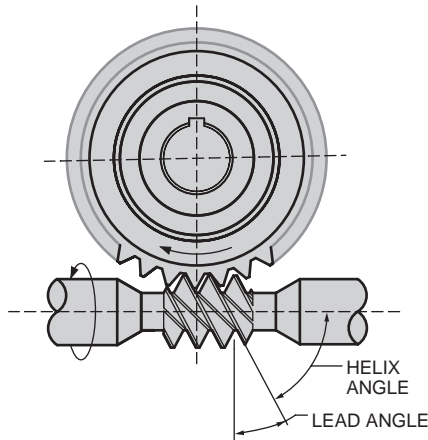

Figure 1.

When is a worm gear reducer considered to be Self-Locking?

Statically self-locking worm gear speed reducers can be obtained when the lead angle (Figure 1 above) of the worm threads is less than the sliding static friction angle (Figure 2 above) of the worm and gear. The sliding static friction angle of any two components is the angle at which, in Figure 2 above, the stationary block just starts to slide down the ramp shown. This angle is a primary function of the materials used to make the components and any lubricant applied at the sliding surfaces. For a bronze gear and a hardened steel worm operated in a typical worm gear speed reducer, the sliding static friction angle is generally assumed to be less than around eight (8) degrees. The sliding static friction angle may be lower than eight (8) degrees due to factors such as; surface finish, type of lubricant, condition of lubrication at the surfaces, and the presence of external vibration or load pulsations. After a reducer has run-in, the gear teeth become polished and thus the coefficient of friction angle is reduced. When static self locking is desired in an application, consideration must be given to the many factors including even the normal manufacturing tolerances that create variations in the lead angle of any specific worm or gear component part number.

The sliding dynamic friction angle is the angle, in Figure 2, where even when the block is in motion it will almost cease moving down the ramp. Under dynamic or rotating conditions of a worm and gear set, the sliding dynamic friction angle of the worm and gear is dependent on all the above discussed factors plus additionally it is a function of the rotational speed and the dynamic lubrication performance. For a bronze gear and a hardened steel worm operated in a typical worm gear speed reducer, the sliding dynamic friction angle is generally assumed to be less than around

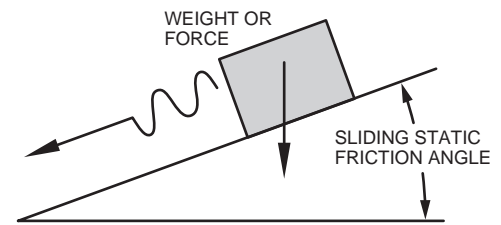

Figure 2.

2 degrees. If a worm gear reducer is selected with a worm thread lead angle of less than about 2 degrees it will normally dynamically self-lock. This means that whenever an external output load begins to overhaul or back drive the gear reducer, an abrupt immediate gear mesh lock-up or an intermittent or momentary lock-up is likely to occur. This almost always will result in serious, and perhaps permanent, damage to the worm gear speed reducer and perhaps also damage the driven load or machinery.

When a worm gear speed reducer is selected with a worm lead angle between a static sliding friction angle of about 8 degrees and a sliding dynamic friction angle of about 2 degrees, the reducer may exhibit both static self-locking, and at the same time, dynamic back-driving characteristics. The above operational characteristic of selected worm gear speed reducers may be extremely desirable in many applications where dynamic braking and static locking are desired. However, great care and prototype testing may be necessary in order to insure that the desired performance is achieved in a specific application. When the lead angle on worm threads is below 8 degrees, intermittent or momentary dynamic self-locking may also occur. When this occurs it is sometime times referred as "stick-slip" or "stair-stepping" operation and is generally undesirable and destructive.

NOTE:

The lead angles of the SE Encore Series were designed intentionally high for improved worm gear mesh power transfer efficiency. Depending on center distance, some sizes will have a tendency to be statically self-locking at 30:1 ratio and other sizes may not statically self lock at ratios as high as even 50:1. However, many special worm and gear ratio geometries are available to address various operational performance desires. Lead angles are not published, check with Winsmith for applications assistance.



SE Encore Series Lubrication

Mobil Glygoyle 460 Lubricant

Winsmith lubricates the entire SE Encore worm gear speed reducer series exclusively with Mobil Glygoyle® 460. In worm gear speed reducers, this advanced technology polyalkylene glycol (PAG) based synthetic oil provides exceptional performance properties and features including:

- improved efficiency
- lower operating temperatures
- high thermal and oxidative stability
- low deposit formation and sludge resistance
- excellent lubricity
- hydrolytic stability
- NSF H1 (formerly USDA) certified for incidental food contact

Lower Operating Temperatures

The improved SE Encore speed reducer efficiencies that result from Mobil Glygoyle 460 lubricant translate into lower operating temperatures. Testing has indicated that efficiency losses are decreased up to 20% when compared to polyalphaolefins (PAO) based synthetic lubricants and up to 35% when compared to standard 600W (mineral oil) worm gear lubrication (depending on the gear ratio). Additionally, this testing showed a 20°F lower operating temperature in a worm gear speed reducer using Mobil Glygoyle 460 when compared to that using a comparable PAO (Mobil SHC 634) lubricant at the same loaded condition. Further, the speed reducer with Mobil Glygoyle 460 operated several degrees cooler than that using another widely promoted competitive PAG based lubricant. A “rule of thumb” (valid within certain temperature ranges) is that oil and seal life double approximately every 18°F reduction in operating temperature. Therefore, the use of Mobil Glygoyle 460 lubricant in all SE Encore series worm gear speed reducers may double the lubricant and seal life in some applications.

Mixing of Lubricants

The PAG based stocks used in Mobil Glygoyle 460 do not chemically react with mineral or PAO lubricants and are not miscible. If they are mixed, an emulsion will form that will not provide proper lubrication. Therefore, care should be taken not to mix these incompatible lubricants. When switching from one lubricant type to another in a speed reducer, follow the instructions related to flushing procedures. This publication is available at www.WINSMITH.com.

Dependent on operating environment, a vented speed reducer may be subjected to lubricant contamination from external water or moisture. Hydrolytic stability is a

measure of the lubricant's tendency to chemically react and breakdown in the presence of water. Unlike PAO based synthetic lubricants, PAG based lubricants do not break down and lose their lubricity in the presence of water. However, water concentrations above about 1% should be avoided due the potential of internal corrosion.

Lubricant Level and Mounting Position

Winsmith fills all SE Encore Multimount series worm gear speed reducers to an oil level that allows mounting in any position. This also applies to all MDNS (quill input adaptor, solid output shaft) and MDSS (quill input adaptor, hollow output shaft) models. All other SE Encore (Integral and Modified) series reducers are filled to the optimum oil level indicated by the intended operational mounting position specified on the order. Consult the ILE-08 bulletin for lubricant level adjustments if a change in the mounting position is required. Following these recommendations ensures that all of the internal speed reducer components receive proper lubrication.

Oil Change Frequency

Advanced PAG based lubricants are relatively new in the marketplace. Therefore, few “hard and fast,” or “based-on-experience,” rules can apply to the frequency of oil changes. Any claims that a worm gear speed reducer lubricant “never needs to be changed” are fictitious. In reality, the current limited industry experience with PAG based lubricants combined with the wide range of application demands, operating environments, and differing user life expectations govern the need and frequency of lubricant changes.

The best approach to determining oil change frequency is for each “user” or “equipment builder” to base oil change frequency on lubricant sampling performed in conjunction with an experienced testing laboratory. Depending on the application, operating conditions, and service life demands, the sample testing might be suggested every year or ever five years. The results should be a guide for defining oil change frequencies.

Winsmith has not defined a required oil change frequency for the SE Encore series of worm gear speed reducers. In many indoor environments that are relatively contaminate free and under normally loaded application conditions, changing the lubricant may never be necessary within the desired life of the speed reducer. However, when operating in heavily loaded applications, high temperature, or contaminated environments, all lubricants will experience performance degradation over time. In these conditions, it is recommended to periodically change the lubricant to maximize the service life of the speed reducer components. Contact Winsmith for addition information on special lubrication requirements.

Glygoyle is a registered trademark of Exxon Mobil Corporation or one of its subsidiaries.



SE Encore Series Overhung Load and Thrust

OVERHUNG LOAD AND THRUST

Maximum Allowable Overhung Load

Overhung load (OHL) is a radial force imposed on the shaft of the reducer at a position beyond the outmost bearing. The values given in this catalog are the maximum allowable overhung load (or chain pull) capacity, in pounds, and are based upon the load being applied one shaft diameter from the oil seal face (max bore diameter for hollow shaft units). These values are independent of any other external forces (i.e. thrust) and are limited by the lesser of the bearing capacity or the shaft size. As speed increases above 2500 RPM, the bearing capacity decreases, reducing the overall OHL capacity. Additionally, the allowable overhung load will decrease as the center of the load gets farther from the speed reducer. This is discussed in detail under "Location of Overhung Loads." Contact Winsmith for OHL values of speed reducers with a bolt-on base (e.g. XDTS).

The bending moment capacity of the speed reducer, in pound-force inches (lbf-in), is determined by multiplying the OHL capacity by the distance from the bearing to the catalog OHL location l . See Table 2 for values of l .

Maximum Allowable Overhung Loads Based Upon Chain Pull

When a chain, gear, or belt drive is mounted to a reducer shaft, the OHL is estimated using the following equation:

$$\text{OHL} = \text{Transmitted Torque} / \text{Pitch Radius of the mounted member} \times \text{OHL Factor} \times \text{Service Factor}$$

This calculated value, in addition to the weight of the mounted member, must not exceed the allowable OHL capacity of the reducer. Overhung loads are subject to the same service factors that control the capacity of the reducer as well as the overhung load factors.

Overhung Load Factors

With a chain drive, the overhung load is equal to the torque divided by the radius of the sprocket because there is practically no pull on the loose side of the chain.

If an external gear or pinion is used, the overhung load is along the line of action and is greater than the load computed from the torque and pitch radius. In this case, AGMA recommends that the net overhung load derived from the torque and pitch radius of the gear be multiplied by an OHL factor of $1\frac{1}{4}$.

When a "V" belt sheave is specified, there is a pull on the loose side of the belt. In this case the sum of the pull on the tight side and on the loose side is the overhung load. AGMA recommends that the net overhung load derived from the torque be multiplied by an OHL factor of $1\frac{1}{2}$ to allow for this loose side tension.

A flat belt pulley requires a tension on the loose side to keep it tight. Therefore, AGMA recommends that the net overhung load derived from the torque be multiplied by an OHL factor of $2\frac{1}{2}$.

Variable speed drives, with a flat faced pulley on the reducer, and used with a "V" belt, derive their variability by changing the tension in the belt. In this case use an OHL factor of $2\frac{1}{2}$ to $3\frac{1}{2}$.

These factors are expressed in Table 1.

TABLE 1. OVERHUNG LOAD FACTORS

Type Of Load	Multiply The Actual Calculated OHL By:
Chain Sprocket	1
Gear or Pinion	1-1/4
"V" Belt	1-1/2
Flat Belt	2-1/2
Variable Speed Drive Pulley	3-1/2

Overhung Position and Direction Limitations

The overhung load capacities listed in this catalog may be used when the force from the chain pull is directed toward the base or applied parallel to the base on the near side of the sprocket as shown in Figure 1. These illustrations demonstrate the ideal chain pull conditions and should be used whenever possible.

When the force from the chain pull is directed away from the base or applied parallel to the base on the far side of the sprocket (as shown in Figure 2), it may be necessary to reduce the allowable overhung load capacity. Avoid these chain pull directions or contact Winsmith for assistance.

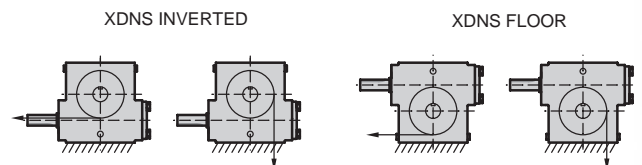

Figure 1.

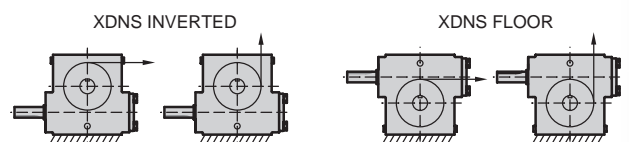

Figure 2.



SE Encore Series Overhung Load and Thrust

Location of Overhung Loads

In many cases, the center of the pulley, gear, or sprocket, which determines the location of the overhung load, does not coincide with the catalog position, "one shaft diameter from the seal face". If the location of the overhung load is outside this position, then the allowable overhung load (L_a) can be determined from the equation:

$$L_a = L_c \times \left(\frac{l}{l + \Delta l} \right)$$

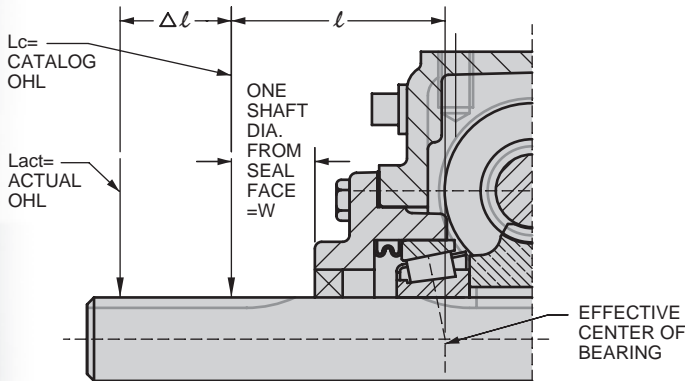

Where;

L_a = Allowable overhung load in pounds.

L_{act} = Actual overhung load.

L_c = Catalog rating of overhung load in pounds.

l = A factor given in Table 2 (This is the actual distance from the effective center of the bearing to the reference location for the catalog OHL capacity).

Δl = Distance from location of the actual overhung load to a point one shaft diameter from the seal face or housing.

Example:

An E30 XDNS reducer, with a gear ratio of 25:1, is subjected to a torque of 1500 lbf-in on the output shaft. The torque is transmitted through a chain sprocket of 3/4 pitch 23 teeth. The centerline of the sprocket is 5.00 inches from the center of the reducer. The service is 24 hours per day, uniform loading.

Data:

Service Factor = 1.25

Chain Overhung Load Factor = 1.0

Radius of 23 Tooth 3/4" Pitch Chain = $5.508"/2 = 2.754"$

Catalog Overhung Load = 1350 lbs

Catalog OHL Location from Center of Housing = $P - S + W = 5.88" - 2.88" + 1.375" = 4.375"$

(Where P, S and W are taken from the E30 XDNS reducer layout shown in another section of this catalog)

Actual OHL Location from Center of Housing = 5.00"

l (From Table 2) = 2.817"

$\Delta l = 5.00" - 4.375" = .625"$

Design Overhung Load = Torque/Radius x Service Factor x OHL Factor = $1500/2.754 \times 1.25 \times 1.00 = 680$ pounds

Allowable Overhung Load = $L_a = L_c \times l / (l + \Delta l) = 1350 \times 2.817 / (2.817 + .625) = 1105$ pounds

Since the allowable OHL (1105 lbf) exceeds the design OHL (680 lbf), the unit can support the load.

TABLE 2. VALUE OF "l" FOR SE ENCORE SPEED REDUCERS

Size	Solid Input Shaft			Output Shaft					
	SGL Reduction	DBL Reduction Worm-Worm	DBL Reduction Worm-Helical	Solid Output & Top Ext Vert. Output	Solid Output Bottom Ext Vert. Output	Hollow Output Except Drywell	Drop Bearing	Drywell Cover Side	Drywell Flange Side
E13	1.451			1.905	1.905				
E17	1.580	1.451		2.205	2.205	2.388			
E20	1.580	1.451		2.205	2.205	2.906			
E24	2.030	1.580	1.760	2.440	2.478	3.140			
E26	2.380	1.580	1.760	2.440	2.478	3.461	2.544		
E30	2.080	1.580	1.760	2.817	2.793	3.712	2.992	4.158	3.716
E35	2.980	1.580	1.760	3.303	3.303	4.103	3.312	4.715	3.914
E43	2.875	2.380	2.040	3.743	3.743	5.230	3.555	5.841	4.963

Maximum Allowable Thrust Load

The maximum allowable thrust load values (lbf) in this catalog assume that no simultaneous overhung load exists. Contact Winsmith if OHL and thrust loads exist simultaneously in the application.

SE Encore Series Thermal Limit Ratings

THERMAL LIMIT RATINGS ³																								
Maximum input HP at 68°F (20°C) ambient temperature Single reduction with Mobil Glygoyle 460 lubricant																								
SIZE	RATIO ¹		5		7.5		10		15		20		25		30		40		50		60		80	
	INPUT RPM ²	OUTPUT RPM	INPUT HP	OUTPUT TORQUE (lbf-in.)	INPUT HP	OUTPUT TORQUE (lbf-in.)	INPUT HP	OUTPUT TORQUE (lbf-in.)	INPUT HP	OUTPUT TORQUE (lbf-in.)	INPUT HP	OUTPUT TORQUE (lbf-in.)	INPUT HP	OUTPUT TORQUE (lbf-in.)	INPUT HP	OUTPUT TORQUE (lbf-in.)	INPUT HP	OUTPUT TORQUE (lbf-in.)	INPUT HP	OUTPUT TORQUE (lbf-in.)	INPUT HP	OUTPUT TORQUE (lbf-in.)	INPUT HP	OUTPUT TORQUE (lbf-in.)
E13	Not Thermally Limited																							
E17																								
E20																								
E24																								
E26	2500	500	6.71	807	5.89	1055	5.08	1204	3.71	1286	2.94	1325	2.50	1382	2.13	1376	1.71	1416	1.43	1415	-	-	-	-
E30	2500	500	9.38	1134	8.34	1505	7.18	1715	5.33	1872	4.49	2070	3.70	2090	3.14	2084	2.52	2159	2.04	2097	-	-	-	-
	1750	350	10.49	1821	-	-	-	-	-	-	-	-	-	-	-	-	-	-	-	-	-	-	-	-
E35	2500	500	12.86	1562	10.90	1973	9.03	2157	6.58	2309	5.52	2545	4.75	2699	3.88	2575	3.20	2753	2.69	2804	2.32	2804	-	-
	1750	350	12.09	2093	11.62	3012	9.50	3254	-	-	-	-	-	-	-	-	-	-	-	-	-	-	-	-
E43	2500	500	19.27	2356	14.72	2673	11.89	3717	8.57	3021	7.06	3268	5.51	3106	4.81	3200	3.99	3438	3.43	3592	3.02	3686	2.42	3707
	1750	350	17.71	3086	13.50	3491	10.90	4873	7.87	3939	6.50	4267	5.09	4065	4.46	4197	3.73	4532	3.23	4764	2.86	4926	-	-
	1160	232	15.51	4056	11.80	4574	9.55	5848	6.93	5173	5.76	5631	4.59	5443	4.20	5900	3.74	6864	-	-	-	-	-	-
	870	174	13.96	4846	10.68	5486	8.65	7355	6.30	6218	5.26	6787	4.43	6980	4.08	7607	-	-	-	-	-	-	-	-
	600	120	12.13	6069	9.32	6886	7.58	11409	5.56	7847	4.68	8612	4.04	9077	3.74	9944	-	-	-	-	-	-	-	-
	300	60	9.49	9360	-	-	-	-	-	-	-	-	-	-	-	-	-	-	-	-	-	-	-	-

1. Exact ratio
 2. If input speed is below 1160 RPM, please specify speed and mounting position to ensure proper lubrication.
 3. If the input HP thermal capacity or limit exceeds the 1.00 service factor mechanical rating, then the reducer is not thermally limited and no thermal rating is shown in the above table.

Speed Reducer Backlash

Speed Reducer Backlash

Backlash is the amount of clearance between the meshing teeth of two mating gears (Figure 1). An individual gear does not have backlash. In any gear set some amount of clearance is necessary for the gear set to perform properly.

Backlash provides clearance for lubricant to enter the gear mesh. It also compensates for tolerance variations including gear geometry (tooth thickness, run out, lead angle, tooth profile), assembled center distance, bearing run out, and thermal expansion. Insufficient backlash may cause noise, overloading, overheating of gears and bearings, possible seizing, and failure.

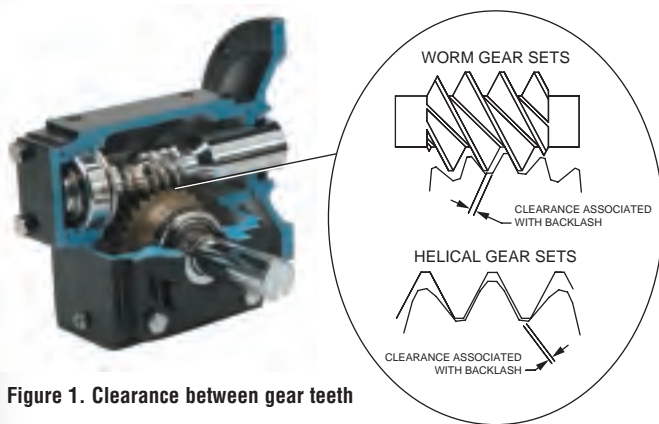

Figure 1. Clearance between gear teeth

Backlash in a worm gear set can change during the operating life of the gear reducer. Any wear that occurs will increase the space between the mating components, resulting in an increase in backlash. The majority of wear occurs during run-in when the gear develops an operating surface consistent with the driven load (Figure 2).

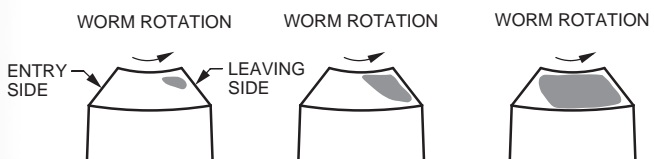

Figure 2. Bronze Gear Run-In

When is backlash an application consideration?

When worm gear reducers operate continuously in a single direction and in the absence of load reversals, backlash is generally not an application consideration. In this case, the standard reducer backlash is suitable.

For applications involving frequent starting and stopping, reverse rotation while positioning, or that have load reversals (when the torque changes direction causing separation and re-engagement of the tooth flanks), a worm reducer with reduced backlash is recommended (See Winsmith S-Minimizer products that are shipped with a maximum of 11 arc minutes). For precise positioning applications requiring near zero backlash, an adjustable precision-manufactured reducer is recommended (See Winsmith S-Eliminator products that are shipped with a maximum of 2 arc minutes).

Backlash Measurement

Backlash is typically measured by restricting the rotation of one of the gears in a set and measuring the rotational (arc) movement of the mating gear.

When measuring the backlash in worm gear reducers, the arc movement of the output shaft and attached gear is measured while restricting the rotation of the worm shaft. It is not correct to measure the worm arc movement while restricting the gear rotation because

Measuring Backlash

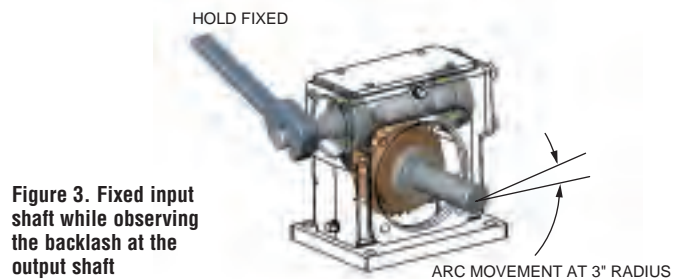

Figure 3. Fixed input shaft while observing the backlash at the output shaft

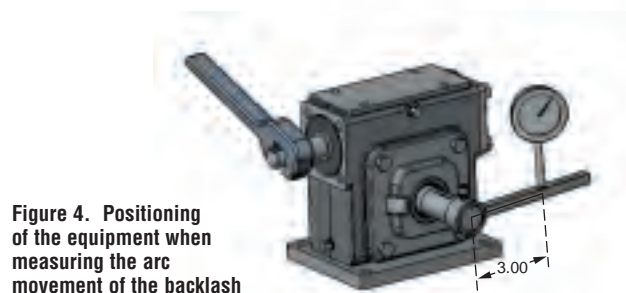

Figure 4. Positioning of the equipment when measuring the arc movement of the backlash

the measured result will be much greater and is not an indication of true tooth clearance. Axial clearance in the worm bearing(s) will add to the arc movement of the gear and appears as backlash. Typically, axial clearance is minimal and of little consequence for most applications. However, when low backlash is an application consideration, bearing endplay must be considered and reduced if necessary.

Speed Reducer Backlash

Backlash specifications are generally provided in one of two terms: inches of movement at a defined radius or arc movement (degrees, minutes, seconds). The difference between these two terms is the unit of measure. While both of these terms accurately describe backlash measurement, the choice of term is usually associated with a specific purpose.

Backlash in inches of movement at a defined radius is generally associated with the actual backlash measurement. It refers to the arc movement about the center of the subject shaft at some reference radius. There is a quasi-industry standard of three inches for the reference radius. Because the arc movement will vary with the reference radius it is more convenient to convert this measurement to degrees because it is independent of the reference radius. When the level of precision is high, the backlash is often stated in arc minutes. Formulas for converting backlash measurements are:

1. Backlash in degrees as measured from some reference radius:

$$\text{Backlash in degrees} = \frac{\text{Backlash in inches} \times 57.296}{\text{Reference Radius (inches)}}$$

2. Backlash in inches at a defined reference radius:

$$\text{Backlash in inches} = \frac{\text{Backlash in degrees} \times \text{Radius (inches)}}{57.296}$$

3. Backlash in arc minutes:

$$\text{Backlash in arc minutes} = \text{Backlash in degrees} \times 60$$

The integer value is the measurement of arc minutes. Arc seconds are obtained by multiplying the decimal remainder by 60.

EXAMPLE:

$$\begin{aligned} .18 \text{ degrees} \times 60 &= 10.8 \text{ arc minutes} \\ .8 \text{ remainder} \times 60 &= 48 \text{ arc seconds} \end{aligned}$$

Therefore, 18 degrees = 10 arc minutes and 48 arc seconds

BACKLASH LEVEL FOR WINSMITH® PRODUCTS

IN ARC MINUTES	IN DEGREES*	IN INCHES@ REFERENCE RADIUS			BACKLASH LEVEL FOR WINSMITH PRODUCTS
		3"	12"	48"	
1	.017°	.0006"	.0035"	.0140"	S-ELIMINATOR™
2	.033°	.0017"	.0070"	.0279"	
3	.050°	.0026"	.0105"	.0419"	
4	.067°	.0035"	.0140"	.0558"	C-ELIMINATOR
5	.083°	.0044"	.0176"	.0704"	
6	.100°	.0052"	.0209"	.0837"	
7	.117°	.0061"	.0244"	.0977"	C-MINIMIZER
8	.133°	.0070"	.0279"	.1117"	
9	.150°	.0079"	.0314"	.1256"	
10	.167°	.0087"	.0349"	.1396"	S-MINIMIZER
11	.183°	.0096"	.0384"	.1535"	
12	.200°	.0105"	.0419"	.1675"	
13	.217°	.0113"	.0454"	.1814"	SE Encore
14	.233°	.0122"	.0488"	.1954"	
15	.250°	.0131"	.0523"	.2094"	
16	.267°	.0140"	.0558"	.2233"	
17	.283°	.0148"	.0593"	.2373"	
18	.300°	.0157"	.0628"	.2512"	
19	.317°	.0166"	.0663"	.2652"	
20	.333°	.0174"	.0698"	.2791"	
21	.350°	.0183"	.0733"	.2931"	
22	.367°	.0192"	.0768"	.3070"	
23	.383°	.0200"	.0803"	.3210"	
24	.400°	.0209"	.0837"	.3350"	
25	.417°	.0218"	.0872"	.3489"	
26	.433°	.0227"	.0907"	.3629"	
27	.450°	.0236"	.0942"	.3768"	
28	.467°	.0244"	.0977"	.3908"	
29	.483°	.0253"	.1012"	.4047"	
30	.500°	.0262"	.1047"	.4187"	

*To convert to radians, divide degrees by 57.3°.



2D DRAWINGS & 3D MODELS
www.WINSMITH.com



Speed Reducer Efficiency and Run-in

Speed Reducer Efficiency

The efficiency of an SE Encore series worm gear speed reducer depends on many factors such as the lead angle of the worm threads, input speed to the reducer, operating load, and the temperature of the Mobil Glygoyle 460 lubricant.

The efficiencies published in this catalog are in accordance with ISO/DIS 14521.2 and are based on rated output torque, an operating temperature reflecting continuous operation, and Mobil Glygoyle 460 synthetic lubricant. If the operating temperature is not reached (such as with intermittent service), the operating efficiency will be less than rated efficiency. Speed reducer efficiency is optimized by performing a proper run-in during the initial use of a worm gear speed reducer.

When the rated efficiency is not listed in the catalog, it may be easily calculated in the following manner:

$$\text{Efficiency} = \text{Output Horsepower} / \text{Input Horsepower}$$

In order to establish the efficiencies of reducers where only the output torque and input horsepower are given, the output torque is converted to output horsepower by the following formula:

$$\text{Output Horsepower} = [\text{Output Torque (lbf-in)} \times \text{Output RPM}] / 63,025$$

Speed Reducer Run-In

“Run-in,” sometimes referred to as “break-in,” is an important process required to optimize worm gear speed reducer service life. In many applications, concern or care relative to worm gear speed reducer run-in is not necessary. However, in some applications, properly addressing the interaction of the composite speed reducer materials may be critical to achieving desired service life expectations.

There are two significant elements of run-in. The first element is the run-in of the radial shaft lip seals and the respective mating shafts. Seal service life is dependent on many application and environmental factors; it can vary from 12 months to more than 10 years. However, the radial shaft lip seals in a speed reducer will reach their designed level of performance after an initial break-in period. It is normal and should be expected that the seal may permit some weepage of lubricant along the rotating shaft during the break-in period. After several hours of run-in, the seal and shaft will develop a conformal running surface with each other that will provide leak free operation throughout the components expected service life.

The second element is the run-in of the bronze gear and the case hardened worm input shaft. Worm gears operate using some degree of sliding action between

the bronze gear and steel worm-on-shaft. Therefore, achieving the rated efficiency requires run-in time to obtain a work hardened surface on the bronze. Experience indicates that completing a run-in procedure lowers the initial friction in the gearset by 10 to 15 percent regardless of the bronze gear surface finish quality.

The gearing has a better chance of providing maximum performance and service life if part of the full working load is initially applied for a pre-set period of time. The first few hours of operation at gradually increasing loads will reduce the gearset friction. Gradually increasing to the full working load over 10 to 100 hours of operation will minimize the occurrence of any surface damage. Depending on the operating load and on the size and speed of the gearing, the efficiency will stabilize to a steady value during this period of run-in and the operating temperature will decrease (see Figure 1).

A reasonable run-in procedure consists of applying half the required load for a few hours and then increasing it to the full operating load in at least two stages. Applying the full load immediately concentrates high contact pressures on small areas. This may cause high local surface temperatures and some temporary damage to the surfaces. However, temporary damage to the bronze gear surfaces will often “heal” after continued running at full or less than full load.

In many applications, concern or care relative to worm gear speed reducer run-in is not necessary. However, in some applications, properly addressing the interaction of the composite speed reducer materials may be critical to achieving desired service life expectations.

Typical Worm Gear Run-in

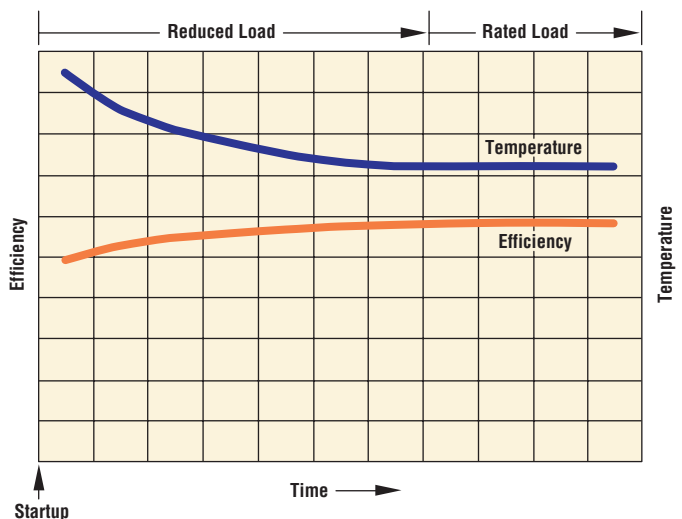

Figure 1. Operating temperature drop as a result of the increase in efficiency from a proper run-in procedure

Service Factor Section

Application service factors are used to adjust the SE Encore selection process to compensate for various loads that may be applied to the worm gear reducer during normal operation. Service factors are applied only to the mechanical rating and not the thermal rating of a worm gear reducer. The charts in this section have been expanded to include typical power transmission applications and their normal load rating. These charts are per AGMA standards. The ratings section of this catalog includes gear reducer rating tables for UNIFORM (1.00) load and service factored rating tables for MODERATE (1.25) and HEAVY (1.50) shock load applications.

Important Terms

APPLIED HP or TORQUE – This is the actual power applied to the input of the worm gear reducer by a drive or motor.

SERVICE FACTOR – Represents the adjustment needed in the APPLIED HP or TORQUE to insure the original design life of the SE Encore speed reducer is maintained in the application.

DESIGN HP or TORQUE – Include the appropriate service factor that accounts for the conditions under which the reducer will be used. Example: 1 HP APPLIED motor input times 1.25 SERVICE FACTOR results in a 1.25 DESIGN HP.

Load classifications are momentary changes in the applied load without changing direction or starting and stopping:

UNIFORM LOAD – Recurring shock loads that do not exceed the specified input or prime mover power.

MODERATE SHOCK LOAD – Recurring shock loads that do not exceed 125% of the specified input or prime mover power.

HEAVY SHOCK LOAD – Recurring shock loads that do not exceed 150% of the specified input or prime mover power.

EXTREME SHOCK LOAD – Recurring shock loads that do not exceed 175% of the specified input or prime mover power.

APPLICATION	SERVICE FACTORS		
	UP TO 3 HRS. DAY	3-10 HRS. DAY	OVER 10 HRS. DAY
AGITATORS (Mixers)			
Pure Liquids	–	1.00	1.25
Liquids and Solids	1.00	1.25	1.50
Liquids–Variable Density	1.00	1.25	1.50
BLOWERS			
Centrifugal	1.00	1.00	–
Lobe	1.00	1.25	1.50
Vane	–	1.00	1.25
BREWING AND DISTILLING			
Bottling Machinery	–	1.00	1.25
Brew Kettles, Continuous Duty	–	1.00	1.25
Cookers–Continuous Duty	–	1.00	1.25
Mash Tubs–Continuous Duty	–	1.00	1.25
Scale Hopper, Frequent Starts	1.00	1.25	1.50
CAN FILLING MACHINES	–	1.00	1.25
CAR DUMPERS	1.25	1.50	1.75
CAR PULLERS	1.00	1.25	1.50
CLARIFIERS	–	1.00	1.25
CLASSIFIERS	1.00	1.25	1.50
CLAY WORKING MACHINERY			
Brick Press	1.25	1.50	1.75
Briquette Machine	1.25	1.50	1.75
Pug Mill	1.00	1.25	1.50
COMPACTORS	1.50	1.75	2.00
COMPRESSORS			
Centrifugal	–	1.00	1.25
Lobe	1.00	1.25	1.50
Reciprocating, Multi-Cylinder	1.00	1.25	1.50
Reciprocating, Single-Cylinder	1.25	1.50	1.75

APPLICATION	SERVICE FACTORS		
	UP TO 3 HRS. DAY	3-10 HRS. DAY	OVER 10 HRS. DAY
CONVEYORS–GENERAL PURPOSE			
Uniformly loaded or fed	–	1.00	1.25
Not uniformly fed	1.00	1.25	1.50
Reciprocating or shaker	1.25	1.50	1.75
CRANES			
Dry Dock			
Main Hoist	1.25	1.50	1.75
Auxiliary Hoist	1.25	1.50	1.75
Boom Hoist	1.25	1.50	1.75
Slewing Drive	1.25	1.50	1.75
Traction Drive	1.50	1.50	1.50
Container			
Main Hoist			
Boom Hoist			
Trolley Drive			
(Gantry or Traction Drive)			
Mill Duty			
Main Hoist			
Auxiliary			
Bridge and Trolley Travel			
Industrial Duty			
Main	1.00	1.25	1.50
Auxiliary			
Bridge and Trolley Travel			
CRUSHER			
Stone or Ore	1.50	1.75	2.00
DREDGES			
Cable Reels	1.00	1.25	1.50
Conveyors	1.00	1.25	1.50

Service Factor Section



APPLICATION	SERVICE FACTORS		
	UP TO 3 HRS. DAY	3-10 HRS. DAY	OVER 10 HRS. DAY
DREDGES (Continued)			
Cutter Head Drives	1.25	1.50	1.75
Pumps	1.00	1.25	1.50
Screen Drives	1.25	1.50	1.75
Stackers	1.00	1.25	1.50
Winches	1.00	1.25	1.50
ELEVATORS			
Bucket	1.00	1.25	1.50
Centrifugal Discharge	–	1.00	1.25
Escalators	Contact Winsmith		
Freight	Contact Winsmith		
Gravity Discharge	–	1.00	1.25
EXTRUDERS			
General	1.25	1.25	1.25
Plastics			
Variable Speed Drive	1.50	1.50	1.50
Fixed Speed Drive	1.75	1.75	1.75
Rubber			
Continuous Screw Operations	1.50	1.50	1.50
Intermittent Screw Operations	1.75	1.75	1.75
FANS			
Centrifugal	–	1.00	1.25
Cooling Towers	Contact Winsmith		
Forced Draft	1.25	1.25	1.25
Induced Draft	1.00	1.25	1.50
Industrial & Mine	1.00	1.25	1.50
FEEDERS			
Apron	–	1.25	1.50
Belt	1.00	1.25	1.50
Disc	–	1.00	1.25
Reciprocating	1.25	1.50	1.75
Screw	1.00	1.25	1.50
FOOD INDUSTRY			
Cereal Cooker	–	1.00	1.25
Dough Mixer	1.00	1.25	1.50
Meat Grinders	1.00	1.25	1.50
Slicers	1.00	1.25	1.50
GENERATORS AND EXCITERS			
HAMMER MILLS			
HOISTS			
Heavy Duty	1.25	1.50	1.75
Medium Duty	1.00	1.25	1.50
Skip Hoist	1.00	1.25	1.50
LAUNDRY TUMBLERS			
LAUNDRY WASHERS			
LUMBER INDUSTRY			
Barkers			
Spindle Feet	1.25	1.25	1.50
Main Drive	1.50	1.50	1.50
Conveyors			
Burner	1.25	1.25	1.50
Main or Heavy Duty	1.50	1.50	1.50
Main Log	1.50	1.50	1.75
Re-Saw, Merry-Go-Round	1.25	1.25	1.50
Slab	1.50	1.50	1.75
Transfer	1.25	1.25	1.50
Chains			
Floor	1.50	1.50	1.50
Green	1.50	1.50	1.50

APPLICATION	SERVICE FACTORS		
	UP TO 3 HRS. DAY	3-10 HRS. DAY	OVER 10 HRS. DAY
LUMBER INDUSTRY (Continued)			
Cut-off Saws			
Chain	1.50	1.50	1.50
Drag	1.50	1.50	1.75
Debarking Drums	1.50	1.50	1.75
Feeds			
Edger	1.25	1.25	1.50
Gang	1.50	1.50	1.50
Trimmer	1.25	1.25	1.50
Log Deck	1.50	1.50	1.50
Log Hauls–Incline–Well Type	1.50	1.50	1.50
Log Turning Devices	1.50	1.50	1.50
Planer Feed	1.25	1.25	1.25
Planer Tilting Hoists	1.50	1.50	1.50
Rolls–Live-off brg.–Roll Cases	1.50	1.50	1.50
Sorting Table	1.25	1.25	1.50
Tipple Hoist	1.25	1.25	1.50
Transfers			
Chain	1.50	1.50	1.50
Craneway	1.50	1.50	1.50
Tray Drives	1.25	1.25	1.50
Veneer Lathe Drives	Contact Winsmith		
METAL MILLS			
Draw Bench Carriage and Main Drive	1.00	1.25	1.50
Runout Tables, Non-reversing			
Group Drives	1.00	1.25	1.50
Individual Drives	1.50	1.50	1.75
Reversing	1.50	1.50	1.75
Slab Pushers	1.25	1.25	1.50
Shears	1.50	1.50	1.75
Wire Drawing	1.00	1.25	1.50
Wire Winding Machine	1.00	1.25	1.50
METAL STRIP PROCESSING MACHINERY			
Bridles	1.25	1.25	1.50
Coilers & Uncoilers	1.00	1.00	1.25
Edge Trimmers	1.00	1.25	1.50
Flatteners	1.00	1.25	1.50
Loopers (Accumulators)	1.00	1.00	1.00
Pinch Rolls	1.00	1.25	1.50
Scrap Choppers	1.00	1.25	1.50
Shears	1.50	1.50	1.75
Slitters	1.00	1.25	1.50
MILLS, ROTARY TYPE			
Ball & Rod			
Spur Ring Gear	1.50	1.50	1.75
Helical Ring Gear	1.50	1.50	1.50
Direct Connected	1.50	1.50	1.75
Cement Kilns	1.50	1.50	1.50
Dryers & Coolers	1.50	1.50	1.50
MIXERS, CONCRETE	1.00	1.25	1.50
PAPER MILLS			
Agitator (Mixer)	1.50	1.50	1.50
Agitator for Pure Liquors	1.25	1.25	1.25
Barking Drums	1.75	1.75	1.75
Barkers–Mechanical	1.75	1.75	1.75
Beater	1.50	1.50	1.50
Breaker Stack	1.25	1.25	1.25
Calender (anti-friction bearings only)	1.25	1.25	1.25
Chipper	1.75	1.75	1.75

Appendix



Service Factor Section

APPLICATION	SERVICE FACTORS		
	UP TO 3 HRS. DAY	3-10 HRS. DAY	OVER 10 HRS. DAY
PAPER MILLS (Continued)			
Chip Feeder	1.50	1.50	1.50
Coating Rolls	1.25	1.25	1.25
Conveyors			
Chip, Bark, Chemical	1.25	1.25	1.25
Log (including Slab)	1.75	1.75	1.75
Couch Rolls	1.25	1.25	1.25
Cutter	1.75	1.75	1.75
Cylinder Molds	1.25	1.25	1.25
Dryers (anti-friction bearings only)			
Paper Machine	1.25	1.25	1.25
Conveyor Type	1.25	1.25	1.25
Embosses	1.25	1.25	1.25
Extruder	1.50	1.50	1.50
Fourdriner Rolls (Includes Lumpbreaker, dandy roll, wire turning, and return rolls)	1.25	1.25	1.25
Jordan	1.25	1.25	1.25
Kiln Drive	1.50	1.50	1.50
Mt. Hope Rolls	1.25	1.25	1.25
Paper Rolls	1.25	1.25	1.25
Platter	1.50	1.50	1.50
Presses—Felt & Suction	1.25	1.25	1.25
Pulper	1.50	1.50	1.75
Pumps—Vacuum	1.50	1.50	1.50
Reel (Surface Type)	1.25	1.25	1.50
Screens			
Chip	1.50	1.50	1.50
Rotary	1.50	1.50	1.50
Vibrating	1.75	1.75	1.75
Size Press	1.25	1.25	1.25
Thickener (AC Motor)	1.50	1.50	1.50
(DC Motor)	1.25	1.25	1.25
Washer (AC Motor)	1.50	1.50	1.50
(DC Motor)	1.25	1.25	1.25
Wind & Unwind Stand	1.00	1.00	1.00
Winders (Surface Type)	1.25	1.25	1.25
Yankee Dryers (anti-friction bearings only)	1.25	1.25	1.25
PLASTICS INDUSTRY—PRIMARY PROCESSING			
Intensive Internal Mixers			
Batch Mixers	1.75	1.75	1.75
Continuous Mixers	1.50	1.50	1.50
Batch Drop Mill—2 smooth rolls	1.25	1.25	1.25
Continuous Feed, Holding & Blend Mill	1.25	1.25	1.25
Compounding Mills	1.25	1.25	1.25
Calenders	1.50	1.50	1.50
PLASTICS INDUSTRY—SECONDARY PROCESSING			
Blow Molders	1.50	1.50	1.50
Coating	1.25	1.25	1.25
Film 1.25	1.25	1.25	-
Pipe	1.25	1.25	1.25
Pre-plasticizers	1.50	1.50	1.50
Rods	1.25	1.25	1.25
Sheet	1.25	1.25	1.25
Tubing	1.25	1.25	1.50
PULLERS—BARGE HAUL	1.00	1.50	1.75
PUMPS			
Centrifugal	-	1.00	1.25
Proportioning	1.00	1.25	1.50

APPLICATION	SERVICE FACTORS		
	UP TO 3 HRS. DAY	3-10 HRS. DAY	OVER 10 HRS. DAY
PUMPS (Continued)			
Reciprocating			
Single Acting, 3 or more cylinders	1.00	1.25	1.50
Double Acting, 2 or more cylinders	1.00	1.25	1.50
Rotary			
Gear Type	-	1.00	1.25
Lobe	-	1.00	1.25
Vane	-	1.00	1.25
RUBBER INDUSTRY			
Intensive Internal Mixers			
Batch Mixers	1.50	1.75	1.75
Continuous Mixers	1.25	1.50	1.50
Mixing Mill—2 smooth rolls—(If corrugated rolls are used, then use the same service factors that are used for a Cracker Warmer.)	1.50	1.50	1.50
Batch Drop Mill—2 smooth rolls	1.50	1.50	1.50
Cracker Warmer—2 roll; 1 corrugated roll	1.75	1.75	1.75
Cracker Warmer—2 corrugated rolls	1.75	1.75	1.75
Holding, Feed & Blend Mill—2 rolls	1.25	1.25	1.25
Refiner—2 rolls	1.50	1.50	1.50
Calenders	1.50	1.50	1.50
SAND MILLER			
SEWAGE DISPOSAL EQUIPMENT			
Bar Screens	-	1.00	1.25
Chemical Feeders	-	1.00	1.25
Dewatering Screens	1.00	1.25	1.50
Scum Breakers	1.00	1.25	1.50
Slow or Rapid Mixers	1.00	1.25	1.50
Sludge Collectors	1.00	1.00	1.25
Thickeners	1.00	1.25	1.50
Vacuum Filters	1.00	1.25	1.50
SCREENS			
Air Washing	-	1.00	1.25
Rotary—Stone or Gravel	1.00	1.25	1.50
Traveling Water Intake	-	1.00	1.25
SUGAR INDUSTRY			
Beet Slicer	1.50	1.50	1.75
Cane Knives	1.50	1.50	1.50
Crushers	1.50	1.50	1.50
Mills low speed end	1.50	1.50	1.50
TEXTILE INDUSTRY			
Batchers	1.00	1.25	1.50
Calenders	1.00	1.25	1.50
Cards	1.00	1.25	1.50
Dry Cans	1.00	1.25	1.50
Dryers	1.00	1.25	1.50
Dyeing Machinery	1.00	1.25	1.50
Looms	1.00	1.25	1.50
Mangles	1.00	1.25	1.50
Nappers	1.00	1.25	1.50
Pads	1.00	1.25	1.50
Slashers	1.00	1.25	1.50
Soapers	1.00	1.25	1.50
Spinners	1.00	1.25	1.50
Tenter Frames	1.00	1.25	1.50
Washers	1.00	1.25	1.50
Winders	1.00	1.25	1.50



Service Factor Section

Momentary Overloads And Frequent Starts And Stops

Normal starting , or occasional momentary peak loads up to 300% of catalog rating at 1750 RPM (maximum of 2 seconds each occurrence) and that occur two or three times per day are permissible when using a service factor of 1.0. If either of these values is exceeded, a service factor of 1.5 should be used. Heavy starting loads may be encountered when the output shaft of the reducer is directly coupled to larger gears or heavy masses. In these cases, a service factor of 2.0 should be used. Reversing drives and those subjected to quickly repeated shock loads of unusual or unpredictable intensity and stalling loads, drives that are overrunning, or that “wind up” due to quick power stoppage and storage of energy are not covered by the service factors above. In these cases, a service factor of at least 3.0 is

recommended. Applications with frequent starts and stops should be evaluated using Winsmith’s Full Duty Cycle selection method that is detailed in the Motion Control Products catalog, available at www.WINSMITH.com.

CONVERSION TABLE

To Find Equivalent Service Factor When Using Single or Multi-Cylinder Engines.

For Hydraulic or Electric Motor Service Factor of:	Use this Service Factor for Single Cylinder Engines	Use this Service Factor for Multi-Cylinder Engines
1.00	1.50	1.25
1.25	1.75	1.50
1.50	2.00	1.75
1.75	2.25	2.00
2.00	2.50	2.25

AGMA SERVICE FACTOR CHART BASED ON LOAD CLASSIFICATION

Prime Mover	Duration of Service Per Day	Uniform	Driven Machine Load Classifications		
			Moderate Shock	Heavy Shock	Extreme Shock
Electric and Hydraulic Motors	Occasional 1/2 hour	1.00	1.00	1.00	1.25
(See above chart for internal combustion engines)	Less than 3 hours	1.00	1.00	1.25	1.50
	3-10 hours	1.00	1.25	1.50	1.75
	Over 10 hours	1.25	1.50	1.75	2.00

FOLLOWING SERVICE FACTORS APPLY FOR APPLICATIONS INVOLVING FREQUENT STARTS AND STOPS

Prime Mover	Duration of Service Per Day	Uniform	Driven Machine Load Classifications		
			Moderate Shock	Heavy Shock	Extreme Shock
Electric and Hydraulic Motors	Occasional 1/2 hour	1.00	1.00	1.25	1.50
(See above chart for internal combustion engines)	Less than 3 hours	1.00	1.25	1.50	1.75
	3-10 hours	1.25	1.50	1.75	2.00
	Over 10 hours	1.50	1.75	2.00	2.25

Resource Guide and Conversion Tables

LENGTH AND DISTANCE

From/To	in	ft	mm	cm	m
in	1	0.0833	25.4	2.54	0.0254
ft	12	1	304.8	30.48	0.3048
mm	0.03937	0.00328	1	0.1	0.001
cm	0.3937	0.03281	10	1	0.01
m	39.37	3.281	1000	100	1

FORCE

From/To	lb(f)	N	ozf	kgf	gmf
lbf	1	4.4482	16	.45359	453.6
N	.22481	1	3.5967	.10197	-
ozf	.0625	.27801	1	.02835	28.35
kgf	2.205	9.80665	35.274	1	1000
gmf	2.205x10 ⁻³	-	.03527	.001	1

Note: lbf = 1 slug x 1 ft/s² N = 1 kg x 1 m/s²

TEMPERATURE

$$F = (1.8 \times C) + 32$$

$$C = .555 (F - 32)$$

GRAVITY

(Acceleration Constant)

$$G = \frac{386.1 \text{ in}}{\text{s}^2} = \frac{32.17 \text{ ft}}{\text{s}^2} = \frac{9.806 \text{ m}}{\text{s}^2}$$

TORQUE

From/To	gmf-cm	ozf-in	kgf-cm	lbf-in	N-m	ibf-ft	kgf-m
gmf-cm	1	1.388 x 10 ⁻²	10 ⁻³	8.679 x 10 ⁻⁴	9.806 x 10 ⁻⁵	7.233 x 10 ⁻⁵	10 ⁻⁵
ozf-in	72.007	1	7.200 x 10 ⁻²	6.25 x 10 ⁻²	7.061 x 10 ⁻³	5.208 x 10 ⁻³	7.200 x 10 ⁻⁴
kgf-cm	1000	13.877	1	.8679	9.806 x 10 ⁻²	7.233 x 10 ⁻²	10 ⁻²
lbf-in	1.152 x 10 ³	16	1.152	1	.113	8.333 x 10 ⁻²	1.152 x 10 ⁻²
N-m	1.019 x 10 ⁴	141.612	10.197	8.850	1	.737	.102
ibf-ft	1.382 x 10 ⁴	182	13.825	12	1.356	1	.138
kgf-m	10 ⁵	1.388 x 10 ³	100	86.796	9.806	7.233	1

INERTIA (ROTARY)

From/To	gmf-cm ²	oz-in ²	gmf-cm-s ²	kg-cm ²	lb-in ²	oz-in-s ²	lb-ft ²	kg-cm-s ²	lb-in-s ²	lb-ft-s ² or slug-ft-s ²
gm-cm ²	1	5.46 x 10 ⁻³	1.02 x 10 ⁻³	10 ⁻³	3.417 x 10 ⁻⁴	1.41 x 10 ⁻⁵	2.37 x 10 ⁻⁶	1.02 x 10 ⁻⁶	8.85 x 10 ⁻⁷	7.38 x 10 ⁻⁸
oz-in ²	182.9	1	.187	.183	.0625	2.59 x 10 ⁻³	4.34 x 10 ⁻⁴	1.86 x 10 ⁻⁴	1.61 x 10 ⁻⁴	1.35 x 10 ⁻⁵
gm-cm-s ²	980.6	5.361	1	.981	.335	1.39 x 10 ⁻²	2.33 x 10 ⁻³	10 ⁻³	8.68 x 10 ⁻⁴	7.23 x 10 ⁻⁵
kg-cm ²	1000	5.467	1.019	1	.342	1.42 x 10 ⁻²	2.37 x 10 ⁻³	1.02 x 10 ⁻³	8.85 x 10 ⁻⁴	7.38 x 10 ⁻⁵
lb-in ²	2.92 x 10 ³	16	2.984	2.925	1	4.14 x 10 ⁻²	6.94 x 10 ⁻³	2.98 x 10 ⁻³	2.59 x 10 ⁻³	2.15 x 10 ⁻⁴
oz-in-s ²	7.06 x 10 ⁴	386.1	72.0	70.62	24.13	1	.168	7.20 x 10 ⁻²	6.25 x 10 ⁻²	5.21 x 10 ⁻³
lb-ft ²	4.21 x 10 ⁵	2304	429.4	421.3	144	5.963	1	.430	.373	3.10 x 10 ⁻²
kg-cm-s ²	9.81 x 10 ⁵	5.36 x 10 ³	1000	980.6	335.1	13.887	2.327	1	.868	7.23 x 10 ⁻²
lb-in-s ²	1.129 x 10 ⁶	6.18 x 10 ³	1.152 x 10 ³	1.13 x 10 ³	386.1	16	2.681	1.152	1	8.33 x 10 ⁻²
lb-ft-s ² or slug-ft ²	1.355 x 10 ⁷	7.42 x 10 ⁴	1.38 x 10 ⁴	1.35 x 10 ⁴	4.64 x 10 ³	192	32.17	13.823	12	1

MASS

From/To	gm	kg	slug	lb(m)	oz(m)
gm	1	.001	6.852 x 10 ⁻⁵	2.205 x 10 ⁻³	.03527
kg	1000	1	6.852 x 10 ⁻²	2.205	35.274
slug	14590	14.59	1	32.2	514.72
lb(m)	453.6	.45359	.0311	1	16
oz(m)	28.35	.02835	1.94 x 10 ⁻³	0.0625	1

MATERIAL DENSITIES

From/To	oz/in ³	in/lb ³	gm/cm ³
Aluminum	1.570	0.098	2.720
Brass	4.960	0.310	8.600
Bronze	4.720	0.295	8.170
Copper	5.150	0.322	8.910
Plastic	0.640	0.040	1.110
Steel	4.480	0.280	7.750
Hard Wood	0.460	0.029	0.800
Soft Wood	0.280	0.018	0.480

ABBREVIATED TERMS

C = Celsius	kgf = kilogram force
cm = centimeter	lbf = pound force
F = Fahrenheit	lbm = pound mass
ft = foot	mm = millimeter
gm = gram	m = meter
gmf = gram force	N = Newton
in = inch	ozf = ounce force
kg = kilogram	ozm = ounce mass



Useful Formulas

USEFUL FORMULAS

Required	Given	Formulas
Velocity or belt speed (V) in FPM	Pitch Diameter of pulley in inches & RPM of shaft	$V = .262 \times \text{P.D.} \times \text{RPM}$
RPM	Belt Speed or Velocity (FPM) P.D. of pulley in inches	$\text{RPM} = \frac{V}{.262 \times \text{P.D.}}$
P.D. of pulley in inches	Belt speed or Velocity (V) in FPM RPM of shaft	$\text{P.D.} = \frac{V}{.262 \times \text{RPM}}$
Horsepower (HP)	Force (F) in lbf. Belt speed or Velocity (V) in FPM	$\text{HP} = \frac{F \times V}{33,000}$
Horsepower (HP)	Torque (T) in lbf-in. RPM of shaft	$\text{HP} = \frac{T \times \text{RPM}}{63,025}$
Torque (t) in lbf-in.	Force (F) in lbf. Pulley radius (R) in. inches	$t = F \times R$
Torque (t) in lbf-in.	Horsepower (HP) RPM of shaft	$t = \frac{63,025 \times \text{HP}}{\text{RPM}}$
Torque (T) in lbf-ft	Horsepower (HP) RPM of shaft	$T = \frac{5,252 \times \text{HP}}{\text{RPM}}$
Force (F) in lbf	Horsepower (HP) Belt speed or Velocity (V) in FPM	$F = \frac{33,000 \times \text{HP}}{V}$
RPM of shaft	Horsepower (HP) Torque (T) in lbf-in.	$\text{RPM} = \frac{63,025 \times \text{HP}}{T}$
Effective Tension (Te) in lbf.	Torque (T) P.D. of pulley in inches	$T_e = \frac{2 \times T}{\text{P.D.}}$
Torque (T) in lbf-ft due to inertia	Inertia (WR ²) in lbf-ft. ² Initial RPM ₁ Final RPM ₂ Time in seconds (t)	$T = \frac{(\text{WR}^2) \times (\text{RPM}_2 - \text{RPM}_1)}{307.6 \times t}$
Inertia (J _S) System including Motor and Gear Drive	Motor Inertia (J _M) Ratio of Gear Drive (M _G) Load Inertia (J _L) Gear Drive Inertia (J _G) Related to Input Coupling Inertia (J _C)	$J_S = J_C + J_M + J_G + \frac{1}{M_G^2} J_L$
Inertia Matching	Above	$J_M : J_C + J_G + \frac{1}{M_G^2} J_L$

Horsepower And Torque

One (1) Horsepower (HP) = 33,000 foot pounds (lbf-ft) of work done in one (1) minute. Note that three (3) factors are involved:

- Distance (ft)
- Force (lbf)
- Time (min)

Putting it another way, one (1) HP is equivalent to raising 33,000 pounds, one foot in one minute horsepower can be determined by the following formula:

$$\text{HP} = \frac{L (\text{Load in lbf}) \times \text{Feet per minute}}{33,000}$$

To determine the relationship between horsepower and torque let:

- HP = Horsepower
- T = Torque in foot-pounds (lbf-ft)
- t = Torque in inch-pounds (lbf-in)
- N = R.P.M. (revolutions per minute)

Then, one (1) HP = A Torque (Twisting force) of 63,025 inch pounds, turning 1 revolution in 1 minute.

Therefore,

$$\text{HP} = \frac{t \times N}{63,025} \text{ or } \frac{T \times N}{5250}; t = \frac{63,025 \times \text{HP}}{N} \text{ or } T = \frac{5250 \times \text{HP}}{N}$$

Appendix

NEMA/IEC Frame Reference Dimensions

NEMA/IEC FRAME SIZES

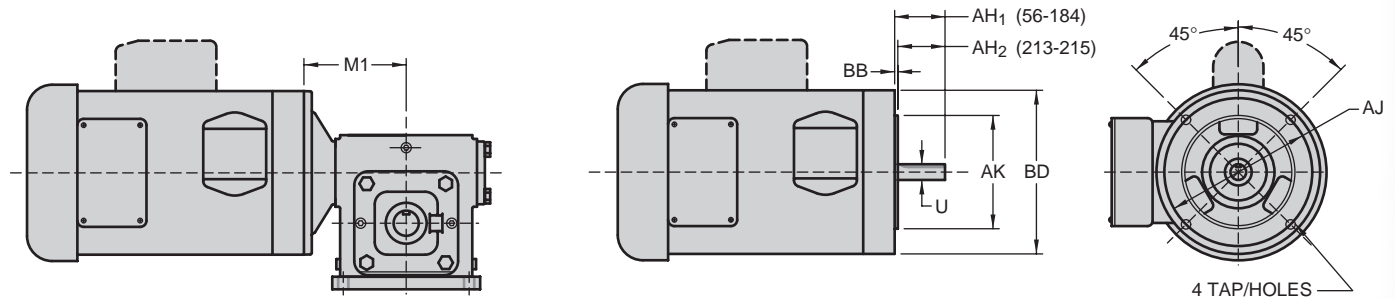

NEMA QUICK REFERENCE GUIDE

NEMA FRAME	U	AU ₁	AU ₂	AJ	AK	BB	BD	TAP
42	3/8	1-5/16	N/A	3-3/4	3	1/8	4-5/8	1/4-20
48	1/2	1-11/16	N/A	3-3/4	3	1/8	5-5/8	1/4-20
56	5/8	2-1/16	N/A	5-7/8	4-1/2	1/8	6-1/2	3/8-16
143T	7/8	2-1/8	N/A	5-7/8	4-1/2	1/8	6-1/2	3/8-16
145T	7/8	2-1/8	N/A	5-7/8	4-1/2	1/8	6-1/2	3/8-16
182	7/8	2-1/8	N/A	5-7/8	4-1/2	1/8	6-1/2	3/8-16
184	7/8	2-1/8	N/A	5-7/8	4-1/2	1/8	6-1/2	3/8-16
182T	1-1/8	2-5/8	N/A	7-1/4	8-1/2	1/4	9	1/2-13
184T	1-1/8	2-5/8	N/A	7-1/4	8-1/2	1/4	9	1/2-13
213	1-1/8	N/A	2-3/4	7-1/4	8-1/2	1/4	9	1/2-13
215	1-1/8	N/A	2-3/4	7-1/4	8-1/2	1/4	9	1/2-13
213T	1-3/8	N/A	3-1/8	7-1/4	8-1/2	1/4	9	1/2-13
215T	1-3/8	N/A	3-1/8	7-1/4	8-1/2	1/4	9	1/2-13

IEC B-5 FRAME QUICK REFERENCE GUIDE

IEC FRAME	U	AH ₁	AJ	AK	BB	BD	HOLE
63	11	23	115	95	3	140	9
71	14	30	130	110	3.5	160	10
80	19	40	165	130	3.5	200	11
90	24	50	165	130	3.5	200	12
100	28	60	215	180	4	250	14
112	28	60	215	180	4	250	14
132	38	80	265	230	4	300	14

IEC B-14 FRAME QUICK REFERENCE GUIDE

IEC FRAME	U	AH ₁	AJ	AK	BB	BD	TAP
63	11	23	75	60	2.5	90	M5
71	14	30	85	70	2.5	105	M6
80	19	40	100	80	3	120	M6
90	24	50	115	95	3	140	M8
100	28	60	130	110	3.5	160	M8
112	28	60	130	110	3.5	160	M8
132	38	80	165	130	3.5	200	M8

SIZE	42C-48C	56C-140TC	180TC	210TC
	M ₁	M ₁	M ₁	M ₁
E13	▲3.56	3.63	N/A	N/A
E17	4.06	4.06	N/A	N/A
E20	4.06	4.06	N/A	N/A
E24	N/A	5.38	5.38	N/A
E26	N/A	5.38	5.38	N/A
E30	N/A	5.56	5.56	N/A
E35	N/A	5.81	5.81	N/A
E43	N/A	6.63	6.63	6.63

▲56C adaptor only

NEMA KEY & KEYWAY DIMENSIONS

NEMA SHAFT	KEYWAY DIMENSIONS	
	(U)	(R) (S)
3/8	21/64	FLAT
1/2	29/64	FLAT
5/8	33/64	3/16
7/8	49/64	3/16
1-1/8	63/64	1/4
1-3/8	1-13/64	5/16

IEC KEY & KEYWAY DIMENSIONS

FRAME	D	G	F
63	11	8.5	4
71	14	11	5
80	19	15.5	6
90	24	20	8
100	28	24	8
112	28	24	8
132	38	33	10



Speed Reducer Specification Sheet

The worm gear reducer shall be made available with six input options and shall have the ability to be supplied with single and double reduction.

The input options shall consist of the following:

- Quill input adaptor to allow for connection to electric motors, utilizing a keyed hollow shaft suitable for direct attachment to a motor. The hollow motor input shaft shall be factory coated with an anti seize lubricant
- Coupled input adaptor to allow for the use of a flexible coupling to connect electric motors to the reducer.
- Hydraulic and servo motor input adaptors must be available.
- Non-Motorized and metric input adaptors must also be available.
- Solid input shafts shall be supplied with a key and can be used with a pulley and belt configuration.

The housings and covers shall be made of cast iron. All metal mating surfaces including, the input and output covers and motor adaptor flanges, shall be sealed with O-rings. The housings shall be designed with internal and external ribs and reinforced areas to handle the dynamic and static loads the reducers will experience during operation. Optional bolt on items such as bases, torque arms and brackets shall be made of steel.

The reducer and all add-on components shall be coated with an 8 mil (minimum) thick epoxy coating system. The epoxy coating shall have a minimum 60% solids loading when wet. Prior to coating, the reducer shall be prepared in a three stage hot iron phosphate dip process. The three stages shall consist of a hot iron phosphate dip, and rinse dip and a rust preventative dip. The coating system must be a 2 part, direct to metal, epoxy and must achieve an 8 mils dry thickness, minimum. The coating system shall exceed a 1,000 hour salt spray test per ASTM B-117 with no signs of degradation.

The input worm gear shall be made of alloy steel that is case hardened to a minimum Rockwell-C (RC) of 58.

The reducer shall be equipped with a vent that can be opened or closed by the operator. The vent shall have a labyrinth design to prevent high pressure wash down liquid from entering the reducer. The vent shall be made of black industrial duty, injection molded DuPont™ Zytel® Nylon with UV protection.

The reducers shall be filled and shipped with Mobil Glygoyle 460 polyalkylene glycol (PAG) synthetic lubrication (exception for Drywell reducers). The lubricant shall conform to NSF H1 (formerly USDA) certification. The bearings and reducer gears shall be splash lubricated.

Tapered roller bearings shall be utilized on the output shaft and either tapered roller or ball bearings shall be used on the input shafts. The bearings shall provide a minimum of 10,000 (or 6,250 L₁₀) hour average life. A crush ring shall be utilized to ensure the proper positioning of the output shaft taper roller bearings. The use of the crush ring allows for the automatic setting of the end play, 0" to 0.002", of the taper roller bearings.

The reducers with quill input adaptors shall include hydrogenated acrylonitrile butadiene rubber (HNBR) or fluoroelastomer (aka Viton®) seals on the input shaft. The seals shall have a minimum temperature range of -40 to 300°F (-40 to 149°C). Shafts are to be center ground and then plunge ground to provide a seal surface of 16 to 20 micro inches Ra.

Reducers shall not include any silicon rubber of any type.

Fasteners shall be a minimum of Grade 5 except for the base mounting bolts shall be a minimum of Grade 8.

The reducer shall be supplied with multiple drain, fill and vent holes located in manner that facilitates maintenance and ventilation. The multiple holes allow for the reducer to be installed in all possible mounting positions including worm low. The drain and fill holes shall be shipped with threaded pipe plugs installed that are coated with a sealant and thread locking compound. The plugs shall be square head external type.

All reducers must be air pressure tested with a mass flow tester at 8 psi prior to shipment with no leak paths evident.

Motor adaptor flanges shall have threaded push off holes to facilitate the removal of motors. The holes shall have cast iron reinforcing boss pads that have minimum 1.5 times the number of threads than the hole diameter.

All hollow shaft models shall be supplied with symmetrical output shafts. The output shafts shall have puller slots machined into them to allow for removal of the reducer from the mounting shaft. The slots are designed for use with a hub puller. The hollow shafts shall have two (2) set screws set 65° apart to allow for maximum torque gripping transfer. Stainless steel output shafts shall be made available upon request.

Notes

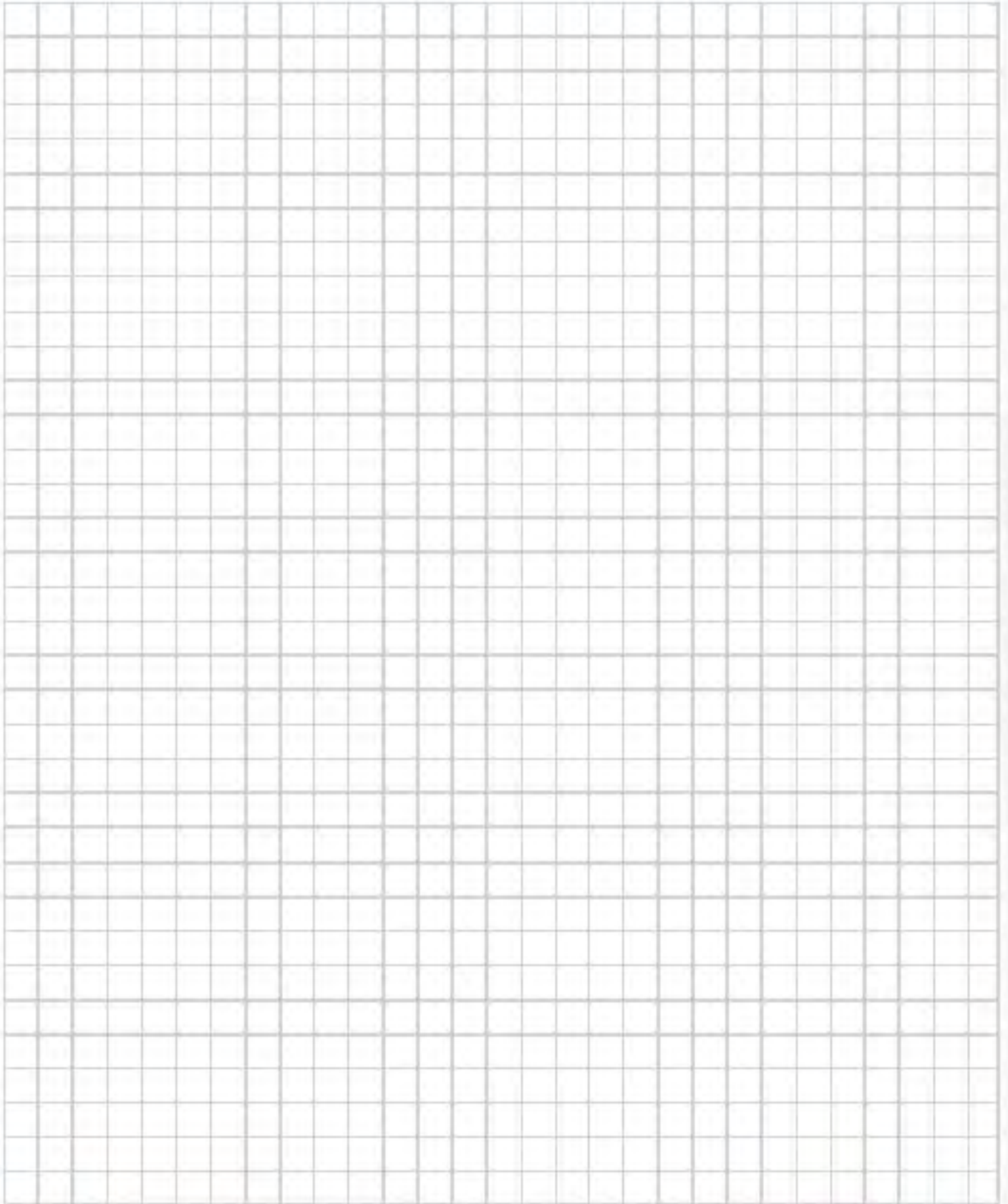

Notes

VELOCITY
1 1 1

Appendix

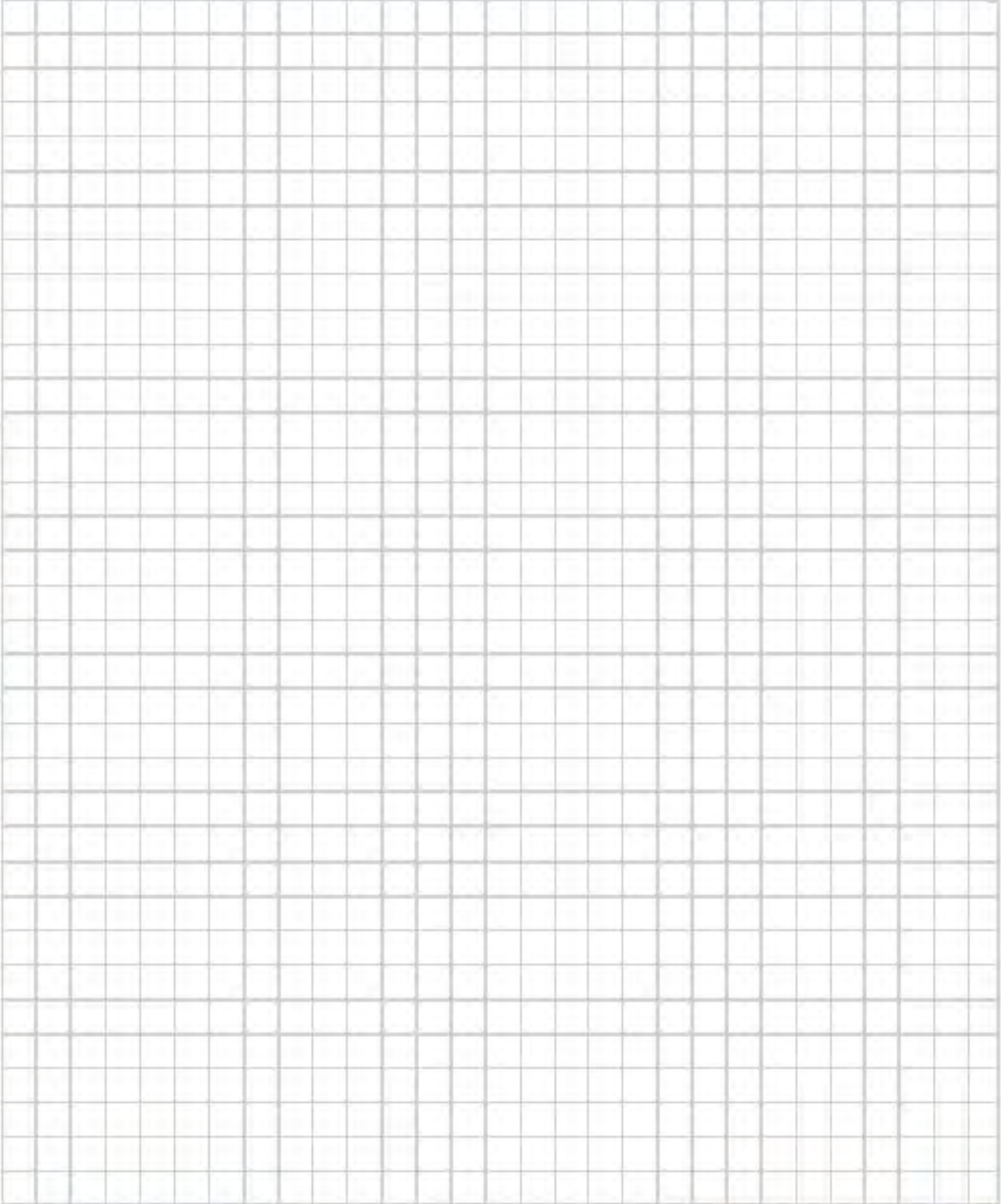

Warnings And Cautions



WARNING

Warnings

Winsmith products, and associated equipment and machinery, are intended for selection and use by trained and skilled persons capable of determining their suitability for the specific application or use. Proper selection, installation, operation and maintenance, including implementation of adequate safety precautions, are the responsibility of the purchaser or user. The following safety precautions, as well as additional safety precautions that may be required for the specific application or use, are the responsibility of the purchaser or user. **FAILURE TO OBSERVE REQUIRED SAFETY PRECAUTIONS COULD RESULT IN SERIOUS INJURY TO PERSONS OR PROPERTY OR OTHER LOSS.**

Lock-out/Tag-out

It is **EXTREMELY IMPORTANT** that equipment or machinery does not unexpectedly start. To prevent this possibility, all electrical or other input power sources must be turned off, and properly locked out. Tag out procedures must be followed before working on or near the reducer or any associated equipment. Loads on the input and output shafts should be disconnected prior to working on any reducer. Failure to observe these precautions may result in serious bodily injury and/or property damage.

Grounding

Be sure the unit and associated equipment are properly grounded and otherwise installed in accordance with all electrical code requirements.

Protective Guarding / Loose Clothing, etc.

Always insure there is proper protective guarding over all rotating or moving parts. Never allow loose clothing, hair, jewelry and the like to be worn in the vicinity of rotating or moving parts or machinery. The purchaser

or user is responsible for complying with all applicable safety codes. Failure to do so may result in serious bodily injury and/or damage to property or other loss.

Selection & Installation

This reducer and associated equipment must be selected, installed, adjusted and maintained by qualified personnel who are knowledgeable regarding all equipment in the system and the potential hazards involved.

Consult Catalog Ratings.

Load, torque and other requirements must not exceed the published ratings in the current catalog and/or on the speed reducer nameplate, and the reducer selected must be consistent with all service factors for the application. See Winsmith catalogs and www.WINSMITH.com.

Brake Torque Loads.

Whenever a brake or any other stopping force is involved in an application, braking torque loads imposed on the gear reducer must not exceed the allowable load ratings.

Not a Brake

Speed reducers should never be used to provide the function of a fail safe brake or an assured self locking device. Speed reducers must never be used to replace a brake or a critical braking application function.

Excess Overhung Loads

Excessive overhung loads on the input or output shafts of a gear reducer may cause premature fatigue failures of the bearings and/or shafts. Mount gears, pulleys and sprockets as close to the housing as possible to minimize such loads. Do not exceed catalog ratings.

Excess Thrust Loads

Excessive thrust loads on the input or output shafts of a gear reducer may cause premature failure of bearings. Do not exceed catalog ratings.



Warnings And Cautions (cont.)

WARNING

Alignment

Properly align any input and output power transfer elements connected to the speed reducer. Even slight misalignments in a rigid mounting system may cause binding, large vibration forces or excessive overhung loads, leading to premature bearing, shaft, or speed reducer failure. Use of flexible couplings that allow the reducer and connected transfer elements to self-align during operation will compensate for minor misalignments.

Not a Support Structure

A speed reducer must never be used as an integral component of a machine superstructure or support frame that would subject it to additional loads other than properly rated loads transmitted through the shafts.

Mounting Position

Your Winsmith gear reducer should be mounted in one of the mounting positions shown in the catalog. Different mounting positions should not be used without contacting Winsmith as this may result in improper lubrication.

Overhead Mounting

Mounting of a speed reducer in overhead positions may be hazardous. Use of external support rails or structure is strongly recommended for any overhead mounting.

Lifting Eyebolts

Any lifting supports or eyebolts provided on the gear reducer are supplied with the purpose to vertically lift the gear reducer only, without any other attachments or motors. Inspect such supports and bolts before each use.

Properly Secure Mounting Bolts

Proper mounting bolts and proper torques must be applied and maintained to insure the gear reducer is securely mounted to the desired machinery. Inspect regularly as machine vibration may loosen fasteners.

Thread Locking Compound

Proper thread locking compound should be appropriately applied to the cleaned threads of all mounting bolts connecting or securing the speed reducer to equipment and any drive, accessories, or brake components attached to the speed reducer. If at any time after installation a factory supplied assembly or

construction bolt is removed, care must be taken to thoroughly clean off the old thread locking compound and a new appropriate thread locking compound must be applied. Failure to properly apply new thread locking compound on all mounting or reducer construction bolts may result in serious injury or death from falling mechanical components.

Reducer Surface Is Hot

Operating gear reducers generate heat. Surface temperatures may become hot enough to cause severe burns. Proper personal protective equipment should be used.

Noise

Operating gear reducers may generate high noise levels. Use appropriate hearing protection and avoid extended exposure to high noise levels.

Lubricants Hot and Under Pressure

The temperature of lubricants inside a gear reducer may be very high. The reducer should be allowed to cool to ambient temperature before removal of any vent, drain, level, or fill plugs, and before removing seals or bearing covers. Gear reducers without a pressure vent may also be under great internal pressure. Slowly loosen the lubricant fill plug above the lubricant level to vent any internal pressure before further disassembly.

Lubricant Contact

Contact with lubricants can present safety concerns. Proper personal protective equipment should be used whenever handling speed reducer lubricants. Consult the lubricant MSDS sheet which is often available on the lubrication manufacturer's website.

FDA, USDA, and NSF Applications

Factory supplied lubricants may not be suitable or safe for applications involving food, drugs and similar products. This includes applications subject to FDA, USDA, NSF or other regulatory jurisdiction. Consult the lubricant supplier or Winsmith for acceptable lubricants.

Inspection and Lubrication

Regularly inspect the gear reducer to ensure it is properly operating, and follow the all maintenance, operation and lubrication guidelines provided.

Terms And Conditions Of Sale

ENTIRE AGREEMENT

The parties agree that there are no understandings, agreements or representations, express or implied, not specified herein, respecting this offer or sale, and that this instrument contains the entire agreement between Seller and Buyer. No prior waiver, course of prior dealing or usage of the trade shall be relevant to supplement or to explain terms used in this agreement.

CONTROLLING TERMS

All sales are expressly limited to, and the rights and liabilities of the parties shall be governed exclusively by, the terms and conditions herein. In the event any purchase order or offer from Buyer states terms additional to or different from those set forth herein, this document shall be deemed a notice of objection to such additional or different terms and a rejection thereof. Any acknowledgment or shipment of product by Seller to Buyer subsequent to Seller's receipt of a purchase order or offer from Buyer shall not be deemed to be an acceptance by Seller of an offer to contract on the basis of any Buyer's terms and conditions. Receipt and acceptance by Buyer of products shall be conclusive evidence of Buyer's acceptance of the terms and conditions set forth herein as the sole controlling terms and conditions of the contract between Seller and Buyer. Stenographic and clerical errors by Seller are subject to correction.

ACCEPTANCE OF ORDERS

Seller possesses the exclusive right to accept or refuse any and all orders. No bid, offer, or quotation shall be valid or binding upon Seller, and no order shall be accepted and no sale shall be final, until such bid, offer, quotation, order or sale shall be acknowledged in writing by Seller. See price pages for minimum order amount.

PRICES

All prices are subject to change without notice and shall be adjusted to the Seller's prices in effect on the date of shipment. Prices reflect standard packaging for domestic shipment only. All prices are in U.S. Dollars. All tooling and equipment Seller produces or acquires for purposes of filling this order shall remain property of Seller. All intellectual property associated with the products shall remain the sole property of Seller.

DELIVERY

Delivery dates are estimates and not a guaranty of a particular day of delivery and are based on the prompt receipt of all necessary information from the Buyer. Seller shall not be liable for failure or delay in shipping goods hereunder if such failure or delay is due to an act of God, fire, flood, war, labor difficulties, accident, strikes, lockouts, civil disorders, governmental priorities or embargoes, inability or difficulty in obtaining raw materials or supplies at customary terms and prices or any other causes or failure of presumed conditions of any kind whatsoever which are either beyond the reasonable control of the Seller or which would make impracticable the fulfillment of Seller's obligations hereunder. Buyer shall not refuse to accept deliveries so delayed. Seller shall be compensated for any and all extra costs and expenses occasioned by delays attributable to Buyer.

TRANSPORTATION AND RISK OF LOSS

All shipments are freight collect unless eligible for a freight allowance expressly set forth in current price sheets or on the face hereof. Seller reserves the right to select the method and type of transportation. If a method of transportation other than that selected by Seller is requested by Buyer, excess packing, shipping and transportation charges resulting from compliance with Buyer's request shall be for the Buyer's account. All shipments are F.O.B. point of shipment and risk of loss shall pass to Buyer after products are delivered to carrier. Claims for damage or loss in transit must be filed by Buyer against the carrier.

CANCELLATION OR MODIFICATION

Buyer may not cancel or modify any order, either in whole or in part, without Seller's prior written consent and then only upon payment to Seller for all applicable costs incurred by Seller, including, without limitation, costs of materials, labor, equipment and supplies, and for lost profits on cancelled or modified orders. Order changes or additions received after original order has been processed will be treated as a new order.

TAXES

Any taxes which Seller may be required to pay or collect with respect to the sale, delivery or storage of the products, including taxes upon or measured by the receipts from the sales thereof, shall be for the account of Buyer who shall promptly pay the amount thereof to Seller upon demand, or in lieu thereof, furnish Seller with a tax exemption certificate acceptable to the taxing authorities.

WARRANTY AND DISCLAIMER

Seller warrants that its products shall be free from defects in material and workmanship under normal use and service for a period of 24 months from date of shipment. On equipment and materials furnished by Seller but manufactured by others, Buyer shall accept in lieu of any liability or guarantees on the part of Seller, the benefits of guarantees as are obtained by Seller from such manufacturers or vendors. SELLER MAKES NO WARRANTY OF MERCHANTABILITY OR FITNESS FOR A PARTICULAR PURPOSE OR ANY OTHER WARRANTY, EXPRESS OR IMPLIED, EXCEPT AS IS EXPRESSLY SET FORTH HEREIN. Failure by Buyer to object to or reject products or materials delivered hereunder, in writing within 30 days from the date of shipment of the products or materials, shall constitute an acceptance and waiver by Buyer of all claims hereunder on account of alleged errors, shortages, defective workmanship or material, breach of warranty or otherwise, discoverable upon inspection by Buyer.

LIMITATION OF LIABILITY

Buyer's exclusive remedy on any claim of any kind for any loss or damage arising out of, connected with, or resulting from this contract, or from the performance or breach thereof, or from the design, manufacture, sale, delivery, resale, or repair or use of any products covered by or furnished under the contract, including but not limited to any claim for breach of warranty, negligence, strict liability or other tort, shall be the repair or replacement, F.O.B. Seller's factory, as Seller may elect, of the product or part thereof giving rise to such claim, except that Seller's liability for such repair or replacement shall in no event exceed the contract price allocable to the product or part thereof which give rise to the claim. SELLER SHALL IN NO EVENT BE LIABLE FOR DIRECT, INDIRECT, INCIDENTAL OR CONSEQUENTIAL DAMAGES.

RETURN OF MATERIAL

Seller's permission must be obtained in writing before any products are returned to it by Buyer. If products are returned without such permission, Buyer authorizes Seller, in addition to such other remedies as it may have, to hold the returned products at Buyer's sole risk and expense. All returns must be freight prepaid by Buyer. Seller will in no event accept the return of any product that upon return is in the opinion of Seller altered, damaged, used, or in other than first class salable condition.

INDEMNITY

Buyer agrees to indemnify, defend and hold harmless Seller from any claims, loss or damages arising out of or related to Seller's compliance with Buyer's designs, specifications or instructions in the furnishing of products to Buyer, whether based on infringement of patents, copyrights, trademarks or other rights of others, breach of warranty, negligence, strict liability or other tort.

PAYMENT

All invoices are due net 30 days from date of invoice unless otherwise specified by Seller. If at any time Seller deems itself insecure from any cause whatsoever, including but not limited to adverse changes in Buyer's financial condition or impairment of Buyer's credit, Seller may in its sole discretion stop delivery of goods, require advance payment for goods, and/or declare immediately due all indebtedness owed to Seller including amounts due hereunder. Payments not made when due shall bear interest at the prime rate plus 5% per annum or, if lower, the highest rate legally permissible, until paid. Credit balances will be applied against future purchases only and must be claimed within one year of creation or are waived.

GOVERNING LAW AND ARBITRATION

Any dealings or contract between the parties shall be governed by and construed in accordance with the law of the state of Ohio, excluding its choice of law provisions. Buyer and Seller agree that any action, suit or proceeding arising hereunder or related hereto may be brought in any state or federal court of competent jurisdiction sitting in the State of Ohio and each party submits to the jurisdiction of such courts. Either Buyer or Seller may elect to have any controversy arising under or in any way related to the subject matter hereof decided by arbitration by a single disinterested arbitrator in Columbus, Ohio, U.S.A., in accordance with the commercial rules of the American Arbitration Association then obtaining. The fee for the arbitrator shall be shared equally by the parties. Each party shall bear its own costs and expenses, including attorneys fees.

Revised 06/01/08

Reprinted 06/08



2D DRAWINGS & 3D MODELS
www.WINSMITH.com



Winsmith History

Winfield H. Smith founded Winsmith in 1901 and it has been a technology leader in geared speed reducer products for over 100 years. The company began operations in Buffalo, New York but moved to their current location South of Buffalo in the 'lake effect snow belt' of Springville, New York. Winsmith's history for product design innovation began with the new introduction of gear driven revolving display tables for the emerging concept department store window displays. Additionally, Winsmith developed worm gear drives for ice cream freezers.

During the 1920's, Winsmith was one of the very first companies to introduce the concept of a totally enclosed standard worm gear reduction product line. These initial "A Line" products were soon superseded with a "B-Line" product offering in the early 1930's and then again surpassed by "C-Line" product designed in the mid-1950's. Today, C-line products are still in use throughout the world.

Winsmith consistently provides customers with high value products by combining product line innovation and value engineering as one continuous process. Over the past 28 years, this philosophy has driven the unprecedented introduction of seven new worm gear product lines, each providing increased value and power density.

During the 1970's, Winsmith increasingly developed custom gearing designs with unique capabilities. Examples of various custom gear products have included the supply of all the ASR-9 (FAA Airport aircraft approach radar) tracking drive systems now in use at every major US airport; all tracking drives for the NOAA Nexrad Doppler weather radar systems throughout the world; the drives for ice cream machines found in every Dairy Queen® in the world.

Since that time, Winsmith has designed and produced a wide range of extremely modified and totally custom geared speed reducer products involving many different gearing technologies including worm, planetary, differential planetary, planocentric, epicyclical, and helical gearing. Today, these custom gear product development and production capabilities serve a wide range of applications including broadband satellite communications, solar energy array tracking, hydro flow generation, motion control, and aerial swing boom man lifts.

Winsmith production consist of three gearing manufacturing operations; each with unique capabilities. The Springville, NY, operation produces all the "legacy products," high precision motion control drives, and low volume custom products. The Gainesville, GA, operation produces a wide range of higher volume industrial products. The Asheville, NC operation produces high volume products, marketed under the **PERFECTION GEAR** brand, that serve the aerial man-lift and crane swing boom drive markets. Since 1998, all of Winsmith's plant operations are ISO 9001 certified and are also capable of complying with various MIL specifications including complete parts traceability. Winsmith has active lean six sigma programs in all plant operations.

Winsmith's district sales offices are located throughout North America and staffed with over 100 people who provide a high level of local product application expertise, product support, and product service.

Winsmith's history and continuing core focus provide customers with the very best value industrial worm gear reducer products. This focus is supported by an organizational commitment to quality, continuous improvement, and responsiveness to customer delivery and application requirements.

Peerless Winsmith, Inc. is a subsidiary of **HBD Industries, Inc.** HBD manufactures quality, application-engineered custom designed and standard industrial products serving many diverse industries and markets. Products manufactured by HBD and its subsidiaries include AC/DC/BLDC electric motors, aerospace precision components, budding strips, cemented tungsten carbide parts, closed die forgings, coated rubber fabrics, conveyor belting, drives, ducting, gear reducers, hose (automotive, aviation, hand-built, industrial, marine and petroleum), material handling equipment (metal separators/detectors and electro-magnetic lifting equipment), power transmission belts, rubber bands, rubber roll coverings and ventilation equipment (fans and blowers). For complete details on **HBD Industries, Inc.**, log onto www.hbdindustries.com.





Speed reducer models available in

3D



For details and 3D downloads, visit

www.WINSMITH.com



SE ENCORE™

Unique, Powerful Performance



DISTRIBUTED BY:



PEERLESS-WINSMITH, INC.

SUBSIDIARY OF **HBD INDUSTRIES, INC.**

172 EATON STREET, SPRINGVILLE, NY 14141-1197

PHONE: 716/592-9310 • FAX 716/592-9546

WEBSITES: www.WINSMITH.com

www.hbdindustries.com



SE Encore Catalog - 2008

PWS-19569

Printed in U.S.A.