

**SEAL STRENGTH AND PACKAGE INTEGRITY –  
The Basics of Medical Package Testing**

***Stephen Franks  
TM Electronics, Inc.***

## Part 1: Seal Strength Testing

The objective of package testing for medical packages is twofold: first, to ensure the integrity of the sealed package, and second, to assure that no weaknesses in the sealed areas of the package permit leaks to develop during sterilization, normal handling, transportation and storage. Testing of a medical package must yield a comprehensive view of its ability to provide and maintain a sterile barrier around the medical device or product. According to ANSI/AAMI/ISO11607-1997 *Packaging for terminally sterilized medical devices*, both seal strength testing and package integrity testing are needed in order to properly validate your design and document your conformance to specifications. In this article we will look closely at seal strength testing.

Seal strength testing evaluates the mechanical strength of the seal, assuring proper bonding to maintain **package integrity** throughout the life of the package. Package integrity implies the maintenance of the sterile barrier property of the package. It is important to understand that *seal strength* and *package integrity* are distinctly separate objectives of the package testing process.

Seal strength is a package attribute; data acquired can be used to validate the package design as adequate for maintenance of integrity, to monitor process performance, and to confirm shelf life performance. The seal strength also provides assurance of control of the “peelable” characteristic of the package. There are two basic types of seal strength testing addressed in ISO-11607: tensile strength testing and burst or creep (inflation) testing.

Tensile seal strength testing (ASTM F88) uses a defined width sample (25.4mm) of the package seal perimeter. A jaw moving at a defined constant rate 10 to 12 in/min. pulls the seal apart while measuring the resistance force during seal separation. A typical seal strength plot is shown in Figure 1.

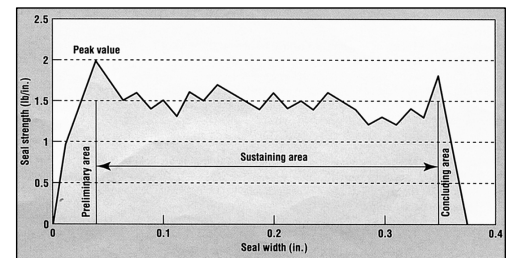

Figure 1: Typical tensile strength test plot

This test is particularly applicable to peelable medical package seals. It has the advantage of determining the force required by the end user to open a peelable package as well as providing force data that can be used in validation and control of the sealing process. Interpretation of the tensile seal strength result and plot is an important factor in reporting results. The resultant plot may show a higher peak force on the initiation of the test followed by a relatively constant force region during the peel apart of the seal and may be concluded with another higher peak. It is vital to the test result interpretation that the test report include the region of measurement; that is, peak initial force, sustaining region force or average energy (area under the curve). More help in interpreting the results can be found in ASTM F-88.

Another important reporting factor is the configuration of the sample support. Samples may be run with a free or supported seal, called a tail (see Figure 2). Both methods are acceptable but it is important to note that the stress/ strain curves or results are NOT equivalent. In the “free tail” method, the angle of peel is constantly varying from 90 degrees to greater than 90 degrees. In the “supported tail”, the tail is restrained by the use of a fixture to keep the angle of peel at

180 degrees. The force result will vary depending on the support condition. Test results cannot be compared for different support conditions.

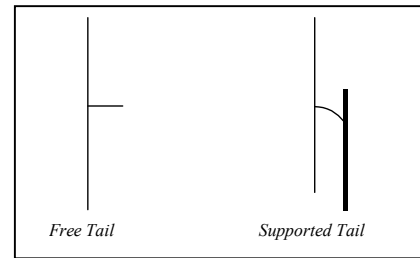

Figure 2: “Free” vs. “Supported” Tail Tensile Test Design

The tensile seal strength test is a valuable testing tool for seal evaluation. Its limitations are that only single sections of a seal are evaluated at one time, thus not providing information on whole package integrity and the process of testing is relatively slow for process control considerations. Its strengths are specific force results for peelable packages and wide usage within the industry.

*Inflation Seal Strength Testing (ASTM F1140 and F2054)*, including burst, creep and creep-to-failure testing, requires pressurizing the entire package and measuring the peak rupture pressure (burst test) or the time to failure at a constantly held pressure (creep and creep-to-failure test). These tests provide a whole-package minimum seal strength and are equally applicable to peelable and non-peelable seals. Inflation tests are applicable to most package forms such as pouches, header bags, lidded trays, flexible or rigid blisters and laminated or rolled tubes.

Although no universal mathematical relationship has been defined between inflation and tensile seal strength tests, research has been done on pouch forms that establishes a good correlation between restrained plate inflation testing – discussed later in this article – and tensile testing in locating the minimum seal strength area. (Franks, Stephen H. and Donald S. Barcan. “Examining the Relationship of Tensile and Inflation Seal Strength Tests in Medical Pouches”. © 1999, Donbar Industries, Inc. & TM Electronics, Inc.).

### Burst Test

Whole package inflation tests are categorized as *burst tests, creep tests or creep-to-failure tests (ASTM F1140 or F2054)*. To perform a burst test, a package is inflated at a uniform rate until the seal separates at the point of greatest weakness. The burst test is a peak inflation pressure test. It is a variable test; the variable is the back pressure inside the package at the instant of seal rupture. Figure 3 is a graphic plot of a burst test provided by the TM Electronics BT-1000 Package Tester, showing the characteristic burst curve. In this illustration, the tested part burst at a pressure of 176.0 In H<sub>2</sub>O. The burst pressure result is a variable statistic that can be utilized to document process development and process control through the use of tools such as upper and lower control limits.

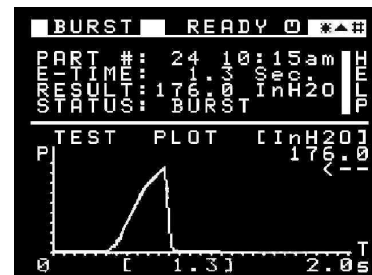

Figure 3: Burst Test Graph

In the burst test, air is introduced into the package at a predetermined pressure and flow rate (see Figure 4). Control of inflation rate is important in a burst test to ensure consistent conditions for the test method, similar to the tensile test method. The porosity (or lack thereof) of the package material determines the inflation rate for the burst test. Because air escapes through the walls of a porous package during inflation, the flow rate must be increased to compensate for the lost air through the walls and create the back pressure in the porous package. This pressure creates the force to rupture the seal.

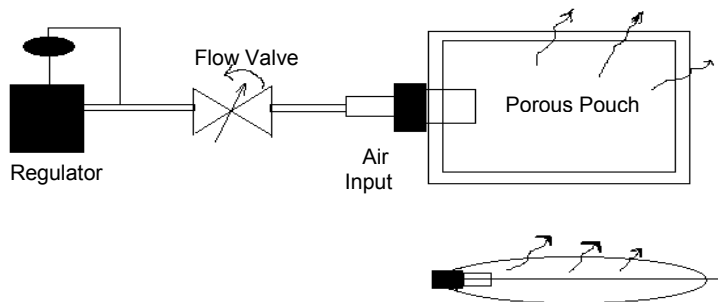

Figure 4 – where does inflation pressure come from?

Limitations of the burst test are that package characteristics will vary the resultant value. For example, the character of the seal itself is a factor; peelable seals will part under a lower pressure than the non-peelable seals found in formed packages. The size of the package will influence the resultant value; burst values of a large package will be lower than that of a smaller package. Unrestrained packages

may have material failures before the seal fails. These issues are not a factor when testing a single style package with consistent methodology and are offset by the speed of the test, which provides access to process data in seconds. The burst test does not require sample preparation and can be run with minimum operator training.

### Whole Package Creep Tests

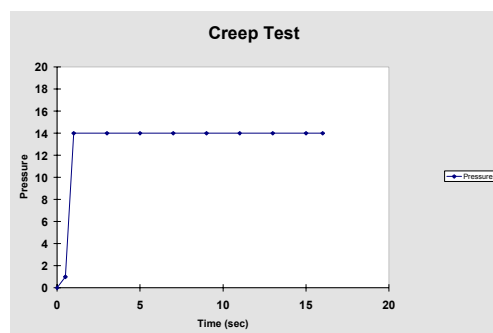

Figure 5: Typical Creep Test Plot

The Creep Test is a second general type of whole package inflation seal strength test. In the Creep Test, a whole package is inflated to a constant pressure, which is then held for a specified time, resulting in a pass/fail result (see Figure 5). Early users of the method for peelable seals used the test as an analogy for the pressure difference on the seals seen in the ETO sterilization and air transport cycles. The Creep test provides a test for slow shear of the adhesive bond similar to a dead weight hanging on the seal. It is

important to first determine the burst strength of the package; a suggested starting pressure for peelable

seals in ASTM F1140 is to begin evaluating your seal with a creep pressure that is about 80% of the burst value. Different seal adhesive systems may require a lower creep test pressure to be effective, for example, pressure sensitive adhesives. Inflation rate of the test is not critical as long as the initial fill is not so fast to shock the seal or too slow to cause an effectively longer test time.

Shortcomings of the Creep Test include the need for the operator to visually examine the seal at the end of the test to declare the amount of seal peel for process control and the lack of a variable statistic upon which to perform process control analysis.

The Creep-to-failure Test (CTF) is a variation on the Creep Test that addresses these weaknesses. In the Creep-to-failure Test, the test pressure on the inflated package is held until the seal actually fails, yielding an end point value (a variable statistic), *time to failure*, and pinpointing the area of greatest weakness in the seal (ASTM F1140 method b2). Time to failure can then be used in SPC or SQC methods.

To achieve sensitive, repeatable results using both burst and creep inflation tests, test equipment must be used that takes into consideration the configuration of the package.

Completely sealed packages need an access probe to inflate the package. This probe may require reinforcement to prevent material splitting at the entry point. Open pouches (sealed on only three sides) are sealed with a mechanical clamp to pressurize the three formed pouch seals. Figure 6 illustrates one method of closing an open package for seal strength testing as well as a device designed to provide reinforced and a leak-tight air path into a completely sealed package.



Figure 6: Open package test fixture (above); "Package Port" leak-tight entry (right)

Inflation seal strength testing on unrestrained packages, ASTM F1140, provides a fast and effective method of evaluating package seal strength. A shortcoming of this method is that there are no specific standards for a package's inflation seal strength, since the seal strength values are relative to the packagesize, geometry, materials and bonding agents, although tests have proven over time to provide consistent process data on a package that is tested under consistent, repeatable conditions. In addition, shortcomings of the unrestrained method are recognized for geometry effects of the package on the interpretation of test results. For example, pouches with a long side seal will generally fail on the long seal unless a heater failure has occurred on the shorter seal or chevron. Unsupported tray lid seals may fail at points only relative to their geometry. Very flexible package materials may deform with pressurization to an extent that makes seal testing difficult. To address these problems, it may be advisable to use restraining plates for your inflation testing.

*Restrained Package Testing (ASTM 2054)*

So far we have discussed seal strength testing of packages unrestrained in any axis (ASTM F1140). *Restrained package testing* is a refinement that has several advantages: it has been shown in pouches to define the minimum seal strength area more consistently, provides more consistent loading on the package seal, and incidentally correlates well with tensile seal strength tests in defining the minimum seal strength area.

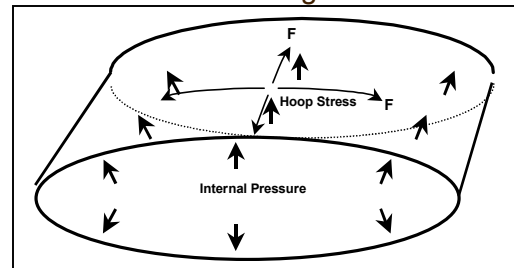

Figure 7a: Circumferential Hoop Stress

The geometry of the package under test affects the distribution of internal pressure forces on the package surface and seals. A pouch-form package unrestrained in any axis exhibits circumferential hoop stress when internal pressure is applied (Figure 7a). When the package is restrained, the load application is distributed directly on the seal area, and, because material stretching and deformation is minimized, the test forces are more uniformly applied (Figures 7b and 7c).

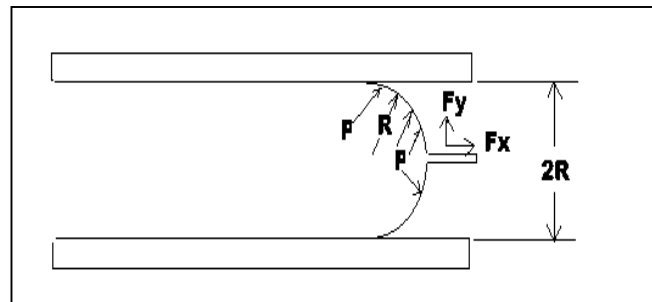

Figure 7b: Restrained plate test forces (bags)

In addition, package restraint has a direct relationship to burst pressures: the wider the gap between restraining plates, the lower the average burst pressure, with unrestrained packages yielding the lowest burst pressure of all (figure 7d). The most important factor in the interpretation of results is that all conditions in the package test method are

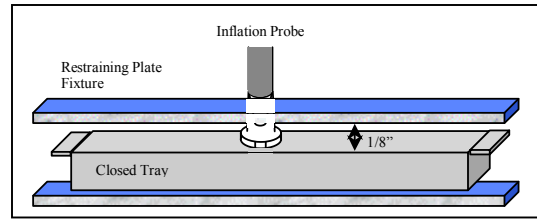

Figure 7c: Restrained plate test forces (trays)

consistent. One must not compare results of different packages or different test conditions on the package, such as restraining plate gap, when analyzing data. Establish a set of test conditions for each package and reproduce those conditions consistently.

Figure 8 illustrates a restrained package fixture. Use of package restraints must be approached with caution; because of pressures exerted on the plates, extreme care must be taken that fixtures are designed to withstand the forces applied by the inflated package (Franks, Stephen. "Calculating Factors of Safety for Package Burst and Creep Test Fixtures". *Medical Device & Diagnostic Industry*, June, 1998).

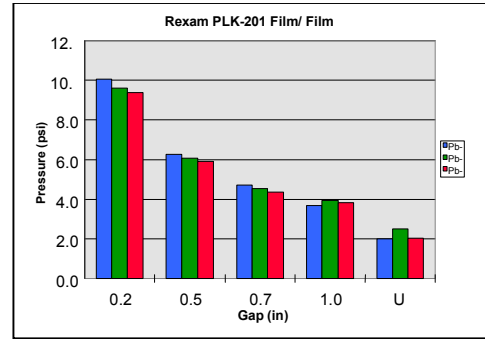

Figure 7d: Plot of Burst Pressure vs. Gap

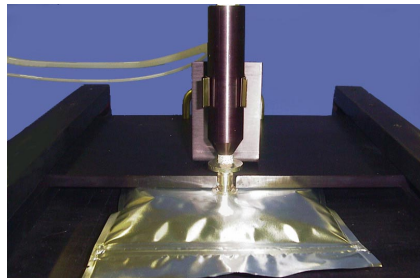

Figure 8: Pouch in restraining fixture

Inflation seal strength test results provide an excellent tool for process control. Inflation Burst test results, creep-to-failure and tensile data are all amenable for use in control charts, and provide quantitative data required by ISO-11607 for package validation. Furthermore, ASTM test methods ASTM F88, Standard Test Method for Seal Strength of Flexible Barrier Materials and ASTM F1140, Standard Test Methods for Failure Resistance of Unrestrained and Nonrigid Packages for Medical Applications, are accepted FDA Consensus Standards. ASTM F2054, Standard Test Methods for Burst Testing of Flexible Package Seals Using Internal Pressure within Restraining Plates, has been submitted for FDA acceptance.

But this is only half of the story. Seal strength testing is only one part of the ISO-11607 recommendations; *Package Integrity Testing* is the other part. In the concluding chapter of this series we will look at various methods of **physical package integrity testing**.

## Part 2: Physical Package Integrity Testing

The previous chapter tried to clearly separate and define the need to measure both seal strength and package integrity. Seal Strength, the mechanical strength of the seal, provides a measure of the ability of the package to maintain its sterile barrier through sterilization, processing and transport to the customer. Package integrity is purely a measure of the package's sterile barrier. The definition from ISO-11607 is: "the unimpaired physical condition of the final package".

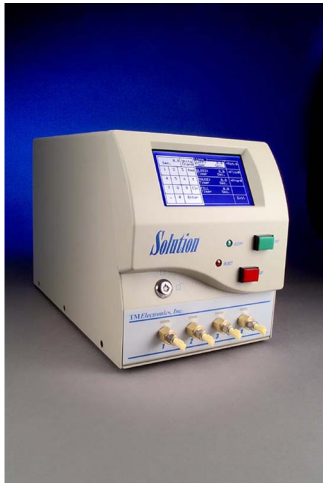

The TME SOLUTION™ Leak and Flow Tester provides quantitative pressure decay test results for SQC or SPC.

Over the past five years the medical device industry has worked with the FDA by providing test data to move away from biological challenge testing of finished sterile medical device packages and toward physical test methods for measuring package integrity. From a practical standpoint, package integrity is measured by package "leakage". Leakage can be a result of large holes, pinholes or cracks in package materials or can be the result of seal bonding or disrupted seals. Either fracture type represents the potential for bacterial (bioburdened) contamination and loss of the product's sterile nature. The physical test methods, therefore, are designed for identifying these material or process failures.



The current questions of merit for the industry concern what size or type of leak path will allow some bioburdens to actually contaminate a packaged product. No data are currently available that define this issue. However, prior studies by (HIMA) indicate that high bio-burden aerosol tests cannot reliably indicate leakage in a package with up to 1/8" gaps (see *MD&DI* – August/September 1995). Recent literature (Hackett, *Pharmaceutical and Medical Packaging News*, July 2000) indicates that the nature of flow and the mobility of the bacterial

species may in fact make penetration difficult up to 25-50um holes. Because physical test methods are more reliable, more repeatable and can be verified by laboratory repeatability and reliability studies, these methods present the best opportunity for determining the integrity of the medical package.

Several physical test methods are described in industry guidance such as ISO-11607 and FDA "Consensus Standards". Other methods have been or are being documented in the ASTM F2.3 and 2.6-6 Committees on Flexible Packaging. Still other methods are available by individual test equipment manufacturers. Table I provides a sample of these methods.

There are several factors to consider when choosing an integrity test. While obviously test sensitivity, i.e. the size of the hole detectable, might seem a principal consideration, striving to find 0.2µ holes may not be necessary or economical. In addition, medical package integrity tests are divided principally by package material requirements. Medical packages can use either non-porous materials such as films, co-extrusions or laminates including foils. They also can use porous materials such as Tyvek® or papers for some part of the package barrier wall. The porous materials are predominant in the industry due to the extensive use of ETO sterilization methods. The methods and equipment for porous package testing may be limited by the nature of the material.

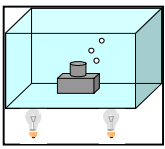
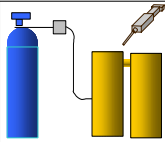
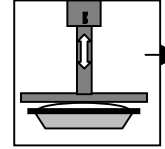
Until recently, the use of porous package materials has limited the available test methods to manual, operator controlled methods such as the dye penetration method (ASTM F-1929), vacuum bubble test (ASTM D-3078) and visual (ASTM F-1886). All these methods are non-quantitative and operator dependent, thus subject to some related uncertainty. Recently two leakage test methods for porous barrier trays have been proposed for ASTM method qualification. In both cases the methods are non-destructive and block the porous barrier to allow testing of the remaining package walls or seals. One method uses CO<sub>2</sub> as a trace gas for detection of leaks, and the other method uses a vacuum decay. Most methods for porous packages have been demonstrated to detect leak paths of 25-100um or equivalent diameter which translates to relatively large leakage rates (10<sup>1</sup> to 10<sup>-1</sup> sccs) when compared to other methods for non-porous package types.

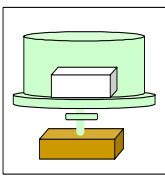
TABLE 1		MATERIALS APPROPRIATE	DESTRUCTIVE/ NON-DESTRUCTIVE	APPROXIMATE SENSITIVITY	RELATIVE COST
Bubble (“Dunk”) Testing		Porous, Non-Porous	Destructive	10 <sup>-2</sup> to 10 <sup>-3</sup> sccs with vacuum	\$100- \$1,000
Trace Gas Sensing		Non-porous	Non-destructive	10 <sup>-4</sup> to 10 <sup>-5</sup> sccs (helium)	\$3,000- \$10,000
Force Decay Testing		Non-Porous	Non-destructive	10 <sup>-1</sup> to 10 <sup>-3</sup> sccs	\$12,000- \$20,000
Pressure/ Vacuum Decay Testing		Non-Porous	Destructive or Non-Destructive	10 <sup>-4</sup> to 10 <sup>-6</sup> sccs	\$5,000- \$12,000
Mass Spectrometry		Non-Porous	Non-destructive	10 <sup>-9</sup> to 10 <sup>-11</sup> sccs (helium)	\$25,000- \$100,000

Non-porous material selection for medical packages provides a greater range of testing options. Certain manual/operator methods may not be appropriate, such as dye penetration or certain visual methods. However, non-porous packages lend themselves to many instrumented methods. These methods include trace gas sniffing, pressure/vacuum decay, force decay and helium mass spectrometry tests (see Table I). Methods that have current ASTM test methods developed are pressure decay (ASTM F2095), trace gas sniffing (ASTM E-2024), and vacuum bubble testing (ASTM D-3078).



Tests on non-porous packages can be either destructive or non-destructive in nature. However, caution must be exercised by the user to determine if the “non-destructive” method will cause damage to package seals with pressure differentials applied or gases exposed to the product. For example, pressure decay tests on foil laminate pouches with TM Electronics’ leak testers have found leaks at the  $10^{-4}$  sccs level with instrument resolutions at 0.0001 psi. When used with appropriate restraining fixtures these tests, while destructive to the package but not to the contained product, are relatively inexpensive, fast and repeatable. TM Electronics recommends that package leak tests be conducted after burst tests have been performed on the package with their BT-1000 Automated Package Tester and that the leak test pressure be kept below 30% of the burst seal strength. Thus, stresses on the seals will not affect the leak test. Tests which penetrate walls or immerse packages in fluids are generally considered destructive. While non-destructive tests are viewed as preferable for product/package recovery, the cost of those tests may be higher due to slower test cycles or higher equipment and operating costs.

Non-porous packages can be leak tested with a broad range of sensitivities. As discussed above, sensitivity selection can be based on a number of product/package requirements. Certainly maintenance of the sterile barrier is required; however, a quantified leakage rate for that property has not been defined. Maximum sensitivity is found using Mass Spectrometer helium detection. Although this test requires helium to be introduced into the package, it provides the lowest detection level. Requirements for long term moisture barrier properties may demand high sensitivity tests which mandate use of this method, while sterile barrier properties alone may require only modest sensitivities found in other, less costly methods. Table I indicates relative sensitivity levels of the several methods, as well as their relative costs.

Most instrumented methods provide quantitative results. While some methods are attribute Pass/Fail tests, a functional leakage reference can be applied for qualification. Other methods that provide quantitative variable data can be used for statistical quality or process control.

Progress in medical package testing has been made through the use of documented (ASTM) physical test methods. New methodologies need to be brought to the industry from other sciences such as the chemical or microbiological sciences to improve the manufacturers and end users’ confidence in the sterile quality of the package over its lifetime. Medical device packaging presents a formidable challenge to product manufacturers because of the large variety of material, sterilization and product functional issues. The packaging engineer is helped by using the ANSI/AAMI/ISO-11607 guideline to consider both seal strength and leakage integrity measurements for process control and final package quality. Engineering judgment must be exercised in applying the most effective as well as most economical test methods. At the end of the day, the medical device manufacturer is responsible to provide not only safe and effective medical devices but also safe and effective medical device packages.

### ***Bibliography and Reference List:***

AAMI TIR No. 22 – 1998. “Guidance for ANSI/AAMI/ISO 11607-1997, Packaging for terminally sterilized medical devices.” ©1998, Association for the Advancement of Medical Instrumentation, Arlington, VA 22201.

ANSI/AAMI/ISO 11607-1997, “Packaging for terminally sterilized medical devices.” 1997, International Organization for Standardization.

“ASTM F-88-00, Standard Test Method for Seal Strength Testing of Flexible Barrier Materials”, *1997 Annual Book of Standards*, vol 15.09, West Conshohocken, PA, American Society for Testing and Materials, 1997.

“ASTM F 1140-00, Standard Test Method for Failure Resistance of Unrestrained and Nonrigid Packages for Medical Applications,” *ibid*.

“ASTM F2054-00, Standard Test Method for Burst Testing of Flexible Package Seals Using Internal Air Pressurization Within Restraining Plates,” *ibid*.

“ASTM F2095-01, Standard Test Methods for Pressure Decay Leak Test for Nonporous Flexible Packages With and Without Restraining Plates,” *ibid*.

“ASTMF2096-01, Standard Test Method for Detecting Gross Leaks in Porous Medical Packaging by Internal Pressurization (Bubble Test),” *ibid*.

FDA, “Recognition and Use of Consensus Standards; Final Guidance for Industry and FDA Staff”, Issued June 20, 2001; see [www.fda.gov/cdrh/ost/321.html](http://www.fda.gov/cdrh/ost/321.html).

Franks, Stephen H. and Donald S. Barcan. “Examining the Relationship of Tensile and Inflation Seal Strength Tests in Medical Pouches”. ©1999, Donbar Industries, Inc. & TM Electronics, Inc.

Franks, Stephen. “Calculating Factors of Safety for Package Burst and Creep Test Fixtures”. *Medical Device & Diagnostic Industry*, June 1998.

Franks, Stephen. “Leak, Flow and Package Testing 101”. ©2000, TM Electronics, Inc.

Hansen, Joyce et al. “In Quest of Sterile Packaging, Part 1: Approaches to Package Testing”. *Medical Device & Diagnostic Industry*, 17(8):56-61, 1995.

Jones, Lois et al. “In Quest of Sterile Packaging: Part 2: Physical Package Integrity Test Methods”. *Medical Device & Diagnostic Industry*, 17(9):81-85, 1995.

McMaster, Robert C. (ed), *Non-Destructive Testing Handbook, Second Edition*. Volume 1, Leak Testing. American Society for Nondestructive Testing, Inc., 1982.