

HORIZONTAL LIFELINE SYSTEMS

PLEASE BE ADVISED

WE ENCOURAGE THAT
YOU CONTACT OUR OFFICE
FOR THE MOST CURRENT
CHANGES TO THIS
SECTION

TABLE OF CONTENTS

Thaler Or Equal	K-0
EASY SLIDER™ Horizontal Lifeline PRIMER	K-1
K-700 EASY SLIDER™ Horizontal Lifeline Fall Protection System (Roof Application)	K-2
K-701 EASY SLIDER™ Horizontal Lifeline Fall Protection System (Wall Application)	K-3
K-702 EASY SLIDER™ Horizontal Lifeline Fall Protection System (Overhead Application)	K-4
K-703 EASY SLIDER™ Horizontal Lifeline Fall Protection System (Single Span Application)	K-5
EASY SLIDEER™ Horizontal Lifelines Fall Protection Systems Components	K-6
Horizontal Lifeline Fall Protection System Specification	K-7

WHAT IT TAKES TO BE THALER OR EQUAL

When specifications read Thaler or Equal, it is the responsibility of specifiers and building owners to determine what it means to be “Or Equal”. The following data has been presented to quickly help assess the comparative merits of “competitive” products. Thaler Horizontal Lifeline products have a number of Value Added features that should be considered when trying to equate the “Or Equal”.

CHECK THE COMPETITION	THALER VALUE ADDED FEATURES
<input type="checkbox"/>	<input checked="" type="checkbox"/> Provides unique fall protection; new in-line Thaler Energy Absorber (TEA) assists in reducing or dissipating fall arrest forces should users experience a fall, thereby lessening Maximum Arrest Force (MAF) the shortduration, dynamic peak force acting for 5 to 10 milliseconds on a falling body during fall arrest.
<input type="checkbox"/>	<input checked="" type="checkbox"/> Protects up to 4 workers simultaneously; depending on anchor spacing, and number of shuttle runners provided, Thaler “EASY SLIDER” is designed to protect up to 4 workers from falling, on same system.
<input type="checkbox"/>	<input checked="" type="checkbox"/> Superior cable composition; 3/8” (10 mm) diameter Type 304 stainless steel, 7 x 19 structure provides unlimited line strength, added strength, and extra margin of safety.
<input type="checkbox"/>	<input checked="" type="checkbox"/> Added anchor strength; all anchor posts are designed to resist without fracture a pullout force of 5400 lbs (24.02 kN), applied in the most adverse direction.
<input type="checkbox"/>	<input checked="" type="checkbox"/> Specify any angle for corners; in addition to common corner angles such as 45°, 90°, 135°, any angle in 1° increments may be specified without additional cost.
<input type="checkbox"/>	<input checked="" type="checkbox"/> Cost advantage to building owner; most Thaler “EASY SLIDER” system components are fabricated in-house thereby eliminating middle-man suppliers which can result in significant savings. “EASY SLIDER” is one of the most cost-efficient horizontal lifeline systems on the market. Be sure to obtain accurate cost data before making specifying decision.
<input type="checkbox"/>	<input checked="" type="checkbox"/> “EASY SLIDER” means hands free movement; users travel full length of horizontal lifeline without disconnecting while having both hands free.
<input type="checkbox"/>	<input checked="" type="checkbox"/> Aesthetically pleasing flashing; pre-formed Thaler STACK JACK flashing used with roof anchor posts are arguably the best , most reliable, maintenance-free flashing product on the market today. The STACK JACK relies on memory in the EPDM seals to prevent leaks from above and condensation from below (air barrier design). See Thaler STACK JACK flashing literature (Section A of manual), or Thaler EPDM Flashing Seals literature.
<input type="checkbox"/>	<input checked="" type="checkbox"/> Long distance between supports; a single line horizontal lifeline system such as the Thaler K-703 “EASY SLIDER” reduces the number of roof penetrations by providing up to 80’-0” (24.4 m) distance between supports using a double TEA (Thaler Energy Absorber) in the horizontal cable, or 60’-0” (18.3 m) distance using single TEA.
<input type="checkbox"/>	<input checked="" type="checkbox"/> Maintenance-Free; except for occasional wiping of any dirt that has accumulated on the stainless steel horizontal cable, and annual inspection (by others), the “EASY SLIDER” requires no maintenance. In addition the STACK JACK flashing used for the anchor posts is simply and cleanly installed without messy vaulking seals.
<input type="checkbox"/>	<input checked="" type="checkbox"/> 20 year Warranty; guaranteed against leaks and defects in materials and/or manufacture when installed in accordance with Thaler "Installation Instructions".
<input type="checkbox"/>	<input checked="" type="checkbox"/> Written "Installation Instructions"; provided with every Thaler product.



THALER 05_11_24_23 MAINTENANCE EQUIPMENT
horizontal lifeline systems
2005

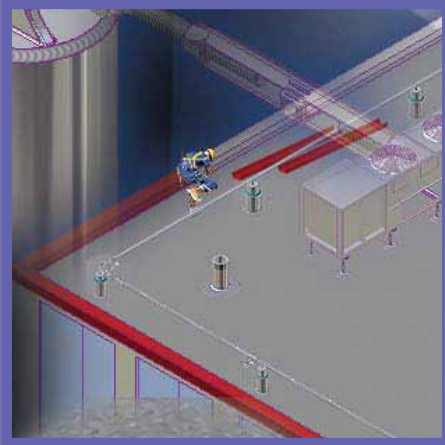

Thaler Energy Absorber (TEA)

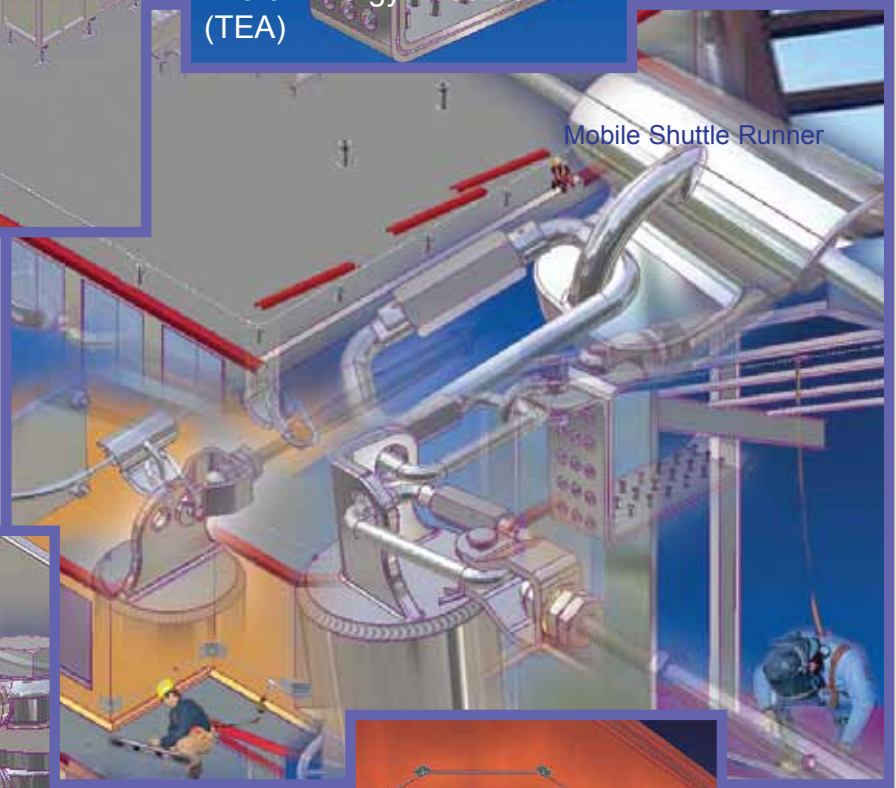

Mobile Shuttle Runner

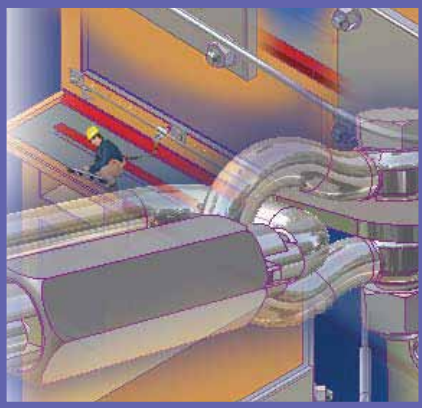

EASY SLIDER™ HORIZONTAL LIFELINE PRIMER

A Pre-Engineered, Hands Free Fall Protection System For Roof,
Wall & Overhead Applications

INTRODUCTION

A fall from elevation (the uncontrolled drop from one level to another) is similar to winning the lottery. You never know when it is going to happen.

The quality management concept that 99.9% reliability is not good enough should be the watchword for building designers or owners when it comes to fall protection.

Fall protection can be profitable. At present, the losses in injury/fatality costs and suffering are staggering. The cost of fall protection currently is incurred at the legal and compensation end of the economic cycle, rather than at the planning or equipment use stage. Plaintiff lawyers know that the violation of OSHA, CSA or department of labor standards or rules, and the general lack of common sense when it comes to fall hazards, is rampant in almost every industry in North America.

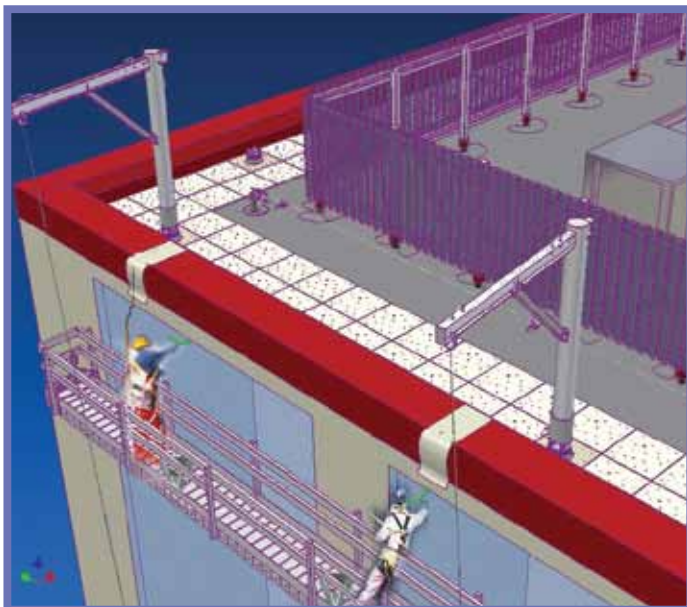

Single Span horizontal lifeline used to access and provide fall protection for window cleaning operations.

Window cleaners, rooftop equipment maintenance personnel, roof inspectors, and other workers performing tasks at rooftop level without benefit or guardrails or guardrail height parapets are particularly vulnerable to falls from height. Elevated fall hazards are a risk architects, engineers, general contractors, and building owners shouldn't be taking.....or imposing on others.

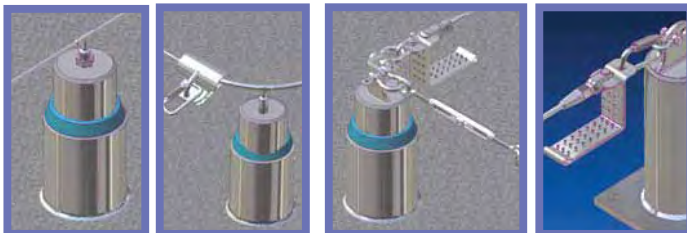

Finished installation shows aesthetic qualities of Thaler anchor and flashing products.

THE CONCEPT OF FALL PROTECTION

Can anyone know if a serious or fatal fall will occur in the first few seconds of a worker's career or 30 years later in the last few seconds? Professionally, any safety approach must assume the first few seconds, and building owners or their agents must immediately act to control a fall hazard, which is likely to result in serious or fatal injury if the fall occurs.

Fall protection is the back-up system planned for a worker who could potentially lose his or her balance at height. It is a planned response used to control or eliminate injury potential where foreseeable fall hazards are present.

Fall protection can minimally be applied by the use of personnel fall protection equipment with pre-designated anchorage points, and a cable-type horizontal lifeline, mounted on roof, wall or overhead surfaces, to provide safe mobility at elevation, including travel to and from workstations e.g. window cleaning, mechanical equipment, roof edge, around skylights (interior falls), narrow roof areas and similar locations.

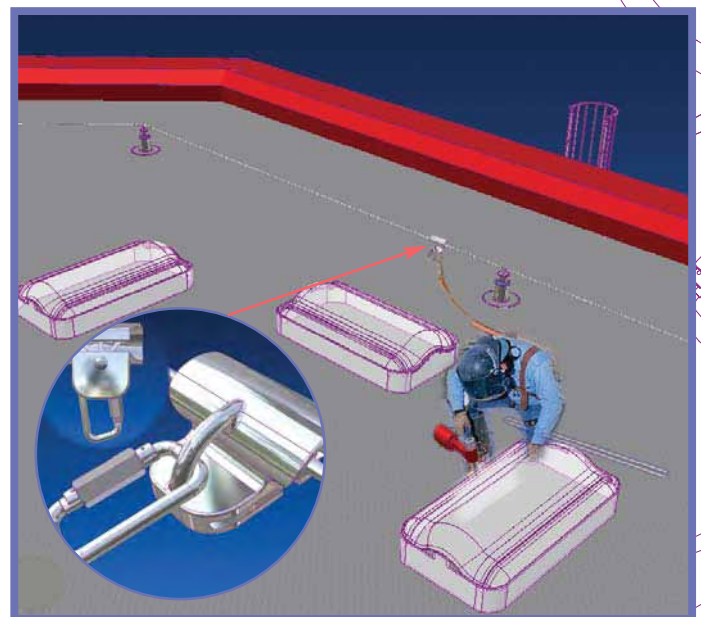

Safety organizations recommend using fall protection around skylight areas if not protected by guardrails or screen covers (interior fall hazard).

Protection is required to keep workers from striking objects over a certain fall distance and to avoid pendulum swing, crushing and foreseeable impact with any part of the body to which injury could occur.

The objective of elevated fall protection is to convert the hazard to a slip or minor fall at the very worst - a fall from which, hopefully, no injury occurs.

HORIZONTAL LIFELINES

The EASY SLIDER horizontal lifeline designs offered by Thaler Metal Industries consists of a stainless steel cable installed horizontally and used for the attachment of a worker's lanyard or lifeline device (self-retracting lifeline or synthetic lifeline with rope grab) while moving horizontally. It is used to control dangerous pendulum-like swing falls by limiting free fall distance.

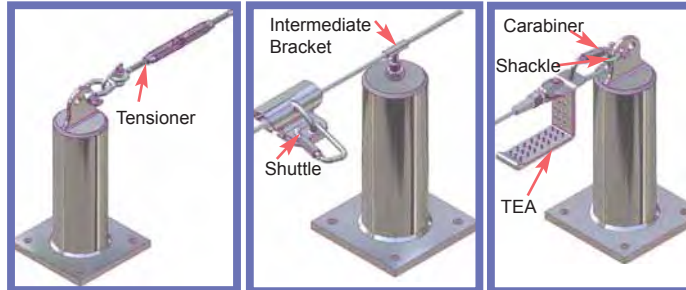

Terminal Anchor With Tensioner Intermediate Anchor Terminal End Anchor With Thaler Energy Absorber (TEA)

BASIC EASY SLIDER ROOF MOUNTED COMPONENTS

The cable is mounted to fixed anchorages secured to roof, wall or other structural elements of the building. These anchor points are capable of supporting at least twice the maximum potential force for each fall protection system that may be used.

A full body harness (not belt) supplied by others, is to be used with Thaler EASY SLIDER designs. The harness consists of an arrangement of straps designed to distribute arresting and suspension forces over the buttocks, pelvis, thighs, chest and shoulders.



BASIC EASY SLIDER WALL MOUNTED COMPONENTS

Thaler EASY SLIDER Horizontal Lifeline, designed for restraint and strong enough for fall protection, is a "hands-free" fall protection system that allows users to walk uninterrupted the entire length of the system without having to unhook to pass through intermediate or corner support points. The number of users (up to four per system) is dependent on anchor spacing. Note: double lanyard systems have proven cumbersome and do not always provide continuous protection due to worker misuse.

EASY-SLIDER is made up of end anchorages, intermediate anchorages, mobile shuttle runners (one per worker) stainless steel horizontal cable, and inline fittings such as Thaler Energy Absorber, tensioner, corner brackets, swages and other components.

However, the heart of the EASY-SLIDER systems are embodied in the mobile shuttle runner and Thaler Energy Absorber. Here's how they work.

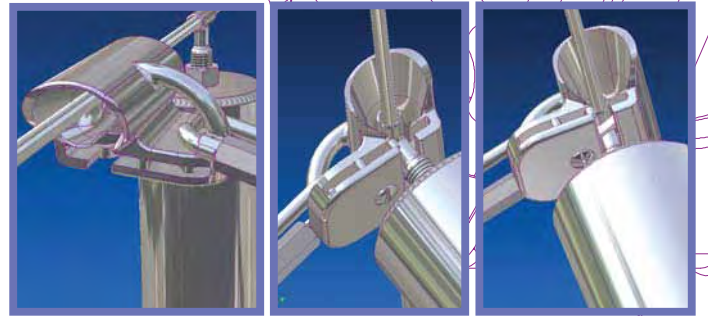

EASY-SLIDER shuttle runner position on cable. Shuttle runner entering the intermediate bracket Shuttle runner moves between and through spur wheel and upper part of bracket.

MOBILE SHUTTLE RUNNER



In-House Testing Assembly Connection Detail Between Anchor and Thaler Energy Absorber

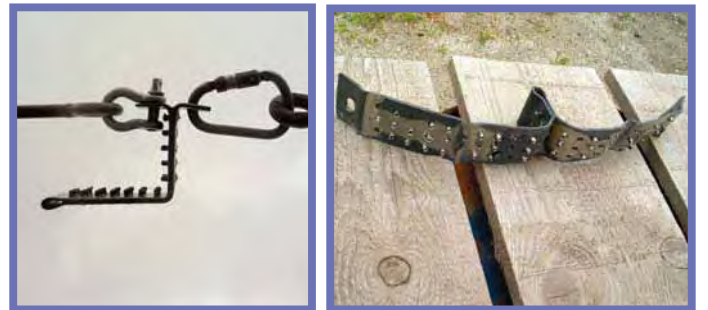

Thaler Energy Absorber (TEA) Before Load Test. Thaler Energy Absorber (TEA) After Load Test

Force in the horizontal lifeline is absorbed by dissipation of energy due to plastic deformation (or rupture and cracking) of stainless steel rivets and stainless steel L shaped bracket.

HOW THE THALER ENERGY ABSORBER (TEA) WORKS



BASIC OVERHEAD MOUNTED COMPONENTS

CONFORMANCES

The Thaler EASY SLIDER Horizontal Lifeline System conforms to: *Canadian*

1. National Standards of Canada

- A. CAN/CSA-Z91-02 (Health and Safety Code for Suspended Equipment Operations).
- B. CAN/CSA- Z259.13-04 (Flexible Horizontal Lifeline Systems).
- C. CAN/CSA-Z271-98 (Safety Code for Suspended Elevating Platforms).
- D. CAN/CSA-Z259.10-M90 (Full Body Harness).
- E. CAN/CSA-Z259.1-95 (Safety Belts and Lanyards).

2. Canadian Standards Association

- A. CSA G40.21-M1987, M350W and M300W (Structural Quality Steels).
- B. CSA W47.1-1983 (Certification of Companies for Fusion Welding of Steel Structures).
- C. CSA W59-M1989 (Welded Steel Construction - Metal ARC Welding).
- D. CSA G164-M1981 (Hot Dip Galvanizing of Irregularly Shaped Articles).

3. Ontario Ministry of Labour

- A. Ontario Regulation 527/88 and 714/82 (Regulation for Window Cleaning).

4. Ontario New Home Warranty Program

- A. ONHWP Condominium Construction Guide (Chapter 12-Roof Anchors).

5. Canadian General Standards Board

- A. CGSB-51-GP 46MP (Manual for Installers of Spray Urethane Foam Thermal Insulation).

6. Canadian Urethane Foam Contractor's Association

- A. CUFCA Manual for Installers of Spray Polyurethane Foam Thermal Insulation.

United States

7. Occupational Safety & Health Administration (U.S. Department of Labor)

- A. OSHA 1910.28 SubPart D (Walking-Working Surfaces)
- B. OSHA 1910.66, SubPart F (Powered Platforms, Manlifts, and Vehicle-Mounted Work Platforms).
- C. OSHA 1926.502, SubPart M (Fall Protection Systems Criteria and Practices)
- D. CAL OSHA, Title 8, Section 3291(f), Article 5. Window Cleaning (General Industry Safety Order, California Code of Regulations)
- E. Department of Labor Memorandum to Regional Administrators for Descent Control Devices.

8. American National Standards Institute

- A. ANSI A39.1-1969 (Safety Requirements for Window Cleaning).
- B. ANSI Z359.1-1992 (Safety Requirements for Personal Fall Arrest Systems, Subsystems and Components).
- C. ANSI A10.14-1991(Requirements for Safety Belts, Harnesses, Lanyards and Lifelines for Construction and Industrial Use).

9. American Society of Mechanical Engineers

- A. ASME A120.1-1996 (Safety Requirements for Powered Platforms for Building Maintenance).
- B. ASME Addenda A120.1a-1997 and A120.1b-1999.

10. International Window Cleaner's Association

- A. IWCA I-14.1-2001 (Window Cleaning Safety Standard), An American National Standard.

11. American Society for Testing and Materials

- A. ASTM D3963/D M-87 (Structural Specification for Epoxy Reinforcing Steel).
- B. ASTM A36 (Non exposed Structural Components).
- C. ASTM A123 (Standard Specification for Zinc Coating-Hot Dip Galvanizing of Iron and Steel Products).
- D. ASTM Z325 (Bolts, Nuts and Washers).

12. American Welding Society

- A. AWS D1.1 (Structural Welding Code).

13. Aluminum Association

- A. AA 5AS-30 (Specifications for Aluminum Structures).

FALL PROTECTION TERMINOLOGY

A few definitions construction professionals and building owners should be acquainted with include:

Fall Arrest System: A tested device and components that function together as a system to arrest a free fall and minimize the potential for compounding injury.

Personal Fall Protection System: A system used to arrest an employee in a fall from working level. It consists of an anchorage, connectors, a body harness, and may include a lanyard, deceleration device, lifeline, or suitable combinations of these.

Free Fall: The act of falling before the personal fall arrest system begins to apply force to arrest the fall.

Free Fall Distance: The vertical displacement of the fall arrest attachment point on the employee's body harness between onset of the fall and just before the system begins to apply force to arrest the fall. This distance excludes deceleration distance, and lifeline and lanyard elongation, but includes any deceleration device slide distance or self-retracting lifeline/lanyard extension before their operation and before full arrest forces occur. The vertical component of a swing fall should not exceed 6'-0" (1.8 m) or the maximum free fall distance permitted by the authority having jurisdiction e.g. 1.5 meters in Ontario.



Illustration shows workers on narrow roof secured to wall-type horizontal lifeline.

Maximum Arrest Force (MAF): The peak force measured by the test instrumentation during arrest of the test weight in the dynamic tests set forth in a standard such as ANSI Z359.1-1992.

Thaler Note: Maximum Arrest Force (MAF) is the short-duration, dynamic peak force acting 5 to 10 milliseconds on a falling body during arrest of its fall. The value of the MAF is regulated; in Canada and the United States it must not exceed 8kN (1800 lbs). That legal limit has its origins in medical and biomechanical research on human volunteers (research restricted to levels below MAF) and animals (dogs and monkeys). Researchers concluded that the short-duration force acting vertically upward along the human spine is unlikely to cause an injury if it is below 9kN (2000 lbs): The MAF limit of 8 kN (1800 lbs) represents an injury threshold for the upward force applied via the sub-pelvic strap; therefore, if the user is using a safety belt, less than half the current MAF limit may result in injury. A healthy individual in a full body harness with D-ring (mandatory equipment) between the shoulder blades should survive an MAF of 8kN (1800 lbs) without any serious injury.

CABLE HEIGHT, TENSION AND CLEARANCES

Horizontal lifeline height should be such that lanyards or other connection devices are easily attached without interfering with the movement of the user.

The sag in the horizontal cable between any two supports of the lifeline system should be limited to 12" (305 mm). This criteria (installation tension) is related to a fall situation when a fall occurs and the line is loaded with MAF (Maximum Arrest Force).

The minimum clearance required below the level of the horizontal lifeline to the nearest obstruction is outlined in the following chart.

INITIAL SAG REQUIREMENT, 450 lbs (204 kg), 2 men falling 6'-0" (1.8 m)

SPAN	MIN. SAG	RECOMMENDED SAG
10' (3.048 m)	0.25" (6 mm)	2.25" (57 mm)
20' (6.096 m)	1.25" (32 mm)	3" (76 mm)
30' (9.144 m)	2" (51 mm)	3.75" (95 mm)
40' (12.192 m)	2.75" (70 mm)	4.50" (114 mm)
50' (15.24 m)	3.5" (89 mm)	5.25" (133 mm)
60' (18.288 m)	4" (102 mm)	6" (152 mm)
70' (21.366 m)	4.75" (121 mm)	6.75" (171 mm)
80' (24.384 m)	5.5" (140 mm)	7.50" (191 mm)
90' (17.432 m)	6.25" (159 mm)	8.25" (210 mm)
100' (30.48 m)	7" (178 mm)	9" (228 mm)
110' (33.528 m)	7.75" (197 mm)	9.75" (2487 mm)
120' (36.576 m)	8.5" (216 mm)	10.5" (267 mm)

CLEARANCE REQUIREMENT, 450 lbs (204 kg), 2 men falling 6'-0" (1.8 m)

SPAN	MIN. CLEARANCE WITH 6'-0" (1.8 m) LANYARD	MIN. CLEARANCE WITH SELF RETRACTING LANYARD
10' (3.048 m)	17.92' (5.5 m)	6.92' (2.1 m)
20' (6.096 m)	19.16' (5.8 m)	8' (2.44 m)
30' (9.144 m)	20.5' (6.25 m)	9.08' (2.77 m)
40' (12.192 m)	21.83' (6.65 m)	10.16' (3.10 m)
50' (15.24 m)	23.08' (7.03 m)	11.33' (3.45 m)
60' (18.288 m)	24.42' (7.44 m)	12.42' (3.78 m)
70' (21.366 m)	25.66' (7.82 m)	13.5' (4.12 m)
80' (24.384 m)	27' (8.23 m)	14.58' (4.44 m)
90' (17.432 m)	28.33' (8.63 m)	15.66' (4.77 m)
100' (30.48 m)	29.58' (9.02 m)	16.83' (5.13 m)

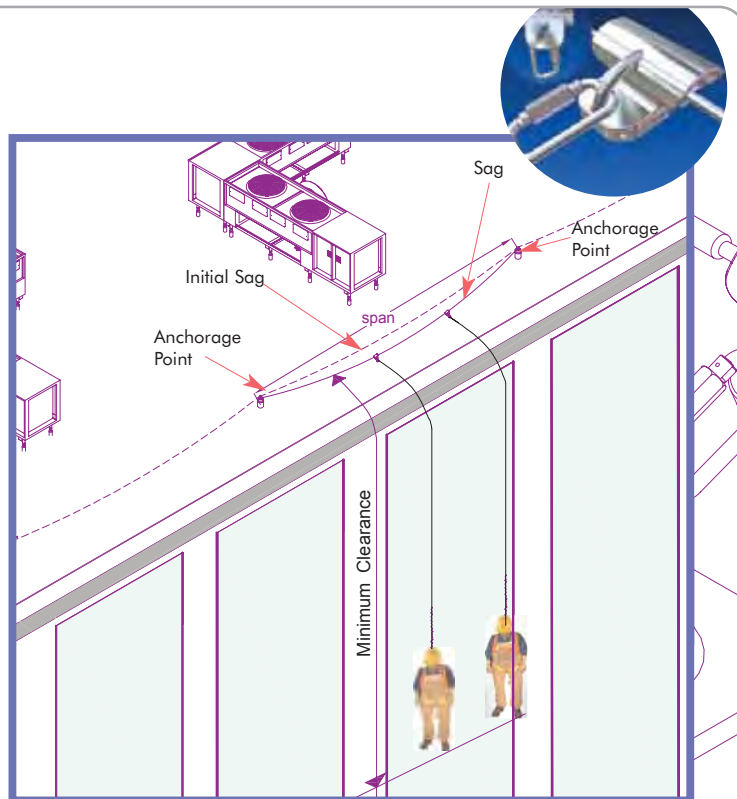

KEY LINE DIAGRAM ILLUSTRATING CLEARANCE REQUIREMENT IN A FALL ARREST SITUATION

PLANNING ASSISTANCE

Without obligation, Thaler Metal Industries Ltd. will provide layout drawings for EASY SLIDER systems in compliance with all applicable standards, safety regulations and local building codes.

Simply forward the following Autocad drawings via e-mail courier, or mail:

- Architectural roof plan
- Structural roof plan
- Building elevation drawings
- Building section drawings with special emphasis on parapet or roof edge details
- System access openings e.g. hatches, operable windows, roof ladders or stairs, and similar access points

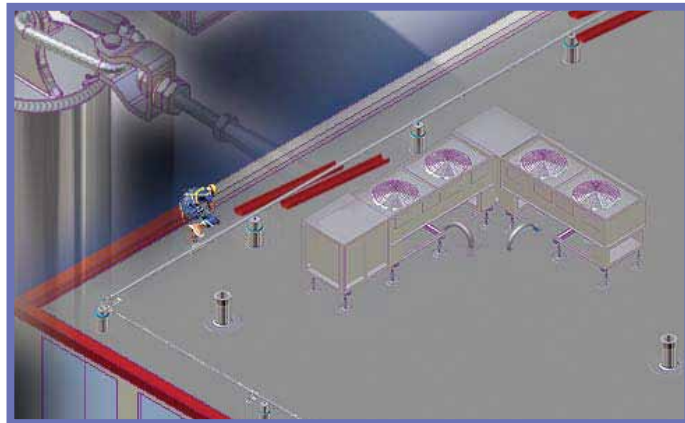

Working around mechanical equipment close to roof edges is a common fall hazard area.

RELATED DATA

Refer to the following specific product data or other Thaler literature for Thaler EASY SLIDER Horizontal Lifeline fall protection systems (Section K of Thaler Manual).

- K-700 (Roof Application)
- K-701 (Wall Application)
- K-702 (Overhead Application)
- K-703 (Single Span Application)
- Specification (Section of Work, 3-Part Format)
- Components
- What It Takes To Be "Thaler Or Equal"
- STACK JACK Flashings (Section A of Manual)
- EPDM Flashing Seals (Section A of Manual)
- Horizontal Lifeline For Metal roofs (Section D of Manual)
- Fall Arrest Roof Anchors (Section I of Manual)

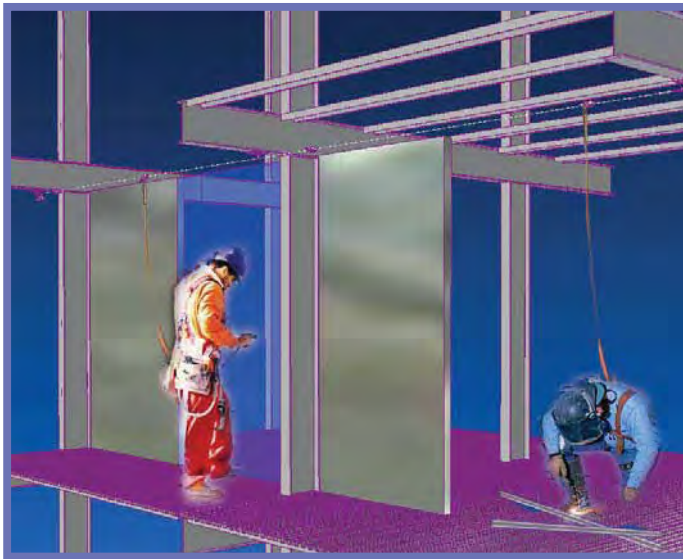

Thaler EASY SLIDER Horizontal Lifeline (overhead application) for Construction use.



Thaler EASY-SLIDER Horizontal Lifeline for Metal Roofs (see Section D of Manual)

Canada 1-800-387-7217 U.S. 1-800-576-1200 Internet: www.thalermetal.com e-mail: info@thalermetal.com

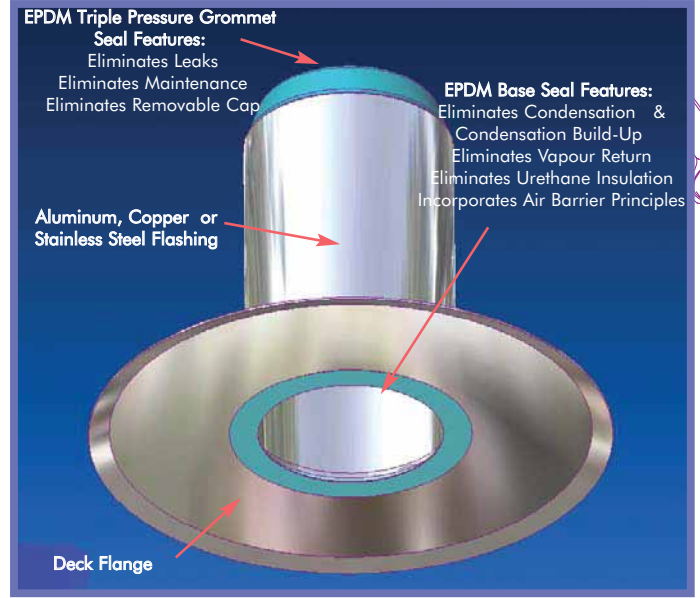

Thaler STACK JACK Flashing meets the requirements for air leakage control better than any protrusion flashing on the market to-day (better looking too).



Thaler EASY SLIDER Horizontal Lifeline for Metal Roof employing Thaler EPDM Flexible Flashing

1902 Common St. Suite 500
New Braunfels, TX, 78130 USA
tell: 830-626-6001
fax: 830-626-6010
866-583-6001

2611 Drew Road, Mississauga,
ON, L4T 1G1, CANADA
tell: 905-677-1520
fax: 905-677-1503
800-387-7217



Metal USA Inc.



Metal Industries Ltd.

ROOF SPECIALTIES K-700 EASY SLIDERTM HORIZONTAL LIFELINE FALL PROTECTION SYSTEM (Roof Application)



Maintenance Personnel Working Around Parapet Edge of building, A Recognized Fall Hazard Area

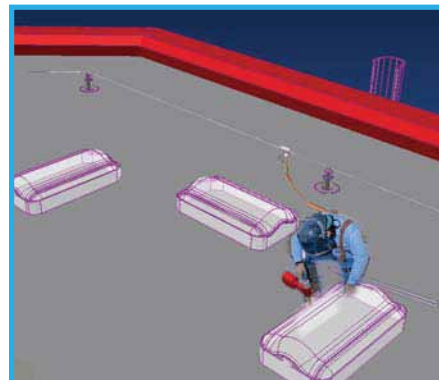

Tied Off While Working Around Skylights, A Potentially Dangerous Area.

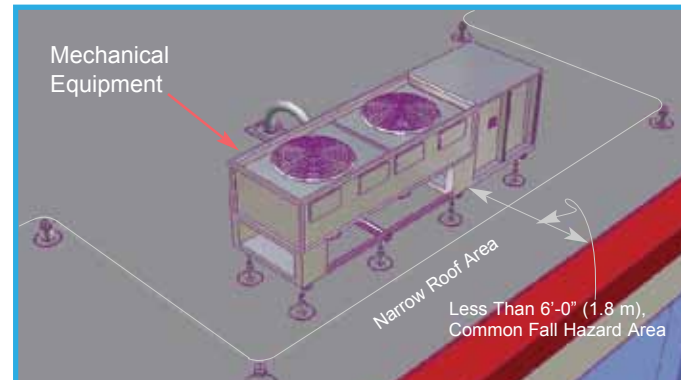

Close Up View of EASY SLIDER Horizontal Lifeline For Servicing Mechanical Equipment Close to Roof Edge



Close-Up View of Mobile Shuttle Runner. Inset shows Underside of Shuttle

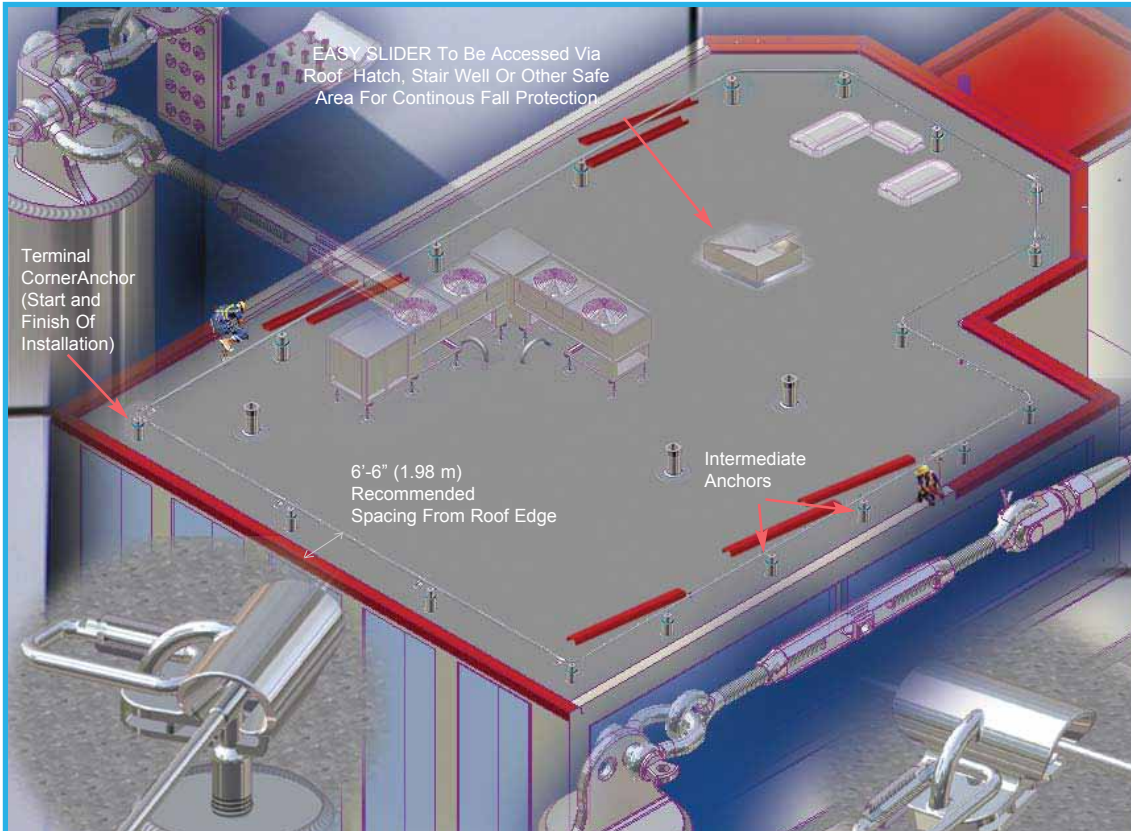

EASY SLIDER Horizontal Lifeline Installed Around Perimeter Of Roof With Low Parapet (less than guardrail height)

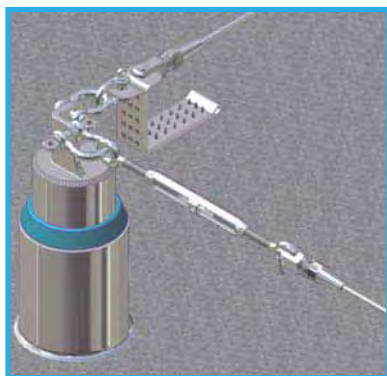

Terminal Corner Anchor with Tensioner and Thaler Energy Absorber (TEA)

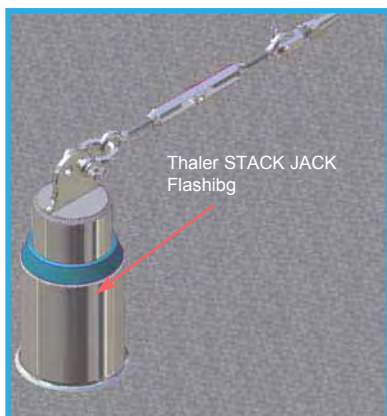

Terminal Anchor With Tensioner

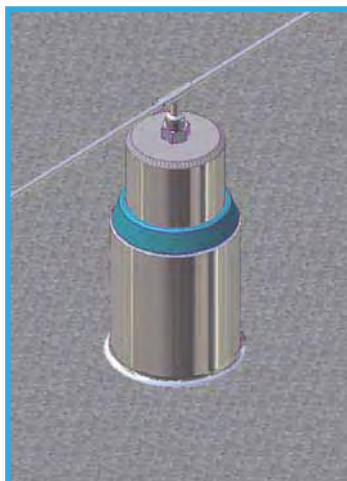

Intermediate Anchor With Bracket



Terminal Anchor With Thaler Energy Absorber (TEA)



Corner Anchor With Any-Angle Bracket

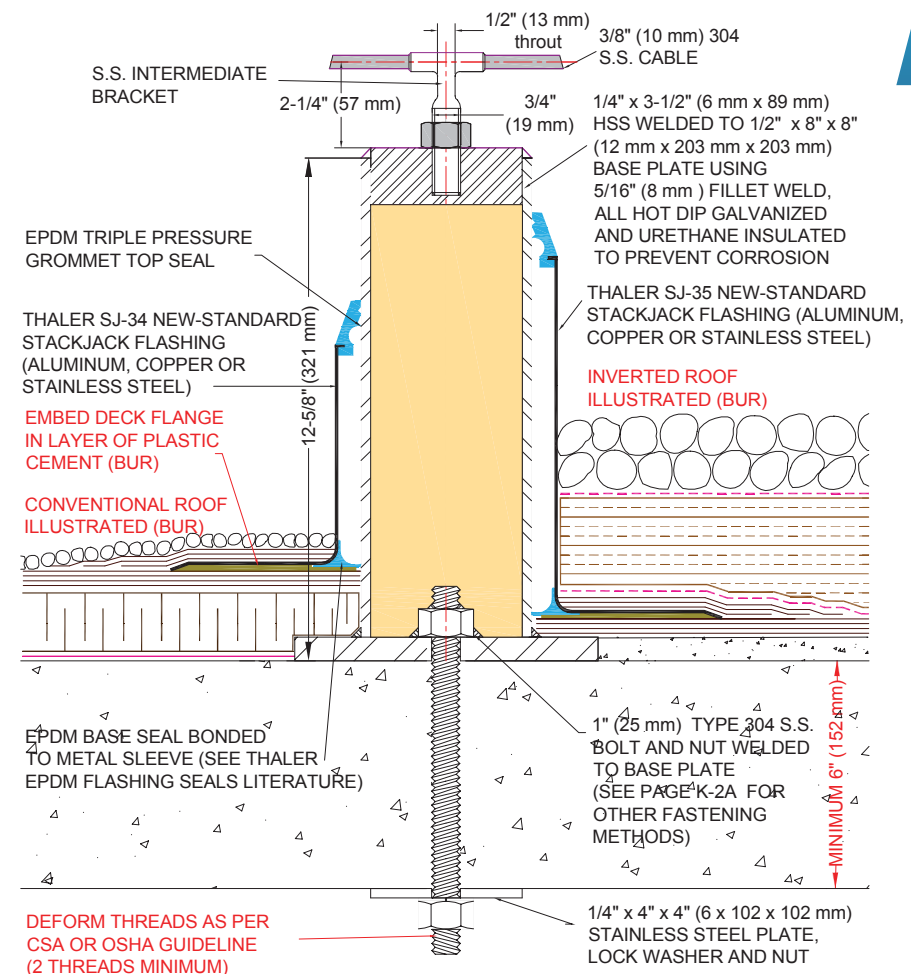

INTERMEDIATE HORIZONTAL LIFELINE ANCHOR (K-FARA-1-706) PATENT PENDING

the K-700 EASY SLIDER stainless steel cable only requires occasional wiping with a damp cloth to ensure free and easy movement of the shuttle component. In the event of a fall, the system including any affected harness, must be re-approved by a professional engineer before being placed back in service.

PLANNING SERVICE:

Thaler will provide layout drawings for the K-700 EASY SLIDER in compliance with all standards, safety regulations and local building codes.

SPECIFICATION (Short Form):

Horizontal lifeline system: Thaler K-700 EASY SLIDER Horizontal Lifeline fall protection system to [CSA-Z91-02][OSHA 1910.66, Subparts D and F] with: 3-1/2" (89 mm) dia. urethane insulated HSS anchor posts, wall thickness 1/4" (6 mm), hot dipped galvanized ASTM 500, 12" (305 mm) high, welded and bolted to 1/2" x 8" x 8" (12 mm x 203 mm x 203 mm) 44W base plate, securement to suit substrate; Type 316 stainless steel fittings (swaged end, energy absorber, double locking carabiner, shuttles end tensioner, intermediate brackets, corner pieces); Type 304 s.s. cable, 3/8" (10 mm) dia. 7 x 19 structure; [2][4] full body harnesses with integral shock absorber by others; [SJ-34, 7" (178 mm) high] [SJ-35 13" (330 mm) high] New-Standard STACK JACK Flashing of [.064" (1.6 mm) mill finish 1100-OT alloy aluminum] [.032" (0.831 mm) 24 oz. copper] [.031" (0.79 mm) 22 ga. Type 304 stainless steel] to CSA B272-93, with EPDM Triple Pressure Grommet Top Seal and EPDM Base Seal and [bituminous painted deck flange] [PVC coated deck flange]; manufactured by Thaler Metal Industries, 1-800-387-7217 (Mississauga, Ontario, Canada) or 1-800-576-1200 (New Braunfels, TX), installed as per manufacturer's written instructions. Provide 20 year warranty against leaks, condensation and defects in materials and/or manufacture.

INSTALLATION:

"Installation Instructions" are provided with every Thaler product. However, only Thaler or Thaler approved installers may install the the system which must be certified by a professional engineer prior to initial use. Essentially, the K-700 EASY SLIDER Horizontal Lifeline is installed by fastening the anchor posts to the roof structural substrate, installing flashing, and cable, including fittings.

Recommended Layout: Maximum spacing between anchor posts is 30'-0" (9.15 m) for system with one energy absorber, and 30'-0" to 60'-0" (9.15 to 12.3 m) for system with two energy absorbers. Entry and exit points should be located in a safe area to ensure continuous protection. Horizontal lifeline should not be located closer than 6'-6" (1.98 m) from any roof edge. For minimum clearance required below the level of the horizontal lifeline, see page K-1. Consult with Thaler for layout recommendations.

Ordering and Availability: Available throughout North America. Contact Thaler for list of distributors and current cost information. Products are typically available from stock.

DESCRIPTION:

The Thaler K-700 EASY SLIDER Horizontal Lifeline Fall Protection System is a complete pre-engineered multi-span flexible lifeline system consisting of end anchors, intermediate anchors, stainless steel cable, mobile attachment devices (shuttle runners), in-line fittings (tensioner, energy absorber, corner fittings, etc.) and up to 4 shuttles as standard. Full body harnesses with 6'-0" (1.8 m) long shock absorbing lanyards (by others) completes the assembly. End and intermediate anchors consist of urethane insulated hollow steel posts (HSS) equipped with different type heads to accommodate the cable, and time-tested Thaler STACK JACK Flashing. Anchor are also available with different type bases for fastening to a variety of roof structures. All anchor posts are designed to resist without fracture a pull-out force of 5400 lbs (24.02 kN), applied in the most adverse direction.

PROMINENT FEATURES:

Designed to protect up to 2 workers against falls from height for systems in length up to 200'-0" (61 m) and 4 workers for the systems more than 200'-0" (61 m) as standard (prevents users from falling more than 6'-0" or 1.8 m). Hands free system allows users to walk uninterrupted the entire length of system. Thaler Energy Absorber (TEA), separate from harness shock absorber, assists in dissipating or reducing fall arrest forces. EASY SLIDER shuttle permits worker to connect or disconnect at any position on cable. Line length is unlimited. Condensation free and maintenance free (attractive, neat flashing never needs caulking. See Thaler EPDM Flashing Seals literature). Anchor integrity is backed by high \$7,000,000.00 liability insurance.

OPTIONS:

Any-angle corner units available as standard. Any type securement to suit structural substrate (cast-in-place, bolted, welded, etc.). PVC coated flashing deck flange for PVC roof membrane, bituminous painted flashing deck flange for BUR and ModBit roof membrane. Flashing is available aluminum, copper or stainless steel.

RECOMMENDED USE:

Suitable for both travel restraint and fall arrest using full body harness and lanyard, self retracting lifeline or lifeline with rope grab. Provides fall protection for servicing rooftop equipment, roof inspection, accessing window cleaning stations and similar applications on low slope/flat roofs. Designed to protect up to four workers (as standard) on system. See K-701 and K-702 systems for low or overhead applications.

APPLICABLE STANDARDS:

Thaler K-700 EASY SLIDER conforms to all Canadian and U.S. standards, provincial and state labor/safety codes and materials standards relating to anchor fabrication and horizontal lifeline applications. Conformance includes CSA, OML, ASME, ANSI, IWCA, OSHA, CAL OSHA, AISC, AWS, and other references. See Thaler EASY SLIDER Horizontal Lifeline Primer literature for introductory data on subject of fall protection.

WARRANTY:

20 year warranty (lifetime on all stainless steel) against leaks, condensation and defects in materials and/or manufacture when installed in accordance with Thaler "Installation Instructions".

MAINTENANCE:

Regulatory authorities require the horizontal lifeline system be inspected annually with inspection data (date, inspector's name and comments) recorded in the Fall Protection Maintenance Log book. Apart from this requirement, (continued on left)

Note: All Anchors are designed to resist without fracture a pull-out force of 5400 lbs (24.02 kN), applied in the most adverse direction

Note: Anchor to roof slab fastening shows adhesive bolt securement (for retrofit applications)

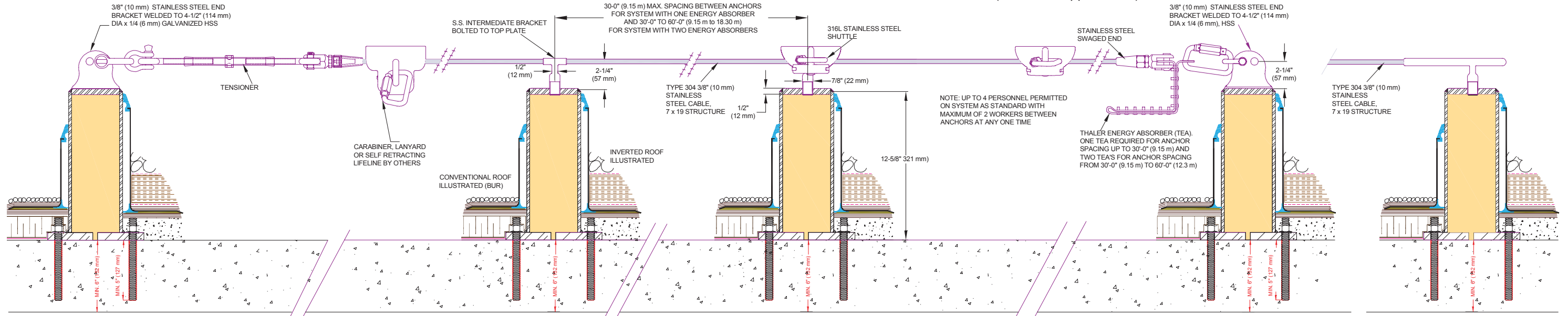

END ANCHOR WITH TENSIONER

INTERMEDIATE ANCHOR

INTERMEDIATE ANCHOR

END ANCHOR WITH ENERGY ABSORBER

CORNER ANCHOR

FASTENING METHODS FOR DIFFERENT STRUCTURES

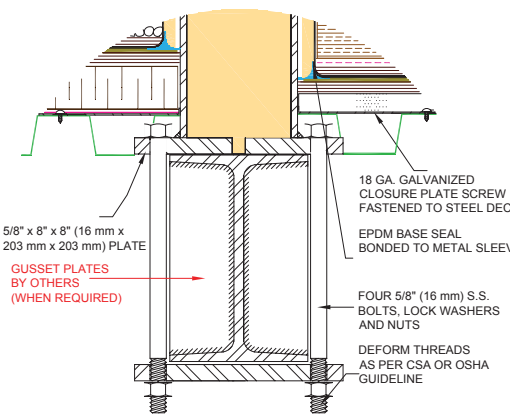
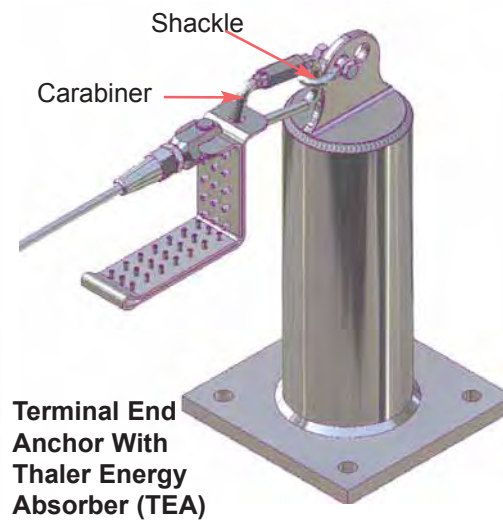
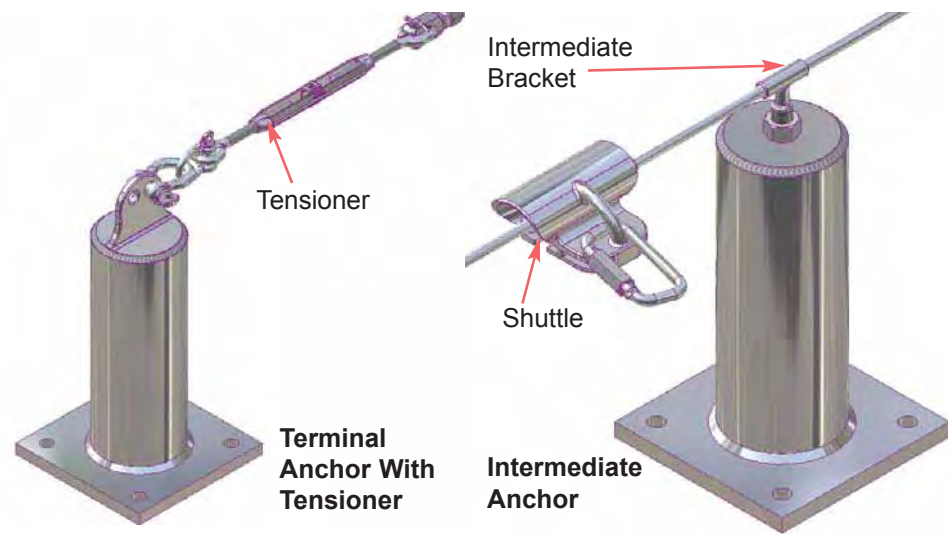

Bolt Around Beam (K-FARA-3-700)

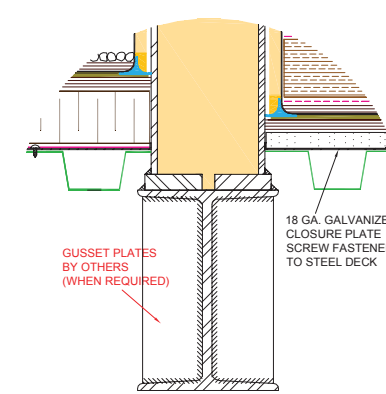

Welded (K-FARA-4-700)

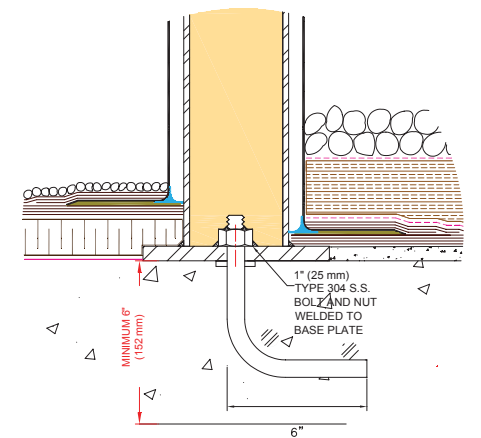

Cast-In-Place (K-FARA-5-701)

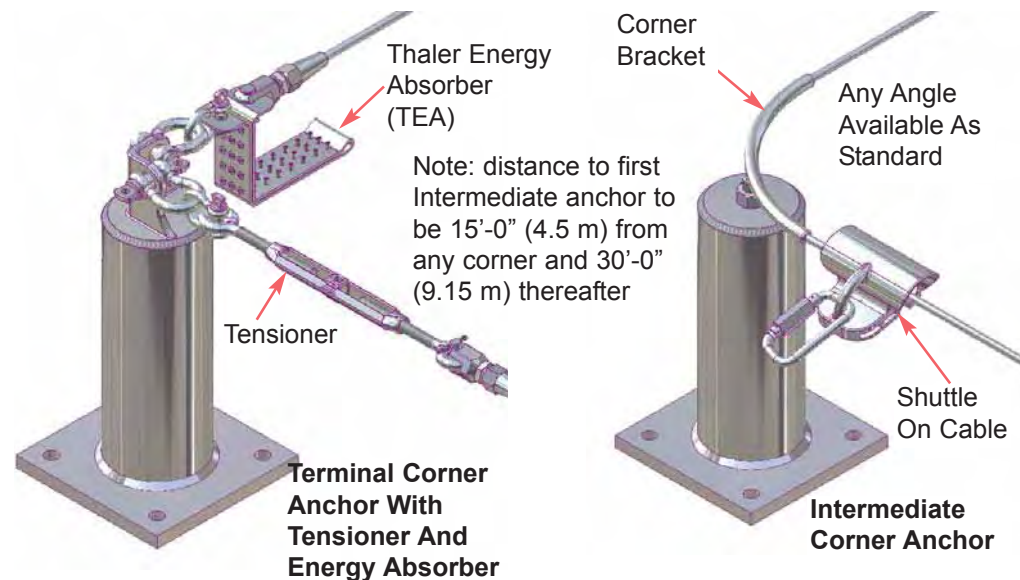

Note: distance to first Intermediate anchor to be 15'-0" (4.5 m) from any corner and 30'-0" (9.15 m) thereafter

Note: The Thaler K-700 EASY SLIDER Horizontal Lifeline is designed to protect up to 2 workers against falls from height for systems of length up to 200'-0" (61 m) and 4 workers for systems more than 200'-0" (61 m) long as standard.

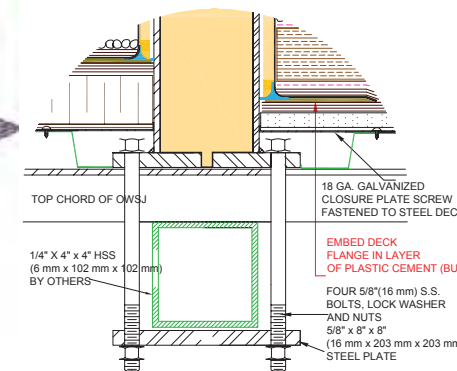
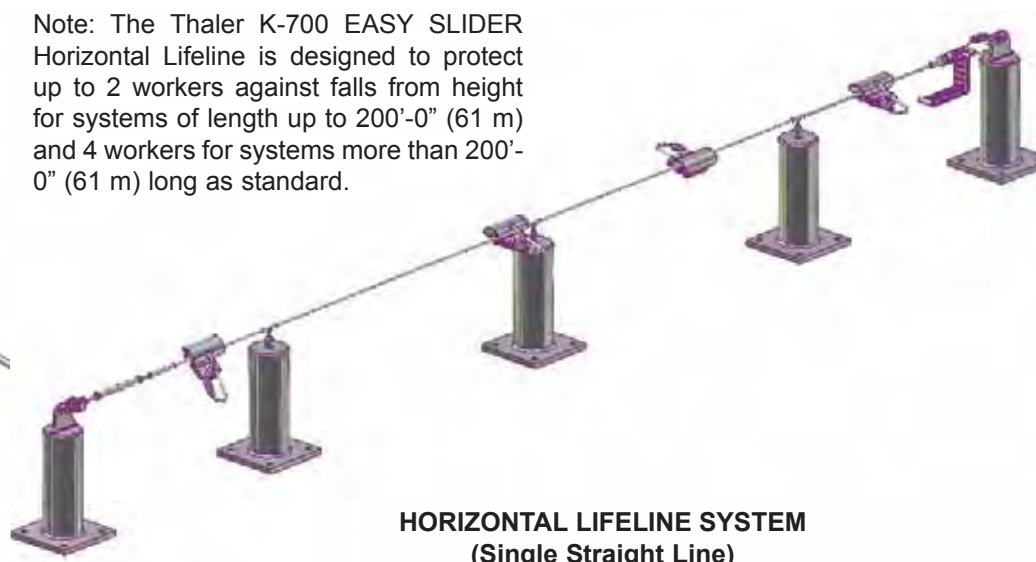

Bolt-Around OWSJ (K-FARA-6-700)

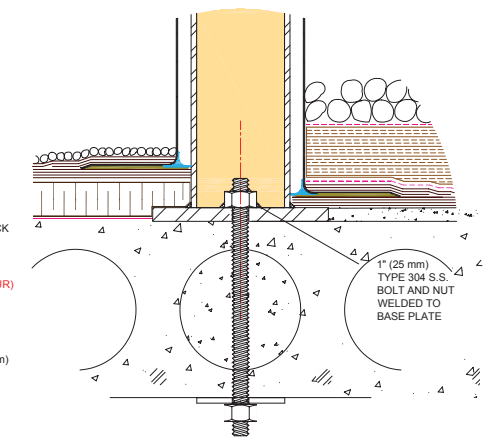

Hollow-Core Slab (K-FARA-7-700)

ROOF SPECIALTIES K-701 EASY SLIDER™ HORIZONTAL LIFELINE FALL PROTECTION SYSTEM (Wall Application)



Intermediate Wall Anchor
K-FARA-93-710
With Thaler EASY SLIDER Shuttle

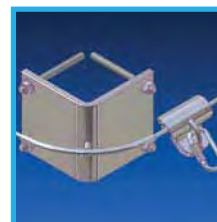

Corner Wall Anchor
K-FARA-93-711
With EASY SLIDER Shuttle (90° Angle Illustrated)

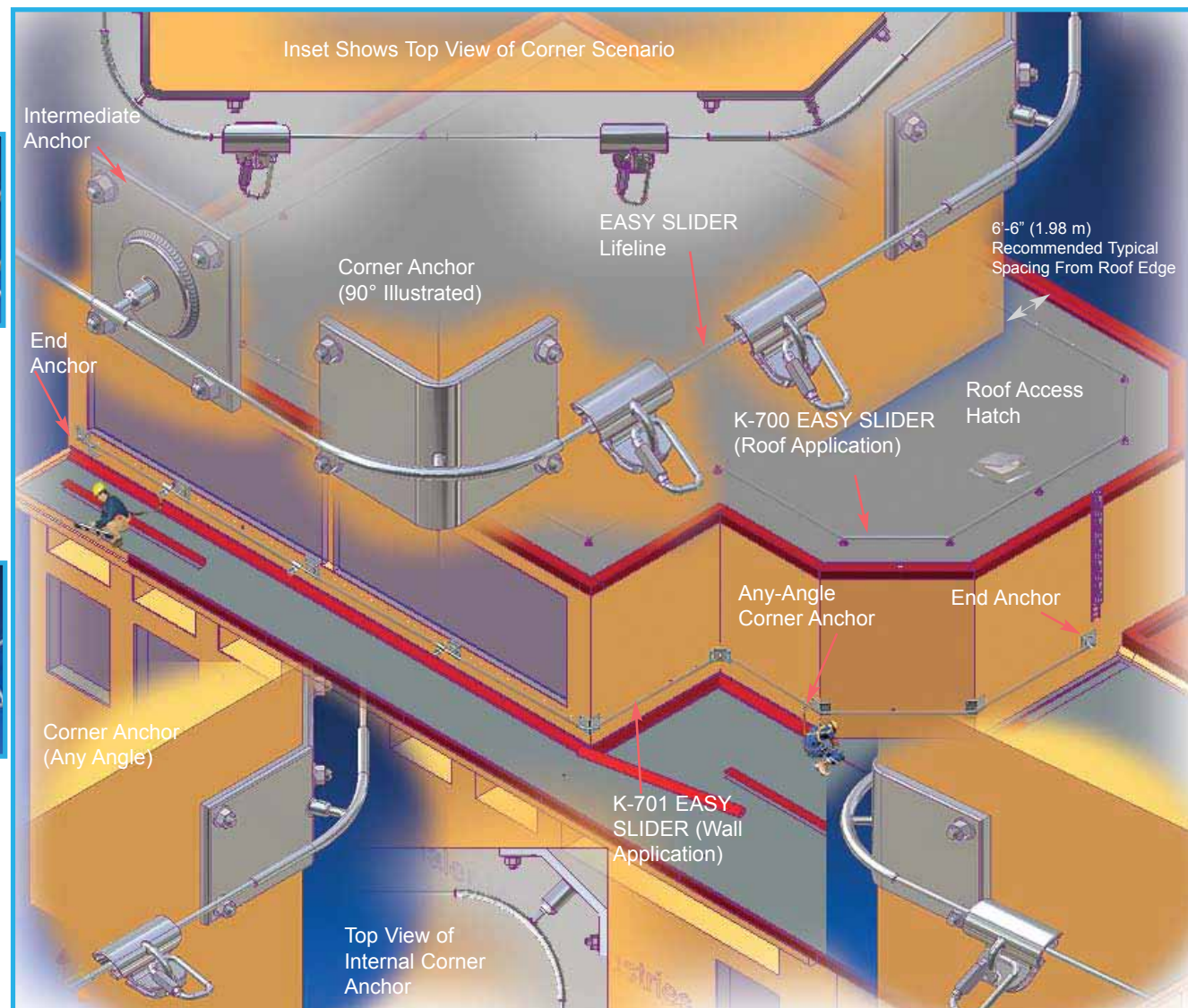

Montage Illustration Shows K-701 EASY SLIDER Horizontal Lifeline Fall Protection System For Walls

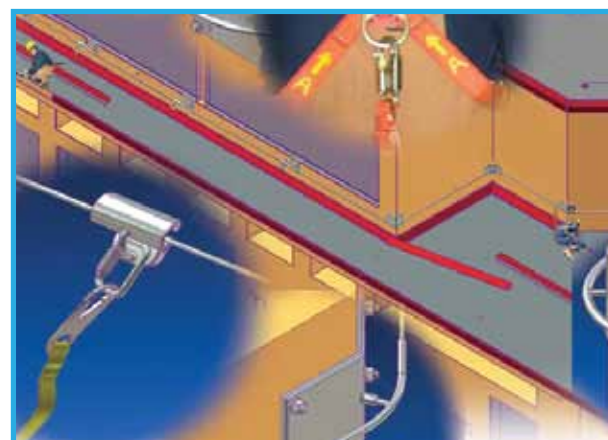

Maintenance Personnel Working Around Low Parapet and Narrow Roof Area, a Typical Fall Hazard Area

Terminal End Anchor K-FARA-93-709 (adhesive bolt fastening for retrofit applications)

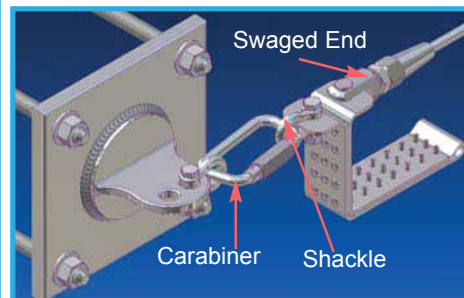

Terminal End Anchor K-FARA-93-709 With Thaler Energy Absorber (TEA). Adhesive Bolt Fastening For Retrofit Applications

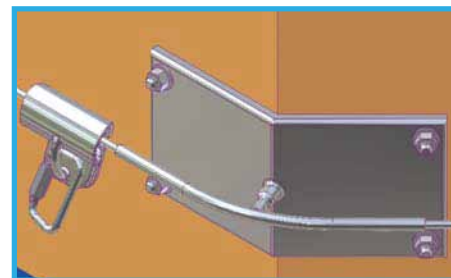

Any-Angle Corner Anchor K-FARA-93-712 And EASY SLIDER Shuttle



End Tensioner

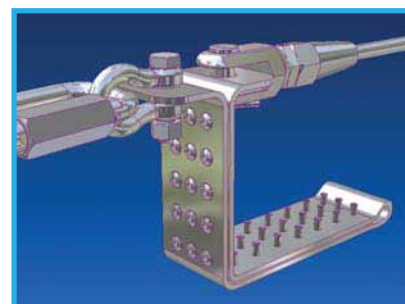

Thaler Energy Absorber (TEA)

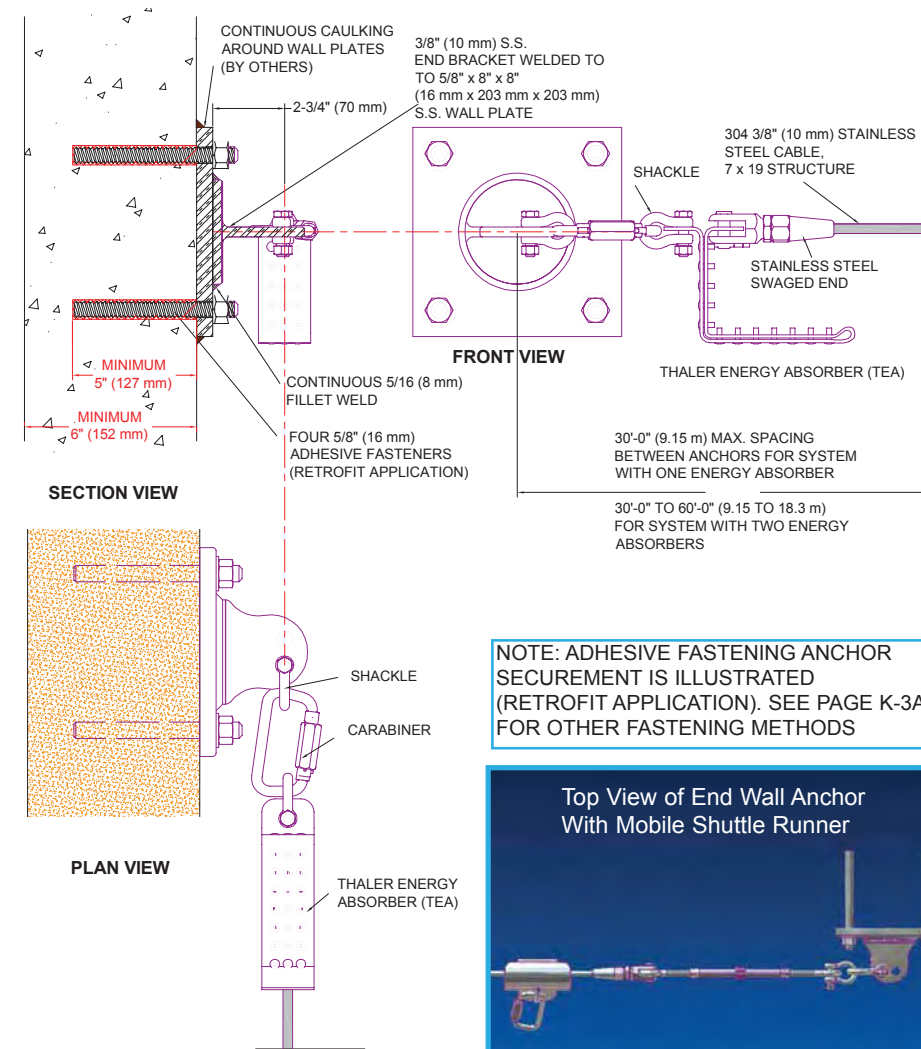

NOTE: ADHESIVE FASTENING ANCHOR SECUREMENT IS ILLUSTRATED (RETROFIT APPLICATION). SEE PAGE K-3A FOR OTHER FASTENING METHODS



Top View of End Wall Anchor With Mobile Shuttle Runner

TERMINAL END HORIZONTAL LIFELINE ANCHOR (K-FARA-93-709) PATENT PENDING

PLANNING SERVICE:

Thaler will provide layout drawings for the K-701 EASY SLIDER in compliance with all standards, safety regulations and local building codes.

SPECIFICATION (Short Form):

Horizontal lifeline system: Thaler K-701 EASY SLIDER Horizontal Lifeline fall protection system for walls to [CSA-Z91-02][OSHA 1910.66, Subparts D and F] with: stainless steel 3/8" (10 mm) brackets welded to stainless steel base plates 5/8" x 8" x 8" (16 mm x 203 mm x 203 mm), securement to suit substrate; Stainless steel fittings (swaged end, energy absorber, double locking carabiner, end tensioner, intermediate brackets, corner pieces); 304 s.s. cable, 3/8" (10 mm) dia. 7 x 19 structure; [2][4] fully body harnesses with integral shock absorber by others; manufactured by Thaler Metal Industries, 1-800-387-7217 (Mississauga, Ontario, Canada) or 1-800-576-1200 (New Braunfels, TX), installed as per manufacturer's written instructions. Provide 20 year warranty against defects in materials and/or manufacture. Caulking of wall plates by others.

INSTALLATION:

"Installation Instructions" are provided with every Thaler product. However, only Thaler or Thaler approved installers may install the the system which must be certified by a professional engineer prior to initial use. Essentially, the K-701 EASY SLIDER Horizontal Lifeline is installed by fastening anchors to the wall, or other structural substrate, installing cable, including fittings, and sealing the wall plates to surfaces where applicable.

Recommended Layout: Maximum spacing between anchors is 30'-0" (9.15 m) for system with one Thaler Energy Absorber (TEA), and from 30'-0" to 60'-0" (9.15 to 18.3 m) for system with two energy absorbers. Entry and exit points should be located in a safe area to ensure continuous protection. Horizontal lifeline should not be located closer than 6'-6" (1.98 m) from any roof edge except for narrow roof areas. For minimum clearance required below the level of the horizontal lifeline, see page K-1. Consult with Thaler for layout recommendations.

Ordering and Availability: Available throughout North America. Contact Thaler for list of distributors and current cost information. Products are typically available from stock.

DESCRIPTION:

The Thaler K-701, EASY SLIDER™ Horizontal Lifeline Fall Protection System for walls is a complete pre-engineered multi-span flexible lifeline system consisting of end wall anchors, intermediate anchors, stainless steel cable, mobile attachment devices (shuttle runners), in-line fittings (tensioner, tension indicator, energy absorber, corner fittings, etc.) and up to 4 shuttles as standard. Full body harnesses with 6'-0" (1.8 m) long shock absorbing lanyards (by others) completes the system. End and intermediate anchors consist of stainless steel base plates with s.s. end bracket with two holes. Anchors are also available with different type bases for fastening to wall or similar structures. All anchors are designed to resist without fracture a pull-out force of 5400 lbs (24.02 kN), applied in the most adverse direction.

PROMINENT FEATURES:

Designed to protect up to 2 workers against falls from height for systems in length up to 200'-0" (61 m) and 4 workers for the systems more than 200'-0" (61 m) as standard (from falling more than 6'-0" or 1.8 m). Hands free system allows users to walk uninterrupted the entire length of system. Thaler Energy Absorber (TEA), separate from harness shock absorber assists in dissipating or reducing fall arrest forces. EASY SLIDER shuttle permits worker to connect or disconnect at any position on cable. Line length is unlimited. Maintenance free. Anchor integrity is backed by high \$7,000,000.00 liability insurance.

OPTIONS:

Any-angle corner units available as standard. Any type securement to suit structural substrate (cast-in-place, bolted, welded, etc.).

RECOMMENDED USE:

Suitable for both travel restraint and fall arrest using full body harness and lanyard, self retracting lifeline or lifeline with rope grab. Provides fall protection for servicing rooftop equipment, roof inspection, accessing window cleaning stations and similar applications. Designed to protect up to four workers as standard. See K-700 and K-702 system for roof and overhead applications.

APPLICABLE STANDARDS:

Thaler K-700 EASY SLIDER conforms to all Canadian and U.S. standards, provincial and state labor/safety codes and materials standards relating to anchor fabrication and horizontal lifeline applications. Conformance includes CSA, OML, ASME, ANSI, IWCA, OSHA, CAL OSHA, AISC, AWS, and other references. See Thaler EASY SLIDER Horizontal Lifeline Primer literature for introductory data on subject of fall protection.

WARRANTY:

20 year warranty (lifetime on all stainless steel) against defects in materials and/or manufacture when installed in accordance with Thaler "Installation Instructions".

MAINTENANCE:

Regulatory authorities require the horizontal lifeline system be inspected annually with inspection data (date, inspector's name and comments) recorded in the Fall Protection Maintenance Log book. Apart from this requirement, the K-701 EASY SLIDER stainless steel cable only requires occasional wiping with a damp cloth to ensure free and easy movement of the shuttle component. In the event of a fall, the system including any affected harness, must be re-approved by a professional engineer before being placed back in service. Inspection of caulking around wall plates should be carried under regular roof inspection procedures.

Note: All Anchors are designed to resist without fracture a pull-out force of 5400 lbs (24.02 kN), applied in the most adverse direction

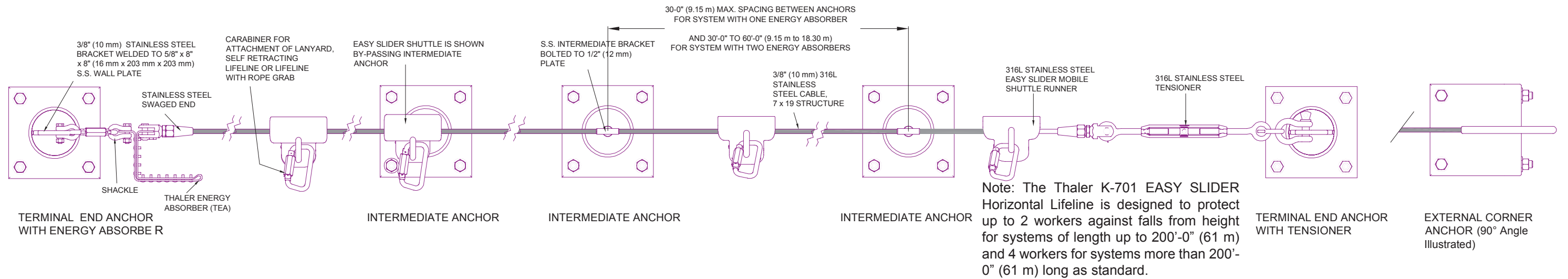

FRONT ELEVATION OF K-701 EASY SLIDER WALL MOUNTED HORIZONTAL LIFELINE SYSTEM

FASTENING METHODS FOR DIFFERENT STRUCTURES

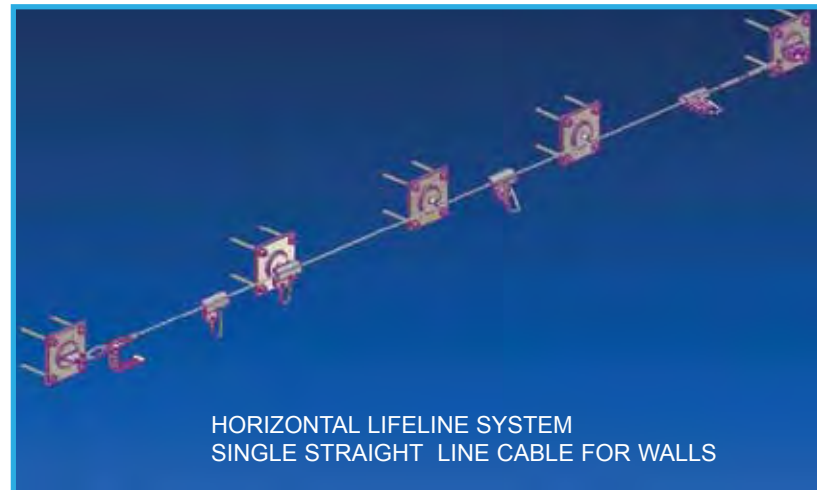

HORIZONTAL LIFELINE SYSTEM
SINGLE STRAIGHT LINE CABLE FOR WALLS

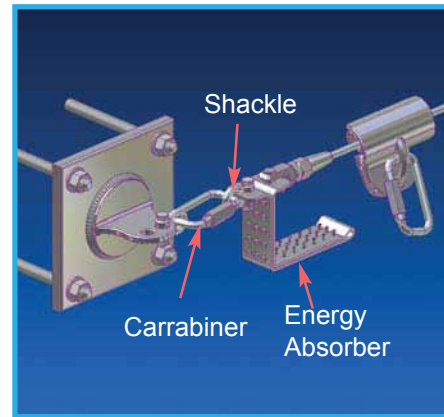

TERMINAL END WALL ANCHOR
WITH ENERGY ABSORBER AND
SWAGED END

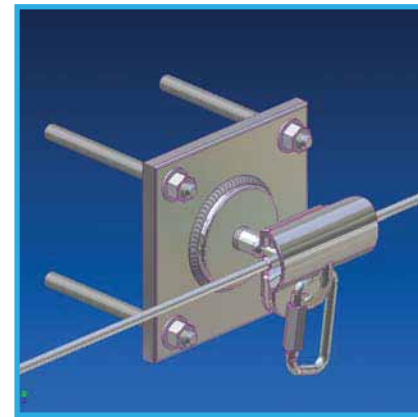

INTERMEDIATE ANCHOR WITH EASY
SLIDER SHUTTLE BY-PASSING
INTERMEDIATE BRACKET

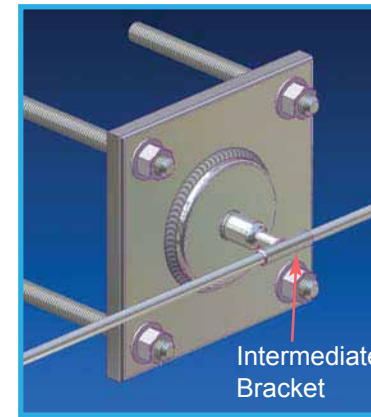

WALL INTERMEDIATE
ANCHOR

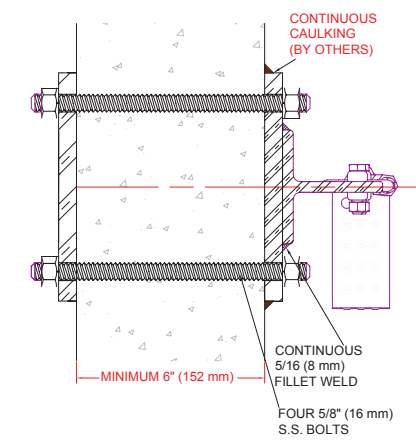

BOLT THROUGH FASTENING
(K-FARA-91-701) SECTION DETAIL

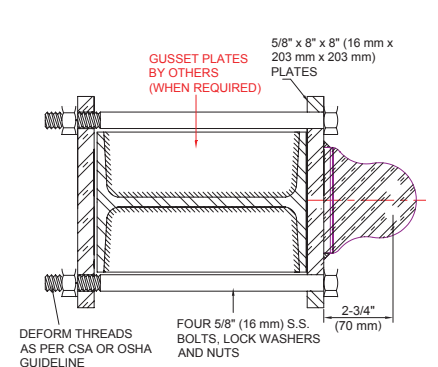

BOLT AROUND BEAM
(K-FARA-701) FASTENING
SECTION DETAIL



INTERNAL CORNER ANCHOR (90°
Angle Illustrated)

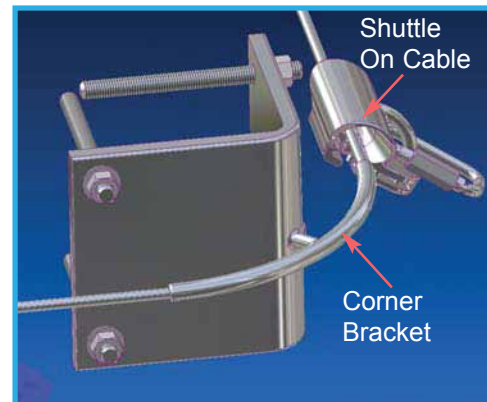

EXTERNAL CORNER ANCHOR (90°
Angle Illustrated)



EXTERNAL CORNER ANCHOR
(Any Angle Bracket Available As
Standard)

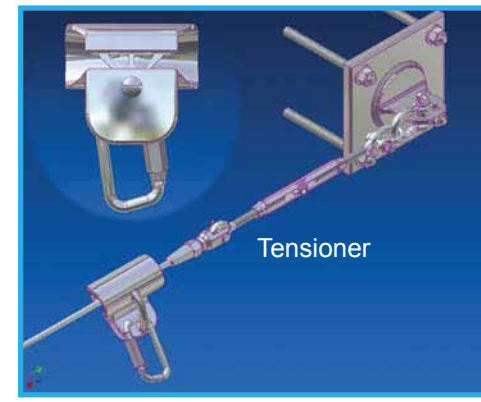

TERMINAL END ANCHOR WITH
TENSIONER (Inset shows Underside
of Shuttle)

For adhesive fastening
(K-FARA-93-701), see front side
of page for retrofit applications

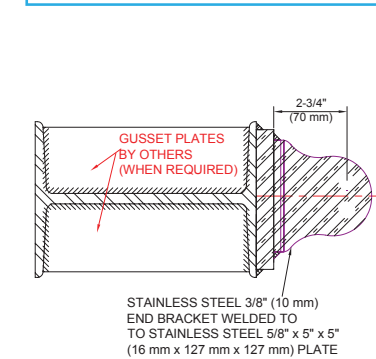

WELDED TO BEAM (K-FARA-701)
FASTENING

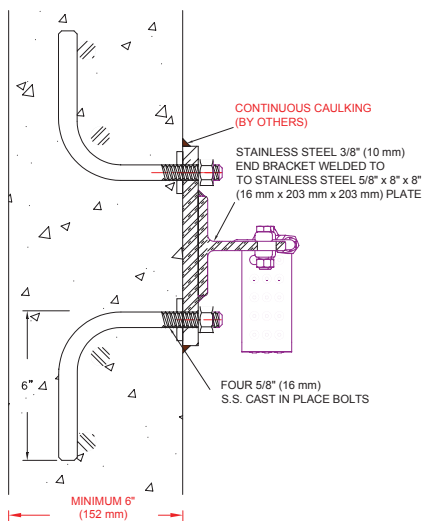

CAST-IN-PLACE
(K-FARA-92-701)
SECTION DETAIL



Close Up View of Mobile Shuttle Runner With Carabiner Attached



View Shows Underside of Shuttle Runner



K-702 EASY SLIDER Horizontal Lifeline Provides Fall Protection For Window Cleaning



Terminal Anchor With Thaler Energy Absorber (TEA)



Terminal Anchor With End Tensioner



Intermediate Anchor With By-Pass Bracket



Corner Anchor With Any-Angle By-Pass Bracket



Terminal End Anchor With Thaler Energy Absorber (TEA)

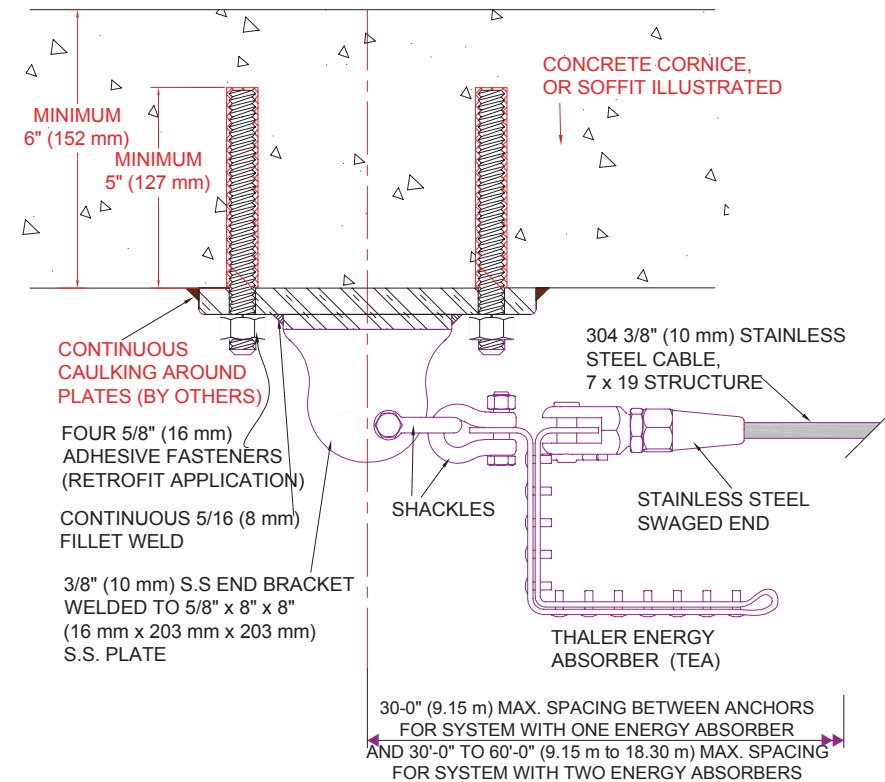
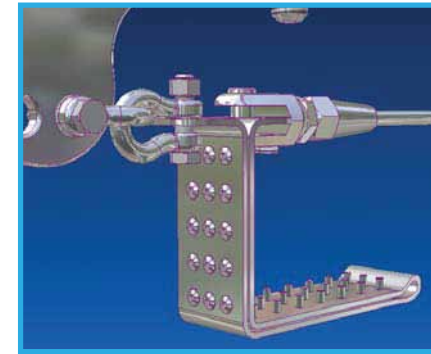

K-702 HORIZONTAL LIFELINE TERMINAL END ANCHOR (K-FARA-93-713) PATENT PENDING

PLANNING SERVICE:

Thaler will provide layout drawings for the K-701 EASY SLIDER in compliance with all standards, safety regulations and local building codes.

SPECIFICATION (Short Form):

Horizontal lifeline system: Thaler K-702 EASY SLIDER Overhead Horizontal Lifeline fall protection system for overhead or similar applications to [CSA-Z91-02][OSHA 1910.66, Subparts D and F][OSHA 1926.500, Subpart M (Construction)] with: stainless steel 3/8" (10 mm) brackets welded to stainless steel base plates 5/8" x 8" x 8" (16 mm x 203 mm x 203 mm), securement to suit substrate; Stainless steel fittings (swaged end, energy absorber, double locking carabiner, end tensioner, intermediate brackets, corner pieces); 304 s.s. cable, 3/8" (10 mm) dia. 7 x 19 structure; [2][4] fully body harnesses with integral shock absorber (by others); manufactured by Thaler Metal Industries, 1-800-387-7217 (Mississauga, Ontario, Canada) or 1-800-576-1200 (New Braunfels, TX), installed as per manufacturer's written instructions. Provide 20 year warranty against defects in materials and/or manufacture. Caulking of anchors plates by others.

INSTALLATION:

"Installation Instructions" are provided with every Thaler product. However, only Thaler Metal Industries, Thaler approved installers or competent installers following Thaler Installation Instruction may install the the system which must be certified by a professional engineer prior to initial use. Essentially, the K-702 EASY SLIDER Horizontal Lifeline is installed by fastening the anchors to a soffit, cornice, or other structural substrate, installing cable, including fittings and sealing the plates to surfaces where applicable.

Recommended Layout: Maximum spacing between anchors posts is 30'-0" (9.15 m) for the system with one energy absorber and 30'-0" (9.15 m) to 60'-0" (18.3 m) for the system with two energy absorbers. Entry and exit points should be located in a safe area to ensure continuous protection. Horizontal lifeline ideally should not be located closer than 6'-6" (1.98 m) from any roof edge except for narrow roof areas. For minimum clearance required below the level of the horizontal lifeline, see page K-1. Consult with Thaler for layout recommendations.

Ordering and Availability: Available throughout North America. Contact Thaler for list of distributors and current cost information. Products are typically available from stock.

ROOF SPECIALTIES K-702 EASY SLIDER™ HORIZONTAL LIFELINE FALL PROTECTION SYSTEM (Overhead Application)

DESCRIPTION:

The Thaler K-702, EASY SLIDER™ Horizontal Lifeline Fall Protection System for overhead application is a complete pre-engineered multi-span flexible lifeline system consisting of terminal end anchors, intermediate anchors, stainless steel cable, mobile attachment devices (shuttle runners), in-line fittings (tensioner, energy absorber, corner fittings, etc.) and up to 4 shuttles. Full body harnesses with 6'-0" (1.8 m) long shock absorbing lanyards (by others) completes the assembly. End and intermediate anchors consist of a stainless steel base plate and end bracket with two holes. Anchors are also available with different type bases for fastening to a variety of overhead or similar structures. All anchors are designed to resist without fracture a pull-out force of 5400 lbs (24.02 kN), applied in the most adverse direction.

PROMINENT FEATURES:

Designed to protect up to 2 workers against falls from height for systems in length up to 200'-0" (61 m) and 4 workers for the systems more than 200'-0" (61 m) as standard (prevents users from falling more than 6'-0" or 1.8 m). Hands free system allows users to walk uninterrupted the entire length of system. Thaler Energy Absorber (TEA), separate from harness shock absorber assists in dissipating or reducing fall arrest forces. EASY SLIDER shuttle permits worker to connect or disconnect at any position on cable. Maintenance free. Anchor integrity is backed by high \$7,000,000.00 liability insurance.

OPTIONS:

Any-angle corner units available as standard. Any type securement to suit structural substrate (cast-in-place, bolted, welded, etc.).

RECOMMENDED USE:

Suitable for both travel restraint and fall arrest using full body harness and lanyard, self retracting lifeline or lifeline with rope grab. Provides fall protection for servicing rooftop equipment, roof inspection, accessing window cleaning stations and similar applications. Designed to protect up to four workers. Line length is unlimited. See K-700 and K-701 system for roof and wall applications.

APPLICABLE STANDARDS:

Thaler K-702 EASY SLIDER conforms to all Canadian and U.S. standards, provincial and state labor/safety codes and materials standards relating to anchor fabrication and horizontal lifeline applications. Conformance includes CSA, OML, ASME, ANSI, IWCA, OSHA, CAL OSHA, AISC, AWS, and other references. See Thaler EASY SLIDER Horizontal Lifeline Primer literature for introductory data on subject of fall protection.

WARRANTY:

20 year warranty (lifetime on all stainless steel) against defects in materials and/or manufacture when installed in accordance with Thaler "Installation Instructions".

MAINTENANCE:

Regulatory authorities require the horizontal lifeline system be inspected annually with inspection data (date, inspector's name and comments) recorded in the Fall Protection Maintenance Log book. Apart from this requirement, the K-702 EASY SLIDER stainless steel cable only requires occasional wiping with a damp cloth to ensure free and easy movement of the shuttle component. In the event of a fall, the system including any affected harness, must be re-approved by a professional engineer before being placed back in service. Inspection of caulking around plates should be carried out under regular roof inspection procedures.

Note: All Anchors are designed to resist without fracture a pull-out force of 5400 lbs (24.02 kN), applied in the most adverse direction

Note: The Thaler K-700 EASY SLIDER Horizontal Lifeline is designed to protect up to 2 workers against falls from height for systems of length up to 200'-0" (61 m) and 4 workers for systems more than 200'-0" (61 m) long as standard.

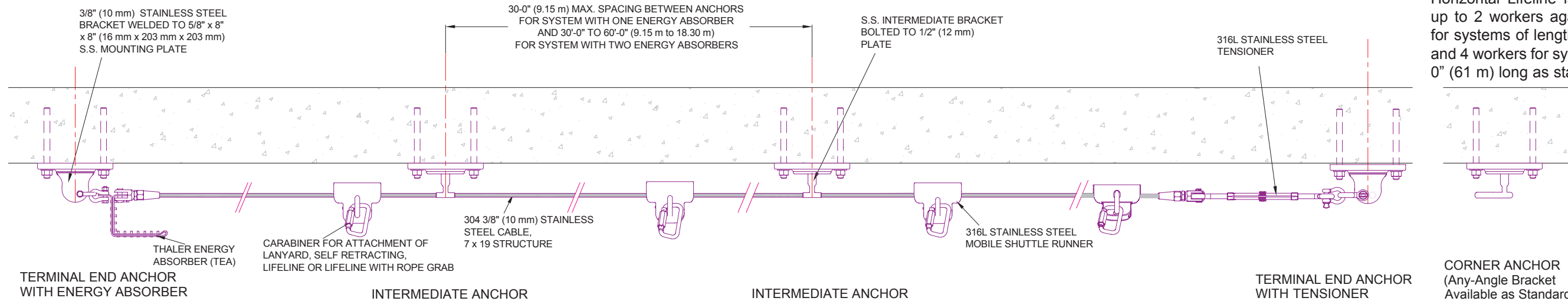

FRONT ELEVATION OF K-702 EASY SLIDER OVERHEAD MOUNTED HORIZONTAL LIFELINE SYSTEM

FASTENING METHODS FOR DIFFERENT STRUCTURES

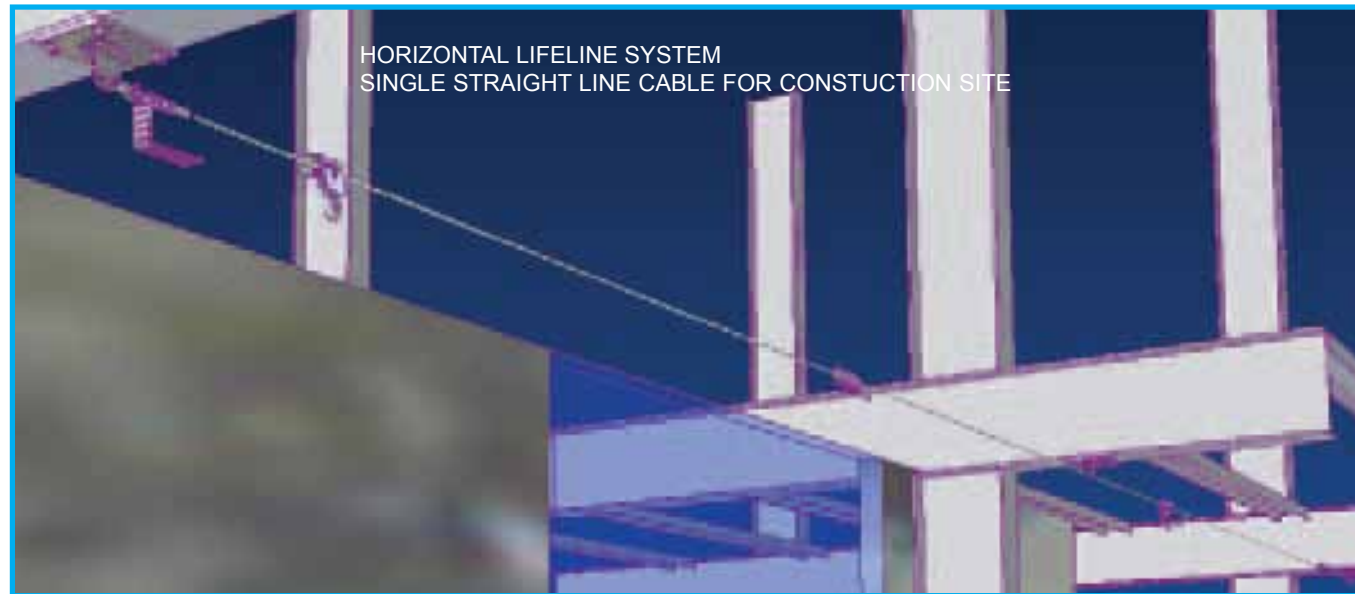

HORIZONTAL LIFELINE SYSTEM
SINGLE STRAIGHT LINE CABLE FOR CONSTRUCTION SITE

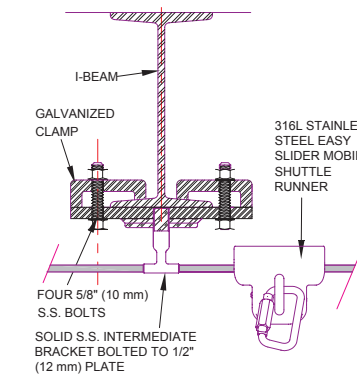

TEMPORARY CLAMP AROUND BEAM FLANGE (K-FARA-91-702) SECTION DETAIL FOR CONSTRUCTION APPLICATIONS

For Adhesive Bolt (K-FARA-93-702) Fastening for Retrofit Application, See Top of Page and Front Side of Page

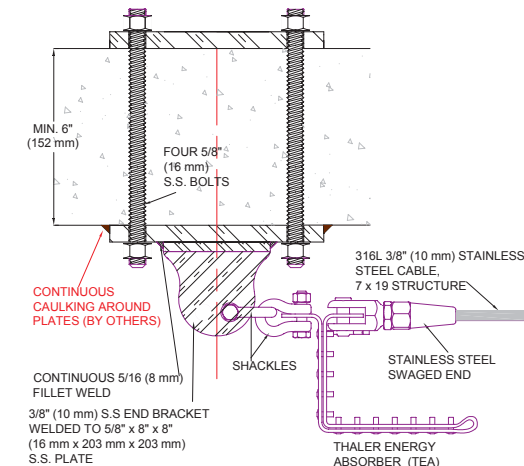

BOLT THROUGH (K-FARA-91-702) SECTION DETAIL

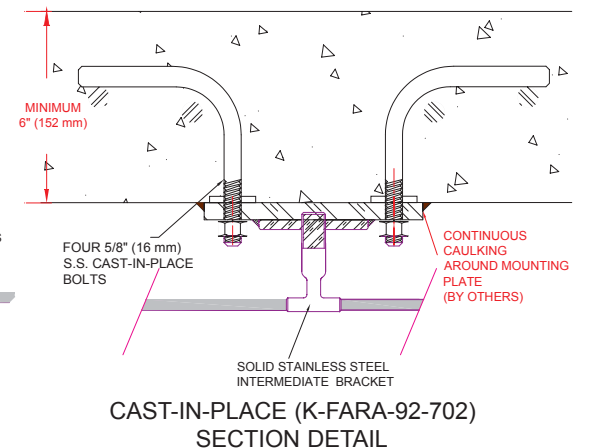

CAST-IN-PLACE (K-FARA-92-702) SECTION DETAIL

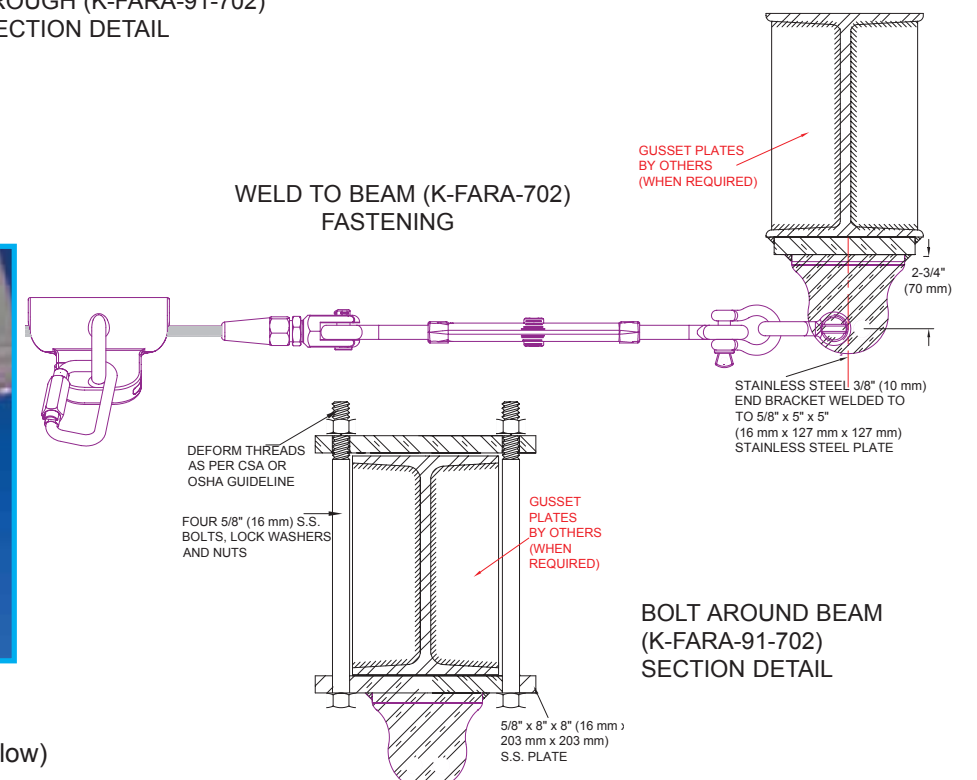

WELD TO BEAM (K-FARA-702) FASTENING

BOLT AROUND BEAM (K-FARA-91-702) SECTION DETAIL

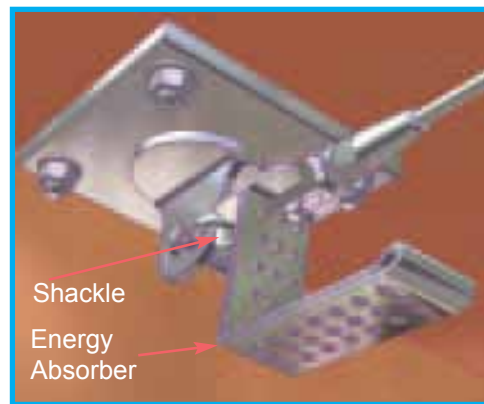

TERMINAL END ANCHOR WITH ENERGY ABSORBER AND SWAGED END

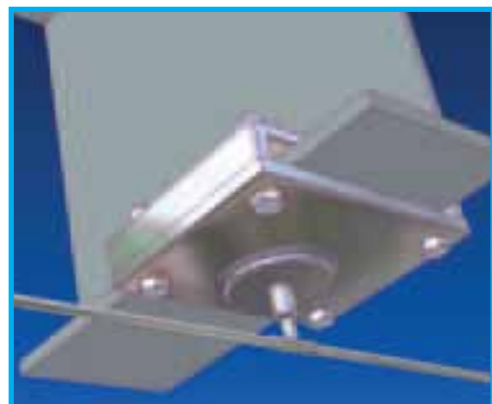

INTERMEDIATE ANCHOR CONSTRUCTION CLAMP (Temporary)

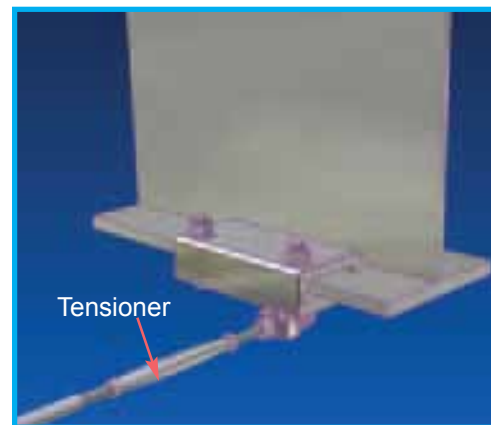

TERMINAL END ANCHOR WITH TENSIONER (Temporary. View From Above)

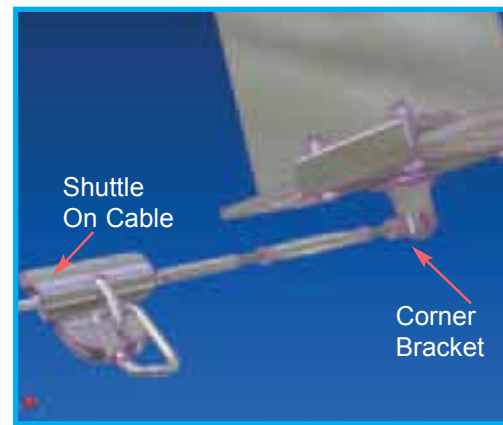

TERMINAL END ANCHOR WITH TENSIONER (Temporary. View From Below)



End Anchor With Thaler Energy Absorber (TEA) and Swaged End



End Anchor With Tensioner

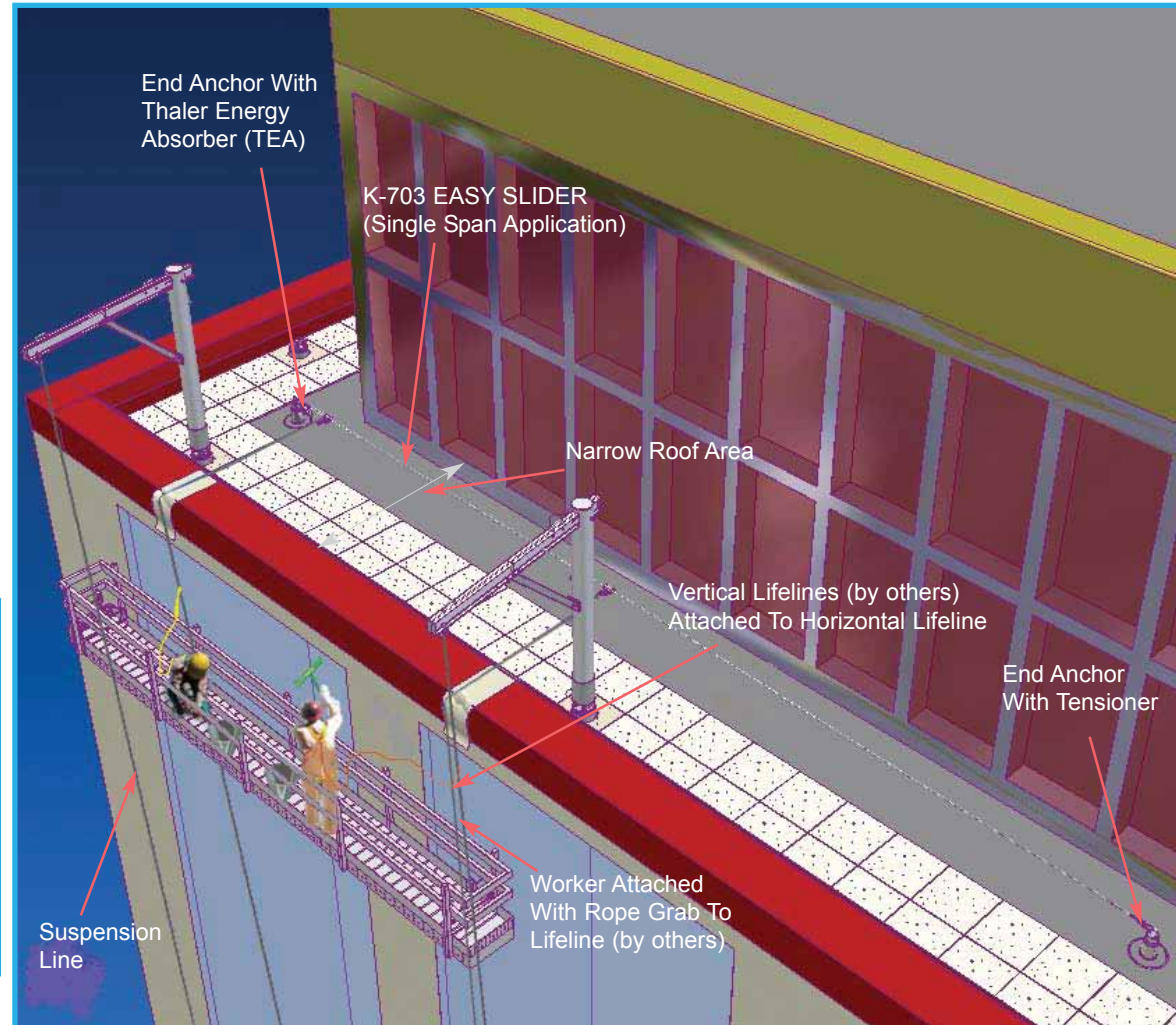
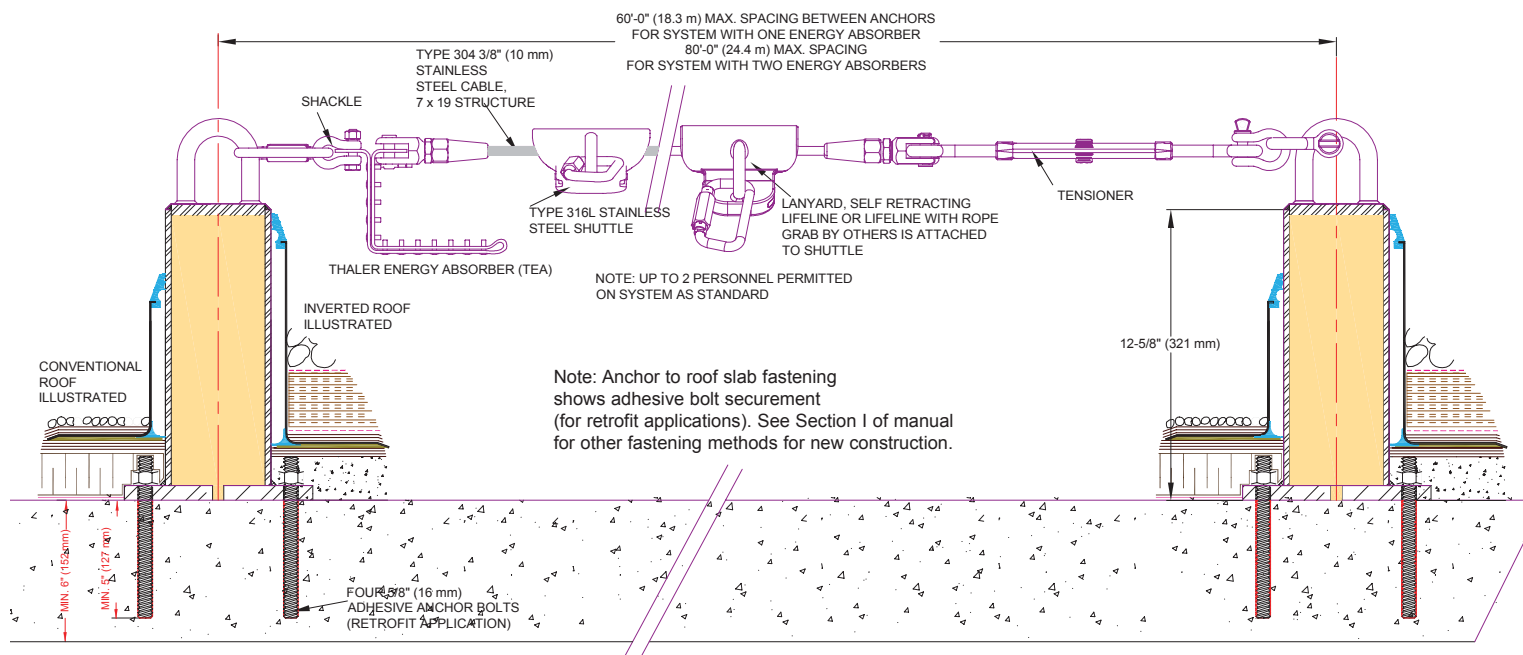

Illustration Shows K-703 EASY SLIDER Horizontal Lifeline Fall Protection System For Single Span Application



K-703 Horizontal Lifeline Single Span Application

Note: For Minimum Fall Clearance Required Below System See Page K-1



Close-Up View of Mobile Shuttle Runner. Inset shows Underside of Shuttle

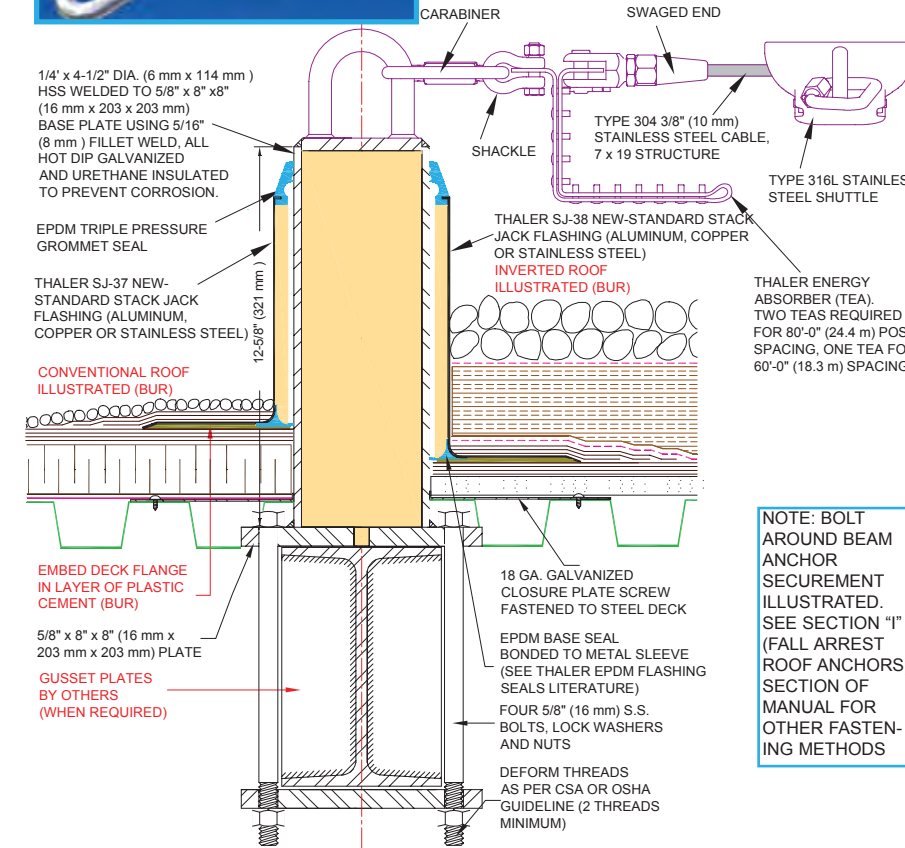

NOTE: BOLT AROUND BEAM ANCHOR SECUREMENT ILLUSTRATED. SEE SECTION "I" (FALL ARREST ROOF ANCHORS) SECTION OF MANUAL FOR OTHER FASTENING METHODS

TERMINAL END HORIZONTAL LIFELINE ANCHOR (K-FARA-13-717)
PATENT PENDING

PLANNING SERVICE:

Thaler will provide layout drawings for the K-703 EASY SLIDER in compliance with all standards, safety regulations and local building codes.

SPECIFICATION (Short Form):

Horizontal lifeline system: Thaler K-703 EASY SLIDER Horizontal Lifeline fall protection system to [CSA-Z91-02][OSHA 1910.66, Subparts D and F] with: 4-1/2" (114 mm) dia. urethane insulated HSS anchor posts, wall thickness 1/4" (6 mm), hot dipped galvanized ASTM 500, 12" (305 mm) high, welded and bolted to 5/8" x 8" x 8" (16 mm x 203 mm x 203 mm) 44W base plate, securement to suit substrate; stainless steel fittings (swaged end, energy absorber, double locking carabiner, shuttles, end tensioner); Type 304 s.s. cable, 3/8" (10 mm) dia. 7 x 19 structure; [1][2] full body harnesses with integral shock absorber by others; [SJ-34 (uninsulated) or SJ-37 (insulated), 7" (178 mm) high] [SJ-35 (uninsulated) or SJ-38 (insulated), 13" (330 mm) high] New-Standard STACK JACK Flashing of [.064" (1.6 mm) mill finish 1100-OT alloy aluminum] [.032" (0.831 mm) 24 oz. copper] [.031" (0.79 mm) 22 ga. Type 304 stainless steel] to CSA B272-93, with EPDM Triple Pressure Grommet Top Seal and EPDM Base Seal and [bituminous painted deck flange] [PVC coated deck flange]; manufactured by Thaler Metal Industries, 1-800-387-7217 (Mississauga, Ontario, Canada) or 1-800-576-1200 (Niagara Falls, NY), installed as per manufacturer's written instructions. Provide 20 year warranty against leaks, condensation and defects in materials and/or manufacture.

INSTALLATION:

"Installation Instructions" are provided with every Thaler product. However, only Thaler Metal Industries, Thaler approved installers or competent installers following Thaler Installation Instructions may install the system which must be certified by a professional engineer prior to initial use. Essentially, the K-703 EASY SLIDER Horizontal Lifeline is installed by fastening the anchor posts on the roof structural substrate, installing flashing, and cable, including fittings.

Recommended Layout: Maximum spacing between anchor posts is 80'-0" (24.4 m) for system with two energy absorbers, and 60'-0" (18.3 m) for system with one energy absorber. Horizontal lifeline should not be located closer than 6'-6" (1.98 m) from any roof edge. For minimum clearance required below the level of the horizontal lifeline, see page K-1. Consult with Thaler for layout recommendations.

Ordering and Availability: Available throughout North America. Contact Thaler for list of distributors and current cost information. Products are typically available from stock.

ROOF SPECIALTIES
K-703 EASY SLIDER™
HORIZONTAL LIFELINE
FALL PROTECTION SYSTEM
(Single Span Application)

DESCRIPTION:

The Thaler K-703 EASY SLIDER™ Horizontal Lifeline Fall Protection System is a complete pre-engineered single-span flexible lifeline system consisting of end anchors, stainless steel cable, mobile attachment devices (shuttle runners), in-line fittings (tensioner, tension indicator, energy absorber, etc.) and up to 2 shuttles as standard. Full body harnesses with 6'-0" (1.8 m) long shock absorbing lanyards (by others) completes the assembly. End anchors consist of urethane insulated hollow steel posts (HSS) with stainless steel U-bolt eye to accommodate the cable, and time-tested Thaler STACK JACK Flashing. Anchors are also available with different type bases for fastening to a variety of roof structures. All anchor posts are designed to resist without fracture a pull-out force of 5400 lbs (24.02 kN), applied in the most adverse direction.

PROMINENT FEATURES:

Designed to protect up to 2 workers against falls from height for systems of length up to 80'-0" (24.4 m) as standard (prevents users from falling more than 6'-0" or 1.8 m). Hands free system allows users to walk uninterrupted the entire length of system. Thaler Energy Absorber (TEA), separate from harness shock absorber, assists in dissipating or reducing fall arrest forces. EASY SLIDER shuttle requires worker to connect or disconnect at any position on cable. Condensation free and maintenance free (attractive, neat flashing never needs caulking. See Thaler EPDM Flashing Seals literature. Anchor integrity is backed by high \$7,000,000.00 liability insurance.

OPTIONS:

Any type securement to suit structural substrate (cast-in-place, bolted, welded, etc.). PVC coated flashing deck flange for PVC roof membrane, bituminous painted flashing deck flange for BUR and ModBit roof membrane. Flashing is available aluminum, copper or stainless steel.

RECOMMENDED USE:

Suitable for both travel restraint and fall arrest using full body harness and lanyard, self retracting lifeline or lifeline with rope grab. Provides fall protection for window cleaning, servicing rooftop equipment, roof inspection, accessing window cleaning stations and similar applications on flat or low slope roofs. Designed to protect up to two workers (as standard) on system.

APPLICABLE STANDARDS:

Thaler K-703 EASY SLIDER conforms to all Canadian and U.S. standards, provincial and state labor/safety codes and materials standards relating to anchor fabrication and horizontal lifeline applications. Conformance includes CSA, OML, ASME, ANSI, IWCA, OSHA, CAL OSHA, AISC, AWS, and other references. See Thaler EASY SLIDER Horizontal Lifeline Primer literature for introductory data on subject of fall protection.

WARRANTY:

20 year warranty (lifetime on all stainless steel) against leaks, condensation and defects in materials and/or manufacture when installed in accordance with Thaler "Installation Instructions".

MAINTENANCE:

Regulatory authorities require the horizontal lifeline system be inspected annually with inspection data (date, inspector's name and comments) recorded in the Fall Protection Maintenance Log book. Apart from this requirement, the K-703 EASY SLIDER stainless steel cable only requires occasional wiping with a damp cloth to ensure free and easy movement of the shuttle component. In the event of a fall, the system including any affected harness, must be re-approved by a professional engineer before being placed back in service.

**K-700 EASY SLIDER HORIZONTAL LIFELINE
FALL PROTECTION SYSTEM (Roof Application)**

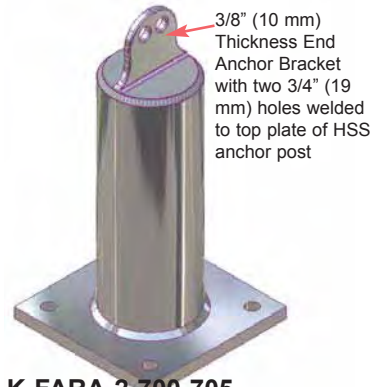

**K-FARA-2-700-705
End Anchor**

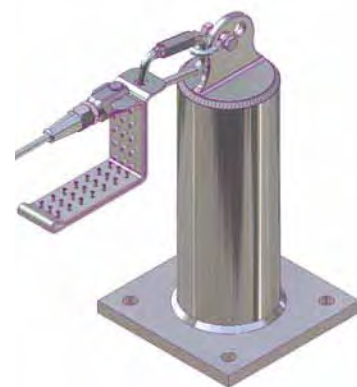

**K-FARA-2-700-705 With TEA
(Thaler Energy Absorber)**



**K-FARA-2-700-705 With
Tensioner**



**K-FARA-2-700-706 Start And
End Corner Anchor**

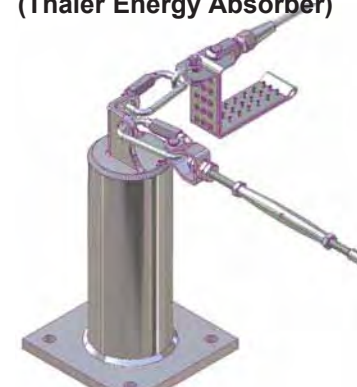

**K-FARA-2-700-707 Intermediate
Anchor**



**Intermediate Anchor
Bracket**

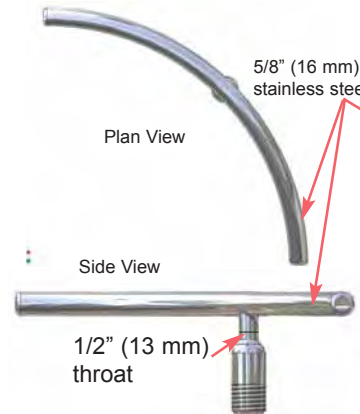

90° Corner Anchor Bracket

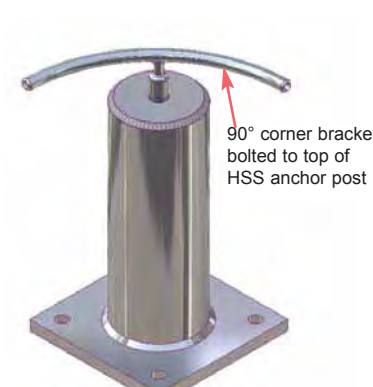

**K-FARA-2-700-708
Intermediate 90° Corner
Anchor**

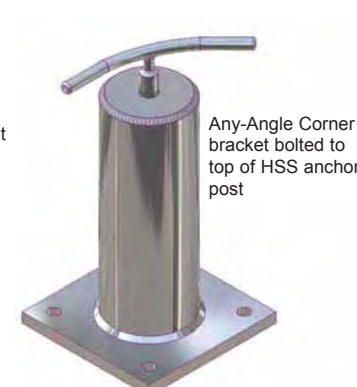

**K-FARA-2-700-709 Any-
Angle Corner Anchor**

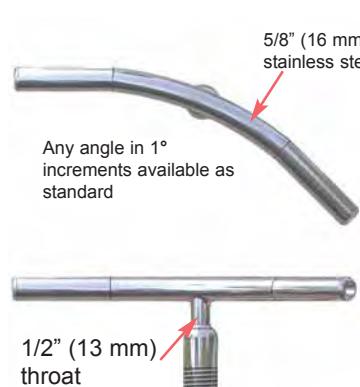

**Any-Angle Corner Anchor
Bracket**

**K-701 EASY SLIDER HORIZONTAL LIFELINE
FALL PROTECTION SYSTEM (Wall Application)**

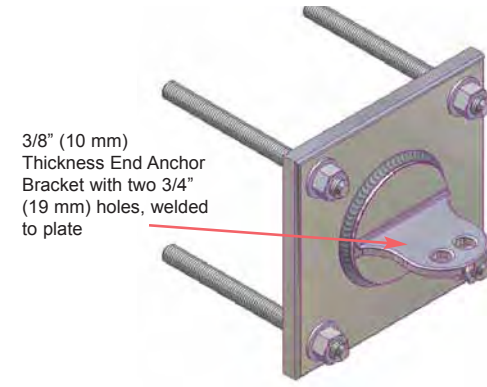

K-FARA-93-701-710 End Anchor

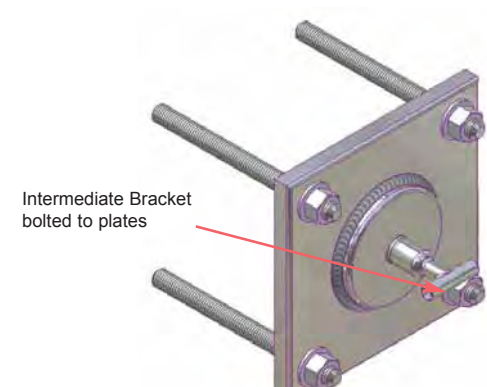

K-FARA-93-701-711 Intermediate Anchor

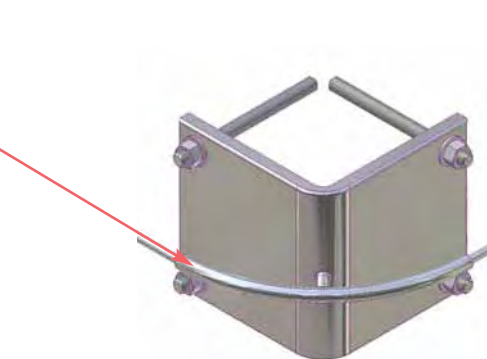

K-FARA-93-701-712 90° Corner Anchor

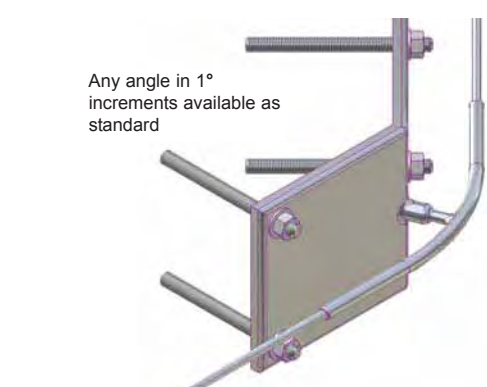

K-FARA-93-701-713 Any Angle Corner Anchor

**K-702 EASY SLIDER HORIZONTAL LIFELINE
FALL PROTECTION SYSTEM (Overhead
Application)**

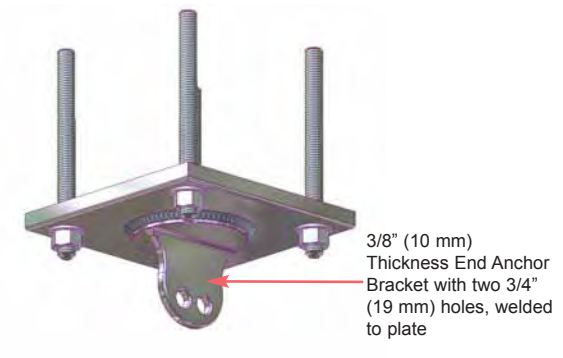

K-FARA-93-702-710 End Anchor

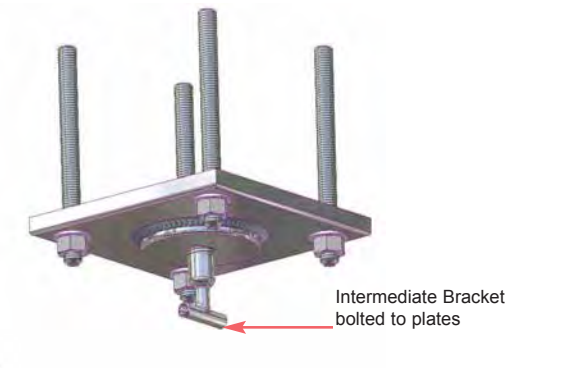

K-FARA-93-702-711 Intermediate Anchor

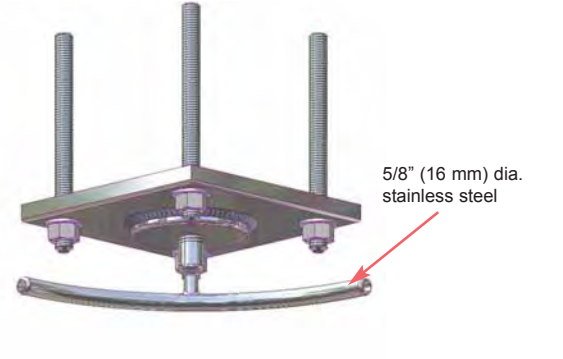

K-FARA-93-702-713 90° Corner Anchor



**K-FARA-93-702-714 Any-Angle Corner
Anchor**

**K-703 EASY SLIDER HORIZONTAL
LIFELINE FALL PROTECTION
SYSTEM (Single Span Application)**



K-FARA-12U-703 End Anchor

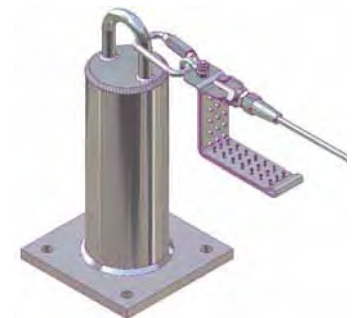

**K-FARA-12U-703 End Anchor With TEA
(Thaler Energy Absorber)**



**K-FARA-12U-703 End Anchor With
Tensioner**

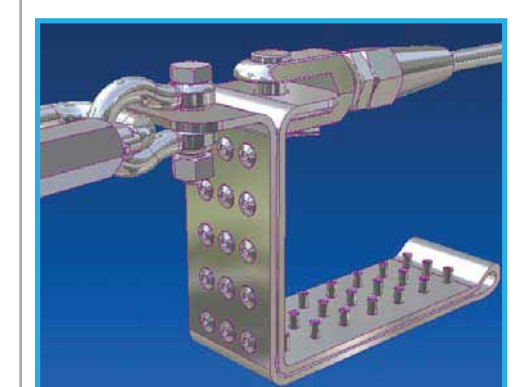

K-716 Thaler Energy Absorber (TEA)

Note: This horizontal lifeline specification, with minor editing, has been written as a separate section of work. Alternatively, the appropriate clauses may be incorporated as part of a roofing specification in regions where this feature is desired.

PART 1: GENERAL

1.01 SECTION INCLUDES

- A. Supply and installation of roof accessories, including:
 - 1. [Roof][Wall][Overhead] anchors
 - 2. Horizontal lifeline
 - 3. Preformed metal flashing

1.02 RELATED SECTIONS

- A. Section 03300 - Cast-in-Place Concrete
- B. Section 05210 - Steel Joists
- C. Section 05300 - Metal Deck
- D. Section 06100 - Rough Carpentry
- E. Section 07200 - Thermal Protection
- F. Section 07500 - Membrane Roofing
- G. Section 07900 - Joint Sealers

1.03 REFERENCES

- A. The work of this Section to conform to:

Canadian

- 1. National Standards of Canada

- A. CAN/CSA-Z91-02 (Safety Code for Window Cleaning Operations).
- B. CAN/CSA-Z271-98 (Safety Code for Suspended Elevating Platforms).

- 2. Canadian Standards Association

- A. CSA G40.21-M1987, M350W and M300W (Structural Quality Steels).
- B. CSA W47.1-1983 (Certification of Companies for Fusion Welding of Steel Structures).
- C. CSA W59-M1989 (Welded Steel Construction - Metal ARC Welding).
- D. CSA G164-M1981 (Hot Dip Galvanizing of Irregularly Shaped Articles).

- 3. Ontario Ministry of Labour

- A. Ontario Regulation 859 (Window Cleaning).

4. Ontario New Home Warranty Program

A. ONHWP Condominium Construction Guide (Chapter 12 - Roof Anchors).

5. Canadian General Standards Board

A. CGSB-51-GP 46MP (Manual for Installers of Spray Urethane Foam Thermal Insulation).

6. Canadian Urethane Foam Contractor's Association

A. CUFCA Manual for Installers of Spray Polyurethane Foam Thermal Insulation.

United States

7. Occupational Safety & Health Administration (U.S. Department of Labor)

A. OSHA 1910.28 SubPart D (Walking-Working Surfaces).

B. OSHA 1920.28 Safety Requirements for Scaffolding.

C. OSHA 1910.66, SubPart F (Powered Platforms, Manlifts, and Vehicle-Mounted Work Platforms).

D. OSHA 1926.500, SubPart M (Fall Protection).

E. CAL OSHA, Title 8, Section 3291(f), Article 5. Window Cleaning (General Industry Safety Order, California Code of Regulations), Article 6, Powered Platforms for Exterior Building Maintenance, Article 23, Suspended Scaffolds (Construction), and Article 24, Fall Protection (construction).

F. Department of Labor Memorandum to Regional Administrators for Descent Control Devices.

8. American National Standards Institute

A. ANSI A39.1-1969 (Safety Requirements for Window Cleaning).

9. American Society of Mechanical Engineers

A. ASME A120.1-1996 (Safety Requirements for Powered Platforms for Building Maintenance).

B. ASME Addenda A120.1a-1997 and A120.1b-1999.

10. International Window Cleaner's Association

A. IWCA I-14-2001 (Window Cleaning Safety Standard).

11. American Society for Testing and Materials

A. ASTM D3963/D M-87 (Structural Specification for Epoxy Reinforcing Steel).

B. ASTM A36 (Non exposed Structural Components).

C. ASTM A123 (Standard Specification for Zinc Coating Hot Dip Galvanizing of Iron and Steel Products).

D. ASTM Z325 (Bolts, Nuts and Washers).

12. American Welding Society

A. AWS D1.1 (Structural Welding Code)

13. Aluminum Association

A. AA 5AS-30 (Specifications for Aluminum Structures)

1.04 SYSTEM DESCRIPTION

A. Design horizontal lifeline fall protection system to provide for safe execution of window washing or other suspended maintenance operations [including travel restraint].

B. Co-ordinate work of this Section with [Section 07500 - Membrane Roofing], to provide continuous waterproof protection.

C. Design anchors to resist without fracture a pull-out force of 5400 lbs (24.03 kN), applied in the most adverse direction.

1.05 SUBMITTALS

A. Manufacturer's descriptive literature for each product, including section or other type details.

B. Manufacturer's written installation instructions.

C. Shop drawings and samples, when required, in accordance with Section [01300]. Shop drawings to show roof layout indicating location and spacing of anchors and horizontal lifeline, including dimensions, detail drawings of securement to structure, design details, and similar data. Drawings to bear stamp of Professional Engineer licensed in the [Province] [State] in which the project is located.

D. Upon completion of project, provide Owner with Log Book for mandatory annual inspection.

E. Upon completion of project, provide Owner with roof plan showing layout of safety anchor system.

1.06 QUALITY ASSURANCE

A. Horizontal lifeline fall protection system manufacturer to have minimum 5 years documented experience in the design and fabrication of fall protection systems.

B. Comply with all requirements of:

1. [NBC (National Building Code of Canada)].

2. [OBC (Ontario Building Code)].

3. [ICBO (International Conference of Building Officials - Uniform Building Code)].

4. [BOCA (Building Officials Code Administrators - National Building Code)].

5. [SBBCI (Southern Building Code Congress International - Standard Building Code)].

1.06 SPECIAL WARRANTY

A. Warrant products installed under this section of work to be free of leaks, condensation and defects in materials and/or manufacture, as applicable, for a period of 20 years when installed in accordance with the manufacturer's written instructions.

PART 2: PRODUCTS

2.01 MANUFACTURER

A. Provide products as manufactured by Thaler Metal Industries, 1-800-387-7217 (Mississauga, Ontario, Canada) or 1-800-576-1200 (New Braunfels, TX) or provide equal products by another manufacturer approved in advance by the [Architect], based upon:

1. 20 year warranty against leaks, condensation and defects in materials and/or manufacture, as applicable;
2. structural rating for up to 12,000 lbf (53.28 kN) strength for anchors equipped with forged round eye;
3. structural integrity backed by \$7,000,000.00 liability insurance;
4. injection molded urethane insulation to CGSB-51-GP 46MP and ASTM C1029-90, as applicable;
5. air barrier flashing design using EPDM seals only complying with CSA B272-93 flashing standard;
6. maintenance free design;
7. materials and sizes options, and thickness;
8. treated flashing deck flange, as applicable;
9. written installation instructions.

2.02 MANUFACTURED UNITS

K-700 EASY SLIDER™ Horizontal Lifeline Fall Protection System (Roof Application)

A. Horizontal lifeline system (roof application): Thaler K-700 EASY SLIDER Horizontal Lifeline fall protection system to [CSA-Z91-02][OSHA 1910.66, Subparts D and F] with: 3-1/2" (89 mm) dia. urethane insulated HSS anchor posts, wall thickness 1/4" (6 mm), hot dipped galvanized ASTM 500, 12" (305 mm) high, welded and bolted to 1/2" x 8" x 8" (12 mm x 203 mm x 203 mm) 44W base plate, securement to suit substrate; Stainless steel fittings (swaged end, energy absorber, double locking carabiner, shuttles, end tensioner, intermediate brackets, corner pieces); Type 304 s.s. cable 3/8" (10 mm) dia. 7 x 19 structure; [2][4] full body harnesses with integral shock absorber (by others); [SJ-34, 7" (178 mm) high] [SJ-35 13" (330 mm) high] New-Standard STACK JACK Flashing of [.064" (1.6 mm) mill finish 1100-OT alloy aluminum] [.032" (0.831 mm) 24 oz. copper] [.031" (0.79 mm) 22 ga. Type 304 stainless steel] to CSA B272-93, with EPDM Triple Pressure Grommet Top Seal and EPDM Base Seal and [bituminous painted deck flange] [PVC coated deck flange].

K-701 EASY SLIDER™ Horizontal Lifeline Fall Protection System (Wall Application)

A. Horizontal lifeline system (wall application): Thaler K-701 EASY SLIDER Horizontal Lifeline fall protection system for walls to [CSA-Z91-02][OSHA 1910.66, Subparts D and F] with: stainless steel 3/8" (10 mm) brackets welded to stainless steel base plates 5/8" x 8" x 8" (16 mm x 203 mm x 203 mm), securement to suit substrate; stainless steel fittings (swaged end, energy absorber, double locking carabiner, shuttles, end tensioner, intermediate brackets, corner pieces); Type 304 s.s. cable, 3/8" (10 mm) dia. 7 x 19 structure; [2][4] fully body harnesses with integral shock absorber (by others).

K-702 EASY SLIDER™ Horizontal Lifeline Fall Protection System (Overhead Application)

A. Horizontal lifeline system (Overhead Application): Thaler K-702 EASY SLIDER Overhead Horizontal Lifeline fall protection system for overhead or similar applications to [CSA-02][OSHA 1910.66, Subparts D and F][OSHA 1926.500, Subpart M (Construction)] with: stainless steel 3/8" (10mm) brackets welded to stainless steel base plates 5/8" x 8" x 8" (16 mm x 203 mm x 203 mm), securement to suit substrate; stainless steel fittings (swaged end, energy absorber, double locking carabiner, end tensioner, shuttles, intermediate brackets, corner pieces); Type 304 s.s. cable, 3/8" (10 mm) dia. 7 x 19 structure; [2][4] fully body harnesses with integral shock absorber (by others).

K-703 EASY SLIDER™ Horizontal Lifeline Fall Protection System (Single Span Application)

A. Horizontal lifeline system (Single Span Application): Thaler K-703 EASY SLIDER Horizontal Lifeline fall protection system to [CSA-Z91-02][OSHA 1910.66, Subparts D and F] with: 3-1/2" (89 mm) dia. urethane insulated HSS anchor posts, wall thickness 1/4" (6 mm), hot dipped galvanized ASTM 500, 12" (305 mm) high, welded and bolted to 1/2" x 8" x 8" (12 mm x 203 mm x 203 mm) 44W base plate, securement to suit substrate; stainless steel fittings (swaged end, energy absorber, double locking carabiner, shuttles, end tensioner); Type 304 s.s. cable, 3/8" (10 mm) dia. 7 x 19 structure; [1][2] full body harnesses with integral shock absorber (by others); [SJ-34 (uninsulated) or SJ-37 (insulated), 7" (178 mm) high] [SJ-35 (uninsulated) or SJ-38 (insulated), 13" (330 mm) high] New-Standard STACK JACK Flashing of [.064" (1.6 mm) mill finish 1100-0T alloy aluminum] [.032" (0.831 mm) 24 oz. copper] [.031" (0.79 mm) 22 ga. Type 304 stainless steel] to CSA B272-93, with EPDM Triple Pressure Grommet Top Seal and EPDM Base Seal and [bituminous painted deck flange] [PVC coated deck flange].

PART 3: EXECUTION

3.01 EXAMINATION

A. Report to the Contractor in writing, defects of work prepared by other trades and other unsatisfactory site conditions. Verify site dimensions. Commencement of work will imply acceptance of prepared work.

Note: Review design criteria for tapered roof insulation systems if necessary for specific projects.

B. For roofs employing tapered insulation systems, height adjustments may be necessary i.e. ensure centre line of cable anchor bracket is minimum 9" (229 mm) above roof surface.

3.02 PREPARATION

Note: The following clauses apply to re-roofing or retrofit installations only.

A. For re-roofing or retrofit work, remove existing roof assembly as necessary to allow for installation of roof anchors.

B. In the event of structural deficiencies, deck corrosion or deterioration, ensure that a structural engineer has assessed and approved all surfaces upon which the work of this Section depends. Institute repairs and/or reinforcement where necessary.

C. If necessary, protect building interior and contents against ingress of water, dust, debris or other material.

D. Where possible and as directed by Roofing Consultant, reuse any salvageable materials and restore roofing system to match original.

3.03 INSTALLATION

Note: Delete clauses not applicable.

A. [Roof Anchors] [Wall Anchors] [Overhead Anchors]

1. Install anchors or equipment in accordance with manufacturer's printed instructions, shop drawings and as specified.

2. Ensure anchors or equipment is installed under the direct supervision of a Professional Engineer [and Roofing Consultant].

3. Where necessary, provide protection against deterioration due to contact of dissimilar materials.

4. Where bolting is used for fastening anchors, no fewer than two threads is to be exposed and the nut is to be positively locked by deforming threads, welding, pinning or equivalent method.

5. Ensure work is inspected prior to application of roofing.

B. Flashing

1. Install roof support flashing in accordance with manufacturer's printed instructions.

BUR

2. Set flashing deck flange in layer of plastic cement and flash in with 3 overlapping layers of felt flashing.

Modified Bitumen

3. Torch membrane until bitumen is fluid and set flashing deck flange into fluid. Flash in flange with two overlapping layers of ModBit and seal with asphalt sealer. Do not overheat (melt) EPDM Base Seal.

Single Ply

4. Set deck flange in layer of membrane adhesive and extend single ply up sleeve to highest elevation possible and clamp membrane to STACK JACK Flashing.

Note: For PVC membrane, specify PVC coated flashing; weld roofing to deck flange using PVC torch

PVC Single Ply

5. Set deck flange in layer of membrane adhesive and extend single ply up sleeve to highest elevation possible and clamp membrane to flashing. Weld roofing to deck flange using PVC torch.

6. Structural adequacy of [roof][wall][soffit] or other part of the building on which the support system is placed shall be verified by a professional engineer before installing horizontal lifeline.

3.04 FIELD QUALITY CONTROL

- A. Comply with the requirements of Section [01400 - Quality Control].

- B. All anchor work to be inspected by a qualified testing agency, Professional Engineer [and Roof Consultant] upon completion of work.

Note: Field testing of roof, wall or overhead anchor products is not required. Only the field testing of adhesive fasteners is required. In rare instances where adhesive fasteners must be tested after roof anchors have been roofed in, consult a Professional Engineer for calculation of the load requirement prior to testing.

3.05 ADJUSTING AND FINAL INSPECTION

- A. Verify that all manufactured units have been installed in accordance with specifications and details, and will function as intended. Adjust any items where necessary to ensure proper operation.

- B. Provide necessary documentation certifying system is acceptable for service (Engineer's Certificate of Acceptance).

3.06 CLEANING

- A. Clean manufactured units using materials and methods approved by manufacturer. Do not use cleaners or techniques which could impair performance of the roofing system.

End Of Section