

# Security Mortise Locks

h

1

REVISION  
APR 2005

## TABLE OF CONTENTS

Specifications/Standards of Excellence .....	2
Door Conditions .....	3
Ordering Instructions for Locks.....	4
<b>Lock Specifications</b>	
2.75" (70mm) Backset Locks – Knobs .....	5
2.75" (70mm) Backset Locks – Levers .....	5
Lock Functions .....	6–12
Electrified Locks .....	13–14
<b>Lock Specifications</b>	
2.5" (64mm) Backset Locks – Knobs .....	15
2.5" (64mm) Backset Locks – Levers .....	15
Lock Functions .....	16–18
2.5" (64mm) Backset Interior Mortise Locks – Knobs/Levers .....	19
<b>Lock Specifications</b>	
1.5" (38mm) and 2" (51mm) Backset Locks – Levers .....	21
Lock Functions .....	22–24
<b>Lock Components</b>	
Strikes .....	25–26
Armored Fronts.....	27–28
Complete Ordering Instructions .....	See Section I

# Mortise Locks—Specifications

- Most working parts are manufactured of solid forged brass material, precisely machined for maximum strength and smooth, lifetime operation. (Forgings have a 250% greater tensile strength than castings.)
- All lock cases are constructed of heavy gauge steel (.093–2.4mm - material) and plated with a protective rust-resistant coating to retard oxidation.
- Most lock functions are completely reversible in the field to facilitate installation.
- All locks and strikes are designed to fit standard preparation ANSI A115.1 (face cutouts are subject to variation). Locks have adjustable forged brass lock fronts, protected by armored scalp fronts for ultimate strength and protection against tampering.
- Please see ordering instructions and mortise lock/strike specification chart in this section for curved lip or extended lip strikes.
- All KEYED lock functions illustrated within this section are furnished with a specially-designed security strike constructed of high grade steel for ultimate strength and durability. The security strike is mortised into the wood jamb and anchored to the structural components of the opening with two 3" steel screws and covered with a finished strike to conceal the fasteners.
- Locks of 2.5" (64mm) and 2.75" (70mm) backsets are equipped with a 1" (25mm) throw deadbolt with two hardened steel inserts for maximum protection and security. All deadbolts are of forged brass construction. Locks designed with 1.5" (38mm) and 2" (51mm) backsets have a .5" (13mm) throw deadbolt.
- All 2.75" (70mm) and 2.5" (64mm) backset locks are furnished standard with an anti-friction latch bolt of .625" (16mm) throw and 1.25" (32mm) wide front.
- All 1.5" (38mm) and 2" (51mm) backset locks are furnished standard with a solid latch bolt of .5" (13mm) throw and 1" (25mm) wide front. An optional 1.25" (32mm) wide front is available. (Consult Price List for details.)
- All keys are designed with a 1.25" (32mm) wide bow surface to facilitate use by disabled and physically handicapped people.
- Our Design Department works closely with a number of America's most prestigious museums and historical foundations. Baldwin is renowned for meeting the stringent demands for quality and authenticity in the restoration-retrofit-rehabilitation markets.
- Numerous patents, copyrights, and trademarks are held by the Corporation to protect the integrity and reputation of our distinctive line of hardware appointments.

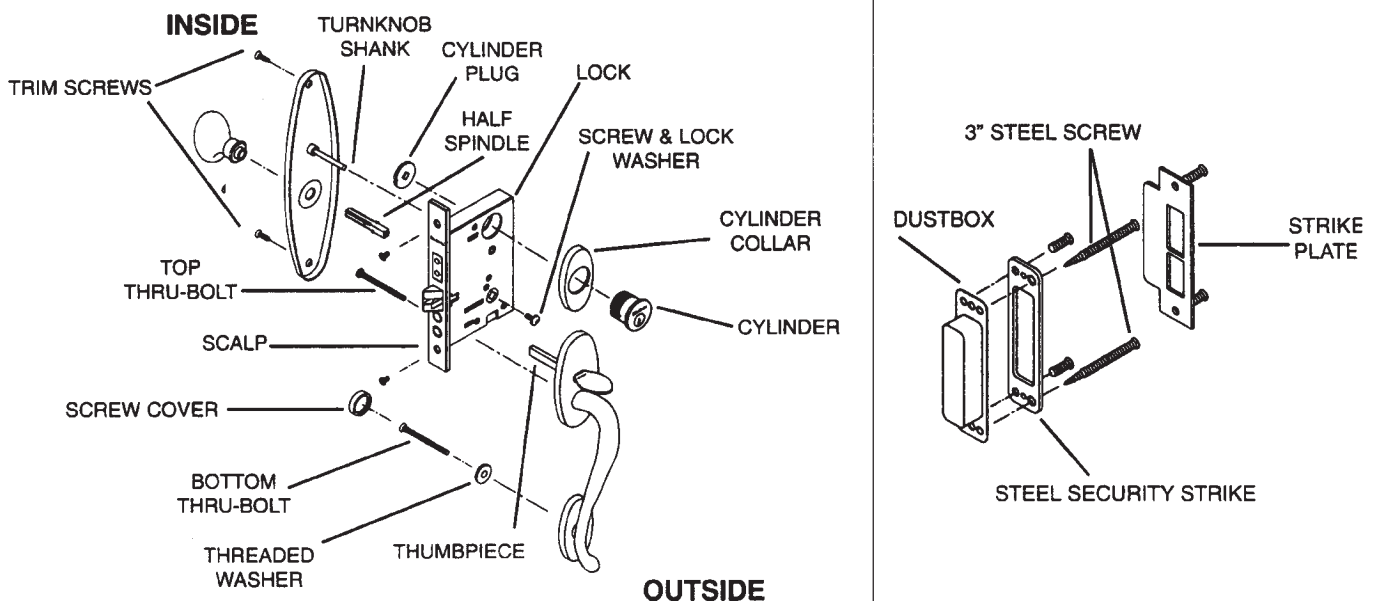

# Door Conditions

h

3

REVISION  
APR 2005

## RABBETED DOOR CONDITIONS

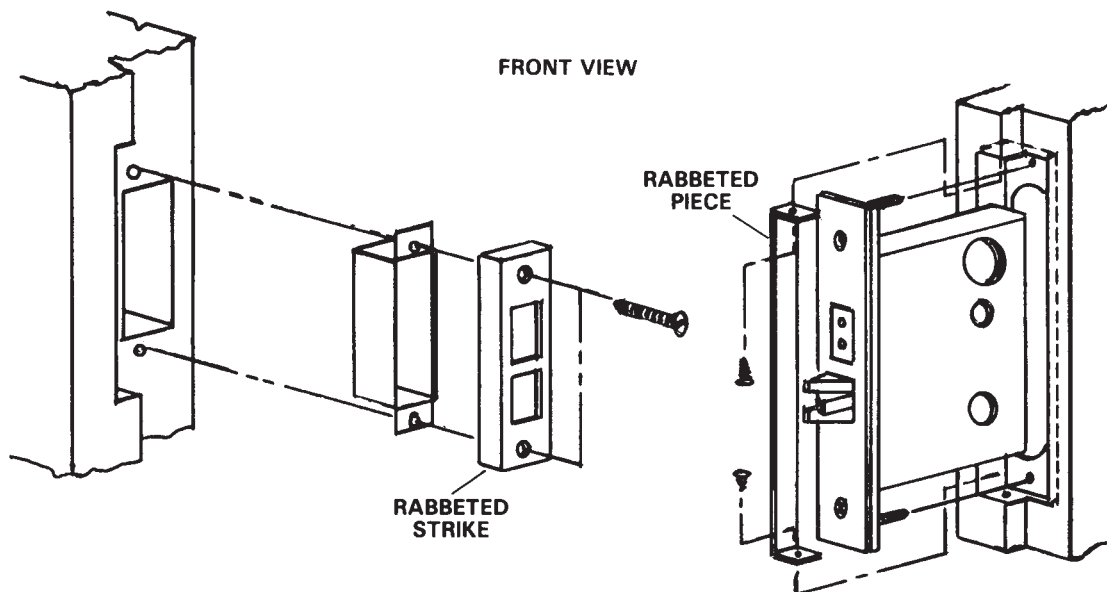

**No. 6897 — Used with all 1.5" (38mm), 2" (51mm), 2.5" (64mm) backset locks (6300, 6800 Series)**

**FEATURES:** Rabbeted strikes and pieces are used on pairs of doors that have a meeting rail which is rabbeted or on single doors that have a rabbeted frame. The strike is designed to fit in a .5" (13mm) rabbet; a separate rabbeted piece conforms to the face of the lock. This rabbeted assembly is available for locks with 1.25" (32mm) wide fronts only.

**SIZES:** Strike 1" × 5" (25 × 127mm) (Non-Handed); Rabbeted Piece: .5" × 8" (13 × 203mm)

**IMPORTANT NOTES:**

1. RABBETED STRIKE AND PIECE ARE ONLY AVAILABLE FOR 1.75" (44mm) DOORS.
2. When a rabbeted strike is ordered in conjunction with a keyed function lock, a steel security strike is NOT supplied.

**PACKED:** One complete set in a box with appropriate fasteners.

**ORDERING INSTRUCTIONS:** No. 6897 — Used with all 1.5" (38mm), 2" (51mm), 2.5" (64mm) backset locks (6300, 6800 Series). All locks which are furnished standard with a 1" (25mm) wide front must be ordered with a 1.25" (32mm) wide front. Consult price list for surcharge.

# Ordering Instructions

All Baldwin product numbers have a minimum of seven (7) digits. The first four (4) digits indicate the product, e.g. 6001 is a 2.75" backset, entrance function mortise lock. The next three (3) digits indicate the finish, e.g. 003 is PVD brass. Therefore, 6001.003 indicates a 2.75" backset, entrance function mortise lock in PVD finish.

In addition to the seven (7) base numbers, a suffix of from one (1) to four (4) digits or letters is sometimes used. These characters are placed to the right of the finish; e.g. 6001.003.RLS indicates a 2.75" backset, right hand entrance function mortise lock in PVD finish supplied with hub springs of sufficient strength to be used with levers.

## LOCK BACKSET COMPARISON CHART

TRIM SYMBOL	DESCRIPTION	2.75" BACKSET (Handle Sets, Knobs & Levers)	2.5" BACKSET (Handle Sets, Knobs & Levers)	2" BACKSET (Levers)	1.5" BACKSET (Levers)
ENTR	ENTRANCE FUNCTION	6001, 6010, 6020, 6021, 6070, 6075, 6077, 6091	6301, 6310, 6320, 6321, 6375	6802, 6812, 6832	6800, 6810, 6830
SGLC	SINGLE CYLINDER FUNCTION	6051, 6053, 6060, 6065, 6066, 6130	—	—	—
EXTR	EXTERIOR PATIO FUNCTION	6055, 6100	6315	6847	6845
PRIV	PRIVACY FUNCTION	6055, 6100	6315	6847	6845
PASS	PASSAGE FUNCTION	6110	6318	6857	6855
DM	DUMMY TRIM - ONE SIDE OF DOOR	—	—	—	—
FD	FULL DUMMY TRIM	—	—	—	—
HOTL	HOTEL FUNCTION	6091	—	—	—
BB75	BACK TO BACK HANDLE SETS	6025, 6030	6325	—	—

**NOTE: ENTRANCE FUNCTION LOCKS MAY BE USED IN EITHER SINGLE CYLINDER OR DOUBLE CYLINDER APPLICATIONS.**

**TO ORDER:** 2.75"/2.5" BACKSET LOCKS FOR LEVERS, SPECIFY LS (LEVER STRENGTH) AFTER LOCK NUMBER (i.e. 6375.030.RLS LOCK - RH).

**NOTE:** 1.5" and 2.0" Backset Locks are designed to be used with levers. If knobs are specified, customer should be advised that the knob will only turn in one direction and will have a stiff turning action: NOT RECOMMENDED.

**CURVED LIP STRIKES:** Locks may be ordered with curved lip strikes. The hand of strike will match the hand of the door. Please specify hand of door when ordering. A left hand reverse door will use a right hand strike and a right hand reverse door will use a left hand strike.

## DOOR CONDITIONS

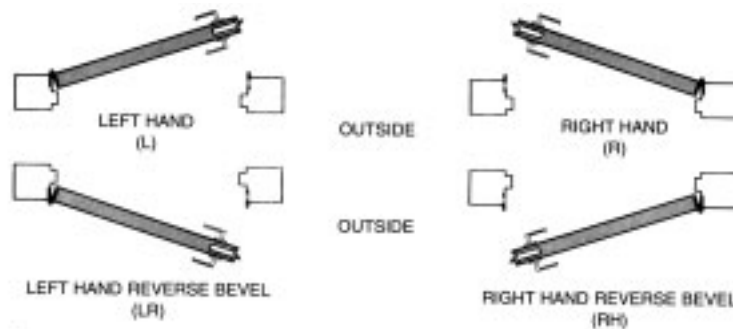

## HAND OF DOOR IS ALWAYS DETERMINED FROM THE OUTSIDE

Here are a few rules to follow:

- The outside of an exterior door is the street or entrance side.
- The outside of a room door is the hall side.
- The outside of a single communicating door is the side from which the hinges are not visible when the door is closed.
- The outside of a closet door is the room or hall side.

**FOR ADDITIONAL INFORMATION, REFER TO SECTION I ORDERING INSTRUCTIONS.**

# 2.75" (70mm) Backset Mortise Locks Lock Specifications

## HEAVY DUTY MORTISE LOCKS FOR DOORS 1.75" (44mm) THICK AND OVER

**LOCK SPECIFICATIONS:** Standardized heavy steel case is smooth, easy to mortise, and assures snug and solid fit in door mortise. Vital interior working parts are made of solid hot forged brass or steel for a lifetime of trouble-free operation. Armored front provides maximum strength and protection against tampering. Most lock functions are completely reversible. The bevel of front is adjustable from flat to standard bevel .125" on 2" (3mm on 51mm). Most metal door and frame manufacturers have provided reinforcements for Baldwin Mortise Locks.

**STEEL CASE:** .875" x 4" x 5.5" (22 x 102 x 140mm)

**FRONT:** Hot forged brass .218" x 1.25" x 8" (6 x 32 x 203mm). Adjustable for beveled conditions.

**SCALP:** Wrought brass and bronze, available in standard finishes.

**ANTI-FRICTION LATCH BOLT:** Hot forged brass .625" x 1" (16 x 25mm) x .75" (19mm) throw. Furnished in US4 and 26D finishes to match trim. Solid latch bolt is available and when ordered, is furnished with a curved lip strike.

**DEAD BOLT:** .5" x 1.25" (13 x 32mm) x 1" (25mm) throw with two saw-proof inserts. Furnished in US4 and 26D finishes to match trim.

**HUB SIZE:** .29" (7mm) with two-way rotation. Broached on the diamond. (One-way rotation on LS functions).

**BACKSET:** 2.75" (70mm)

**SPACING:** center to center of:  
Knob Hub to cylinder 3.437" (87mm)  
Knob Hub to turn piece 2.25" (57mm)

**CYLINDER:** Standard mortise type with 03 keyway and two nickel silver keys. Cylinder is not supplied with lock.

**KEYING:** All levels of Keying including Construction Keying are available. For additional information, refer to Section K.

**STRIKE:** Wrought brass and bronze finished to match. Supplied to ANSI standard A115.1, 1.25" (32mm) lip to center. Locks furnished standard with straight lip strike (Universal) and dust box. Curved lip and special length strikes available. All KEYED lock functions are furnished standard with a high grade **steel security strike** and two 3" steel screws.

**TEMPLATE:** Metal doors/frames to be prepared in accordance with ANSI A115.1 or A115.11. FACE CUTOUTS ARE SUBJECT TO VARIATION. ALWAYS REVIEW TRIM REQUIREMENTS BEFORE DOOR PREPARATION.

**SPINDLE SYMBOLS:**

		Swivel Spindle
		Solid Spindle
		Half Spindle

**ORDERING INSTRUCTIONS:**

**Knob Functions:** Specify appropriate lock number

**Lever Functions:** Specify lock number with symbol LS (Lever Strength)

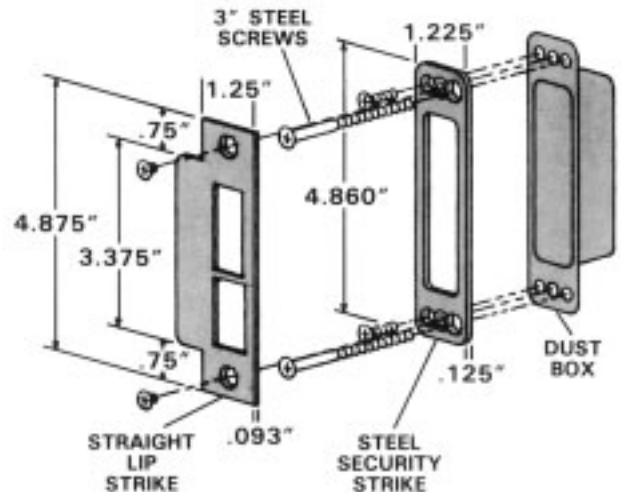
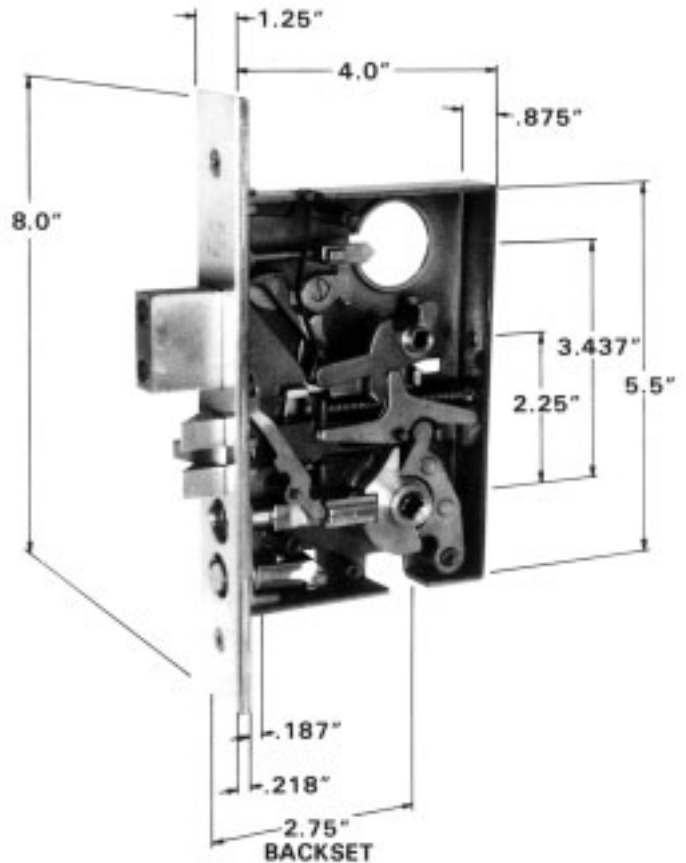

## 2.75" (70mm) Backset Mortise Locks Heavy Duty Functions

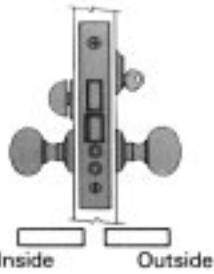

No. 6001 Knob Function  
No. 6001-LS Lever Function

### ENTRANCE AND APARTMENT

Latch bolt by knob from either side, except when outside knob is locked by stop in front; then latch bolt by key outside and knob inside. Dead bolt by key outside and turn piece inside. Continuous turn of key outside retracts both latch and dead bolt.

1" (25mm) throw dead bolt with saw-proof inserts is standard equipment. When extended, dead bolt deadlocks latch bolt.

**WEIGHT:** 3 lbs. (1.36kg)

**FEDERAL SPECIFICATION EQUIVALENTS:** ANSI Series: 1000-F08/F10

**NOTE:** FOR SINGLE AND DOUBLE CYLINDER APPLICATIONS.

#### STANDARD FEATURES



SAW-PROOF  
INSERTS  
1" THROW



SECURITY  
STRIKE

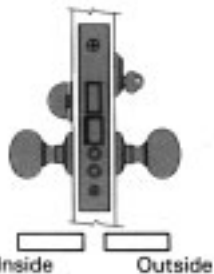

No. 6075 Knob Function  
No. 6075-LS Lever Function

### ENTRANCE—EMERGENCY EGRESS

Latch bolt by knob from either side, except when outside knob is locked by stop in front; then latch bolt by key outside and knob inside. Dead bolt by key outside and turn piece inside. When dead bolt is thrown, stop is automatically activated making outside knob rigid. Inside knob retracts latch and dead bolt simultaneously but DOES NOT free outside knob.

1" (25mm) throw dead bolt with saw-proof inserts is standard equipment. When extended, dead bolt deadlocks latch bolt.

**WEIGHT:** 3 lbs. (1.36kg)

**FEDERAL SPECIFICATION EQUIVALENTS:** ANSI Series: 1000-F12/F20

**NOTE:** NOT RECOMMENDED FOR DOUBLE CYLINDER APPLICATIONS.

#### STANDARD FEATURES



SAW-PROOF  
INSERTS  
1" THROW



SECURITY  
STRIKE

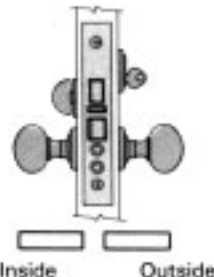

No. 6077 Knob Function  
No. 6077-LS Lever Function

### ENTRANCE—EMERGENCY EGRESS

Latch bolt by knob from either side, except when outside knob is locked by stop in front; then latch bolt by key outside and knob inside. Dead bolt by key outside and turn piece inside. When dead bolt is thrown, stop is automatically activated making outside knob rigid. Inside knob retracts latch and dead bolt simultaneously but DOES NOT free outside knob.

1" (25mm) throw dead bolt with saw-proof inserts is standard equipment. When extended, dead bolt deadlocks latch bolt. Auxiliary latch bolt deadlocks latch bolt, creating a DOUBLE DEADLOCKING FEATURE when the dead bolt is extended.

**WEIGHT:** 3 lbs. (1.36kg)

**FEDERAL SPECIFICATION EQUIVALENTS:** ANSI Series: 1000-F20

**NOTE:** NOT FIELD REVERSIBLE.

NOT RECOMMENDED FOR DOUBLE CYLINDER APPLICATIONS.

#### STANDARD FEATURES



SAW-PROOF  
INSERTS  
1" THROW



SECURITY  
STRIKE

# 2.75" (70mm) Backset Mortise Locks Heavy Duty Functions

## STANDARD FEATURES



## ENTRANCE AND STOREROOM

Latch bolt by knob either side. Deadbolt by key outside and turn piece inside.

1" (25mm) throw dead bolt with saw-proof inserts is standard equipment. When extended, dead bolt deadlocks latch bolt.

**WEIGHT:** 3 lbs. (1.36kg)

**FEDERAL SPECIFICATION EQUIVALENTS:** ANSI Series: 1000-F21

**NOTE:** FOR SINGLE AND DOUBLE CYLINDER APPLICATIONS.

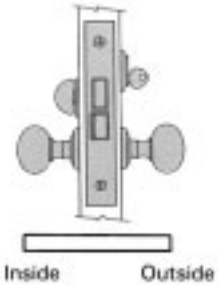

**No. 6010 Knob Function**  
**No. 6010-LS Lever Function**

## STANDARD FEATURES



## HOTEL

Latch bolt by knob inside and key outside. Outside knob is always rigid. Deadbolt by turn piece inside which shuts out all keys except emergency and display keys. Inside knob retracts latch bolt and deadbolt simultaneously.

Auxiliary latch deadlocks latch bolt.

1" (25mm) throw deadbolt with saw-proof inserts is standard equipment.

Furnished standard with a 1.25" (32mm) wide key bow and 6 pin cylinder. Hotel key bow is available at an additional charge. Consult price list.

**WEIGHT:** 3 lbs. (1.36kg)

**NOTE:** NOT FIELD REVERSIBLE.

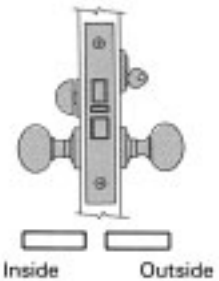

**No. 6091 Knob Function**  
**No. 6091-LS Lever Function**

## STANDARD FEATURES



## ENTRANCE—EMERGENCY EGRESS

Latch bolt by knob from either side, except when outside knob is locked by stop in front. When outside knob is locked, the latch bolt and dead bolt are retracted by key outside and knob inside. Dead bolt by key either side. When extended, dead bolt automatically locks outside knob. Inside knob retracts latch and dead bolt simultaneously but DOES NOT free outside knob. When extended, dead bolt deadlocks latch bolt. 1" (25mm) throw dead bolt with saw-proof inserts is standard equipment.

Auxiliary latch bolt deadlocks latch bolt, creating a DOUBLE DEADLOCKING FEATURE when the dead bolt is extended.

**IMPORTANT:** This lock function is specially developed for use on exterior doors on commercial projects. The stops cannot be activated unless a key is used to engage/disengage the stop mechanisms. This feature prohibits an unauthorized individual from locking or unlocking the door. When the deadbolt is thrown, both the dead bolt and auxiliary latch bolt guard the latch bolt from being retracted. Designed expressly for buildings where security guards strictly control the access to/from the building. Each cylinder can be master keyed differently to meet specific keying requirements.

**WEIGHT:** 3.3 lbs. (1.50kg)

**NOTE:** NOT FIELD REVERSIBLE.

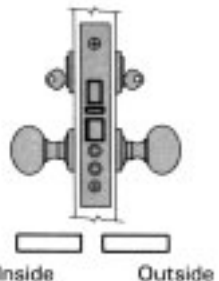

**No. 6080 Knob Function**  
**No. 6080-LS Lever Function**

## 2.75" (70mm) Backset Mortise Locks Heavy Duty Functions

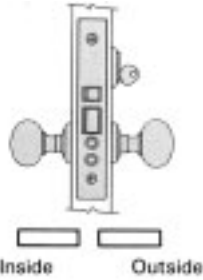

No. 6060 Knob Function  
No. 6060-LS Lever Function

### CORRIDOR AND OFFICE

Latch bolt by knob from either side, except when outside knob is locked by stop in front, then by key outside and knob inside.

Auxiliary latch deadlocks latch bolt.

**WEIGHT:** 2.8 lbs. (1.27kg)

**FEDERAL SPECIFICATION EQUIVALENTS:** ANSI Series: 1000-F04

#### STANDARD FEATURES

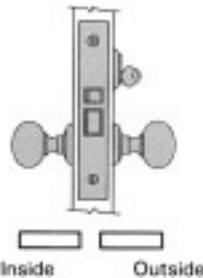

No. 6130 Knob Function  
No. 6130-LS Lever Function

### CLASSROOM

Latch bolt by knob either side, except when outside knob is locked by key outside, then by key outside. Inside knob is always free.

Auxiliary latch deadlocks latch bolt.

**WEIGHT:** 2.8 lbs. (1.27kg)

**FEDERAL SPECIFICATION EQUIVALENTS:** ANSI Series: 1000-F05

#### STANDARD FEATURES

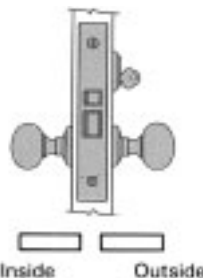

No. 6065\* Knob Function  
No. 6065-LS\* Lever Function

### EMERGENCY AND UTILITY ROOM

Auxiliary latch deadlocks latch bolt.

\*Suggested for use with electric strike. Caution should be used to ensure that the electric strike being used properly engages the latch mechanism while depressing the auxiliary latch. We recommend solid latch bolt with this lock when used with an electric strike.

**WEIGHT:** 2.8 lbs. (1.27kg)

**FEDERAL SPECIFICATION EQUIVALENTS:** ANSI Series: 1000-F07

**NOTE:** For handle set applications, refer to Function No. 6066.

#### STANDARD FEATURES

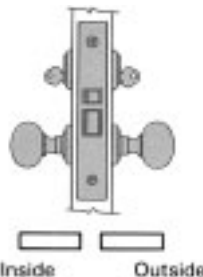

No. 6085 Knob Function  
No. 6085-LS Lever Function

### APARTMENT ENTRANCE

Latch bolt by knob either side, except when outside knob is locked by key from inside. When outside knob is locked, latch bolt by tenant key outside and knob inside.

Auxiliary latch deadlocks latch bolt.

When specified, inside cylinder shall operate by master key only.

**WEIGHT:** 3 lbs. (1.36kg)

**FEDERAL SPECIFICATION EQUIVALENTS:** ANSI Series: 1000-F09

**NOTE:** LOCK FUNCTION IS NOT REVERSIBLE – SPECIFY HAND.

#### STANDARD FEATURES





# 2.75" (70mm) Backset Mortise Locks Heavy Duty Functions

**h**  
**9**  
REVISION  
APR 2005

## STANDARD FEATURES



## DORMITORY AND EXIT

Latch bolt by knob either side. Dead bolt by key outside and turn piece inside. When dead bolt is projected, latch bolt is deadlocked and outside knob is rigid. Inside knob retracts latch and dead bolt simultaneously, automatically unlocking outside knob.

1" (25mm) throw dead bolt with saw-proof inserts is standard equipment. When extended, dead bolt deadlocks latch bolt.

**WEIGHT:** 3 lbs. (1.36kg)

**FEDERAL SPECIFICATION EQUIVALENTS:** ANSI Series: 1000-F13

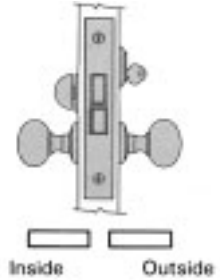

**No. 6070 Knob Function**  
**No. 6070-LS Lever Function**

## PASSAGE

Latch bolt by knob either side.

**WEIGHT:** 2.6 lbs. (1.18kg)

**FEDERAL SPECIFICATION EQUIVALENTS:** ANSI Series: 1000-F01

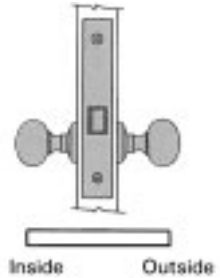

**No. 6110 Knob Function**  
**No. 6110-LS Lever Function**

## STANDARD FEATURES



## BATHROOM AND BEDROOM

Latch bolt by knob either side. Dead bolt by turn piece inside and emergency key No. 0417 outside.

1" (25mm) throw dead bolt with saw-proof inserts is standard equipment. When extended, dead bolt deadlocks latch bolt.

**WEIGHT:** 2.8 lbs. (1.27kg)

**FEDERAL SPECIFICATION EQUIVALENTS:** ANSI Series: 1000-F02

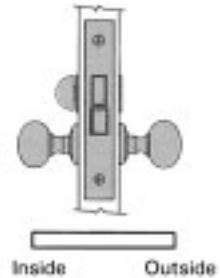

**No. 6100 Knob Function**  
**No. 6100-LS Lever Function**

## STANDARD FEATURES



## PRIVACY

Latch bolt by knob either side. Dead bolt by turn piece inside and emergency key No. 0417 outside. Inside knob retracts latch and dead bolt simultaneously, automatically unlocking outside knob.

1" (25mm) throw dead bolt with saw-proof inserts is standard equipment. When extended, dead bolt deadlocks latch bolt.

**WEIGHT:** 2.8 lbs. (1.27kg)

**FEDERAL SPECIFICATION EQUIVALENTS:** ANSI Series: 1000-F19

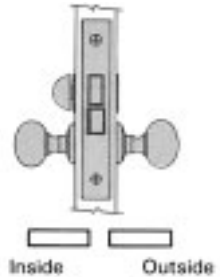

**No. 6055 Knob Function**  
**No. 6055-LS Lever Function**

TRIM SHOWN FOR ILLUSTRATION PURPOSES ONLY. SPECIFY LOCK NUMBER, FINISH, HAND, DOOR THICKNESS, AND TRIM DESIGN.

## 2.75" (70mm) Backset Dead Locks Heavy Duty Functions



No. 6150

### SINGLE CYLINDER

Dead bolt by cylinder key one side only. Furnished standard with No. 8300 Cylinder Collar.

Optional 1" Front available at an additional cost.

**WEIGHT:** 2 lbs. (.91kg)

**FEDERAL SPECIFICATION EQUIVALENTS:** ANSI Series: 1000-F18

**NOTE:** MAY BE USED IN DOUBLE CYLINDER APPLICATIONS.

#### STANDARD FEATURES



No. 6160

### TURN PIECE/CYLINDER

Dead bolt by cylinder key outside and turn piece inside. Furnished standard with No. 8300 Cylinder Collar and No. 6750 Turn Piece. Other turn pieces are available as illustrated in Section H at appropriate substitution of price.

Optional 1" Front available at an additional cost.

**WEIGHT:** 2.3 lbs. (1.04kg)

**FEDERAL SPECIFICATION EQUIVALENTS:** ANSI Series: 1000-F17

#### STANDARD FEATURES



# 2.75" (70mm) Backset Mortise Locks Heavy Duty Functions

## STANDARD FEATURES



## RESIDENTIAL ENTRANCE

Latch bolt by thumb piece outside and knob inside, except when thumb piece is locked by stop in front; then latch bolt by key outside and knob inside. Dead bolt by key outside and turn piece inside. Continuous turn of key outside retracts both latch and dead bolt.

1" (25mm) throw dead bolt with saw-proof inserts is standard equipment. When extended, dead bolt deadlocks latch bolt.

**WEIGHT:** 3 lbs. (1.36 kg)

**FEDERAL SPECIFICATION EQUIVALENT:** Government Type: 122A

**NOTE:** MAY BE USED IN SINGLE AND DOUBLE CYLINDER APPLICATIONS.



**No. 6020 Knob Function**  
**No. 6020-LS Lever Function**

## STANDARD FEATURES



## RESIDENTIAL ENTRANCE — EMERGENCY EGRESS

Latch bolt by thumb piece outside and knob inside, except when thumb piece is locked by stop in front; then latch bolt by key outside and knob inside. Dead bolt by key outside and turn piece inside. When dead bolt is thrown, stop is automatically activated making outside thumb piece rigid. Inside knob retracts latch and dead bolt simultaneously but DOES NOT free outside thumb piece.

1" (25mm) throw dead bolt with saw-proof inserts is standard equipment. When extended, dead bolt deadlocks latch bolt.

**WEIGHT:** 3 lbs. (1.36kg)

**NOTE:** NOT RECOMMENDED FOR DOUBLE CYLINDER APPLICATIONS.



**No. 6021 Knob Function**  
**No. 6021-LS Lever Function**

## 2.75" (70mm) Backset Mortise Locks Heavy Duty Functions

### BACK-TO-BACK ENTRANCE



No. 6025

Latch bolt by thumb piece from either side, except when outside thumb piece is locked by stop in front, then latch bolt by key either side and thumb piece inside. Dead bolt by key either side, continuous turn of key retracts both latch and dead bolt.

1" (25mm) throw dead bolt with saw-proof inserts is standard equipment. When extended, dead bolt deadlocks latch bolt.

**WEIGHT:** 3.3 lbs. (1.50kg)

**NOTE:** To order and price complete trim sets, order two sets of exterior handle trim in "BBXX" configuration. Baldwin turnpiece cylinder 844X.XXX may be used for interior.

#### STANDARD FEATURES



### PUBLIC ENTRANCE



No. 6030

Latch bolt by thumb piece either side. Dead bolt by key either side.

1" (25mm) throw dead bolt with saw-proof inserts is standard equipment. When extended, dead bolt deadlocks latch bolt.

**WEIGHT:** 3.3 lbs. (1.50 kg)

**FEDERAL SPECIFICATION EQUIVALENTS:** ANSI Series: 1000-F25

**NOTE:** To order and price complete trim sets, order two sets of exterior handle trim.

#### STANDARD FEATURES



### ELECTRIC STRIKE ENTRANCE



No. 6066 Knob Function  
No. 6066-LS Lever Function

Latch bolt by knob inside and key outside. Outside trim is always rigid.

Auxiliary latch deadlocks latch bolt.

Optional solid latch bolt is available with this lock.

Caution should be used to ensure that the electric strike being used properly engages the latch mechanism while depressing the auxiliary latch.

**WEIGHT:** 2.8 lbs. (1.27kg)

#### STANDARD FEATURES



# 2.75" (70mm) Backset Electrified Mortise Locks Lock Specifications

h  
13  
REVISION  
APR 2005

## 2.75" (70mm) BACKSET MORTISE LOCKS FOR DOORS 1.75" (44mm) THICK AND OVER

**LOCK SPECIFICATIONS:** Standardized heavy steel case is smooth, easy to mortise, and assures snug and solid fit in door mortise. Vital interior working parts are made of solid hot forged brass or steel for a lifetime of trouble-free operation. Armored front provides maximum strength and protection against tampering. Most lock functions are completely reversible. The bevel of front is adjustable from flat to standard bevel .125" on 2" (3mm on 51mm). Most metal door and frame manufacturers have provided reinforcements for Baldwin Mortise Locks.

**CONSTRUCTION:** Refer to page H/5 of this catalog section.

**FRONT:** Hot forged brass .218" x 1.25" x 8" (6 x 32 x 203mm). Adjustable for beveled conditions.

**BACKSET:** 2.75" (70mm)

**KEYING:** All levels of Keying including Construction Keying are available. For additional information, refer to section K.

**STRIKE:** Wrought brass and bronze finished to match. Supplied to ANSI standard A115.1, 1.25" (32mm) lip to center. Locks furnished standard with straight lip strike (Universal) and dust box. Curved lip and special length strikes available. All KEYED lock functions are furnished standard with a high grade **steel security strike** and two 3" steel screws.

**TEMPLATE:** Metal doors/frames to be prepared in accordance with ANSI A115.1 or A115.11. FACE CUTOUPS ARE SUBJECT TO VARIATION. ALWAYS REVIEW TRIM REQUIREMENTS BEFORE DOOR PREPARATION.

**DOOR THICKNESS:** 1.75" (44mm) thick is standard. For other door thicknesses, specify size.

**ELECTRICAL SPECIFICATIONS:**

**RATED VOLTAGE:** 24V AC/24V DC – AC/DC Converter is built inside.

**OPERATING VOLTAGE RANGE:** 22-26V AC/V DC

**TEST VOLTAGE:** 18V AC/V DC

**RATED CURRENT:** 0.35 Amperes (0.4 Amperes Maximum)

**DUTY:** Continuous

**SOLENOID LEAD WIRE LENGTH:** 6" (153mm)

**IMPORTANT FEATURE:** To facilitate installation, Solenoid is constructed inside the lock case.

**IMPORTANT NOTES:**

1. Each electrified lock should have its own 24 volt transformer. Two or more locks may be operated in PARALLEL from a single transformer with the proper current rating. DO NOT connect locks in a series from a higher rated transformer.
2. We DO NOT recommend wiring electrified locks to a circuit containing electromagnetic devices as transient voltage can cause damage to the lock. Transient voltage must be suppressed at its source before connecting locks to the circuit.
3. A Varistor at 35 volts (peak-recurrent) may be used for transient voltage protection.

**ORDERING INSTRUCTIONS:**

**Knob Functions:** Specify appropriate lock number

**Lever Functions:** Specify lock number with symbol  
LS (Lever Strength)

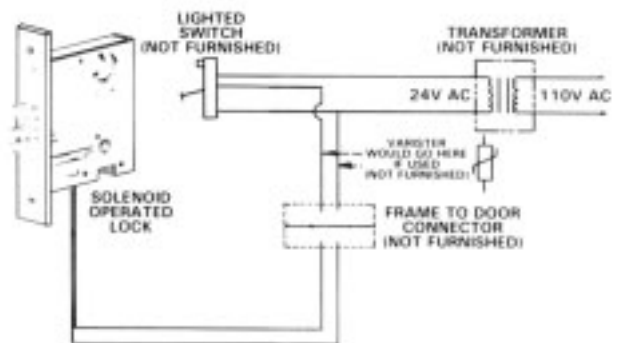
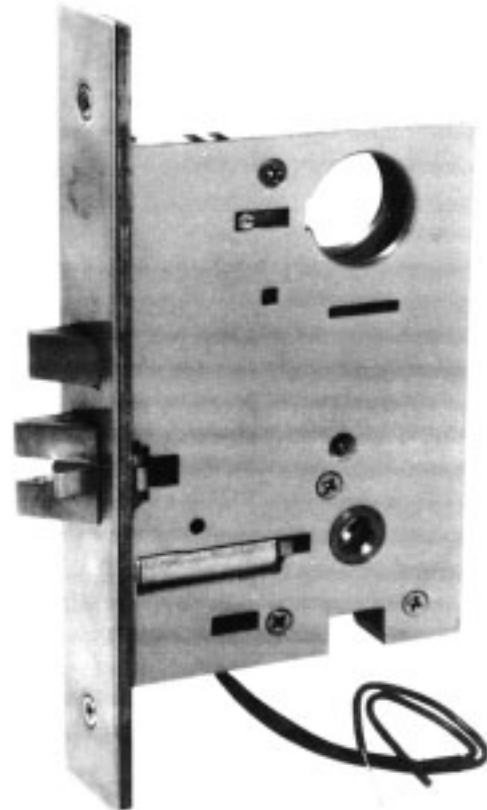

## 2.75" (70mm) Backset Mortise Locks Electrified Lock Functions

### FAIL SAFE

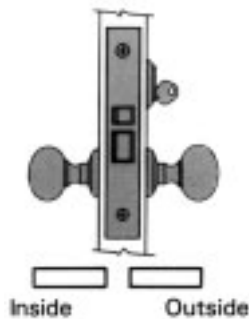

No. 6051 Knob Function  
No. 6051-LS Lever Function



- Latch bolt by knob either side except when outside knob is locked by energizing solenoid.
- Key outside retracts latch bolt when solenoid is energized.
- Inside knob is always FREE.
- Auxiliary Latch deadlocks latch bolt.

**IMPORTANT:** POWER OFF UNLOCKS OUTSIDE KNOB.

### FAIL SECURE

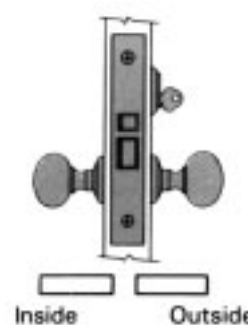

No. 6053 Knob Function  
No. 6053-LS Lever Function



- Latch bolt by knob either side ONLY when solenoid is energized.
- Latch bolt retracted by key outside and knob inside when solenoid is NOT energized.
- Inside knob is always FREE.
- Auxiliary Latch deadlocks latch bolt.

**IMPORTANT:** POWER OFF LOCKS OUTSIDE KNOB.

**APPLICATIONS:** Electrically-controlled locking devices are designed for specific security and fire safety installations including:

- Security Controlled Entrances
- Apartment Buildings
- Remote-controlled Security Doors
- Fire Safety Alarms
- Stairwell Doors
- Computer Rooms
- Hospital/Narcotic Areas
- Cashier Rooms

**CONTROLLING/REGULATING DEVICES:** Electrified locks can be locked or unlocked by the following means:

- Toggle (Wall) Switch
- Master Control Consoles
- Automatic Time Devices
- Security Alarms
- Computerized Controls
- Access Card Readers
- Smoke/Fire Alarms
- Thermo-Sensitive Devices

# 2.5" (64mm) Backset Mortise Locks Lock Specifications

h

15

REVISION  
APR 2005

## HEAVY DUTY MORTISE LOCKS FOR DOORS 1.375" (35mm) / 1.75" (44mm) THICK AND OVER

**LOCK SPECIFICATIONS:** Standardized heavy steel case is smooth, easy to mortise, and assures snug and solid fit in door mortise. Vital interior working parts are made of solid hot forged brass or steel for a lifetime of trouble-free operation. Armored front provides maximum strength and protection against tampering. Most lock functions are completely reversible. The bevel of front is adjustable from flat to standard bevel .125" on 2" (3mm on 51mm). Most metal door and frame manufacturers have provided reinforcements for Baldwin Mortise Locks.

**STEEL CASE:** .75" x 3.5" x 5.5" (19 x 89 x 140mm)

**FRONT\*:** Hot forged brass .218" x 1.25" x 8" (6 x 32 x 203mm). Adjustable for beveled conditions.

\*Optional 1" (25mm) front with .75" (19mm) solid latch bolt available for doors of 1.375" (35mm) in thickness. Furnished standard with a curved lip strike.

**SCALP:** Wrought brass and bronze, available in standard finishes.

**ANTI-FRICTION LATCH BOLT:** Hot forged brass .5" x 1" (13 x 25mm) x .75" (19mm) throw. Furnished in US4 and 26D finishes to match trim.

**DEAD BOLT:** .5" x 1.25" (13 x 32mm) x 1" (25mm) throw with two saw-proof inserts. Furnished in US4 and 26D finishes to match trim.

**HUB SIZE:** .29" (7mm) with two-way rotation. Broached on the diamond. (One-way rotation on LS functions.)

**BACKSET:** 2.5" (64mm)

**SPACING:** center to center of:  
Knob Hub to cylinder 3.437" (87mm)  
Knob Hub to turn piece 2.25" (57mm)

**CYLINDER:** Standard mortise type with 03 keyway and two nickel silver keys. Cylinder is not supplied with lock.

**KEYING:** All levels of Keying including Construction Keying are available. For additional information, refer to Section K.

**STRIKE:** Wrought brass and bronze finished to match. Supplied to ANSI standard A115.1, 1.25" (32mm) lip to center. Locks furnished standard with straight lip strike (Universal) and dust box. Curved lip and special length strikes available. All KEYED lock functions are furnished standard with a high grade **steel security strike** and two 3" steel screws.

**TEMPLATE:** Metal doors/frames to be prepared in accordance with ANSI A115.1 or A115.11. FACE CUTOUTS ARE SUBJECT TO VARIATION. ALWAYS REVIEW TRIM REQUIREMENTS BEFORE DOOR PREPARATION.

**SPINDLE SYMBOLS:**

	Swivel Spindle
	Solid Spindle
	Half Spindle

**ORDERING INSTRUCTIONS:**

**Knob Functions:** Specify appropriate lock number

**Lever Functions:** Specify lock number with symbol LS (Lever Strength)

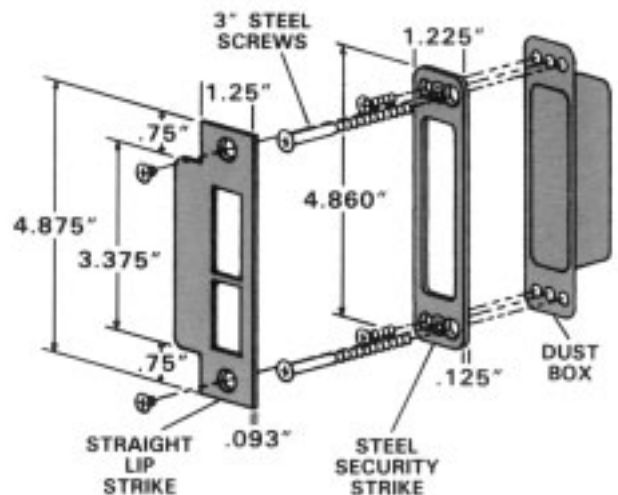
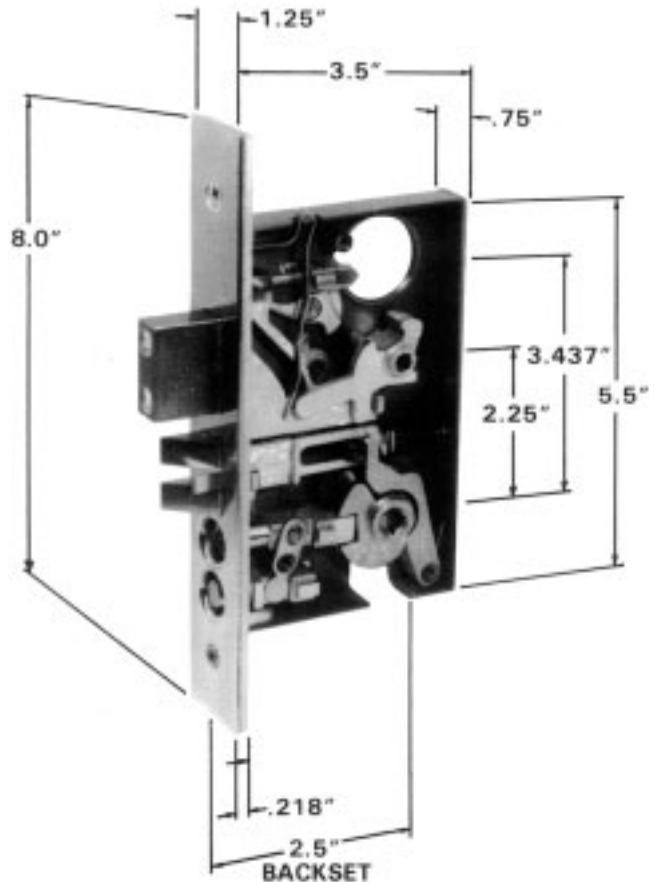

## 2.5" (64mm) Backset Mortise Locks Heavy Duty Functions

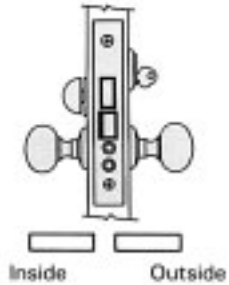

No. 6301 Knob Function  
No. 6301-LS Lever Function

### ENTRANCE AND APARTMENT

Latch bolt by knob from either side, except when outside knob is locked by stop in front; then latch bolt by key outside and knob inside. Dead bolt by key outside and turn piece inside. Continuous turn of key outside retracts both latch and dead bolt.

1" (25mm) throw dead bolt with saw-proof inserts is standard equipment. When extended, dead bolt deadlocks latch bolt.

**WEIGHT:** 3 lbs. (1.36kg)

**NOTE:** MAY BE USED IN SINGLE AND DOUBLE CYLINDER APPLICATIONS.

#### STANDARD FEATURES

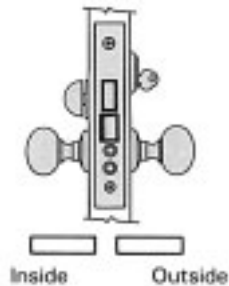

No. 6375 Knob Function  
No. 6375-LS Lever Function

### RESIDENTIAL ENTRANCE— EMERGENCY EGRESS

Latch bolt by knob from either side, except when outside knob is locked by stop in front; then latch bolt by key outside and knob inside. Dead bolt by key outside and turn piece inside. When dead bolt is thrown, stop is automatically activated making outside knob rigid. Inside knob retracts latch and dead bolt simultaneously but DOES NOT free outside knob.

1" (25mm) throw dead bolt with saw-proof inserts is standard equipment. When extended, dead bolt deadlocks latch bolt.

**WEIGHT:** 3 lbs. (1.36kg)

**NOTE:** LOCK FUNCTION IS NOT REVERSIBLE — SPECIFY HAND. NOT RECOMMENDED FOR DOUBLE CYLINDER APPLICATIONS.

#### STANDARD FEATURES

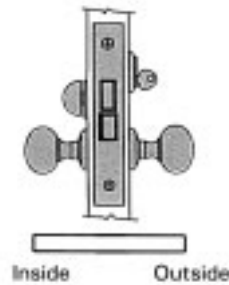

No. 6310 Knob Function  
No. 6310-LS Lever Function

### ENTRANCE AND STOREROOM

Latch bolt by knob from either side. Dead bolt by key outside and turn piece inside.

1" (25mm) throw dead bolt with saw-proof inserts is standard equipment. When extended, dead bolt deadlocks latch bolt.

**WEIGHT:** 2.8 lbs. (1.27kg)

**NOTE:** MAY BE USED IN SINGLE OR DOUBLE CYLINDER APPLICATIONS.

#### STANDARD FEATURES





# 2.5" (64mm) Backset Mortise Locks Heavy Duty Functions

h

17

REVISION  
APR 2005

## PASSAGE

Latch bolt by knob either side.

**WEIGHT:** 2.5 lbs. (1.13kg)

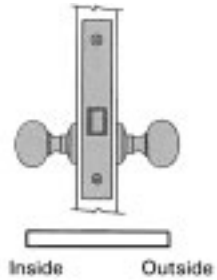

No. 6318 Knob Function  
No. 6318-LS Lever Function

## STANDARD FEATURES



## BATHROOM AND BEDROOM

Latch bolt by knob either side. Dead bolt by turn piece inside and emergency key No. 0417 outside.

1" (25mm) throw dead bolt with saw-proof inserts is standard equipment. When extended, dead bolt deadlocks latch bolt.

**WEIGHT:** 2.8 lbs. (1.27kg)

**\*NOTE:** For patio function, do not specify emergency release trim.

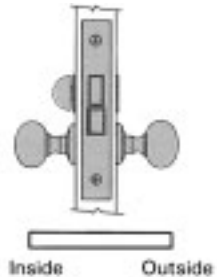

No. 6315\* Knob Function  
No. 6315-LS Lever Function

**RESERVED FOR  
FUTURE ADDITIONS**

TRIM SHOWN FOR ILLUSTRATION PURPOSES ONLY. SPECIFY LOCK NUMBER, FINISH, HAND, DOOR THICKNESS, AND TRIM DESIGN.

©2005 BALDWIN HARDWARE CORPORATION, READING, PA 19611

## 2.5" (64mm) Backset Mortise Locks Heavy Duty Functions

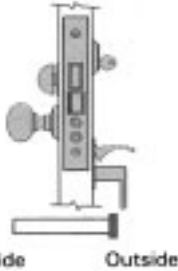

Inside Outside

No. 6320 Knob Function  
No. 6320-LS Lever Function

### RESIDENTIAL ENTRANCE

Latch bolt by thumb piece outside and knob inside, except when thumb piece is locked by stop in front; then latch bolt by key outside and knob inside. Dead bolt by key outside and turn piece inside. Continuous turn of key outside retracts both latch and dead bolt.

1" (25mm) throw dead bolt with saw-proof inserts is standard equipment. When extended, dead bolt deadlocks latch bolt.

**WEIGHT:** 3 lbs. (1.36kg)

**NOTE:** MAY BE USED IN SINGLE AND DOUBLE CYLINDER APPLICATIONS.

#### STANDARD FEATURES

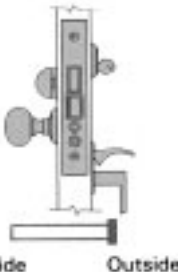

Inside Outside

No. 6321 Knob Function  
No. 6321-LS Lever Function

### RESIDENTIAL ENTRANCE— EMERGENCY EGRESS

Latch bolt by thumb piece outside and knob inside, except when thumb piece is locked by stop in front; then latch bolt by key outside and knob inside. Dead bolt by key outside and turn piece inside. When dead bolt is thrown, stop is automatically activated making outside thumb piece rigid. Inside knob retracts latch and dead bolt simultaneously but DOES NOT free outside thumb piece.

1" (25mm) throw dead bolt with saw-proof inserts is standard equipment. When extended, dead bolt deadlocks latch bolt.

**WEIGHT:** 3 lbs. (1.36kg)

**NOTE:** LOCK FUNCTION IS NOT REVERSIBLE – SPECIFY HAND.  
NOT RECOMMENDED FOR DOUBLE CYLINDER APPLICATIONS

#### STANDARD FEATURES



Inside Outside

No. 6325

### ENTRANCE

Latch bolt by thumb piece from either side, except when outside thumb piece is locked by stop in front; then latch bolt by key either side and thumb piece inside. Dead bolt by key either side, continuous turn of key retracts both latch and dead bolt.

1" (25mm) throw dead bolt with saw-proof inserts is standard equipment. When extended, dead bolt deadlocks latch bolt.

**WEIGHT:** 3.3 lbs. (1.50kg)

**NOTE:** To order and price complete trim sets, order two sets of exterior handle trim in "BBXX" configuration. Baldwin turn piece cylinder 844X.XXX may be used for interior.

#### STANDARD FEATURES



# Interior Mortise Locks

## 2.5" (64mm) BACKSET—SPECIFICATIONS

**FEATURES:** Case is formed from heavy gauge steel for strength and assures solid fit in mortise preparation. Vital interior working parts are made of solid hot forged brass for a lifetime of trouble-free operation. Completely reversible for all door conditions.

**STEEL CASE:** .625" × 3.375" × 3.75" (16 × 86 × 95mm)

**FRONT:** Hot-forged brass .156" × 1" × 5.75" (4 × 25 × 133mm). Adjustable for beveled conditions; finished to match.

**LATCH BOLT:** .5" × .625" (13 × 16mm) × .5" (13mm) throw. Furnished in US4 and 26D finishes to match trim.

**DEAD BOLT:** .5" × .75" (13 × 19mm) × .5" (13mm) throw. Furnished in US4 and 26D finishes to match trim.

**HUB SIZE:** .29" (7mm). Broached on the diamond.

**BACKSET:** 2.5" (64mm)

**SPACING:** Knob hub to turn piece: 2.25" (57mm)

**STRIKE:** Specially-designed curved lip strike is fully reversible (non-handed); available in 1.25" (32mm) Lip to Center dimension only.

**DUST BOX:** Box is furnished unattached; conceals installation marks and cutouts. (No. 8530-000)

**PACKED:** One in a box with a strike, dust box, and fasteners.

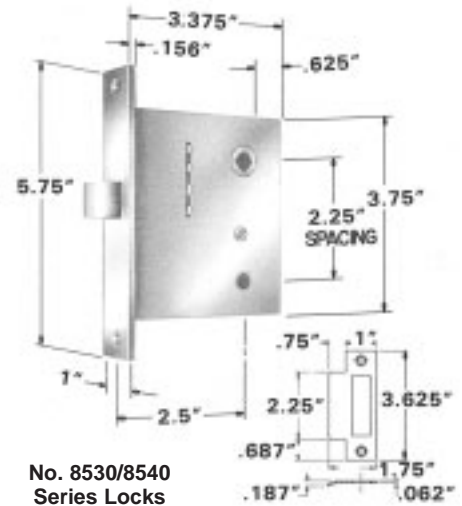

### PASSAGE

No. 8530

**FUNCTION:** Latch bolt by knob either side.

**WEIGHT:** 1.2 lbs. (.54kg)

**\*NOTE:** Lock may be installed in either of the illustrated positions.

#### INSTALLATION METHODS\*



### PASSAGE

No. 8535

**FUNCTION:** Latch bolt by lever either side.

**WEIGHT:** 1.2 lbs. (.54kg)

**\*NOTE:** Lock may be installed in either of the illustrated positions.

#### INSTALLATION METHODS\*



### PRIVACY

No. 8540

**FUNCTION:** Latch bolt by knob either side. Dead bolt by turn piece inside and Emergency Key No. 0417 outside.

**WEIGHT:** 1.5 lbs. (.68kg)

**\*NOTE:** Lock may be installed in either of the illustrated positions.

#### INSTALLATION METHODS\*



### PRIVACY

No. 8545

**FUNCTION:** Latch bolt by lever either side. Dead bolt by turn piece inside and Emergency Key No. 0417 outside.

**WEIGHT:** 1.5 lbs. (.68kg)

**\*NOTE:** Lock may be installed in either of the illustrated positions.

#### INSTALLATION METHODS\*



**ORDERING INSTRUCTIONS:** Locks are supplied as illustrated in left column. To install locks as illustrated in right column, specify the OPPOSITE HAND OF THE DOOR. Refer to Ordering Instructions in this catalog section. Turn Pieces and Emergency Release Trim must be ordered separately (NOT included in price of lock).

**h**

**20**

REVISION  
APR 2005

# Security Mortise Locks

**RESERVED FOR  
FUTURE ADDITIONS**

# 1.5" (38mm) and 2" (51mm) Narrow Backset Mortise Locks—Specifications

## STANDARD DUTY LEVER FUNCTION MORTISE LOCKS FOR DOORS 1.375" (35mm)/1.75" (44mm) THICK AND OVER

**LOCK SPECIFICATIONS:** Standardized heavy steel case is smooth, easy to mortise, and assures snug and solid fit in door mortise. Vital interior working parts are made of solid hot forged brass or steel for a lifetime of trouble-free operation. Armored front provides maximum strength and protection against tampering. Most lock functions are completely reversible. The bevel of front is adjustable from flat to standard bevel .125" on 2" (3mm on 51mm). Most metal door and frame manufacturers have provided reinforcements for Baldwin Mortise Locks.

**STEEL CASE:** 1.5" Backset: .75" × 1.5" × 5.5"  
(19 × 64 × 140mm)  
2.0" Backset: .75" × 3" × 5.5"  
(19 × 76 × 140mm)

**FRONT\*:** Hot forged brass .218" × 1" × 8" (6 × 25 × 203mm). Adjustable for beveled conditions.

\*Optional 1.25" (32mm) front available. Furnished standard with a curved lip strike. Consult price list.

**SCALP:** Wrought brass and bronze, available in standard finishes.

**LATCH BOLT:** Hot forged brass .5" × 1" (13 × 25mm) × .5" (13mm) throw. Furnished in US4 and 26D finishes to match trim.

**DEAD BOLT:** .5" × 1.25" (13 × 32mm) × .5" (13mm) throw. Furnished in US4 and 26D finishes to match trim.

**HUB SIZE:** .29" (7mm) with one-way rotation. Broached on the diamond.

**BACKSET:** 1.5" (38mm) and 2" (51mm)

**SPACING:** Center to center of:  
Knob Hub to cylinder 3.437" (87mm)  
Knob Hub to turn piece 2.25" (57mm)

**CYLINDER:** Standard mortise type with 03 keyway and two nickel silver keys. Cylinder must be purchased separately.

**KEYING:** All levels of Keying including Construction Keying are available. For additional information, refer to Section K.

**STRIKE:** Wrought brass and bronze finished to match. Supplied to ANSI standard A115.1, 1.25" (32mm) lip to center. Locks are furnished standard with curved lip strike (handed) and dust box. Special length strikes available. All KEYED lock functions are furnished standard with a high grade **steel security strike** and two 3" steel screws.

**TEMPLATE:** Metal doors/frames to be prepared in accordance with ANSI A115.1 or A115.11. FACE CUTOUTS ARE SUBJECT TO VARIATION. ALWAYS REVIEW TRIM REQUIREMENTS BEFORE DOOR PREPARATION.

**SPINDLE SYMBOLS:**

	Swivel Spindle
	Solid Spindle
	Half Spindle

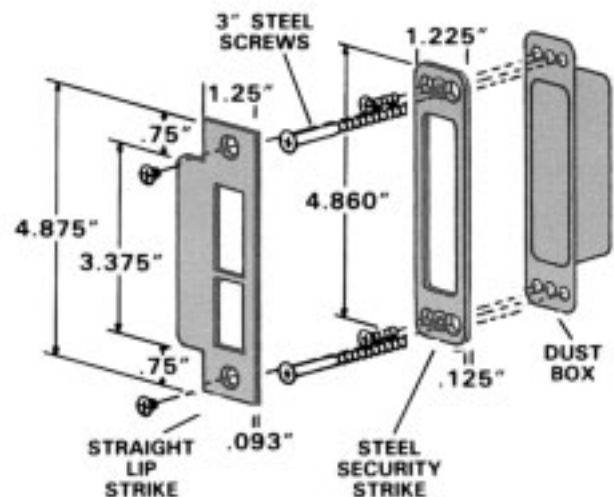
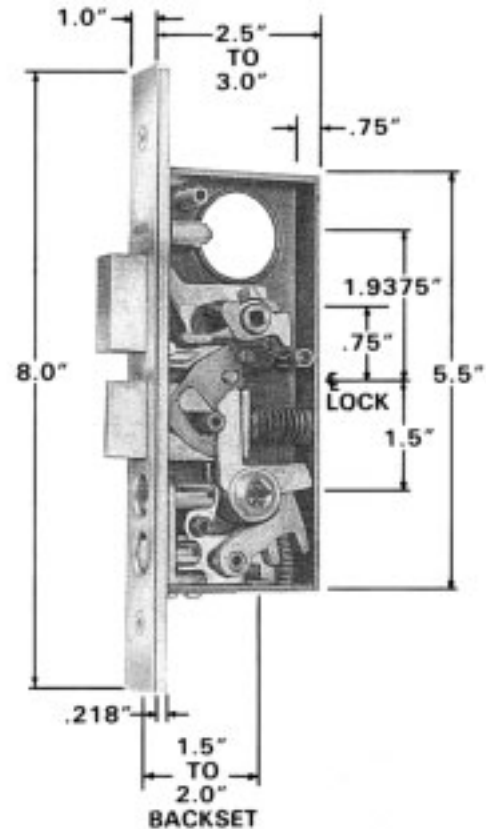

**NOTE:** 1.5" and 2.0" Backset Locks are designed to be used with levers. If knobs are specified, customer should be advised that the knob will only turn in one direction and will have a stiff turning action: NOT RECOMMENDED.

# 1.5" (38mm) and 2" (51mm) Narrow Backset Mortise Locks—Functions

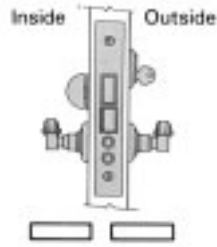

No. 6800—1.5" (38mm)  
No. 6802—2.0" (51mm)

## ENTRANCE AND APARTMENT

Latch bolt by lever from either side, except when outside lever is locked by stop in front; then latch bolt by key outside and lever inside. Dead bolt by key outside and turn piece inside. Continuous turn of key outside retracts both latch and dead bolt.

**WEIGHT:** 2.4 lbs. (1.09kg)

**NOTE:** MAY BE USED IN SINGLE AND DOUBLE CYLINDER APPLICATIONS.

### STANDARD FEATURES

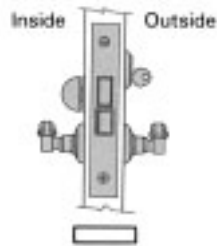

No. 6810—1.5" (38mm)  
No. 6812—2.0" (51mm)

## ENTRANCE AND STOREROOM

Latch bolt by lever either side. Dead bolt by key outside and turn piece inside.

**WEIGHT:** 2.4 lbs. (1.09kg)

**NOTE:** MAY BE USED IN DOUBLE OR SINGLE CYLINDER APPLICATIONS.

### STANDARD FEATURES



**RESERVED FOR  
FUTURE ADDITIONS**

**NOTE:** 1.5" and 2.0" Backset Locks are designed to be used with levers. If knobs are specified, customer should be advised that the knob will only turn in one direction and will have a stiff turning action: **NOT RECOMMENDED.**

TRIM SHOWN FOR ILLUSTRATION PURPOSES ONLY. SPECIFY LOCK NUMBER, FINISH, HAND, DOOR THICKNESS, AND TRIM DESIGN.

# 1.5" (38mm) and 2" (51mm) Narrow Backset Mortise Locks—Functions

**h**  
**23**  
REVISION  
APR 2005

## BATHROOM AND BEDROOM

Latch bolt by lever either side. Dead bolt by turn piece inside and emergency key No. 0417 outside.

**WEIGHT:** 2.2 lbs. (1kg)

**\*NOTE:** For Patio Function, do not specify emergency release trim.

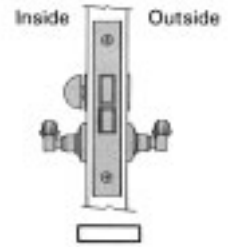

No. 6845\*—1.5" (38mm)  
No. 6847\*—2.0" (51mm)

## PASSAGE

Latch bolt by lever either side.

**WEIGHT:** 2 lbs. (.91kg)

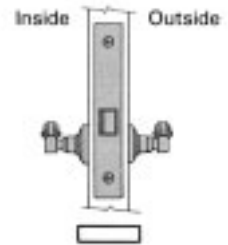

No. 6855—1.5" (38mm)  
No. 6857—2.0" (51mm)

## STANDARD FEATURES



## RESIDENTIAL ENTRANCE

Latch bolt by thumb piece outside and lever inside, except when thumb piece is locked by stop in front; then latch bolt by key outside and lever inside. Dead bolt by key outside and turn piece inside. Continuous turn of key outside retracts both latch and dead bolt.

**WEIGHT:** 2.4 lbs. (1.09kg)

**NOTE:** MAY BE USED IN SINGLE AND DOUBLE CYLINDER APPLICATIONS.

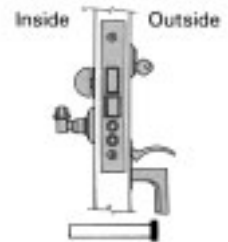

No. 6830—1.5" (38mm)  
No. 6832—2.0" (51mm)

**NOTE:** 1.5" and 2.0" Backset Locks are designed to be used with levers. If knobs are specified, customer should be advised that the knob will only turn in one direction and will have a stiff turning action: **NOT RECOMMENDED.**

TRIM SHOWN FOR ILLUSTRATION PURPOSES ONLY. SPECIFY LOCK NUMBER, FINISH, HAND, DOOR THICKNESS, AND TRIM DESIGN.

# 1.5" (38mm) Narrow Backset Mortise Locks Mortise Dead Locks—Functions



No. 6850

## SINGLE CYLINDER

Dead bolt by cylinder key one side only.

Furnished standard with No. 8300 Cylinder Collar.

**WEIGHT:** 2 lbs. (.91kg)

**NOTE:** MAY BE USED IN SINGLE AND DOUBLE CYLINDER APPLICATIONS.

STANDARD  
FEATURES



No. 6860

## TURN PIECE/CYLINDER

Dead bolt by cylinder key outside and turn piece inside.

Furnished standard with No. 8300 Cylinder Collar and No. 6750 Turn Piece. Other turn pieces are available as illustrated in this section at appropriate substitution of price.

**WEIGHT:** 2.3 lbs. (1.04kg)

STANDARD  
FEATURES



**NOTE:** 1.5" and 2.0" Backset Locks are designed to be used with levers. If knobs are specified, customer should be advised that the knob will only turn in one direction and will have a stiff turning action: **NOT RECOMMENDED.**

TRIM SHOWN FOR ILLUSTRATION PURPOSES ONLY. SPECIFY LOCK NUMBER, FINISH, HAND, DOOR THICKNESS, AND TRIM DESIGN.



# Strikes

h

25

REVISION  
APR 2005

## LATCH/DEADBOLT FUNCTION

**SIZE:** Base: 1.25" × 4.875" (32 × 124mm) × 1.25" (32mm) Lip to Center

**THICKNESS:** .093" (2.3mm), brass material.

**SCREWS:** Furnished with No. 12 combination wood/machine screws, finished to match.

**TEMPLATE:** Designed to fit metal/wood frames prepared in accordance to ANSI A115.1/A115.11.

**FEATURES:** Furnished flat with rounded lip edges for universal use with left and right handed locks. Supplied standard with all locks incorporating an anti-friction latch bolt.

**CURVED LIP:** Available with a curved lip at no additional charge. Supplied standard with all locks incorporating a solid-type latch bolt. ALWAYS SPECIFY HAND OF DOOR. Example: 6340.XXX.R. Please see ordering instructions in this section.

**IMPORTANT:** No. 6040 – for use with locks incorporating a .625" (16mm) wide latch bolt (6000 Series). No. 6340 – for use with locks incorporating a .5" (13mm) wide latch bolt (6300 Series and 6800 Series locks).

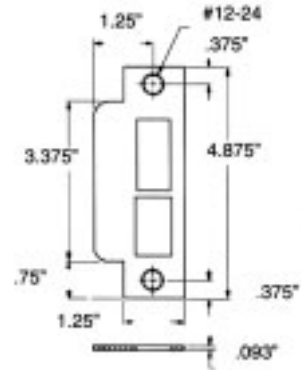

No. 6040  
No. 6340

## LATCH BOLT FUNCTION

**SIZE:** Base: 1.25" × 4.875" (32 × 124mm) × 1.25" (32mm) Lip to Center

**THICKNESS:** .093" (2.3mm), brass material.

**SCREWS:** Furnished with No. 12 combination wood/machine screws, finished to match.

**TEMPLATE:** Designed to fit metal/wood frames prepared in accordance to ANSI A115.1/A115.11.

**FEATURES:** Furnished flat with rounded lip edges for universal use with left and right handed locks. Supplied standard with all locks incorporating an anti-friction latch bolt.

**CURVED LIP:** Available with a curved lip at no additional charge. Supplied standard with all locks incorporating a solid-type latch bolt. ALWAYS SPECIFY HAND OF DOOR. Example: 6341.XXX.R. Please see ordering instructions in this section.

**IMPORTANT:** No. 6041 – for use with locks incorporating a .625" (16mm) wide latch bolt (6000 Series). No. 6341 – for use with locks incorporating a .5" (13mm) wide latch bolt (6300 Series and 6800 Series locks).

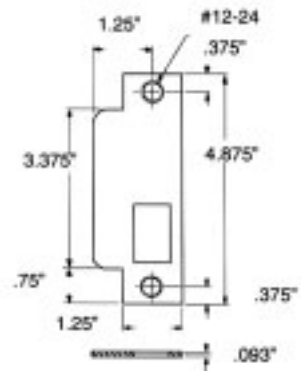

No. 6041  
No. 6341

## LATCH/AUXILIARY LATCH/DEADBOLT FUNCTION

**SIZE:** Base: 1.25" × 4.875" (32x124mm) × 1.25" (32mm) Lip to Center

**THICKNESS:** .093" (2.3mm), brass material.

**SCREWS:** Furnished with No. 12 combination wood/machine screws, finished to match.

**TEMPLATE:** Designed to fit metal/wood frames prepared in accordance to ANSI A115.1/A115.11.

**FEATURES:** Furnished flat with rounded lip edges for universal use with left and right handed locks. Supplied standard with all locks incorporating an anti-friction latch bolt.

**CURVED LIP:** Available with a curved lip at no additional charge. Supplied standard with all locks incorporating a solid-type latch bolt. ALWAYS SPECIFY HAND OF DOOR. Example: 6043.XXX.R. Please see ordering instructions in this section.

**IMPORTANT:** Strike designed for use with lock functions incorporating a latch, auxiliary latch, and dead bolt. Available for 6000 Series locks only.

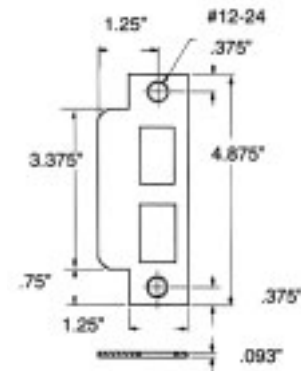

No. 6043

# Strikes

## HANDED

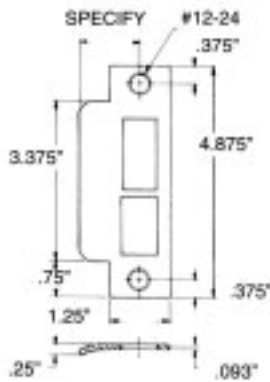

No. 6037  
No. 6038 No. 6039  
No. 6338 No. 6339

## EXTENDED LIP STRIKES

**SIZE:** 1.25" × 4.875" (32 × 124mm) × Specified Lip to Center.

**THICKNESS:** .093" (2.3mm), brass material.

**SCREWS:** Furnished with No. 12 combination wood/machine screws, finished to match.

**TEMPLATE:** Designed to fit metal/wood frames prepared in accordance to ANSI A115.1/A115.11.

**FEATURES:** Designed for use with locks installed on special door and frame conditions. Supplied with a curved lip only. ALWAYS SPECIFY HAND OF DOOR AND REQUIRED LENGTH.

**DIMENSIONS:** Available in the following Lip to Center lengths only: 1.625" (41mm); 1.875" (48mm); 2.25" (57mm); 3" (76mm).

**IMPORTANT:** Lip to Center length determined by the following formula:  
Door thickness ÷ 2 + .375" (10mm) = Lip to Center length. Round to closest size.

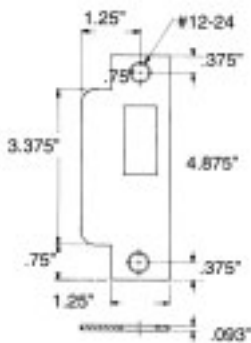

No. 6042

## DEAD BOLT FUNCTION

**SIZE:** 1.25" × 4.875" (32 × 124mm) × 1.25" (32mm) Lip to Center

**THICKNESS:** .093" (2.3mm), brass material.

**SCREWS:** Furnished with No. 12 combination wood/machine screws, finished to match.

**TEMPLATE:** Designed to fit metal/wood frames prepared in accordance to ANSI A115.1/A115.11.

**FEATURES:** Furnished flat with rounded lip edges for universal use with left- and right-handed locks.

**IMPORTANT:** Strike designed for use with lock functions incorporating a dead bolt. Available for 6000 Series and 6800 Series locks only.



No. 6001-000

## DUST BOX

**FEATURES:** Dust box designed to conceal installation cut-outs and marks behind strikes. Box measures 1" (25mm) deep for use with all lock functions and strikes. Furnished standard with all mortise locks illustrated within this section.

## ORDERING INSTRUCTIONS

To specifically order a strike with a Lip to Center dimension other than standard [1.25" (32mm)], use the following format: Strike Number-Finish-Hand/Required Length.

**EXAMPLES:** Item No. Finish Length\*

6040.030.R

6040.030.L

6338.030.R158

6339.030.L178

Strike - Right Hand

Strike - Left Hand

Strike × Right Hand × 1-5/8" L/C

Strike × Left Hand × 1-7/8" L/C

\***LENGTH:** The following designations are used to describe the hand/length of the strike.

R - Right Hand

158 - 1.625" Lip to Center

178 - 1.875" Lip to Center

L - Left Hand

214 - 2.25" Lip to Center

300 - 3" Lip to Center

# Armored Fronts

## ARMORED FRONT — 1.25" (32mm)

**FEATURES:** Removable armored fronts protect the lock against tampering of the cylinder yoke assembly. Available in all matching finishes of mortise locks.

**ORDERING INSTRUCTIONS:** Specify part number indicated below and finish required.

**IMPORTANT:** Fronts for use on 6000 Series Locks with 1.25" (32mm) wide front and .625" (16mm) wide latch bolt only.

PART NO.	FUNCTION
6010-xxx-0004	Latch/Dead Bolt
6021-xxx-0004	Latch/Dead Bolt/Stops
6060-xxx-0004	Latch/Auxiliary Latch/Stops
6065-xxx-0004	Latch/Auxiliary Latch
6080-xxx-0004	Latch/Auxiliary Latch/Dead Bolt/Stops
6091-xxx-0004	Latch/Auxiliary Latch/Dead Bolt
6110-xxx-0004	Latch
6150-xxx-0004	Dead Bolt

xxx - Insert Finish



6000 Series

## ARMORED FRONT — 1.25" (32mm)

**FEATURES:** Removable armored fronts protect the lock against tampering of the cylinder yoke assembly. Available in all matching finishes of mortise locks.

**ORDERING INSTRUCTIONS:** Specify part number indicated below and finish required.

**IMPORTANT:** Fronts for use on 6300 Series Locks (2.5" backset only) with a 1.25" (32mm) wide front and .5" (13mm) wide latch bolt.

PART NO.	FUNCTION
6301-xxx-0004	Latch/Dead Bolt/Stops
6310-xxx-0004	Latch/Dead Bolt
6318-xxx-0004	Latch

xxx - Insert Finish



6300 Series

## ARMORED FRONT — 1.25" (32mm)

**FEATURES:** Removable armored fronts protect the lock against tampering of the cylinder yoke assembly. Available in all matching finishes of mortise locks.

**ORDERING INSTRUCTIONS:** Specify part number indicated below and finish required.

**IMPORTANT:** Fronts for use on 6800-6802 Series Locks (1.5" and 2" backset) Locks with a 1.25" (32mm) wide front and .5" (13mm) wide latch bolt.

PART NO.	FUNCTION
6150-xxx-0004	Dead Bolt
6800-xxx-0004	Latch/Dead Bolt/Stops
6810-xxx-0004	Latch/Dead Bolt
6855-xxx-0004	Latch

xxx - Insert Finish



6800 Series

# Armored Fronts

## ARMORED FRONT — 1" (25mm)

**FEATURES:** Removable armored fronts protect the lock against tampering of the cylinder yoke assembly. Available in all matching finishes of mortise locks.

**ORDERING INSTRUCTIONS:** Specify part number indicated below and finish required.

**IMPORTANT:** Fronts for use on 6300 Series Locks (2.5" backset only) with a 1" (25mm) wide front and .5" (13mm) wide latch bolt.

PART NO.	FUNCTION
6301-xxx-0084	Latch/Dead Bolt/Stops
6310-xxx-0084	Latch/Dead Bolt
6318-xxx-0084	Latch

xxx - Insert Finish



6300 Series

## ARMORED FRONT — 1" (25mm)

**FEATURES:** Removable armored fronts protect the lock against tampering of the cylinder yoke assembly. Available in all matching finishes of mortise locks.

**ORDERING INSTRUCTIONS:** Specify part number indicated below and finish required.

**IMPORTANT:** Fronts for use on 6800-6802 Series (1.5" and 2" backset) Locks with a 1" (25mm) wide front and .5" (13mm) wide latch bolt.

PART NO.	FUNCTION
6150-xxx-0084	Dead Bolt
6800-xxx-0084	Latch/Dead Bolt/Stops
6810-xxx-0084	Latch/Dead Bolt
6855-xxx-0084	Latch

xxx - Insert Finish



6800 Series

**RESERVED FOR  
FUTURE ADDITIONS**