



SEISMIC EVALUATION OF HOSPITAL PIPING SYSTEMS

Elliott GOODWIN¹, Emmanuel MARAGAKIS², Ahmad ITANI³

SUMMARY

This paper presents findings from shake table experiments on cable-braced and unbraced welded hospital piping systems. The research identifies the capacity characteristics of a hospital piping system with and without bracings as well as the system's weak points. The system was tested to the ICBO AC156 acceptance criteria for nonstructural components. Preliminary results show that the braces limited the displacements, but they did not significantly reduce the accelerations of the system. The input motion of 1g was amplified to 2.6g at the top of the braced and unbraced piping systems. There was no significant damage to the piping system due to the high displacements and accelerations. Two of the eleven braces failed at the highest input excitation, two ½" diameter vertical hanger rods failed during the unbraced tests and a flanged connection began to leak during a pushover test.

INTRODUCTION

The functioning of an essential facility, such as a hospital, after an earthquake relies heavily on proper functioning of its nonstructural components such as fire suppression and water distribution systems, elevators and medical equipment. In recent earthquakes, nonstructural components in hospitals and medical buildings have suffered a large amount of damage, which resulted in a significant reduction of the functionality of the facilities. The 1971 San Fernando Earthquake caused severe damage to many hospitals and medical facilities. As a result of that damage, 4 of the 11 damaged medical facilities in the area had to be evacuated, Wasilewski [1]. Due to this unacceptable performance, the State of California passed the Hospital Seismic Safety Act, which required that medical facilities be designed and built to remain operational after an earthquake event, Ayres [2]. In order to restrict the movement of piping systems, the Sheet Metal Industry Fund of Los Angeles published the "Guidelines for Seismic Restraint of Mechanical Systems" in 1976, Wasilewski [1]. Other entities have come out with restraint guidelines for nonstructural components. The National Fire Protection Association has had seismic restraint guidelines since 1939, Ayres [2]. The Seismology Committee of the Structural Engineers Association of California has published seismic restraint guidelines since 1959, Ayres [2].

The above guidelines are reviewed after every major earthquake. For example, after the 1994 Northridge earthquake, 88% of the beds in the damage area (13 hospitals) had to be evacuated due to primarily

¹ Graduate Research Assistant, University of Nevada, Reno, USA.

² Chair and Professor, University of Nevada, Reno, USA.

³ Associate Professor, University of Nevada, Reno, USA.

nonstructural damage such as water damage, elevator failure, etc, Ayres [2]. This prompted a major review of the existing building codes and design force levels on nonstructural systems. Before the 1997 Uniform Building Code (1997 UBC), International Conference of Building Officials [3], codes did not require the design level force to change with respect to the height of the nonstructural component connection.

Seismic Bracing

The two primary types of seismic restraint for piping systems are solid and cable braces. Both types have a vertical support rod. The cable bracing forces the vertical support rod to be in compression, regardless of the direction of the seismic force. This may cause the vertical support rod to buckle. This is the reason why bracing manufacturers require an angle or strut to be clamped to the vertical support rod. The solid brace, when in compression, causes the support rod to go into tension. This tension may cause pullout failure at the connection point, which can be dangerous when support rods are anchored to concrete slabs, Lama [5].

Objectives

Due to the complexity of hospital piping systems, there are many unknown aspects of the behavior of these systems during an earthquake. The objectives of this set of experimental tests are to increase the understanding of the seismic behavior of welded hospital piping systems and to identify their capacity characteristics and weak points.

EXPERIMENTAL SPECIMEN

Background

In consultation with California Office of Statewide Health Planning and Development (OSHPD) engineers, the experimental hospital piping system was modeled after a system in the University of California, Davis medical center. The system was modified slightly to accommodate the dimensions and geometry restrictions of the shake table facility.

Piping System

The system was made up of approximately 100' of 3" and 4" diameter schedule 40 ASTM A53 grade A black steel pipe. The system includes two water heaters, one simulated heat exchanger, one y-strainer (61 lbs), one check valve (80lbs) and two gate valves (83 lbs/valve). The water heaters were connected to the system through a 4 bolt flanged connection. The heat exchanger and all of the valves were connected to the pipes through an 8 bolt flanged connection. All of the elbow to pipe connections were welded using a shielded metal arc welding process. The system was filled with room temperature water prior to the experiments. The only pressure in the system was the hydrostatic pressure caused by the water. The system was painted with a white wash to aid in observing cracks and leakage. The water heaters and the heat exchanger were anchored to the shake table and the pipes were braced and hung from a stationary frame, which rested on the lab floor, as shown in Figure 1. The fixed frame permitted direct measurement of relative displacements. Figures 2 and 3 illustrate the plan and elevation views of the system. The water heaters were braced on the table to avoid premature failure of the piping system due to excessive rigid body motion of the water heaters.



Figure 1. Experimental Setup

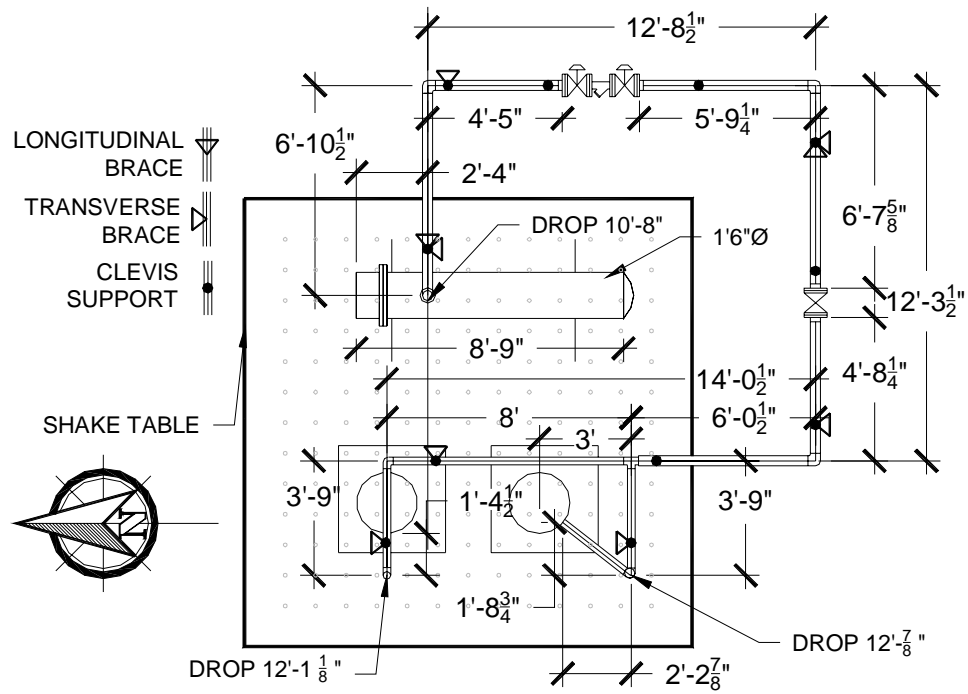

Figure 2. Plan View of Experimental Setup

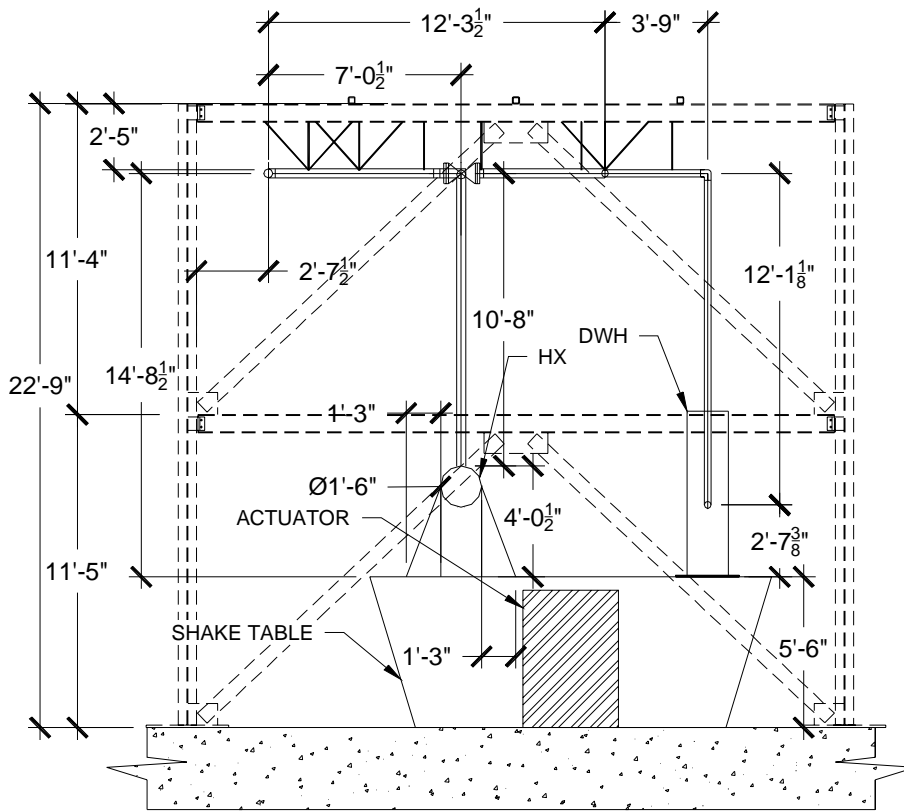

Figure 3. Elevation View of Experimental Setup

Seismic Restraints

The bracings used were cable style braces as shown in Figure 4. There were seven brace points and four hanger points in which there were vertical supports only. Figure 5 illustrates the bracing layout. This layout illustrates the bracing numbers that will be used later in this paper. The cables were made of 1/8" diameter prestretched galvanized 7x19 aircraft grade steel. The vertical hanger rods were of two sizes: 5/8" diameter all-thread rod for supporting the 4" diameter pipe and 1/2" diameter all-thread rod for supporting the 3" diameter pipe. The vertical hanger rods were braced continuously along their length with 1 3/8" square, 12 gauge strut.

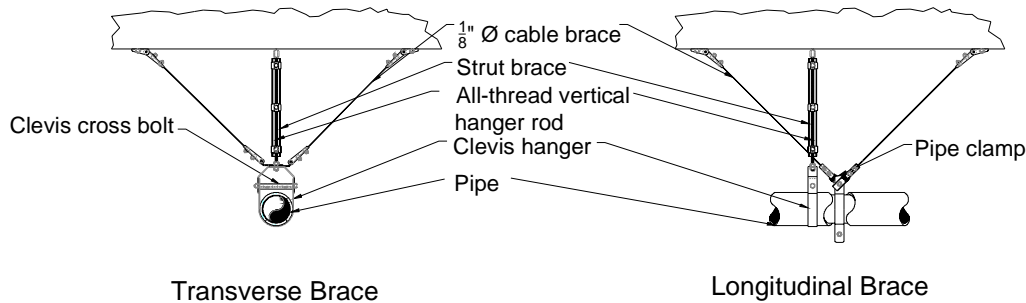

Figure 4. Typical Brace Details

Braced and Unbraced Piping Systems

Two systems, one braced and one unbraced, were tested in the experimental protocol. The unbraced system geometry and materials were the same as the braced system, except that the cable braces, the strut bracing the all-thread vertical rod and the clevis cross braces were removed. This reflects the unbraced condition of piping systems seen in the field.

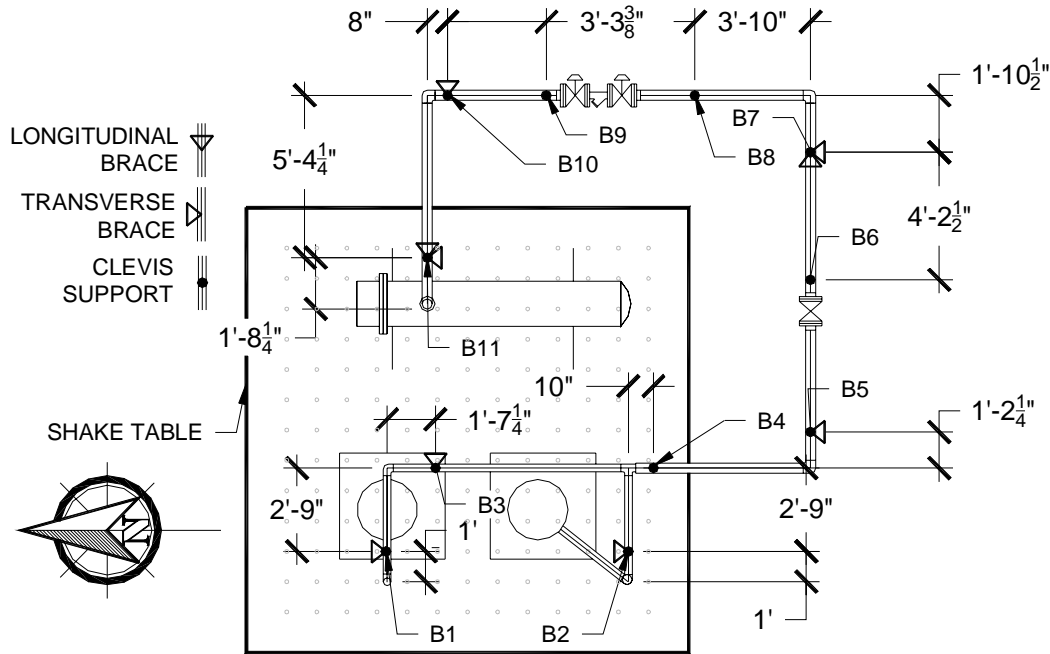

Figure 5. Seismic Restraint Location

TESTING CRITERIA

Response Spectrum Derivation

The piping system was tested to meet the ICBO AC156 Acceptance Criteria for Seismic Qualification Testing of Nonstructural Components, ICBO Evaluation Service, Inc. [6]. AC156 requires that the nonstructural component be subjected to a synthetic input motion that meets a response spectrum where the maximum spectral acceleration is determined according to the 1997 UBC formula:

$$A = 2.5C_a \left(1 + 3 \frac{h_x}{h_r} \right) < 4C_a \quad (1)$$

where:

C_a = seismic coefficient (1997 UBC Table 16-Q)

h_x = element or component attachment elevation with respect to grade

h_r = structure roof elevation with respect to grade

For this research, the following assumptions were made:

S_D soil type

$h_x = h_r$

$$C_a = 0.44N_a$$

Z = seismic zone factor (1997 UBC Figure 16-2)

$$Z = 0.4$$

N_a = near source factor (1997 UBC Table 16-S)

$$N_a = 1.5$$

$$C_a = 0.66$$

Formula (1) is derived from Equation 16-32-2 of the UBC. By using Formula (1), the maximum spectral acceleration was found to be 2.64g.

Synthetic Input Motion Generation

The AC156 requires that the input motion have a build, hold and decay curve of 5, 15 and 10 seconds, respectively and meet a desired response spectrum. The program SIMQKE, Gasparini [7], was used to generate a synthetic input motion, shown in Figure 6, which conforms to the AC156.

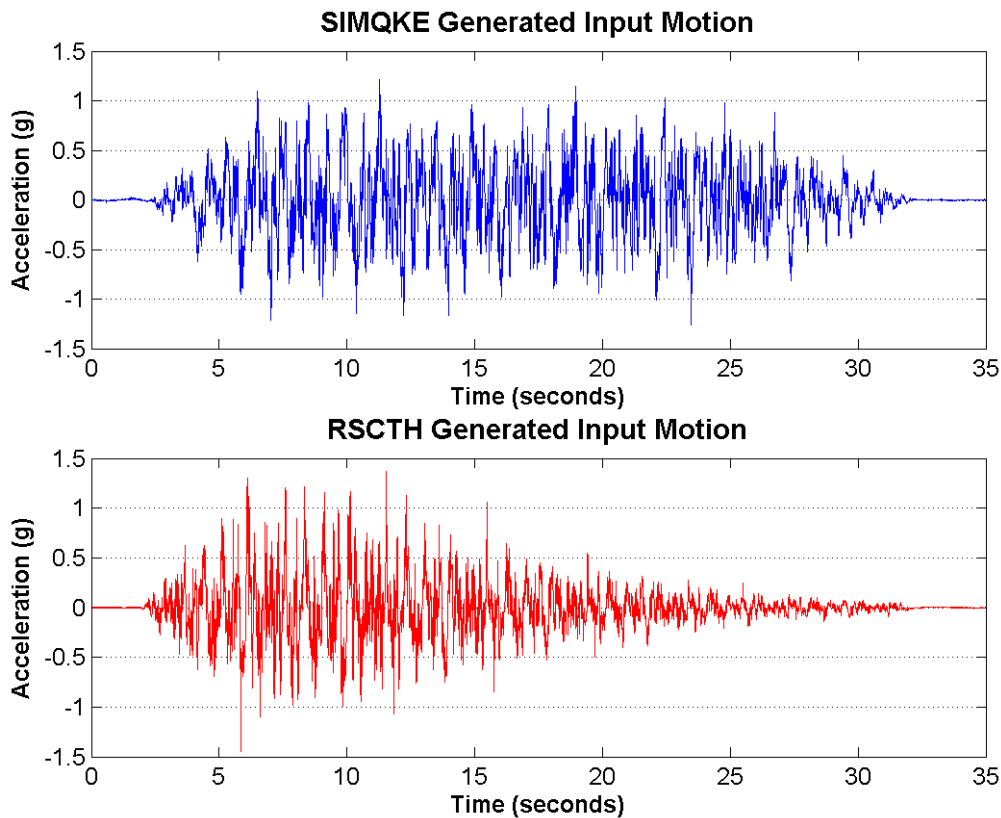

Figure 6. Synthetic Input Motions

A maximum acceleration of 1 g was chosen as the SIMQKE input. An additional synthetic motion using the program RSCTH, Halldorsson [8], was also generated (see Figure 6). The RSCTH motion met the response spectra as seen in Figure 7, but did not meet the AC156 due to the fact that it could not produce a motion that had a build, hold and decay envelope.

Figure 7 shows the required response spectra, the envelope that the AC156 requires the synthetic motion response spectra fall between, and the response spectra of the generated motions. Figure 8 illustrates the displacement and acceleration spectra for the SIMQKE motion.

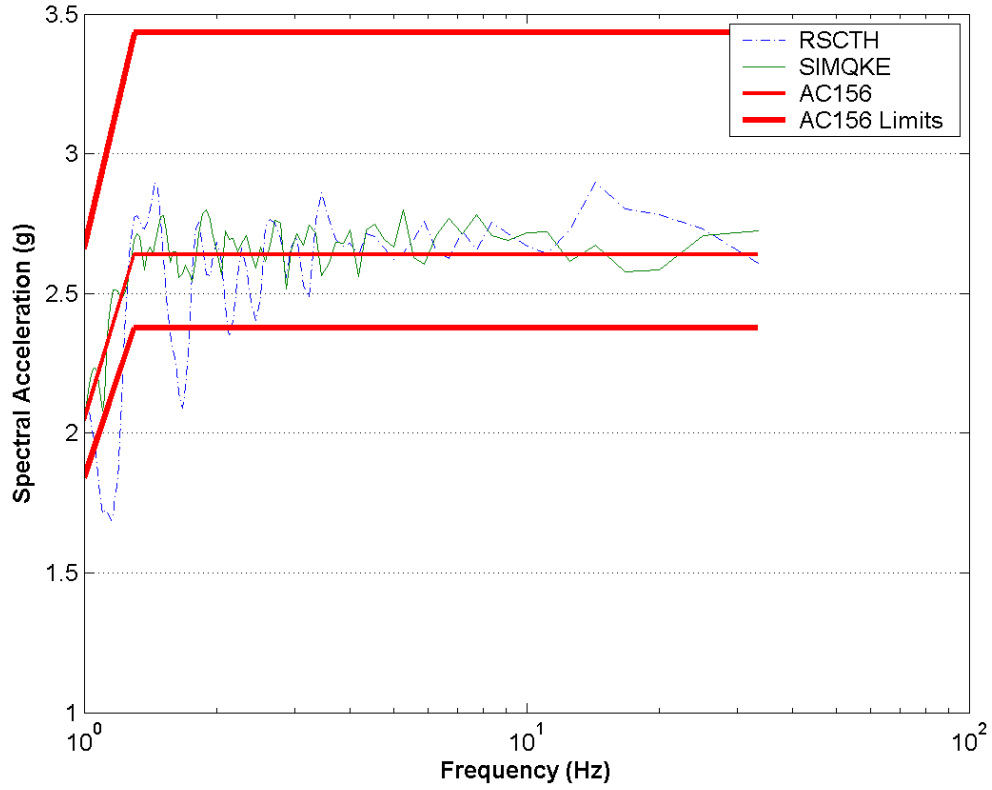

Figure 7. Response Spectra

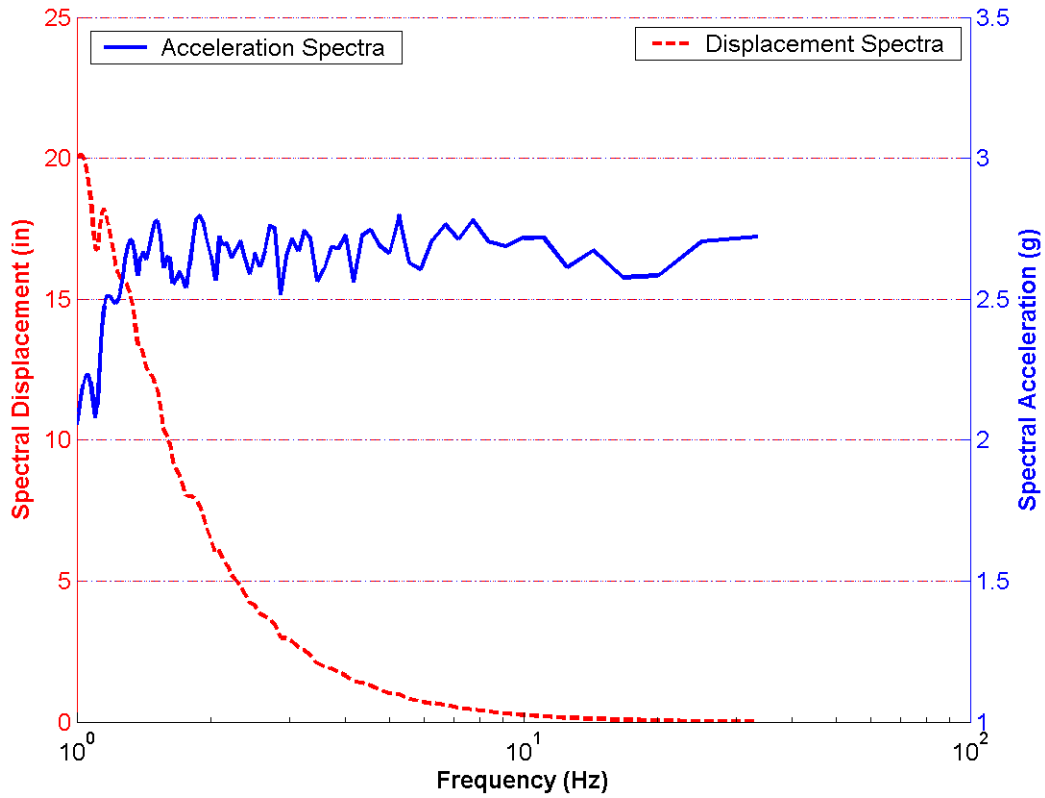

Figure 8. Acceleration and Displacement Spectra

INSTRUMENTATION PLAN

An instrumentation plan, seen in Figure 9, was developed for the experiment. The instrumentation consisted of 29 Celesco (20" stroke) displacement transducers and 16 Kinematics ($\pm 4g$) accelerometers. Displacement transducers and accelerometers were oriented in the vertical direction and in the direction perpendicular to the longitudinal axis of the pipe.

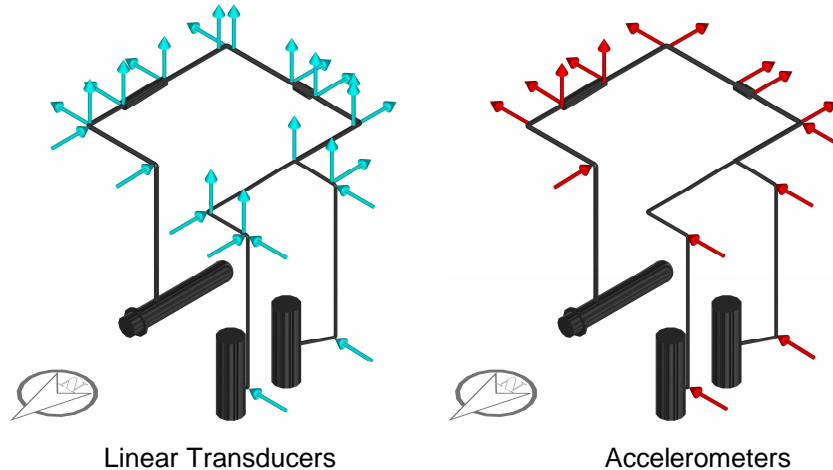

Figure 9. Instrumentation Plan

TESTING PROTOCOL

An testing protocol was developed that subjected the braced and unbraced systems to varying intensities of the SIMQKE and RSCTH motions in both principle axes (N-S, E-W directions can be seen in Figure 5) as well as a biaxial excitation at 45° with respect to the principle axes. Both systems were subjected to sine sweeps in all three directions. The braced system was also subjected to a dynamic pushover. Overall, the system was subject to 121 excitation motions.

EXPERIMENTAL RESULTS

Braced System

During the braced E-W 100% SIMQKE input motion two braces failed. The cable portion of both longitudinal brace #B11 and the transverse brace #B10 (see Figure 5 for brace positions) failed. Figure 10 illustrates the failure at the longitudinal portion of brace #B11. The flanged connection joining the heat exchanger to the pipe began to leak, as shown in Figure 11, during the 10" dynamic pushover.

White washing the surface of the pipes not only aided in identifying leaks, but also illustrated the permanent relative displacement of the braces to the piping system. Figure 12 shows that brace #B7's clevis scraped off the whitewash in the places it had touched the pipe during the excitation. Every brace point had at least 1" of permanent displacement after the testing of the braced system and brace #B2 moved permanently 4".



Figure 10. Brace #B11 Failure

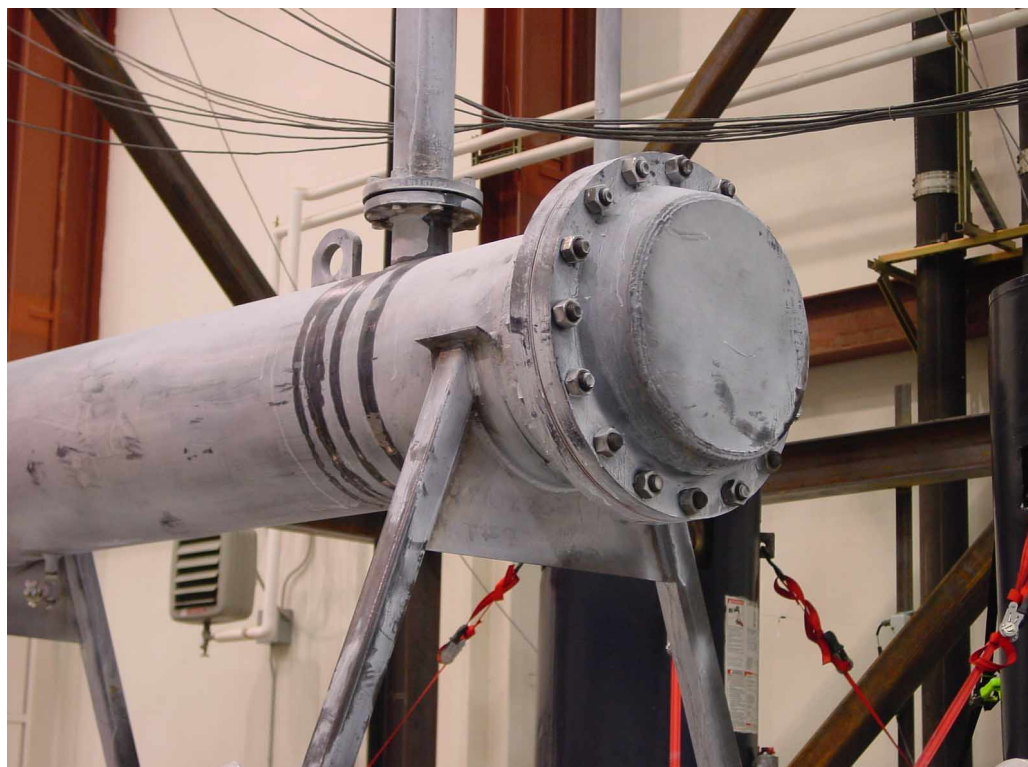

Figure 11. Heat Exchanger Leakage



Figure 12. Permanent Displacement of Brace #B7

Unbraced System

For the unbraced set of experiments, the brace points will be referred to as hangers. During the biaxial 100% SIMQKE input motion, hanger #B2 failed. The rod failed at the connection steel frame. Hanger #B1 failed in the same manner as hanger #B2 during biaxial 100% RSCTH motion. The only two rods to fail during the tests were ½” in diameter. None of the 5/8” diameter rods, which supported the 4” diameter pipe, failed.

Braced and Unbraced System Response Comparison

Figure 13 shows a comparison of the braced and unbraced displacement response of instrument nv17 at the highest SIMQKE input motion. As noted on the graph, the maximum unbraced displacement response for instrument nv17 was 9.65 in, and for the braced case the maximum displacement response for instrument nv17 was 3.56 in. Figure 13 also shows a comparison of the braced and unbraced acceleration response of instrument nv26, which was located at the same position as nv17. The maximum unbraced acceleration response for instrument nv26 was 2.64g and for the braced case, the maximum acceleration response was 2.65g. Similar behavior was observed in other instruments. The above can be explained by looking at the displacement and response spectra's for the SIMQKE motion shown in Figure 8. The accelerations are constant for frequencies between 2 and 33 Hz. However, the displacements drop off sharply for increasing frequency.

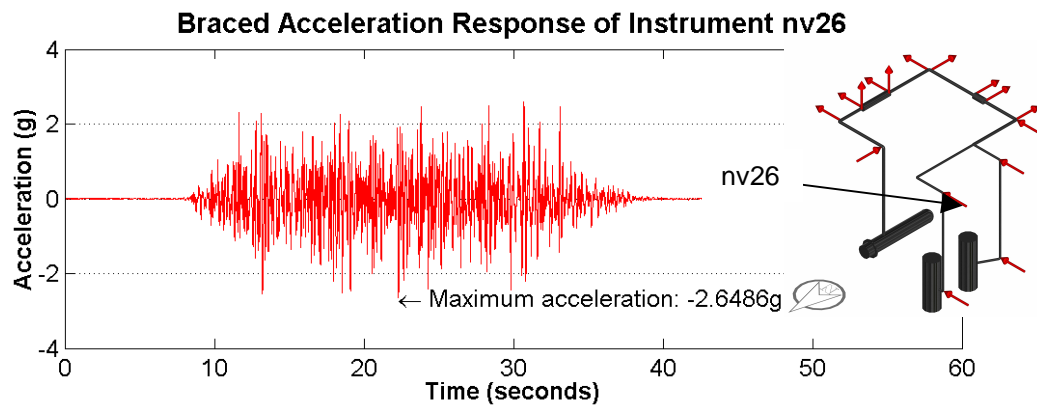
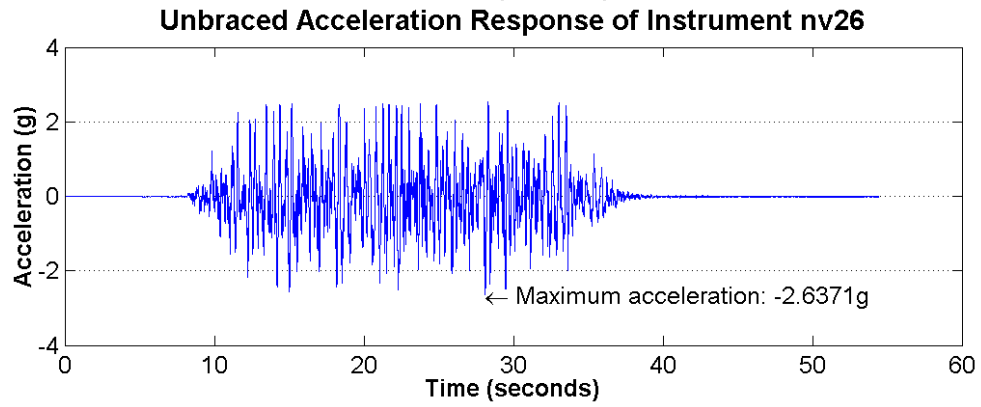
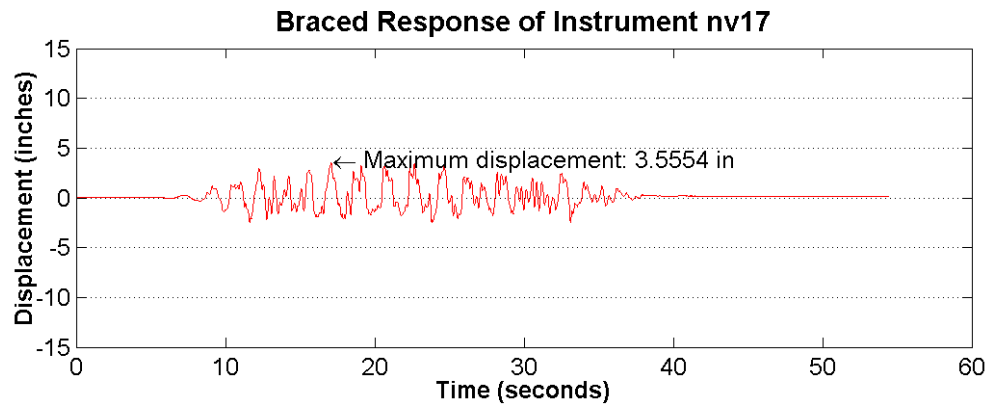
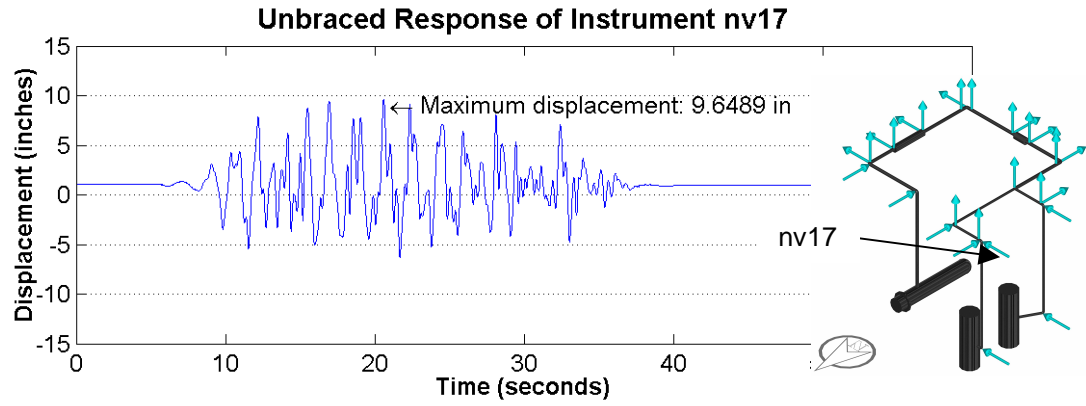

Figure 13. Response of Instruments nv26 and nv17

CONCLUSIONS AND OBSERVATIONS

The only leakage came during a 10" dynamic pushover experiment. Two cable braces failed during the highest input motions for the braced system, and two ½" diameter hanger rods failed during the highest input motion for the unbraced system. Due to the displacement and acceleration spectra for the SIMQKE input motion, the accelerations for the braced and unbraced systems were similar while the displacements for the braced system were smaller than the unbraced system.

Future Work

In late March of 2004, a system identical to that of the welded system will be tested. The only difference will be that the pipe will have threaded connections, not welded. It is expected that the threaded system will be more brittle than the welded system and will sustain much more damage.

Acknowledgements

This work is funded through the Multidisciplinary Center for Earthquake Engineering Research (MCEER). This financial support is gratefully acknowledged. Special thanks to William Staehlin of the California Division of the State Architect and Chris Tokas of the California Office of State Wide Health Planning and Development, David Ainsworth of Stecher-Ainsworth-Miner, Mechanical Engineers, Rich Lloyd of Mason Industries and Pete Rezac from Cooper B-Line.

REFERENCES

1. Wasilweski, R.J., 1998, "Seismic Restraints for Piping Systems," ASHRAE Trans. 1998, Vol. 104, Part 1, American Society of Heating, Refrigerating and Air-Conditioning Engineers, Atlanta, Georgia.
2. Ayres, J.M., Phillips, R.J., 1998, "Water Damage in Hospitals Resulting from the Northridge Earthquake," ASHRAE Trans. 1998, Vol. 104, Part 1, American Society of Heating, Refrigerating and Air-Conditioning Engineers, Atlanta, Georgia.
3. International Conference of Building Officials, 1997, "Uniform Building Code, Structural Engineering Design Requirements", Vol. 2, 1997 Edition, pp 2-24 to 2-35, Whittier, California.
4. ATC/SEAOC, 1999, "Seismic Response of Nonstructural Components, Part A: Overview of Component Types and Behavior", ATC/SEAOC Joint Venture Training Curriculum, Redwood City, California.
5. Lama, P., 1998, "Seismic Codes, HVAC Pipe Systems, and Practical Solutions", ASHRAE Trans. 1998, Vol. 104, Part 1, American Society of Heating, Refrigerating and Air-Conditioning Engineers, Atlanta, Georgia.
6. ICBO Evaluation Service, Inc., 2000, "Acceptance Criteria for Seismic Qualification Testing of Nonstructural Components", AC156, International Conference of Building Officials, Whittier, California.
7. Gasparini, D.A., and Vanmarcke, E.H., 1976 "Simulated Earthquake Motions Compatible with Prescribed Response Spectra," Massachusetts Institute of Technology, Cambridge, Massachusetts.

8. Halldorsson, B., Dong, G. and Papageorgiou, A.S., 2002, "Earthquake motion input and its dissemination via the Internet" Journal of Earthquake Engineering and Engineering Vibration, Vol. 1, No. 1, pp. 20-26. (<http://civil.eng.buffalo.edu/EngSeisLab/>)
9. Maragakis, E., Itani, A., and Goodwin, E., 2003, "Seismic Behavior of Welded Hospital Piping Systems", Proceedings of the Applied Technology Council (ATC) 29-2: Seminar on seismic design performance, and retrofit of nonstructural components in critical facilities, pp 321-333, Redwood City, California.
10. Goodwin, E., Maragakis, E., Itani, A., 2003, "Experimental Evaluation of the Seismic Performance of Hospital Piping Systems", Proceedings of the Structural Engineers Association of California (SEAOC) 72nd Annual Convention, pp 485-492, Squaw Creek, California.