

Seismic guidelines for stone-masonry components and structures

S.E. Chidiac

McMaster University, Hamilton, Ontario, Canada, Email: chidiac@mcmaster.ca

Abstract - Heritage stone-masonry structures were built at a time when little or no consideration is given to their performance requirements in the event of earthquakes. Recent earthquakes have confirmed the vulnerability of heritage un-reinforced stone-masonry buildings. The consequences of failure of stone-masonry structures are severe: human casualties, economic loss and property/heritage damage. Proper assessment of the seismic performance and identification of the potential deficiency of existing stone-masonry structures forms the basis for determining the degree of intervention needed to preserve their heritage value. While technical standards and guidelines are available for the seismic evaluation of commonly found brick masonry, concrete and steel construction, similar comprehensive documents for stone-masonry structures are not available. In Canada, many government and heritage buildings, such as the Parliament Buildings and the legislature buildings, are of stone-masonry construction. Furthermore, practicing engineers in Canada do not receive the proper training and knowledge to analyze and assess the structural behavior of building constructed of discontinuous materials such as stone-masonry. In view of the above, Public Works and Government Services Canada decided to develop guidelines specifically for the seismic assessment of stone-masonry structures. The purpose of developing these guidelines is to provide engineers and architects with technically sound analytical tools and applicable assessment criteria for the seismic evaluation of stone-masonry structures. This paper describes the development of the guidelines and provides a case study for illustrating their application.

1 Introduction

Most of the existing stone-masonry structures are classified as heritage, including Canada's Parliament buildings and provincial legislature buildings. These buildings were constructed at a time when little or no consideration were given to the structural requirements in the event of earthquakes. The majority of these stone-masonry structures are also located in highly populated areas such as the downtown cores of large cities such as Ottawa, Quebec City and Victoria. Inherently, they pose a potential seismic risk because cities like Ottawa, Quebec City and Victoria are located in moderate to high seismic zones within Canada¹.

Stone-masonry structures that were subjected to earthquakes are found to be vulnerable, but more critical is that their seismic performance is found inconsistent²⁻⁵. Because of their locations and use, the consequences of failure of these stone-masonry structures tend to be severe with regards to human casualties, economic loss and property/heritage damage. Therefore, adequate assessment of the

seismic performance and identification of the potential deficiency of stone-masonry structures are critical steps for determining the degree of intervention needed to preserve their heritage value.

Both Canada and the US have guidelines on the seismic evaluation of buildings constructed with engineered materials such as brick and block masonry, concrete and steel, but not for those constructed with stone-masonry⁶⁻⁸. In addition, today's engineering programs provide professional engineers with no training and little knowledge in the structural analysis, design, and construction of structures built with discontinuous materials such as stone-masonry. Recognizing these shortcomings, Public Works and Government Services Canada (PWGSC) developed a document entitled "Guidelines for the seismic assessment of stone-masonry structures"⁹ in order to provide engineers and building owners and officials with technically sound analytical tools and applicable assessment criteria for the seismic evaluation of stone-masonry structures. In addition, PWGSC has developed a draft document entitled "Guidelines for the seismic upgrading of stone-masonry structures"¹⁰. The scope of the upgrading guidelines is to provide design professionals with the different seismic upgrading techniques for stone-masonry to mitigate the life safety hazards during an earthquake. The purposes of the two documents are to help design professionals evaluate stone-masonry structures for seismic hazards and recommend adequate upgrading, and to help building owners identify potential seismic hazards. It is PWGSC's intent to continue developing these guidelines into a comprehensive national standard in cooperation with national and international institutions such as CIB and ICOMOS.

This paper describes the development of the first guidelines on the seismic assessment of stone-masonry structures and their application to an un-reinforced stone-masonry tower.

2 Scope and contents of the guidelines

2.1 Scope

The guidelines are intended for one type of structure — stone-masonry. They provide methods for assessing the ability of stone-masonry structures to resist the forces of inertia generated by the shaking of the ground during an earthquake. The guidelines include seismic provisions for both the structural subsystems such as walls, domes, or buttresses, and for the non-structural subsystems of the structures such as parapets, or chimneys.

The criteria put forward in the guidelines are compatible with NBC 1995 seismic provisions¹. The acceptable level of safety required by NBC 1995 is achieved by complying with the minimum base shear and other specified seismic provisions. Performance acceptance criteria for these guidelines are developed on the basis of strength and deformation.

2.2 Contents of the guidelines

The guidelines consist of eight chapters and one appendix. Chapter 1, *Introduction*, presents the purpose, the basis, and the contents of the guidelines as well as a brief discussion in regards to heritage considerations. Chapter 2, *Earthquake behavior of stone-masonry structures*, provides insight into the past seismic performance of stone-masonry structures, as previously reported in the literature. The common mechanisms of failure associated with typical structural subsystems and the identification of the main causes of failure are discussed. A structural checklist is introduced to identify potential structural weaknesses in existing stone-masonry bearing wall buildings with stiff diaphragm. Chapter 3, *Procedure for seismic evaluation of structures*, presents the basic procedure for the evaluation of the seismic performance of a structure. The procedure outlines steps such as site investigation, identification of structural and nonstructural subsystems, analysis of the structure and seismic performance evaluation of the building structure. Chapter 4, *Modeling and analysis*, provides a description of four methods of analysis: linear static, non-linear static, linear dynamic, and non-linear dynamic. Application of mathematical models to quantify the response of stone-masonry is presented. Chapter 5, *Material properties of stone-masonry*, examines the mechanical properties of stone-masonry, including the components. Destructive and non-destructive test methods, which have been used to measure the uniformity of the structure and the mechanical properties, are reviewed. Chapter 6, *Engineering properties of stone-masonry*, contains analytical tools for determining the stiffness and the distribution of forces, and for computing the resultant forces for structural stone-masonry subsystems. Methods of analysis for the seismic evaluation of non-structural subsystems typically constructed of stone-masonry are also presented. Chapter 7, *Seismic assessment criteria*, provides acceptance criteria for the seismic evaluation of structural and non-structural stone-masonry subsystems. The criteria are developed on the basis of strength and deformation. Chapter 8, *Closure*, provides closing statements on the development and application of the guidelines. Appendix A illustrates applications of the guidelines to an existing stone-masonry structure.

This paper focuses mainly on three elements of the guidelines: Earthquake behaviour of stone-masonry; Evaluation procedure for stone-masonry structures; and Assessment criteria for structural and non-structural stone-masonry components.

3 Earthquake behavior of stone-masonry structures

Engineers have generally associated stone-masonry structures with poor seismic performance. However, this is not the case as the performance of the stone-masonry structures during earthquakes is dictated by the quality of construction and the structural adequacy of the components. Quality of construction includes method of construction, quality of materials and workmanship; whereas structural adequacy encompasses all the factors required to keep the structure intact. For stone-masonry, structural adequacy is often a function of the adequacy of the anchorage or connection of components. In fact, the inadequacy of anchorage and particularly connection of components is the primary cause associated with the poor seismic performance of stone-masonry structure². To achieve adequate anchorage and connection depends on the method of construction, quality of materials and workmanship, and type of diaphragm.

In this chapter of the guidelines, a summary of the commonly observed failure mechanisms is provided for typical structural stone-masonry components, namely, walls, lintels, arches, vaults and

domes, buttress and flying buttress, towers and foundation, due to earthquake. For the non-structural components, a summary is provided for the veneers, pinnacles, appendages, parapets, cornices, statues and ornaments, and chimneys. In addition, a checklist is compiled for a preliminary identification of potential weakness in stone-masonry bearing wall buildings with stiff diaphragms. For this paper, only the mechanisms of failure for the wall and veneers are given.

3.1 Structural subsystem - walls

Wall is a structural subsystem, which provides resistance against gravity and lateral forces. Its capacity to resist lateral load depends on its aspect ratio, its orientation, the quality of the material and workmanship, and the adequacy of its connection to the rest of the structure. Examination of stone-masonry structures damaged by earthquakes has shown the followings:

Low shear resistance $\frac{3}{4}$ - Mortar used in the construction of stone-masonry often consists of lime and sand, with little or no Portland cement. This mortar mix is known to have little shear strength. Consequently, sliding along the mortar joint has been observed as one of the common failure mechanisms, resulting in either partial collapse of the bearing wall or total failure of the structure.

Inadequate connection between wythes $\frac{3}{4}$ - Poor connection between the two outer stone wythes with the middle constructed of rubble and mortar has exhibited poor seismic performance. Diagonal cracks and separation of the two wythes have occurred. Partial or total collapse of the bearing walls was observed (see Figure 1).

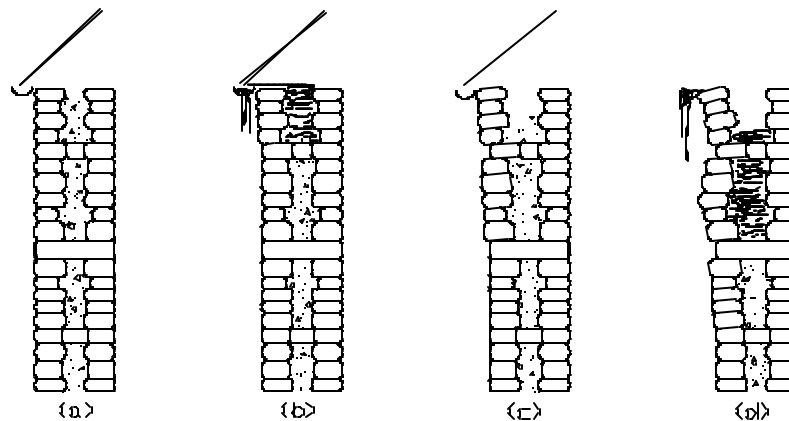

Figure 1. Inadequate connection between the outer wythes (a and b) results in the drifting apart of the outer wythe (c) leading to either partial or total collapse of the bearing wall (d).

Poorly engineered corner connection $\frac{3}{4}$ - Separation of the walls, followed by collapse, was observed in non-engineered buildings with inadequate wall corner detailing.

Large window openings $\frac{3}{4}$ In stone-masonry walls, large window openings cause reduction in lateral shear capacity. Diagonal tension failure was observed under seismic load.

Wall slenderness $\frac{3}{4}$ Slender walls have exhibited little resistance to lateral loads due to earthquake. Out-of-plane failure of walls not adequately connected at the top was frequently observed.

Flexible diaphragm $\frac{3}{4}$ The most common damage patterns observed in walls connected to flexible diaphragms are horizontal cracks at the floor-to-wall joints, or out-of-plane collapse of walls;

vertical cracks or separation between the walls at corner intersections; and diagonal cracks in walls, piers, and spandrels.

3.2 Non-structural subsystem – Veneers

Veneers are typically slender walls that are laterally connected to the main structure by mechanical anchors. Commonly observed failure mechanisms of veneers are: (1) fracture within the wall or failure of the mechanical connections between the wall and the structure due to stone-masonry’s heavy weight and inertia forces, (2) failure of the connections and/or failure of the stone units due to excessive deformation of the structural subsystem, and (3) connection failure due to corrosion of anchors and the resulting voiding of the mortar.

3.3 Structural checklist

Structural checklist, given in Table 1, has been compiled from past seismic performance of stone-masonry. The purpose of the checklist is to identify potential inadequacy in the seismic capacity of existing stone-masonry bearing wall buildings with stiff diaphragms. The checklist contains clauses that need to be satisfied. “C” represents “conforming”, a necessary requirement for the clauses to pass the evaluation process. For the clauses that are found “non-conforming” (NC), an in-depth evaluation is required to assess their potential seismic risk. N/A stands for “not applicable”. For those buildings whose structural subsystems do not conform to the required criterion, and for those subsystems that are not included in the checklist, further analysis is required to evaluate their seismic capacity.

For stone-masonry bearing-wall buildings with flexible diaphragms, either the horizontal-beam method or the plate method (as a quick check) or a refined analysis is required to determine the distribution of the seismic forces. Subsequently, the response and capacity of the structure can be evaluated according to the requirements of these guidelines.

The entry point to the checklist depends on the particular item under investigation. The site investigation and data collection have to be completed before any of the items can be evaluated. A considerable amount of analysis is often required.

Table 1. Basic structural checklist for stone-masonry bearing wall buildings with stiff diaphragms.

General				
C	NC	N/A	LOAD PATH: The structure contains one complete load path for seismic force effects from any horizontal direction that serves to transfer the inertial forces from the mass to the foundation.	Sec. 2.2
C	NC	N/A	WEAK STOREY: The strength of the lateral-force-resisting system in any storey is not less than 80% of the strength in an adjacent storey above or below.	Sec. 2.2
C	NC	N/A	SOFT STOREY: The stiffness of the lateral-force-resisting system in any storey is not less than 70% of the stiffness in an adjacent storey above or below or less than 80% of the average stiffness of the three stories above or below.	Sec. 2.2

C	NC	N/A	GEOMETRY: There is no change in horizontal dimension of the lateral-force-resisting system of more than 30% in a storey relative to adjacent stories, excluding one-storey penthouses.	Sec. 2.2
C	NC	N/A	VERTICAL DISCONTINUITIES: All vertical elements in the lateral-force-resisting system are continuous to the foundation.	Sec. 2.2
C	NC	N/A	MASS: There is no change in effective mass more than 50% from one storey to the next.	Sec. 2.2
C	NC	N/A	TORSION: The distance between the storey centre of mass and the storey centre of rigidity is less than 20% of the building width in either plan dimension.	Sec. 2.2
C	NC	N/A	MASONRY UNITS: There is no visible deterioration of stone-masonry units.	Sec. 2.2.2
C	NC	N/A	MASONRY JOINTS: The mortar is not easily scraped away from the joints by hand with a metal tool, and there are no areas of eroded mortar.	Sec. 2.2.2
C	NC	N/A	UNREINFORCED STONE-MASONRY WALL CRACKS: There are no existing diagonal cracks in wall elements greater than 1 mm, or out-of-plane offsets in the bed joint greater than 5.	Sec. 2.2 2.3.1
C	NC	N/A	UNREINFORCED STONE-MASONRY DOMES, ARCHES, etc., CRACKS: There are no existing vertical or horizontal cracks in dome and arch structural subsystems greater than 1 mm, or out-of-plane offsets in the bed joint greater than 5 mm.	Sec. 2.3.3 2.3.4
C	NC	N/A	MASONRY LAY-UP: filled collar joints of multi wythe masonry walls have negligible voids.	Sec. 2.2

Lateral Force Resisting System

C	NC	N/A	REDUNDANCY: The number of lines of shear walls in each principal direction is greater than or equal to 2.	Sec. 2.2
C	NC	N/A	SHEAR STRESS CHECK: The shear stress in the unreinforced-masonry shear walls, calculated using the Quick Check procedure of Section 3.4, is less than 0.1 MPa for rubble construction and less than $0.5 \sigma_D$ for coursed stone-masonry.	Sec. 3.4

Drift

C	NC	N/A	DRIFT: The drift ratio for stone-masonry walls is limited to 0.0015 for good quality coursed construction and 0.0003 for rubble construction.	Sec. 2.3.1 2.4.1
C	NC	N/A	PROPORTIONS: The height-to-thickness ratio of the shear walls of coursed stone-masonry at each storey is less than the following ():	Sec. 2.3.1

	Conditions	Seismic Zone		2.3.6
		High	Moderate to low	
	Top storey of multi-storey building	9	14	
	First storey of multi-storey building	15	18	
	All other conditions	13	16	

Connections

C	NC	N/A	WALL ANCHORAGE: Exterior stone-masonry walls are anchored for out-of-plane forces at each diaphragm level with steel anchors or straps that are developed into the diaphragm.	Sec. 2.2.4
C	NC	N/A	ANCHOR SPACING: Exterior masonry walls are anchored to the floor and roof systems at a maximum spacing of 1 m.	Sec. 2.3.1
C	NC	N/A	TRANSFER TO SHEAR WALLS: Diaphragms are reinforced and connected for transfer of loads to the shear walls.	Sec. 2.2.3
C	NC	N/A	DOMES, ARCHES, etc./COLUMN CONNECTION: There is a positive connection between the domes, arches, and all other stone-masonry structural systems and the column support.	Sec. 2.3.3 2.3.4 2.3.5

Diaphragms

C	NC	N/A	PLAN IRREGULARITIES: There is tensile capacity to develop the strength of the diaphragm at re-entrant corners or other locations of plan irregularities.	Sec. 2.2.3
C	NC	N/A	DIAPHRAGM CONTINUITY: The diaphragms are not composed of split-level floors.	Sec. 2.2.3
C	NC	N/A	CROSS TIES: There are continuous cross-ties between diaphragm chords.	Sec. 2.2.3
C	NC	N/A	ROOF CHORD CONTINUITY: All chord elements are continuous, regardless of changes in roof elevation.	Sec. 2.2.3

Stone-masonry Bearing Walls

C	NC	N/A	UNREINFORCED STONE-MASONRY: Unreinforced rubble stone-masonry is braced at a spacing of 3 m or less in regions of moderate seismicity, and 1.5 m in regions of high seismicity.	Sec. 2.3.1
---	----	-----	---	------------

Parapets, Cornices, Ornamentation and Appendages

C	NC	N/A	URM PARAPETS: There are no laterally unsupported, unreinforced stone-masonry parapets or cornices above the highest anchorage level with height-to-thickness ratios greater than 1.5 in regions of high seismicity and 2.5 in regions of moderate or low seismicity.	Sec. 2.4.3
---	----	-----	--	------------

Masonry Chimneys

C	NC	N/A	URM: Unreinforced stone-masonry chimneys do not extend above the roof surface more than twice the least dimension of the chimney.	Sec. 2.4.4
C	NC	N/A	MASONRY: Masonry chimneys are anchored to the floor and roof.	Sec. 2.4.4

Stairs

C	NC	N/A	URM WALLS: Walls around stair enclosures do not consist of unreinforced stone-masonry.	Sec. 2.3.1
---	----	-----	--	------------

4 Procedure for seismic evaluation of structures

Procedure for the evaluation of the seismic performance of a structure including stone-masonry structures consists of the following steps:

1. Site investigation and data collection
2. Identification of structural and nonstructural components of the structure
3. Analysis of the structure
4. Evaluation of the seismic performance of the structure components
5. Follow-up on-site inspection of accessible and critical components
6. Preparation and issuance of final report

4.1 Site investigation and data collection

The objective of this task is to gain an understanding of the composition, condition, and integrity of the structure. For heritage structures, the gathering of information should produce a brief history of the structure detailing the period and phases of its construction, and dates and details of structural and non-structural changes/repairs that have occurred over the life of the structure. Subtasks include initial site visit, preliminary visual inspection, assemble of building design data, review of repair and renovation work, detailed site survey, review of past performance of structures, and examination of soil conditions.

4.2 Identification of structural and non-structural subsystems

The following subsystems of a building structure are to be defined in accordance with their type and the construction material/method:

- Subsystems resisting lateral forces;
- Subsystems resisting only gravity loads;
- Diaphragms;
- Connections between the diaphragm and other structural subsystems;
- Connections between various structural subsystems;
- Foundation subsystems;
- Non-structural subsystems and their connections to the structure.

4.3 Analysis of the structure

Three basic methods can be used to quantify and distribute the seismic forces within a building's structure: the NBC 1995¹ equivalent static approach, spectrum analysis, and a dynamic analysis using time histories.

The equivalent static analysis is a simplified method used to compute lateral seismic forces based on a design spectrum having a probability of exceedance of 10% in 50 years. The method provides a base shear force referred to as minimum base shear, V , and distribution of forces over the height of the building.

For tall buildings with significant irregularities either in plan or elevation, or for buildings with setbacks or major discontinuities in stiffness or mass, the spectrum analysis will lead to a better distribution of the inertia forces. Spectrum analysis based on the design spectrum can be carried out according to the procedure provided by Commentary J in the Supplement to the NBC 1995¹.

Time history analysis requires a minimum of three ground motion time histories applicable to the location of the structure. The ground motion time histories can be obtained from recorded past activities or artificially generated using seismological models. The structural response parameters are calculated for each time history analysis and the maximum response is used for the assessment. NBC 1995¹ requires that the computed dynamic base shear be at least equal to the minimum base shear.

4.4 Evaluation of the seismic performance of building subsystems

The evaluation of the seismic response is based on the type of analysis, i.e., equivalent static, dynamic, linear or non-linear, and the results that the analysis yields. The engineer must also take into consideration the level of refinement used in analyzing the structure, i.e., whether the results were derived from a quick-check method or a 3-D finite element model. The assessment of the structure's seismic response is based on deformation and strength criteria. For stone-masonry structures, the following responses are needed for the assessment of seismic performance of the subsystems:

- Maximum lateral displacements;
- Maximum inter-storey drift;
- Maximum resultant forces;
- Maximum resultant stresses;
- Maximum ratio of shear stress to compressive stress.

4.5 Follow-up on-site inspection of accessible and critical subsystems

A follow-up on-site inspection is strongly recommended to check the as-built configuration of the existing subsystems and to identify possible deviations from original blueprints. If significant deviations are detected, the existing load path has to be identified. Structural discontinuities, weak connections, and lack of ties and anchors have to be identified. Horizontal or vertical irregularities that may influence the seismic response of the building have to be considered. For a reliable development of structural models and a better representation of the seismic capacity, the connections between existing components of the structure have to be inspected in accessible locations. Every detail affecting the capability of the structure to resist seismic loads has to be considered; this includes observed damage due to past earthquakes, poorly constructed elements, deterioration, etc.

In cases where relevant data on the strength of the materials and structural components is not available from previous investigations of similar buildings, such data may be obtained by *in-situ* testing of selected specimens. When additional data on the dynamic properties of the building (natural frequencies, mode shapes, damping ratios) is required, such data can be obtained by ambient or forced vibration tests. The experimental data of *in-situ* evaluation tests are useful for the calibration of mathematical models developed for the structural analysis.

Data on soil conditions and the foundations must be obtained from original drawings, on-site inspection, subsurface testing, or review of the data on the foundations of nearby buildings. If adequate geotechnical data are not available from previous testing, specific profile-type testing should be performed for building sites in areas with geologic hazards such as landslides or liquefaction.

4.6 Final report

The final report should detail all of the tasks undertaken for assessing the seismic capacity of the structure and the findings. The report should state clearly the source of information, the level of knowledge, the assumptions implied in the analysis of the structure, the type of analysis and model, the capacity of the structure, and the potential seismic risk.

The report should also provide different options of upgrading methods with associated cost estimates and degree of intrusion that can be used to mitigate the established seismic risk that is associated with the identified deficiencies. The degree of intrusion is usually the most critical factor in designing the upgrading method for heritage structures.

5 Seismic assessment criteria

As part of the guidelines development, performance criteria have been developed for most stone-masonry's structural and non-structural components. Only the acceptance criteria for walls, piers and towers are given in this paper.

5.1 Strength criteria

Sliding and rocking are two modes of failure that control the strength capacity of stone-masonry walls, piers and towers. The strength capacity of existing stonewalls and piers is the lesser of the following three (capacity) properties:

5.1.1 Sliding capacity

$$Q_{C,sl} = \mu(\sigma_0 - \sigma_{up})$$

Where μ is the coefficient of friction, σ_0 the average normal stress due to gravity loads, and σ_{up} the uplift stress produced by the vertical accelerations. The uplift stress value is to be computed using a vertical acceleration equal to 2/3 the horizontal ground acceleration.

5.1.2 Rocking capacity

$$Q_{C,r} = 0.9 \alpha \sigma_0 \frac{D}{h}$$

Where α is the factor for boundary conditions (equal to 0.5 for fixed-free wall or pier, or equal to 1.0 for fixed-fixed wall or pier), σ_0 the average vertical compressive stress in the wall or pier due to gravity

and vertical inertia forces, D the in-plane width of the masonry, and h the height of the wall or pier. A capacity reduction factor of 0.9 is added to compensate for toe crushing and out-of-plane deformation.

5.1.3 Shear capacity

Minimum of the two relationships:

$$Q_{C,sh} = 0.9 \tau_u$$

$$Q_{C,sh} = 0.9 \frac{f_t}{b} \sqrt{1 + \frac{\sigma_D}{f_t}}$$

where $f_t = \frac{-\sigma_D}{2} + \sqrt{\left(\frac{\sigma_D}{2}\right)^2 + (b\tau_u)^2}$

Here, σ_D is the compression vertical stress, b the shear stress distribution, τ_u the shear strength of the wall, and f_t the reference tensile strength of masonry. The strength acceptance criterion for the walls and piers is:

$$Q_D \leq k \cdot \min(Q_{C,sl}, Q_{C,r}, Q_{C,sh})$$

Where Q_D is equal to the demand horizontal shear force obtained from the seismic analysis divided by the net cross section of the subsystem.

5.2 Deformation criteria

The deformation acceptance criterion for walls and piers is

$$\Delta_D \leq k \cdot \Delta_C$$

Where Δ_D and Δ_C are, respectively, the demand deformation obtained from the seismic analysis and the deformation capacity. The latter is further defined as:

$$\Delta_C = 0.0004 h$$

for rubble stone-masonry, and

$$\Delta_C = 0.002 h$$

for good quality coursed stone-masonry. h is the storey height.

6 Case study

This case study which is included in Appendix A of the guidelines⁹, is based on an existing unreinforced thick stone-masonry tower constructed with rigid and flexible diaphragms.

6.1 Evaluation requirements

Prior to the evaluation of the seismic capacity of the tower, the site investigation and data collection need to be completed.

6.1.1 Site investigation and data collection

6.1.1.1 Building description

The selected tower, built between 1874 and 1878, is an unreinforced stone-masonry bearing-wall structure with nine floor systems and covered with a steel-frame roof. The lower five levels are attached to a building on three sides, while the remaining height is free standing. The total height of the tower is 81.55 m of which the roof is 32.6 m high. An overall view of elevation of the tower is shown in Figure 2. Its floor plan is basically rectangular with dimensions of approximately 9 m by 12 m. At two corners of the rectangle are octagonal turrets that are integrally with the tower.

A set of detailed geometric drawings of the tower is presented from Figure 3 to Figure 7 based on the original drawings and more recent on-site surveys. The drawings represent the plans of some typical floors. The indicated thickness of the walls were confirmed by means of direct measurements and by ground-penetrating radar.

The stone-masonry wall consists of two wythes. The inner layer is comprised of limestone blocks with an average height varying from 340 to 620 mm and a maximum measured length of 1800 mm. The outer layer or cladding is constructed of sandstone blocks with an average thickness of 100 mm to 300 mm. The thickness of the stone-walls is 1.8 m from the ground level (see Figure 3) to the third level, then changes to 1.5 m from the third level to the sixth (see Figures 4 and 5). Figure 5 shows the small openings and indentations along the stone-masonry walls between the sixth floor and the seventh floor; Figure 6, the seventh floor to the top of the stone-masonry, where the thickness of the stone-masonry walls is 1.4 m. Figure 6 also shows the size of the large openings between the seventh floor and the ninth floor.

The face of the interior stone-masonry is exposed above the fifth floor level. The walls consist of limestone blocks of nearly uniform height within one course. The sandstone cladding consists mostly of rectangular blocks attached to the limestone. At the top of the stone-masonry rises a solid clay brick wall of 2.94 m height. The base of the steel roof also rests on top of the stone-masonry but outside of clay brick walls (see Figure 7).

Figure 3 shows the second floor plan which includes the plan view of two octagonal stone turrets of the tower. The continuity of the octagon is interrupted by the openings of the doors and windows. Unlike the dimensions of the main walls of the tower, which remain almost unchanged with height, the diameter of the turrets becomes smaller from the bottom to the top. As shown in Figures 3 to 7, the outer diameter of the turret of 5.55 m at the second floor level becomes 5.08 m at the third floor, 4.32 m at the sixth floor, and finally 3.96 m at the ninth floor. The wall thickness of the turrets varies from 1.5 m at the first level to 1.2 m at the top of the stone-masonry. There are a number of openings in the turrets

which serve mainly as the entrance from the turrets to the main floors of the tower or as windows. Some typical openings and doors are shown in Figures 4 and 5.

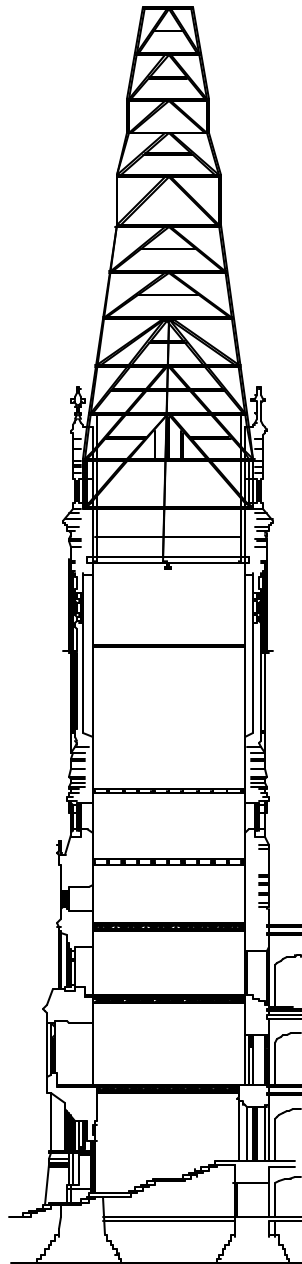

Figure 2 Elevation view of the unreinforced stone-masonry tower.

The first floor of the tower is a concrete diaphragm with a thickness of approximately 200 mm (see Figure 2). The three-floor diaphragms at the 3rd, 4th and 5th floor levels are brick arches spanning between steel joists. Above the fifth floor, wooden planks replace the brick and are resting on steel beam joists. The connections between the joists and the wall are not visible except at the ninth floor level. There the joists are essentially simply supported with each end extending 210 mm into the wall.

A large iron beam made of riveted plates (see Figure A1) is located under the ninth floor, and is simply supported on large stone corbels.

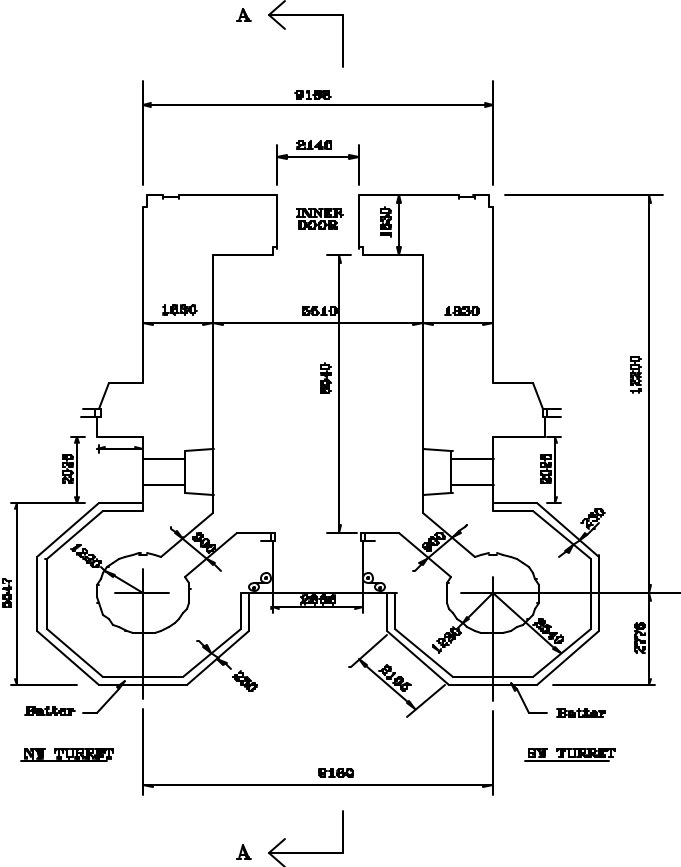

Figure 3 Third-floor plan view

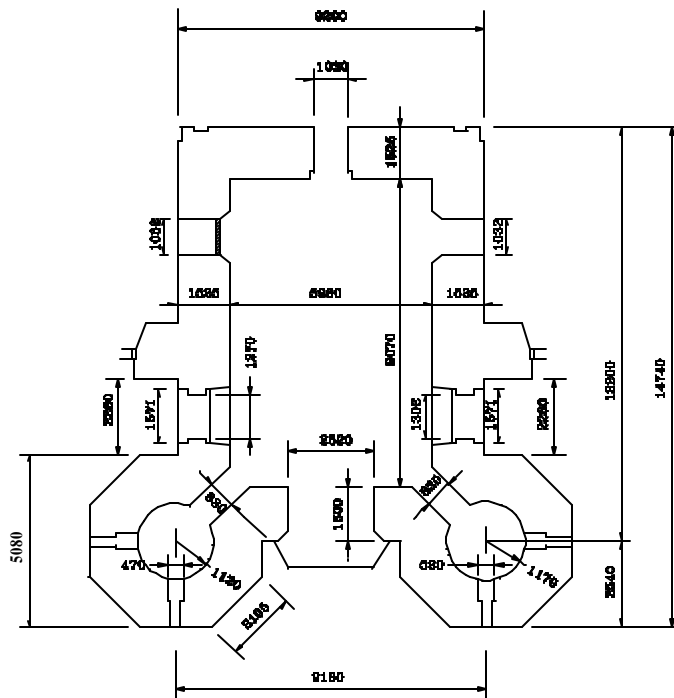

Figure 4 Fourth-floor plan view

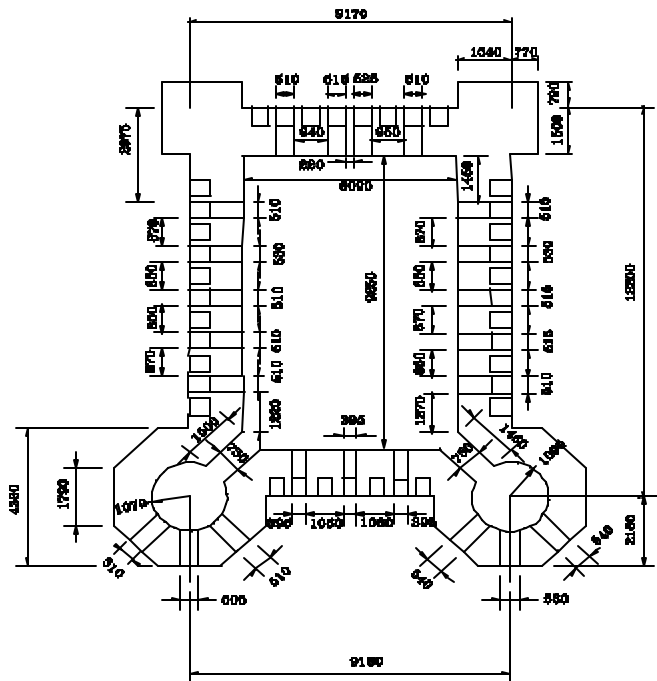

Figure 5 Seventh-floor plan view

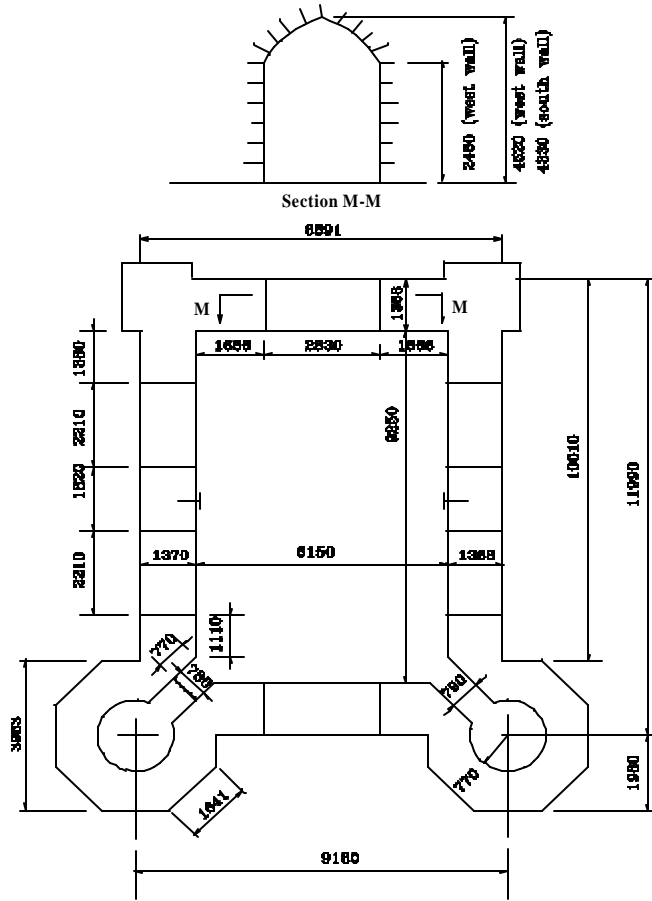

Figure 6 Ninth-floor plan view

The roof essentially consists of a space frame made of steel angles (100 by 100 by 10 mm or 75 by 75 by 10 mm), steel straps (65 by 10 mm), wood joists (150 by 105 mm) and wooden planks. The steel angles form a space frame structure (see Figure 2) with vertical steel straps (spacing 600 mm) bolted to the outside of the steel angles. Similarly, the vertical wood joist at 600-mm spacing are attached directly to the outside face of the straps. Finally, thin wooden planks are attached to the joists to form the sheathing.

The roof structure is connected to the stone-masonry tower at its corners. This is confirmed at one location where three connecting bolts are visible. Furthermore, as indicated in Figure 7, 10 steel rods, 38 mm in diameter tie down the roof to the steel joists on the ninth floor. The rods are in loose condition.

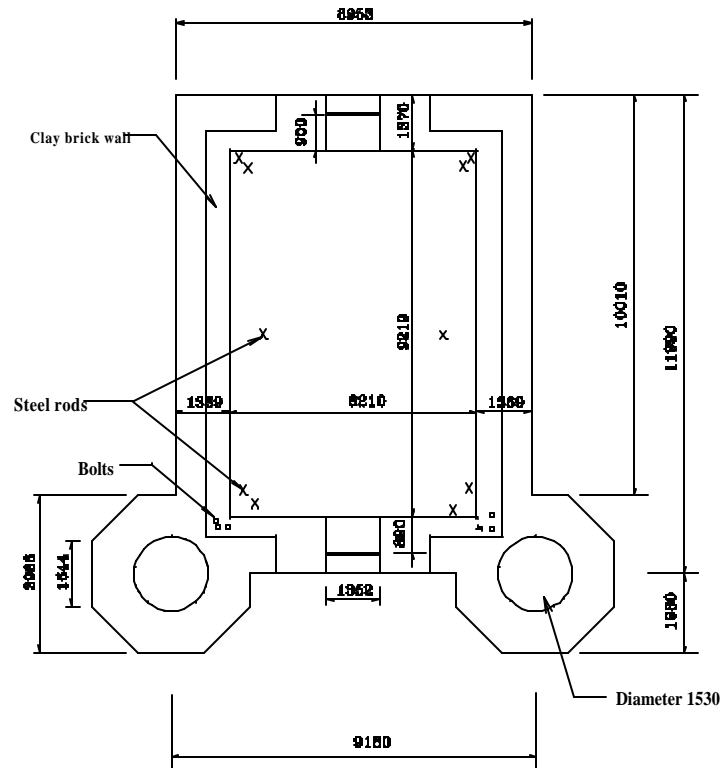

Figure 7 Eleventh- floor plan view

Comments

From the data collected, it is evident that the tower is constructed of good quality masonry and workmanship. Potential seismic deficiencies are observed in the anchoring condition of both the roof structure and wooden diaphragms, and in the stability of the cap of both turrets and chimneys.

6.1.1.2 Site survey

From the visual inspection, the tower is found generally in good condition and only minor distress signs can be observed. In the soffits arching over the top three window openings on the sixth floor, single vertical cracks are visible in the stones. These cracks do not appear to be extending right through the thickness of the stone. The mortar at the unoccupied part of the tower has a dry, chalky consistency due to water infiltration.

Some joints appear to have been re-pointed with Portland cement mortar. This intervention is likely to cause spalling of the mortar in the event of load redistribution. Only minor corrosion can be observed at the bottom of the steel roof frame. Straps coming out of the interior mortar joints in the main walls of the tower and at some other locations in the two west turrets of the tower have corroded.

Comments

From the site investigation, the condition of the stone-masonry is found to be generally good. Many of the interior and exterior mortar joints need re-pointing.

6.1.1.3 Past earthquake performance

Records of past seismic activities show that between 1900 and 1992, there were 26 earthquakes that had intensity III or greater on the Mercalli intensity scale, with magnitude V being the largest estimated intensity⁹.

Comments

From Table 2.1 of Reference 9 , one can deduce that structures subjected to seismic activities of magnitude less than VI on the Mercalli Intensity Scale are not likely to receive any damages even for masonry constructed of weak materials, poor mortar and poor workmanship. Therefore, very little information can be extracted from the past seismic performance of the tower.

6.1.1.4 Soil conditions

From the archives it was found that the foundation walls bear directly on bedrock with a step masonry footing as shown in Figure 2.

Comments

Value of 1.0 is therefore assigned to the foundation factor, F.

6.1.2 Identification of structural and non-structural subsystems of the structure

The structural subsystem of the tower consists of

- Two-wythe, load-bearing, unreinforced, thick masonry walls,
- two unreinforced stone-masonry turrets,
- rigid and flexible diaphragms, and
- a steel space frame roof structure.

The non-structural subsystems of the tower are the chimney and the caps of both the chimney and the turrets.

6.2 Analysis of the structure

The analysis of the structure begins with the conventional calculation of lateral forces.

Weight

The total weight of the tower, W, is 90,400 kN.

Natural period

The natural period of the tower is obtained using four different methods presented in the guidelines to illustrate the benefits of detailed analysis and of the dynamic measurements. The results are summarised in Table 2. It should be noted that the computed first mode of vibration by the Rayleigh method and the eigenvalue analysis have been calibrated to the measured one. The corresponding material properties are given in Table 3.

Table 2 Natural period of the tower

Mode No.	Period (s)			
	Empirical code relation	Rayleigh's approximation	Eigenvalue analysis - FEA	Vibration measurements
1 - NS lateral	1.15	0.57	0.57	0.57
2 - EW lateral	1.15	0.48	0.47	0.47
3 - Rotational		0.32	0.32	0.36

Table 3 Material properties adopted for the calibration of the tower's dynamic properties

Material	Method of analysis			
	Rayleigh's approximation		Eigenvalue analysis - FEA	
	Young modulus (MPa)	Mass density (kg / m ³)	Young modulus (MPa)	Mass density (kg / m ³)
Limestone	6	2716	3.5	2716
Sandstone	6	2716	3.5	2600
Brick	28	1800	28.0	1800
Steel	200	7800	200.0	7800
Copper			110.0	8900
Wood			7.0	450

1. Empirical relation suggested by NBC 1995, i.e.

$$T = \frac{0.09h}{\sqrt{D}} \quad (6.2)$$

2. Rayleigh approximation method

$$T = 2\pi \sqrt{\frac{\sum_{i=1}^n W_i \delta_i^2}{g \times \sum_{i=1}^n W_i \delta_i}} \quad (6.3)$$

A simple model is required to approximate the period of the tower using Rayleigh's approximation method. The model, shown in Figure 8, consists of five lumped masses, each with three degrees of freedom, two out-of-plane translations and one rotation resulting in a total of 15 degrees of freedom.

The simplifying assumptions employed to model the tower are as follow: First, the stiffness of the steel frame was approximated by idealising the roof as a triangular truss structure pin-ended at the top and the bottom. The stiffness of both the stone and brick masonry walls was computed based on their sectional dimensions. Equation 6.26 provides the relation used in computing the stiffness.

3. Eigenvalue analysis

A finite element model of the tower shown in Figure 9 was generated to compute the natural period. The model consists of 7073 elements and 6907 nodes.

4. Vibration tests

On-site ambient vibration tests were conducted. The first three modes and their associated mode shapes are presented in Figures 10 to 12. A general description of the modes along with the values corresponding to each mode is presented in Table 4.

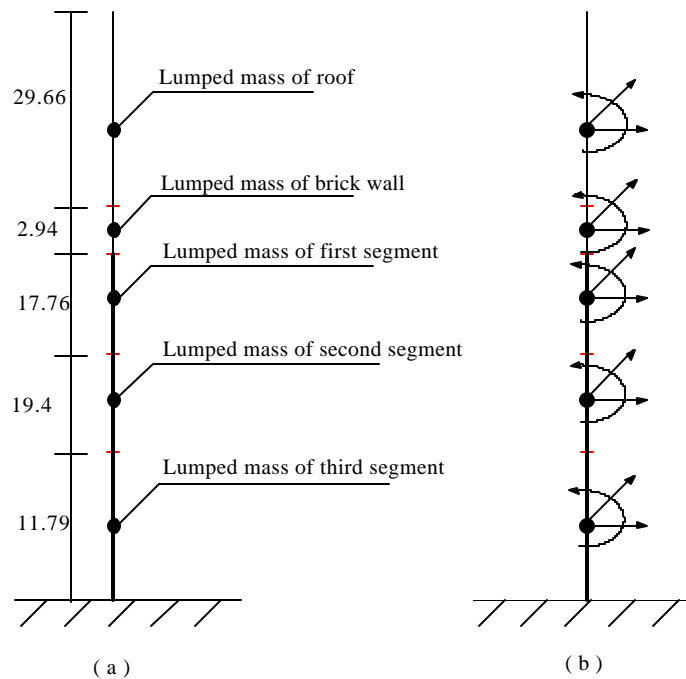

Figure 8 Simple model of the tower:(a) Lumped masses (b) Degrees of freedom



Figure 9 Finite element model of the tower

Table 4 Natural periods and mode shapes obtained from the ambient vibration test

Mode Number	Period (s)	Description of mode shapes
1	0.56	<ul style="list-style-type: none"> • North-South (N-S) lateral • Large relative motion of steel roof in the N-S direction • Significant motion at the base of the steel roof relative to the top of the stone-masonry
2	0.47	<ul style="list-style-type: none"> • East-West (E-W) lateral • Discontinuity at the base of the steel roof is more pronounced in the E-W direction
3	0.36	<ul style="list-style-type: none"> • Rotational about Z-axis • Twisting and lateral motion, and expansion of the base of the steel roof

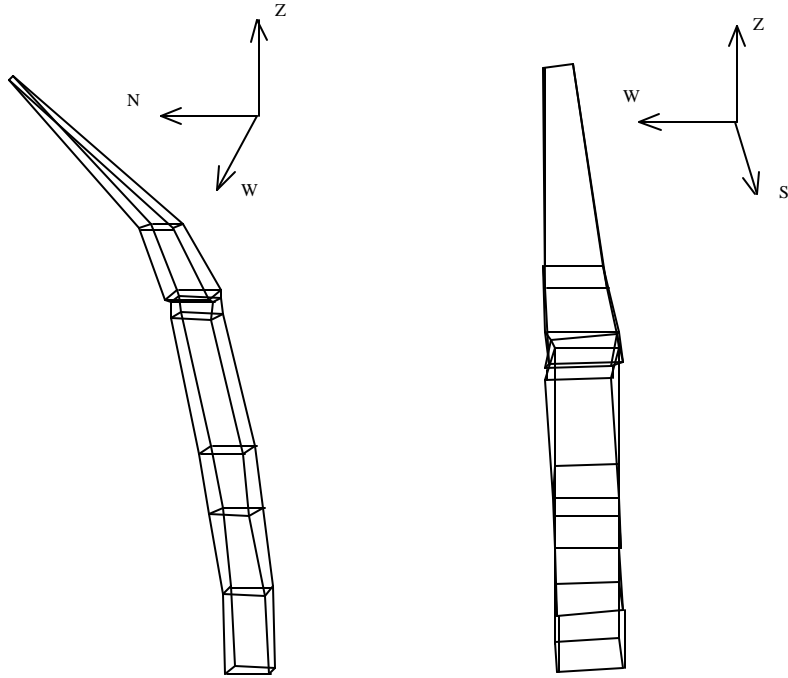

Figure 10 First lateral mode of vibration obtained from the ambient vibration test

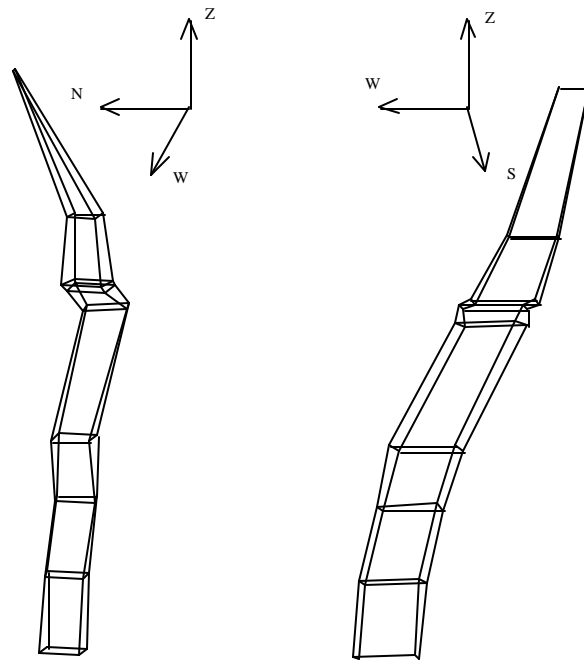

Figure 11 Second lateral mode of vibration obtained from the ambient vibration test

Comments

- a) It should be noted that although a significant difference exists between measured values and the code value, NBC 95 requires that the computed total base shear be equal to the equivalent static base shear computed based on the empirical relation. In general, this requirement tends to penalize stone-masonry structures. For this case study, the code empirical relation yields lower total base shear but requires 9% of the base shear to be concentrated at the top.
- b) The vibration measurements have provided the dynamic properties of the tower, a calibration to the mathematical models, and insight into potential weakness in the roof anchoring conditions.
- c) The four methods of determining the natural period of a structure is given to illustrate the potential differences in the empirical relations in comparison to more representative values — measured values.

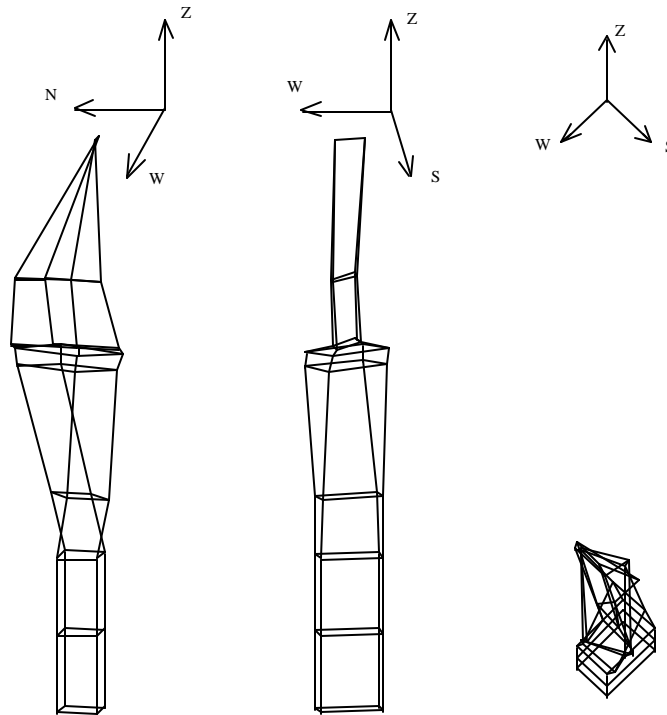

Figure 12 Third mode of vibration (torsional) obtained from the ambient vibration test

Base shear

Using the data collected, the base shear can be calculated based on

$$V = 0.6V_e / R$$

where R , the force modification factor is equal to 1 for unreinforced masonry, and V_e , the equivalent lateral base shear representing the elastic response is given by

$$V_e = v \cdot S \cdot I \cdot F \cdot W$$

where:

T =	1.15 s (Eq. 6.2)	0.57 s (Measured value)
v =	0.1	0.1
I =	1.0	1.0
S =	1.40	2
F =	1.0	1.0
W =	90.4 MN	90.4 MN
$V_e =$	12.66 MN	18.08 MN

Total base shear:

V =	7.6 MN	10.8 MN
-----	--------	---------

From the measured vibration properties of the tower, the computed base shear was found to be greater than the one computed using the code empirical relationship. For this case study, the seismic demand requirement of the tower is assumed equal to 10.8 MN. The base shear is distributed along the height of the building in accordance to Equation 3.3. The results are given in Table 5.

Table 5 Lateral inertia force along the height and associated weights

Elevation (m)	Weight (kN)	Lateral seismic force (kN)
81.55		
78.50	16.06	7.13
75.45	20.85	8.90
73.77	25.24	10.44
70.76	28.83	11.55
67.51	40.10	15.37
64.46	41.00	15.00
61.36	47.88	16.70
58.21	59.06	19.58
55.06	52.57	16.51
51.89	420.78	124.76
48.95	1607.00	449.24
46.57	3805.00	1007.58
40.79	7458.10	1806.22
31.19	10946.10	2184.25
26.47	6275.50	1003.04
22.40	10242.80	1387.55
17.63	9412.20	1044.37
11.79	10250.30	835.72
6.71	9761.90	500.38
2.87	11311.70	300.39
0.00	8618.50	68.67
Total	90441.47	10833.33

Comments

- a) The lateral-force distribution presented for this analysis did not account for the flexible diaphragms which are present at the upper portion of the tower. The cross-section geometry of the tower and the considerable thickness of the stone-masonry walls are believed to provide adequate stiffness to collect the inertia forces and transmit them to the shear walls without the presence of rigid diaphragms.
- b) The seismic capacity/demand requirements for the steel-roof structure and the diaphragms are not part of this assessment. NRC's seismic guidelines provide the necessary steps for assessing the seismic capacity of the steel roof and the diaphragms.

Lateral displacement

The lateral displacements along the height of the tower are computed using the lumped mass model and the equivalent static load of Table 6.

Table 6 Tower's lateral displacement and drift at various heights

Elevation (m)	E-W direction		N-S direction	
	Displacement (mm)	Drift	Displacement (mm)	Drift
6.71	0.06	0.0000	0.22	0.0000
26.47	3.60	0.0002	7.60	0.0004
48.95	24.90	0.0011	40.43	0.0018

Shear stress

The normal and shear stresses due to inertia forces and weight of the structure are summarised in Tables 7 and 8 for the E-W and N-S directions, respectively.

Table 7 Shear and normal stress at various heights due to E-W ground excitation

Elevation (m)	Stress (MPa)		
	Shear	Normal	Shear/Normal
2.87	0.31	2.05	0.15
6.71	0.31	2.07	0.15
11.79	0.30	2.01	0.15
17.63	0.30	1.80	0.17
22.40	0.28	1.35	0.21
26.47	0.30	0.97	0.31
31.19	0.29	1.12	0.26
40.79	0.52	0.75	0.69
46.57	0.32	0.39	0.82
48.95	0.09	0.13	0.69

Table 8 Shear and normal stress at various heights due to N-S ground excitations

Elevation (m)	Stress (MPa)		
	Shear	Normal	Shear/Normal
2.87	1.10	1.95	0.56
6.71	1.21	2.25	0.54
11.79	1.19	2.42	0.49
17.63	1.19	2.24	0.53
22.40	1.09	1.75	0.62
26.47	1.00	1.15	0.87
31.19	0.88	1.20	0.73
40.79	3.02	0.78	3.87
46.57	1.76	0.41	4.29
48.95	0.27	0.14	1.93

6.3 Evaluation of the seismic performance of the building subsystems

The first step of the evaluation begins with the evaluation statements of the structural checklist.

The structural checklist provided in these guidelines (see Table 2.3 of Reference 9) is a SUPPLEMENT TO the Evaluation Statements of NRC'S SEISMIC GUIDELINES. Therefore, the evaluating engineer still needs to answer NRC's evaluation statements (not presented here).

6.3.1 Structural checklist

The following is a completed Structural Checklist for the tower which covers only the stone-masonry part of the tower. Each of the evaluation statements has been marked compliant (C), non compliant (NC) or not applicable (N/A). Compliant statements identify issues that are acceptable according to the criteria of these guidelines, while non-compliant statements identify issues that require further investigation. In addition, an explanation of the evaluation process is included in italics after each evaluation statement.

1. General

C NC N/A LOAD PATH: The structure contains one complete load path for seismic force effects from any horizontal direction that serves to transfer the inertial forces from the mass to the foundation (Sec. 2.2).

The structure contains a complete load path.

C NC N/A WEAK STOREY: The strength of the lateral-force-resisting system in any storey is not less than 80% of the strength in an adjacent storey above or below (Sec. 2.2).

The thickness and composition of the stone-masonry walls of the

tower are minimally altered along the height.

- C NC N/A SOFT STOREY: The stiffness of the lateral-force-resisting system in any storey is not less than 70% of the stiffness in an adjacent storey above or below or less than 80% of the average stiffness of the three stories above or below (Sec. 2.2).

The thickness and composition of the stone-masonry walls of the tower are minimally altered along the height.

- C NC N/A GEOMETRY: There is no change in horizontal dimension of the lateral-force-resisting system of more than 30% in a storey relative to adjacent stories, excluding one-storey penthouses (Sec. 2.2).

The tower is rectangular in plan.

- C NC N/A VERTICAL DISCONTINUITIES: All vertical elements in the lateral-force-resisting system are continuous to the foundation (Sec. 2.2).

All shear walls are continuous to the foundation.

- C NC N/A MASS: There is no change in effective mass more than 50% from one storey to the next (Sec. 2.2).

The thickness and composition of the stone-masonry walls of the tower are minimally altered along the height.

- C NC N/A TORSION: The distance between the storey centre of mass and the storey centre of rigidity is less than 20% of the building width in either plan dimension (Sec. 2.2).

The maximum distance between the storey centre of rigidity and the centre of mass is approximately 1.3 m which is 9% of the plan dimension of the building in the E-W direction.

- C NC N/A MASONRY UNITS: There is no visible deterioration of stone-masonry units (Sec. 2.2.2).

There is no visible deterioration of the stone-masonry units.

- C NC N/A MASONRY JOINTS: The mortar is not easily scraped away from the joints by hand with a metal tool, and there are no areas of eroded mortar (Sec. 2.2.2).

In general, the mortar joint is thin and is not easily scraped away by hand. There are no significant areas of eroded mortar.

- C NC N/A UNREINFORCED STONE-MASONRY WALL CRACKS: There are no existing diagonal cracks in wall elements greater than 1 mm, or out-of-plane offsets in the bed joint greater than 5 mm (Sec. 2.2 and 2.3.1).

There are no diagonal cracks of considerable length or out-of-plane

offsets in the bed joint.

- C NC N/A UNREINFORCED STONE-MASONRY DOMES, ARCHES, etc.,
CRACKS: There are no existing vertical or horizontal cracks in dome and arch structural subsystems greater than 1 mm, or out-of-plane offsets in the bed joint greater than 5 mm (Sec. 2.3.3 and 2.3.4).

There are no diagonal cracks of considerable length or out-of-plane offsets in the bed joint of the arches above opening.

- C NC N/A MASONRY LAY-UP: filled collar joints of multi wythe masonry walls have negligible voids (Sec. 2.2).

The spacing between the inner and outer wythe have no voids.

2. LATERAL FORCE RESISTING SYSTEM

- C NC N/A REDUNDANCY: The number of lines of shear walls in each principal direction is greater than or equal to 2 (Sec. 2.2).

There are two shear walls in each direction.

- C NC N/A SHEAR STRESS CHECK: The shear stress in the unreinforced masonry shear walls, calculated using the Quick Check procedure of Section 3.4, is less than 0.1 MPa for rubble construction and less than $0.5 \sigma_D$ for coursed stone-masonry (Sec. 3.4).

From Table 7 and 8, the shear stress is found greater than 0.5 times the normal stress.

3. DRIFT

- C NC N/A DRIFT: The drift ratio for stone-masonry walls is limited to 0.0015 for good quality coursed construction and 0.0003 for rubble construction (Sec. 2.3.1 and 2.4.1).

The walls are of good quality coursed construction. The EW and NS drifts are 0.0011 and 0.0018. The NS drift is slightly greater than 0.0015.

- C NC N/A PROPORTIONS: The height-to-thickness ratio of the shear walls of coursed stone-masonry at each storey is less than the following (Sec. 2.3.1, 2.3.6 and 2.4):

	Seismic Zone	
	<u>High</u>	<u>Moderate to low</u>
Top storey of multi-storey building	9	14
First storey of multi-storey building	15	18
All other conditions	13	16

The tower is located in a moderate to low seismic region

The height to thickness ratio of the shear walls is

First storey : $2.87 / 1.80 = 1.6 < 18$

top storey : $2.94 / 0.63 = 4.7 < 14$

Intermediate storey : $9.60 / 1.38 = 7.4 < 16$

Total unsupported stone-masonry wall = $22.49 / 1.5 = 15.0 < 16$

4. CONNECTIONS

- C NC N/A WALL ANCHORAGE: Exterior stone-masonry walls are anchored for out-of-plane forces at each diaphragm level with steel anchors or straps that are developed into the diaphragm (Sec. 2.2.4).

There is no evidence of anchorage between the floors and the diaphragm from the 6th floor up to the 10th floor. However, given the walls aspect ratio of 6, no problems are anticipated.

- C NC N/A ANCHOR SPACING: Exterior masonry walls are anchored to the floor and roof systems at a maximum spacing of 1 m (Sec. 2.3.1).

There are no anchors. The tower's walls have adequate stiffness and strength to transfer the horizontal load, i.e., it is OK.

- C NC N/A TRANSFER TO SHEAR WALLS: Diaphragms are reinforced and connected for transfer of loads to the shear walls (Sec. 2.2.3).

Diaphragms from the 6th floor are flexible and cannot transfer any horizontal load. However, the tower's walls have adequate stiffness and strength to transfer the horizontal load, i.e., it is OK.

- C NC N/A DOMES, ARCHES, etc./COLUMN CONNECTION: There is a positive connection between the domes, arches, and all other stone-masonry structural systems and the column support (Sec. 2.3.3, 2.3.4 and 2.3.5).

The arch above the openings is keyed in.

5. DIAPHRAGMS

This section is not applicable for flexible diaphragms from the 6th floor up to the roof.

- C NC N/A PLAN IRREGULARITIES: There is tensile capacity to develop the strength of the diaphragm at re-entrant corners or other locations of plan irregularities (Sec. 2.2.3).

The walls are thick.

- C NC N/A DIAPHRAGM CONTINUITY: The diaphragms are not composed of split-level floors (Sec. 2.2.3).

There are no split levels.

C NC N/A CROSS TIES: There are continuous cross ties between diaphragm chords (Sec. 2.2.3).

Since it is a single structure with very thick walls, meeting this requirements is not necessary.

C NC N/A ROOF CHORD CONTINUITY: All chord elements are continuous, regardless of changes in roof elevation (Sec. 2.2.3).

6. STONE-MASONRY BEARING WALLS

C NC N/A UNREINFORCED STONE-MASONRY: Unreinforced rubble stone-masonry is braced at a spacing of 3 m or less in regions of moderate seismicity, and 1.5 m in regions of high seismicity (Sec. 2.3.1).

The walls are not braced; however, this requirement is intended for rubble type construction.

7. PARAPETS, CORNICES, ORNAMENTATION AND APPENDAGES

C NC N/A URM PARAPETS: There are no laterally unsupported, unreinforced stone-masonry parapets or cornices above the highest anchorage level with height-to-thickness ratios greater than 1.5 in regions of high seismicity and 2.5 in regions of moderate or low seismicity (Sec. 2.4.3).

The turrets cap does not meet the requirements.

8. MASONRY CHIMNEYS

C NC N/A URM: Unreinforced stone-masonry chimneys do not extend above the roof surface more than twice the least dimension of the chimney (Sec. 2.4.4).

C NC N/A MASONRY: Masonry chimneys are anchored to the floor and roof (Sec. 2.4.4).

9. STAIRS

C NC N/A URM WALLS: Walls around stair enclosures do not consist of unreinforced stone-masonry (Sec. 2.3.1).

One of the turrets also provides the stair enclosure which is constructed of unreinforced stone-masonry. However, the turret has a small diameter with thick walls and is well keyed-in to the walls of the tower. Thus it is very unlikely to fall out.

6.3.2 Performance assessment

The following potential deficiencies were identified by the evaluation statement of the structural checklist:

- shear stress of the masonry walls
- N-S drift of the masonry walls

- connections between the walls and the diaphragms
- bracing of walls
- diaphragms
- stability of chimney and cap of turrets.

Further evaluation needs to be carried out for the items identified with potential deficiencies.

Shear stress

The shear capacity is the minimum of the two relations given by Eqs. 7.7 and 7.8. The corresponding knowledge factor is taken as 1.0. This yields

$$Q_{C,sh} = 1.0 \times 0.9 \times 0.65 \times \sigma_D = 0.59 \sigma_D$$

The demand requirements are given in Tables 7 and 8, respectively, for the E-W and N-S ground excitation.

For the E-W direction,

$$Q_{D,sh} = 0.6 \times 0.82 \times \sigma_D = 0.49 \sigma_D < 0.59 \sigma_D \quad \text{Compliant}$$

For the N-S direction,

$$Q_{D,sh} = 0.6 \times 3.87 \times \sigma_D = 2.32 \sigma_D > 0.59 \sigma_D \quad \text{Not Compliant}$$

$$Q_{D,sh} = 0.6 \times 4.29 \times \sigma_D = 2.57 \sigma_D > 0.59 \sigma_D \quad \text{Not Compliant}$$

$$Q_{D,sh} = 0.6 \times 1.93 \times \sigma_D = 21.16 \sigma_D > 0.59 \sigma_D \quad \text{Not Compliant}$$

From an elevation of 40.79 to 48.95 m, the shear capacity of the stone-masonry walls is deficient in resisting inertia forces in the NS direction.

Drift

The deformation acceptance criteria for walls, piers and towers are given by Eqs. 7.10 and 7.11. The corresponding knowledge factor is taken as 1.0. For good-quality coursed stone-masonry structure, this yields

$$\Delta_D = 0.0018 < k \Delta_C = 1.0 \times 0.002 = 0.002 \quad \text{Compliant}$$

The demand requirements are given in Table 6.

Connections

The anchoring conditions between the exterior walls and the rigid diaphragms for the first five floors is not known and requires further explorations. At the upper portion of the tower, the diaphragms are flexible and do not contribute to the stability of the tower. Adequate anchorage and strength must be ensured, however, to mitigate any potential threat to life. The procedure for assessing the diaphragms requirements is given by NRC's seismic guidelines.

Bracing

The guidelines require that unreinforced stone-masonry be braced at a spacing of equal to or less than 3 m in regions of low and moderate seismicity to mitigate potential brittle failures. This requirement is more applicable to rubble type of construction and is considered too severe for this case study.

Diaphragms

The capacity of the diaphragms can be checked using the requirements of NRC's seismic guidelines. Their capacity will, however, not affect the stability of the tower.

Stability of chimney and cap of turrets

The deficiencies identified for the non-structural subsystems need to be mitigated.

6.4 Follow-up-on-site inspection

Subsequent to the above evaluation, a follow-up site investigation would be required to check the anchorage conditions of the exterior walls and of the non-structural subsystems.

6.5 Final evaluation and report

The second evaluation process revealed that

1. the shear capacity of the walls between the 7th and 9th floor does not meet the required demand,
2. the connections between the exterior stone-masonry walls and the diaphragms are not adequate, and
3. the anchoring conditions for the chimney and the turrets' cap do not meet the requirements of the guidelines.

Depending on the cost and extent of the intervention required to mitigate the potential shear deficiencies and the heritage value of the structure, advanced analysis such as the finite element method may be warranted.

The identified deficiencies, the connections between the diaphragms and the exterior walls as well as the anchoring of the non-structural sub-system need to be mitigated.

7 Conclusion

To meet the pressing need for guidelines on the seismic risk reduction of stone-masonry structures, Public Works & Government Services Canada have developed a series of two technical documents: one on assessment and the other one on upgrading. The purpose of developing these documents is to

provide technically sound risk management tools for the seismic assessment and upgrading of stone-masonry structures. This paper provided a brief description of parts of the guidelines for the seismic assessment of stone-masonry structures.

8 Acknowledgment

Financial support for the development of the guidelines was provided by Public Works & Government Services Canada through its Technology Development and Transfer Program. The authors wish to acknowledge the following individuals for their critical review of the guidelines and their comments: D. Allen, L. Binda, M. Bruneau, C.R. Constantinescu, L. Fontaine, M. Green, M. Harajli, K. Ibrahim, A.H.P. Maurenbrecher, C. Modena, J.H. Rainer, D.E. Sporleder, S. Thomasen, M. Tomazevic, and C. Vollan.

References

1. National Research Council of Canada, 1995. *National Building Code of Canada*, Ottawa, Ontario, Canada.
2. Chidiac, S.E., Rainer, J.H., Maurenbrecher, A.H.P., and Allen, D.E., 1995. *Seismic evaluation of the Mackenzie Tower as a basis for the evaluation of the Parliament Buildings*, NRC Report No. A8006.2, National Research Council Canada, Ottawa, Canada.
3. Comité National d'URSS de l'Icomos., 1989. *Le sauvetage du patrimoine architectural de l'Arménie*, Icomos Information, No. 2, 11-22.
4. Erdik, M., 1990. *The earthquake performance of rural stone-masonry buildings in Turkey*, and, *Earthquake damage evaluation vulnerability analysis of building structures*, A. Koridze (ed.) INEEC Series of Engineering Aspects of Earthquake Phenomena, V3, Omega Scientific.
5. Pomonis, A., 1990. *The October 1988 Eia Prefecture earthquake (SW Greece): Seismic environment, building types and change patterns*, Disasters, Vol. 13, No. 2, 101-117.
6. National Research Council of Canada, 1993. *Guidelines for Seismic Evaluation of Existing Buildings*, Ottawa, Ontario, Canada.
7. National Research Council of Canada, 1993. *Guidelines for Upgrading of Building Structures*, Ottawa, Ontario, Canada.
8. Federal Emergency Management Agency, 1997. *Handbook for the Seismic Evaluation of Existing Buildings: A Pre-standard (90%)*, prepared by American Society of Civil Engineers, Prepared for Federal Emergency Management Agency, Report FEMA-178, Washington, D.C.
9. Public Works & Government Services Canada, 2000. *Guidelines for Seismic Assessment of Stone-Masonry Structures*, Hull, Quebec, Canada.
10. Public Works & Government Services Canada, 2000. *Guidelines for Seismic Upgrade of Stone-Masonry Structures*, Hull, Quebec, Canada.