

SENSEable CITY GUIDE
TO **RIO DE JANEIRO**



RIO DE JANEIRO
SENSEable CITY GUIDE

COPYRIGHT

©2011 by SENSEable City Lab.
All rights reserved.
Cambridge, Massachusetts.

PRODUCED BY

The SENSEable City Lab, The Massachusetts
Institute of Technology

WITH SUPPORT FROM:

GE

PRODUCTION MANAGER

Prudence Robinson

EDITED BY

Prudence Robinson
Jennifer Dunnam
Adam Pruden

AUTHORS

Bárbara Ribes Giner
Elijah Hutchinson
Eric Baczuk
Okhyun Kim
Otto C L Ng

CONTRIBUTION FROM

Catilin M. Zacharias
Lindsey Hoshaw
Eugene Lee

GRAPHIC DESIGN

studio FM milano

PRINTED BY

Puritan Press, Inc.

PUBLISHED BY

SA+P Press

ISBN

9780979477485

SENSEable City Laboratory
Massachusetts Institute of Technology
Building 9 - 209 | 77 Massachusetts Av.
Cambridge, Massachusetts | 02139 USA
T++ 1-617-2537926 | F++ 1-617-2588081
senseable.mit.edu

RIO DE JANEIRO

SENSEable City Guide

R1 /

Growing Connections
by Bárbara Ribes Giner

R2 /

WaterReader
by Elijah Hutchinson

R3 /

The Lula Project
by Eric Baczuk

R4 /

The Sensing Nose
by Okhyun Kim

R5 /

Beach Fashionsense
Rio 2016
by Otto C L Ng

SCG WORLD MAP

Welcome to the SENSEable City Lab - a cutting-edge multidisciplinary research group that studies the interface between cities, people, and technologies and investigates how the ubiquity of digital devices and the various telecommunication networks that augment our cities, are impacting urban living. With an overall goal of anticipating future trends, we bring together researchers from over a dozen academic disciplines to work on groundbreaking ideas and innovative real-world demonstrations.

Each academic year, the SENSEable City Lab invites students at the Massachusetts Institute of Technology to participate in the Digital City Design Workshop. The workshop seeks to provide pragmatic, technological solutions that address a key concern of urban living. The SENSEable City Guide series showcases this research which is undertaken in partnership with cities from across the world.



SENSEable CITY LAB - MIT - BOSTON

SCL1 / The SENSEable City Laboratory Fact Sheet

SCL2 / The SENSEable City as a Cybernetic Mechanism of Sensing, Analysis and Actuation

SCL3 / The SENSEable City and Mechanisms of [Crowd-]Sensing

SCL4 / The SENSEable City and Mechanisms of Actuation: Networks and Neo-Cyborgs

SCL5 / The SENSEable City and Mechanisms of Data Analysis and Computation



RIO DE JANEIRO

R1 / Growing Connections

R2 / WaterReader

R3 / The Lula Project

R4 / The Sensing Nose

R5 / Beach Fashionsense Rio 2016

RIO DE JANEIRO

Introduction

by Eric Baczuk

As of 2010, more than half of humanity resides in the dense, urban agglomerations we call cities. This is merely a signpost of the largest rural to urban migration ever witnessed in the history of humanity - and this trend is set to accelerate in the coming years. Such rapid-urbanization places great strain on the infrastructure of cities. The adequate provision of clean water, sanitation and basic power, has become a challenge faced by new and existing cities alike. Today, minds from across government, industry and academia are giving a great deal of attention to urban infrastructure, and understanding how these services could be re-invented to keep up with this massive influx. Unfortunately, for a growing number of cities around the world, civic infrastructure has already been outpaced by this flood of urban migrants. This has led to a steep rise in informal settlements at the peripheries of many of the world's great cities. Over the next 20 years, the population of the world's residents living in informal communities is set to double, totalling over 2 billion people by 2030. How are cities to cope with this new urban condition? If slums are inevitable, what can be done to raise the standards of health and quality of life in these areas? Devising how these regions are to move forward in a socially inclusive and environmentally sustainable manner will serve as one of the greatest challenges of our generation.

The sprawling slums, or Favelas of Rio de Janeiro are perhaps the world's 'poster child for informal settlements'. Starting in the 1880's, freed and escaped African slaves - far too poor to acquire land of their own - began to appropriate the hillsides outside of Rio. Over generations,

this phenomenon of self-built and self-organized communities - made of corrugated steel shacks and dirt pathways - flourished. However, despite their sizeable populations, social stigmas have prevented these regions from receiving formal recognition by the city or its authorities. Despite government efforts at slum clearance and relocation in the 1950s and 60s, and slum rehabilitation throughout the 70s and 80s, the favelas have proved resilient and remain a fixture of Rio's landscape. Today, around a quarter of the population of Rio de Janeiro lives in favelas. Coming to terms with the reality of Favelas, state and federal governments have recently joined forces to improve living standards in a number of informal communities around Rio. Since the early 1990's, State-funded programs such as Favela-Barrio (translates to Slum-Neighborhood) have made great strides towards improving the quality of life in these areas. Through intensive capital expenditure and invasive construction procedures, many favelas have been improved, equipping them with modern sanitation, electrical power and drinking water supplies. However, the progress of these programs are slow and costly, both to the government and to the communities in which they improve. Despite the physical upgrading, glaring disparities continue to exist between the "hills" and the "pavement" across a number of metrics, including income, education, health and life expectancy. Therefore, many challenges are still present: What could be done to help overcome these social stigmas? How can these neglected communities be better served? Might there be cheaper, quicker alternatives to conventional "upgrading"? What can be done to

reduce the inequalities between the formal and informal city?

Faced with these challenge, GE (General Electric) partnered with the SENSEable Cities Workshop to explore how distributed networks and pervasive technologies might be employed to augment or even create a new ground-up, urban infrastructure in favelas. They were also interested in how technology might be used to break down the social barriers that exist between the "hills" and the "pavement," to create a more unified city. As Rio de Janeiro will be hosting the 2014 World Cup of Soccer, and the Olympics in 2016, GE had a great interest in developing innovations in Rio that could be showcased to the world. During their trip to Rio de Janeiro, the team explored many aspects of the formal and informal city. Staying near the beach in Copacabana, they sampled Rio's famous beach culture before visiting both "upgraded" (Vidigal) and "non-upgraded" (Rocinha) favelas, recording their experiences of each, interacting with locals and documenting social activities and built environments. This broad range of urban conditions and character gave the students an introduction to the complexity and diversity that defines Rio de Janeiro. Finally, through their discussions with GE and local researchers, they learned what kinds of data systems could be most helpful in improving public access to physical infrastructure and promoting public health in these communities. With this information, the team developed designs that achieved each of the goals of their brief. Bárbara Ribes Giner designed "Growing Connections," a self-organized digital marketplace that would link micro-producers of urban

agriculture with local consumers. Elijah Hutchinson developed the “Water Reader,” a on-tap filter and reporting device that ensures users that the water they receive from their tap is safe for drinking. Eric Baczuk invented “The Lula Project” a fleet of interactive, autonomously controlled sensing robots that would patrol Rio’s beaches, reporting on water pollution levels, and inciting political action for issues of waste-water treatment. Okhyun Kim proposed “The Sensing Nose,” a sensor-embedded fan that promotes indoor air quality in favela homes, while alerting residents of possible health risks. Otto Ng designed “Beach Fashionsense Rio 2016,” a line of sensor-equipped beachwear that uses a color-changing fabric to advise its users on potential water quality and UV risks.

By focusing on a diverse range of issues and settings, the team has designed a broad range of innovative solutions for tackling the complex environmental and social challenges that face Rio de Janeiro today. Present in each of these proposals is a strong connection to personal choice and the concept of micro-scale behavior, scaling up to inspire far-reaching affect, and improving the experience and social amenities of the Cuidade Mahrvelosa. This suite of proposals aims to inspire the city beyond the Olympics, towards a new future as Rio de Janeiro reinvents itself to secure a place among the world’s most progressive and competitive cities.

R1

Growing Connections

by Bárbara Ribes Giner



PROJECT DESCRIPTION

The main focus of this project is to propose solutions to pressing issues for residents of Rio de Janeiro's favelas. Rio is one of the World's most famous cities. A prominent city within Brazil and a part of a rapidly developing economy of the BRIC countries (Brazil, Russia, India and China). The city has been selected as the host city for the 2014 World Cup, and also as the host for the 2016 Summer Olympics.

The city of Rio de Janeiro has a population of around 6 million people, with around 11 million people in total residing in the Southeast region. Water availability, quality, and pollution are some of the most serious issues facing the populace; especially the inhabitants of Rio's large favelas. These slum and shanty towns are recognizable by the crowded structures built one on top of the other, climbing into the hills surrounding the city. The total number of favelas in Rio alone is nearly 1000, which amounts to about 4% of the cities space, with approximately 20% of Rio's population residing in them. Taking these problems into consideration, my goal is to make efforts towards solving the water and energy problem in Rio, and improving the quality of life of the people in this region.

The problems I observed during our visit in-situ were the following: first of all, through talking with residents, the biggest need they identified was equal access and distribution of sanitary water. The hilly terrain of these neighborhoods present a challenge for water distribution especially in the upper areas of the favelas, such as Rocinha. Existing infrastructure for water delivery does not extend to these areas. Water safety is another serious, and related, issue. In Dona Marta, there is no drinking water inside the houses. In order to obtain water, residents have to go to the different public fountains located throughout the favela and bring containers of water back to

their homes for consumption. An alternative to collecting water from public fountains is water tanks residents have installed on their roofs which collect rainwater. Though for some fortunate residents the water stored in the tanks is sanitary, supplied by a company called the CEDAE, in most cases, the water in rooftop tanks is recollected rain. Unfiltered, this water presents a public health concern. Sadly, it is a daily reality that people living in the favelas are drinking contaminated water. As a consequence, many people are suffering from conditions like diarrhea, gastroenteritis, vomiting, stomachaches, and in the worst cases, cholera, hepatitis A and E.coli infections. Based on these observations, the following priorities were identified: providing clean drinking water for the whole community and a filtration system needs to be in place for all residents.

We will propose solutions mindful that much of the family and community life in the favelas takes place on rooftops. We need to offer solutions that preserve the customs of life on the roof, preserve the possibility of building new floors for the next generations of their families, and also preserve the life they have on the roofs like cultivating plants, having barbecues and parties, drying the clothes, or enjoying the views. The people need to be educated

“People can create a self-organized market in which the users could offer and distribute their products online”

regarding the quality of water they drink and use. Improving their knowledge about their carbon footprint, water safety and water saving also needs to be a priority. After I identified these challenges, I began thinking about a project where the main idea is using the roofs to start a dynamic market in the favelas with a bottom-up infrastructure. The idea I propose is based on a Rooftop Gardening System; this system consists of a reconfigurable garden in which one of the pieces (planters) can be assembled and added to another stretching out in horizontal direction. The lines of planters may have a main tank of water recollection, distribution, and filtration in order to water the plants with clean non-polluted water. This would also help to provide suitable growing conditions for vegetables that the individual cultivators, may use for their own personal use or trade with their surrounding neighbors. In this dynamic market people can create a self-organized market in which the users could offer and distribute their products online. They can use this market by visiting a website or by using a smart phone application. This would allow them to look for the nearest provider of the products that they require.

For example, User A is cooking, and for their salad they need carrots, but at that moment, User A doesn't have any available in their home. However they do have an assortment of other vegetables on their roof. On their roof, they have beautiful tomatoes, cucumbers, lettuce, strawberries and parsley, but not carrots! Then, User A goes to the website/app, logs in, and looks on a map. The house close to them has carrots; they check to see if at this moment carrots are available; maybe there is a home that has carrots, but there is no one at home. When User A locates a User B who is available at home, User A can ask User B in real time whether User B needs something that User A has on their roof, or if User B prefers to offer his produce in exchange for money, or even in credits/points. If User B chooses, next time they can take anything they want in equal amount

from the roof top garden of User A. In addition, these smart planters are hydroponic; plants are cultivated using a mineral nutrient solution and do not require soil. This approach removes some of the challenges of soil-based cultivation and ensures a healthy yield of crops is produced. Furthermore, the water could potentially be re-utilized and used for several planters; providing a water saving mechanism that is capable of maintaining suitable growing conditions for multiple planters. An extension of this approach would be for the planter to sense the quality of water, the quality of air, the energy saved in the houses, the CO₂ to O₂ conversion of the plants. All the different levels could be shown

on the same planter as well as the information of the other users. Users can access information online when the users login; in addition, there can be a general community map of the different parts of the favelas where users can see the different levels and the available products in real time. The digital market online interface creates a colorful grid mapping out the tops of the roofs in the favelas, with different configurations, providing organic food and clean water for the community. The map and interface visually portrays multiple sources of information, whilst also reflecting the strong sense of community present within these favelas.

The System of Food Connections is created with a Hydroponic System, a water container for watering the plants, and the other containers are for different plants, all of the pieces are linked together creating a complete system



PERSONAL INTERACTIONS

The personal interaction in this project has three different expressions. First of all, there would be a Server System, with the entire database about the information of all the users such as location, products they are growing, cell number, etc. In the first, people can go directly to the planters to look for the information they need using the tactile display they have. In the second one, people who have internet and/or smart phones could be in contact directly using the chat service in one of these smart devices. In the third, for the people who don't have smart devices, as the case for the majority of the favelas, they could use their cell phones. Operating in the market using cell phones is done through the following steps:

1. UserA wants to find some product they send a Text to the SERVER System Number with the product they want

To:FoodConnections(4994)
 Mesg:CARROTS
 From:UserA

2. Then the SERVER System using UserA's location, filtering the other User(s) close to UserA with Carrots and sends a Text to all of them.

To:User(s)
 Mesg:CARROTS required, please reply if available
 From:FoodConnections(4994)

3. UserB answers to SERVER system

To:FoodConnections(4994)
 Mesg:CARROTS available
 From:UserB

4. The SERVER System answers to UserA with the information of UserB

To:UserA
 Mesg:CARROTS available from UserB (617-991-0324)
 From:FoodConnections(4994)

5. UserA sends a SMS/Call to UserB and makes an appointment to share the products.

6. Food connections grow.



Food Connections is a simple system with the goal of creating a dynamic market, using high and low technologies, where users can share different food products as they grow them on their roofs. This market is based on a bottom-up infrastructure.

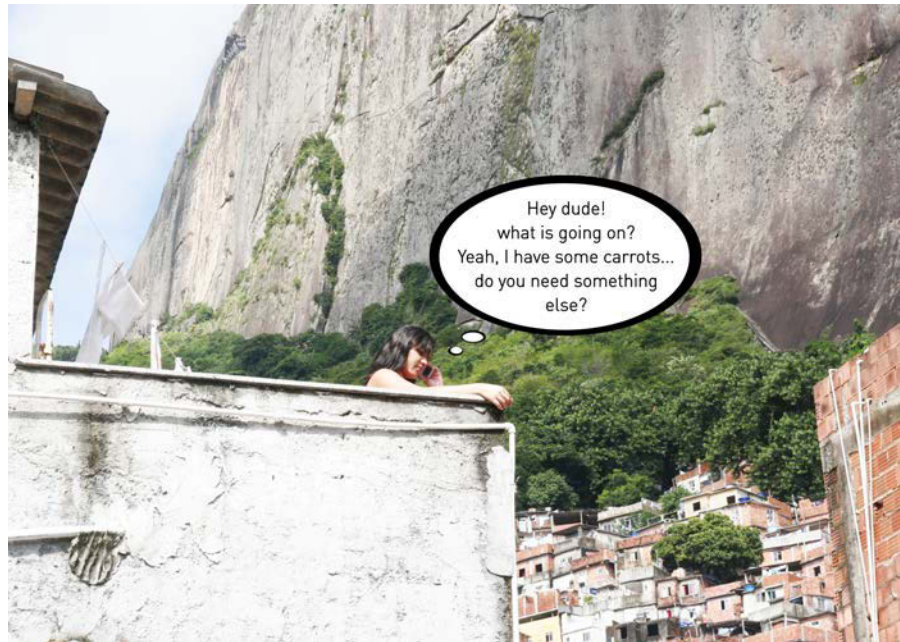

1- User A needs something. 2- Using the device they prefer (internet/ smart phone/ cellphone), people can connect to find the nearest person with the product they want. 3- User B goes to gather the vegetables that User A needs. 4- User A and User B meet to exchange the products.

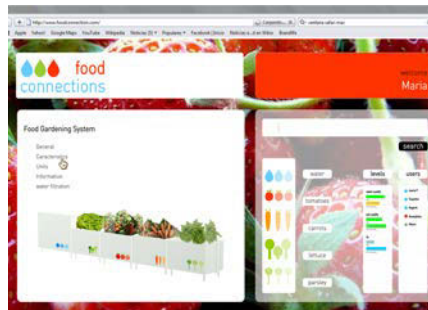

URBAN INTERACTIONS

The Dynamic Market System provides multiple layers of information in real time. For example, mapping the areas where different products are grown. Another layer of information could be related to water consumption and quality. Further serving to inform the populace about the benefits of the hydroponic system. In the same way, the Dynamic Market System could also provide information about CO₂ levels. The Server could also provide information in real time about the activity in this Dynamic Market

System. People could see online the activity in different parts of the favelas.

The information displayed in real time regarding the activity in different zones is very empowering for the users. This may increase the creation of sustainable urban gardening, using their own products and developing a sense of community, utilizing some of the technology available in the global market place to make an efficient and informed local dynamic.

Autochthonous Vegetable
TYPE A

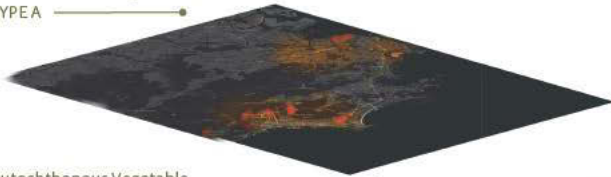

Autochthonous Vegetable
TYPE B

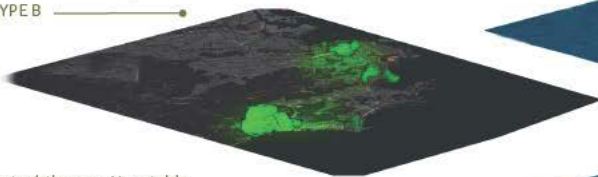

Autochthonous Vegetable
TYPE C

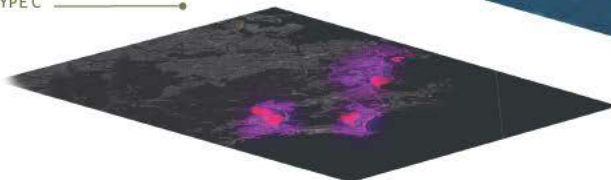

By mapping the levels of water quality and the water consumption, people could be aware of their actual water usage. With this map, users could observe and understand the water information in different parts of the favelas.

Air Quality Levels

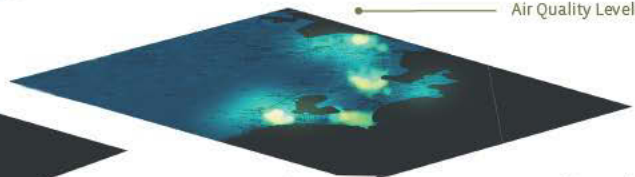

Water Quality Levels

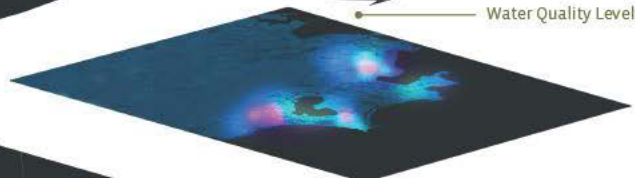



LOGO RIO 2016

Made with vegetables



The possibilities that these pixel gardens offer include the creation of images on the roofs of the houses and give the opportunity to customize these images depending on the event, such as the Olympic Logo Rio 2016.



TECHNOLOGY DESCRIPTION

The technology required for Food Connections has to be capable of portraying this Dynamic Market System. It will require a server which stores all the metadata on producers and cultivators such as their location, crops grown, contact details etc. This server will have a virtual mobile service using SMS software to send text messages to the users when they need information in a two-way SMS service. From short code setup, to account management monitoring, this SMS software will be the mobile partner for the user. And by using SMS and Premium SMS technology, mobile content, news, alerts, and chat services are all available to the users through the SMS software mobile transaction network.

With respect to the necessary technology for the planters, we will need two different components. First, the “hardware” used by the system has to be a smart device which will be built with an LCD display with a touch screen which has PTC (Projected Capacitive Touch); the users would be able to obtain information by merely touching the planter. Second, the planter has to have a Global Positioning System based on a radio navigation system. This would provide reliable locational information in real time to its users. The planter will also need sensors to assess water quality, air quality and food quality; with regard to the hydroponic system, it is an efficient method for cultivating plants using a nutrient rich solution, in water, without the need for soil. Plants are protected from excessive evaporation by using hydro-gels. These polymers are applied over the plants root ball

and effectively retain moisture for the plant preventing drought stress. If the sun is too strong, additional measures such as nutrient reservoir cooling may be used in order to control temperatures around the root zone. The planter would be a “smart garden” utilizing patented SmartValve technology to automatically feed and water the plant, without the need for pumps, timers or nutrient solution management. A hydroponic system, in conjunction with an inert, sterile blend of ultrapeat coconut coir and aerolite super coarse horticultural perlite would provide the growing media.

Benefits of a hydroponic system include reduced water and nutrition cost. Furthermore, pollution is controlled by the system and the absence of soil serves to reduce the bacterial contamination of plants.

Dynamic System Server can be use by smart devices or cell phones using Two Way SMS service

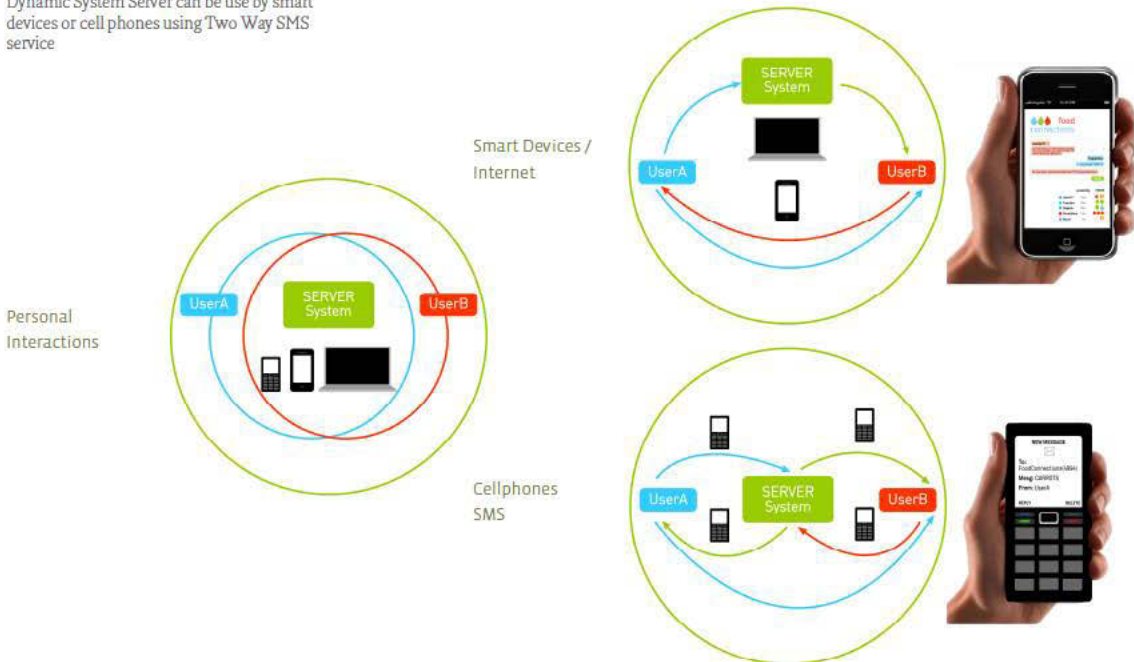

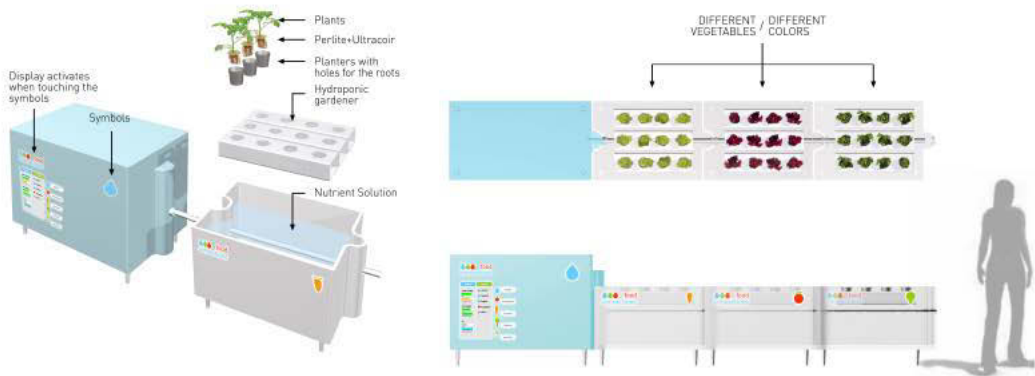

Water tank: filtering water nutrition solution

Plant pots coupled: sharing water depending their necessities



Plant pots hydroponics: growing plants with mineral nutrients solutions in water

No soil needed
Re-use water > lower cost
Control Nutrition Levels > lower nutrition costs
No Nutrition Pollution > controlled by the system



Planters with Hydroponic System and Touch Screen PTC

BÁRBARA RIBES GINER

Born in Alcoy, Spain, she studied Industrial Design at the Polytechnic University of Valencia (UPV). She finished her studies at the Polytechnic of Milan in 2002 and subsequently performed the Master Degree in Design and Management of New Products at UPV. She worked in Paris and Barcelona in studios like NAÇO in Paris, and Estudio Mariscal, and BM Lighting Design in Barcelona. Throughout her career she participated in many exhibitions and contests such as Hall Nude on the International Furniture Fair of Valencia (02/03/04/05), Domus Mediterranean (FIM 2003-04), Showroom Modoloco Design Workshop+ SpanishDesign(Milan 03), ConceptRoom at the Milan Triennale (2004), where she was a finalist with Diana Santana; in the Biennale de Saint Etienne (2004), Design Lab in Paris (2005). Also in 2007 she received a special mention with Alba Sans on the 6th Formica Creativa Contest and the 3rd prize of Product Design in the Twentieth Young Creators Contest of Madrid in 2008. During the year 2008 she obtained a Graduate Degree in Qualitative Research Trends at the Ramon Llull University in Barcelona. In 2010 she was invited by Senseable City Lab to join the workshop Senseable Cities at MIT.



R2

WaterReader

by Elijah Hutchinson



Refresh



Resist

PROJECT DESCRIPTION

The water distribution network in Rio de Janeiro is complex and often informal, resulting in impaired quality and a high prevalence of waterborne diseases. According to The World Bank in 2008 over 19 million Brazilians lacked a safe water supply. WaterReader will allow you to sense water conditions in real-time, providing tap users with the information they need to make informed water consumption decisions. Furthermore, water conditions will be networked; creating an effective tool for long-term sustainable planning.

Having this information transmitted to a network of other WaterReader smart faucets will allow users to compare their water quality with their neighbors and the broader community. Coupling these water quality sensors with basic filters will create a new stream of data that will increase awareness, raise standards of drinking water quality, and positively impact public health. Residents want the comfort of knowing their water is safe, and exposing the dynamics of Rio de Janeiro's water system will make water quality awareness engaging for the wider community.



Rio de Janeiro is a city that in many ways is defined by water. While some of its most prized cultural assets are its beaches, access to clean drinking water has been a continuing challenge for the metropolis' residents. During the World Cup in 2014 and the Olympic games in 2016, the challenge of providing safe water will be ever more apparent. An unprecedented number of visitors and rapid urbanization place significant demands on the municipal water system, straining traditional delivery methods and potentially compromising public health.

Traditional water filters have made water more potable, but more can be done to monitor wide fluctuations in its quality and also provide assurances that the drinking water is safe.

About 80% of Rio de Janeiro's drinking water comes from the Guandu river water treatment facility, but the distribution network is plagued with leaks and unauthorized tapping which compromises water quality, especially in more informal communities. The addition of a water filter on a faucet tap has certainly helped, but filters are often not replaced enough and can become a breeding ground for pathogens and other captured organic matter. In this context, WaterReader will be a powerful new tool that gives information on a personal and real-time scale. This more transparent system of water delivery besides increasing public health awareness, showcases the progress of Rio de Janeiro to connect with communities that are both challenging to access and manage.



PERSONAL INTERACTIONS

WATERREADER

Imagine you lived in an informal community in Rio, you go to the water faucet, turn on the tap, and hope that the water coming out is safe to drink. Monitoring of quality does happen, but tests are done remotely at the water source and are not frequent enough to capture daily fluctuations. Being prepared for a sudden change in water quality is critical to protecting one's health and engaging in preventative action. Information about your water quality may be in an online webpage from the water management company, but chances are you are not checking your personal computer for water service advisories before you get a drink of water, and the scale of the information is inappropriate to represent your household drinking water conditions. Often, it is only after experiencing digestive discomfort one discovers that poor water quality was imbibed. These conditions are all too frequent. So what is the alternative?

Imagine you approach your kitchen sink, turn on the faucet, and the water lights up red, notifying you that your water quality has been compromised. Usually your water comes out a freshing blue, and you know that you do not have to change your built in water filter, because the water coming out of the faucet would have been blinking to warn you of scheduled maintenance. You are uncomfortable drinking red water, and hesitate. Aware that there is a problem, you pull out your phone and login to a webpage that tracks the five other WaterReader faucets in your immediate neighborhood. You notice that your neighbors are having contaminant troubles as well. Immediately, the water management company has remotely sensed the breach in quality and investigates the causes while distributing wider service advisories to your community.

The next morning you awake to find that when you turn on your water, the faucet display is no longer giving you a water quality warning message, but instead advises you to change your water filter by blinking. When your water is clean, the water turns blue again, letting you know that it is safe to drink.



The personal interaction extends beyond your reaction to your faucet water changing color. You see yourself as a part of a network, and have a new platform for communication

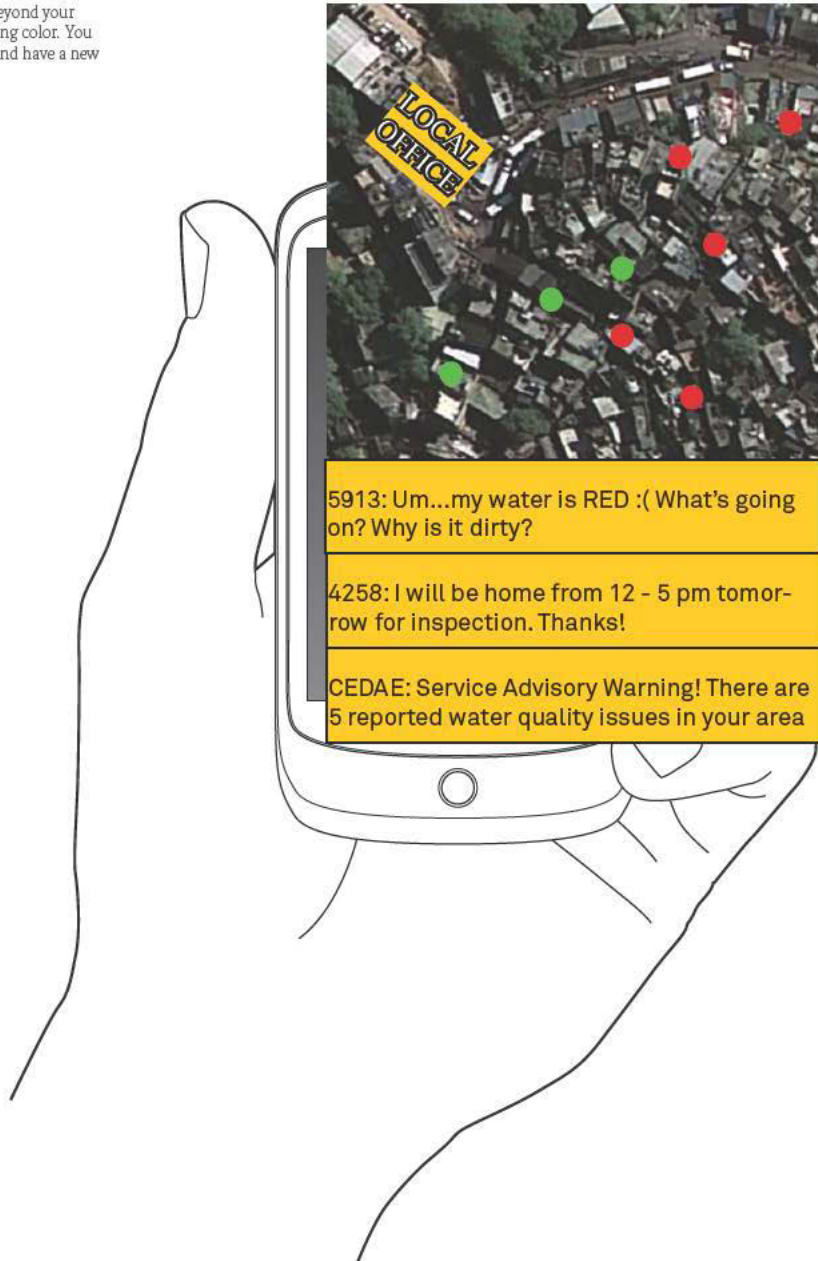

URBAN INTERACTIONS

Using WaterReader, we have redefined the traditional water infrastructure and created a participatory mechanism for advancing water quality and reducing waterborne illness. WaterReader faucets, especially in strategic at-risk locations, can give feedback to the water distribution system and create a dynamic quality monitoring environment for the benefit of customers and utility companies alike. When this data is aggregated on the neighborhood scale, a rich visualization is created that can be viewed online or by using a smart phone. This allows individuals to see how their water infrastructure is interconnected and impacted by issues of development, weather events, and other supply fluctuations.

Having information of this quality and at this scale is unprecedented for monitoring the urban water infrastructure. Only recently has remote quality sensing of water bodies been attempted in select countries. The results have been

reduced water quality monitoring costs and reduced response time to quality fluctuations. In Brazil, there are several substantial challenges in servicing informal and low-income communities due to a weak institutional and regulatory framework. Water quality is an issue that impacts Brazilians across class and racial lines. New spatial links created between lower-income communities, dense high-rises downtown, and the environment, facilitate the formalization of complex spatial and social relationships. The use of this technology also provides a platform for communication between water providers and customers who may lack the incentives to engage with a water utility provider about quality or access issues. Certainly this data will be helpful in engaging in long-term planning for water infrastructure and capacity. Implementing this networked model of service delivery will put Rio de Janeiro at the forefront of water resource management.



When this data is aggregated on the neighborhood scale, a rich visualization is created that can be viewed online or by using smart phone.

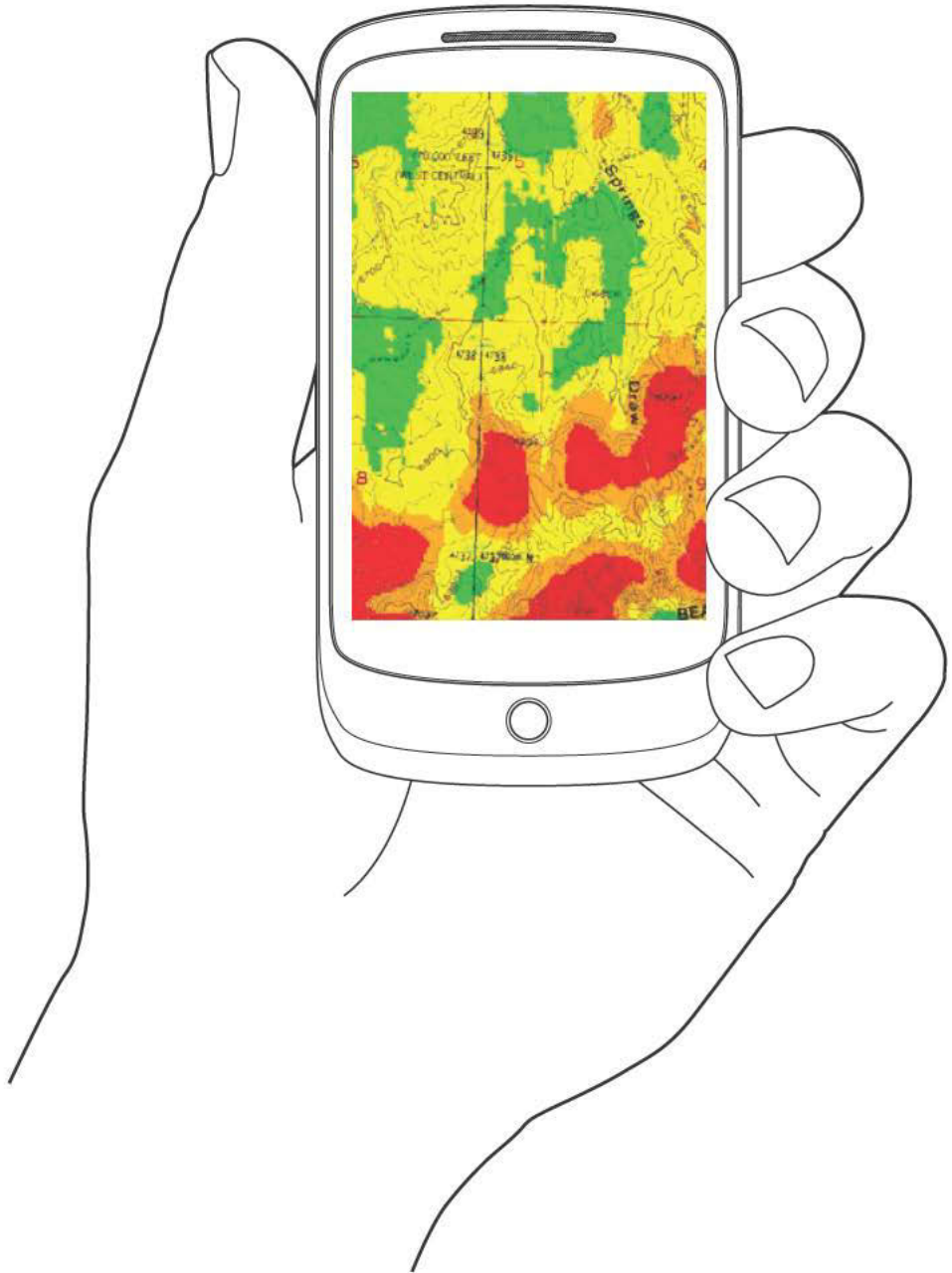

TECHNOLOGY DESCRIPTION

Pure and contaminated water can be identified through the detection of color-shifts in the infrared spectrum. These shifts can be monitored in real time and presented to the water user, alerting them to abnormal conditions. The actual sensors can be made of fibers that are insoluble, non-toxic, and constructed from biocompatible materials—essentially they are harmless even if consumed.

This technology avoids requiring an incubation period for a cultured sample or subsequent protracted lab tests. Also, for a consumer, detailed information on specific contaminants present may be irrelevant. For the purposes of individual awareness, it is only necessary that they know that something is wrong, allowing the water company to further investigate the matter.

Detecting variations also does not limit the items one can test for by the number of sensors in the device. For example, an individual sensor for pH, salinity, or a particular pesticide is no longer required. Rather, by monitoring a calibrated range of acceptable variation, one can monitor the overall condition of the water. These sensors will be integrated into a user interface that alerts the user to shifts in quality by changing the color of the water using LED lights attached directly to the spout of the faucet.

Using wireless network technology, this information can be fed to servers maintained by the water company for distribution over the internet or by telecommunication providers. Data from the individual WaterReader points can be displayed on a map or generalized to certain areas in a neighborhood for visualization purposes. They could also collect the filter and analyze what substances have or have not constituted a breach in quality. In turn this system provides a rich data source and the potential for further refinement of the infrastructure.



LED lights convey the real time results of the spectrophotometer. Red means don't drink, blue means the water is clean, and blinking lights mean that it is time to change your filter

Above is an example of an infrared spectrophotometer that can detect 'colors' in the infrared spectrum to differentiate between pure and contaminated water. This spectrum is not visible to the human eye, but devices like these, using special silver-halide fibers, can detect pollutants in real time.



ELIJAH HUTCHINSON

Elijah Hutchinson is currently a Masters in City Planning student at Massachusetts Institute of Technology, specializing in Housing, Community, and Economic Development. His interests include bringing sustainability to the marketplace and empowering communities through economic organizing. Elijah Hutchinson is a native of Brooklyn, New York and has worked in affordable housing development and policy prior to graduate school. He received his undergraduate degree in Biological Anthropology from Harvard College where his academic interests focused on evolutionary psychology and adaptive human behaviors. The WaterReader project is a culmination of various interests, including advancing infrastructure and quality of life in challenging political and social contexts. One guiding principle for his work is that technology has the potential to bridge the gap between environmental sustainability and communities that have been historically disadvantaged.



R3

The Lula Project

by Eric Baczuk

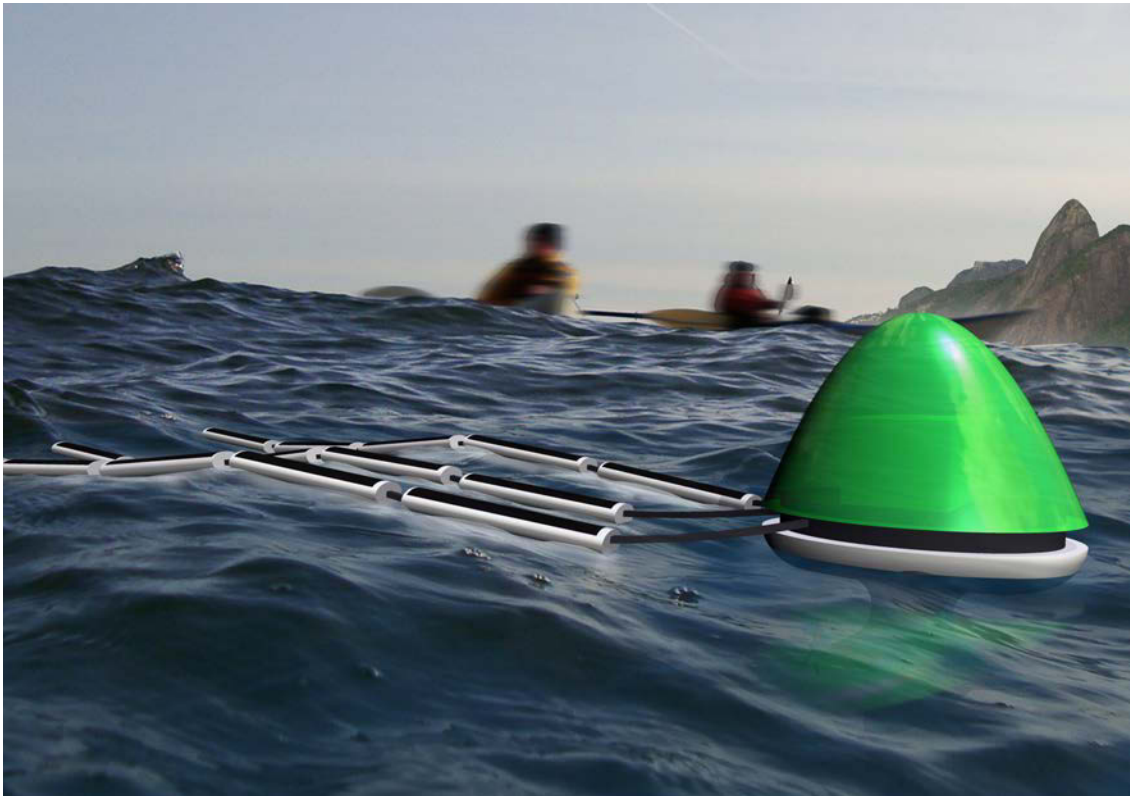

PROJECT DESCRIPTION

CHALLENGE

Over 80kms of beachland line the coasts of Rio de Janeiro state, providing a critical venue for public recreation, social interaction and cultural identity. These sandy expanses between land and sea play a vital role in the joie de vivre of Rio de Janeiro. Day and night you can find friends, families and lovers walking along the boardwalks, jogging, rollerblading, playing volleyball, soccer, swimming, reading, surfing, playing futevolei (volleyball using only feet), and listening to Bossa Nova. Rio is also Brazil's primary tourist destination. It receives the most visitors per year of any city in South America with 2.82 million international tourists annually. Visitors from around the world flock to Rio's beaches, injecting millions of tourist dollars into the local economy every year. However, Rio's beautiful beaches and the unique culture they harbour are gravely threatened by biological contamination and industrial pollution. While the city has a long history of thriving tourism, the industry entered a decline in the last quarter of the 20th century and has yet to recover. One of the primary reasons cited for the downturn was beach pollution.

As the third largest port in Brazil, over 7 million tons of cargo is shipped through the mouth of Guanabara Bay every year. While such intensive marine activity is important for Brazil's Gross National Product, these diesel-powered vessels - over 1700 ships, liners and barges annually - exert great pressures on the aquatic ecology of the area. Additionally, since the 1960's oil exploration, extraction and shipping in the state of Rio de Janeiro has increased to become a mainstay of the Brazilian economy. Inevitably, as such industry continues its expansion so too does the likelihood of a major environmental catastrophe.

Indirectly, another threat to the persistence of Rio's beaches and

beach culture comes from the sky. For over a century, the state of Rio de Janeiro has been notoriously plagued with landslides and extensive flooding from major rainfall events. These storms often overwhelm the municipal sewer systems and inundate the streets, alleys and homes of the city's low-lying areas. As the storms pass, flood waters recede into the ocean, taking along with them a mélange of urban residues, toxic substances and sediments. Such chemical shocks can greatly impact the water composition of Rio's oceans and can have dire implications for the regions aquatic flora and fauna. Finally, and perhaps most importantly, the single greatest threat to the beaches and culture of Rio comes from untreated municipal sewage and waste. As migrants from across the county flock to Rio, great stress is placed on the water infrastructure of Rio de Janeiro state. It is estimated that of the 5 million people that will re-locate to Rio in the next 10 years, 3 million will live in informal housing. This rapid urban influx combined with the city's current dearth of sewage and sanitary infrastructure suggests that most of this burden will likely be borne by the oceans surrounding Rio de Janeiro. Much of the untreated sewage from favelas such as Mangeirinha, Ramos and Jacarezinho flow directly into Guanabara Bay, while Rocinha, Vidigal, Vila Canoa, and the many small favelas of Lago Tijuca all release their untreated sewage effluent into near-shore outlets on the Southern shore. These inputs lead to nutrient

Beach pollution was cited as one of the primary reasons holiday makers chose not to visit Rio de Janeiro...

loading and algal blooms, which reduce the dissolved oxygen content of the seawater and threaten marine life in these unique habitats. However, the more formalized, state-run wastewater infrastructure is arguably much the same. Sewage collected by the municipal sanitation systems drains almost directly into the ocean through kilometer long diffusers on the ocean floor - much of it having received only primary treatment. So the main difference is that the formal sewage systems pipe the wastewater out many kilometers to sea, where it can be better diluted. The informal sector, however - lacking such infrastructure - empty their sewage directly off the shore, adjacent to the cities beaches. Both methods pose significant threats to the long-term viability of Rio's municipal beaches.

OBJECTIVE

While everyone in Rio will give you an opinion on contamination levels of the city's many beaches, hardly anyone knows for certain which beaches are most affected and to what extent. The objective of this project is to quantify such information and bring it into the public realm and social consciousness. By establishing a public-private initiative that directly addresses the issue of ocean water quality, citizens can become actively involved in the decisions and actions that affect the quality and future of their municipal beach parks. Offering a platform of reliable, statistically based and publicly accessible information will spur environmental awareness and advocacy for Rio's beaches and oceans, while empowering the public to make more informed decisions about where and when they go swimming. Such a record will also allow the city and it's industries to track their individual and collective progress over time, thus encouraging further improvements in the future.

STRATEGY

Today's water monitoring sensors are wafer-thin, highly accurate, mass-produced and economical. Water temperature, pH, dissolved



Red colored LULAs inform beach-goers that the water quality today is poor, and that swimming here is ill-advised.

oxygen content, salinity, electrical conductivity, coliform, and BTEX levels in seawater can all be measured instantly and inexpensively. By combining numerous individual sensors into a single, multi-performative device, we can gain a clear, broad-spectrum understanding of water quality conditions around Rio's oceans and beaches. The LULA project proposes a network of remotely controlled mobile sensors/transmitters that will patrol Rio's seafloor. These wave- and solar-powered, SMS guided units could

become the icon for the future of Rio's beach culture and the rebirth of the Zona Sul as a global tourist destination. Hundreds of LULA's could be deployed into the bays and beaches of Rio de Janeiro state, transmitting real-time information about concentration and nature of pollution on Rio's beaches. This information could then be collected, updated and broadcast on interactive websites, newspapers, media installations, or accessed via a wireless handset. Access to such relevant and reliable information in real-time would empower Rio's citizens to make more informed decisions about what beaches they swim at and fish from, while the transparency of the program would force accountability from local

industries. As urban populations continue to grow, environmental sensing technologies will likely play an increasing role in ensuring the maintenance of public health infrastructure, and ultimately help Cariocas preserve a critical component of their cultural identity. Through funded, community based initiatives, Cariocas will regain their sense of ownership over these highly valued places. By combining federal resources with industry experience from GE, the people of Rio will collectively hold the power to direct the fate of their local oceans. Together with GE, Projecto LULA will set a global new precedent for the age of ecological urbanism and will serve as a model for coastal cities around the world.

PERSONAL INTERACTIONS

The keystone of the information system is the remote mobile sensing units - called LULAs the Portuguese word for 'squid', taken from their pointed 'head' and bobbing 'tentacles'. These autonomous floating devices rely on color-coded visual cues to communicate water quality information to those in visible range. Red means danger, yellow means fair and green means excellent swimming and fishing conditions. From the beach, pier or boat Cariocas will be able to look at what has never been seen before; real-time, continuous sensing and monitoring of seawater quality in the ocean around them. For the first time in history, citizens and visitors to Rio will be able to decide whether or not to dive in or cast their line based upon precise, up-to-date knowledge of local seawater conditions.

Each LULA unit travels along on a centrally controlled 'route' continually testing and reporting ocean conditions back to a processing center onshore. The center decides the specific routes and location of the LULA units based on pollutant concentration, time of day, location

and weather, to ensure that a broad and accurate picture of seawater quality is maintained across all of the city's beaches and ocean. However, LULA gives particular attention to the areas most frequented by people, especially when large groups are in a particular zone. Citizens can also communicate with LULAs via SMS messages. For instance, if you're about to go swimming at a remote beach, but don't see any LULAs around, you can simply send an SMS message to the central control center and one will be sent over to you. Or, if you're wondering exactly what kind of contaminants your local LULA is detecting, you can request more detailed information from them, which will be sent directly to your phone. Information collected from LULAs would also be compiled and broadcast on an interactive web space that could be followed like Twitter, keeping concerned citizens up-to-date with ocean conditions at their favorite beaches or fishing holes. This data could also be transmitted across various urban media displays or even via print or television, like the daily weather report.





Communicate with LULA via SMS!

From up-close encounters to city-wide media displays, LULA keeps Cariocas informed about the status of their oceans and beaches.

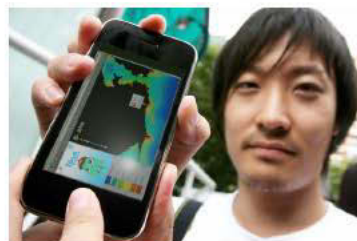
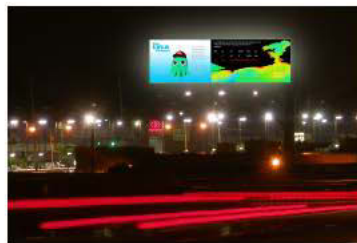

The
LULA
Project



URBAN INTERACTIONS

More than simply reporting real-time seawater conditions, the web presence for the LULA information system serves a more lasting and important role for the communities of Rio de Janeiro. The LULA website is also a forum for seawater quality reporting and activism. By following updates and searching through the on-line historical browser, concerned citizens can quickly identify which regions of their city most often receive the highest quality rating and which areas continually report the poorest results. From this point, connections can start to be drawn between pollution sources and the beaches they affect. For instance, say your favorite local beach has had a 'poor' or 'hazardous' rating for a number of months. You can trace the source of this pollution - using the online LULA map - to a point source origin. The site then allows you to either a) leave a comment on the situation - describing your

displeasure with, or approval of the activities in the area, or b) propose a general solution to the problem - which is both legal and reasonable in scale. Picking up from the example made earlier, say you determined that the continually poor water quality rating at your favorite beach was the direct result of a nearby storm drainage outfall. You could make a proposal on the LULA site for this outfall to be diverted to the municipal sewer, or for a small wetland to be constructed at the outlet. Throughout each month, an online tally is maintained to determine which initiatives the public feels most strongly about. At months end, if your proposal is selected, the government will commit money to the project and a partnership between you, the community, and technical experts at GE will be forced to ensure that the collective water quality issue gets fixed.

The two images below describe the improvement in seawater quality observed in the Rio area between 2011, when the project will be first implemented, and 2016, when Rio will host the Summer Olympic Games. The LULA information system provides citizens with an accurate picture of the sea water quality around them, and offers a hands-on, community led approach to infrastructure redevelopment in Rio de Janeiro.

Because Carioca's are typically very skeptical about the uses of public funds, the Public Private Partnership of the LULA project would allow for a corporate entity (GE) to front the project while the state benefits from the real improvements made to its ocean environment and revived tourist trade.

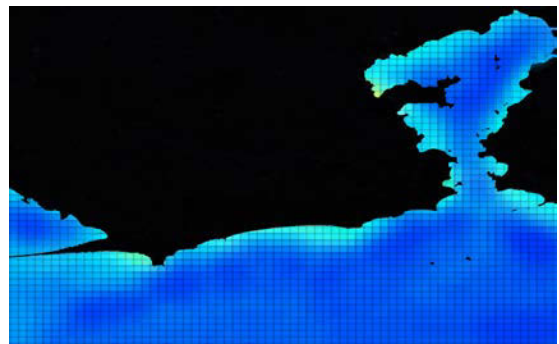
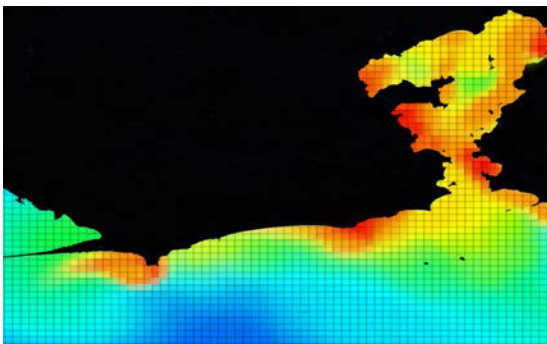

TECHNOLOGY DESCRIPTION

SENSING AND COMMUNICATION

The most recognizable component of the LULA information system is the mobile ocean sensors. These devices are capable of detecting minute concentrations of mercury, lead, zinc, arsenic, BTEX (petrochemical compounds) as well as various nitrates and phosphates through a multi-performance sensor array mounted on the sides of LULA's buoyant 'head'. Inside, this 'head' also contains all of the digital processing and communication equipment (transmission technology similar to cell phone radio waves) used to relay the collected data back to shore. LULA also uses inexpensive, solid state and low energy flash memory for processing and storing its collected information.

LED AND EPD DISPLAYS

In order to visually share the results of their analyses, LULAs rely on a vivid color-coded digital display to communicate the status of water quality in a given area. However, because of the autonomous nature of LULAs, this display must be both powerful and low energy. Throughout the day, the units rely on sunlight to reflect color from their exterior surface. The color reflected from this surface can be dynamically controlled using technology similar to Electronic Paper Displays (such as Amazon's Kindle). At night, LULAs activate a small bank of RGB LED nodes, located beneath the outer shell, to give the unit it's gentle glow. Their very low power consumption means that LULAs can sample and display water quality information 24 hrs a day, 7 days a week.

POWER

LULAs dangling tentacles are actually the powerhouses of these autonomous units. Relying on a combination of wave and solar energy, and buffered by a Lithium Ion battery, LULAs can swim, sample and transmit information about water around the clock. The "tentacles" are actually wave actuators that convert kinetic wave energy into electrical power through a series of hydraulic pumps. This technology was inspired by the Pelamis offshore wave energy converters developed at the University of Southampton, UK, and ensure that as long as the ocean is rippling, electricity is being supplied to LULA. To augment this system, the buoys of the wave actuators were covered with Photovoltaic cells to provide an additional source of energy to the unit.

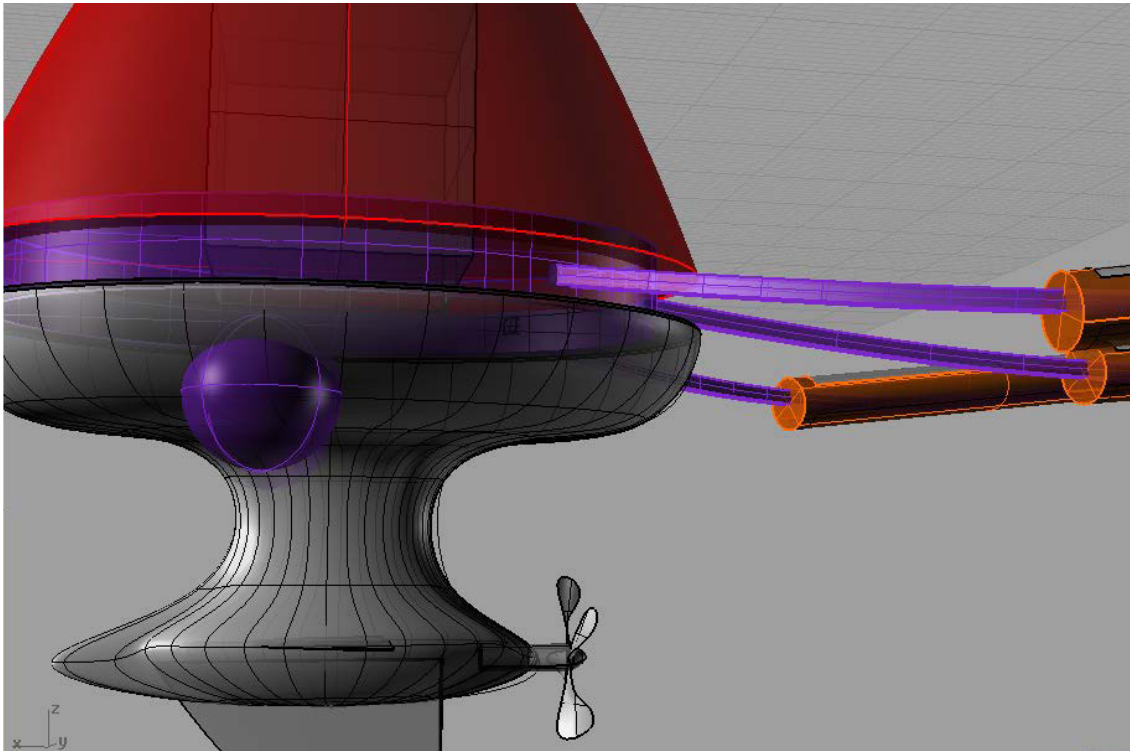

A DAY IN THE LIFE OF LULA

Imagine you were someone that brought together people from all walks of life, across all social barriers, racial divides and class structures. Imagine you were the common thread that tied an entire city together. Imagine you were the hope for the future - where knowledge and environment seamlessly integrate into one dynamic, responsive entity. Imagine you had the power to change the world...

Now you can.





ERIC BACZUK

Eric Baczuk was born in Calgary, Canada, where he attended the University of Calgary on an athletic scholarship (Men's Soccer), and graduated with a B.Sc in Environmental Science (2005). Looking to apply his interest in sustainability to the built environment, Eric enrolled at Dalhousie University, where he received a Bachelor of Environmental Design in 2007 (with distinction) and a Masters Degree in Architecture (2009). While at Dalhousie, Eric conducted exploratory research on renewable energy infrastructure in Eastern Canada. His Masters thesis focused on deriving architectural program and typology for tidal in-stream energy conversion facilities in the Bay of Fundy, Canada. This project was widely recognized nationally, receiving awards from Dalhousie University, the Canada Arts Council and Canadian Architect magazine. Professionally, Eric has worked in the London office of Foster+Partners, contributing to a host of large-scale civic, cultural and commercial projects in the United States, Canada, England and Mauritius. He is currently completing a Master of Design Studies degree at Harvard University.

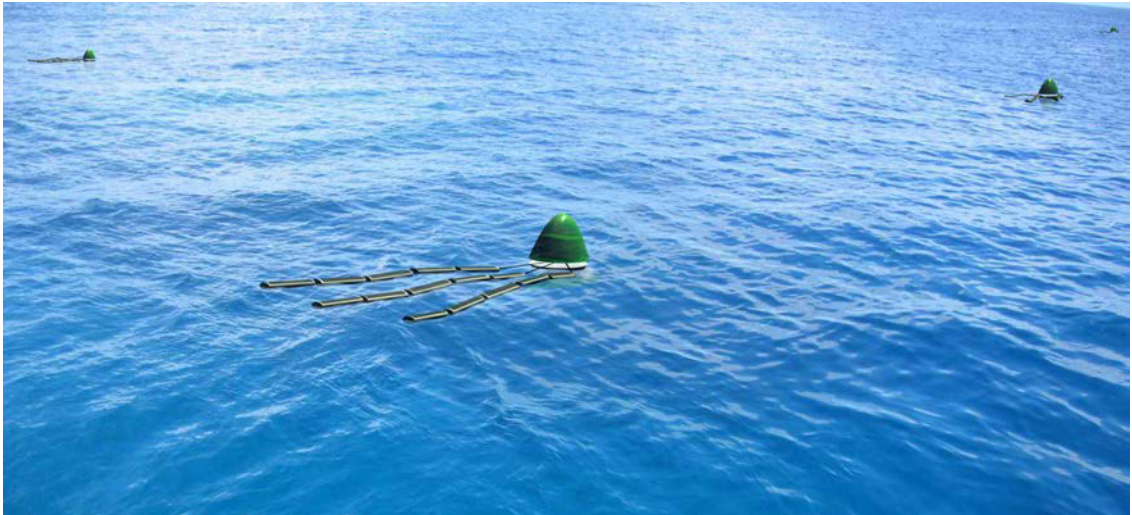

R4

The Sensing Nose

by Okhyun Kim

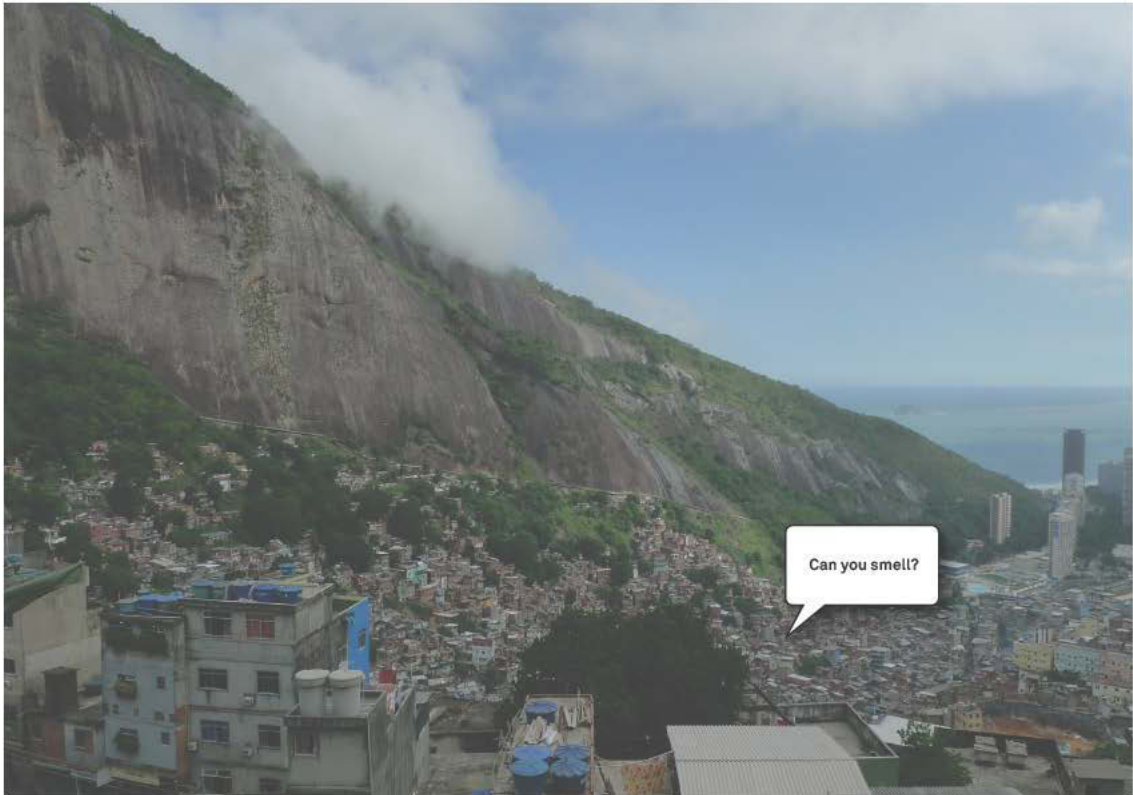

PROJECT DESCRIPTION

SENSING CITY THROUGH SENSING NOSE

The Sensing Nose project is about revealing a new city space that can be perceived. This project assumes a novel perspective on the issue of air quality in Rocinha. It seeks to make the invisible environmental problems of the area more tangible and sensible through the employment of olfactory sensor technology. In this project, I ultimately hope to illustrate the significant role perception plays in behavioral changes among the individuals within a community. Furthermore it will serve to demonstrate how sensible data can bring a new level of awareness of public health and action on environmental problems. In the long run, the sensing nose will help to create a sensitive built environment that enhances the quality of life.

OLFACTORY EXPERIENCE IN ROCINHA

For first time visitors to Rocinha, one of the most unforgettable aspects of their experience is the odor from the wastewater. Following heavy rain, the odor can become overpowering, as the water overflows the sewers.

Air quality presents an issue not only outdoors but also indoors as well. Due to the informal architectural condition of Rocinha and its dense construction (many alleys are narrower than 1m), natural ventilation is impeded, with air flow becoming stagnant. Moreover, the multi-story buildings limit sun light from entering the compact conurbations. The windows are too small or too few in number to allow for sufficient air circulation to provide ventilation. The sunlight rarely reaches the bottom of the deep alleyways or the interior of the building. The interior spaces remain humid and dim, and become stagnant leading to poor indoor air quality. The pervasive airborne odor, now presents a public health concern for the inhabitants of Rocinha.

POLLUTED AIR AND HEALTH HAZARD

It is not so easy to effect immediate action or behavioral changes regarding this conspicuous threat. There is often a lack of impetus to improve air quality and reduce pollution due to its intangible nature. Furthermore, with other challenges facing residents of Rocinha on a daily basis, air pollution is not a priority. With prolonged exposure, residents have become accustomed to the poor air quality, especially as it does not present an immediate threat. From an anthropological and a biological view, olfaction is an important part of human perception. Several studies have examined the relationship between the indoor air quality of this area and the prevalence of respiratory diseases, especially among the children. Tuberculosis has been one of the most serious health problems in the area.

HOW TO BRING A CHANGE

In order to improve air quality, it would prove informative to review with the intention of expansion, the waste water treatment infrastructure. Also the buildings should be designed in a more sensitive way, considering ventilation and lighting. However making these large scale changes in Rocinha proves challenging. Thus, I wanted to start with a small scale change. I will provide a wall mountable ventilation fan with an embedded sensing nose. The sensor will detect the indoor air quality and automatically run the fan when there is a need for ventilation. The sensor will record the change in the air quality and the report will be saved for retrieval later. Although the immediate enhancement in the air quality by providing ventilation is a temporary solution, the sensing nose will serve to raise awareness of air quality. Also, the Sensing Nose project will be valuable

The Sensing Nose will set up a new perspective on the air quality problem of Rocinha by making the invisible problems more sensible through the olfactory sensor technology.

in providing a more comprehensive picture of public health within Rocinha and in establishing direct links between the air quality and human health. Making air quality data more sensible at a personal level can initiate more emotional and physical involvement from the residents. Improving knowledge of

air quality and access to information through the integrated sensing technology will assist to find more appropriate solutions. Concurrently it will bring more active forms of intervention and acute awareness that will lead to a real socio-environmental change in Rocinha.

The multi storey buildings are situated very close to each other. Insufficient supply of sunlight and poor air circulation creates undesirable environmental condition in this alley.



PERSONAL INTERACTIONS

The Sensing Nose ventilation fan will be distributed among households that don't have an adequate ventilation system and households with vulnerable inhabitants such as the elderly or children. Help for installation will be provided. Management and cleaning guideline will be offered.

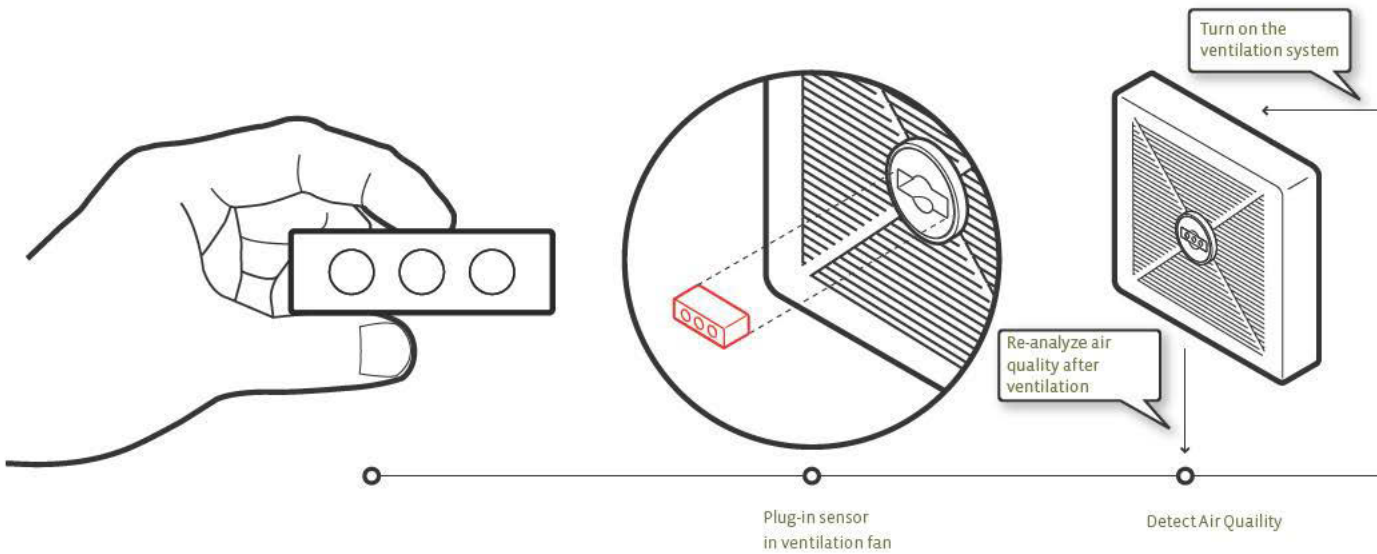
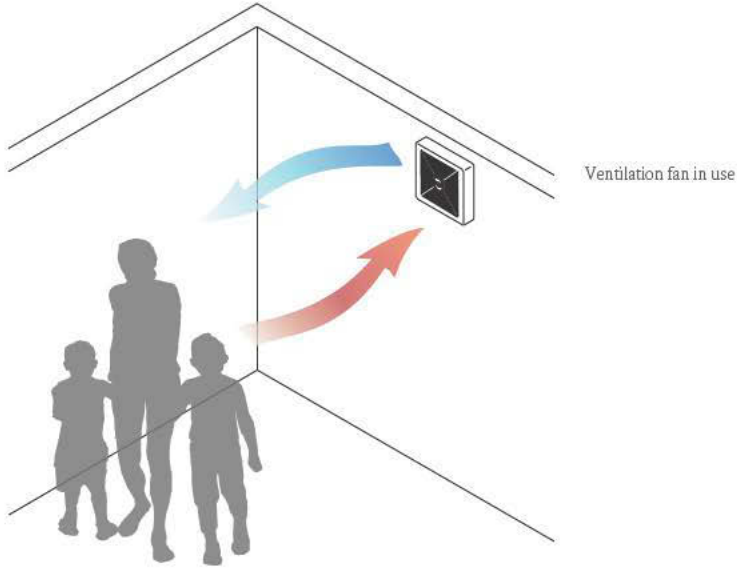

PROCESS OF INTERACTIONS

1. DETECT:

When the e-nose device is plugged into the fan, it automatically starts to detect the quality of the air nearby the user. With the most up-to-date technology, the 4x2 cm sized sensor is able to detect the various harmful VOCs in the air.

What to detect:

Nitrogen, Methane, Ammonia, Hydrogen Sulfide, Carbon Dioxide, Temperature, Location, Time, Humidity

2. ANALYSIS:

The default threshold setting for each evaluation category will be provided for ease of use. However, the detection threshold levels can be adjusted to meet individual needs or specific weather conditions. The analyzed data will be in turn provided to the user. Personal data can be stored online in personal accounts. The data history from previous sessions can be retrieved for more comprehensive analysis of long term trends, with daily,

weekly, monthly, yearly data logs available. This function can be used for further analysis to examine the relationship between prolonged exposure to air pollutants and its impact on personal health.

3. REPORT:

Alerts using the iPhone alarm function will also be provided. Users can personalize the alert, selecting from the options: sound, vibrate, and light mode. Based on the analyzed data, suggestions can be made to request the prompt reaction of the user, for example, to contact healthcare provider.

4. SHARE:

This option is to create a connection and interaction within the urban setting, specifically within the community of Rocinha but also with the rest of the city of Rio. The healthcare provider can access information and data for research purpose.

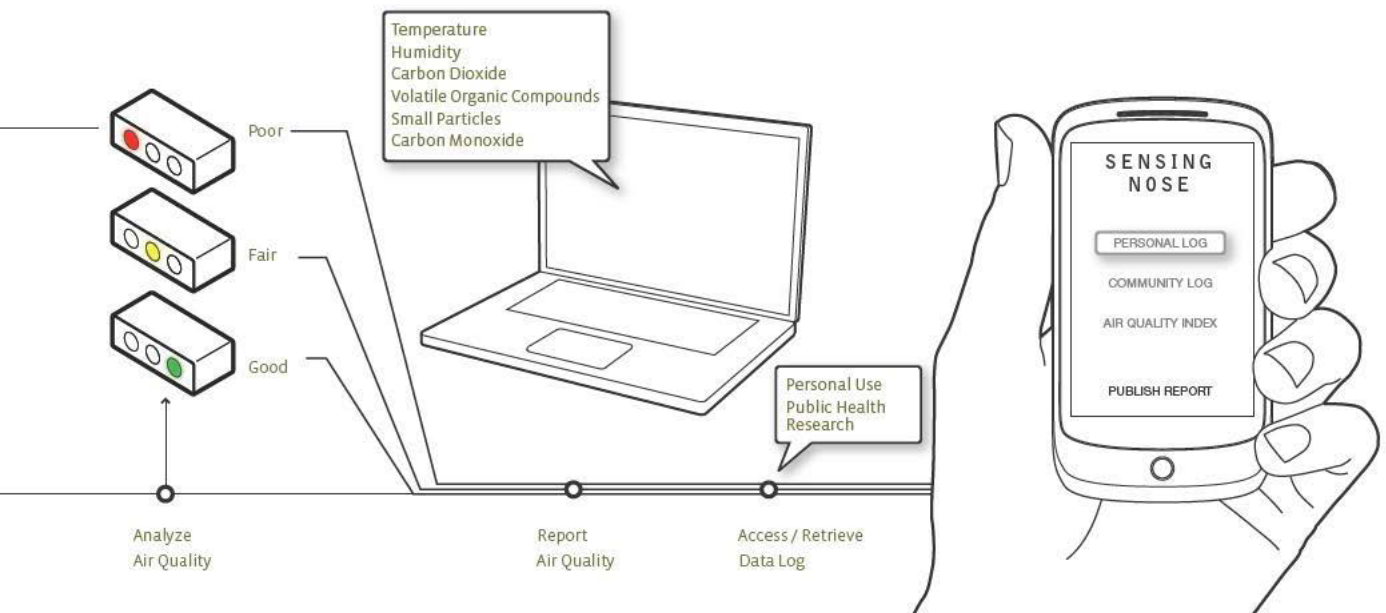

URBAN INTERACTIONS

The data collected from each household can be integrated with data collected at the urban scale. It will provide an insight into the direct and indirect connections between the outdoor air quality and the indoor air qualities of the area. It will be a useful tool to indicate regions that are exposed to high levels of air pollution, further helping to focus limited resources on targeted areas.

Indoor air pollution report during the month of May

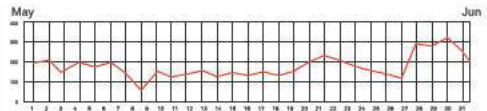

Medical Cartography

Dr. John Snow's Ghostmap: the spatial distribution of the 1854 cholera epidemic in London, which centered on a contaminated water pump.



Main street of Rocinha: motorcycle emissions are a major source of air pollution.

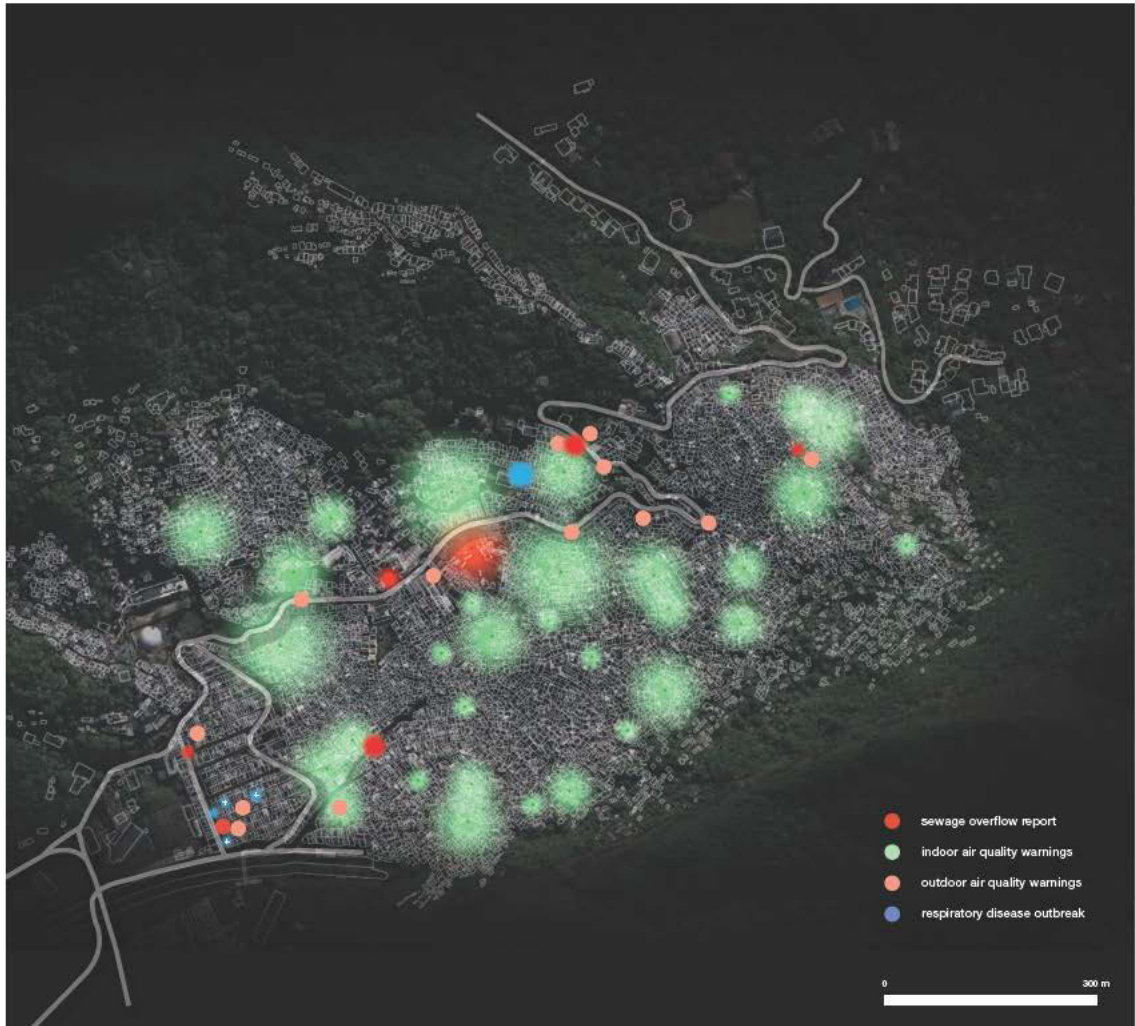

TECHNOLOGY DESCRIPTION

Technological timeline of artificial nose research

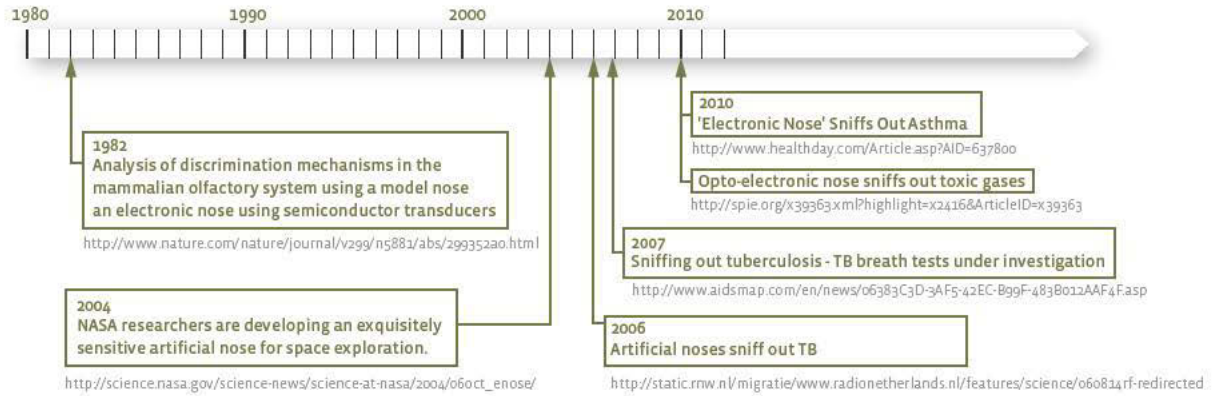

Metal oxide semiconductor (MOS) sensors

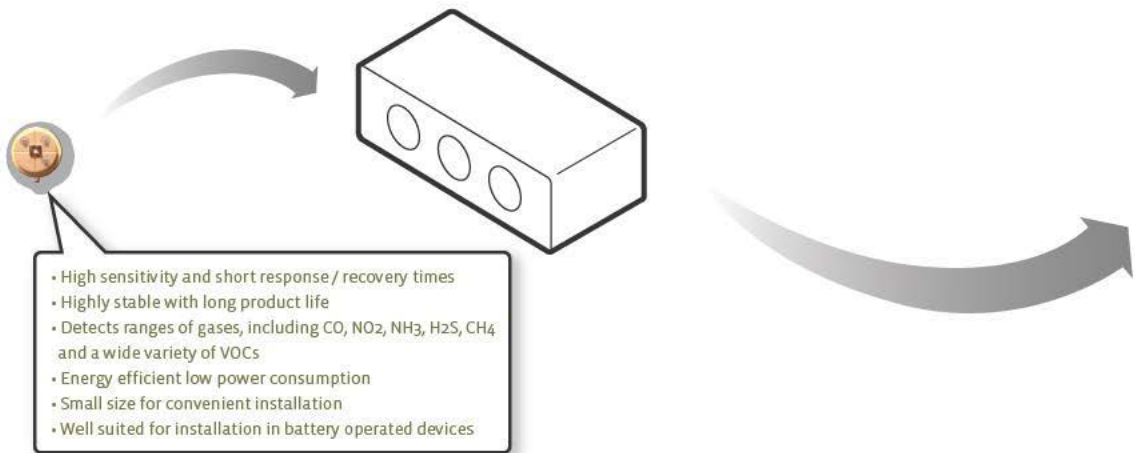

Axometric diagram:
the e-nose sensor embedded ventilation fan

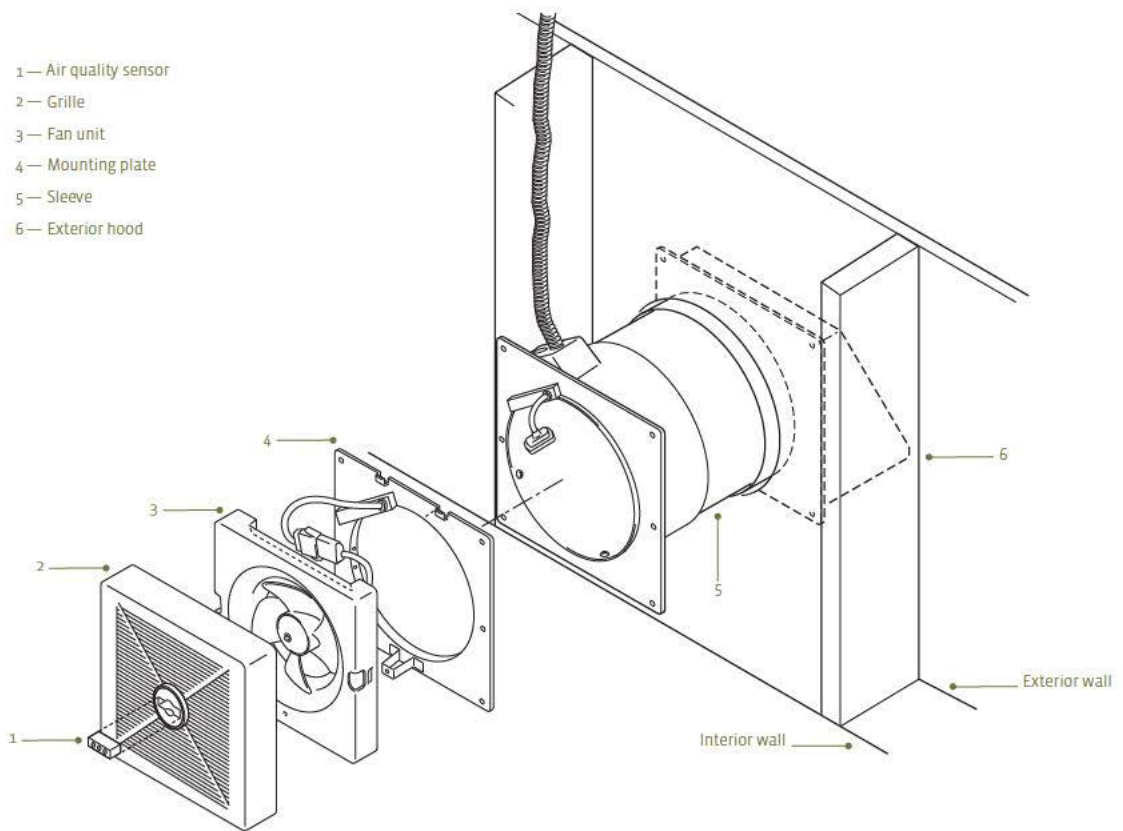

OKHYUN KIM

Okhyun was born in Korea and received a Bachelor of Science in Human Environment and Design degree from Yonsei University, Korea, and a Master of Fine Arts from the School of the Art Institute of Chicago. She is currently a Master in Architecture candidate at the Harvard Graduate School of Design(GSD). She has previously worked with HHF Architects in Basel, Switzerland and with MVRDV in Rotterdam, The Netherlands. Ever since she started the MArch I Program at the GSD, Okhyun has been interested in the role of human perception and its profound role in embracing phenomenological experiences found in architecture and urban spaces. More specifically, she is interested in how architecture can challenge the current visually obsessive culture in our built environment; our experience of space is no longer just a visual experience but it must be greatly enriched by activating other senses including the olfactory, tactile, thermal, and auditory senses. And she wishes to act on this belief to create the built environment that touches us.



R5

Beach Fashionsense Rio 2016

by Otto C L Ng

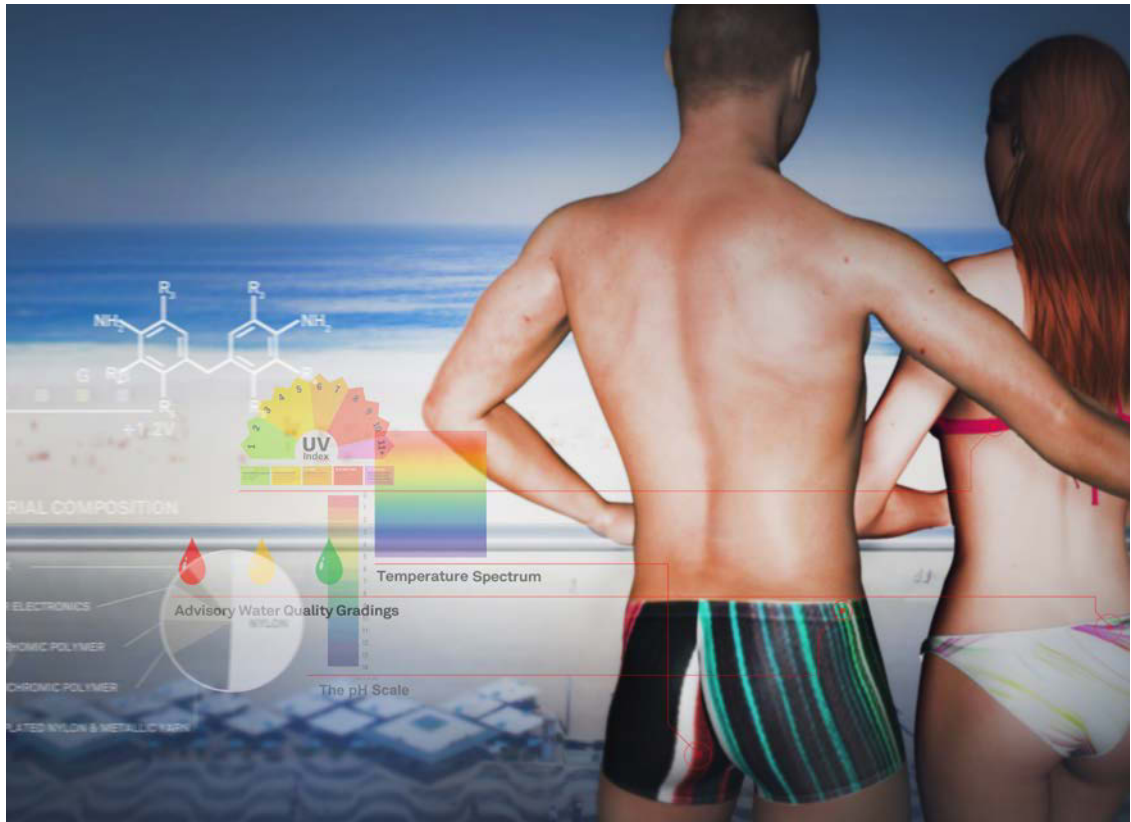

PROJECT DESCRIPTION

Water stress is there! In Rio de Janeiro, access to clean water has been a critical issue affecting economic activity, tourism and people's health. Being the host city of the World Cup and the Olympic Games, Rio faces the largest ever transient demand on its water infrastructure. The influx of visitors could potentially overload the current water supply and sewage treatment system. Sewage is treated and drained to the ocean which is in fact the major source of water that is supplied to Rio for consumption. Beach culture is an important part of life in Rio. Beaches are undoubtedly the major reason why travelers visit the city. Even though popular beaches including Copacabana, Ipanema and Leblon appear fine, without scientific assessment, you may have neglected the risk. In case of flooding at the sewage canal or irregular flow of water from the polluted Guanabara bay in the north, these beaches could be contaminated in a way that you are not aware of.

Other factors also present additional pressure on water quality such as industrial growth at 10% a year and the construction works for urban regeneration. In this context, water quality is an utmost concern, as it presents hidden risks to health including skin rashes, pinkeye, respiratory infections, meningitis, hepatitis and stomach flu. Join AQUA'QUAL: THE MEDIA OF WATER! Become a volunteer in the mission network of AQUA'QUAL and help observe and defend the wellbeing of the water infrastructure and ecology.

Volunteer for Mission AQUA'QUAL with the most fashionable sensing tool - the SENSEable Swimwear, to test beach water. Visiting volunteers can pick up the toolkits upon their arrival in Rio at your accommodation. You carry out water assessment during your daily activities in Rio, therefore the frequency of assessment is always relative to the demand of water. In other words, the sensing network is powered by individuals and quality in Rio, both displayed locally on the body of the beach-goers and globally on the web and social network.

Even though popular beaches including Copacabana, Ipanema and Leblon appear fine, without real-time scientific assessment, you may neglect the hidden risk.



In any poor circumstances, some colors will fade away. Color remaining indicates the sensing result.

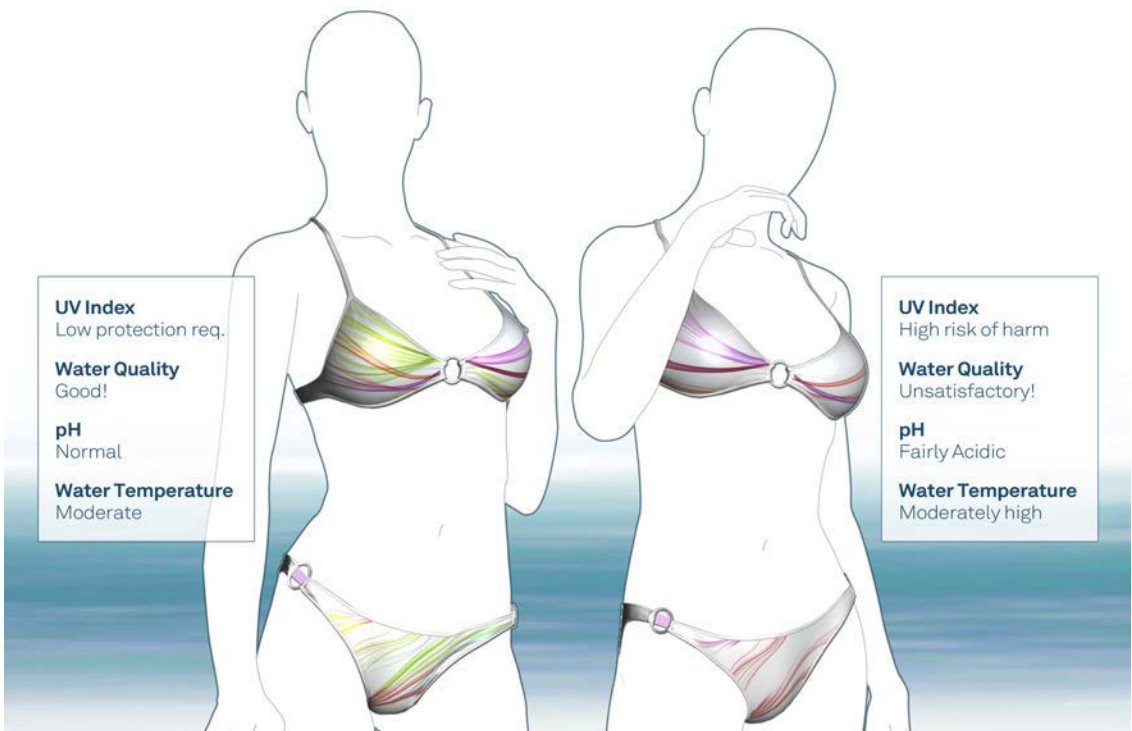

PERSONAL INTERACTIONS

Swimwear is undoubtedly the fashion representation of Rio's life and often the only thing that beach-goers will ever bring to the beach. Many people who are native to Rio are also used to wearing their swimwear around the city even for non-water related activities.

SENSEable Beachwear is the most fashionable sensing tool that serves as your personal colorimeter of UV and water quality. The SENSEable Beachwear will not look dissimilar from a typical bikini or speedo. However its design is just a lot cooler. Thanks to the body of research on wearable electronics, water-quality sensors and batteries can now possibly be embedded and should look like a natural part of the swimwear. These sensors will be able to instantly measure pH, temperature and conductivity to get a sense of the level of water purity. This data will be analyzed and immediately presented with color and pattern changes on the swimwear. In addition, SENSEable Beachwear will also perform as your personal UV indicator with UV-responsive materials.

SENSEable Beachwear will be your fashionable, personal colorimeter advising about water quality and UV level.

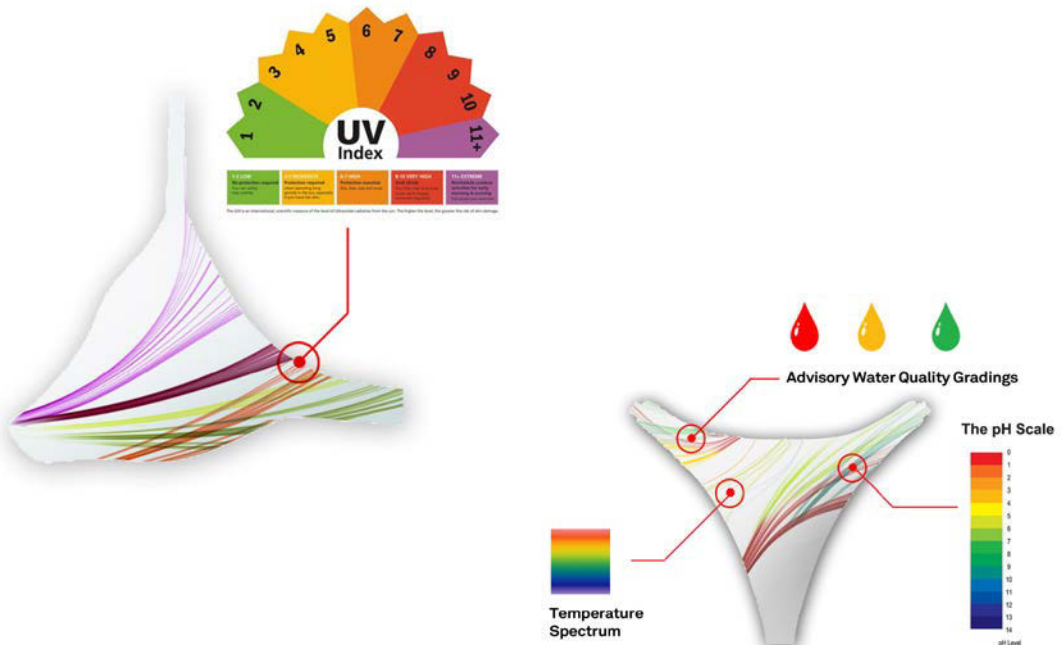



As the name indicates, one important feature of Beach-Fashion-Sense is the possibility of designs customization. If you decide to volunteer for the project, you can customize your own SENSEable Beachwear from a collection of designs and find one that suits your personal style. Furthermore, parameters including pattern, cutting, color palette, some design details and dimensions, can also be customized to fit your need. This interactive customize-your-own-swimwear interface can be accessible through the internet on your smart phone or personal computer.

Volunteers will customize their own design of SENSEable Beachwear with the interactive interface.

URBAN INTERACTIONS

The project's role as a media is clear. It is true that the mission will duplicate the duty of studying the water that the government and utility company may also perform. The advantage of having individuals participate not only improves the surveillance of water, but also helps promote environmental awareness through accessible and user-friendly data visualization for the general public.

The Beach-Fashion-Sense MAP will be available through social-networking channels and get dissipated through the infinite branching of relationships. For example, if you go to a beach, your geographical information and the beach pattern recognition data will be matched and posted on the social network which your friends can comment on and discuss.

Not only does Beach-Fashion-Sense WEB rate each beach based on water quality, but more importantly it will promote the best beaches. Beach-Fashion-Sense WEB will help people decide which beach they should visit, potentially leading to new useage patterns of Rio's beaches based on their overall environmental conditions. Data visualization will redistribute the demand among the beaches.

The general public will be interested in easily understanding the water-quality of their destinations at a glance (short-term), whilst the government will be interested in information that identifies the sources of problems and the distribution of demand for smarter city-planning (long-term).

Since the tools are so user-friendly, the project will not only attract environmental activists, but also individuals who are socially responsible and who seek heightened environmental awareness.

Images captured at the beach will be analyzed with high definition pattern recognition technology producing map data.

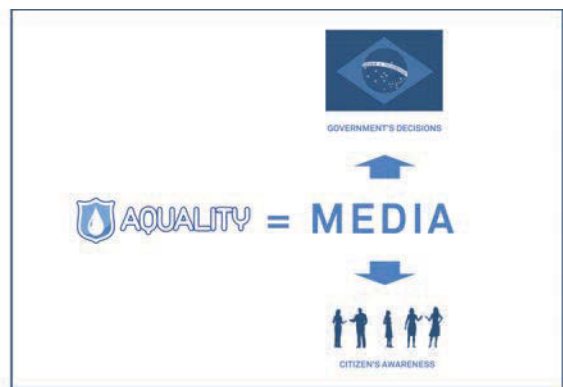

You carry out water assessment during your daily activities in Rio, therefore the frequency of assessment is always relative to the demand of water. In other words, the urban-scale sensing network is powered by individuals.

The project role as a "media" is clear. It is true that the mission will duplicate the duty of studying the water that the government and utility company may also perform. The advantage of having individual's participation not only parallels the surveillance of water, but also helps promote environmental awareness through accessible and user-friendly data visualization for the general public.

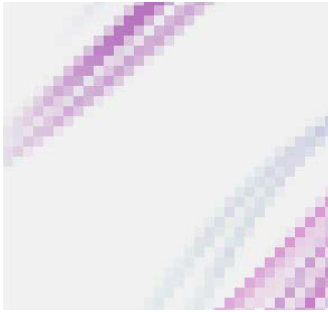
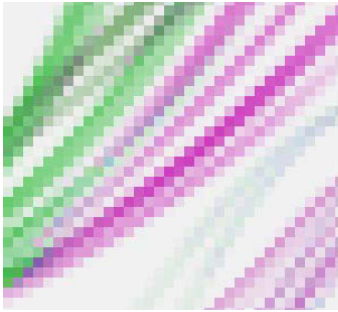

Difference in Pattern



Scenerio - Potential Danger

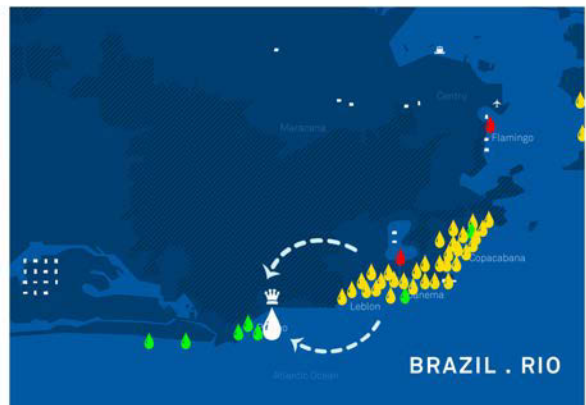

Scenerio - Discovering Better Beaches

TECHNOLOGY DESCRIPTION

WEARABLE ELECTRONICS PRECEDENTS

There has been a body of research for wearable and textile electronics. At MIT Media Lab, the High-low-tech group has been exploring the technology and application of textile electronics. A range of research products including conductive threads and cloth, pressure sensing fabric, bendable chips, techniques of knitting LED with fabric could be essential to the fabrication of a sensing swimsuit. Other precedents including products of Textronics and Pearl Izumi who embed responsive sensors and even MP3 player in their sportswear. Fashioningtech.com and talk2myshirt.com have also been blogging about research on wearable technologies.

WATER QUALITY SENSOR

The water quality can be sensed through physical and chemical tests with silver-plated nylon electrodes. Results include temperature, conductivity and pH, which collectively describe or predict the quality of water.

The data collected will be fed to the processing module and presented on the electrochromatic polymer strips through minimal electric currents. These strips will change colors when this tiny current passes through them. These strips create the pattern on the swimwear while the color changes will continue to animate the pattern.

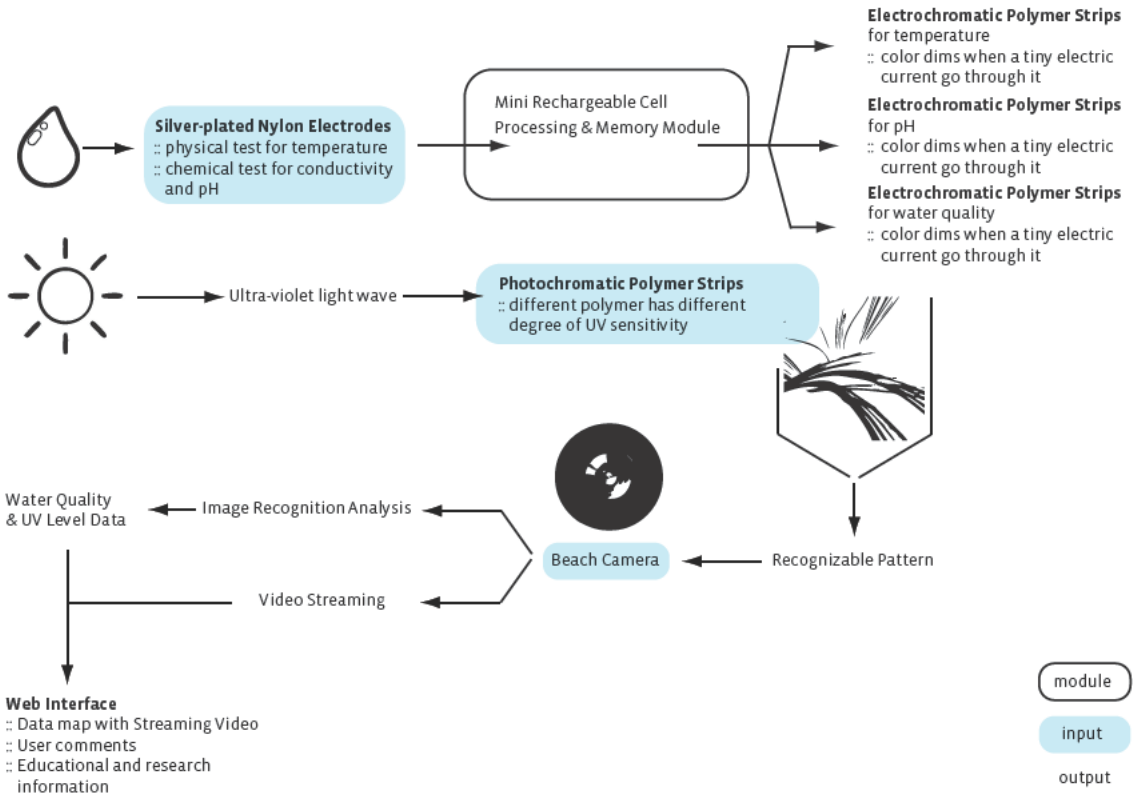

ULTRA-VIOLET SENSING

UV-level will also be presented with color changes in the pattern of the fabric. However the mechanism will be more direct. The color change is enabled by photochromatic polymer strips that change color directly related to the degree of UV. A series of UV-sensitive polymer strips are already available in the market which undergo different color changes and possess different degrees of UV sensitivity.

IMAGE RECOGNITION

Rather than setting up a wireless connection between the swimwear and the internet, the color patterns will be directly recognized by a high-definition beach camera. Through a recognition algorithm, these images will be analyzed and mapped to produce generalized results that indicate the water quality and UV level of a geographical region.

DATA BROADCAST

The data collected will be broadcasted through the internet to other beach-goers to advise them about water quality and UV levels in real time.

The data will also be archived for future analysis that affects city planning decision and policy on water improvement.

MATERIAL COMPOSITION

- SPANDEX
- REGULAR ELECTRONICS
- PHOTOCROMIC POLYMER
- ELECTROCHROMIC POLYMER
- SILVER-PLATED NYLON & METALLIC YARN
- NYLON

PHOTOCROMIC POLYMER
(REF: PPG INDUSTRIES OHIO, INC)

Nc1ccc(cc1)Cc2ccc(N)cc2

ELECTROCHROMIC POLYMER

BATTERY & PROCESSING UNIT

SILVER-PLAYED NYLON ELECTRODES

CONDUCTIVE METALLIC YARN

TECHNOLOGY ANATOMY

ELECTROCHROMIC POLYMER
(REF: BEAUFITFUL PHOTO-CHEMISTRY)

1.8V 0.8V 0.2V -1.2V

TBT

EXPORTING THE OLYMPIC SPIRIT

The project is not confined to the city of Rio. The world-class events will bring millions of people from all parts of the world in a great rendezvous at one place. After each event, our volunteers will bring their SENSEable swimwear to other places in the world, gradually expanding the SENSEable territory from the city of Rio to the seven continents.

The upcoming Olympics is framed by the issue of sustainable ecology. The philosophy of Beach-Fashion-Sense is indeed promoting the spirit of the Olympics. Broadcasting the collection of data in the internet via Beach-Fashion-Sense WEB and social networks will begin to assess the state of the world's beaches. If this creates media pressure and impacts



tourism, governments will have more incentive to improve the quality of their beach water.

Collaboration with environmental activists such as Greenpeace and Friends of the Earth would also bring more volunteers and more attention to Beach-Fashion-Sense.

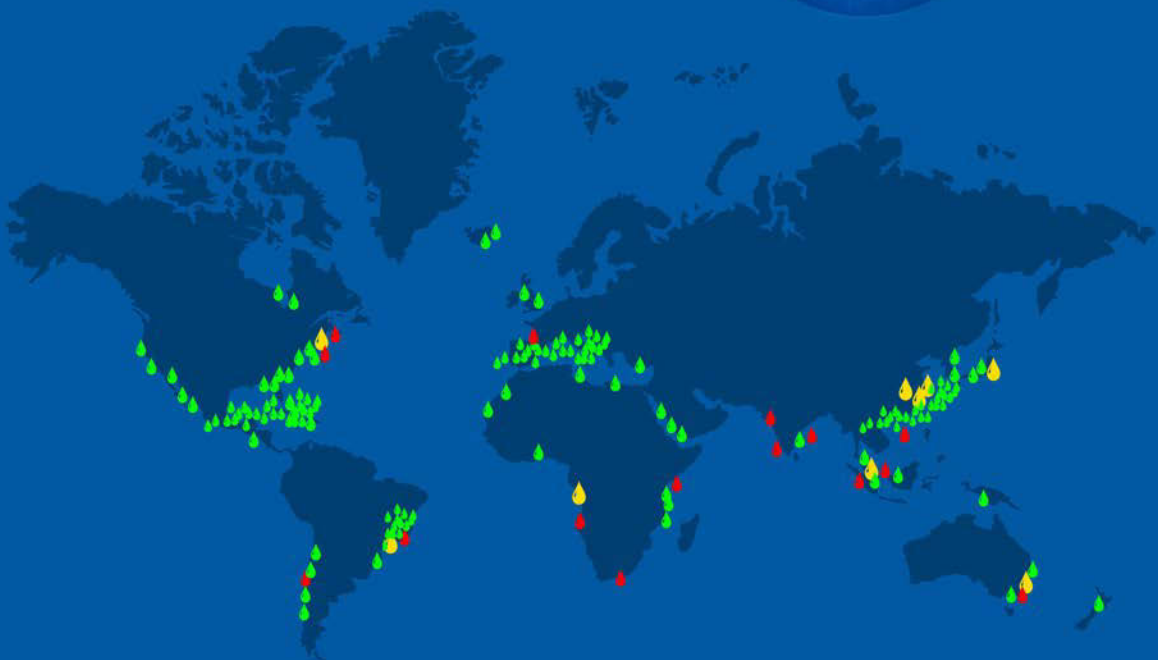

OTTO CL NG

Otto Ng is a Master of Architecture student at MIT and a researcher at SENSEable City Laboratory. Working across disciplinary boundaries, he engages in design, research and consultation in architecture, urban planning, computer science and social network media.

His academic research focuses on developing programmable tectonics - a computational design and material research that couples the processes of parametric form generation (program) and dynamic material and structural system (tectonics) - an alternative morphogenetic approach to architectural design.

Most of his works have attempted to explore new tectonic and planning possibilities with emerging technologies and embed intelligence in architecture and urbanism, through researches in digital cities, collective intelligence, robotics and kinetics, geometry algorithm, design scripting, digital fabrication and electronic prototyping.

Prior to MIT, Otto studied architecture at the University of Hong Kong. He also practiced at multiple design offices including Richard Rogers Partnership and Foster + Partners where he specialized in structure and envelop design through digital modeling, scripting and simulations.



www.ottocad.net

