

Sensors & Imaging

Low Defect Coating Solutions for Optical Sensor Applications



Enabling Innovative Optical Solutions

Innovation is part of our tradition

It was at the suggestion of the ruling Prince Franz Josef II of Liechtenstein that Dr. Max Auwärter – in cooperation with Emil G. Bührle – founded the company Balzers in the village of Balzers, in the Principality of Liechtenstein, in 1946. At that time the technology of vacuum deposition was still in its early stages. With very few exceptions, high vacuum systems were being used only in research laboratories.

Due to the lack of commercially available high vacuum equipment, Balzers had to design and build most of the required vacuum components, equipment and systems necessary for the development of its novel and proprietary thin-film coating processes.

Today Optics Balzers is a globally recognized leader in customized optical thin-film coatings and components for the photonics industry. The company possesses a broad and in-depth know-how in optical thin-film coating processes, complemented by sophisticated patterning, glass bonding and sealing, and further processing capabilities necessary for producing optical thin-film coated components up to optical subassemblies. Highly experienced and skilled development and engineering teams closely collaborate with customers to develop innovative solutions meeting their specific requirements. The combination of these capabilities and skills places Optics Balzers at the forefront of markets in the photonics industry such as Automotive, Biophotonics, Laser, Space & Defence, Lighting & Projection, Industrial Applications, and Sensors & Imaging.

Optics Balzers' continuous innovation, quality improvements, additions of expertise and production sites in Liechtenstein and the EU, will continue to support customers' novel product development efforts with Optics Balzers as a trusted, reliable, and innovative partner.



Sensors & Imaging Solutions

Our optical components guide, reflect, select and alter light for all applications of semiconductor devices.

Silicon based devices such as MEMS, CCD/CMOS sensors or LCOS microdisplays are packaged with cover glasses. These cover glasses consist of clean surfaces plus functional coatings – such as AR coatings, NIR blocking filters or index matched ITO. Where needed chrome apertures can be provided, as well as solderable frames, B-stage epoxy frames or soldered Kovar lids as packaging solutions. Depending on the final application the choice of material can be very important. Optics Balzers has experience with coatings on a broad variety of glass substrates, such as borosilicate, filter glasses, sapphire, etc.

A key factor of Optics Balzers' sensor lids is the superior low defect properties of the coatings as they define the quality of the device. Sealing or bonding solutions for the subsequent assembly process are an integral part of the products offered.

Some sensor applications have less stringent defect requirements and solutions can be provided with the same functionality but with a cost-effective adjusted quality performance.

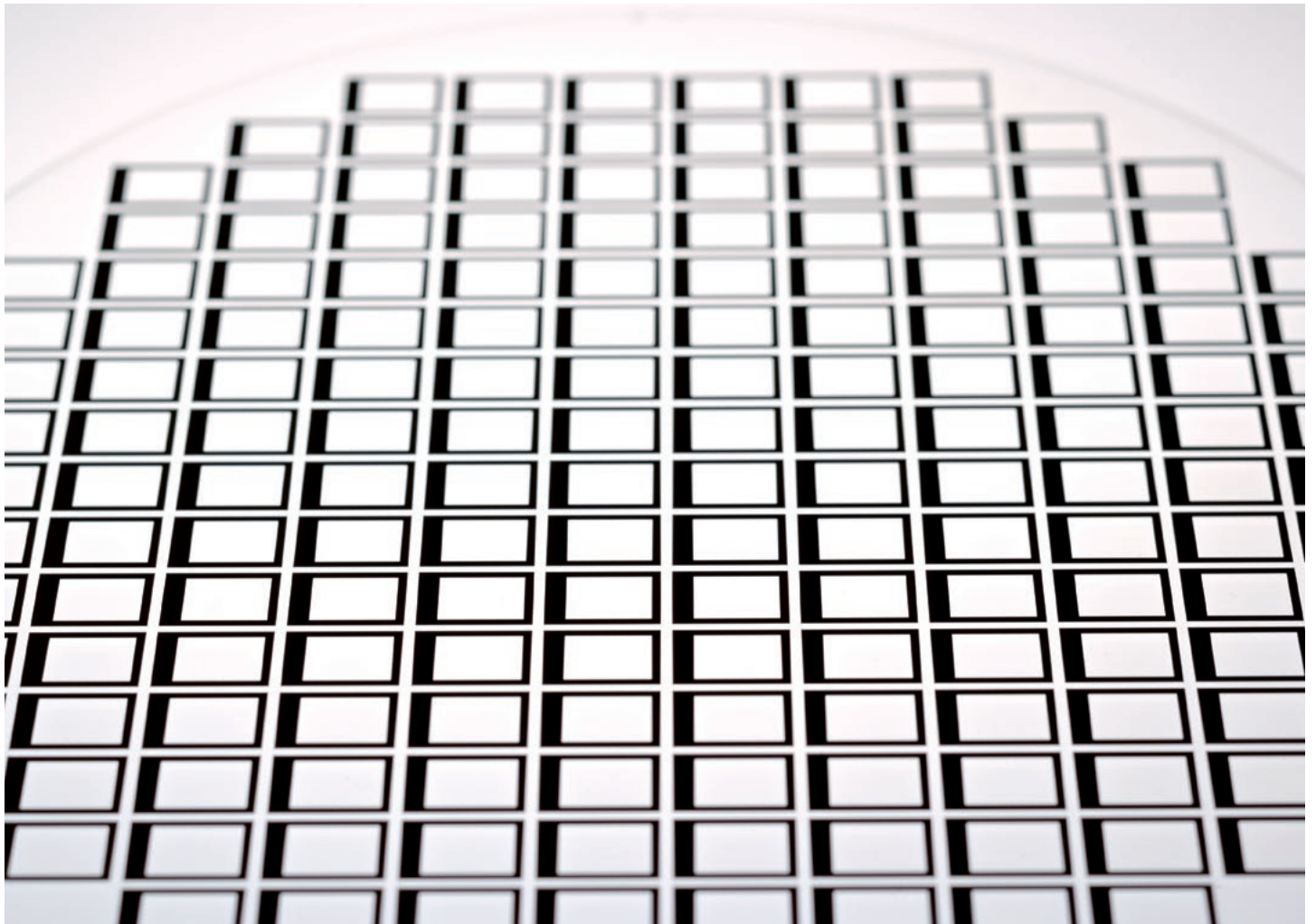

Cover Glass Solutions

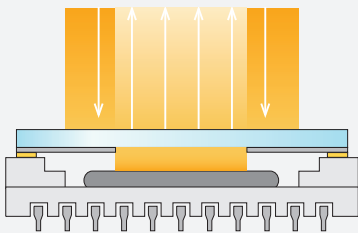
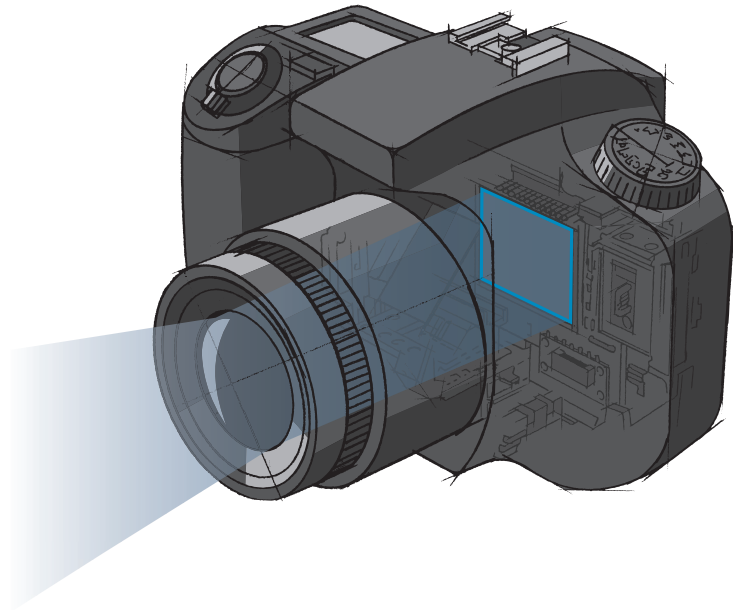

Cover Glass Function

- Efficient transmission of light and blocking of parasitic radiation – low defect anti-reflection coatings or filter coatings
- Protection of the devices – standard and special glass types
- Sealing of the devices – B-stage epoxies, solderable coatings, other sealing technologies upon request.
- Masking and shielding of light path – chromium frames and apertures

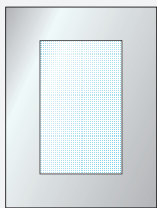

Individual Substrate Processing

Single part processing of optical lids is the premier solution whenever cleanliness and high flexibility for customized sizes and patterns are required. The lid substrates are individually processed in final size to avoid dicing steps which are critical with respect to low defect requirements.

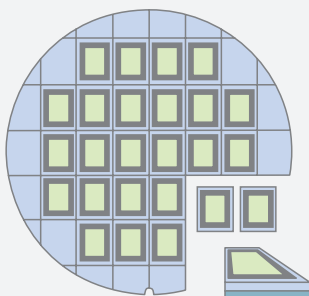

Wafer Level Processing

A coated glass wafer is the cutting edge technology for high volume optical packaging. The glass wafer is bonded to the silicon wafer before dicing. Some of the applications require a spacer between the two wafers. Optics Balzers provides glass wafers with low defect optical coatings – if required with chrome apertures for light beam shaping. Component dicing and edging to the final size and specification can also be offered after coating for cost-effective solutions wherever it can be tolerated by the requirements.

Optical Coatings & Components

The core competencies of Optics Balzers are the design and manufacture of high precision thin-film optical coatings and integrating them into sophisticated optical components. Optics Balzers' coatings and components are characterized by excellent spectral performance, low defect quality and superior environmental stability. The coatings are produced with state-of-the-art evaporation and sputtering equipment platforms with process and product specific adaptations. The components are both customized to the specific product requirements and optimized for high yield production. Continuous process control like monitoring of the coating process or customer specific component characterization ensures consistent and high quality in volume manufacturing.

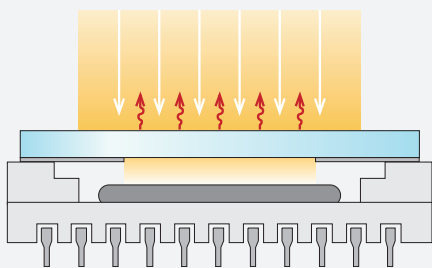

Low Defect Anti-Reflective Coatings

Optical coatings on lids for high performance digital image sensors require very low densities of small defect sizes. Broadband anti-reflective coatings with low residual reflections and spectrally neutral performance eliminate ghost effects.

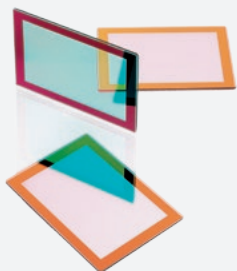

Filter Coatings

Filter coatings with efficient near infrared (NIR) and optional ultraviolet (UV) blockings tightly limit the sensors' response to the visible wavelength range. Details of spectral filter characteristics and wavelength ranges are optimized for customer specific requirements and applications.

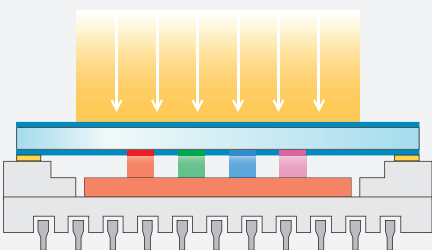

Patterned Dichroic Filters

Multispectral image sensors require cover glass lids with integrated color selective dichroic filters. Optics Balzers provides patterned color filters for selective spectral filtering on different zones of the cover glass lids. Such dichroic filters may include R/G/B Filters or monochrome UV or IR Filters. The individual filter zones may be masked with an opaque chrome layer containing alignment marks.

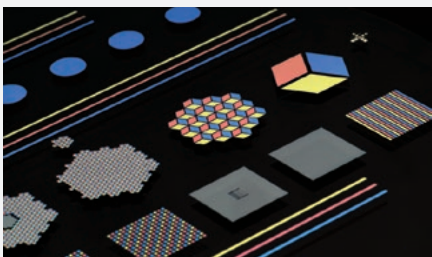

Micro-Patterned Interference Filters on Wafer

The spectral response of photodiodes, phototransistors or CMOS sensors can be modified by micro-patterned interference filter coatings. The coatings are applied by photolithographic technology on 2 to 8 inch wafer sizes. Bondpads are kept free. The high positioning accuracy allows several filters to be deposited onto adjacent photodetectors on a die.

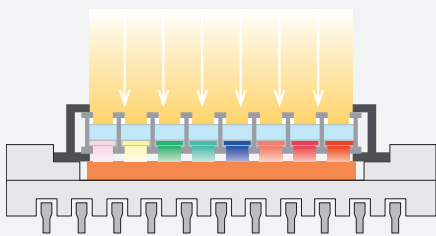

Self-blocking VIS and SWIR Bandpass Filters

VIS and SWIR bandpass filters with self-blocking filter design for spectral sensing and imaging combine wide blocking and high passband transmittance in a single all-dielectric interference coating. They feature extreme stability in terrestrial and space environments and are customized for Si, InGaAs or HgCdTe sensor applications.



Patterned Chrome

Chrome patterns on planar components are widely used in the optical and semiconductor industry. Optics Balzers puts its emphasis on high resolution, low defect patterns – optionally in combination with low defect functional coatings. With CrBlack™ coating, Optics Balzers additionally offers an optical black coating, characterized by high absorption and low reflection in the VIS range.



ITO Coatings

Premium quality indium tin oxide (ITO) coatings with high transmission and low resistivity are based on dedicated sputtering processes. The ITO layer may be supplemented with dielectric layers for index matching or for obtaining anti-reflective properties of the coating. Applications include surface heated cover glasses to prevent condensation or EMI shielding to improve the quality of the sensor.

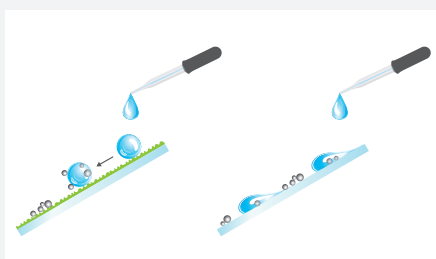

TopFlex™ Hydrophobic Coatings

TopFlex™ hydrophobic coatings are chemically resistant to water, oil and grease. This UV to IR transparent top-layer is easy to clean and also dirt-repellent. The coating exhibits a good adherence to the substrate and other coatings and is highly resistant to various forms of cleaning processes.

Coating Plus: More Than Just Coating

Sophisticated optical thin-film components and subsystems require additional process steps beyond coating.

Bonding and Sealing

Light sensitive semiconductor devices require protection by applying a transparent glass lid. Optics Balzers offers bonding and sealing technologies along the entire value chain of optical sensors – ready for assembly and if required with integrated optical aperture.

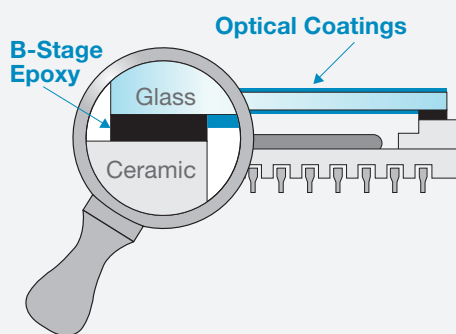

B-Stage Epoxy

A B-stage epoxy frame on the lid facilitates the assembly process: The epoxy is provided in the dry state and is cured by simple tempering at 100°C – 130°C. The epoxy is applied to the lids in a way which allows for precise patterns and high cosmetic standards.

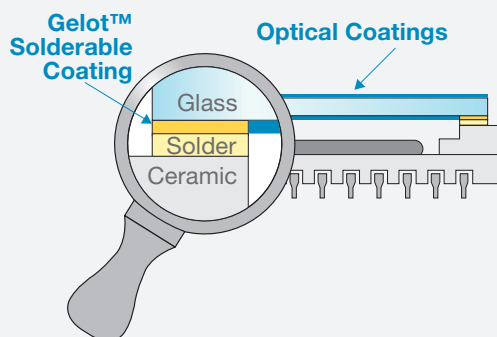

Gelot™ Solderable Coatings

Soldering is the assembly technology which provides best hermeticity values of such packaging. Gelot™ solderable coating gives the glass a surface with good adhesive properties for soldering with materials such as gold or palladium. Gelot™ is applied to the lid as a frame pattern with a clear aperture.

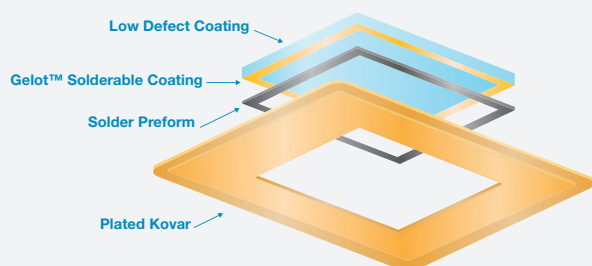

Soldered Kovar Lids

On top of the Gelot™ solderable coating an assembled glass-to-metal solution can be offered to satisfy stringent hermetic requirements. The soldered Kovar Lids are the first choice for demanding applications such as sensors in space or in the shortwave infrared range.

Patterning

Optics Balzers offers patterning solutions for high quality optical components. Depending on the product and its applications, various patterning techniques such as photolithography, laser ablation or masked coatings are available to meet a broad range of customer requirements for feature sizes and shapes. The lift-off technology allows the deposition of filter arrays onto cover glasses or directly onto photodetector wafers.

Photolithography

Photolithography capabilities such as lift-off and etching techniques allow the production of precision patterned coatings and submicron gratings. The photolithography techniques are specifically used in producing masked cover lids for MEMS devices and CCD/CMOS image sensors.

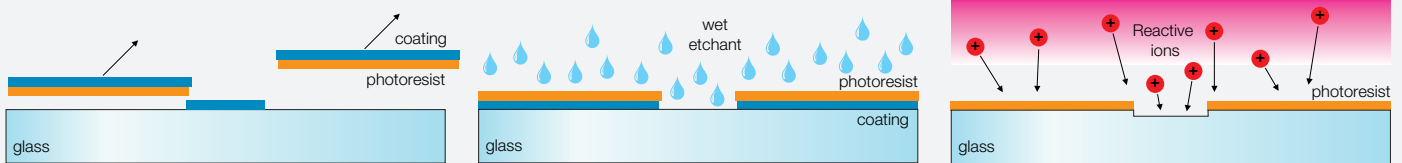

Masked Coatings

Precision etched metal masks attached to the substrates provide patterned coatings during the coating process. While the achievable feature sizes and shapes are limited with direct masking, patterning can be applied with almost any coating process and coating material, also with processes that require higher temperatures.

Marking

Application of thin-film optical components may require unambiguous marking and labeling, either on the substrate surface or on the coating. The pattern can be generated according to customers' specific needs.

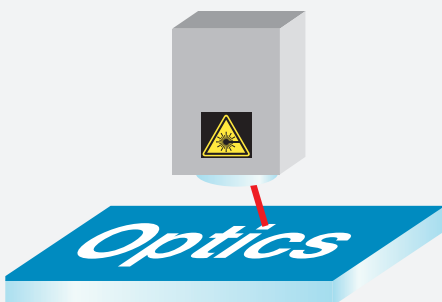

Laser Ablation

Laser ablation offers novel opportunities in patterning of optical filter coatings. By using adapted processes for each specific application, high precision patterns can be produced on the coated components. Laser ablation offers excellent flexibility for customized shapes and patterns together with high speed processing capabilities.

Coating Plus: More Than Just Coating

Glass Processing

Economical production of thin-film coated components often requires wafer based substrate processing. Low defect substrates additionally require clean edge work to prevent glass chipping. With its advanced dicing and scribing capabilities, Optics Balzers manufactures thin-film components with high precision to customer specific shapes and sizes, optionally with chamfered edges.

Varnishing

High-accuracy dispensing technologies enable continuous or selective blackening of optical parts and complement the low reflection, high absorption coating portfolio from Optics Balzers.

Subassembly

Optics Balzers offers customized optical subassemblies to support its customers' ever increasing demands. We develop individual solutions for and together with our customers.

Volume Production

The utilization of high-tech singulation equipment paired with sophisticated manufacturing processes allow for a cost-effective mass production of optical parts with small physical dimensions.

Packaging and Handling

Customized packaging and shipping ensures top quality in surface protection and cleanliness during transportation and in subsequent process steps at the customer's site.

Development Partners

Optics Balzers relies on strong partnerships. Therefore our competence centers in Liechtenstein and Germany count on the close cooperation with scientific institutes, universities, and colleges. Those partnerships allow our teams of engineers to develop innovative solutions, tailored to the individual requirements of our customers.

Project Management

Challenging projects with demanding product properties can be realized successfully only by high level organized and well educated project management teams. Therefore Optics Balzers supports your product request with a dedicated project team, to bring your idea into a real success story. Close cooperation, a permanent exchange of information, and at last but not least, a company with tradition, are the basic elements for a strong long-term partnership.

Applications

Digital Imaging

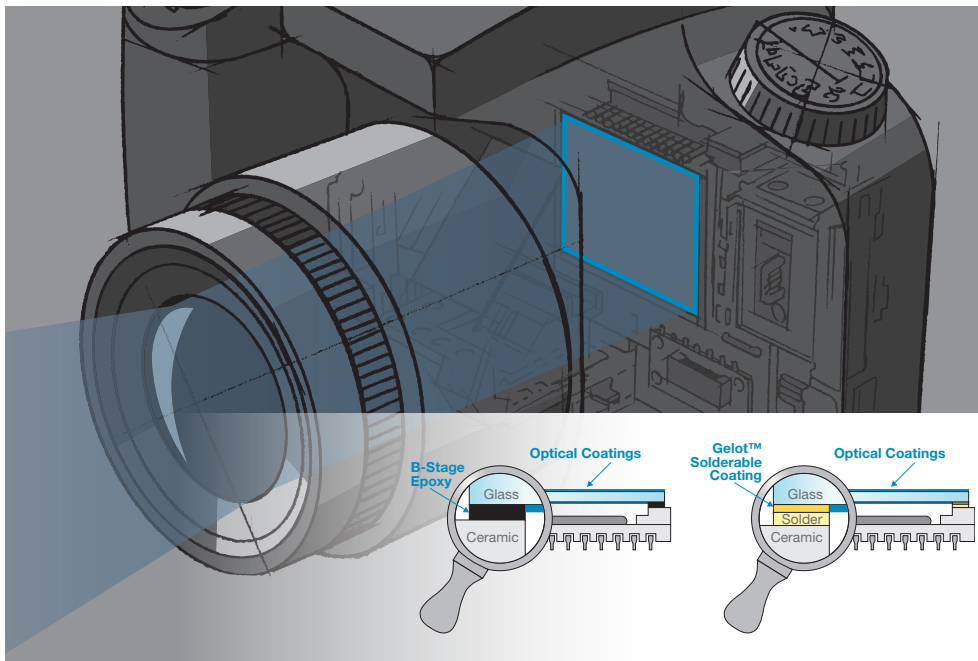

Earth Observation

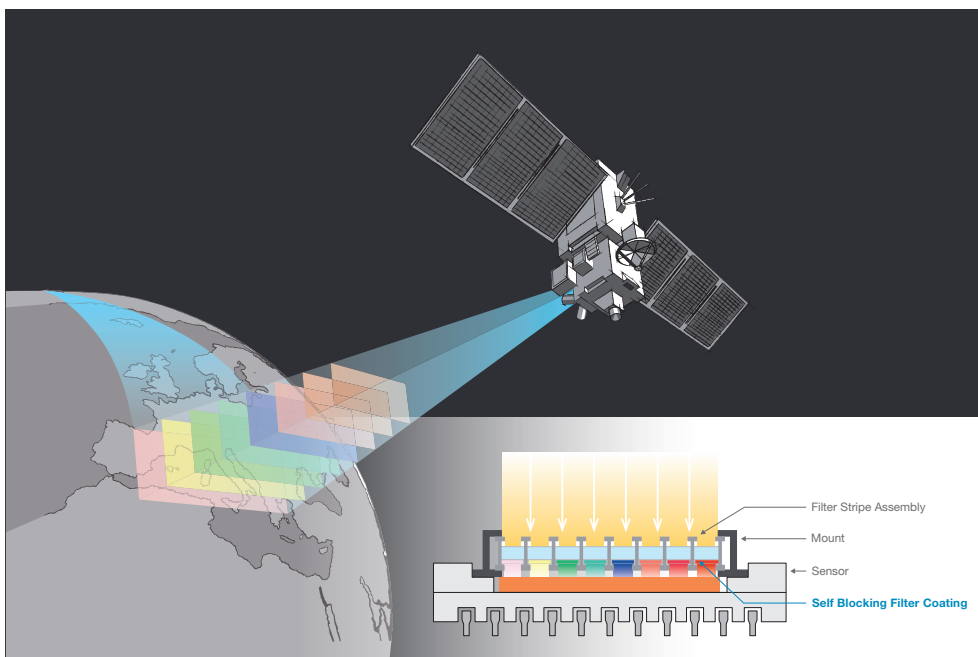

Headquarters

Optics Balzers AG

Neugrüt 35
LI-9496 Balzers
Liechtenstein
T +423 388 9200
F +423 388 9390
info@opticsbalzers.com

Optics Balzers Jena GmbH

Otto-Eppenstein-Strasse 2
DE-07745 Jena
Germany
T +49 3641 3529 30
F +49 3641 3529 35
info.jena@opticsbalzers.com

Sales Offices

Europe

Optics Balzers GmbH
Mergenthalerallee 73-75
DE-65760 Eschborn
Germany

France

Optics Balzers – Bureau Français
1, Avenue des Jades, CS 73837
FR-44338 Nantes Cedex 3
France

Switzerland/Austria

Optics Balzers AG
Neugrüt 35
LI-9496 Balzers
Liechtenstein

USA/Canada

Optics Balzers USA Inc.
11941 W 48th Avenue
Suite 100
Wheat Ridge, CO 80033
USA

Asia

Optics Balzers AG
12 Marina Boulevard
#17-01 Marina Bay
Financial Centre Tower 3
Singapore, 018982