

**SEPTEMBER 2017**

**DR. Z's CORNER**

*Conquering the FE & PE exams  
Problems, Solutions & Applications*

**This month's topics:**

- **NCEES Calculator Policy for Current FE & PE Exams**
- **FE CIVIL Exam Topics & Number of Questions**
- **PE CIVIL Exam Topics & Number of Questions**
- **Transportation Engineering, *Dr. Bryan Higgs***
- **Geotechnical Engineering, *Dr. Lei Wang***
- **Structures and Computers, *Dr. Vagelis Plevris***
- **Hydraulics, Open Channel Flow (Rectangular & Trapezoidal)**
- **Hydraulics, Applications of Manning's Equation**
- **Engineering Economics, Future Worth, Present Worth**
- **Steel Design, Compression Members**
- **Mechanics of Materials, Axially Loaded Members**
- **Mechanics of Materials, Centroids & Moments of Inertia**
- **Analytical Geometry, Vectors & Matrices**
- **Structures, Analysis of Determinate Beams & Trusses**
- **Structures, Deflections of Beams & Trusses**
- **Structures, Indeterminate Beams**
- **Reinforced Concrete, Load Factors & Combinations**

# **NCEES CALCULATOR POLICY**

## **FOR CURRENT FE & PE EXAMS**

To protect the integrity of its exams, NCEES limits the types of calculators you may bring to the exams. The only calculator models acceptable for use during the FE & PE exams are as follows.

### **Casio:**

All fx-115 models. Any Casio calculator must contain fx-115 in its model name.

Examples of acceptable Casio fx-115 models include:

- fx-115 MS
- fx-115 MS Plus
- fx-115 MS SR
- fx-115 ES
- fx-115 ES Plus

### **Hewlett Packard:**

The HP 33s and HP 35s models, but no others.

### **Texas Instruments:**

All TI-30X and TI-36X models. Any Texas Instruments calculator must contain either TI-30X or TI-36X in its model name. Examples of acceptable TI-30X and TI-36X models include (but are not limited to):

- TI-30Xa
- TI-30Xa SOLAR
- TI-30Xa SE
- TI-30XS Multiview
- TI-30X IIB
- TI-30X IIS
- TI-36X II
- TI-36X SOLAR
- TI-36X Pro

# **PRINCIPLES & PRACTICE OF ENGINEERING**

## **(NCEES - Current Exam Topics)**

### **P.E. EXAMINATION / Transportation & Geotechnical**

According to NCEES the new civil P.E. exam is a *breadth* and *depth* examination. This means that examinees work the breadth (AM) exam and one of the five depth (PM) exams. The five areas covered in the civil examination are construction, geotechnical, structural, transportation, and water resources and environmental. The breadth exam contains questions from all five areas of civil engineering. The depth exams focus more closely on a single area of practice in civil engineering.

Examinees work all questions in the morning session and all questions in the afternoon module they have chosen. Depth results are combined with breadth results for final score. The exam is an 8-hour open-book exam. It contains 40 multiple-choice questions in the 4-hour AM session, and 40 multiple-choice questions in the 4-hour PM session. The exam uses both the *International System of Units* (SI) and the *US Customary System* (USCS).

### ***TRANSPORTATION BREADTH EXAM***

#### **Exam Topics & Approximate Number of Questions:**

- I. *Project Planning (4 questions)*
- II. *Means and Methods (3 questions)*
- III. *Soil Mechanics (6)*
- IV. *Structural Mechanics (6)*
- V. *Hydraulics and Hydrology (7)*
- VI. *Geometrics (3)*
- VII. *Materials (6)*
- VIII. *Site Development (5)*

### ***TRANSPORTATION DEPTH EXAM***

#### **Exam Topics & Approximate Number of Questions:**

- I. *Traffic Engineering (Capacity Analysis and Transportation Planning) (11 questions)*
- II. *Horizontal Design (4 questions)*
- III. *Vertical Design 4*
- IV. *Intersection Geometry 4*
- V. *Roadside and Cross-Section Design 4*
- VI. *Signal Design 3*
- VII. *Traffic Control Design 3*
- VIII. *Geotechnical and Pavement 4*
- IX. *Drainage 2*
- X. *Alternatives Analysis 1*

# **PRINCIPLES & PRACTICE OF ENGINEERING**

## **(P.E) EXAM for CIVIL ENGINEERS**

### **(Geotechnical Engineering)**

According to NCEES the civil exam is a breadth and depth examination. This means that examinees work the breadth (AM) exam and one of the five depth (PM) exams. The five areas covered in the civil exam are construction, geotechnical, structural, transportation, and water resources and environmental. The breadth exam contains questions from all five areas of civil engineering. The depth exams focus more closely on a single area of practice in civil engineering.

Examinees work all questions in the morning session and all questions in the afternoon module they have chosen. Depth results are combined with breadth results for final score. The exam is an 8-hour open-book exam. It contains 40 multiple-choice questions in the 4-hour AM session, and 40 multiple-choice questions in the 4-hour PM session. The exam uses both the International System of Units (SI) and the US Customary System (USCS).

### ***GEOTECHNICAL BREADTH EXAM***

#### **Exam Topics & Approximate Number of Questions:**

- I. Project Planning (4 questions)*
- II. Means and Methods (3 questions)*
- III. Soil Mechanics (6)*
- IV. Structural Mechanics (6)*
- V. Hydraulics and Hydrology (7)*
- VI. Geometrics (3)*
- VII. Materials (6)*
- VIII. Site Development (5)*

### ***GEOTECHNICAL DEPTH EXAM***

#### **Exam Topics & Approximate Number of Questions:**

- I. Site Characterization (5 questions)*
- II. Soil Mechanics, Laboratory Testing, and Analysis (5 questions)*
- III. Field Materials Testing, Methods, and Safety (3)*
- IV. Earthquake Engineering and Dynamic Loads (2)*
- V. Earth Structures 4*
- VI. Groundwater and Seepage 3*
- VII. Problematic Soil and Rock Conditions 3*
- VIII. Earth Retaining Structures (ASD or LRFD) 5*
- IX. Shallow Foundations (ASD or LRFD) 5*
- X. Deep Foundations (ASD or LRFD) 5*



*Bryan Higgs, Ph.D.*  
*Assistant Professor*  
*University of the District of Columbia*  
*School of Engineering and Applied Sciences*  
*Department of Civil Engineering*  
*4200 Connecticut Avenue, NW*  
*Washington, D.C. 20008*  
*Tel: 202-274-6600*  
**Email:** [bryan.higgs@udc.edu](mailto:bryan.higgs@udc.edu)

### **Career Highlights:**

- 1- Ph.D., M.S., B.S. all from Virginia Tech
- 2- Published 32 papers in peer-reviewed journals and conferences
- 3- **Intelligence Community Postdoctoral Research Fellow**,  
“Discovering the Vulnerable Physical Routes in a Network,”
- 4- **Principal Investigator**, “Assessment of Sustainability in Transportation Network Design using Game Theory,” UDC Faculty Incentive Grant
- 5- **Postdoctoral Researcher**, “I-65 Corridor Feasibility Study,” Tennessee Department of Transportation
- 6- **Graduate Research Assistant**, “Driver Behavior in Traffic,” Federal Highway Administration – Exploratory Advanced Research
- 7- **Member**, American Society of Civil Engineers
- 8- **Member**, American Society for Engineering Education
- 9- **Member**, Institute of Transportation Engineers
- 10- **Friend**, several Transportation Research Board Committees
- 11- **Scholarly Article Reviewer**, Transportation Research Part C: Emerging Technologies
- 12- **Scholarly Article Reviewer**, Biological Psychology
- 13- **Scholarly Article Reviewer**, IEEE Transactions on Vehicular Technology
- 14- **Scholarly Article Reviewer**, Advances in Mechanical Engineering
- 15- **Scholarly Article Reviewer**, IEEE Intelligent Transportation Systems Conference
- 16- **Scholarly Article Reviewer**, Transportation Research Board Annual Meeting
- 17- **Dissertation and Thesis Committee Member**, multiple occasions
- 18- **Volunteer**, Choosing Transportation Summit, MATHCOUNTS

**PROFESSIONAL ENGINEERING (P.E.)**  
**TRANSPORTATION DISCIPLINE**  
**HORIZONTAL CURVES**

**PREPARED  
BY  
DR. HIGGS**

**Problem 1**

Compute the minimum radius (ft.) of a circular curve for a highway design for 45 mph. Assume that the maximum *superelevation* is 13.8% and the coefficient of friction is 13.9%.

- (A) 463
- (B) 487.4
- (C) 511.7
- (D) 536.1

**Problem 2**

Compute the minimum radius of a circular curve for a highway design for 45 mph. Assume that the maximum *superelevation* is 10.6% and the coefficient of friction is 10.7%.

- (A) 570.4
- (B) 602.1
- (C) 633.8
- (D) 665.5

**Problem 3**

Compute the *superelevation* rate for a curve with a design speed of 50 mph, a radius of 1100 ft, and a coefficient of friction of 11.4%.

- (A) 0.034
- (B) 0.038
- (C) 0.041
- (D) 0.045

**Problem 4**

Compute the length of a horizontal curve with a radius of 1250 ft and an intersection angle of 110 degrees.

- (A) 2399.8
- (B) 2519.8
- (C) 2639.8
- (D) 2759.8

**FUNDAMENTALS OF ENGINEERING**  
**TRANSPORTATION**  
**HORIZONTAL CURVES**

SOLUTIONS  
BY  
DR. HIGGS

**Problem 1**

Compute the minimum radius (ft) of a circular curve for a highway design for 45 mph. Assume that the maximum superelevation is 13.8% and the coefficient of friction is 13.9%.

**Formulas**

$$0.01e + f = \frac{V^2}{15R}$$

Where:

$e$  - superelevation (%)

$f$  - side friction factor

$V$  - design speed (mph)

$R$  - radius of curve (ft)

**Solution**

$$R = \frac{V^2}{15(0.01e + f)} = \frac{45^2}{15(0.01 * 13.8 + 0.139)} = 487.4$$

## Problem 2

Compute the minimum radius (ft) of a circular curve for a highway design for 45 mph. Assume that the maximum superelevation is 10.6% and the coefficient of friction is 10.7%.

### Formulas

$$0.01e + f = \frac{V^2}{15R}$$

Where:

$e$  - superelevation (%)

$f$  - side friction factor

$V$  - design speed (mph)

$R$  - radius of curve (ft)

### Solution

$$R = \frac{V^2}{15(0.01e + f)} = \frac{45^2}{15(0.01 * 10.6 + 0.107)} = 633.8$$



### Problem 3

Compute the superelevation rate (%) for a curve with a design speed of 50 mph, a radius of 1100 ft, and a coefficient of friction of 11.4%.

### Formulas

$$0.01e + f = \frac{V^2}{15R}$$

Where:

$e$  - superelevation (%)

$f$  - side friction factor

$V$  - design speed (mph)

$R$  - radius of curve (ft)

### Solution

$$e = 100 \left( \frac{V^2}{15R} - f \right) = 100 \left( \frac{50^2}{15 * 1100} - 0.114 \right) = 0.04$$

## Problem 4

Compute the length of a horizontal curve with a radius of 1250 ft and an intersection angle of 110 degrees.

### Formulas

$$L = \frac{2\pi RI}{360}$$

Where:

$L$  - length of curve (ft)

$R$  - radius of curve (ft)

$I$  - intersection angle (degrees)

### Solution

$$L = \frac{2\pi * 1250 * 110}{360} = 2399.8$$



*Lei Wang, Ph.D., P.E.*  
*Assistant Professor of Geotechnical Engineering*  
*University of the District of Columbia*  
*School of Engineering and Applied Sciences*  
*Department of Civil Engineering*  
*4200 Connecticut Avenue, NW*  
*Washington, D.C. 20008*  
Email: [lei.wang@udc.edu](mailto:lei.wang@udc.edu)

## Career Highlights

1. Excellent Paper Award, Journal of GeoEngineering, Taiwan Geotechnical Society, 2015
2. Member of Chi Epsilon, National Civil Engineering Honor Society, 2014
3. Outstanding Graduate Researcher Award, College of Engineering and Science, Clemson University, 2013
4. Best Paper Award, Journal of GeoEngineering, Taiwan Geotechnical Society, 2013
5. Aniket Shrikhande Memorial Annual Graduate Fellowship, Clemson University, 2013
6. Editorial Board Member of four International Journals:
  - *International Journal of Geotechnical Engineering* (Taylor & Francis)
  - *Bulletin of Engineering Geology and the Environment* (Springer)
  - *Marine Georesources & Geotechnology* (Taylor & Francis)
  - *Geoenvironmental Disasters* (Springer)
7. Active in Research; Published 24 Papers in International Refereed Journals, and 16 Papers in Refereed ASCE Geotechnical Special Publications/International Conference Proceedings.
8. Reviewer of 19 International Journals.
9. 469 citations: "Google Scholar", with Author h-index=14.
10. Research Highlights Paper, ASCE Journal of Geotechnical and Geoenvironmental Engineering, January 2014
11. Multiple Top 25 hottest articles in Computers and Geotechnics (Elsevier)
12. Member of International Scientific Committee, Geo-Risk 2017 (6th International Symposium on Geotechnical Safety and Risk), American Society of Civil Engineers
13. Committee Member, Risk Assessment and Management (RAM) Committee, Geo-Institute, American Society of Civil Engineers
14. Served as a Geotechnical Engineer at WSP | Parsons Brinckerhoff, one of the world's leading civil engineering design firms
15. Served as Vice President, Western Branch, Montana Section, American Society of Civil Engineers

**GEOTECHNICAL ENGINEERING**  
**SOIL CONSOLIDATION PROBLEMS**  
PROFESSIONAL ENGINEERING (P.E.)

PREPARED  
BY  
DR. WANG

- (1) A clay layer with thickness of 6 ft is subjected to an increase in vertical stress of 800 psf at the center of the layer caused by a very wide embankment fill. Laboratory tests for the clay layer have indicated the clay has an initial void ratio of 1.0, a preconsolidation pressure of 1500 psf, a compression index  $C_c$  of 0.3 and a swell index  $C_s$  of 0.06. What is most nearly the ultimate consolidation settlement for this clay layer?

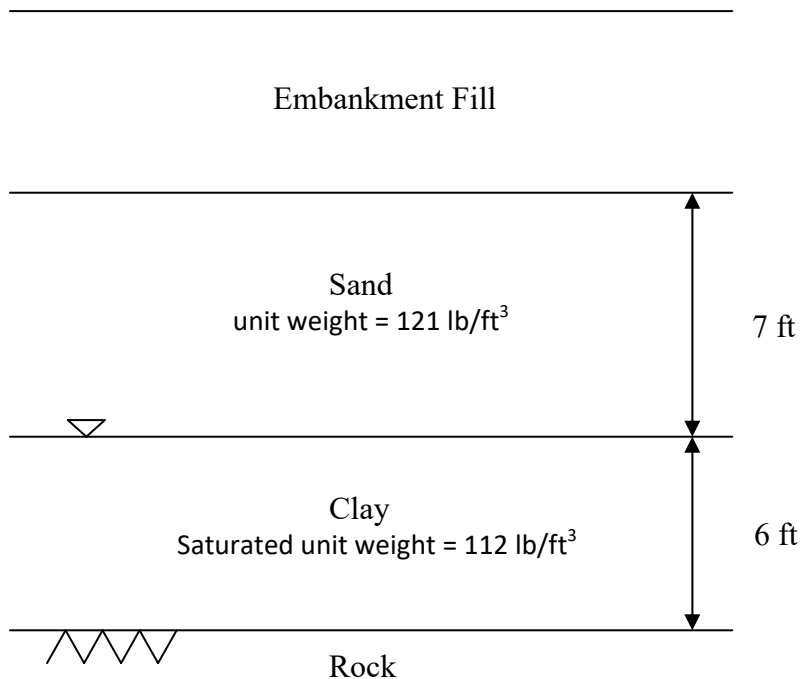

- (A) 1.0 in
- (B) 1.1 in
- (C) 1.2 in
- (D) 1.3 in

- (2) A clay layer with thickness of 6 ft is subjected to an increase in vertical stress of 600 psf at the center of the layer caused by a very wide embankment fill. Laboratory tests for the clay layer have indicated the clay is a normally consolidated clay, with an initial void ratio of 0.8 and a compression index  $C_c$  of 0.35. What is most nearly the ultimate consolidation settlement for this clay layer?

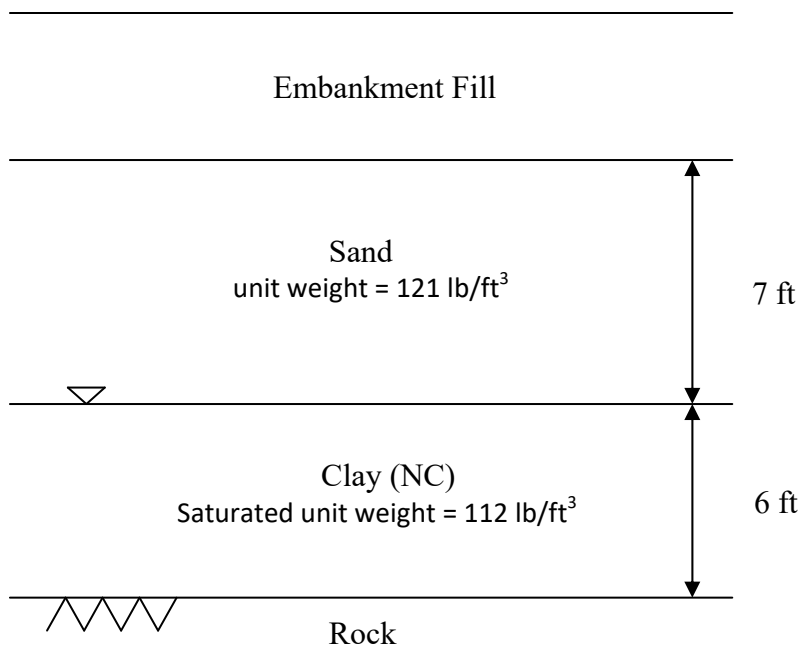

- (A) 2.8 in
- (B) 2.9 in
- (C) 3.0 in
- (D) 3.1 in

- (3) For the footing problem shown in the following figure, the average stress increase in the clay layer caused by the loads from footing is 800 psf. The clay layer is normally consolidated with a compression index  $C_c = 0.35$  and initial void ratio  $e_0 = 0.9$ . The calculated the primary consolidation settlement (at the end of consolidation) for this clay layer is mostly near to:

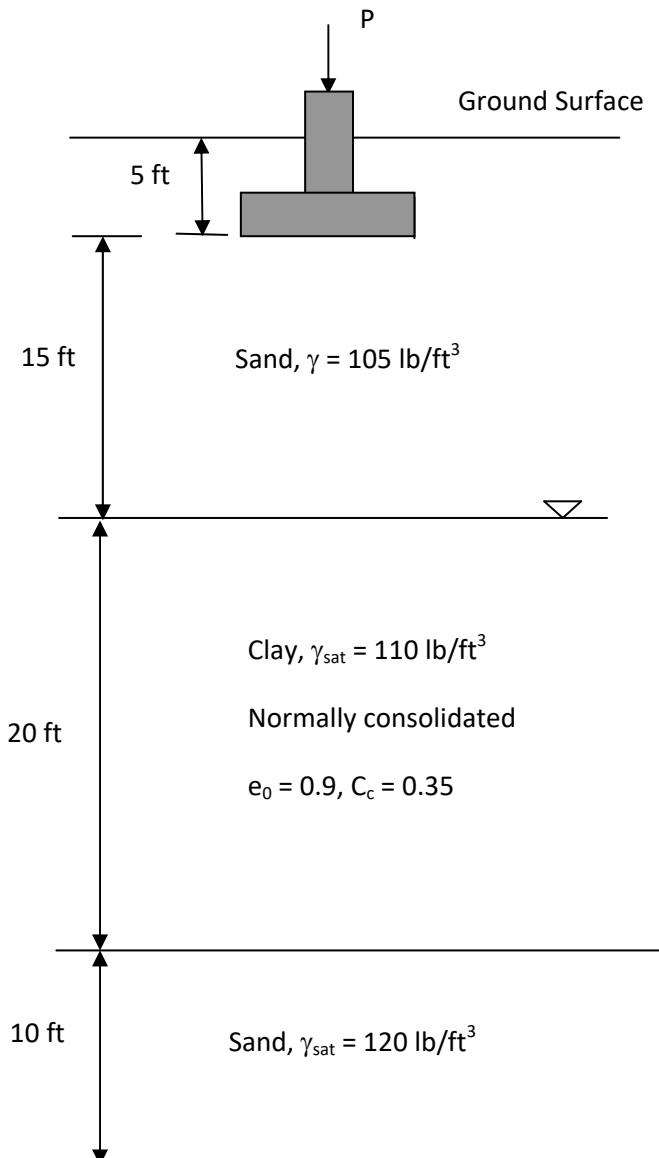

- (A) 5.0 in
- (B) 5.1 in
- (C) 5.2 in
- (D) 5.3 in

## SOLUTIONS:

### Solution: #1

The initial effective stress at the middle of the clay layer is:

$$\sigma'_0 = (7)(121) + (3)(112 - 62.4) = 995.8 \text{ lb/ft}^2$$

Because  $\sigma'_0 < \sigma'_c = 1500 \text{ lb/ft}^2$ , so the soil is overconsolidated clay (OC clay)

The effective stress at the end of consolidation is:

$$\sigma'_0 + \Delta\sigma' = 995.8 + 800 = 1795.8 \text{ lb/ft}^2$$

For OC clay and  $\sigma'_0 + \Delta\sigma' > \sigma'_c$

$$\begin{aligned} S_c &= \frac{C_s H}{1+e_0} \log\left(\frac{\sigma'_c}{\sigma'_0}\right) + \frac{C_c H}{1+e_0} \log\left(\frac{\sigma'_0 + \Delta\sigma'}{\sigma'_c}\right) \\ &= \frac{(0.06)(6)}{1+1} \log\left(\frac{1500}{995.8}\right) + \frac{(0.3)(6)}{1+1} \log\left(\frac{1795.8}{1500}\right) \\ &= 0.102 \text{ ft} = 1.2 \text{ in} \end{aligned}$$

The answer is (C)

### Solution: #2

The initial effective stress at the middle of the clay layer is:

$$\sigma'_0 = (7)(121) + (3)(112 - 62.4) = 995.8 \text{ lb/ft}^2$$

$$\Delta\sigma' = 400 \text{ lb/ft}^2$$

For NC clay

$$\begin{aligned} S_c &= \frac{C_c H}{1+e_0} \log\left(\frac{\sigma'_0 + \Delta\sigma'}{\sigma'_0}\right) \\ &= \frac{(0.35)(6)}{1+0.8} \log\left(\frac{995.8 + 600}{995.8}\right) \\ &= 0.24 \text{ ft} = 2.87 \text{ in} \end{aligned}$$

The answer is (B)

### Solution: #3

The initial effective stress at the middle of the clay layer is:

$$\sigma'_0 = (105)(20) + (110 - 62.4)(10) = 2576 \text{ lb/ft}^2$$

$$\Delta\sigma' = 800 \text{ lb/ft}^2$$

For NC clay

$$\begin{aligned} S_c &= \frac{C_c H}{1 + e_0} \log \left( \frac{\sigma'_0 + \Delta\sigma'}{\sigma'_0} \right) \\ &= \frac{(0.35)(20)}{1 + 0.9} \log \left( \frac{2576 + 800}{2576} \right) \\ &= 0.43 \text{ ft} = 5.2 \text{ in} \end{aligned}$$

The answer is (C)





## Dr. Vagelis Plevris

BSc(Eng), MSc, MBA, PhD, P.E., C.Eng, M.ASCE

Associate Professor

Department of Civil Engineering and Energy Technology

Oslo and Akershus University College of Applied Sciences (HiOA)

Oslo, Norway

Email: [vagelis.plevris@hioa.no](mailto:vagelis.plevris@hioa.no)

---

August 28, 2017

## Career Highlights

1. *Neurocomputing Strategies for Solving Reliability-Robust Design Optimization Problems*  
Winner of the prestigious *Emerald Literati Network Award* – 2011.
2. Developer of a Popular Finite Element Structural Analysis software package, currently being used by scores of Universities and thousands of Engineering students & practicing Engineers worldwide.
3. Principal Investigator (PI) in two Research Grants totalling €400,000.
4. Research Associate (Co-PI) in 5 Research Projects with a total budget of €900,000.
5. Editor of 6 Books:
  - Performance-based Seismic Design of Concrete Structures and Infrastructures
  - *Computational Methods in Earthquake Engineering, Vol. 3* (Springer, 2017).
  - *Seismic Assessment and Rehabilitation of Historic Structures* (IGI Global, 2015).
  - *Computational Methods in Earthquake Engineering, Vol. 2* (Springer, 2013).
  - *Design Optimization of Active and Passive Structural Control Systems* (IGI Global, 2012).
  - *Structural Seismic Design Optimization and Earthquake Engineering: Formulations and Applications* (IGI Global, 2012).
6. Active in Research; Published 17 Papers in International Refereed Journals, 33 Papers in Peer-reviewed International Conference Proceedings and 6 Book Chapters.
7. Editor of 4 International Conference Proceedings volumes.
8. Scholarly Article Reviewer of 40 International Scientific Journals.
9. Associate Editor of 3 International Journals: *Frontiers in Built Environment*, *J. of Computer Science*, *Oriental J. of Computer Science and Technology*
10. Member of the Editorial Board of 16 International Journals and 3 International Conferences.
11. Co-organizer of four International Conferences.
12. 562 citations: “Google Scholar”, with Author *h-index*=11.
13. 12 years of university teaching experience, at both Bachelor’s and Master’s levels.
14. Invited Lecturer in Scientific Workshops, 6 lectures in several European countries.
15. Organizer of 8 Special Sessions in various International Conferences.
16. Working with and mentoring for the elementary and middle school students on STEM topics in rural area public schools.
17. Amateur astronomer, avid star gazer, loves to travel and learn about different cultures & people. Speaks five languages: English, German, Italian, Norwegian and Greek.

### Books By V. Plevris

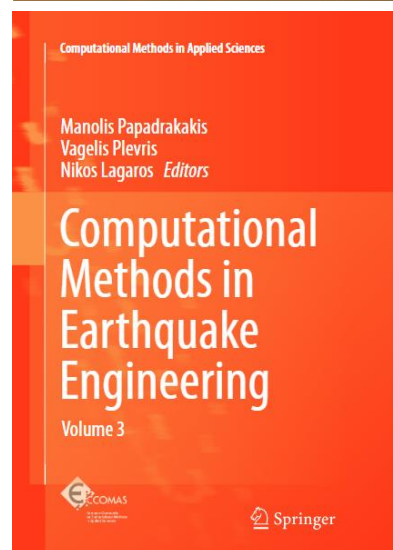
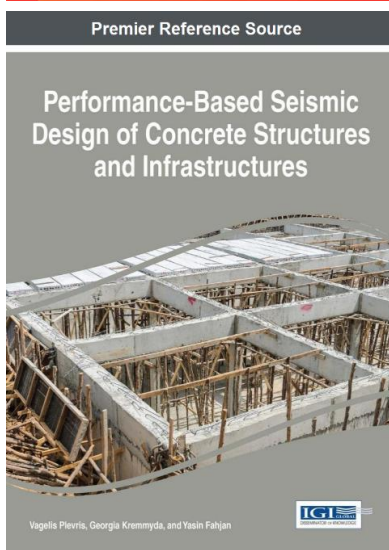
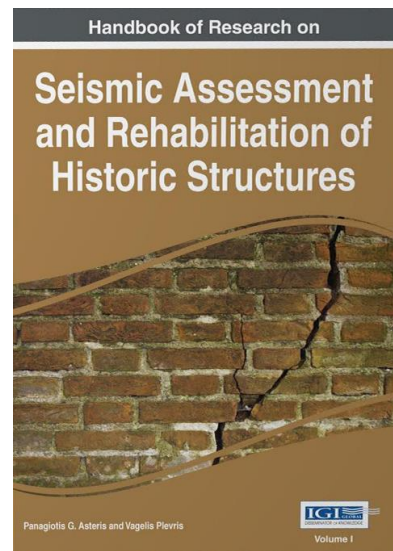
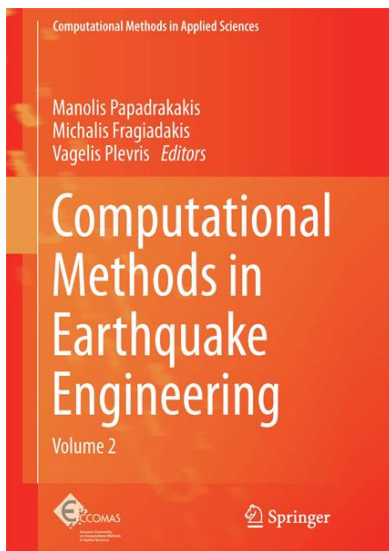
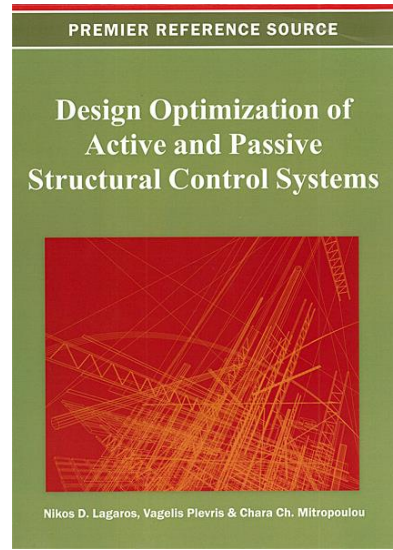
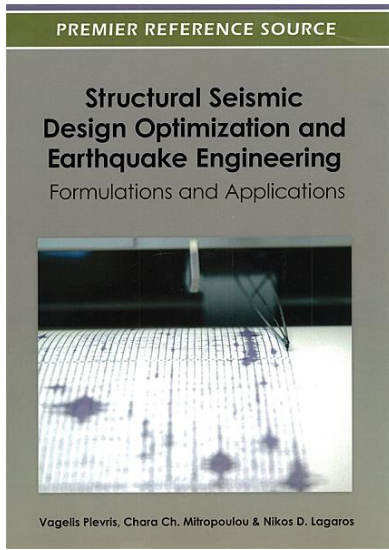

**FUNDAMENTALS OF ENGINEERING**  
**STRENGTH OF MATERIALS**  
**AXIALLY LOADED MEMBERS**

**Problem:** (Axial stress)

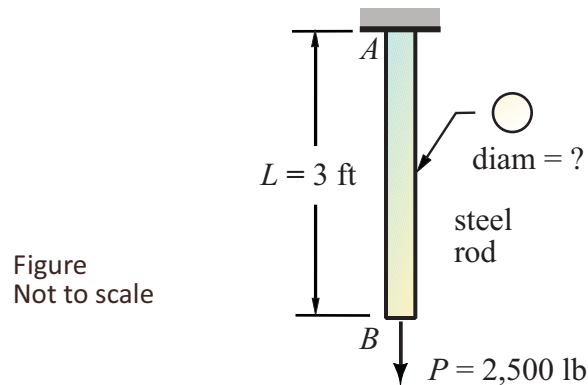

$$E = 29 \times 10^6 \text{ psi}$$

A 3-ft long circular steel rod is subjected to a tensile force of 2,500 lb as shown in the figure. Knowing that the total elongation of the rod is measured as 0.02 inches, answer the following question:

(1) the diameter (inches) of the rod is most nearly

- (A) 0.18
- (B) 0.20
- (C) 0.44
- (D) 0.75

$$d = ?$$

(2) the max. axial stress (psi) in the rod is most nearly

- (A) 8,800
- (B) 12,300
- (C) 16,100
- (D) 19,700

$$\sigma_{\max} = ?$$

**FUNDAMENTALS OF ENGINEERING**  
**STRENGTH OF MATERIALS**  
**AXIALLY LOADED MEMBERS**

**Problem:** **AXIAL-40** **Solution in MS Excel**

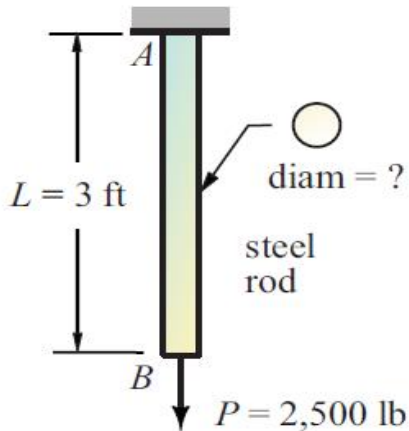

$E =$	2.90E+07	psi
$P =$	2500	lb
$L =$	3	ft
$\Delta L =$	0.02	in

$L = 36 \text{ in}$

$$\sigma = \varepsilon \cdot E = \frac{\Delta L}{L} E \Rightarrow \frac{P}{A} = \frac{\Delta L}{L} E \Rightarrow A = \frac{P \cdot L}{E \cdot \Delta L}$$

$A = 0.1552 \text{ in}^2$

$$A = \pi \cdot \frac{d^2}{4} \Rightarrow d = 2 \sqrt{\frac{A}{\pi}}$$

$d = 0.44 \text{ in}$  (C) Answer

$\sigma = 16111.1 \text{ psi}$  (C) Answer

$$\sigma = \frac{P}{A}$$

## MANNING'S EQUATION

The Manning's Equation is an empirical formula estimating the average velocity of water in a conduit that does not completely enclose the liquid like open channel flow. All flow in open channels is driven by gravity.

*NCEES Reference Handbook, Version 9.4, page-167:*

$$Q = \frac{K}{n} A R_H^{2/3} S^{1/2}$$

Manning's Equation

$$Q = \frac{1}{n} A R_H^{2/3} S^{1/2}$$

SI units ( $K = 1$ )

$$Q = \frac{1.486}{n} A R_H^{2/3} S^{1/2}$$

USCS units ( $K = 1.486$ )

$$R_H = \frac{A}{P}$$

$$V = \frac{Q}{A}$$

$Q$  = Flow rate, quantity of flow, discharge ( ft<sup>3</sup>/sec or m<sup>3</sup>/sec)

$K$  = values are listed above

$A$  = cross-sectional area of flow ( ft<sup>2</sup> or m<sup>2</sup>)

$R_H$  = hydraulic radius (  $R_H = A/P$ ), (feet or meters)

$P$  = wetted perimeter ( feet or meters)

$S$  = gradient, slope of hydraulic surface ( ft/ft or m/m)

$n$  = Manning's roughness coefficient, roughness factor

$V$  = Flow velocity (f/sec or m/sec)

## GEOMETRIC ELEMENTS OF CHANNEL SECTIONS OPEN CHANNEL FLOW

### Rectangular Channel

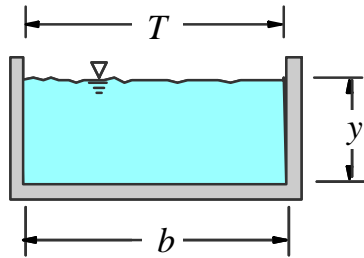

Area

$$A = b \cdot y$$

Wetted Perimeter

$$P = b + 2 \cdot y$$

Top Width

$$T = b$$

### Trapezoidal Channel

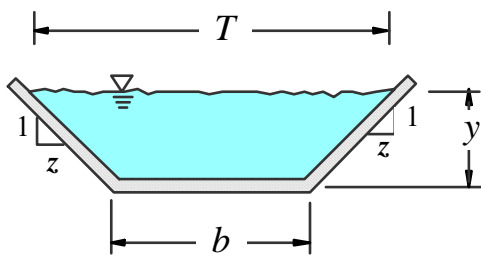

Area

$$A = (b + z y) y$$

Wetted Perimeter

$$P = b + 2 y (1 + z^2)^{1/2}$$

Top Width

$$T = b + 2 z y$$

### Triangular Channel

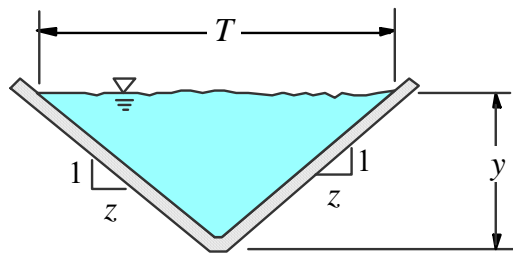

Area

$$A = z y^2$$

Wetted Perimeter

$$P = 2 y (1 + z^2)^{1/2}$$

Top Width

$$T = 2 z y$$

Hydraulic Radius

$$R_H = \frac{A}{P}$$

# FUNDAMENTALS OF ENGINEERING & PROFESSIONAL ENGINEERING

## WATER RESOURCES

### OPEN CHANNEL FLOW / MANNING'S EQUATION

#### Problem: (Open channel flow)

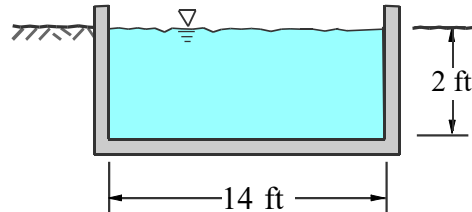

FE / PE  
EXAM

Gradient (slope) of the channel = 2.5 %  
Manning's roughness coeff. ( $n = 0.013$ )

A rectangular concrete channel has a bottom width of 14 ft and water depth of 2.0 ft as shown in the figure. Knowing that the channel is on a 2.5 % slope (gradient) answer the following:

(1) The hydraulic radius (ft) of the channel is most nearly:

- (A) 1.56
- (B) 1.25
- (C) 1.00
- (D) 0.75

$$R_H = ?$$

(2) The discharge ( $\text{ft}^3/\text{sec}$ ) is most nearly:

- (A) 375
- (B) 486
- (C) 557
- (D) 680

$$Q = ?$$

(3) The flow velocity ( $\text{ft}/\text{sec}$ ) is most nearly:

- (A) 13.7
- (B) 18.8
- (C) 24.3
- (D) 34.6

$$V = ?$$



COMPLETE  
SOLUTION

**FUNDAMENTALS OF ENGINEERING & PROFESSIONAL ENGINEERING**  
**WATER RESOURCES**  
**OPEN CHANNEL FLOW / MANNING'S EQUATION**

**Problem:**                      **HYDR-224**                      **Solution in MS Excel**

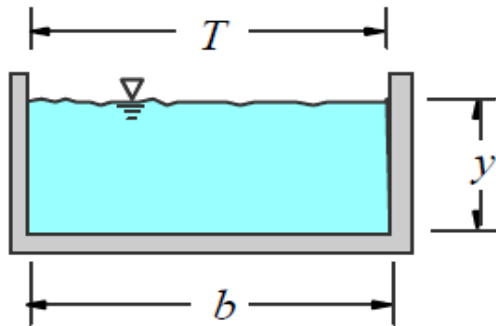

$S =$	2.5%	
$n =$	0.013	
$b =$	14	ft
$y =$	2	ft

$A = 28 \text{ ft}^2$

(Area)  $A = b \cdot y$

$Per = 18 \text{ ft}$

(Perimeter)  $P = b + 2y$

$R_H = 1.56 \text{ ft}$   
(A) Answer

$$R_H = \frac{\text{Area}}{\text{Perimeter}}$$

$$Q = \frac{1.486}{n} A \cdot R_H^{2/3} \cdot S^{1/2}$$

USCS Units  
(K=1.486)

$Q = 679.40 \text{ ft}^3/\text{sec}$   
(D) Answer

$V = 24.3 \text{ ft/sec}$   
(C) Answer

$$V = \frac{Q}{A}$$



# FUNDAMENTALS OF ENGINEERING & PROFESSIONAL ENGINEERING

## WATER RESOURCES

### OPEN CHANNEL FLOW / MANNING'S EQUATION

#### Problem:

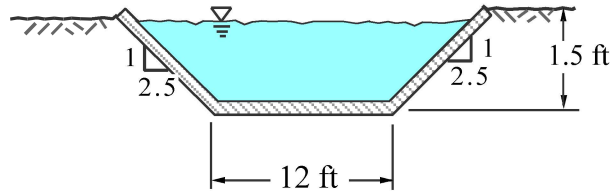

FE/PE  
EXAM

Side slopes of trapezoid 2.5:1 (as shown)

Gradient (slope) of the channel = 2.5 %

Manning's roughness coefficient: ( $n = 0.013$ )

A concrete trapezoidal channel has a bottom width of 12 ft as shown in the figure. Knowing that the channel is on a 2.5 % slope and is flowing at a depth of 1.5 ft throughout its length, answer the following questions:

(1) The hydraulic radius (ft) of the channel is most nearly:

- (A) 1.05
- (B) 1.18
- (C) 1.47
- (D) 2.15

$$R_H = ?$$

(2) The quantity of flow (discharge) ( $\text{ft}^3/\text{sec}$ ) is most nearly:

- (A) 387
- (B) 476
- (C) 510
- (D) 620

$$Q = ?$$

(3) The flow velocity ( $\text{ft}/\text{sec}$ ) is most nearly:

- (A) 30
- (B) 26
- (C) 20
- (D) 18

$$V = ?$$

SOLUTION: (HYDR-232)

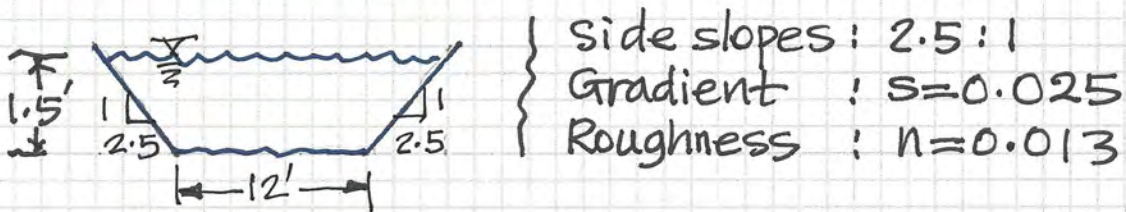

Cross-sectional area: (A)

$$A = (b + zy)y = (12 + 2.5 \times 1.5)1.5 = 23.625 \text{ ft}^2 \checkmark$$

Wetted perimeter: (P)

$$P = b + 2y(1 + z^2)^{1/2} = 12 + 2(1.5)(1 + 2.5^2)^{1/2} = 20.08 \text{ ft}$$

$$P = 20.08 \text{ ft} \checkmark$$

Hydraulic Radius: (R<sub>H</sub>)

$$R_H = A/P = 23.625/20.08 = 1.18 \text{ ft}$$

$$R_H = 1.18 \text{ ft} \checkmark$$

Quantity of flow (discharge): (Q)

$$Q = \frac{1.486}{n} A R^{2/3} s^{1/2}$$

$$= \frac{1.486}{0.013} (23.625)(1.18)^{2/3} (0.025)^{1/2}$$

$$Q = 476 \text{ ft}^3/\text{sec} \checkmark$$

Flow velocity: (V)

$$V = Q/A = 476/23.625 = 20.1 \text{ ft/sec}$$

$$V = 20.1 \text{ ft/sec} \checkmark$$

**FUNDAMENTALS OF ENGINEERING & PROFESSIONAL ENGINEERING**  
**WATER RESOURCES**  
**OPEN CHANNEL FLOW / MANNING'S EQUATION**

**Problem:**                      **HYDR-232**      **Solution in MS Excel**

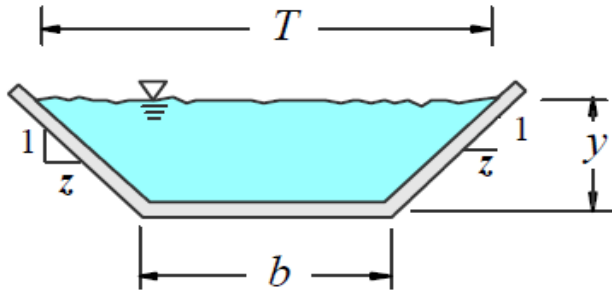

$S = 2.5\%$   
 $n = 0.013$   
 $b = 12$  ft  
 $y = 1.5$  ft  
 Side slopes  $z = 2.5$  :1

$$P = b + 2y(1 + z^2)^{1/2}$$

$P = 20.08$  ft (Wetted Perimeter)

Area = 23.63 ft<sup>2</sup>

$$A = (b + zy) \cdot y$$

$R_H = 1.18$  ft  
 (B) Answer

$$R_H = \frac{\text{Area}}{\text{Perimeter}}$$

$$Q = \frac{1.486}{n} A \cdot R_H^{2/3} \cdot S^{1/2}$$

USCS Units  
 (K=1.486)

$Q = 475.91$  ft<sup>3</sup>/sec  
 (B) Answer

$V = 20.1$  ft/sec  
 (C) Answer

$$V = \frac{Q}{A}$$

# PROFESSIONAL ENGINEERING (P.E.)

## WATER RESOURCES

### OPEN CHANNEL FLOW / MANNING'S EQUATION

#### Problem:

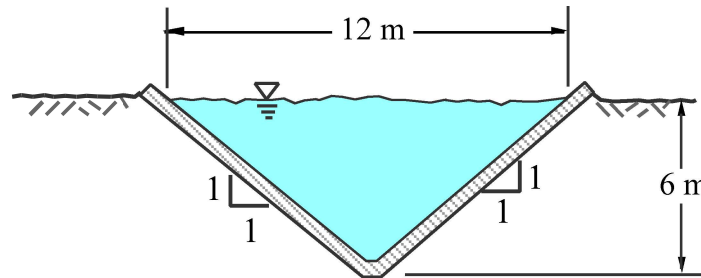

FE/PE  
EXAM  
WATER  
RESOURCES

Side slopes of triangle 1:1 (as shown)

Gradient (slope) of the channel = 2.5 %

Manning's roughness coefficient: ( $n = 0.013$ )

A concrete triangular channel is shown in the figure. Knowing that the channel is on a 2.5 % slope and is flowing at a depth of 6.0 m throughout its length, answer the following questions:

(1) The hydraulic radius (m) of the channel is most nearly:

- (A) 1.05
- (B) 1.18
- (C) 1.47
- (D) 2.12

$$R_H = ?$$

(2) The quantity of flow (discharge) ( $\text{m}^3/\text{sec}$ ) is most nearly:

- (A) 387
- (B) 526
- (C) 610
- (D) 723

$$Q = ?$$

(3) The flow velocity (m/sec) is most nearly:

- (A) 30
- (B) 26
- (C) 20
- (D) 18

$$V = ?$$



COMPLETE  
SOLUTION

A.Z.

**FUNDAMENTALS OF ENGINEERING & PROFESSIONAL ENGINEERING**  
**WATER RESOURCES**  
**OPEN CHANNEL FLOW / MANNING'S EQUATION**

**Problem:** **HYDR-420** **Solution in MS Excel**

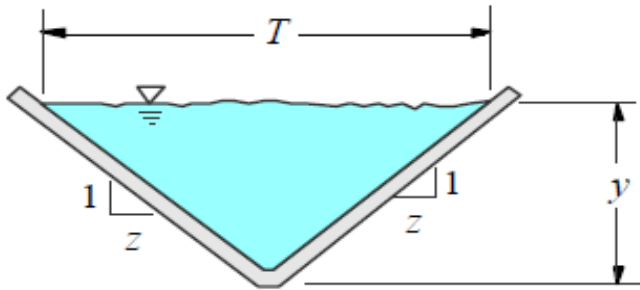

$S = 2.5\%$   
 $n = 0.013$   
 $y = 6$  m  
 Side slopes  $z = 1$  :1

$$P = 2y(1 + z^2)^{1/2}$$

$P = 16.97$  m

(Wetted Perimeter)

Area = 36.00 m<sup>2</sup>

$$A = z \cdot y^2$$

$R_H = 2.12$  m  
 (D) Answer

$$R_H = \frac{\text{Area}}{\text{Perimeter}}$$

$$Q = \frac{1}{n} A \cdot R_H^{2/3} \cdot S^{1/2}$$

SI Units  
 (K=1)

$Q = 722.88$  ft<sup>3</sup>/sec  
 (D) Answer

$V = 20.1$  ft/sec  
 (C) Answer

$$V = \frac{Q}{A}$$

## GRAVITY RETAINING WALLS

FUNDAMENTALS OF ENGINEERING (F.E.)  
PROFESSIONAL ENGINEERING (P.E.)

**Problem:**

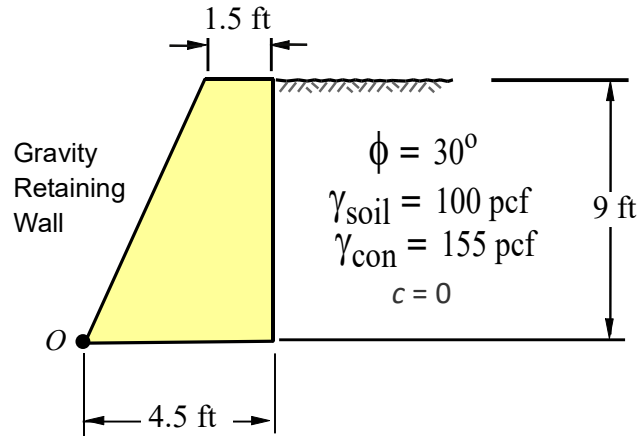

FE/PE  
EXAMS  
REINFORCED  
CONCRETE  
DESIGN

The dimensions of a masonry retaining wall is given as shown. Knowing that *Rankine active earth pressure* will be used in the computations and the wall friction will be disregarded, answer the following:

(1) The *overturning moment* (ft.kip/ft) about the toe at  $O$  is most nearly:

- (A) 4.05
- (B) 5.25
- (C) 6.32
- (D) 7.25

$$M_{ot} = ?$$

(2) The *stabilizing moment* (ft.kip/ft) about the toe at  $O$  is most nearly:

- (A) 16.44
- (B) 15.49
- (C) 12.03
- (D) 11.75

$$M_{stab} = ?$$

(3) The *factor of safety* against overturning about the toe at  $O$  is most nearly:

- (A) 1.90
- (B) 2.20
- (C) 2.97
- (D) 3.25

$$F.S. = ?$$

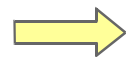

COMPLETE  
SOLUTION

A.Z.

SOLUTION: (GRW-266)

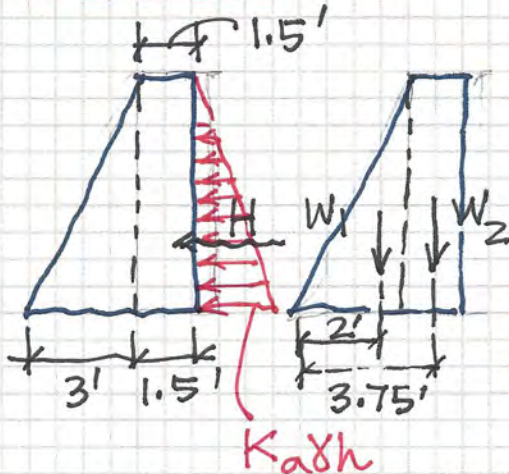

$K_a$ : Rankine active soil pressure coefficient

$$K_a = \frac{1 - \sin \phi}{1 + \sin \phi} = \frac{1 - \sin 30^\circ}{1 + \sin 30^\circ} = \frac{1}{3}$$

$H$  = Total lateral force

$$H = \frac{1}{2} K_a \gamma_{\text{soil}} \cdot h^2 = \frac{1}{2} \left(\frac{1}{3}\right) (100) (9^2) = \underline{1350 \text{ lb}}$$

Overturning moment: ( $M_{OT}$ )

$$M_{OT} = H \left(\frac{h}{3}\right) = 1350 \left(\frac{9}{3}\right) = \underline{4050 \text{ ft}\cdot\text{lb}}$$

Vertical loads: ( $W_i$ )

$$W_1 = \frac{1}{2} (3) (9') (155) (1) = 2092 \text{ lb}$$

$$W_2 = (1.5) (9') (155) (1) = 2092 \text{ lb}$$

Stabilizing moment: ( $M_S$ )

$$M_S = W_1 (2') + W_2 (3.75') = (2092)(2') + (2092)(3.75')$$

$$M_S = \underline{12,029 \text{ ft}\cdot\text{lb}}$$

Factor of safety against overturning

$$F.S. = \frac{M_S}{M_{OT}} = \frac{12,029}{4050} = \underline{2.97}$$

Dr. Z

ANSWERS

$$M_{OT} = 4050 \text{ ft}\cdot\text{lb}$$

$$M_S = 12,029 \text{ ft}\cdot\text{lb}$$

$$F.S. = 2.97$$

**FUNDAMENTALS OF ENGINEERING  
PROFESSIONAL ENGINEERING**

**STRUCTURAL ANALYSIS  
DETERMINATE FRAMES**

**Problem:**

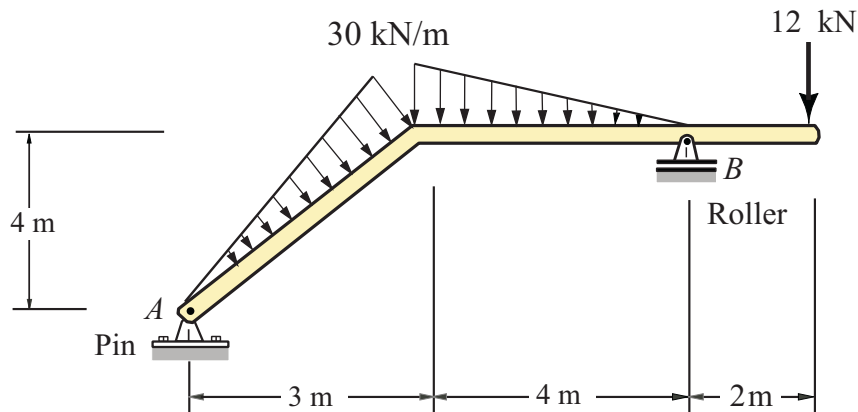

FE/PE  
EXAM  
STRUCTURES

Support A : Hinge  
Support B : Roller

A determinate frame is loaded as shown in the figure. Knowing that support A is a pin and support B is a roller, answer the following questions:

(1) The magnitude of the horizontal support reaction (kN) at A

- (A) 60.0
- (B) 54.2
- (C) 34.5
- (D) 20.0

$$A_x = ?$$

(2) The magnitude of the vertical support reaction (kN) at B

- (A) 65.1
- (B) 78.4
- (C) 88.3
- (D) 92.7

$$B_y = ?$$

(3) The magnitude of the vertical support reaction (kN) at A

- (A) 18.5
- (B) 28.7
- (C) 35.8
- (D) 46.9

$$A_y = ?$$

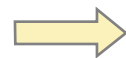

COMPLETE  
SOLUTION

A.Z.



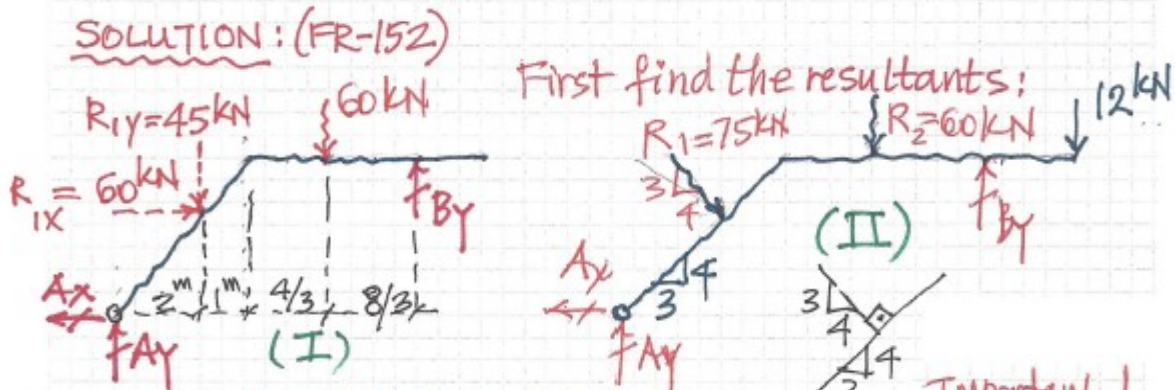

$$\left\{ \begin{aligned} R_1 &= \frac{1}{2} (5\text{m}) (30) = 75 \text{ kN} \\ R_2 &= \frac{1}{2} (4\text{m}) (30) = 60 \text{ kN} \end{aligned} \right.$$

Important!  
When two lines are  $\perp$  slopes will be as shown.

Horizontal equilibrium equation:

$$\leftarrow \sum F_x = 0 \quad A_x - 60 \text{ kN} = 0 \rightarrow \quad \boxed{A_x = 60 \text{ kN}} \leftarrow$$

Taking moment about point (A)

$\sum M_A = 0$  (using fig. II would be better)

$$(75 \text{ kN}) \left( \frac{2}{3} \times 5 \right) + (60 \text{ kN}) \left( 3 + \frac{4}{3} \right) + (12 \text{ kN}) (9\text{m}) = 7B_y$$

$$7B_y = 250 + 260 + 108$$

$$\boxed{B_y = 88.29 \text{ kN}} \uparrow$$

$$\boxed{B_y = 88.29 \text{ kN}} \uparrow$$

Taking moment about B

$$\curvearrowright \sum M_B = 0$$

$$(-12 \text{ kN})(2\text{m}) + 60 \left( \frac{2}{3} \times 4 \right) + 45(1+4) + 60 \left( \frac{4}{3} \right) - 4A_x - 7A_y = 0$$

$$-24 + 160 + 225 + 80 - 4(60) - 7A_y = 0$$

CHECK

$$\uparrow \sum F_y = 0$$

$$\boxed{A_y = 28.7 \text{ kN}} \uparrow$$

$$A_y + B_y = 45 + 60 + 12 \text{ kN}$$

$$117 \text{ kN} = 117 \text{ kN} \quad \text{O.K.} \checkmark$$

DR. Z

# COMPRESSION MEMBERS

NCEES-Reference Handbook, Page 157

$$P_u \leq \phi P_c$$

$$P_u \leq \phi P_n$$

$$\phi P_c = \phi F_{cr} A_g$$

$$\sqrt{\frac{E}{F_y}} = \sqrt{(29,000/50)} = \sqrt{580} = 28.03$$

$$F_e = \frac{\pi^2 E}{(KL/r)^2}$$

$KL/r_{\min}$  = slenderness ratio

$$\frac{KL}{r} \leq 4.71 \sqrt{\frac{E}{F_y}}$$

$$F_{cr} = 0.658 \left( \frac{F_y}{F_e} \right) F_y$$

$$\frac{KL}{r} > 4.71 \sqrt{\frac{E}{F_y}}$$

$$F_{cr} = 0.877 F_e$$

$K$  = effective length factor (AISC)

$L$  = column length

$KL$  = effective column length

$KL/r$  = slenderness ratio

$r$  = radius of gyration

$F_y$  = yield stress of steel

$F_e$  = Euler stress

$F_{cr}$  = critical stress

$E$  = modulus of elasticity of steel

# DESIGN OF STEEL STRUCTURES

## COMPRESSION MEMBERS

**Problem:** Steel Column (W)

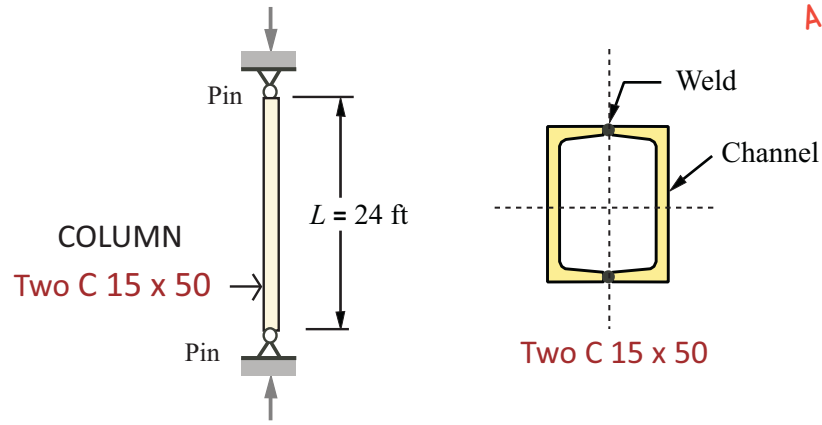

STRUCTURAL  
ANALYSIS

FE/PE  
EXAMS

Two C-Channels are welded together at flanges

Two C 15 x 50 channels are welded together to form a column as shown in the figure. Using the data for the cross section and the column length, answer the following questions:

(1) The min. area moment of inertia ( $\text{in}^4$ ) is most nearly:

- (A) 211.20
- (B) 272.85
- (C) 312.53
- (D) 355.10

$$I_{\min} = ?$$

(2) The minimum radius of gyration (in.) is most nearly:

- (A) 4.60
- (B) 4.08
- (C) 3.60
- (D) 3.05

$$r_{\min} = ?$$

(3) The slenderness ratio of the column is most nearly:

- (A) 98.50
- (B) 94.43
- (C) 85.24
- (D) 82.42

$$KL/r_{\min} = ?$$

## LOAD FACTORS & COMBINATIONS (LRFD)

FUNDAMENTALS OF ENGINEERING (F.E.)

PROFESSIONAL ENGINEERING (P.E.)

$$U = 1.2 D + 1.6 L$$

$D$  = Dead Load

$L$  = Live Load

REINFORCED  
CONCRETE

$ACI$  = American Concrete Institute

$IBC$  = International Building Code

$ASCE$  = American Society of Civil Engineers

$NCEES$  = Ref. Handbook (Page-153), v. 9.4

(1)  $U = 1.4 (D + F)$

(2)  $U = 1.2 (D + F + T) + 1.6 (L + H) + 0.5 (L_r \text{ or } S \text{ or } R)$

(3)  $U = 1.2 D + 1.6 (L_r \text{ or } S \text{ or } R) + (1.0 L \text{ or } 0.8 W)$

(4)  $U = 1.2 D + 1.6 W + 1.0 L + 0.5 (L_r \text{ or } S \text{ or } R)$

(5)  $U = 1.2 D + 1.0 E + 1.0 L + 0.2 S$

(6)  $U = 0.9 D + 1.6 W + 1.6 H$

(7)  $U = 0.9 D + 1.0 E + 1.6 H$

*The max. value  
will be used.*

$NCEES$ , Reference Handbook (Page-153), v. 9.4

$D$  = Dead loads

$L$  = Live loads (floor)

$L_r$  = Live loads (roof)

$E$  = Earthquake loads

$R$  = Rain load

$S$  = Snow load

$W$  = Wind load

**DESIGN OF CONCRETE STRUCTURES**  
FUNDAMENTALS OF ENGINEERING (F.E.)  
PROFESSIONAL ENGINEERING (P.E.)

Problem: (Transformed Section Method)

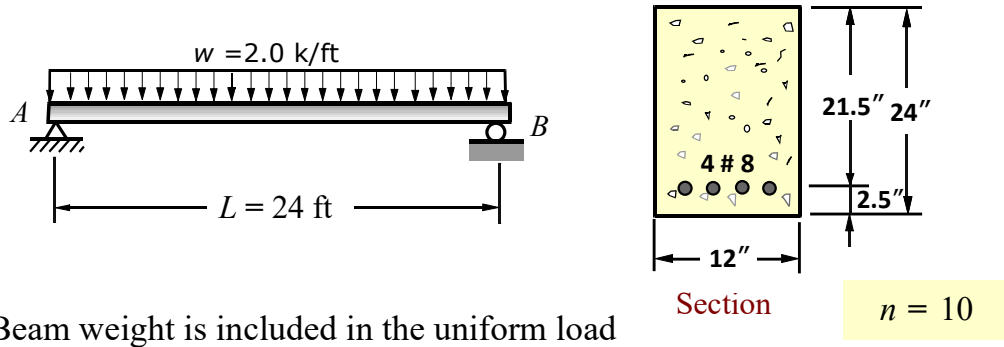

(1) Flexural stress in concrete (psi) is most nearly:

- (A) 1620
- (B) 1730
- (C) 1850
- (D) 1980

$$f_{con} = ?$$

(2) Flexural stress (psi) in steel is most nearly:

- (A) 24,650
- (B) 27,470
- (C) 29,380
- (D) 31,120

$$f_{steel} = ?$$

## FACTORED LOADS / FACTORED MOMENTS

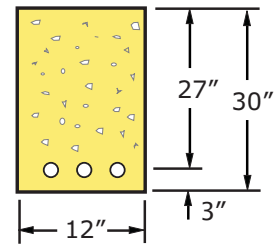
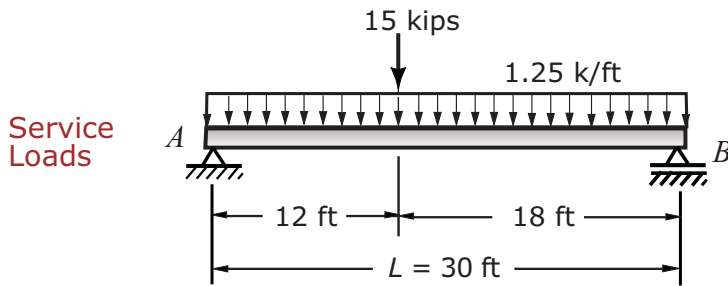

**Section**

**Beam Weight**

$$BM = 375.0 \text{ lb/ft}$$

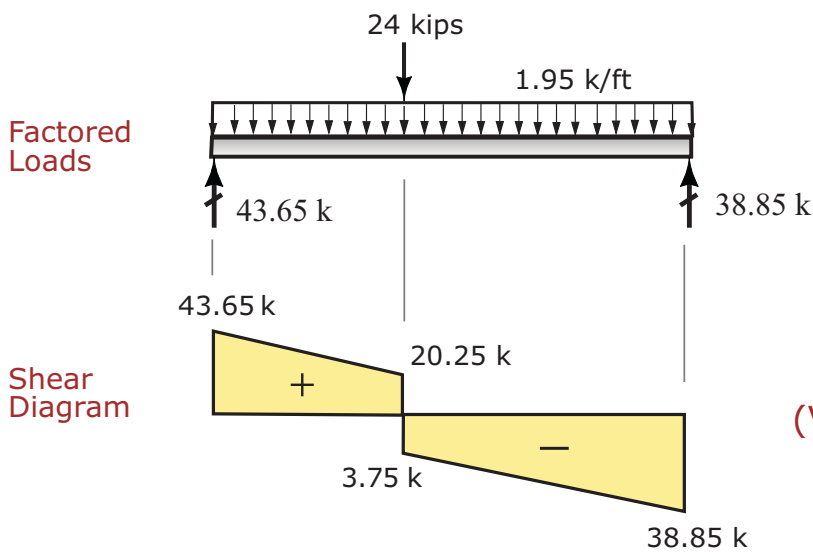

### Beam Weight

$$BM = \frac{(12)(30)}{144} (150) = 375 \text{ lb/ft} = 0.375 \text{ k/ft}$$

### Factored Dead Load

$$w_U = 1.2 (0.375 + 1.25) = 1.2 (1.625) = 1.95 \text{ k/ft}$$

### Factored Live Load

$$w_U = 1.6 (15 \text{ kips}) = 24 \text{ kips}$$

### Maximum Factored Moment

$$M_U = 0.5 (12) (43.65 + 20.25) = 383.4 \text{ ft-kips}$$

$$M_U = 383.4 \text{ ft-kips}$$

## DEFLECTIONS OF DETERMINATE TRUSSES

FUNDAMENTALS OF ENGINEERING (F.E.)

PROFESSIONAL ENGINEERING (P.E.)

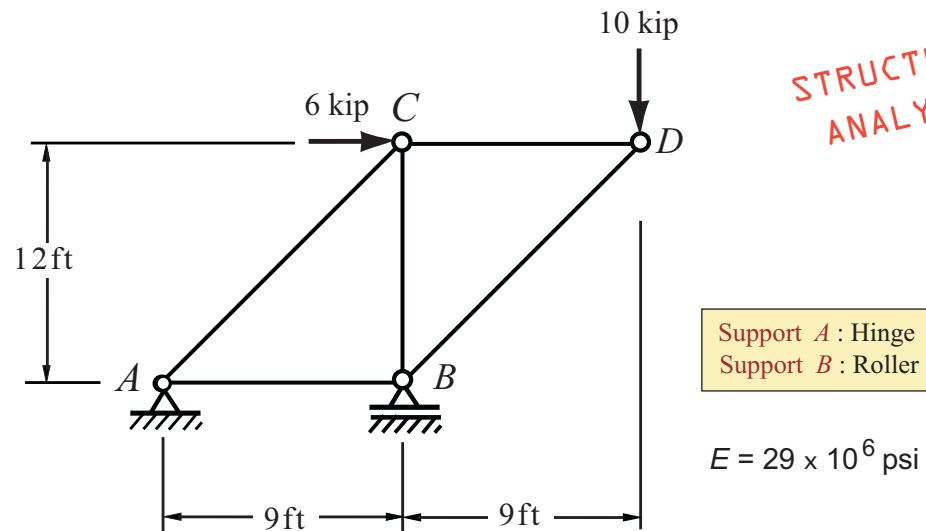

STRUCTURAL  
ANALYSIS

Member	AC	CD	BD	AB	BC
Area (in <sup>2</sup> )	3.00	2.00	2.00	1.50	2.50

A determinate plane truss is given as shown in the figure. Using the listed cross-sectional areas and material constants answer the following questions:

- (1) Determine the vertical deflection of joint  $D$
- (2) Determine the horizontal displacement of joint  $D$

## MEMBER FORCES (SUMMARY)

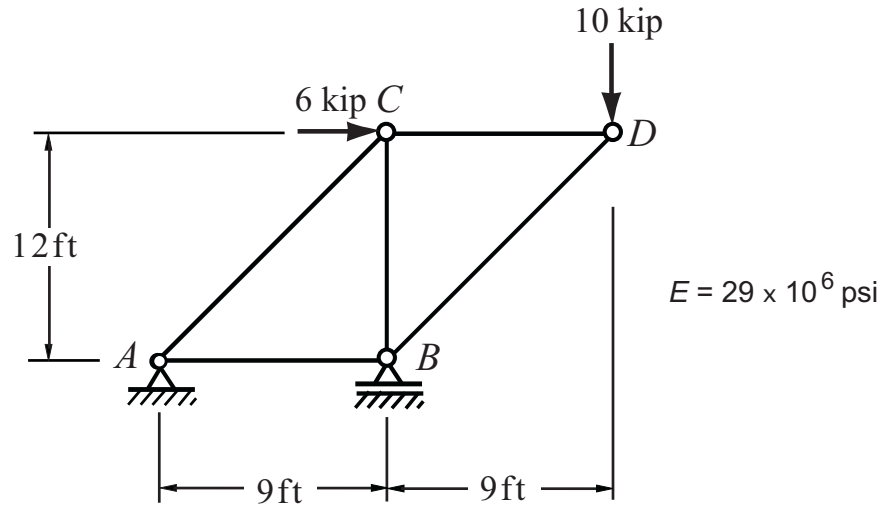

Member Forces for  
Given Loads (F)

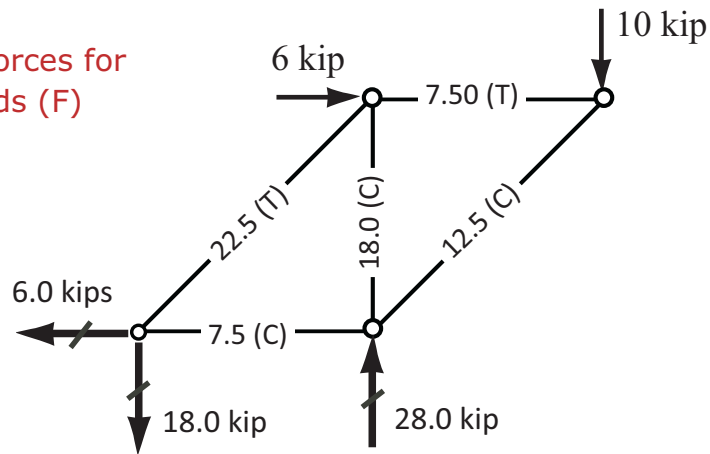

(F)  
Given Load

Member Forces for  
Unit Load (Vertical)

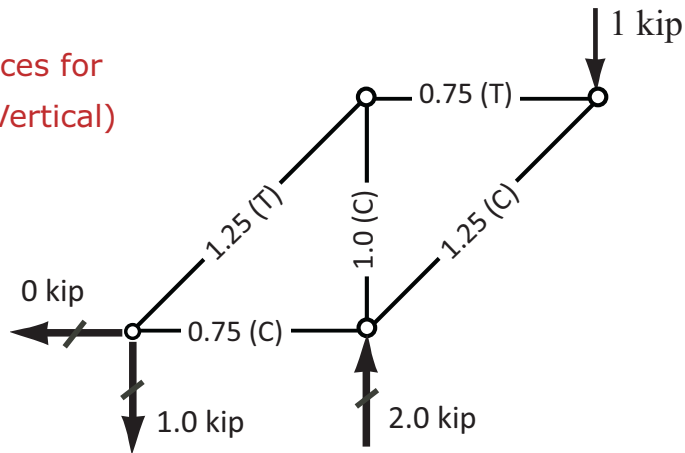

(f)  
Unit Load at D  
For Vertical  
Deflection



## MEMBER FORCES (SUMMARY)

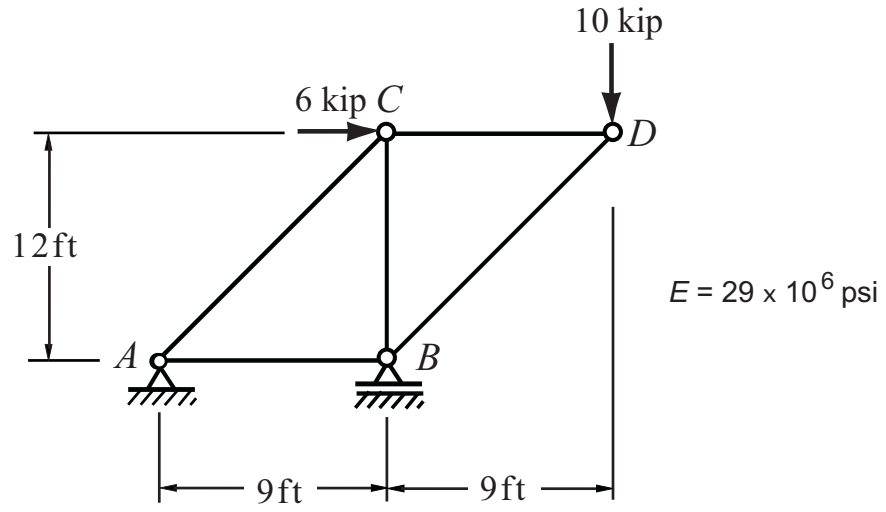

*Member Forces for  
Given Loads (F)*

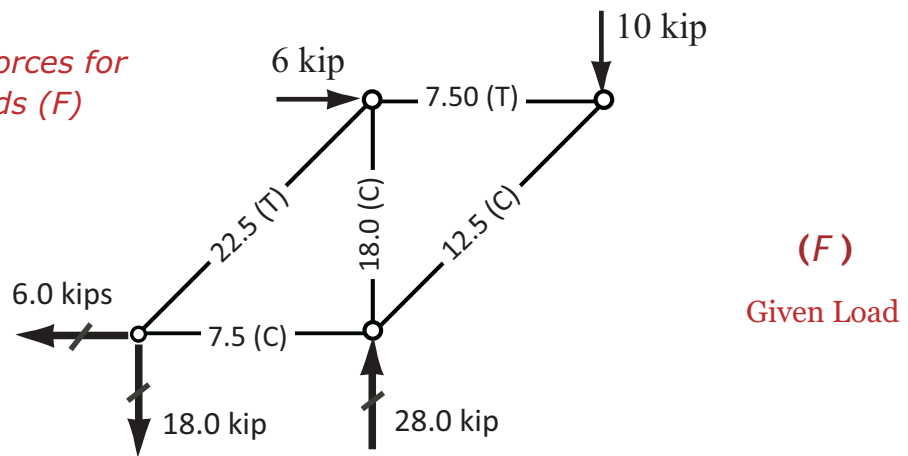

*Member Forces for  
Unit Load (Horiz.)*

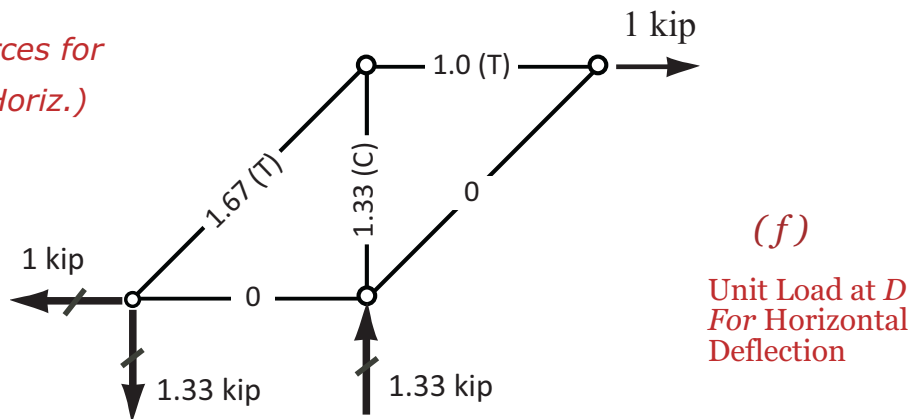

## Deflections of Determinate Trusses

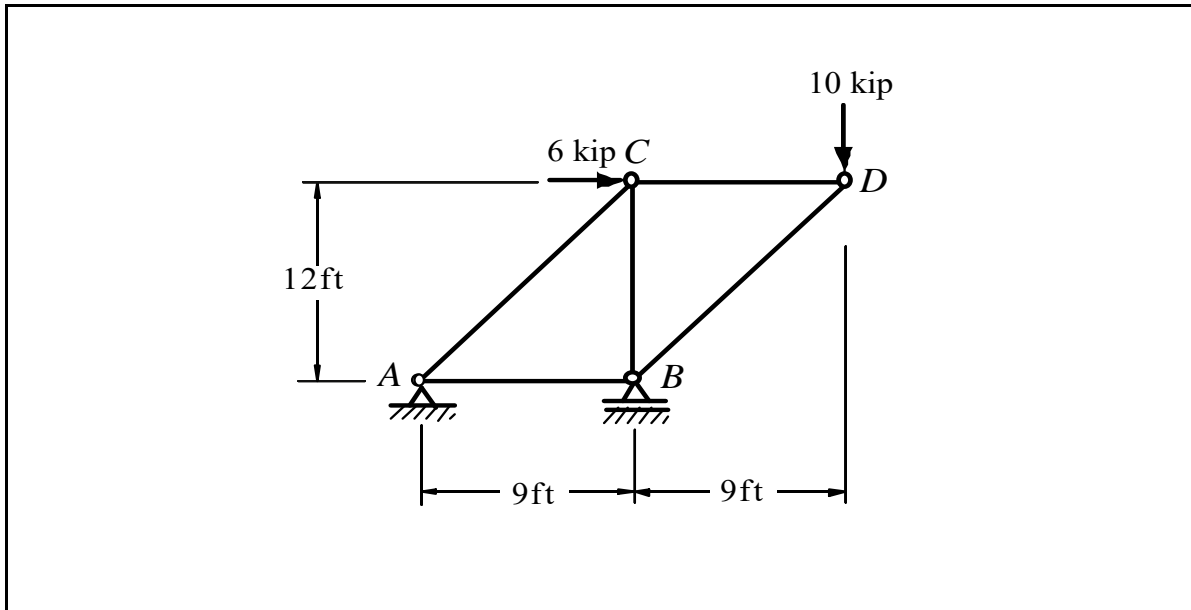

Member	$L$ (ft)	$L$ (in)	$A$ (in <sup>2</sup> )	$L/A$	$F$ (kip)	$f$	$Ff \cdot L/A$
<b>AC</b>	15.00	180.00	3.00	60.00	22.50	1.25	1,688
<b>CD</b>	9.00	108.00	2.00	54.00	7.50	0.75	304
<b>BD</b>	15.00	180.00	2.00	90.00	-12.50	-1.25	1,406
<b>AB</b>	9.00	108.00	1.50	72.00	-7.50	-0.75	405
<b>BC</b>	12.00	144.00	2.50	57.60	-18.00	-1.00	1,037

$$\Sigma = 4,839$$

### Vertical deflection of point $D$

$$\delta_D = \Sigma Ff \cdot L / AE = (4,839) \cdot (1000) / 29,000,000 = 0.1669 \text{ in.} \quad \downarrow$$

## Deflections of Determinate Trusses

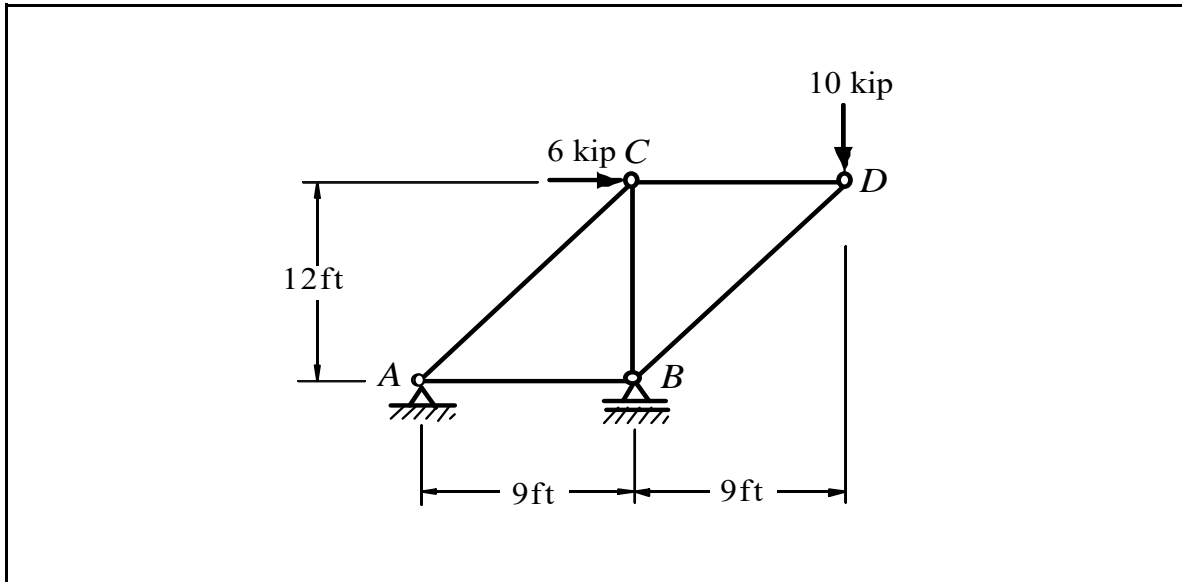

Member	<i>L</i>	<i>L</i>	<i>A</i>	<i>L/A</i>	<i>F</i>	<i>f</i>	<i>Ff.L/A</i>
	(ft)	(in)	(in <sup>2</sup> )		(kip)		
<b>AC</b>	15.00	180.00	3.00	60.00	22.50	1.67	2,255
<b>CD</b>	9.00	108.00	2.00	54.00	7.50	1.00	405
<b>BD</b>	15.00	180.00	2.00	90.00	-12.50	0.00	0
<b>AB</b>	9.00	108.00	1.50	72.00	-7.50	0.00	0
<b>BC</b>	12.00	144.00	2.50	57.60	-18.00	-1.33	1,379

$$\Sigma = 4,038$$

### Horizontal deflection of point *D*

$$\delta_{D_x} = \Sigma Ff.L/AE = (4,038).(1000) / 29,000,000 = 0.1392 \text{ in.} \leftarrow$$

## DETERMINATE BEAMS / SUPPORT REACTIONS

FUNDAMENTALS OF ENGINEERING (F.E.)  
PROFESSIONAL ENGINEERING (P.E.)

### Problem:

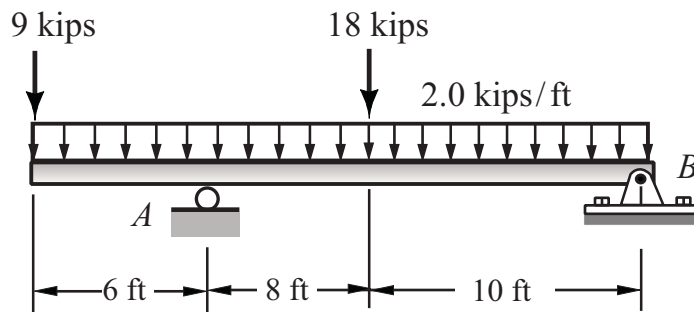

STRUCTURAL  
ANALYSIS

FE/PE  
EXAMS

An overhanging beam is loaded as shown. Using the given dimensions and support conditions, answer the following:

(1) The vertical support reaction (kips) at  $B$  is most nearly:

- (A) 18
- (B) 21
- (C) 27
- (D) 34

$$B_y = ?$$

(2) The vertical support reaction (kips) at  $A$  is most nearly:

- (A) 21
- (B) 31
- (C) 46
- (D) 54

$$A_y = ?$$

(3) The absolute maximum bending moment (ft.kips) in the beam is most nearly:

- (A) 98
- (B) 110
- (C) 135
- (D) 146

$$M_{\max} = ?$$

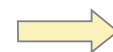

STUDENT'S  
SOLUTION

Solution by Dr. Vagelis Plevris

Model

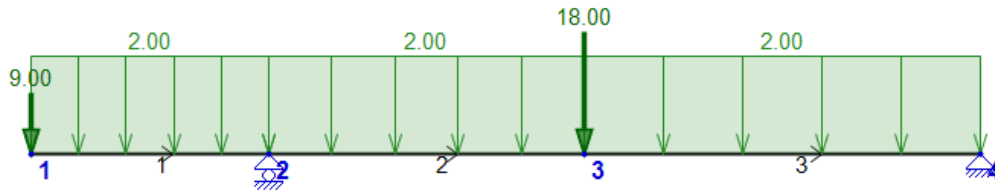

Support Reactions

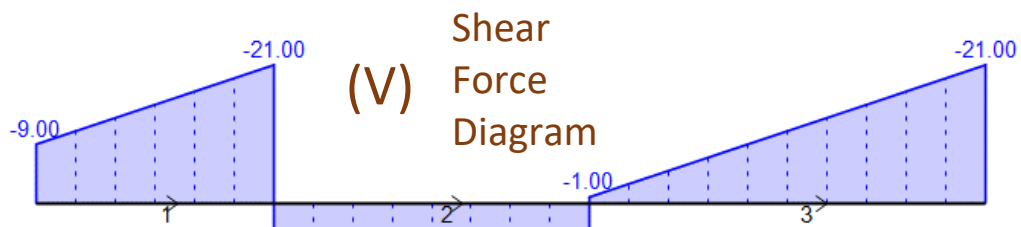
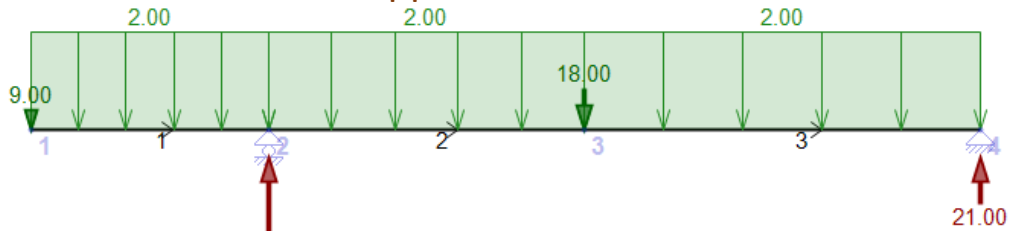

- Answers:**  
(1) B (21)  
(2) D (54)  
(3) B (110)

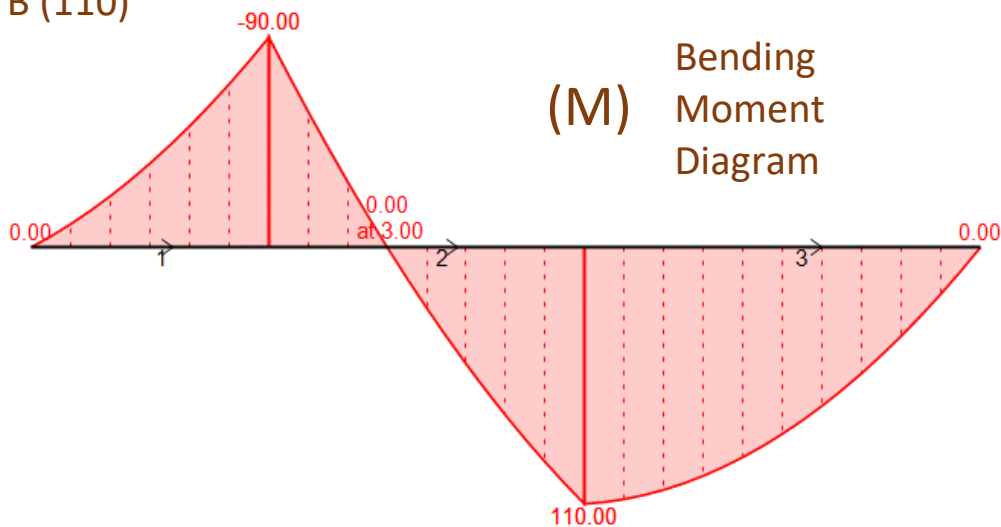

# MATHEMATICS

## VECTORS

### Dot Product of Two Vectors:

$$\mathbf{a} \cdot \mathbf{b} = |\mathbf{a}| \times |\mathbf{b}| \times \cos(\theta)$$

The result of the dot product is a scalar.

$|\mathbf{a}|$  : the magnitude (length) of vector  $\mathbf{a}$

$|\mathbf{b}|$  : the magnitude (length) of vector  $\mathbf{b}$

$\theta$  : the angle between  $\mathbf{a}$  and  $\mathbf{b}$

### Example: (Using Magnitudes / Angle)

$$\mathbf{a} \cdot \mathbf{b} = |\mathbf{a}| \times |\mathbf{b}| \times \cos(\theta)$$

$$\mathbf{a} \cdot \mathbf{b} = 6 \times 10 \times \cos(40^\circ)$$

$$\mathbf{a} \cdot \mathbf{b} = 6 \times 10 \times 0.766$$

$$\mathbf{a} \cdot \mathbf{b} = 45.96 \text{ units}$$

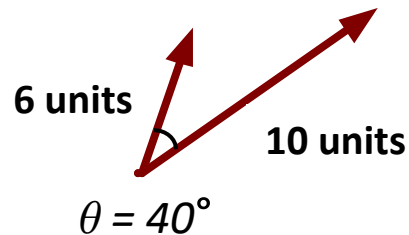

### Example: (Using Components)

$$\mathbf{a} \cdot \mathbf{b} = a_x \times b_x + a_y \times b_y$$

$$\mathbf{a} \cdot \mathbf{b} = -3 \times 5 + 4 \times 12$$

$$\mathbf{a} \cdot \mathbf{b} = -15 + 48$$

$$\mathbf{a} \cdot \mathbf{b} = 33 \text{ units}$$

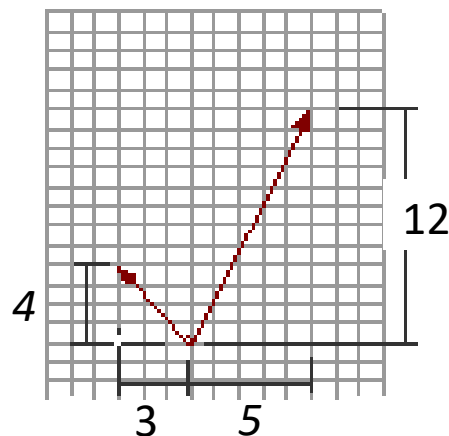

# VECTOR COMPUTATIONS

## CROSS PRODUCT

Problem:

$$\begin{aligned} \mathbf{A} &= a_x \mathbf{i} + a_y \mathbf{j} + a_z \mathbf{k} \\ \mathbf{B} &= b_x \mathbf{i} + b_y \mathbf{j} + b_z \mathbf{k} \end{aligned}$$

NCEES  
REF. HANDBOOK  
PAGE-34

The cross product is a vector product of magnitude  $|\mathbf{B}| \times |\mathbf{A}| \sin \theta$

$|\mathbf{B}| |\mathbf{A}| \sin \theta$  which is perpendicular to the plane containing  $\mathbf{A}$  and  $\mathbf{B}$ . The product is

$$\mathbf{A} \times \mathbf{B} = \begin{vmatrix} \mathbf{i} & \mathbf{j} & \mathbf{k} \\ a_x & a_y & a_z \\ b_x & b_y & b_z \end{vmatrix} = - \mathbf{B} \times \mathbf{A}$$

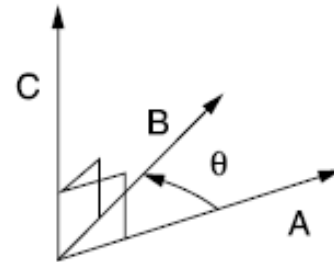

The sense of  $\mathbf{A} \times \mathbf{B}$  is determined by the right-hand rule.

$$\mathbf{A} \times \mathbf{B} = |\mathbf{A}| |\mathbf{B}| \mathbf{n} \sin \theta, \text{ where}$$

$\mathbf{n}$  = unit vector perpendicular to the plane of  $\mathbf{A}$  and  $\mathbf{B}$ .

**FUNDAMENTALS OF ENGINEERING**  
**MATHEMATICS**  
**VECTORS**

FE  
EXAM

**Dot product of two vectors:**

$$(1) \quad \mathbf{a} = \{ -2, 3, 1 \} \quad \mathbf{a} \cdot \mathbf{b} = 17 \\ \mathbf{b} = \{ -1, 4, 3 \}$$

$$(2) \quad \mathbf{a} = \{ 1, 3, 2 \} \quad \mathbf{a} \cdot \mathbf{b} = 8 \\ \mathbf{b} = \{ 4, -2, 5 \}$$

$$(3) \quad \mathbf{a} = \{ -2, 4, 1 \} \quad \mathbf{a} \cdot \mathbf{b} = 1 \\ \mathbf{b} = \{ -3, -2, 3 \}$$

$$(4) \quad \mathbf{a} = \{ -2, 5, 4 \} \quad \mathbf{a} \cdot \mathbf{b} = ? \\ \mathbf{b} = \{ -3, 1, 2 \}$$

$$(5) \quad \mathbf{a} = \{ 3, 4, 2 \} \quad \mathbf{a} \cdot \mathbf{b} = ? \\ \mathbf{b} = \{ 1, 3, -2 \}$$

**Cross product of two vectors:**

$$(1) \quad \mathbf{a} = \{ 2, -3, 1 \} \quad \mathbf{a} \times \mathbf{b} = \{ -17, -7, 13 \} \\ \mathbf{b} = \{ 3, 2, 5 \}$$

$$(2) \quad \mathbf{a} = \{ 1, -2, 5 \} \quad \mathbf{a} \times \mathbf{b} = \{ 4, 17, 6 \} \\ \mathbf{b} = \{ 4, -2, 3 \}$$

$$(3) \quad \mathbf{a} = \{ 2, -4, 7 \} \quad \mathbf{a} \times \mathbf{b} = \{ -25, 33, 26 \} \\ \mathbf{b} = \{ 5, 3, 1 \}$$

$$(4) \quad \mathbf{a} = \{ -2, 3, 1 \} \quad \mathbf{a} \times \mathbf{b} = \{ 18, 14, -6 \} \\ \mathbf{b} = \{ 4, -3, 5 \}$$

$$(5) \quad \mathbf{a} = \{ 2, 3, 4 \} \quad \mathbf{a} \times \mathbf{b} = \{ -18, 8, 3 \} \\ \mathbf{b} = \{ 1, 3, -2 \}$$



**FUNDAMENTALS OF ENGINEERING (F.E.)**

**MATHEMATICS**

**AREAS OF TRIANGLES**

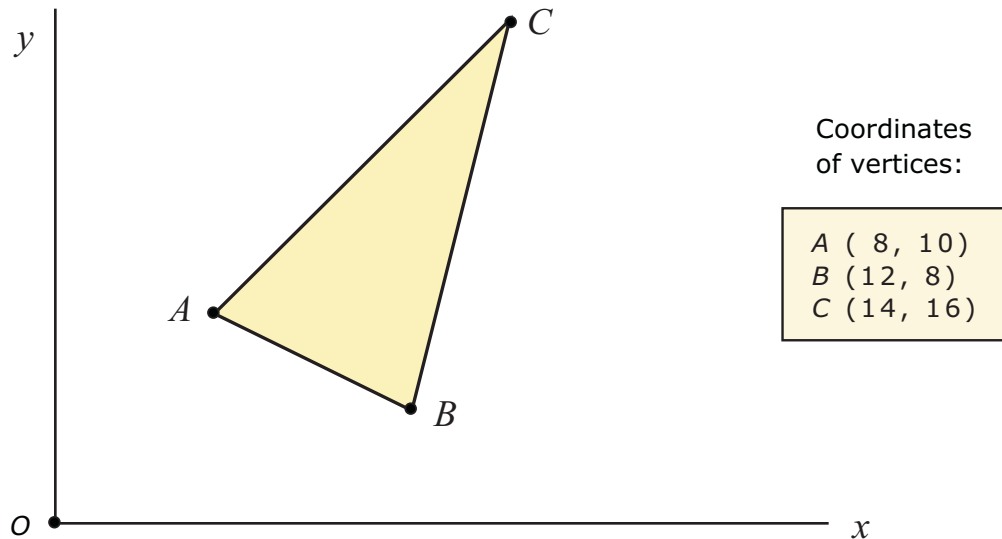

A plane triangle is given as shown in the figure. Using the listed coordinates of the vertices  $A$ ,  $B$ , and  $C$  answer the following:

The area ( unit <sup>2</sup> ) of this triangle is most nearly:

- (A) 12
- (B) 15
- (C) 18
- (D) 38

$A = ?$

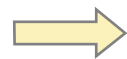

COMPLETE SOLUTION

## APPLICATIONS OF DETERMINANTS

Determinants may also be used in simplifying notation of complex mathematical expressions

**Example:**

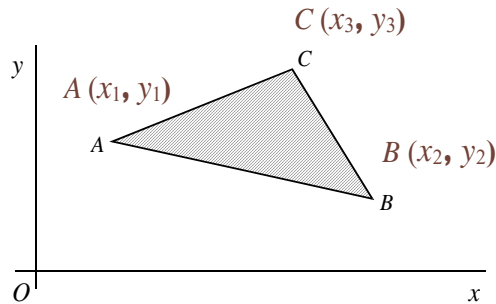

A triangle  $ABC$  is given as shown in the figure. Using the listed coordinates of  $A$ ,  $B$ , and  $C$  determine the area of the triangle.

**Solution:**

Draw the vertical dashed lines from points  $A$ ,  $B$ , and  $C$ .

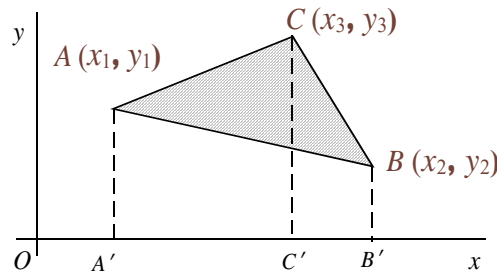

Area of the Trapezoid  $AA'CC' = \left(\frac{x_3 - x_1}{2}\right)(y_1 + y_3)$

Area of the Trapezoid  $BB'CC' = \left(\frac{x_2 - x_3}{2}\right)(y_2 + y_3)$

Area of the Trapezoid  $AA'BB' = \left(\frac{x_2 - x_1}{2}\right)(y_2 + y_1)$

$$\begin{aligned} \text{Area of } ABC &= \text{Area } AA'CC' \\ &+ \text{Area } BB'CC' \\ &- \text{Area } AA'BB' \end{aligned}$$

This will yield a fairly complex relationship for the area. But if we use determinant relationship, the required area may be calculated from the following simple determinant and applying the given data:

$$\text{Area} = \frac{1}{2} \cdot \begin{vmatrix} x_1 & y_1 & 1 \\ x_2 & y_2 & 1 \\ x_3 & y_3 & 1 \end{vmatrix} = \frac{1}{2} \begin{vmatrix} 8 & 10 & 1 \\ 12 & 8 & 1 \\ 14 & 16 & 1 \end{vmatrix} = 36/2 = 18$$

Correct Answer is (C)