



**BALTIMORE  
AIRCOIL COMPANY**



**Series 3000**

# Series 3000 Cooling Tower

**RIGGING & ASSEMBLY INSTRUCTIONS**



**Series 3000 Cooling Towers should be rigged and assembled as outlined in this bulletin.**

These procedures should be thoroughly reviewed prior to the actual rigging and assembly of the equipment to acquaint all personnel with procedures to be followed and to assure that all necessary equipment will be available beforehand.



Be sure to have a copy of the certified drawing available for reference. If you do not have a copy of this drawing, or if you need additional information about this unit, contact your local BAC Representative whose name and telephone number are on a label adjacent to the access door. The model number and serial number of the unit are also located in this area.



# Table of Contents

RIGGING & ASSEMBLY INSTRUCTIONS » SERIES 3000 COOLING TOWER

## 1 Introduction

---

- 2 Safety
- 2 Shipping
- 2 Pre-Rigging Checks
  - 3 Unit Weights
  - 3 Anchoring
- 3 Cold Weather Operation
- 3 Location
- 3 Warranties
- 3 Unit Operation

## 2 Unit Rigging & Assembly

---

- 4 Rigging
- 5 Single-Cell Installation
  - 5 Two Piece Section Assembly
- 6 Multi-Cell Installation
  - 6 Multi-Cell Unit Assembly
  - 6 Flume Box Installation
  - 8 Optional Positive Closure Plate Installation
- 9 Fan Guard Installation
  - 9 One-Piece Fan Guard
  - 10 Two-Piece Fan Guard
  - 11 Four-Piece Fan Guard
- 13 Top Inlet Piping Installation
- 15 Motor Location and Conduit Installation

## 3 Optional Accessory Installation

---

- 17 ENDURADRIVE® Fan System Installation
- 18 Whisper Quiet Fan Installation
- 20 Side Outlet Depressed Sump Box Installation
- 21 Factory Pre-Wired Terminal Box
- 21 Optional Accessories and Equipment



# Introduction

**WARNING:** Failure to use lifting provisions can result in a dropped load causing severe injury, death, and/or property damage. Lifts must be performed by qualified riggers following BAC published Rigging Instructions, and generally accepted lifting practices. The use of a supplemental safety sling may also be required if the lift circumstances warrant its use, as determined by the rigging contractor.

**CAUTION:** Only personnel qualified to do so should undertake operation, maintenance and repair of this equipment. Proper care, procedures and tools must be used in handling, lifting, installing, operating, maintaining and repairing this equipment to prevent personal injury and/or property damage.



## Safety

Adequate precautions appropriate for the installation and location of these products should be taken to safeguard the equipment and the premises from damage and the public from possible injury. **The procedures in this manual must be thoroughly reviewed prior to rigging and assembly. Read all dangers, warnings, cautions, and notes detailed in the margins.**

When the fan speed of the unit is to be changed from the factory set speed, including the use of a variable speed device, steps must be taken to avoid operating at or near the fan's "critical speed" which could result in fan failure and possible injury or damage. Consult with your local BAC Representative on any such applications.



## Shipping

BAC Cooling Towers are factory assembled to assure uniform quality and minimum field assembly. Models S3E/XES3E-8518-xxx, S3E/XES3E-1020-xxx, S3E/XES3E-1222-06x, S3E/XES3E-1222-07x, and S3E/XES3E-1424-07x ship in one section. Models S3E/XES3E-1222-10x through S3E/XES3E-1222-14x and S3E/XES3E-1424-12x through S3E/XES3E-1424-14x ship in two sections. For the dimensions and weights of a specific unit or section, refer to the certified drawings.

## Pre-Rigging Checks

When the unit is delivered to the jobsite, it should be checked thoroughly to ensure all required items have been received and are free of any shipping damage prior to signing the bill of lading.

### The following parts should be inspected:

- Sheaves and Belts / Gearbox
- Bearings
- Bearing Supports
- Fan Motor(s)
- Fan(s) and Fan Shaft(s)
- Float Valve Assembly(s)
- Water Distribution System
- Fill
- Cold Water Basin Accessories
- Interior Surfaces
- Exterior Surfaces
- Optional EASY CONNECT® Piping Arrangement (when provided)
- Louvers / Combined Inlet Shields
- Optional Air Inlet Screens (when provided)
- Mating Surfaces Between Sections / Modules
- Miscellaneous Items: All bolts, nuts, washers, and sealer tape required to assemble sections or component parts are furnished by BAC and shipped with the unit. A checklist inside the envelope marked "Customer Information Packet" indicates what miscellaneous parts are included with the shipment and where they are packed. This envelope will be attached to the side of the unit or located in a box inside the unit.



## Introduction

### Safety

### Shipping

### Pre-Rigging Checks

Unit Weights

Anchoring

### Cold Weather Operation

### Location

### Warranties

### Unit Operation



**ATTENTION:** Before an actual lift is undertaken, ensure no water, snow, ice, or debris has collected in the basin or elsewhere in the unit. Such accumulations will add substantially to the equipment's lifting weight.



**NOTE:** Each unit must be located and positioned to prevent the introduction of discharge air into the ventilation systems of the building on which the unit is located and of adjacent buildings.

## Unit Weights

Before rigging any unit, the weight of each section should be verified from the unit certified drawing. Some accessories add additional weight as shown on the respective accessory drawings.

## Anchoring

Seven-eighths (7/8") diameter holes are provided in the bottom flange of the basin section for bolting the unit to the support beams. Refer to the suggested support location drawing included in the submittal for location and quantity of the mounting holes. **The unit must be level for proper operation.** Anchor bolts must be provided by others. The IBC rating is only certified with standard anchorage locations. Using alternate anchorage locations or alternate steel supports will void any IBC wind or seismic ratings. Contact your local BAC Representative for details

## Cold Weather Operation

These products must be protected by mechanical and operational methods against damage and/or reduced effectiveness due to possible freeze-up. Please refer to the *Series 3000 Operation & Maintenance Manual* on [www.BaltimoreAircoil.com](http://www.BaltimoreAircoil.com), or contact your local BAC Representative for recommended cold weather operation strategies.

## Location

All evaporative cooling equipment must be located to ensure an adequate supply of fresh air to the unit air intakes. When units are located adjacent to walls or in enclosures, care must be taken to ensure the warm, saturated, discharge air is not deflected and recirculated back to the air intakes.

Each unit should be located and positioned to prevent the introduction of discharge air into the ventilation system of any building. For detailed recommendations on BAC equipment layout, see our website at [www.BaltimoreAircoil.com](http://www.BaltimoreAircoil.com) or contact your local Representative.

## Warranties

Please refer to the Limitation of Warranties (located in the submittal package) applicable to and in effect at the time of the sale/purchase of these products.

## Unit Operation

Prior to start-up and unit operation, refer to the *Series 3000 Operation & Maintenance Manual* shipped with the unit and also available at [www.BaltimoreAircoil.com](http://www.BaltimoreAircoil.com).

# 2

## SERIES 3000 COOLING TOWER

# Unit Rigging & Assembly

**WARNING:** Failure to use lifting provisions can result in a dropped load causing severe injury, death, and/or property damage. Lifts must be performed by qualified riggers following BAC published Rigging Instructions, and generally accepted lifting practices. The use of a supplemental safety sling may also be required if the lift circumstances warrant its use, as determined by the rigging contractor.

**NOTE:** For weight information refer to the submittal drawing package.



### Rigging

Refer to **Table 1** and **Figures 1 and 2** for the required minimum spreader bar and the recommended vertical dimension “H” from the lifting device at the base of each unit or section to the spreader bar.

**All single cell and multi cell units must be rigged one section at a time.** Models S3E/XES3E-8518-x, 1020-x, 1222-06x, 1222-07x, and 1424-07x ship in one section per cell. All other models ship in two sections per cell.

Model Number	Dimensions (For Each Section)			
	Section	Min. H	Min. W1	Min W2
S3E/XES3E-8518-x	One Section	15'	8'-6"	18'-1"
S3E/XES3E-1020-x	One Section	17'	10'	20'-1"
S3E/XES3E-1222-06x, 1222-07x	One Section	18'	12'	21'-7"
S3E/XES3E-1424-07x	One Section	20'	14'	24'-1"
S3E/XES3E-1222-10x through S3E/XES3E-1222-14x	Upper/Lower	18'/18'	12'/12'	21'-7"/21'-7"
S3E/XES3E-1424-12x through S3E/XES3E-1424-14x	Upper/Lower	20'/20'	14'/14'	24'-1"/24'-1"

Table 1. Minimum Vertical Dimension and Spreader Bar Length

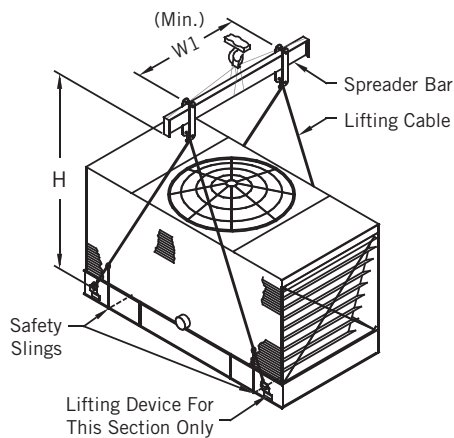

Figure 1. Lifting Instruction for Single-Cell Units: One Section Cells or Two Section Cells (Upper Section Shown)

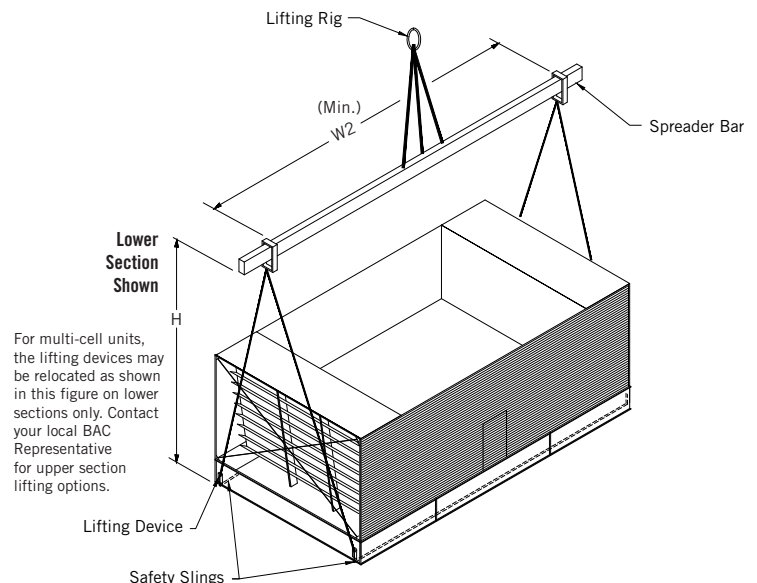

Figure 2. Lifting Instruction for Multi Cell Units: One Section Cells or Two Section Cells (Lower Section Shown)

# Single-Cell Installation



## Two Piece Section Assembly

1. Remove any accessories shipped in the cold water basin.
2. Position the lower section on the unit supports and bolt in place.
3. Wipe any moisture and dirt from the perimeter mating flanges of the lower section.
4. Install foam seal tape (BAC part # 270175) supplied with the unit, as illustrated in **Figure 3**, on the mating flanges of the lower section in a continuous line. At each corner, allow 1" overlap.
5. Complete assembly using the external bolt holes as guides for alignment:
  - Before lowering the upper section onto the lower section, be sure to line up the bolt holes using drift pins as illustrated in **Figure 5**, no fewer than one hole at each edge. Guide the upper section onto the lower section starting with a bolt hole at one corner and following down the flange.
  - Match marks must line up as shown in **Figure 3**.
  - Secure the upper section in place as shown in **Figure 4** to ensure leak-free operation.

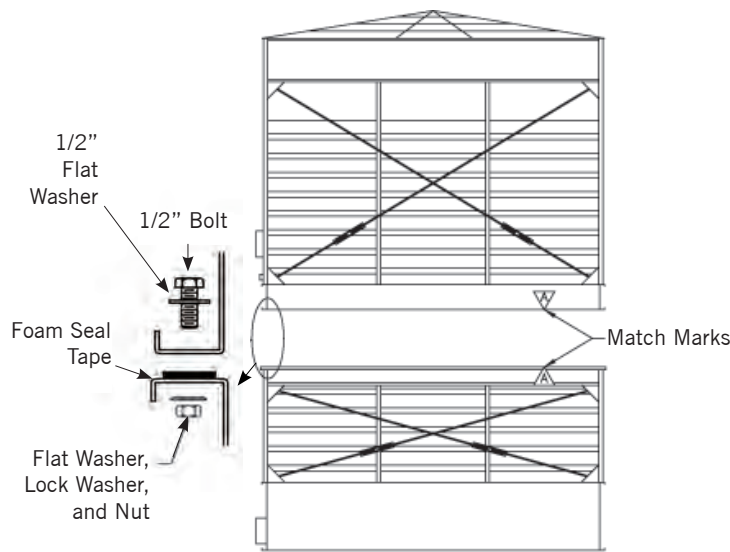

Figure 3. Upper and Lower Assembly for Series 3000 Cooling Towers

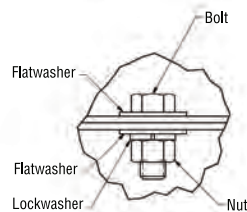

Figure 4. Typical Bolting



Figure 5. Drift Pin Alignment



**NOTE:** 1/2" bolts, flat washers, and lock washers are used.

## Multi-Cell Installation

Refer to the submittal drawings for the proper orientation of each cell. The number and “face” are stenciled on the outer basin wall. Multi-cell cooling tower installations may employ flume boxes to equalize the water level in the basin of each cell. Follow directions in “Flume Box Installation” for details on their installation.

### Multi-Cell Unit Assembly

1. First, position the lower section of all cells on the unit supports and bolt in place. Some units come furnished with a flume box. If they do, use the flume box assembly procedure outlined in “Flume Box Installation” to connect the basins of the multi-cell units.
2. Wipe any moisture and dirt from the perimeter mating flanges.
3. Install foam seal tape (BAC part # 270175) supplied with the unit, as illustrated in **Figure 3**, on **page 5** on the mating flanges of the lower sections in a continuous line. At each corner, allow 1” overlap.
4. Complete assembly using the internal drift pin alignment guides:
  - Using drift pins in the drift pin guides provided (**Figure 7**), guide the top section on to the bottom section.
  - Match marks must line up as shown in **Figure 3** on **page 5**.
  - Bolt the top sections onto the bottom sections as shown in **Figure 4** on **page 5** using the bolting channels in **Figure 6**.

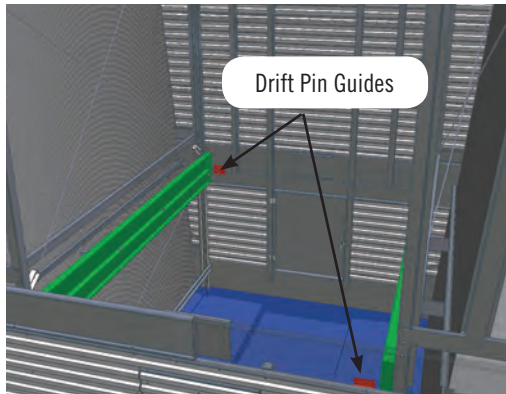

Figure 6. Upper and Lower Assembly - Drift Pin Guides

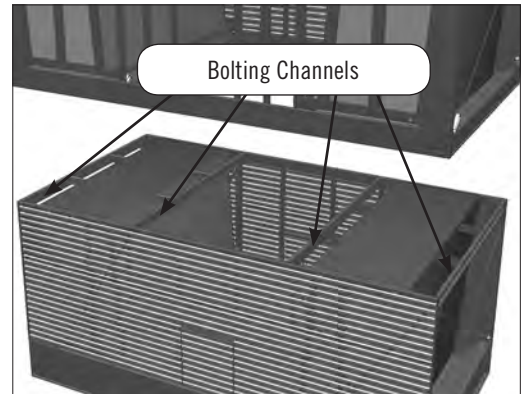

Figure 7. Bolting Channels

**NOTE:** Flume boxes furnished with units constructed with TriArmor® Corrosion Protection System or stainless steel basins are assembled with stainless steel bolts, washers and nuts in lieu of self tapping screws. Before installing the nuts, apply a lubricant to the bolts to reduce the potential for seizing.

### Flume Box Installation

1. Position Cell #1 on the unit support and bolt in place.
2. Wipe down the surface adjacent to the flume opening of Cell #1 to remove any dirt or moisture that may have accumulated during shipment.
3. Wipe down the flanges on both ends of the flume box. On one end, apply a layer of flat butyl sealer tape (BAC part # 554000) around the face of the flange over the centerline of the holes. Do not overlap or stretch too thinly at the corners. When it is necessary to splice the sealer tape, be sure to press the two ends together to form a smooth, continuous strip. Apply a second layer of flat butyl sealer tape over the first layer following the same procedure. Refer to **Figure 8, Detail A**.
4. Using drift pins to align the bolt holes, place the flume box over the opening in the basin of Cell #1.
5. Fasten into place as shown in **Figure 9**. For basins with TriArmor® Corrosion Protection System, backing plates are to be installed inside the basin and flume box opening (see **Figure 10, Detail A**). Insert the 3/8” self-tapping screws or bolts in each hole from the flume box into the basin wall and backing strips (if applicable) as illustrated in **Figure 10**.



## Multi-Cell Installation

Multi-Cell Unit Assembly

Flume Box Installation

6. Apply two layers of flat butyl sealer tape to the other end of the flume box.
7. Wipe down the surface adjacent to the flume opening of Cell #2 to remove any dirt or moisture. Position Cell #2 on the unit supports.
8. Using drift pins to assure alignment, draw Cell #2 tight against the flume box.
9. Repeat Step 5 to fasten the flume box to Cell #2.



**NOTE:** For cold water basins constructed with the TriArmor® Corrosion Protection System, attach the vertical and horizontal backing plates as shown in **Figure 10, Detail A**.

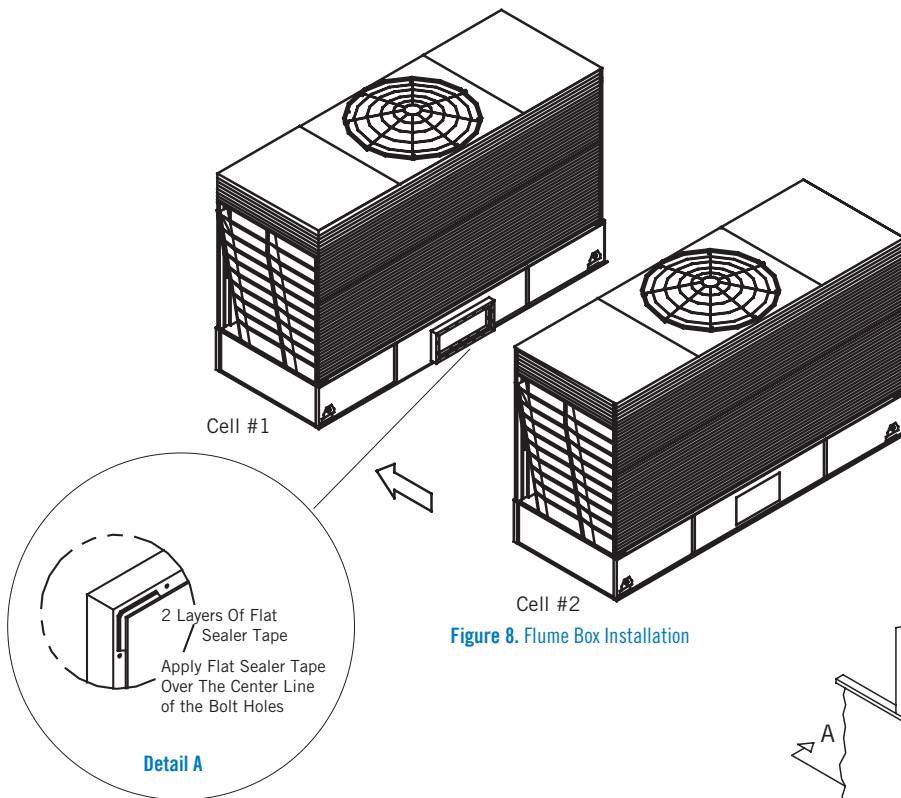

**Figure 8. Flume Box Installation**

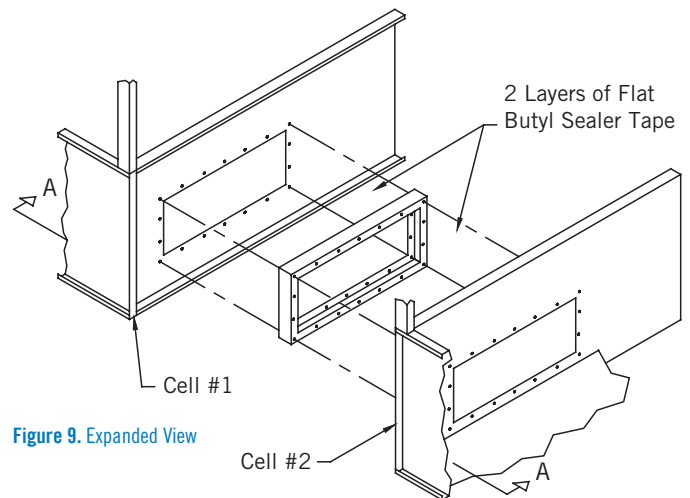

**Figure 9. Expanded View**

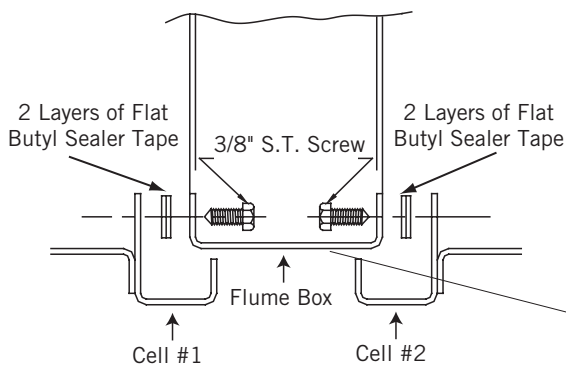

**Figure 10. Elevation View**

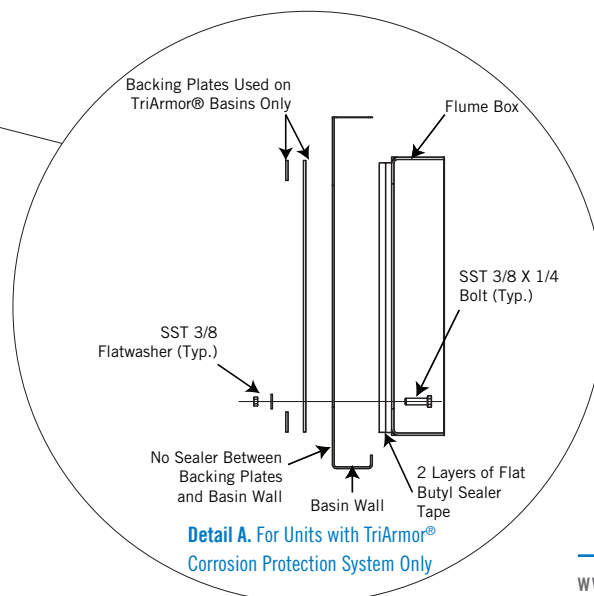

### Positive Closure Plate Installation

The optional positive closure plate and gasket can be furnished on multi-cell units to allow individual cells to be isolated for cleaning and routine maintenance. The plate ships loose inside the cold water basin.

1. Remove nuts and flat washer from the flume box.
2. Position the neoprene gasket and positive closure plate over the bolts and fasten in place with 3/8" wing nut and flat washers.
3. When the cooling tower operation does not require use of the positive closure plate, remove the closure plate and gasket. Retighten the flume box using the wing nuts and flat washers.

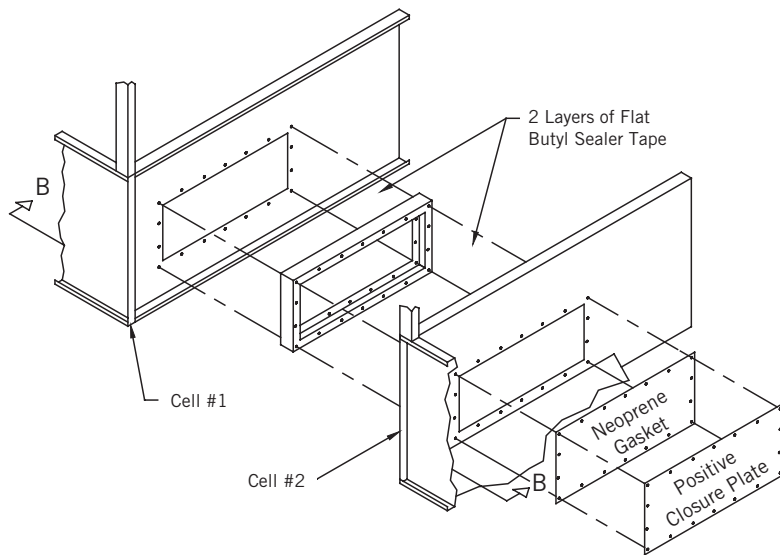

Figure 11. Expanded View

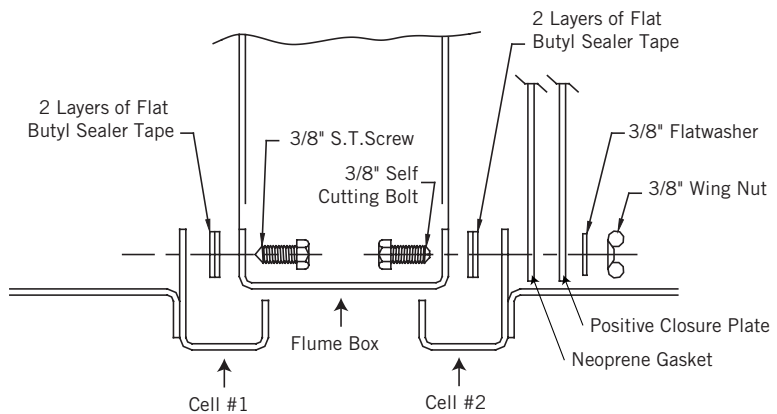

Figure 12. Elevation View



### Fan Guard Installation

Due to height limitations on truck shipments, the fan guard may ship unmounted. **Never step or walk on the fan guard when installed.** Refer to **Table 2** for the number of fan guard pieces Series 3000 Cooling Towers will have .

Model Number	Number of Fan Guard Pieces
S3E/XES3E-8518-xxx	1
S3E/XES3E-1020-xxx, 1222-xxx, 1424-07x	2
S3E/XES3E-1424-12x, 1424-13x, 1424-14x	4

Table 2. Number of Fan Guard Pieces

### One-Piece Fan Guard

Mount fan guard to unit as illustrated in **Figure 13, Detail A.**

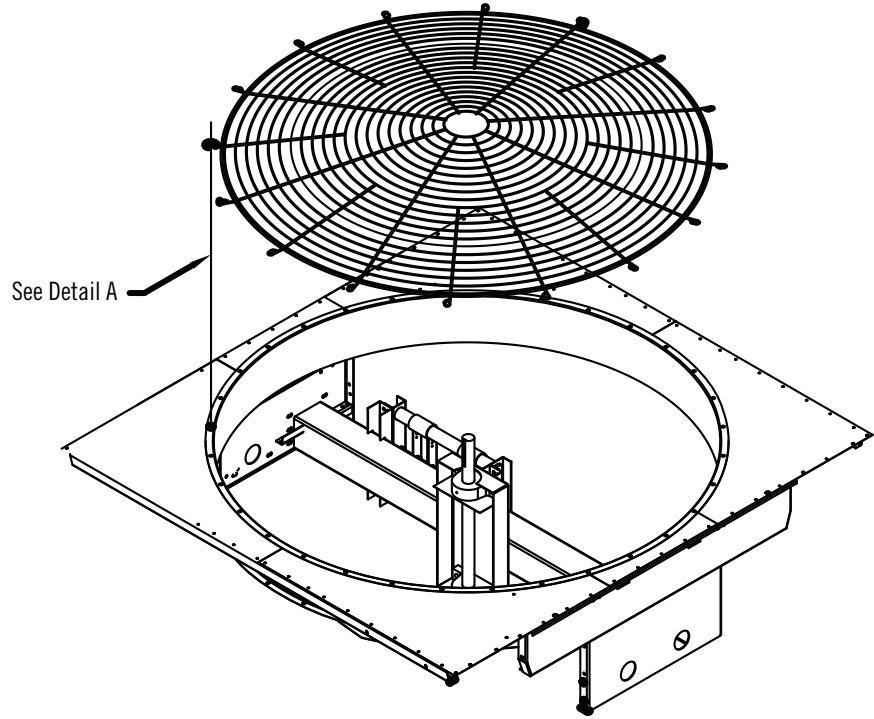
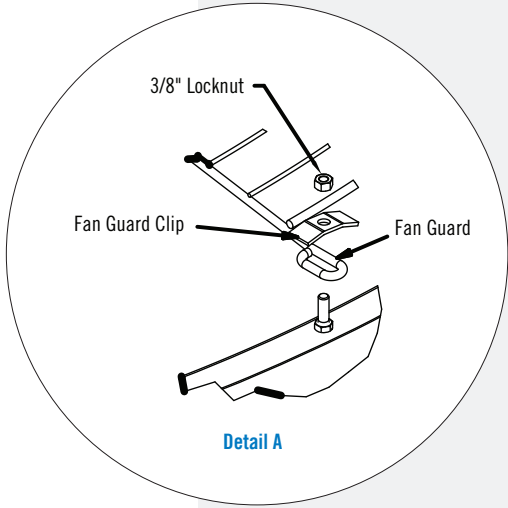

Figure 13. One-Piece Fan Guard Assembly



### Multi-Cell Installation

Optional Positive Closure Plate

### Fan Guard Installation

One-Piece Fan Guard



**DANGER:** Fan guard must be securely in place before the cooling tower is placed in operation. Never step or walk on the fan guard. Failure to follow these instructions may result in serious injury or death.



**NOTE:**  
1. Existing 3/8" stud and nut for guard mounting at fan deck level (3/8" x 1 1/2" bolt for guards mounted on top of cowl extensions).

**DANGER:** Fan guard must be securely in place before the cooling tower is placed in operation. Never step or walk on fan guard. Failure to follow these instructions may result in serious injury or death.



### Two-Piece Fan Guard

1. Using six U-bolt assemblies, fasten the two halves of the fan guard together as illustrated in **Figure 14, Detail B**. Locate the U-bolt assemblies along the seam between the two guard halves per the X and Y dimension provided in **Table 3**, which are based on the diameter of the supplied fan.
2. Gradually tighten both nuts of the U-bolt assembly, alternating from one to the other, until 20-25 ft-lb of torque is achieved.
3. Mount the fan guard to the unit as illustrated in **Figure 14, Detail A** for the ends of the seam where the two guard halves join together, and **Detail C** for all other locations around the fan guard perimeter.

Fan Diameter	X	Y
9'	10"	17"
10'	10"	20"
11'	10"	23"

**Table 3.** -U-Bolt Location Dimensions for Two-Piece Fan Guard Fastening

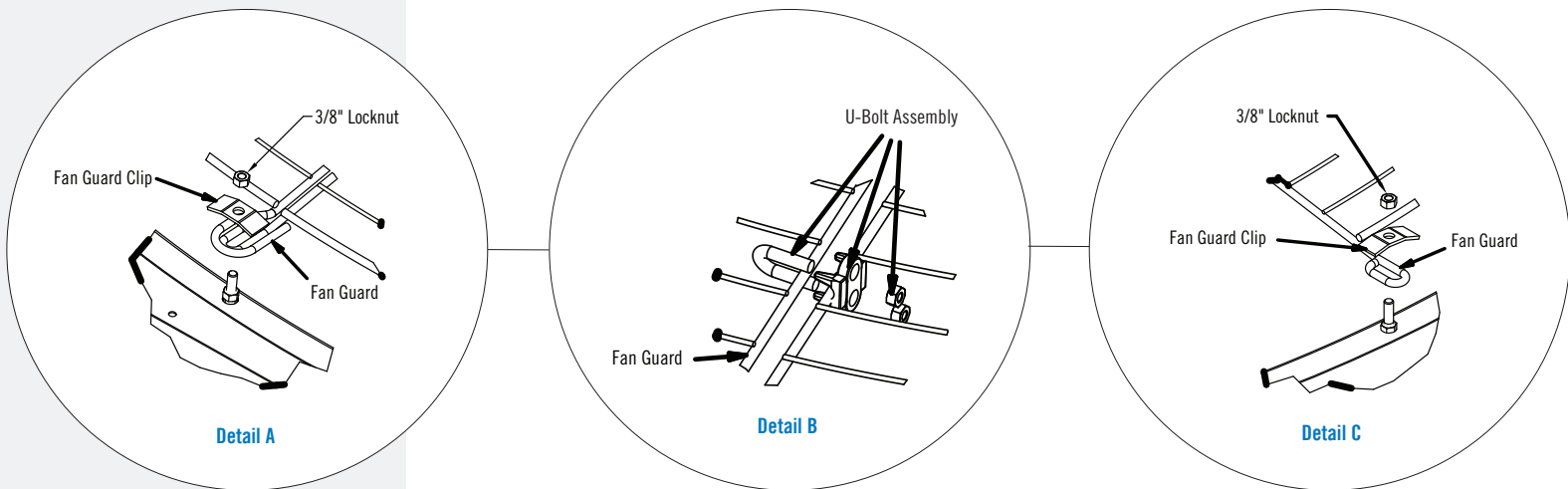

**NOTE:** For guards mounted at fan deck level, fasten the guard perimeter to existing 3/8" threaded studs protruding up from fan deck. For guards mounted to the top of fan cowl extension(s), fasten the guard perimeter using 3/8" x 1-1/2" long bolts supplied with fan guard hardware.

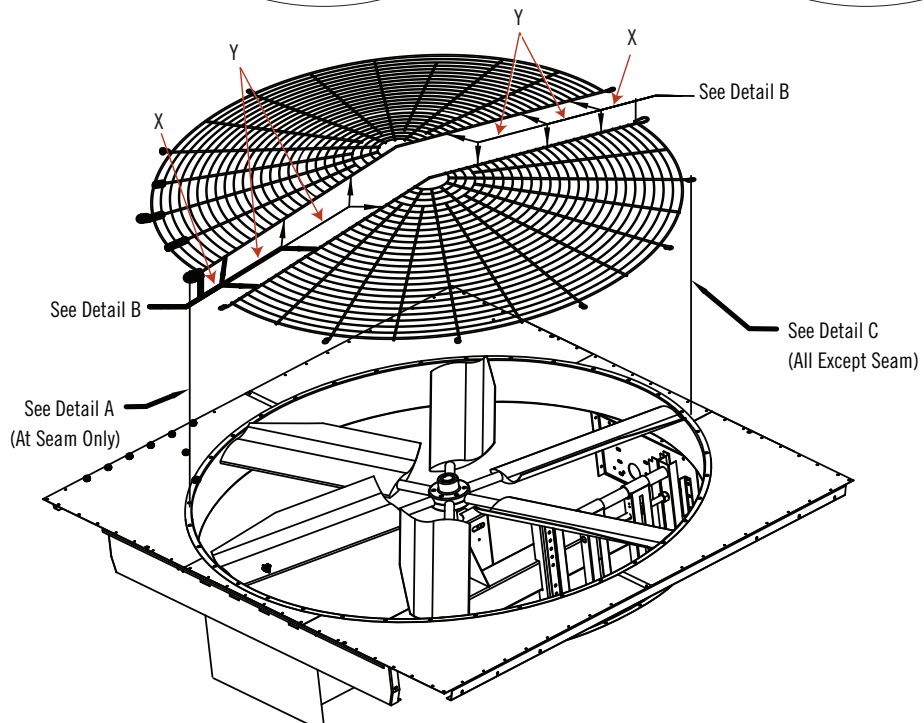

**Figure 14.** Two-Piece Fan Guard Assembly

## Four-Piece Fan Guard

1. Assemble fan guard supports as illustrated in **Figure 15, Detail A**.
2. Secure fan guard pieces to fan guard supports as shown in **Figure 15, Detail B**.
3. Mount fan guard assembly to unit as shown in **Figure 15, Detail C**.

## Fan Guard Installation

- Two-Piece Fan Guard
- Four-Piece Fan Guard

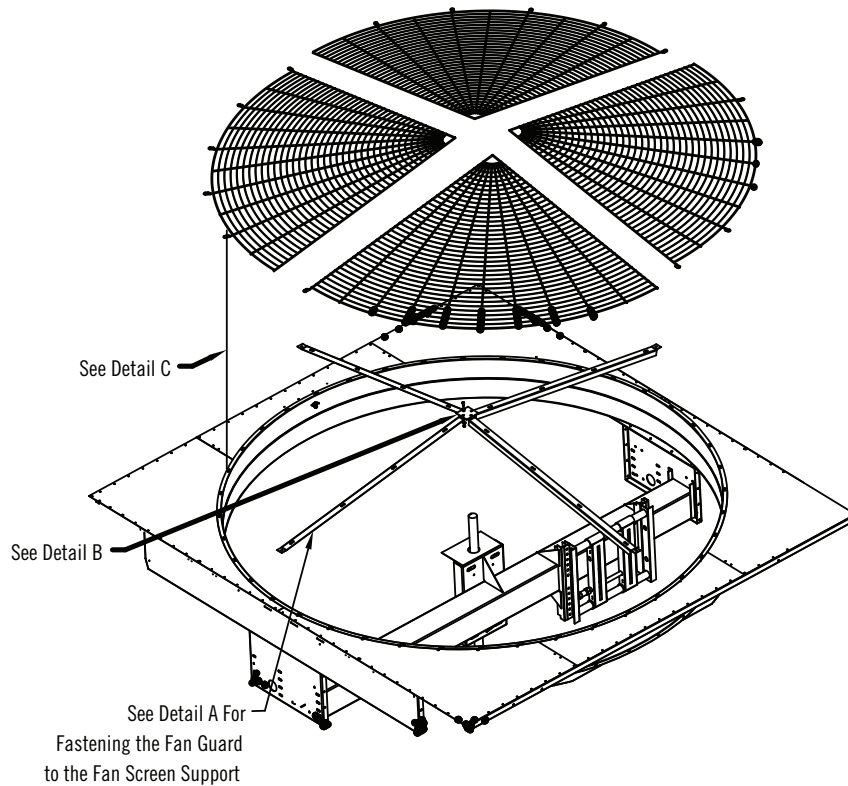

Figure 15. Four-Piece Fan Guard Assembly



**DANGER:** Fan guard must be securely in place before the cooling tower is placed in operation. Never step or walk on the fan guard. Failure to follow these instructions may result in serious injury or death.



**NOTE:**  
1. Existing 3/8" stud and nut for guard mounting at fan deck level (3/8" x 1 1/2" bolt for guards mounted on top of cowl extensions).

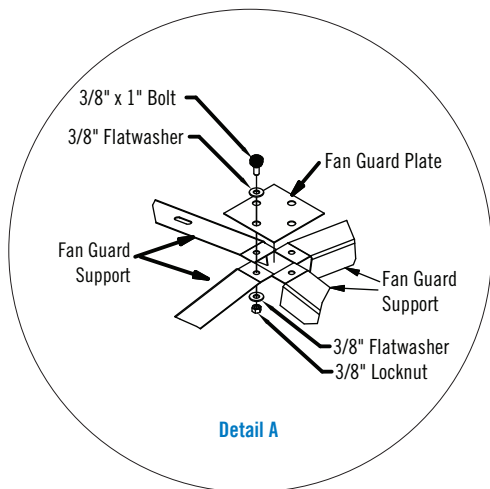

Detail A

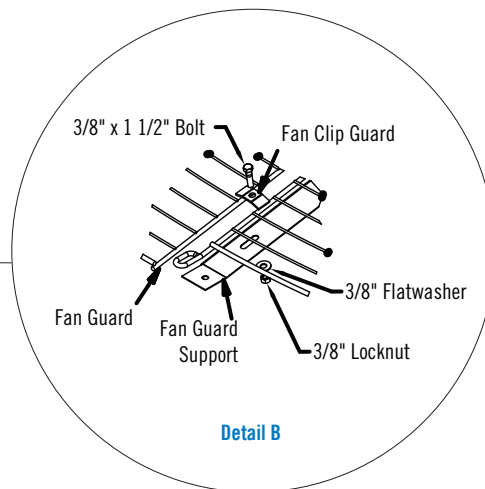

Detail B

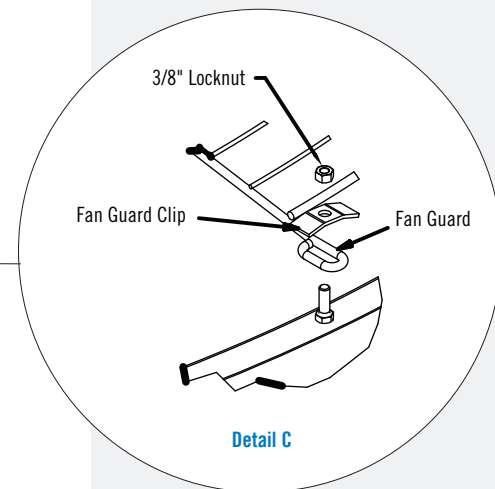

Detail C

**NOTES FOR FIGURE 16:**

1. All piping shown by dashed lines is to be furnished by others. Refer to the certified unit print for details on the cooling tower.
2. Field piping should be fabricated at the time of unit installation. Pre-fabrication of pipe work is not recommended.
3. Required static pumping head from base of cooling tower is indicated by static lift dimension and piping friction losses.
4. When tower is equipped with safety railing package, inlet piping should be designed to clear the railing. Adjust static lift as required.
5. For units installed on vibration isolation rails (provided by others), flexible connections should be installed in the piping just before the tower perimeter.
6. All piping supports to be designed, furnished, and installed by others.
7. Supply piping to cooling tower inlet connections may be supported from the tower structure only at the pipe support locations shown. Piping must not be supported by the tower inlet connections. Piping outside the perimeter of the tower must not be supported from the tower.
8. Supply piping supports must be designed to rest on the walls of the hot water distribution basins at locations indicated (see **Figure 18, Detail A**).
9. Maximum diameter of inlet header piping that can be supported by the cooling tower distribution basins is 14".
10. Provide adequate space between cooling tower and riser piping to allow for entry into the cooling tower access doors.



## Top Inlet Piping Installation

Use the following drawings, notes, and tables when installing top inlet piping. Drawings shown are for multi-cell installations. For single cell installations, simply ignore the additional cells and dimension "C" from **Table 4**.

Model Number	A	B	C	H
S3E/XES3E-8518-05x	10'-6 3/4"	4'-2 7/8"	8'-8 1/4"	8'-7 3/4"
S3E/XES3E-8518-06x	10'-6 3/4"	4'-2 7/8"	8'-8 1/4"	9'-11 3/4"
S3E/XES3E-8518-07x	10'-6 3/4"	4'-2 7/8"	8'-8 1/4"	11'-3 3/4"
S3E/XES3E-1020-06x	12'-6 3/4"	4'-10 5/8"	9'-11 3/4"	9'-11 3/4"
S3E/XES3E-1020-07x	12'-6 3/4"	4'-10 5/8"	9'-11 3/4"	11'-3 3/4"
S3E/XES3E-1222-06x	14'-0 3/4"	5'-10 7/8"	12'-0 1/4"	9'-11 3/4"
S3E/XES3E-1222-07x	14'-0 3/4"	5'-10 7/8"	12'-0 1/4"	11'-3 3/4"
S3E/XES3E-1222-10x	14'-0 3/4"	5'-10 7/8"	12'-0 1/4"	15'-5 1/2"
S3E/XES3E-1222-12x	14'-0 3/4"	5'-10 7/8"	12'-0 1/4"	18'-1 1/2"
S3E/XES3E-1222-13x	14'-0 3/4"	5'-10 7/8"	12'-0 1/4"	19'-5 3/4"
S3E/XES3E-1222-14x	14'-0 3/4"	5'-10 7/8"	12'-0 1/4"	20'-9 1/2"
S3E/XES3E-1424-07x	16'-6 3/4"	6'-11 9/16"	14'-1 5/8"	11'-3 3/4"
S3E/XES3E-1424-12x	16'-6 3/4"	6'-11 9/16"	14'-1 5/8"	18'-1 1/2"
S3E/XES3E-1424-13x	16'-6 3/4"	6'-11 9/16"	14'-1 5/8"	19'-5 3/4"
S3E/XES3E-1424-14x	16'-6 3/4"	6'-11 9/16"	14'-1 5/8"	20'-9 1/2"

**Table 4. Dimensions for Series 3000 Piping Schematic**

Size	Width
6"	2 1/4"
8"	2 1/2"
10"	2 13/16"

**Table 5. Flow Control Valve**

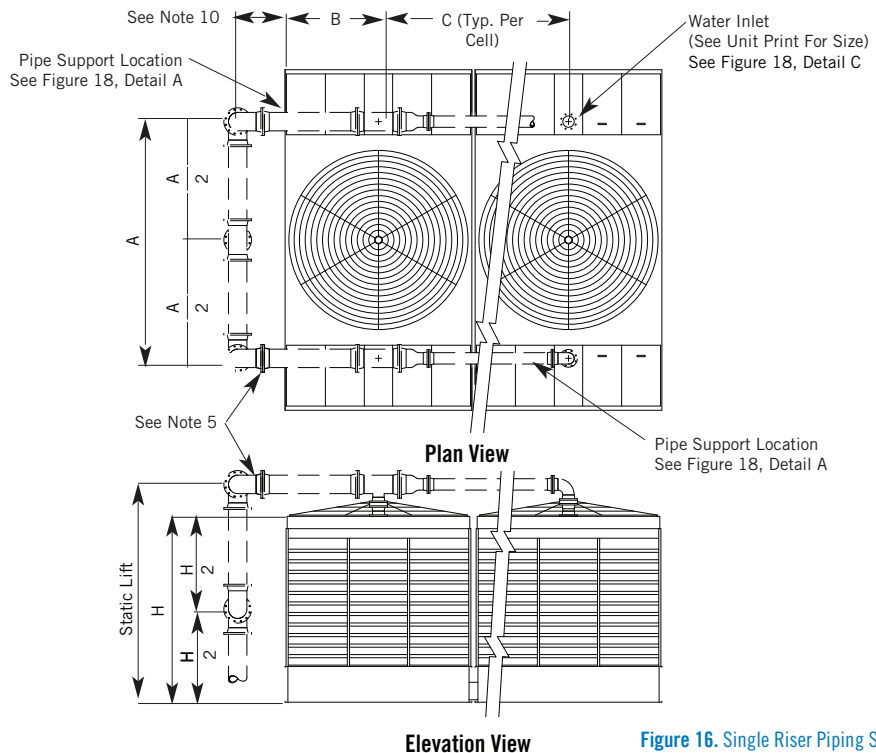

**Figure 16. Single Riser Piping Schematic**



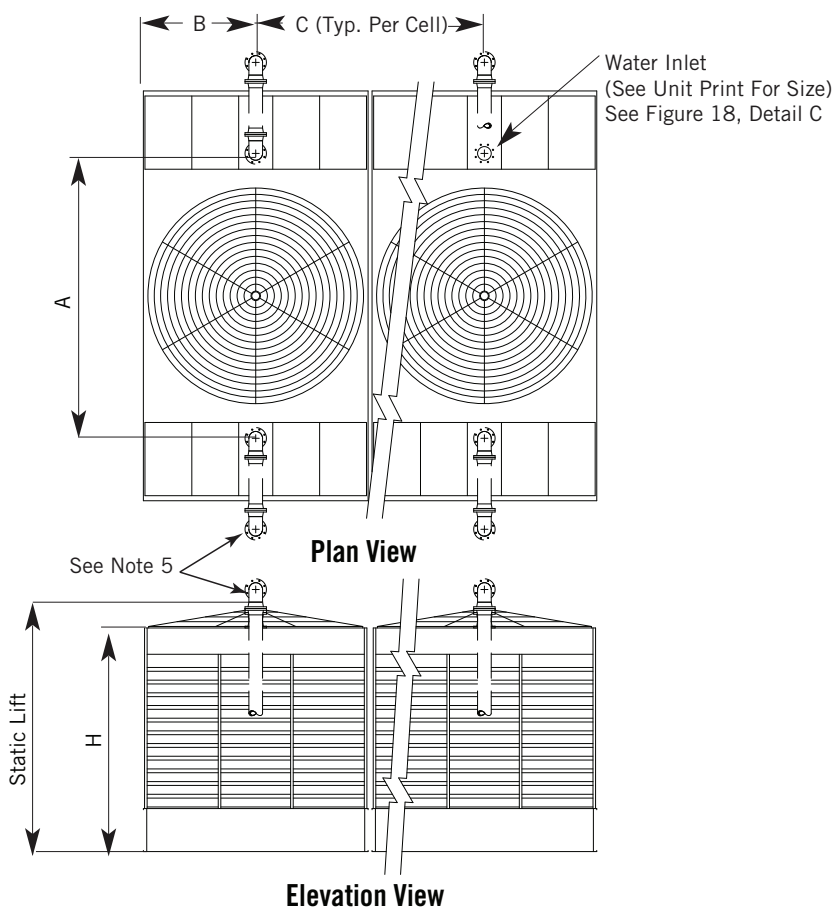
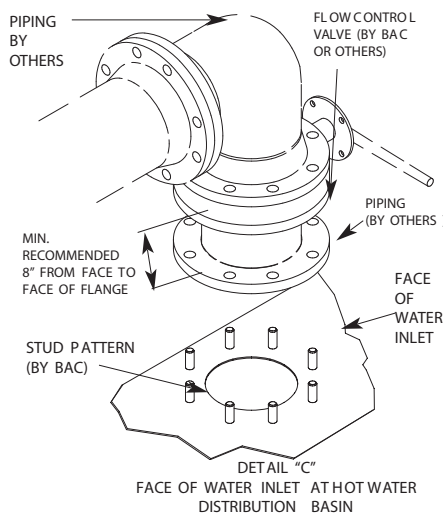
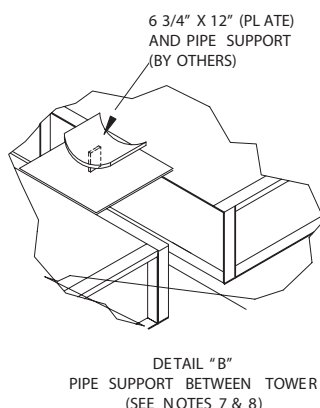
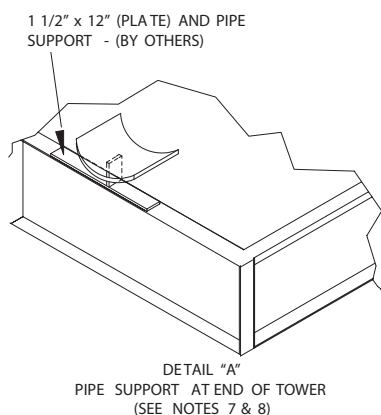

Figure 17. Dual Riser Piping Schematic

### NOTES FOR FIGURE 17:

1. All piping shown by dashed lines is to be furnished by others. Refer to the certified unit print for details on the cooling tower.
2. Field piping should be fabricated at the time of unit installation. Pre-fabrication of pipe work is not recommended.
3. Required static pumping head from base of cooling tower is indicated by static lift dimension and piping friction losses.
4. When tower is equipped with safety railing package, inlet piping should be designed to clear the railing. Adjust static lift as required.
5. For units installed on vibration isolation rails (provided by others), flexible connections should be installed in the piping just before the tower perimeter.
6. All piping supports to be designed, furnished, and installed by others.
7. Supply piping to the cooling tower inlet connections must not be supported from the tower.



Piping by others. Flow control valves available by BAC or others, and always installed by others.

Figure 18. Piping Drawing Details

**NOTE:**

- Weights given represent the additional weight when a 2-speed motor is ordered and should be added to the standard unit weight.
- If the optional BALTIGUARD™ Fan System is ordered, weights given are for each BALTIGUARD motor and should be added to the standard unit weight.

**NOTES FOR FIGURES 19-21:**

- Conduit must be water tight and pitched downward to allow condensation to drain away from fan motor conduit box. Therefore, do not run the conduit through fan deck.
- All wiring must conform to local and national electrical codes. Junction box/safety switch and all conduit from fan motor conduit box to be sized, provided, and installed by others.
- Rigid conduit outside casing panel must turn down to junction box.
- On multi-cell units, use separate conduit lines for each fan motor. Run conduit through adjacent cells to junction box and or disconnect switch on front/rear cell.

Number of Cells	Configuration
1	CT-1
2	CT-1 & CT-4
3	CT-1, CT-2 & CT-4
4	CT-1 through CT-4

## Motor Location and Conduit Installation

Use the following drawings and notes when installing electrical conduit for cooling towers supplied with the BALTIDRIVE® Power Train, BALTIGUARD™ Fan System, gear drives, or the ENDURADRIVE® Fan System. Notice the table for weight adds for two-speed motors and the BALTIGUARD™ Fan System.

2-Speed Motor Weight Add	
Motor HP	Weight (lbs)
7.5	140
10	185
15	90
20	80
25	210
30	170
40	225
50	300
60	425
75	340
100 (gear only)	600

Table 6. 2-Speed Motor Weight Add<sup>(1)</sup>

BALTIGUARD™ Fan System Motor Weight Add	
Motor HP	Weight (lbs)
3	100
5	110
7.5	160
10	175
15	300
20	260
25	390
30	440

Table 7. BALTIGUARD™ Fan System Motor Weight Add<sup>(2)</sup>

Weights given in **Tables 6** and **7** represent the additional weight when an optional 2-speed motor or BALTIGUARD™ Fan System is ordered. These weights should be added to the standard unit weight.

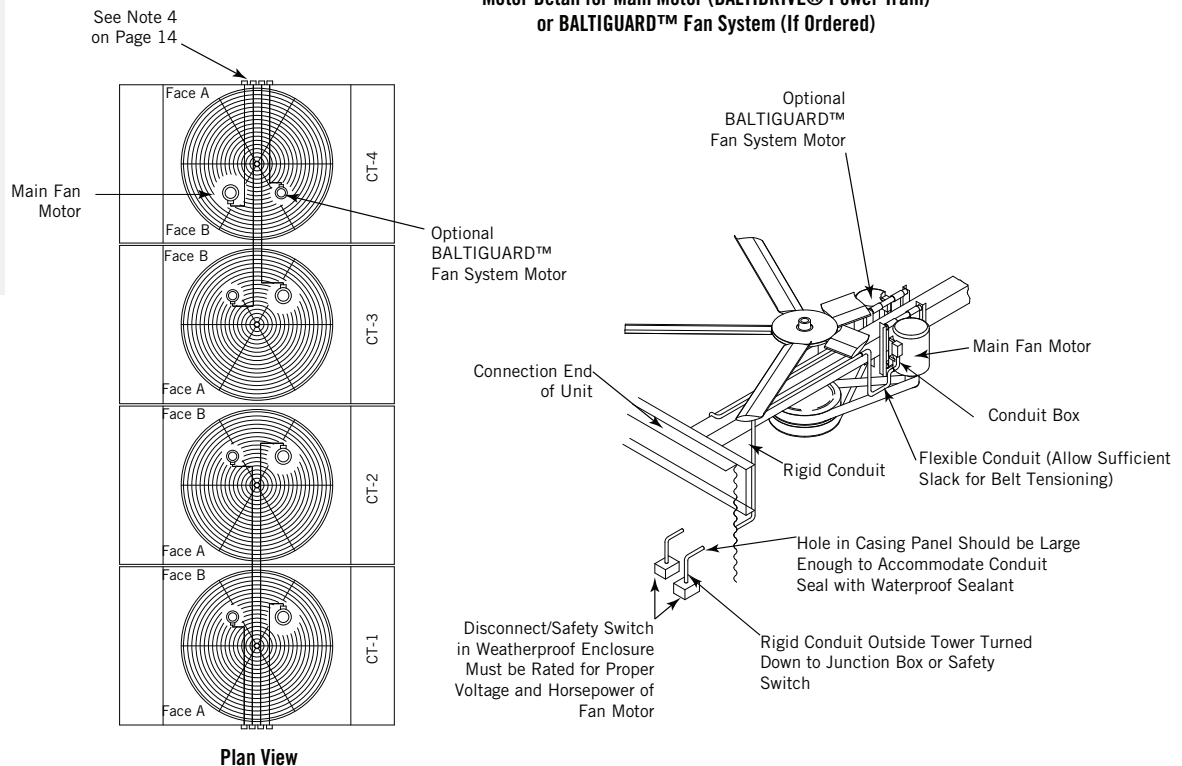
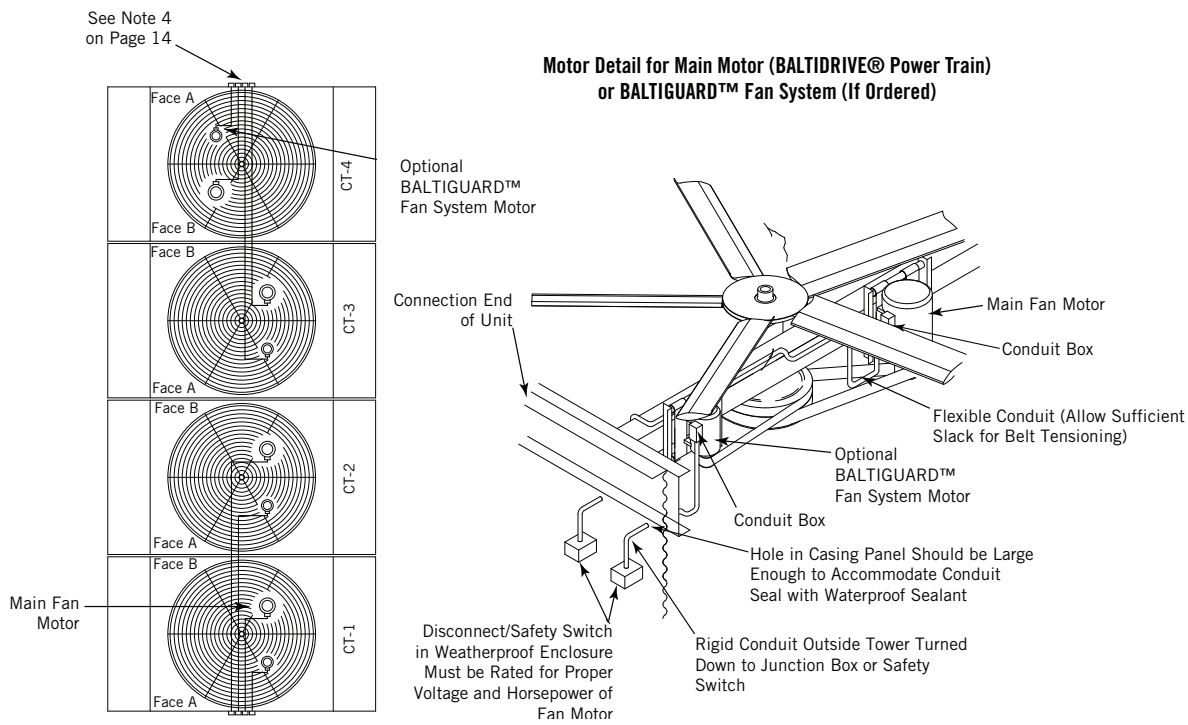

Figure 19. Belt Drive Motor Location(s) for Models that Ship in One Section





Number of Cells	Configuration
1	CT-1
2	CT-1 & CT-4
3	CT-1, CT-2 & CT-4
4	CT-1 through CT-4

Figure 20. Belt Drive Motor Location(s) for Models that Ship in Two Sections

Number of Cells	Configuration
1	CT-1
2	CT-1 & CT-4
3	CT-1, CT-2 & CT-4
4	CT-1 through CT-4

External Fan Motor Detail

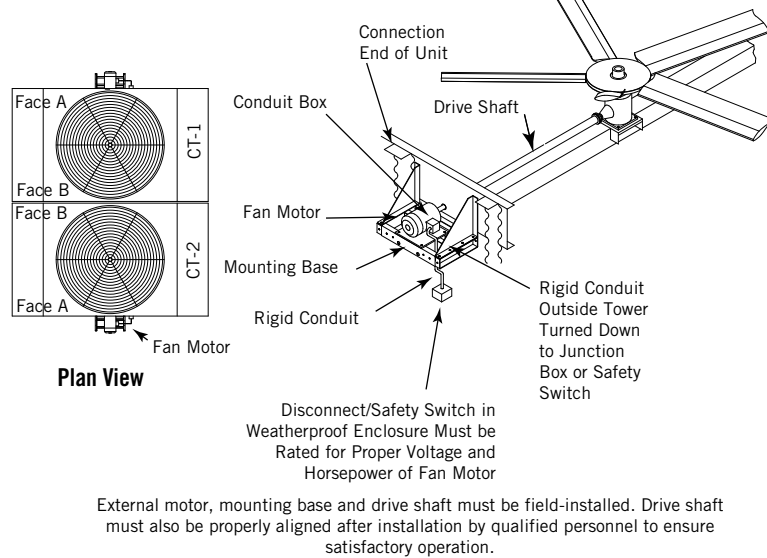

Figure 22. External Fan Motor Location for Gear Drive

Close-Coupled Gear Drive Motor Detail

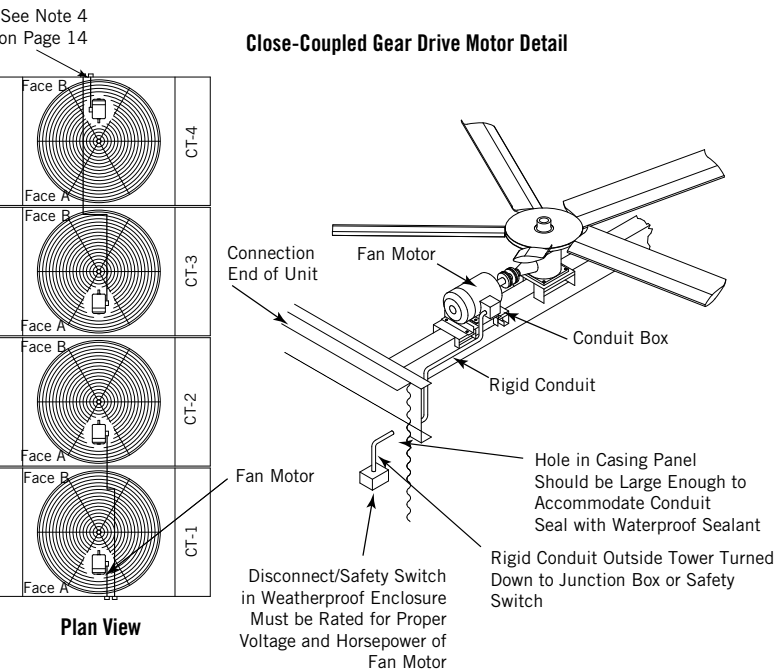

Figure 21. Motor Location For Close-Coupled Gear Drive

### ENDURADRI<sup>®</sup> Fan System Motor Detail

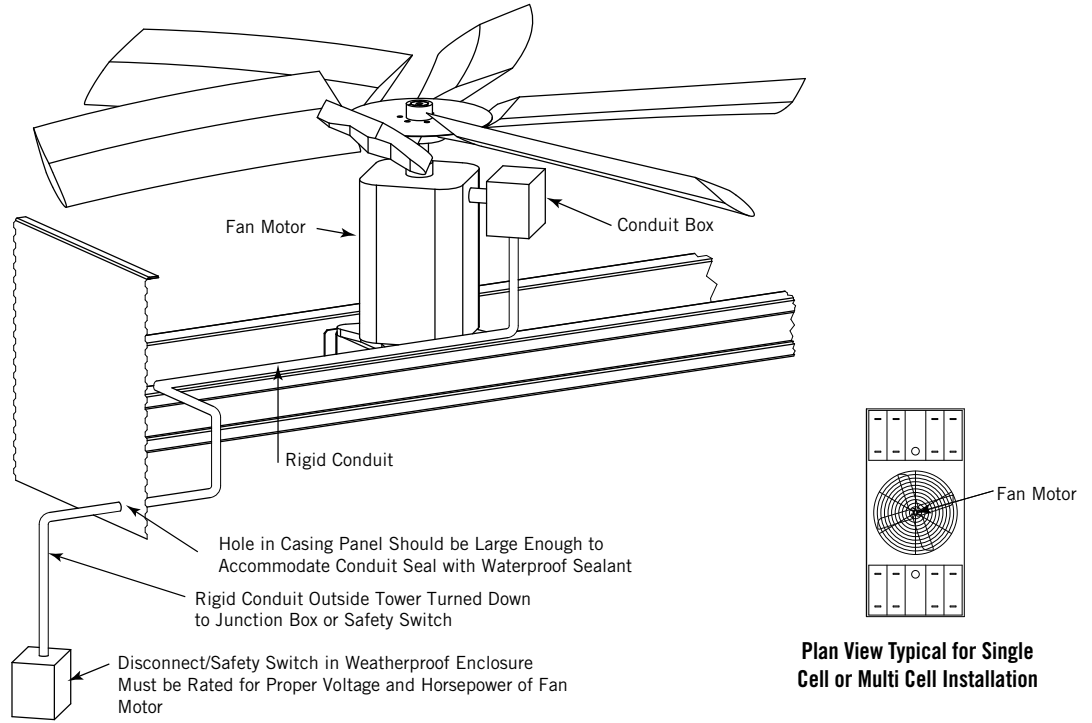

Figure 23. Motor Location For the ENDURADRI<sup>®</sup> Fan System

# Optional Accessory Installation



## ENDURADRI<sup>®</sup> Fan System Installation (Optional)

The ENDURADRI<sup>®</sup> Fan System is an option for select Series 3000 Cooling Towers and is standard on S3E-1424-14U and S3E-1424-14W models. The ENDURADRI<sup>®</sup> Fan System variable frequency drive (VFD) is to be installed per the *ACS880+N5350 Cooling Tower Drives User's Guide* available at [www.abb.com](http://www.abb.com). The fan motor must be wired directly into the VFD and cannot be wired across the line. For wiring details, refer to the submittal drawings.



### Warnings for the ENDURADRI<sup>®</sup> Fan System

- **WARNING:** ENDURADRI<sup>®</sup> Fan System motors can induce voltage and current in the motor leads by rotating the motor shaft, even when the motor is completely disconnected from the power source. Electrical shock can cause severe personal injury or death. Therefore, mechanically lock or tie down the fan until all wiring has been completed and before servicing the drive system, or when performing any motor maintenance procedure. Only qualified personnel should attempt the installation, operation and maintenance of this equipment.
- **WARNING:** Pacemaker danger – Magnetic and electromagnetic fields in the vicinity of current carrying conductors and ENDURADRI<sup>®</sup> Fan System motors can result in a serious health hazard to persons with cardiac pacemakers, metal implants, and hearing aids. To avoid risk, stay away from the area surrounding the ENDURADRI<sup>®</sup> Fan System motor.
- **WARNING:** The VFD may apply hazardous voltages to the motor leads after power to the controller has been turned off. Verify that the controller is incapable of delivering hazardous voltages and that the voltage at the motor leads is zero before proceeding. Failure to comply with this warning may result in severe personal injury or death.



### Attentions for the ENDURADRI<sup>®</sup> Fan System

- VFD must be powered on at all times so that trickle current can remove moisture from motor when idle.
- Use only a shielded motor power cable with a complete circumferential braided or copper film/tape ground jacket around the power leads. This ground should be secured to the motor frame from within the motor terminal box and must return without interruption to the drive ground.
- To prevent equipment damage, be sure that the electrical service is not capable of delivering more than the maximum motor rated amps listed on the rating plate.

**NOTE:** Refer to the “Customer Information Packet” for additional instructions for the specific cooling tower model.



## Whisper Quiet Fan Installation (Optional)

The optional Whisper Quiet Fan will ship with blades assembled to the prescribed pitch and hardware torque. Depending on the model number, the fan will ship installed or crated. Refer to **Table 8** for more shipping methods and fan weights. If the whisper quiet fan is shipped installed, no additional steps are needed.

Model	Belt	Internal Motor	External Motor	Fan Weight (lbs)
1020-06J, -06L	Installed	Crated	Installed	390
1020-06K, -06M, -06N	Installed	Crated	Crated	390
1020-07x	Crated	Crated	Crated	390
1222-06x	Installed	Crated	Crated	410
1222-07x	Crated	Crated	Crated	410
1222-10x	Installed	Installed	Installed	560
1222-12x	Installed	Installed	Installed	560
1222-13x	Installed	Installed	Installed	560
1222-14x	Crated	Crated	Crated	560
1424-07x	Crated	Crated	Crated	450
1424-12x	Installed	Installed	Installed	620
1424-13x	Installed	Installed	Installed	620
1424-14x	Crated	Crated	Crated	620

**Table 8.** Whisper Quiet Fan Shipping Matrix

**ATTENTION:** Do not use power tools on the whisper quiet fan.



### Crated Whisper Quiet Fan Installation

1. Remove fan seal disk (**Figure 24**).
2. Wrap or loop slings around blade shanks (**Figure 25**).
3. Remove bolt, PVC spacer, and plywood spacers from the shipping mount (**Figure 26**).
4. Lift the fan off the shipping crate. Be careful not to damage blades (**Figure 27**).
5. Position the fan over the top of the keyed fan shaft (**Figure 28**).
6. Line up the key with the slot. Slowly lower the fan onto the shaft until the fan hub is flush against the factory installed tangent locking collar (**Figure 29**).
7. Gradually tighten the bushing bolts in several passes to evenly seat the tapered bushing into the hub flange, and lock the bushing to the shaft (**Figure 30**). Refer to **Table 9** which lists the prescribed torques for the bushing bolts.
8. Replace fan seal disk, and tighten bolts until rubber seal washer compress to the diameter of the flat washers (**Figure 31**).

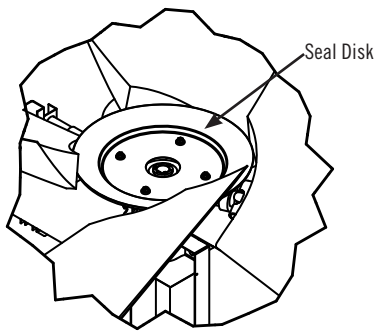

Figure 24. Remove Seal Disk

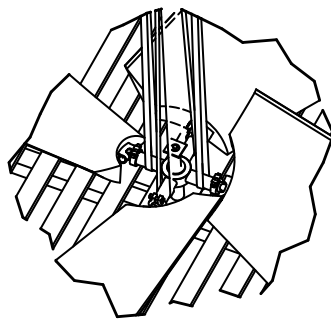

Figure 25. Attached to Blade Shanks

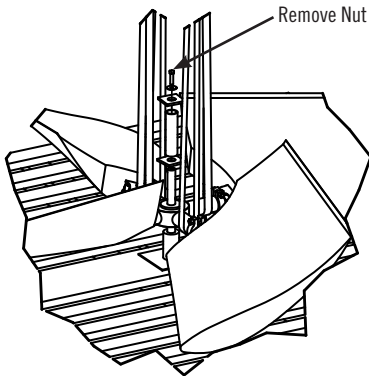

Figure 26. Remove Shipping Restraint Hardware

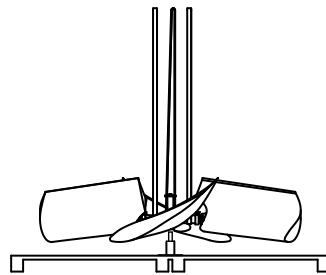

Figure 27. Lift Fan From Crate

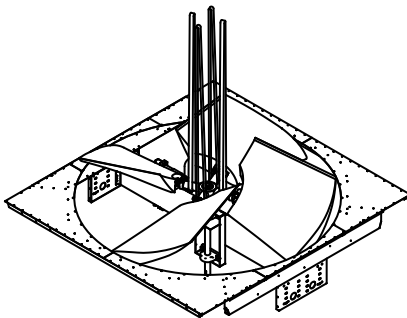

Figure 28. Fan Positioning

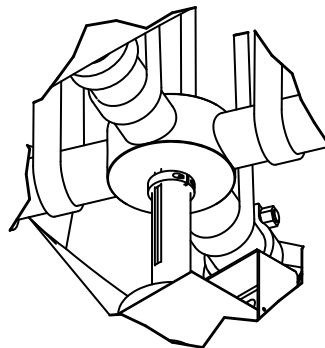

Figure 29. Key Lineup

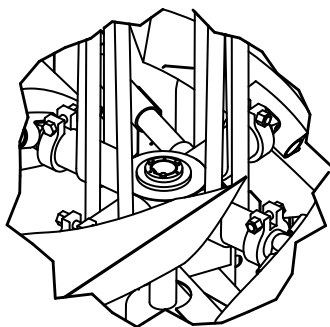

Figure 30. Bushing Bolts

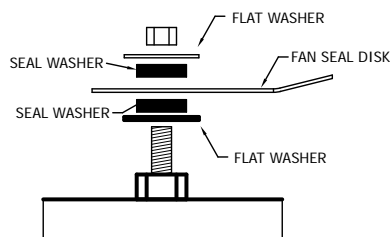

Figure 31. Replace Seal Disk

Model Number	Bushing Type	Bushing O.D.	Hex Key Size	Torque
1020-x	U	4"	10mm	50 Ft-Lb
1222-x, 1424-x	W	5.5"	14mm	90 Ft-Lb

Table 9. Bushing Torque

## Side Outlet Depressed Sump Box Installation (Optional)

The optional side outlet depressed sump box allows a cooling tower water outlet connection to be piped from underneath the unit in four possible directions, 90° apart. The piping connection is a bolt circle designed to fit an ASME Class 150 flat face flange with a full-face gasket.

**To install the side outlet depressed sump box, follow the steps below:**

1. Wipe the edges around the opening inside the cold water basin to remove any dirt or moisture that may have accumulated during shipment.
2. Apply a layer of trapezoidal butyl sealer tape (BAC part #554009) around the opening in the basin over the centerline of the holes. Do not stretch the sealer tape too thinly or overlap at the corners. When it is necessary to splice the sealer tape, be sure to press the two ends together to form a smooth continuous strip. Apply a second layer of trapezoidal butyl sealer tape (BAC part #554009) over the first layer following the same procedure. Refer to **Figure 32**. The sealer tape needs to be positioned between the sump box and the inside basin bottom centered over the bolt holes.
3. Insert the sump box assembly into the opening in the cold water basin and attach it to the basin with 3/8" x 1" bolts, flat washers, lock washers, and nuts as shown in **Figure 32, Detail A**.
4. Place the suction strainer over the opening.

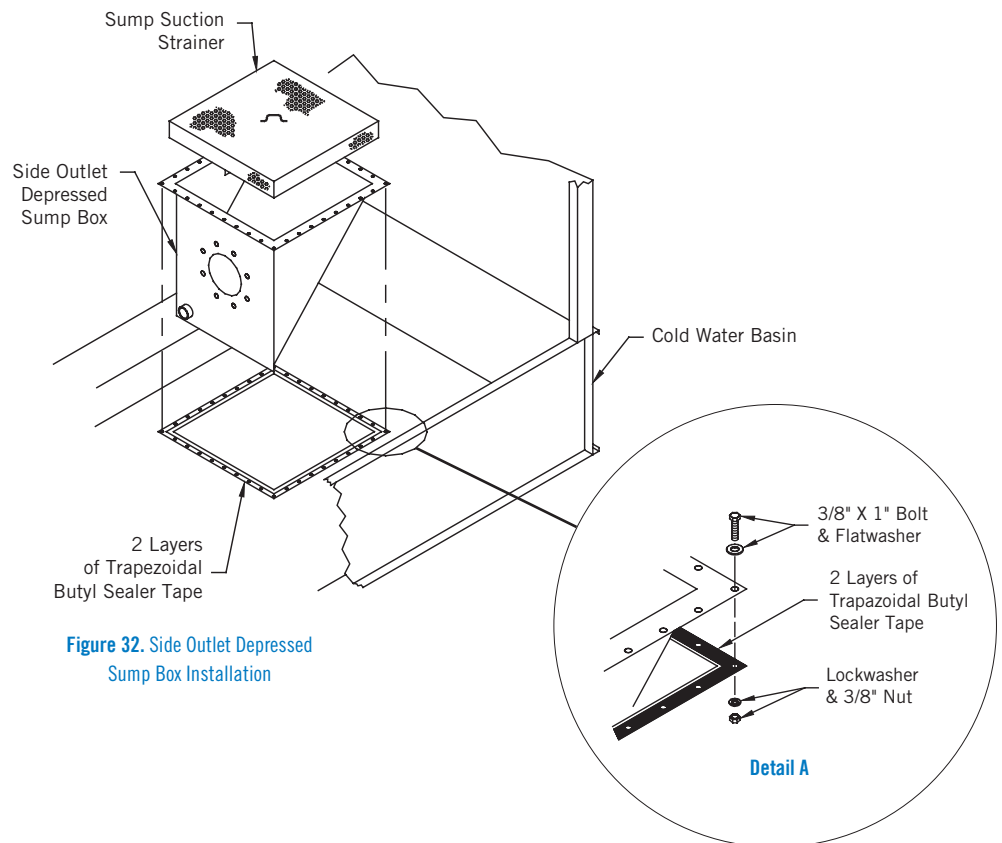

**Figure 32.** Side Outlet Depressed Sump Box Installation



### Factory Pre-Wired Terminal Box (Optional)

BAC offers an optional terminal box with factory pre-wiring for Series 3000 Cooling Towers. When this option is ordered, the cooling tower's fan motor(s) and vibration cutout switch are wired at the factory (through flexible conduit and the mechanical equipment support) and terminated on the outside face of the BAC unit in a clearly marked, 304 Stainless Steel, NEMA 3R terminal box (see **Figure 33** for the exterior location of the box on the cooling tower).

The box includes a cover plate, which once removed reveals an easy-to-follow wiring diagram and modular terminal blocks. Remove the cover plate, and install the collar (ships loose in the cooling tower's basin) which has prepunched conduit holes. Wiring from the terminal blocks to the unit controls is sized, provided and installed by others. After the controls are wired, reinstall the cover plate on the terminal box.

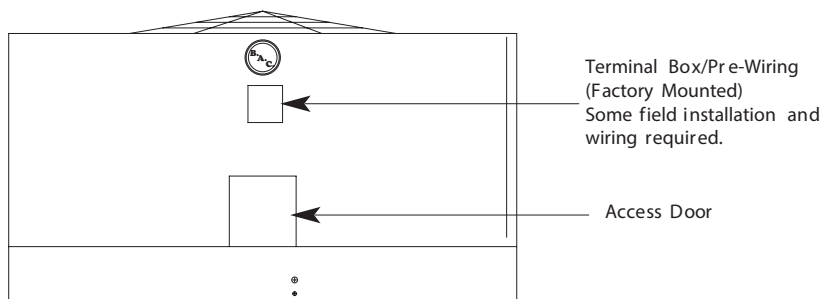

Figure 33. Factory Pre-Wired Terminal Box Location

### Additional Optional Accessories and Equipment

All platforms, ladders, safety cages, and VR stacks will be factory assembled and will ship pre-assembled for field installation. **All optional accessories should be installed after the unit is rigged.** These pre-assembled options should be installed on the cooling tower as shown on the appropriate reference drawing in the "Customer Information Packet." Installation for additional optional accessories should also be installed as shown on the appropriate reference drawing in the "Customer Information Packet." This packet will be in an envelope attached to the side of the unit or located in a box inside the unit.

Side Outlet Depressed Sump Box

Factory Pre-Wired Terminal Box

Additional Optional Accessories and Equipment

## COOLING TOWERS

---

CLOSED CIRCUIT COOLING TOWERS

---

ICE THERMAL STORAGE

---

EVAPORATIVE CONDENSERS

---

HYBRID PRODUCTS

---

PARTS & SERVICES



[www.BaltimoreAircoil.com](http://www.BaltimoreAircoil.com)

7600 Dorsey Run Road, Jessup, MD 20794 › Telephone: (410) 799-6200 › Fax: (410) 799-6416

© 2017 Baltimore Aircoil Company › R-244/8-B-XE