

# Series 54 and S54 Resilient Couplings

## Bibby Transmissions Resilient Couplings

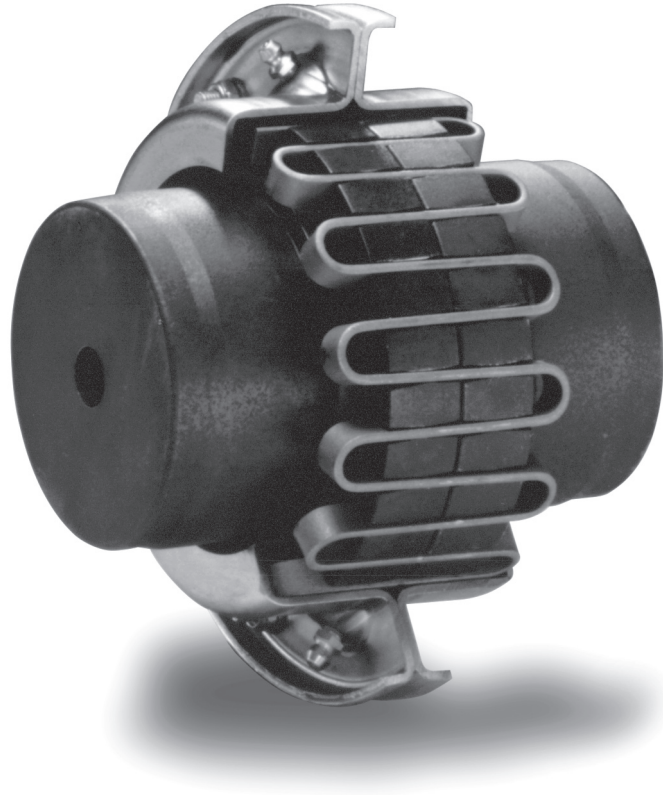

*Bibby are the world originator of the resilient grid type shaft coupling, which is universally accepted by engineers to be one of the most effective shock absorbing and de-tuning couplings in existence.*

*In addition to these vital attributes, Bibby Transmissions' resilient grid couplings can accommodate angular, parallel and axial misalignment between driving and driven shafts, whilst absorbing considerable torque overloads and smoothing cyclic variations.*

*The result is smoother running machinery, minimising downtime and protecting your investment in plant and production.*

- Fully metric
- All metal
- Torsionally resilient
- Ratings up to 32kW/rpm
- For horizontal or vertical operation.
- Low inertia pressed steel zinc passivated covers are used on couplings up to 3.8kW/rpm (Size 5430) and high grade cast iron covers are used on larger sizes.
- Standard couplings sizes 5431 - 5439 with limit end float to  $\pm 3\text{mm}$ ; sizes 5441 and 5443 to  $\pm 6\text{mm}$ . Special requirements can be provided on request.

### Recommended Fits between Shafts and Hubs

Coupling bore tolerances for sizes up to and including 5421 can be specified to suit a transition fit with shaft. In these instances, axial restraint of the hub should be provided by set screws.

For sizes above 5421 or where interference fits are preferred for smaller coupling sizes, bore tolerances should provide an interference fit between shaft and hub of 0.0002 to 0.0007mm per millimetre of diameter.

### Series S54 Spacer Couplings

- A combination of Series 54 Resilient Couplings with Bibby G Type Rigid Couplings, these units are provided with spacer shafts to B55257 and ISO3661.
- Effective shock absorption and vibration reduction - protects your investment in plant and production.
- Extremely long life - critical components operate well within their fatigue limits compared with other types of flexible coupling.
- Accommodate shaft misalignment - permits relative displacement of driving and driven machinery.
- High degree of interchangeability - minimises downtime and spares inventory.
- Exceptionally reliable - can be specified with confidence in the most demanding applications.
- Ease of maintenance - low cost grids - quickly and easily fitted.

### Spares for 54 Series Resilient Grid Couplings

Size	Grid Part No	2nd Grid unit	Seal Kit No
5411	L11AA	N/A	L5411SK
5413	L13AA	N/A	L5413SK
5415	L15AA	N/A	L5415SK
5417	L17AA	N/A	L5417SK
5419	L19AA	N/A	L5419SK
5421	L21AA	N/A	L5421SK
5423	L23AA	N/A	L5423SK
5425	L25AA	N/A	L5425SK
5427	L27AA	N/A	L5427SK
5429	L29AA	N/A	L5429SK
5430	L30IAA	L300AA	L5430SK
5431	L31IAA	L310AA	L5431SK
5433	L33IAA	L330AA	L5433SK
5435	L35IAA	L350AA	L5435SK
5437	L37IAA	L370AA	L5437SK
5439	L39IAA	L390AA	L5439SK
5441	L41IAA	L410AA	L5441SK
5443	L43IAA	L430AA	L5443SK

# Series 54

## Bibby Transmissions Resilient Couplings

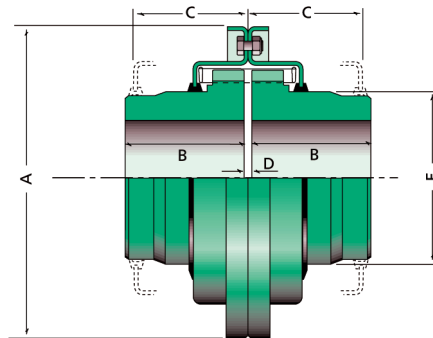

### Sizes 5411 to 5430

Coupling Size	Coupling Rating kW/rpm	Coupling Rating Nm	Dimensions in mm					Min Bore	Max Bore ①	Max Speed rpm ②	Coupling Weight (Solid Hubs) kg	MR <sup>2</sup> (Solid Hubs) kgm <sup>2</sup>
			A	B	C	D	E					
5411	0.005	48	100	50	50	1	36	10	25	6,000	1.53	0.001
5413	0.014	135	120	50	50	1	56	10	40	5,500	2.95	0.003
5415	0.024	230	145	50	50	1	80	10	56	5,000	5.29	0.007
5417	0.067	640	175	75	75	1	89	16	63	4,500	1066	0.020
5419	0.104	990	195	75	75	1	110	25	78	4,250	15.17	0.037
5421	0.187	1,790	230	90	75	1	143	25	102	3,750	27.76	0.092
5423	0.485	4,630	260	120	120	1.5	139	38	100	3,500	40.6	0.182
5425	0.746	7,120	305	120	120	1.5	184	50	130	3,250	63.7	0.433
5427	1.08	10,300	360	130	120	1.5	238	50	170	2,750	108.9	1.07
5429	2.24	21,400	425	140	150	2.5	293	75	210	2,400	195	2.45
5430	3.80	36,300	425	175	150	2.5	293	75	210	2,400	232	2.85

- ① *Maximum bores stated above are for uniformly loaded drives only, using rectangular parallel keyways to BS4235 Part 1 1972 or DIN 6885 Sheet 1 – 1968. Taper or square keys should not be used with a boss to bore ratio of less than 1.5.*
- ② *Refer to Bibby Transmissions for limited end float or special designs.*
- ③ *For repetitive high peak torque applications or selections that use SN factors less than 1.0, two keyways may be necessary—check key stress.*
- ④ *All dimensions are subject to confirmation.*

Coupling Size	Torsional Stiffness Nm/rad.
5411	2,072
5413	7,239
5415	17,160
5417	41,440
5419	75,780
5421	174,160
5423	271,860
5425	574,760
5427	1,044,800
5429	2,326,000

For Coupling Size 5430, see table on next page.

# Spacer Type - Series 54

## Bibby Transmissions Resilient Couplings

If there is no Series S54 Spacer Coupling to meet your requirements we also produce a wide range of 'standards' and specials in both resilient and gear types (including cardan units, in both brake-wheel and shear pin types, and many others). Bibby Transmissions' engineers have many years of experience in the design of such specials, and their knowledge is at your service.

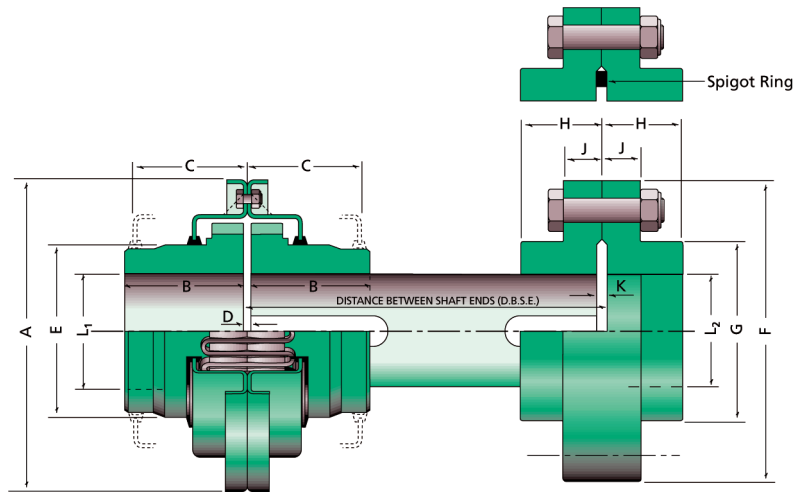

### Sizes 5411 to 5430

Coupling Size	Coupling Rating kW/rpm	Coupling Rating Nm	Dimensions in mm										Bore Sizes in mm				D.B.S.E. mm	
			A	B	C	D	E	F	G	H	J	K	Min. Bore L <sub>1</sub>	Max. Bore L <sub>2</sub>	Min. Bore L <sub>1</sub>	Max. Bore L <sub>2</sub>	Max.	Min.
S5411-10	0.005	48	100	50	50	1	36	116	84	37.5	17	5	10	14	25	60	100	95
S5413-10	0.014	135	120	50	50	1	56	116	84	37.5	17	5	10	14	40	60	140	95
S5415-15	0.024	230	145	50	50	1	80	152	107	49.5	20	5	10	20	56	80	180	105
S5417-15	0.067	640	175	75	75	1	89	152	107	49.5	20	5	16	20	63	80	200	130
S5419-20	0.104	990	195	75	75	1	110	178	130	60.5	20	5	25	27	78	90	200	140
S5421-25	0.187	1,790	230	90	75	1	143	213	157	76.5	22	5	25	33	102	110	200	175
S5423-25	0.485	4,630	260	120	120	1.5	139	213	157	76.5	22	5	38	33	100	110	300	205
S5425-30	0.746	7,120	305	120	120	1.5	184	240	182	89.5	22	5	50	39	130	130	350	220
S5427-40	1.08	10,300	360	130	120	1.5	238	318	250	118	29	10	50	52	170	180	380	260
S5429-50	2.24	21,400	425	140	150	2.5	293	389	309	151	38	10	75	71	210	220	400	315
S5430-50	3.80	36,300	425	175	150	2.5	293	389	309	151	38	10	75	71	210	220	450	350

- ① *Maximum bores stated above are for uniformly loaded drives only using rectangular parallel keyways to BS4235 Part 1 1972 or DIN6885 Sheet 1 – 1968. Taper or square keys should not be used with a boss to bore ratio of less than 1.5.*
- ② *Refer to Bibby Transmissions for details of maximum speeds.*
- ③ *For repetitive high peak torque applications or selections that use SN factors less than 1.0, two keyways may be necessary – check key stress.*
- ④ *All dimensions are subject to confirmation.*

# Series 54

## Bibby Transmissions Resilient Couplings

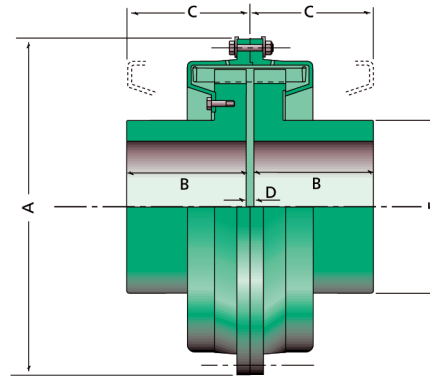

### Sizes 5431 to 5443

Coupling Size	Coupling Rating kW/rpm	Coupling Rating Nm	Dimensions in mm					Min Bore	Max Bore ①	Max Speed rpm ②	Coupling Weight (Solid Hubs) kg	MR <sup>2</sup> (Solid Hubs) kgm <sup>2</sup>
			A	B	C	D	E					
5431	5.4	51.6	530	200	196	3	265	105	190	1,450	287	5.99
5433	7.1	67.8	590	215	218	3	300	105	215	1,300	385	10.12
5435	9.8	93.6	640	240	228	3	330	130	235	1,200	510	15.46
5437	13.1	125	680	260	228	3	370	130	265	1,100	662	22.77
5439	17.8	170	780	280	248	3	415	155	295	980	906	40.52
5441	23.7	226	870	305	302	6	455	155	325	860	1,282	75.93
5443	32.0	306	1,010	325	302	6	580	175	415	740	1,970	157.14

- ① **Maximum bores stated above are for uniformly loaded drives only using rectangular parallel keyways to BS4235 Part 1 1972 or DIN 6885 Sheet 1-1968. Taper or square keys should not be used with a boss to bore ratio of less than 1.5.**
- ② **Refer to Bibby Transmissions for speeds higher than those shown and for limited end float or special designs.**
- ③ **For repetitive high peak torque applications or selections that use SN factors less than 1.0, two keyways may be necessary—check key stress.**
- ④ **All dimensions are subject to confirmation.**

Coupling Size	5430	5431	5433	5435	5437	5439	5441	5443
Basic Rating kW/rev	3.8	5.4	7.1	9.8	13.1	17.8	23.7	32.0
Torsional Stiffness MNm/rad	0.25 x Basic	1.75	1.98	3.42	4.33	5.90	10.11	13.14
	0.5 x Basic	5.5	9.37	17.65	21.26	31.26	54.81	48.95
	0.75 x Basic	13.95	28.64	57.76	68.11	103.01	172.20	132.42
	1 x Basic	34.5	71.6	135.54	207.87	250.09	361.50	299.46
	Basic/0.68	88.9	189.5	332.21	458.54	799.18	999.05	978.47
Basic Rating kNm	36	51.6	67.8	93.6	125	170	226	306

Speed Factors					
Speed Factors (SN)					
rpm	k	rpm	k	rpm	k
up to 100	0.68	450	0.93	1000	1.09
150	0.74	500	0.95	1100	1.11
200	0.79	600	0.98	1200	1.13
250	0.83	700	1.02	1300	1.14
300	0.86	750	1.03	1400	1.16
400	0.91	900	1.07	1600 +	1.20

# Coupling Selection Procedure

## Information Required

- Type of Prime Mover
- Kilowatt (kW) or Torque Rating
- Rotational speed rpm
- What application the coupling is to be used on
- Type of duty (eg. reversing or unidirectional, frequency of starts and peak torques)
- Diameter of drive and driven shafts
- Any limitation of axial travel
- Any other physical limitations
- Any other specific needs

**Note: Where high peak loads can occur and for brake applications please contact Bibby Transmissions.**







- The system peak torque is the maximum load created by the driving or driven equipment.
- Occasional peak torques of twice the catalogue rating can be accommodated providing they occur less than 1000 times during the life of the coupling.
- For drives where the operation is near or actually passes through a major torsional natural frequency, a mass elastic analysis of the system is advised. When the Service Factor in Table 1 is greater than 2 consult your supplier or Bibby Transmissions.

**Table 2**

Number of Cylinders	Service Factor
6 and over	0.5 + S.F. Table 1
4 or less	1.0 + S.F. Table 1
Less than 4 Refer to Bibby Transmissions	

**Table 1 – Service Factors**

Complimentary to customers specialist knowledge of their own equipment

Torque Demands Driven Machine	Typical applications for electric motor or turbine driven equipment	Typical Service Factor
	Constant Torque such as Centrifugal Pumps, Blowers and Compressors	1
	Continuous duty with some torque variations including Extruders, Forced Draft Fans	1.5
	Light shock loads such as Briquetting Machine, Rubber Calendar or Crane and Hoist	2
	Moderate shock loading as expected from a Car Dumper, Ball Mill or Vibrating Screen	2.5
	Heavy shock load with some negative torques from Crushers, Hammer Mill and Barking Drum	3
	Applications like Reciprocating Compressors with frequent torque reversals, which do not necessarily cause reverse rotations	Consult Bibby Transmissions

**Table 3**

Maximum Coupling Bore Sizes		
Duty Class	Load Classification	Max. Bore Size
Uniform	Steady load, soft start, very rarely subjected to maximum loading	Catalogue Maximum Bore
Medium	Steady load with superimposed cyclic load fluctuations	<u>Boss Diameter</u> 1.45
Heavy	Repeated maximum load fluctuations/ shock loads	<u>Boss Diameter</u> 1.5
Extra Heavy	Regularly subjected to fully reversing maximum loads	<u>Boss Diameter</u> 1.6

## Bibby Coupling Selection (If in doubt please consult your supplier)

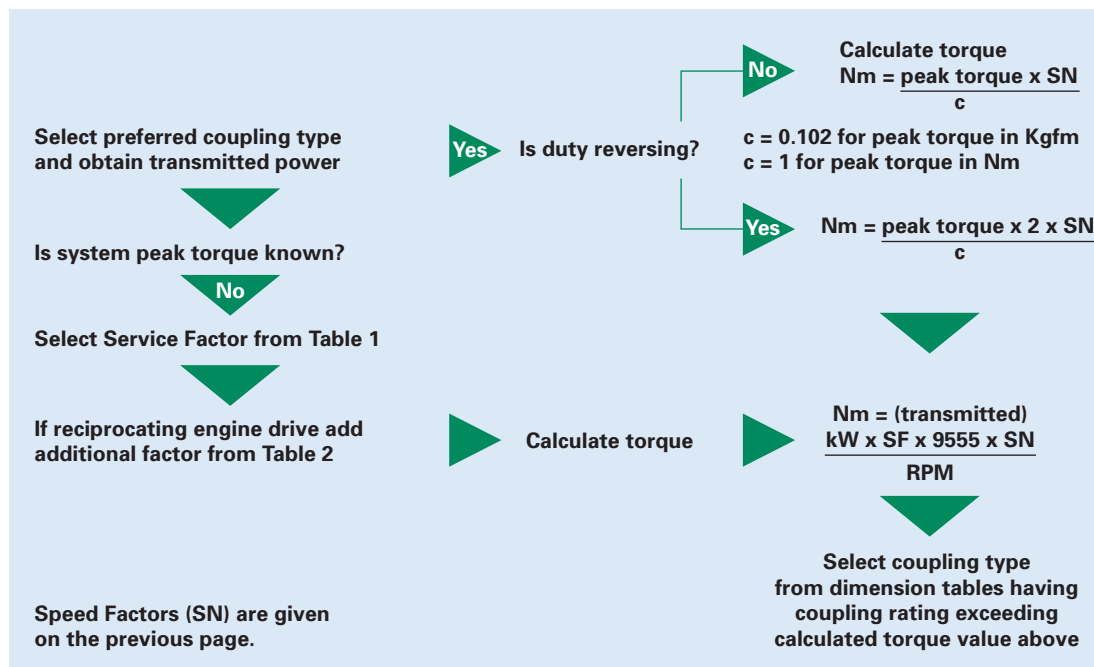

## Having selected the coupling type and size, now check the following.

- that the coupling running speed is lower than the permitted maximum.
- that the shaft spacing and coupling dimensions can be accommodated.
- that the maximum bore is suitable for the shaft. (If not, go to next size above and check again).
- acceptability of key stresses and boss strength for your specific duty. Refer to Table 3.