

Service and Meter Requirements

2021 Edition

Summary of Changes in This Edition

Number	Change
--------	--------

2021-03-26 Update

C9141	New standard created to provide requirements on modular current transformer compartments which house the ComEd CTs in customer gear.
--------------	--

INDEX

SERVICE AND METER REQUIREMENTS

SERVICE, GENERALLY

General requirements	C7800
Phase arrangement	C7802

SERVICE, OVERHEAD

Single-phase, 400 A and below	C7820
Row house service	C7825
Three-phase, 200 A and below	C7830
Three-phase, over 200 A	C7840
Box-type service head	C7850
Recessed service head	C7852
Service to meter pole	C7860
Service to trailer park pole	C7870
Service extension on Company pole	C7815
CATV/communications supplies	C7977
Street light syst's and traffic sig'ls	C7973

SERVICE, UNDERGROUND

Cable pole	C7951
Connection to overhead ESS	C7952
CATV/communications supplies	C7978
Street light syst's and traffic sig'ls	C7974

SERVICE, TEMPORARY

Outdoor, to pole	C7885
Underground	C7890

LIGHTING

Customer-owned outdoor light	C7960
------------------------------------	-------

METERING, GENERALLY

General requirements	C9110
General information	C9111
High-rise Comm requirements	C9114

METERING, 1-PHASE, SELF-CONTAINED

Overhead, to 200 A	C9120
Overhead, 320 A	C9121
Overhead, 200 A, multi-position	C9122
Underground, to 200 A	C9125
Underground, 320 A	C9126
Underground, 200 A, multi-position	C9127

METERING, 3-PHASE, SELF-CONTAINED

Overhead, to 200 A	C9130
Overhead, 200 A, multi-position	C9132
Underground, to 200 A	C9135
Underground, 200 A, multi-position	C9137
Multi-position, 200 A, ovhd./undg.	C9134

METERING, TRANSFORMER RATED

(480 V and below)	
Current transformer compartment	C9140
Modular CT compartment	C9141
Meter, 1-phase	C9145
Meter, 3-phase	C9150

(Above 480 V)	
SCADA metering	C9162

This page intentionally left blank

PREFACE

This book is issued by Commonwealth Edison Company (herein called the “Company”) as a reference and guide to its regulations, specifications, and practices for the connection and supply of electric service. It is intended for the use of customers, architects, engineers, contractors, electricians, and other persons engaged in the planning or construction of buildings, or the installing or replacing of equipment that is to be connected to and served from the Company’s electric distribution system.

The term “Customer” as used herein includes a contractor, agent, or other representative acting for the Customer, or the owner of the premises. Each requirement for specific equipment, facilities, or work to be done in connection with providing electric service to the Customer shall be the Customer’s responsibility unless otherwise stated.

The information and specifications contained herein supplement the Company’s rate schedule on file with the Illinois Commerce Commission, which set forth the general conditions under which electric service will be supplied. In the event a condition arises that is not specifically covered herein, consult the Company to determine the applicable requirements. In case of a conflict between this book and the filed rate schedule, the rate schedule governs. A copy of the Company’s rate schedule currently in effect, along with proposed revisions thereto, is posted on the Company’s Web site at <https://www.comed.com/customer-service/rates-pricing/rates-information/Pages/current-rates.aspx>

The specifications contained in this book come into effect on the dates shown in each, and are permitted to be used for any construction begun on or after that date. All prior specifications that conflict with the specifications in this book cease to be effective on January 1, 2017, and work done to those specifications (including all specifications contained in the *Information and Requirements for the Supply of Electric Service*, or “Silver Book”) on or after that date will not be accepted for connection of new or revised service.

Information and Advice

The Company has representatives who will meet with the Customer and discuss any problem that may arise concerning the installation or use of electric service. Information and advice on the most efficient and reliable plan of service is also available upon request.

It is recommended that the Customer consult with the Company well in advance of installing or modifying service. A minimum of two weeks’ advance notice is requested for connecting overhead service drops; at least twelve weeks may be needed for larger or more complex installations.

Compliance to Codes

The Company’s filed Terms and Conditions require that all electrical facilities, wiring, and equipment furnished by the Customer be and remain in compliance with the National Electrical Code. Other local codes may apply, in which case the Customer’s facilities must comply with the most stringent applicable rules.

It is the Customer’s responsibility to obtain any necessary permits for installation of wiring or equipment on the premises, along with any required inspections of the installation. The Company is usually prohibited by municipal authorities from connecting service to any installation that has not passed inspection. Contracts for the electrical installation should include the requirement that all electrical wiring and apparatus conform with the requirements of applicable governmental codes, as well as the standards of the National Fire Protection Association.

Inspections performed by the Company are intended to assess compliance with the Company’s rules and standards, and are not evidence of compliance with National Electrical Code or other governing codes or regulations.

Organization

The specifications in this book are presented as numbered standards. Each standard applies to a different type of installation, and they are not interchangeable. All of the items shown on a given standard are necessary to an acceptable installation.

Each standard is numbered in both upper corners with a C-number (such as "C7800"), which may also be used in communications or agreements with the Company to specify the facilities required for a particular installation. Below the C-number is a revision date, showing the date the standard was last revised.

Revisions

Revisions are identified by revision arrows (◀). An arrow pointing to the C-number indicates an extensive revision, and the entire standard should be reviewed. A listing of standards revised and their specific revisions are provided in a Memorandum in the front of this book.

Notes

The notes contained in the standards are arranged in five groups:

- **Application** notes specify how or why a standard is used. They are intended to clarify usage.
- **Reliability** notes indicate items that, if improperly installed or misapplied, could lower the quality of service. Reliability notes, where referenced on the drawings, are marked with a diamond to highlight them.
- **Supplementary Material** notes contain information on variations to the standard and require an addition or omission of material where applicable.
- **Information** notes supply information such as deviations in spacing or location of equipment and references to other standards for methods of installing supplied material.
- **Operations** notes denote recommended construction procedures. Notes in parentheses are referenced on drawings.

Each note is numbered for identification. Circled notes are referenced where they apply on the drawings or in the material table. Uncircled notes apply to the standard generally.

Service Ordering

To order new service installation, or to change or remove service facilities, call ComEd's New Business hotline at (866) NEW-ELEC (866-639-3532). Please have the street address, contact information, and details about the proposed work available when you call.

To request changes to an existing service, such as to start or stop service at an existing address, or to move an account to a new address, call ComEd's Customer Service Center at (800) EDISON-1 (800-334-7661) for residential accounts, or (877) 4-ComEd-1 (877-426-6331) for business accounts.

You can also submit service requests through ComEd's Web site at <https://www.comed.com/MyAccount/MyService/Pages/ServiceRequests.aspx>

CONTACTING THE COMPANY

IN AN EMERGENCY—To report an emergency involving power lines

First: Call your local emergency services, if appropriate:

9-1-1 or local number: _____

Then: Call ComEd:

(800) EDISON-1 (800-334-7661)

Emergency assistance is available 24 hours a day. Tell the operator your exact address and contact information, and if anyone has been hurt or trapped. Keep everyone far away from downed wires or damaged equipment until help arrives, no matter how safe it looks.

Service Installation or Changes

New Business Hotline:(866) NEW-ELEC

Start, Stop, or Move Service

Residential: (800) EDISON-1

Business:(877) 4-COMED-1

Underground Facility Location—Call Before You Dig

Outside Chicago: JULIE.....8-1-1
or(800) 892-0123

Inside Chicago: DIGGER(312) 744-7000

Other Requests

Including requests for line voltages, rubber-up, landscaping repairs, etc.

Residential: (800) EDISON-1

Business:(877) 4-COMED-1

TDD/TTY:(800) 747-0593

Online

Service Requests: <https://www.comed.com/MyAccount/MyService/Pages/ServiceRequests.aspx>

Mail

ComEd Customer Care Center
P.O. Box 87522
Chicago, IL 60680-5379

Do you have suggestions for this book?

In the interest of improving future editions, you are invited to submit suggestions for new installation standards or changes to existing standards. Write:

Service and Meter Book
Distribution Standards Dept.
ComEd
2 Lincoln Centre, 5th Floor
Oakbrook Terrace, IL 60181-4295

Give the C-number to which your suggestion applies, along with any supporting details, sketches, diagrams, or examples. Suggestions will not normally be answered individually, but if deemed appropriate, will be incorporated into subsequent editions of this book. Please do not send payments or inquiries about customer accounts to this address, as they cannot be processed there.

GENERAL SERVICE REQUIREMENTS

480V AND BELOW SYSTEMS

NOTES:

APPLICATION

- THIS STANDARD SHALL BE USED TO SPECIFY GENERAL REQUIREMENTS FOR SECONDARY SERVICE CONNECTIONS.

GENERAL

IN ORDER THAT A CUSTOMER REQUIRING ELECTRIC SERVICE MAY PURCHASE APPROPRIATE SERVICE ENTRANCE EQUIPMENT, AND WIRE THE CUSTOMER'S SERVICE ENTRANCE EQUIPMENT PROPERLY, THE INTERRUPTING CAPACITY REQUIRED TO INTERRUPT THE MAXIMUM SUPPLY CAPACITY PLANNED BY THE COMPANY FOR THE LOCATION SHOULD BE TAKEN INTO ACCOUNT. THIS INFORMATION WILL BE FURNISHED BY THE COMPANY UPON REQUEST.

IF THE CUSTOMER REQUIRES THREE-PHASE, THREE-WIRE SERVICE, THE SERVICE EQUIPMENT AND ITS WIRING WILL VARY DEPENDING ON WHETHER OR NOT (A) THE SUPPLY IS TO BE UNGROUNDED (480V ONLY), OR (B) ONE OF THE PHASES IS TO BE GROUNDED. IF A GROUNDED CONDUCTOR IS TO BE INCLUDED IN THE SECONDARY SERVICE CONNECTION IN ACCORDANCE WITH THE REQUIREMENTS OF THE NATIONAL ELECTRIC CODE, THE CONNECTION WILL BE CONSIDERED A THREE-PHASE, FOUR-WIRE SERVICE.

THE TOTAL RATED CAPACITY OF ALL DISCONNECTING MEANS SUPPLIED THROUGH A SINGLE OR PARALLEL SERVICE CONNECTION OF 480 VOLTS OR LESS SHALL NOT EXCEED 4,000 AMPERES.

THE "SERVICE POINT," AS INDICATED ON THE SPECIFICATIONS FOR SERVICE CONNECTIONS, IS THE POINT OF DEMARCATION BETWEEN THE COMPANY'S SYSTEM AND THE CUSTOMER'S PREMISE WIRING. IN GENERAL, FACILITIES LINEWARD OF THIS POINT ARE MAINTAINED BY THE COMPANY, AND FACILITIES LOADWARD OF THIS POINT (EXCEPT METERING EQUIPMENT SUPPLIED AND MAINTAINED BY THE COMPANY) ARE MAINTAINED BY THE CUSTOMER.

VOLTAGE TOLERANCE

THE COMPANY DESIGNS AND OPERATES ITS SYSTEM SO THAT, UNDER NORMAL CONDITIONS, THE MAXIMUM MOMENTARY VOLTAGE DIP EXPERIENCED BY ANY CUSTOMER WILL NOT EXCEED 9 VOLTS ON A 120 VOLT BASIS AT A FREQUENCY OF 5 PER DAY OR LESS. THE TOLERANCE FOR MORE FREQUENT DISTURBANCES IS LOWER. CONTACT THE COMPANY FOR MORE INFORMATION. THE CUSTOMER SHALL PROVIDE INFORMATION ABOUT ITS MOTOR LOADS, AND OTHER LARGE TRANSIENT LOADS, SO THAT THE COMPANY CAN IDENTIFY AND PREVENT INTERFERENCE WITH SERVICE TO OTHER CUSTOMERS.

VOLTAGE DIPS EXCEEDING 60% MAY OCCASIONALLY OCCUR AS A RESULT OF ABNORMAL OPERATIONS. CUSTOMERS WITH SENSITIVE EQUIPMENT SHOULD TAKE MEASURES TO PREVENT THESE DIPS FROM INTERRUPTING OR INTERFERING WITH THEIR OPERATIONS.

OVERHEAD SERVICE

IN ORDER THAT WORK DONE BY THE COMPANY AND THE CUSTOMER BE PROPERLY COORDINATED AND THAT PROPER CLEARANCES BE MAINTAINED, THE CUSTOMER SHALL CONSULT THE COMPANY ABOUT THE LOCATION OF THE COMPANY POLE TO WHICH THE SERVICE DROP WILL BE FASTENED AND THE HEIGHT AT WHICH THE SERVICE ATTACHMENT MUST BE PLACED ON THE BUILDING TO ENSURE PROPER CLEARANCES.

IF THE SERVICE HEAD IS LOCATED WITHIN FOUR FEET OF A COMPANY POLE, NO SERVICE ATTACHMENT IS REQUIRED AND THE COMPANY WILL ATTACH THE SERVICE DROP WIRES DIRECTLY TO THE SERVICE ENTRANCE WIRES.

WHERE FINISHING IS CONTEMPLATED ON THE INSIDE OF THE WALL ON WHICH THE SERVICE ATTACHMENT IS MOUNTED, THE WASHERS OR PLATES, AND THE NUTS OR BOLT HEADS WHICH SECURE THE ATTACHMENT, SHOULD BE COUNTERSUNK INTO THE WALL OR STUDDING AND ANY PROTRUDING BOLT ENDS CUT OFF FLUSH WITH THE NUTS. IF COUNTERSINKING IS IMPRACTICAL, THE METAL PARTS ON THE INSIDE OF THE WALL SHOULD BE INSULATED.

THE SERVICE ATTACHMENT SHOULD BE LOCATED AND INSTALLED IN SUCH A WAY AS TO BE CAPABLE OF WITHSTANDING A TENSION OF 1,000 POUNDS WITHOUT DAMAGE TO THE STRUCTURE. OVER-LENGTH SERVICES MAY IMPOSE GREATER LOADS ON THE ATTACHMENT; CONSULT THE COMPANY FOR FURTHER INFORMATION.

ALLOWABLE LENGTH OF SERVICE DROP:

SERVICE ENTRANCE CAPACITY	ALLOWABLE LENGTH
SINGLE-PHASE, 200A OR LESS	150 FT RESIDENTIAL 135 FT NON-RESIDENTIAL
SINGLE-PHASE, OVER 200A TO 400A	110FT
SINGLE-PHASE, OVER 400A	CONSULT COMPANY
THREE-PHASE, 200A OR LESS	100FT
THREE-PHASE, OVER 400A	CONSULT COMPANY

UNDERGROUND SERVICERESIDENTIAL:

IF THE COMPANY INSTALLS AN UNDERGROUND SECONDARY SERVICE CONNECTION, AND THE LENGTH OF THE SERVICE CONNECTION IS 100 FEET OR LESS, THE SIZE OF CABLE FOR A SINGLE-FAMILY RESIDENCE WILL BE BASED ON THE CUSTOMER'S SERVICE ENTRANCE CAPACITY. THE FOLLOWING TABLE LISTS STANDARD CABLES AND THE APPROPRIATE METER CONNECTION DEVICE.

SERVICE ENTRANCE CAPACITY	STANDARD CABLE SIZE (BURIED)	STANDARD CABLE SIZE (IN CONDUIT)	METER CONNECTION DEVICE
100A OR 200A	2-#2/0 (AL) & 1-#1 (AL)	2-#4/0 (AL) & 1-2/0 (AL)	200A
400A (80%)	2-350 kcmil. (AL) & 1-#4/0 (AL)	3-250 kcmil. (CU)	320A

ACAD

RESIDENTIAL (CONTINUED):

IF THE SERVICE CONNECTION LENGTH IS GREATER THAN 100 FEET, THE COMPANY WILL DETERMINE IF SECONDARY SERVICE IS PRACTICAL. IF SO, VOLTAGE DROP CONSIDERATIONS MAY REQUIRE THE USE OF A LARGER SIZE OF CABLE THAN THAT SHOWN IN THE TABLE FOR THE SERVICE ENTRANCE CAPACITY. IN SUCH CASE, THE COMPANY WILL INFORM THE CUSTOMER OF THE CABLE SIZE PROVIDED. THE CUSTOMER WILL PROVIDE A METER CONNECTION DEVICE WITH TERMINALS OF A SIZE ADEQUATE TO ACCOMMODATE THE CABLE.

IN THE CASE OF AN APARTMENT BUILDING WITH LESS THAN 4 UNITS, THE COMPANY WILL INFORM THE CUSTOMER OF THE CABLE SIZE NECESSARY AND THE TYPE OF METER CONNECTION DEVICE TO BE PROVIDED FOR TERMINATION OF THE SERVICE CONNECTION. THE METER CONNECTION DEVICE AND CABLE MUST BE FURNISHED AND INSTALLED IN ACCORDANCE WITH THE REQUIREMENTS OF THE COMPANY'S STANDARD SPECIFICATIONS AND PREVAILING LOCAL CODE (OR NATIONAL ELECTRIC CODE, IF THERE IS NO PREVAILING LOCAL CODE).

IF AN UNDERGROUND SECONDARY SERVICE CONNECTION IS NOT DEEMED TO BE PRACTICABLE, A RESIDENTIAL SERVICE STATION WILL BE REQUIRED.

- ▶ ALL NEW RESIDENTIAL UNDERGROUND SECONDARY SERVICES, OVERHEAD-TO-UNDERGROUND RELOCATED SERVICES, AND UNDERGROUND-TO-UNDERGROUND RELOCATED SERVICES FED FROM COMPANY EQUIPMENT LOCATED IN THE DEFINED REAR LOT(S) OF SAID DEVELOPMENT ARE TO BE INSTALLED IN PVC PIPE, 3" MINIMUM (OR AS DETERMINED BY COMPANY DESIGN ENGINEER), SCHEDULE 40 OR PER LOCAL CODE. A MAXIMUM OF THREE-36" MINIMUM RADIUS BENDS ARE ALLOWED IN THE PIPE RUN (INCLUDING BENDS AT METER RACEWAY AND COMPANY EQUIPMENT). CONDUIT SHALL BE BURIED 24" MINIMUM COVER TO TOP OF DUCT OR PER LOCAL CODE. COMPANY DESIGN ENGINEER TO DETERMINE FINAL QUANTITY, SIZE, AND PATH OF CONDUIT FOR EACH SPECIFIC PROJECT.

NON-RESIDENTIAL:

IF THE COMPANY INSTALLS AN UNDERGROUND SERVICE CONNECTION, THE SIZE OF CABLE FURNISHED AS STANDARD FACILITIES WILL NORMALLY BE BASED ON THE CUSTOMER'S EXPECTED DEMAND. THE COMPANY WILL INFORM THE CUSTOMER OF THE CABLE SIZE PROVIDED AND THE TYPE OF METER CONNECTION DEVICE TO BE PROVIDED FOR TERMINATION OF THE SERVICE CONNECTION.

WHERE THE COMPANY INSTALLS DUCT FOR AN UNDERGROUND SERVICE CONNECTION, THE COMPANY NORMALLY WILL SIZE THE DUCT INSTALLATION FOR THE CUSTOMER'S SERVICE ENTRANCE CAPACITY.

IF THE CUSTOMER INSTALLS AN UNDERGROUND SERVICE CONNECTION, CONTAINING MORE THAN ONE SET OF CABLES, TO THE COMPANY'S OVERHEAD DISTRIBUTION SYSTEM, THE COMPANY MAY REQUIRE THAT THE CABLES TERMINATE AT A SERVICE PEDESTAL, AND WILL FURNISH THE PEDESTAL AND THE DISTRIBUTION FACILITIES FROM IT TO THE POLE.

UNDER NO CIRCUMSTANCE WILL THE COMPANY CONNECT MORE THAN FOUR SETS OF SERVICE CABLES TO A SINGLE POLE OR PEDESTAL. AN ELECTRIC SERVICE STATION WILL BE REQUIRED IN SUCH CASES.

This page intentionally left blank

SERVICE PHASE ARRANGEMENT

APPLICATION:

THIS STANDARD SHALL BE USED TO SPECIFY THE STANDARD ARRANGEMENT AND PHASING OF SERVICE CONNECTIONS.

NOTES:

INFORMATION:

1. STANDARD PHASE DESIGNATIONS AT ComEd ARE AS FOLLOWS:
 - a. ON 120/240V SERVICE, THE PHASES ARE DESIGNATED X,Y,Z.
 X IS NORMALLY THE LEADING PHASE OF THE LIGHTING SERVICE.
 Y IS NORMALLY THE LAGGING PHASE OF THE LIGHTING SERVICE.
 Z IS ALWAYS THE HIGH PHASE (208V TO NEUTRAL) OF A THREE-PHASE SERVICE.
 - b. ON SINGLE PHASE 120/208V SERVICE, THE PHASES ARE DESIGNATED A,B.
 - c. ON ALL OTHER SERVICES, THE PHASES ARE DESIGNATED A,B,C.

2. STANDARD PHASE ROTATION IS A-B-C OR X-Y-Z. IN SOME AREAS OF THE ComEd TERRITORY, THE STANDARD PHASE ROTATION IS REVERSED (C-B-A OR Z-Y-X). THE CUSTOMER SHOULD CONFIRM THE PHASE ROTATION OF THE COMPANY SOURCE, WHEN ORDERING SERVICE.

3. THE CUSTOMER SHALL DURABLY AND LEGIBLY MARK ALL SERVICE ENTRANCE CONDUCTORS TO INDICATE PHASING. THE RECOMMENDED COLOR CODE FOR INDICATING PHASING IS SHOWN IN THE FOLLOWING TABLE.

SERVICE VOLTAGE	A OR X	B OR Y	C OR Z	NEUTRAL
208Y/120V	BLACK	RED	BLUE	WHITE
120/240V	BLACK	RED	ORANGE *	WHITE
480Y/277V OR 480V (3 WIRE)	BROWN	PURPLE †	YELLOW	GRAY
ANY VOLTAGE (ALTERNATE METHOD)	1 BAND	2 BANDS	3 BANDS	4 BANDS

▶ * PER NESC ARTICLE 110.15

▶ † ORANGE MAY ALSO BE USED IN THIS POSITION

4. WHERE A DIFFERENT PHASE MARKING SYSTEM IS IN USE, THE CUSTOMER SHALL NOTIFY ComEd's INSTALLER BEFORE SERVICE IS CONNECTED.

This page intentionally left blank

SERVICE DROP-DOWN POLE

NOTES:

APPLICATION:

- THIS STANDARD DESCRIBES THE REQUIREMENTS WHEN AN OVERHEAD SUPPLY IS REQUIRED, BUT THE ComEd POLE IS SO CLOSE TO THE BUILDING THAT A SERVICE DROP EXTENDED FROM A CROSSARM OR SECONDARY BRACKET IS IMPRACTICAL.

INFORMATION:

1 CUSTOMER FURNISHES, INSTALLS AND MAINTAINS THE FOLLOWING EQUIPMENT (SEE FIGURE 1):

- A - SERVICE HEAD. ALL NEW SERVICE HEADS SHALL BE LOCATED AS SHOWN IN FIGURE 1, AND MUST BE POSITIONED SO THAT THE SERVICE WIRE INSTALLATION HAS SAFE ACCESS FROM AN EXTENSION LADDER.
- B - SERVICE RUN
- C - SERVICE RUN WIRES (ALLOW SUFFICIENT WIRE TO MAKE CONNECTION TO ComEd SERVICE DROP WIRES). CUSTOMER TO NOTIFY ComEd OF SIZE OF SERVICE RUN WIRES.

D - INSULATED CLEVIS AND BOLT OR SCREW ON 8 INCH CENTERS FOR EACH SERVICE DROP WIRE. (NOT REQUIRED IF SERVICE HEAD IS WITHIN 4 FEET OF THE POLE.)

2 ComEd FURNISHES, INSTALLS AND MAINTAINS THE FOLLOWING EQUIPMENT:

- E - SERVICE DROP
- F - CONNECTORS FOR CONNECTING CUSTOMER WIRES TO SERVICE DROP.

3 THE BUILDING ATTACHMENT (ITEM "D") OR THE SERVICE CONNECTORS (ITEM "F") MUST BE LOCATED TO PROVIDE A MINIMUM HORIZONTAL CLEARANCE OF 3 FEET TO THE SURFACE OF THE POLE.

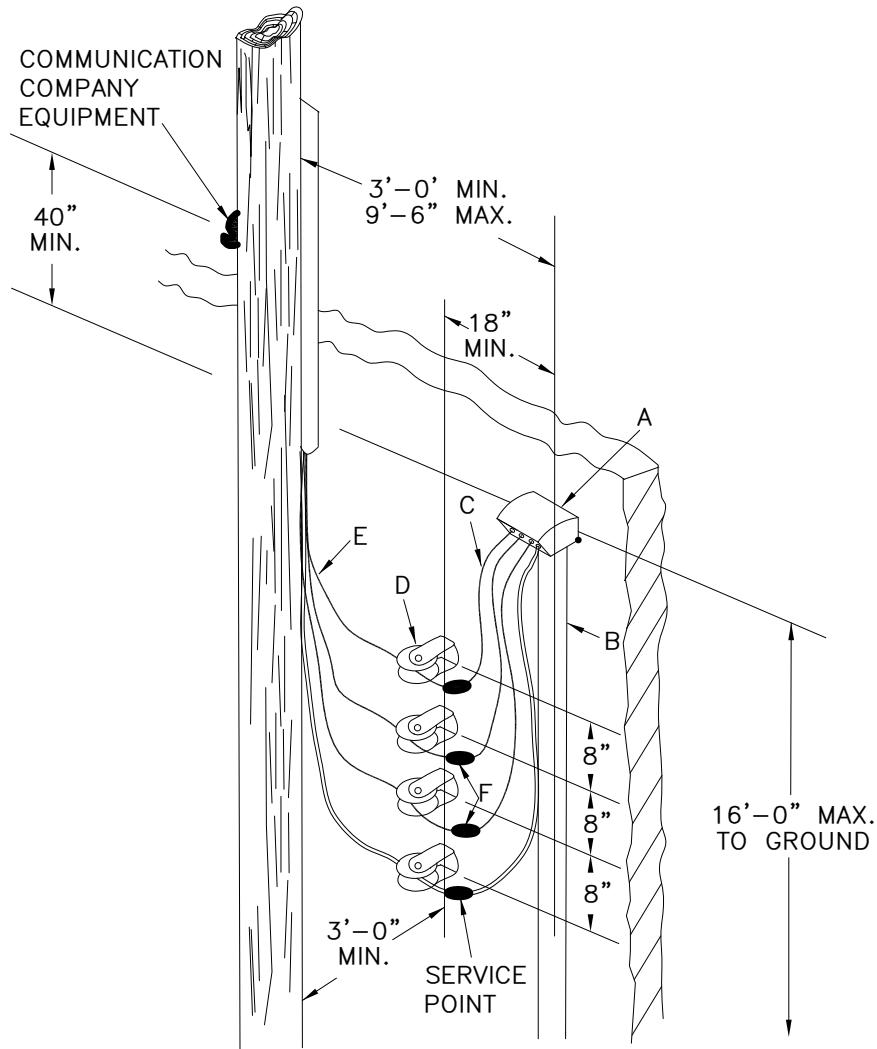

FIGURE-1

This page intentionally left blank

SINGLE PHASE SERVICE ATTACHMENT

UP TO 400 AMPS

NOTES:

APPLICATION:

- THIS STANDARD DESCRIBES THE REQUIREMENTS FOR THE ATTACHMENT OF SINGLE PHASE SERVICES OF UP TO 400 AMPS TO A: MASONRY WALL (FIGURE-1), BRICK VENEER WALL (FIGURE-2), FRAME OR STUCCO WALL (FIGURE-3), PORCH POST (FIGURE-4), WOOD RISER (FIGURE-5), STEEL CONDUIT RISER (FIGURE-6) OR ROOF PLATE INSTALLATION (FIGURE-7).

INFORMATION:

- 1 CUSTOMER OWNS AND INSTALLS THE EQUIPMENT AS SPECIFIED IN THE APPROPRIATE FIGURE:

A – ROOF PLATE. TO BE AT LEAST #10 GAUGE SHEET STEEL, AND BOLTS TO BE AT LEAST 1/4". ROOF PLATES OF TYPE A OR TYPE B ARE ACCEPTABLE.

TYPE A—INSTALL FOUR CARRIAGE BOLTS THROUGH RAFTERS WITH WASHERS AND NUTS ON THE UNDERSIDE OF THE RAFTERS. WHEN PLATES ARE INSTALLED ON RAFTER SPACING OTHER THAN 16", INSTALL A 2x6 BOARD UNDER TWO RAFTERS. AS AN ALTERNATIVE FOR CARRIAGE BOLTS WHERE THE ROOF PLATE IS SO LOCATED THAT THE FASTENING OF NUTS TO SUCH BOLTS IS IMPRACTICABLE, THE USE OF FOUR 3-1/2" X 1/4" LAG SCREWS WILL BE PERMITTED. THE LAG SCREWS SHALL BE SCREWED, NOT HAMMERED, INTO DRILLED HOLES 3/16" DIAMETER AND 2" DEEP.

TYPE B—INSTALL TWO CARRIAGE BOLTS ON EACH SIDE OF RAFTER WITH NUTS AND SMALL PLATE ON UNDERSIDE OF RAFTER.

B – SERVICE HEAD. ALL NEW SERVICE HEADS SHALL BE LOCATED NO MORE THAN 25' ABOVE THE GROUND AND MUST BE POSITIONED SO THAT THE SERVICE WIRE INSTALLATION HAS SAFE ACCESS FROM AN EXTENSION LADDER.

C – SERVICE RUN.

D – SERVICE RUN WIRES. CUSTOMER SHOULD ALLOW A MINIMUM OF 18" BEYOND THE SERVICE HEAD TO MAKE CONNECTIONS TO SERVICE DROP WIRES.

E – SERVICE ATTACHMENT – FORKBOLT WITH NUTS AND WASHERS OR EYEPLATE.

F – METAL FLASHING SEALED WITH MASTIC IS REQUIRED WHERE SERVICE RUN EXTENDS THROUGH ROOF.

G – 2X4 BLOCKING SOLIDLY INSTALLED BETWEEN RAFTERS IS REQUIRED WHERE RISER EXTENDS THROUGH ROOF.

H – 5/8" GALVANIZED MOUNTING BOLTS (WITH NUTS) INSTALLED IN CENTER LINE OF STUDDING. OMIT MIDDLE BOLT FOR A 4X4 RISER INSTALLATION.

J – 4X4 OR 6X6 RISER OF PRESERVATIVE TREATED YELLOW PINE, OR EQUALLY STRONG AND DURABLE WOOD.

K – 2-1/4" GALVANIZED SQUARE WASHER.

L – GALVANIZED IRON 1/8" X 1" X 12" PORCH BRACE WITH FOUR 5/16" HOLES, ONE TO BE INSTALLED ON EACH SIDE. USE 1/4" X 2-1/2" GALVANIZED LAG SCREWS.

INFORMATION (CONTINUED):

- M – RIGID STEEL CONDUIT – 2-1/2" FOR 100 AMPERE OR SMALLER, OR 3" FOR LARGER SERVICE ENTRANCE EQUIPMENT, OR METALLIC RACEWAY OF EQUIVALENT STRENGTH MAY BE USED.
- N – MOUNTING CLAMP WITH 1/2" BOLTS, NUTS, AND WASHERS. FOR FRAME, STUCCO, OR BRICK VENEER, INSTALL BOLTS IN CENTER LINE OF STUDDING OR, IN THE CASE OF TWO BOLT STRAP ATTACHMENT, STRADDLING A STUD WITH AN ANCHOR PLATE BRIDGING STUD.
- P – METER CONNECTION DEVICE ADAPTER.

2 ComEd FURNISHES AND INSTALLS THE FOLLOWING EQUIPMENT:

- Q – CONNECTORS FOR CONNECTING CUSTOMER'S WIRES TO SERVICE DROP.
- R – SERVICE DROP DEAD-END.

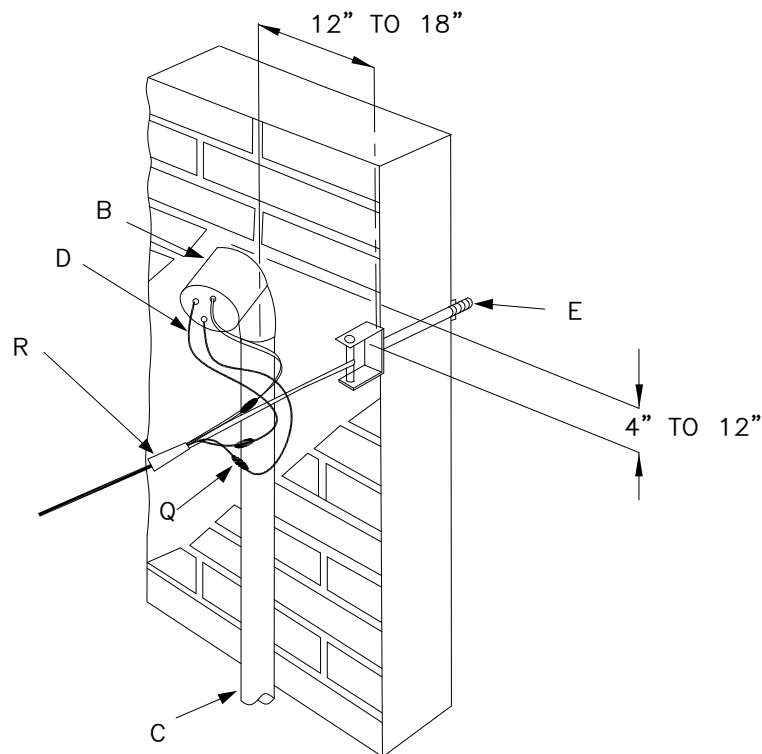
**FIGURE-1**

INSTALLATION ON MASONRY WALL

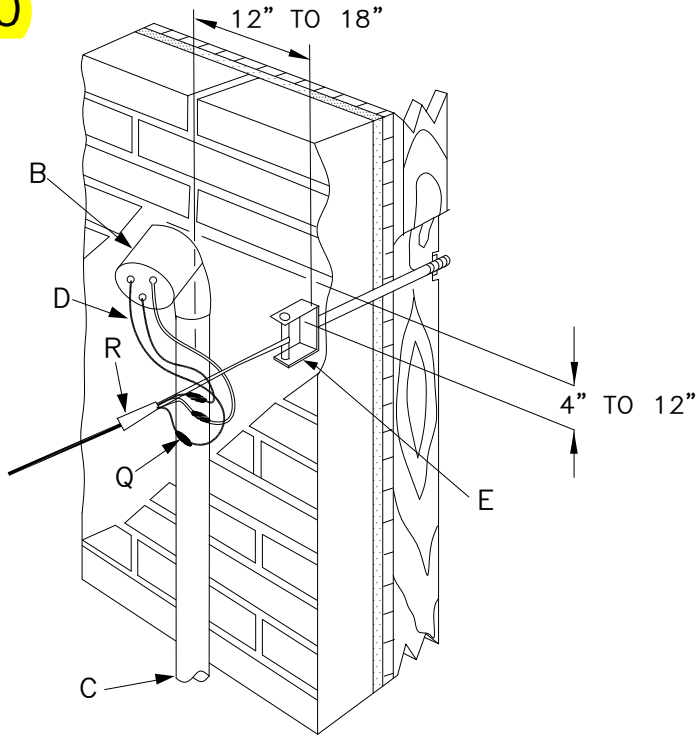

FIGURE-2
 INSTALLATION ON
 BRICK VENEER WALL

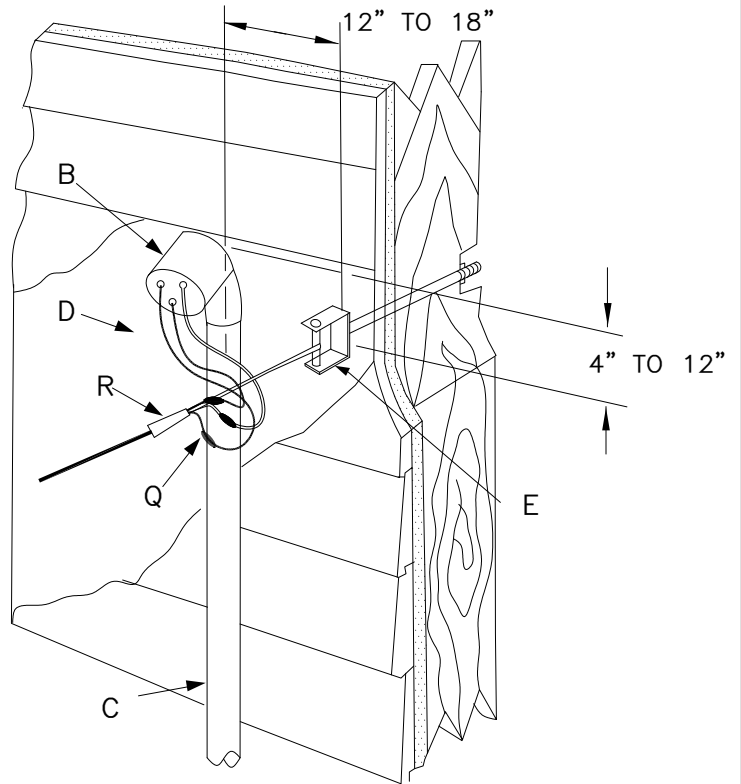

FIGURE-3
 INSTALLATION ON FRAME OR
 STUCCO WALL

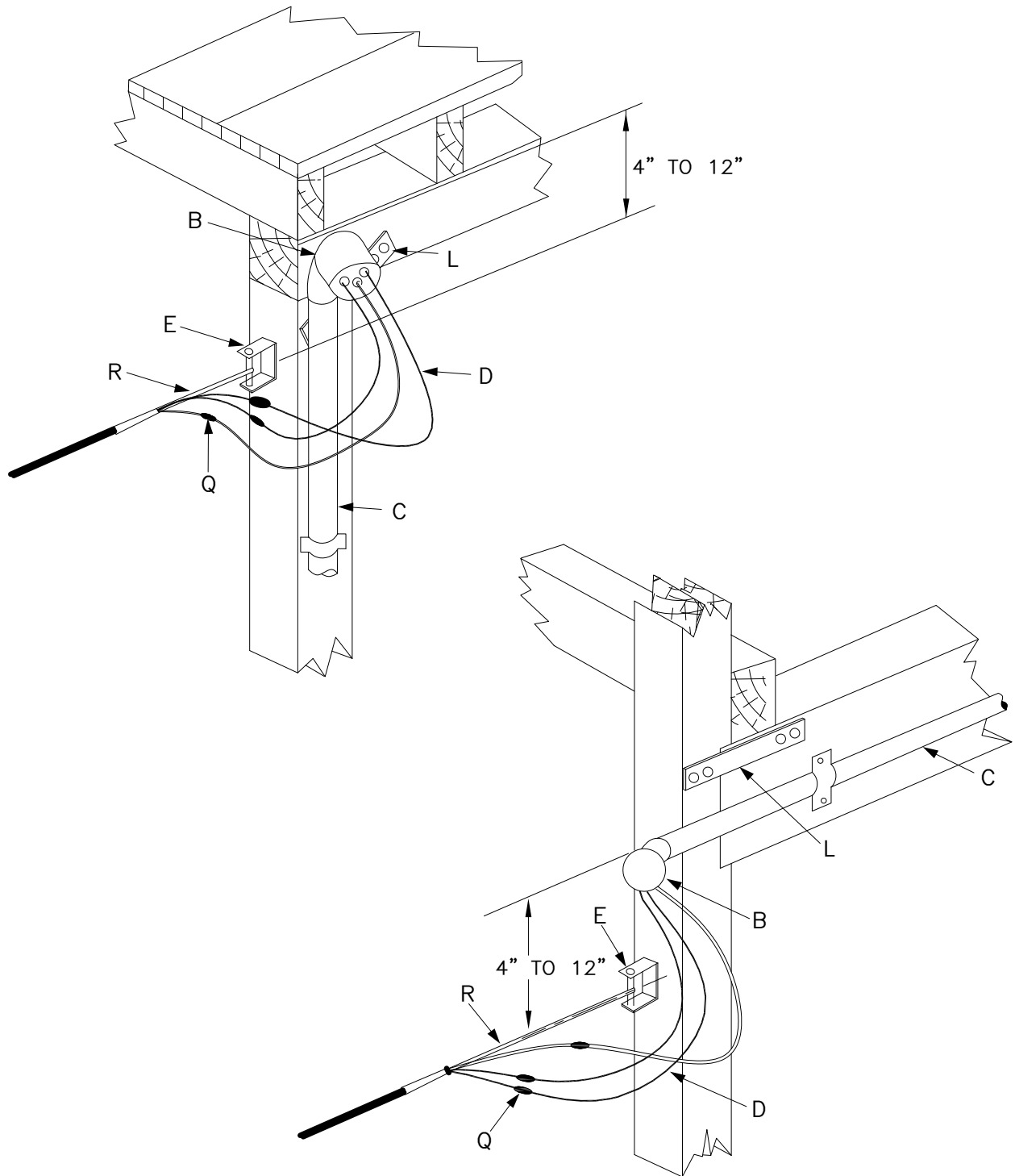

FIGURE-4
 INSTALLATION ON A PORCH POST (HORIZONTAL OR VERTICAL)

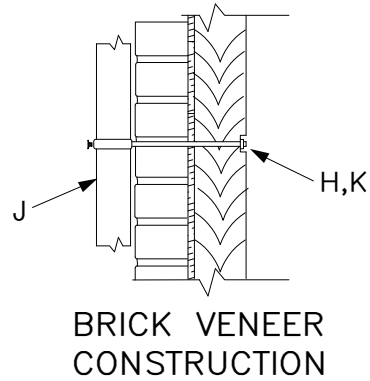
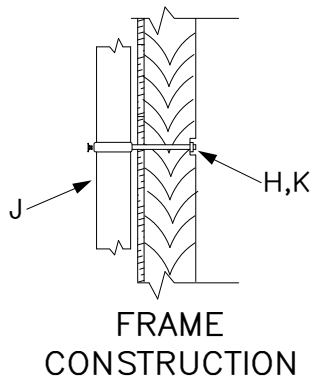
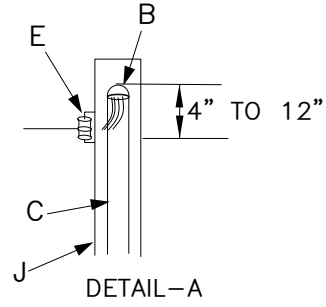
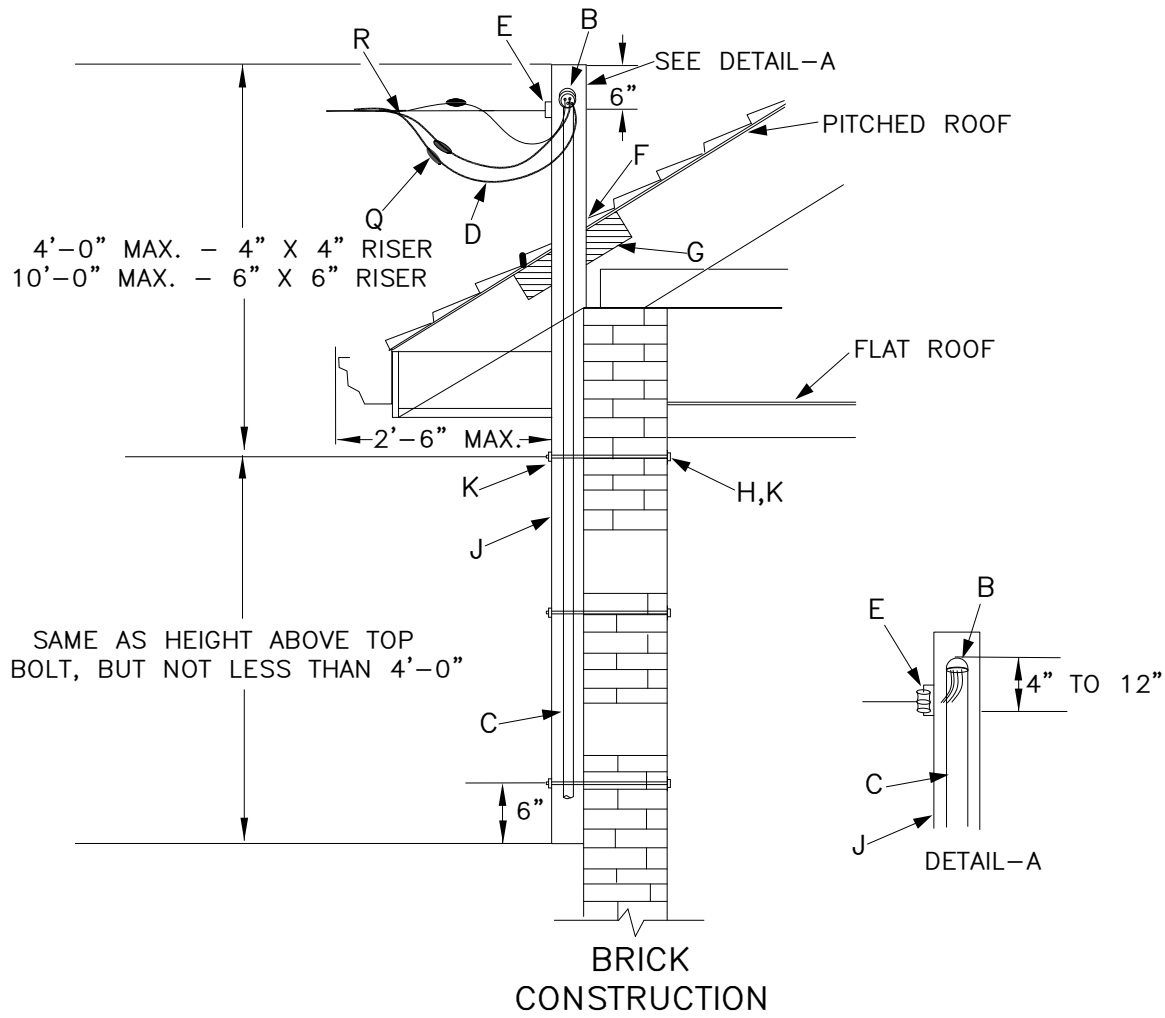

FIGURE-5
SERVICE ATTACHMENT WITH WOOD RISER

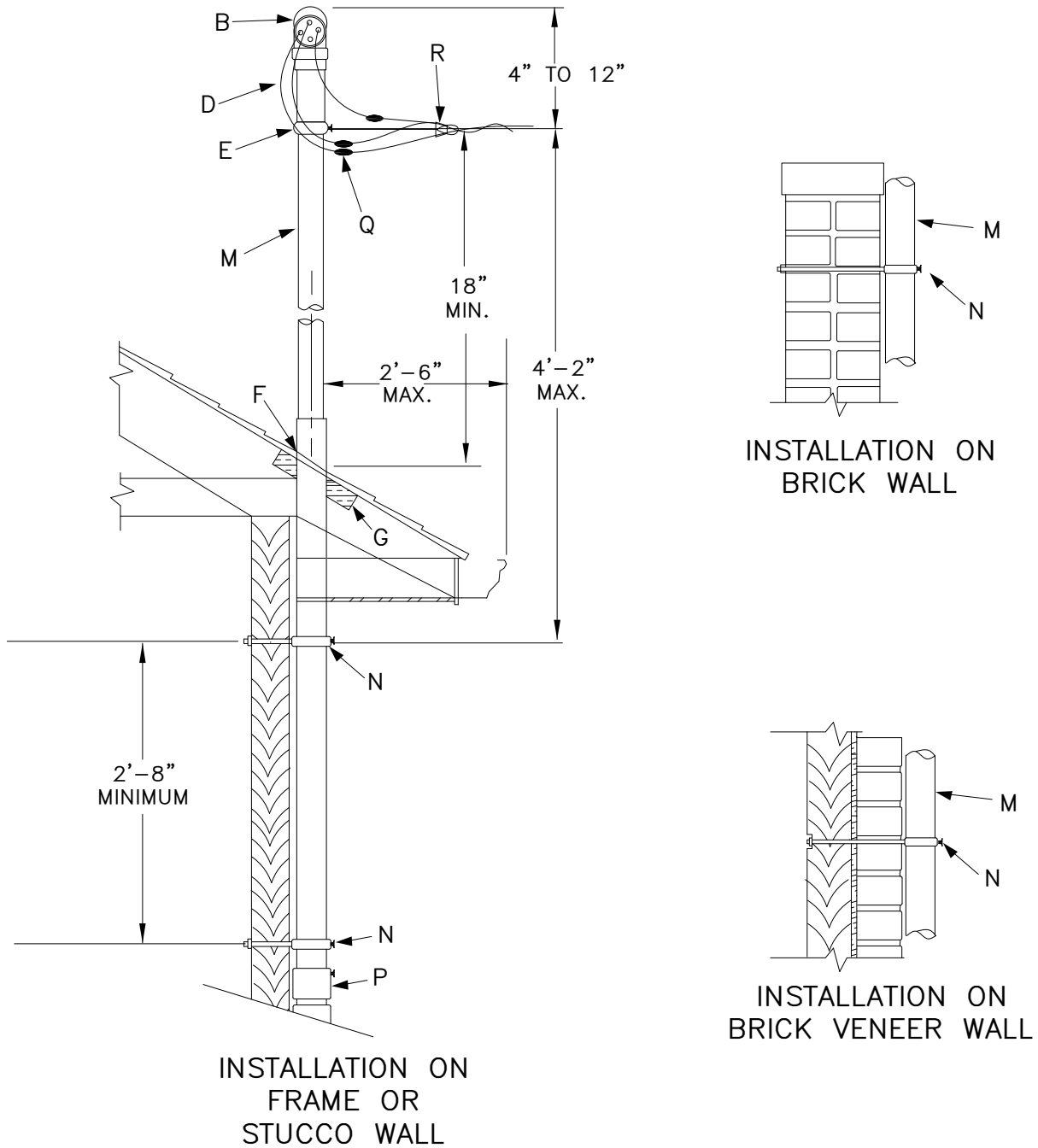
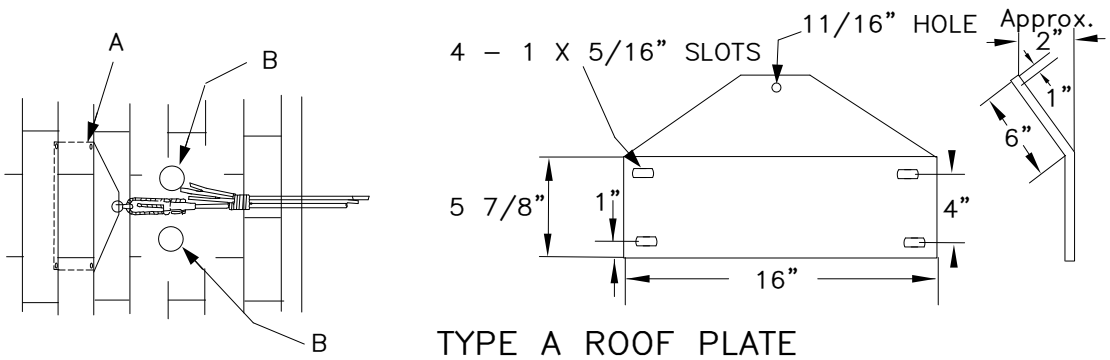
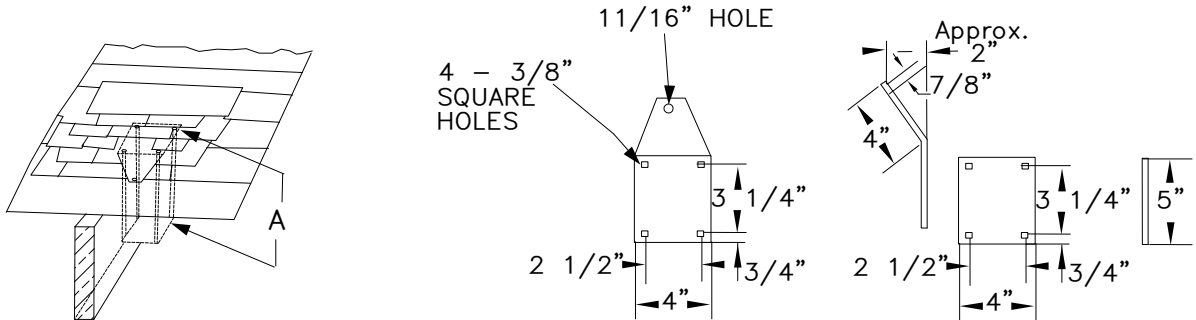

FIGURE-6
SERVICE ATTACHMENT WITH STEEL CONDUIT RISER



TYPE A ROOF PLATE



TYPE B ROOF PLATE

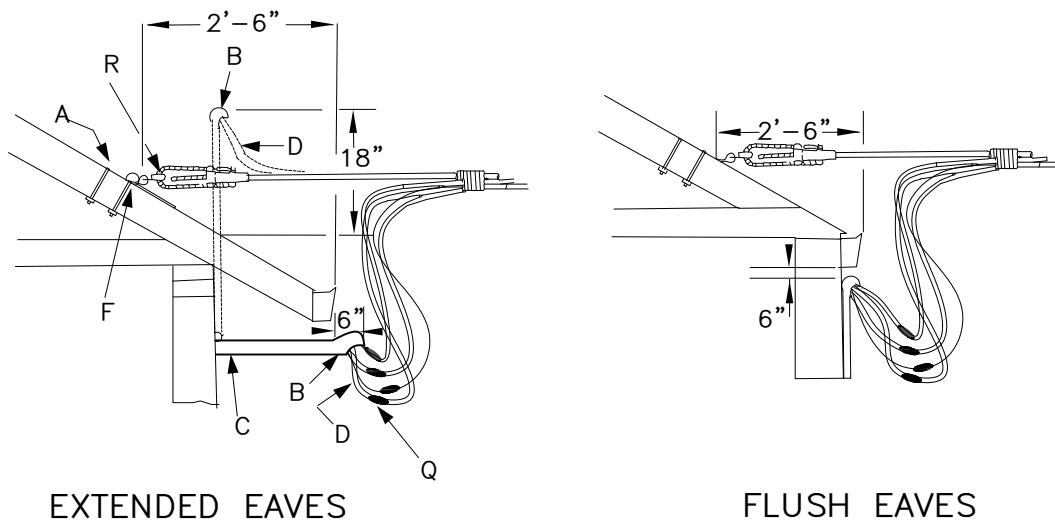

EXTENDED EAVES

FLUSH EAVES

FIGURE-7
ROOF PLATE INSTALLATION

This page intentionally left blank

SERVICE ATTACHMENT – ROW HOUSE

120/240 VOLT

NOTES:

APPLICATION:

- THIS STANDARD DESCRIBES THE REQUIREMENTS FOR INSTALLATION OF SERVICE ATTACHMENTS ON ROW HOUSE TYPE RESIDENCES.

INFORMATION:

- | | |
|---|---|
| <p>1 CUSTOMER FURNISHES, INSTALLS, AND MAINTAINS THE FOLLOWING EQUIPMENT IN ACCORDANCE WITH ComEd SPECIFICATIONS:</p> <p>A- SERVICE HEAD. ALL NEW SERVICE HEADS SHALL BE LOCATED NO MORE THAT 25' ABOVE THE GROUND AND MUST BE POSITIONED SO THAT THE SERVICE WIRE INSTALLATION HAS SAFE ACCESS FROM AN EXTENSION LADDER.</p> <p>B- SERVICE RUN (SEE NOTE 3)</p> <p>C- SERVICE RUN WIRES. CUSTOMER SHOULD ALLOW A MINIMUM OF 18" BEYOND THE SERVICE HEAD TO MAKE CONNECTIONS TO SERVICE DROP WIRES. (SEE NOTE 3)</p> <p>D- METER CONNECTION DEVICE (SEE NOTE 3)</p> <p>E- SERVICE ATTACHMENT BY OTHER STANDARD.</p> | <p>2 ComEd FURNISHES, INSTALLS AND MAINTAINS THE FOLLOWING EQUIPMENT:</p> <p>F- SERVICE DROP (SEE NOTE 3)</p> <p>G- SERVICE DROP DEAD END</p> <p>H- CONNECTORS FOR CONNECTING CUSTOMER'S WIRES TO SERVICE DROP.</p> <p>3 GENERALLY ComEd WILL INSTALL A SERVICE DROP TO EACH SIDE OF THE PARTY WALL. HOWEVER, WHEN ADJACENT ROW HOUSES ARE NOT INDIVIDUALLY OWNED, A COMMON SERVICE RUN TO A MULTIPLE-METER SOCKET MAY BE USED IF REQUESTED BY CUSTOMER. FOR SERVICE RUN WIRES, ALLOW A MINIMUM OF 18" BEYOND THE SERVICE HEAD TO MAKE CONNECTIONS TO THE SERVICE DROP WIRES.</p> |
|---|---|

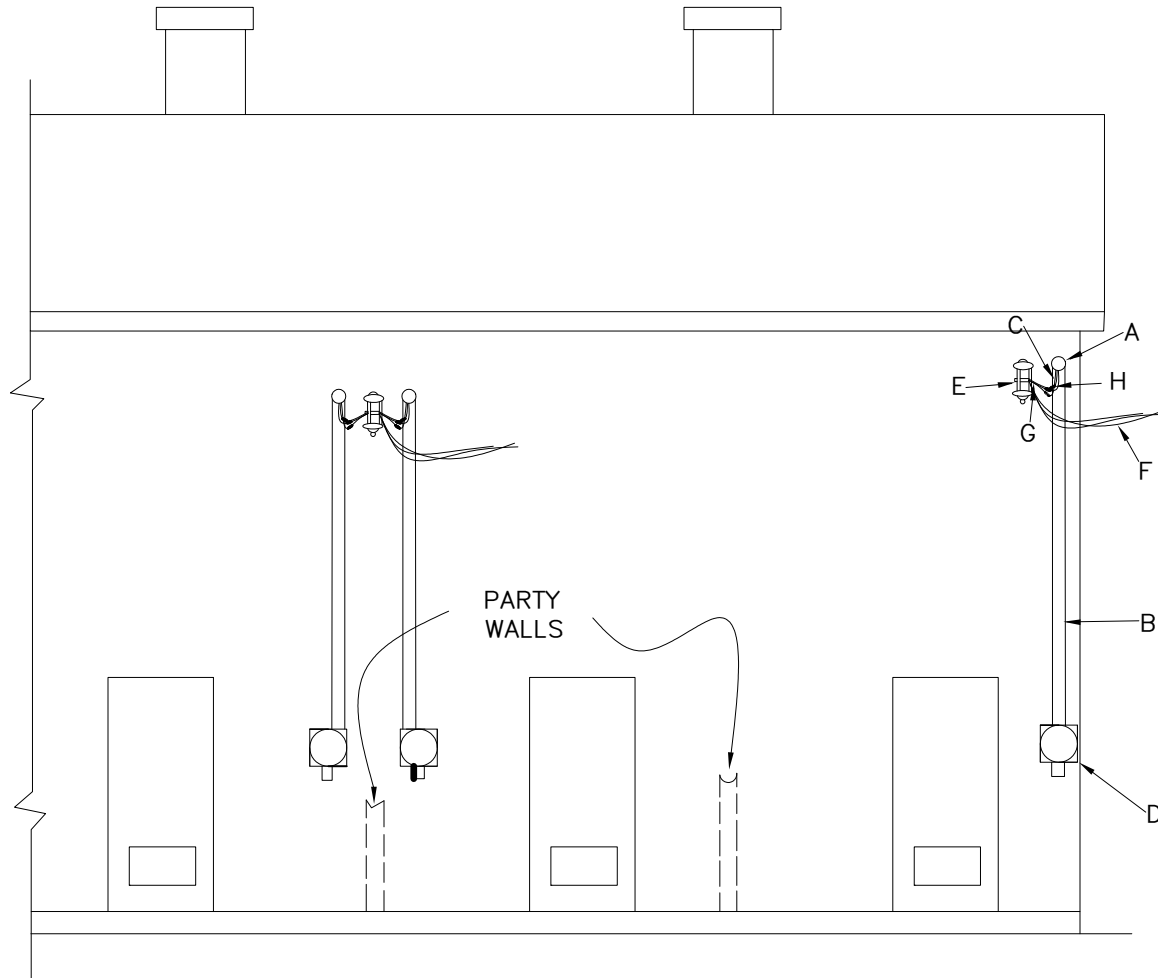

ACAD

This page intentionally left blank

THREE PHASE SERVICE ATTACHMENT

UP TO 200 AMPS

NOTES:

APPLICATION:

- THIS STANDARD DESCRIBES THE REQUIREMENTS FOR THE ATTACHMENT OF THREE PHASE SERVICES OF UP TO 200 AMPS TO A: MASONRY WALL (FIGURE-1), BRICK VENEER WALL (FIGURE-2), FRAME OR STUCCO WALL (FIGURE-3), PORCH POST (FIGURE-4), WOOD RISER (FIGURE-5), STEEL CONDUIT RISER (FIGURE-6) OR ROOF PLATE (FIGURE-7).

INFORMATION:

1 CUSTOMER FURNISHES, INSTALLS AND MAINTAINS THE FOLLOWING EQUIPMENT:

- A – ROOF PLATE. TO BE AT LEAST #10 GAUGE SHEET STEEL, AND BOLTS TO BE AT LEAST 1/4". ROOF PLATES OF TYPE A OR TYPE B ARE ACCEPTABLE.

TYPE A—INSTALL FOUR CARRIAGE BOLTS THROUGH RAFTERS WITH WASHERS AND NUTS ON THE UNDERSIDE OF THE RAFTERS. WHEN PLATES ARE INSTALLED ON RAFTER SPACING OTHER THAN 16", INSTALL A 2x6 TIMBER UNDER TWO RAFTERS. AS AN ALTERNATIVE FOR CARRIAGE BOLTS WHERE THE ROOF PLATE IS SO LOCATED THAT THE FASTENING OF NUTS TO SUCH BOLTS IS IMPRACTICABLE, THE USE OF FOUR 3-1/2" X 1/4" LAG SCREWS WILL BE PERMITTED. THE LAG SCREWS SHALL BE SCREWED, NOT HAMMERED, INTO DRILLED HOLES 3/16" DIAMETER AND 2" DEEP.

TYPE B—INSTALL TWO CARRIAGE BOLTS ON EACH SIDE OF RAFTER WITH NUTS AND SMALL PLATE ON UNDERSIDE OF RAFTER.

- B – SERVICE HEAD. ALL NEW SERVICE HEADS SHALL BE LOCATED NO MORE THAN 25' ABOVE THE GROUND AND MUST BE POSITIONED SO THAT THE SERVICE WIRE INSTALLATION HAS SAFE ACCESS FROM AN EXTENSION LADDER.
- C – SERVICE RUN.
- D – SERVICE RUN WIRES. CUSTOMER SHOULD ALLOW A MINIMUM OF 18" BEYOND THE SERVICE HEAD TO MAKE CONNECTIONS TO SERVICE DROP WIRES.
- E – SERVICE ATTACHMENT – FORKBOLT WITH NUTS AND WASHERS OR EYEPLATE.
- F – METAL FLASHING SEALED WITH MASTIC IS REQUIRED WHERE SERVICE RUN EXTENDS THROUGH ROOF.
- G – 2X4 BLOCKING SOLIDLY INSTALLED BETWEEN RAFTERS IS REQUIRED WHERE RISER EXTENDS THROUGH ROOF.
- H – 5/8" GALVANIZED MOUNTING BOLTS (WITH NUTS) INSTALLED IN CENTER LINE OF STUDS. OMIT MIDDLE BOLT FOR A 4X4 RISER INSTALLATION.
- J – 4X4 OR 6X6 RISER OF PRESERVATIVE TREATED YELLOW PINE, OR EQUIVALENT.
- K – 2-1/4" GALVANIZED SQUARE WASHER.
- L – GALVANIZED IRON 1/8" X 1" X 12" PORCH BRACE WITH FOUR 5/16" HOLES, ONE TO BE INSTALLED ON EACH SIDE. USE 1/4" X 2-1/2" GALVANIZED LAG SCREWS.
- M – RIGID STEEL CONDUIT – 2-1/2" FOR 100 AMPERE OR SMALLER, OR 3" FOR LARGER SERVICE ENTRANCE EQUIPMENT, OR METALLIC RACEWAY OF EQUIVALENT STRENGTH MAY BE USED.

INFORMATION (CONTINUED):

N – MOUNTING CLAMP WITH 1/2" BOLTS, NUTS, AND WASHERS. FOR FRAME, STUCCO, OR BRICK VENEER, INSTALL BOLTS IN CENTER LINE OF STUDDING OR, IN THE CASE OF TWO BOLT STRAP ATTACHMENT, STRADDLING A STUD WITH AN ANCHOR PLATE BRIDGING STUD.

P – METER CONNECTION DEVICE ADAPTER.

2 ComEd FURNISHES, INSTALLS AND MAINTAINS THE FOLLOWING EQUIPMENT:

Q – CONNECTORS FOR CONNECTING CUSTOMER'S WIRES TO SERVICE DROP.

R – SERVICE DROP DEAD-END.

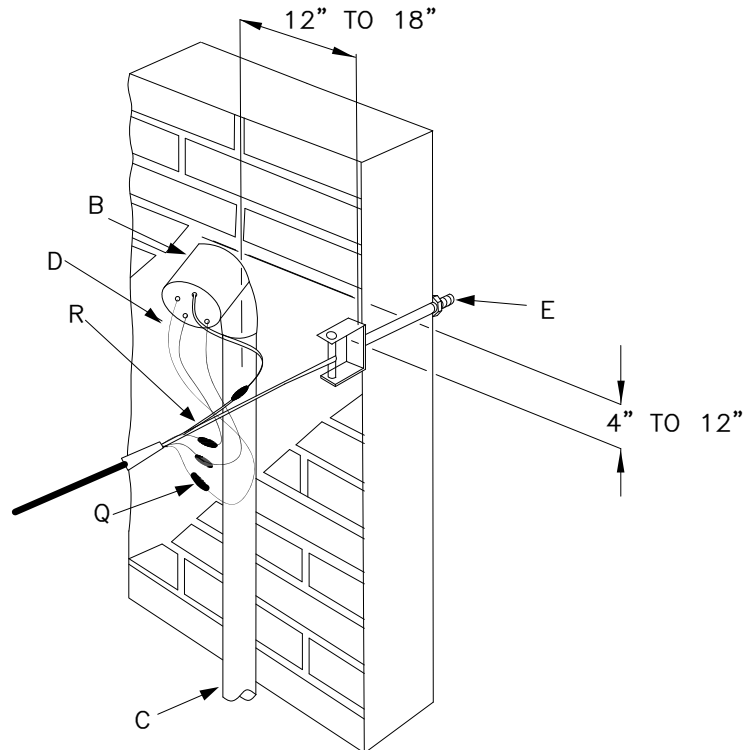

FIGURE-1
MASONRY WALLS

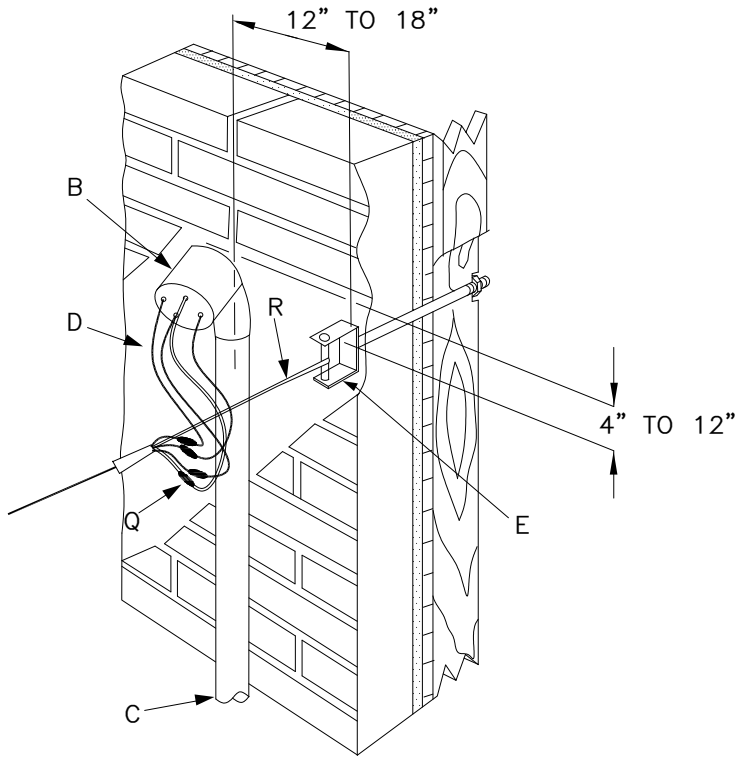

FIGURE-2
BRICK VENEER WALL
INSTALLATION

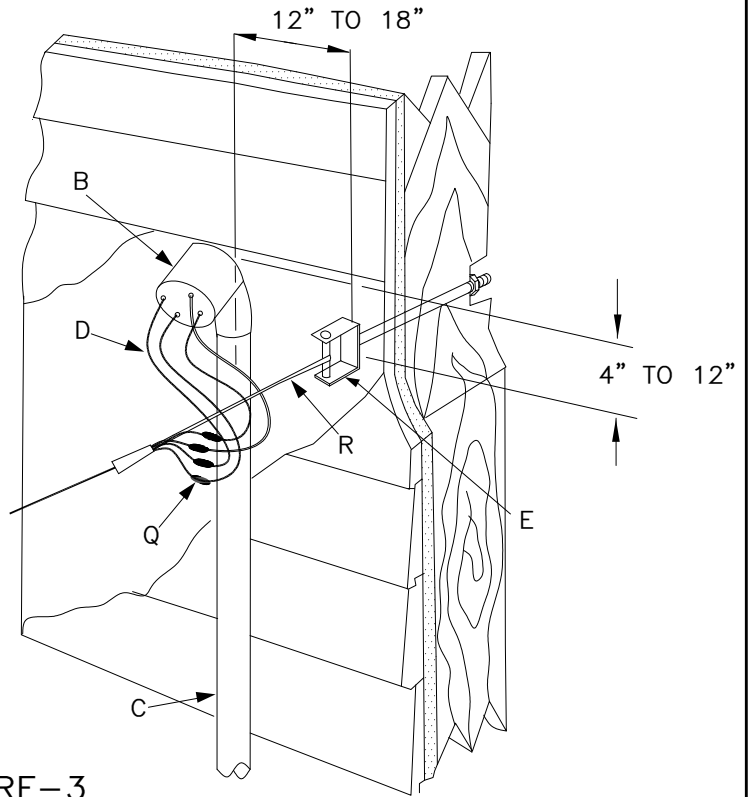

FIGURE-3
FRAME OR STUCCO WALL
INSTALLATION

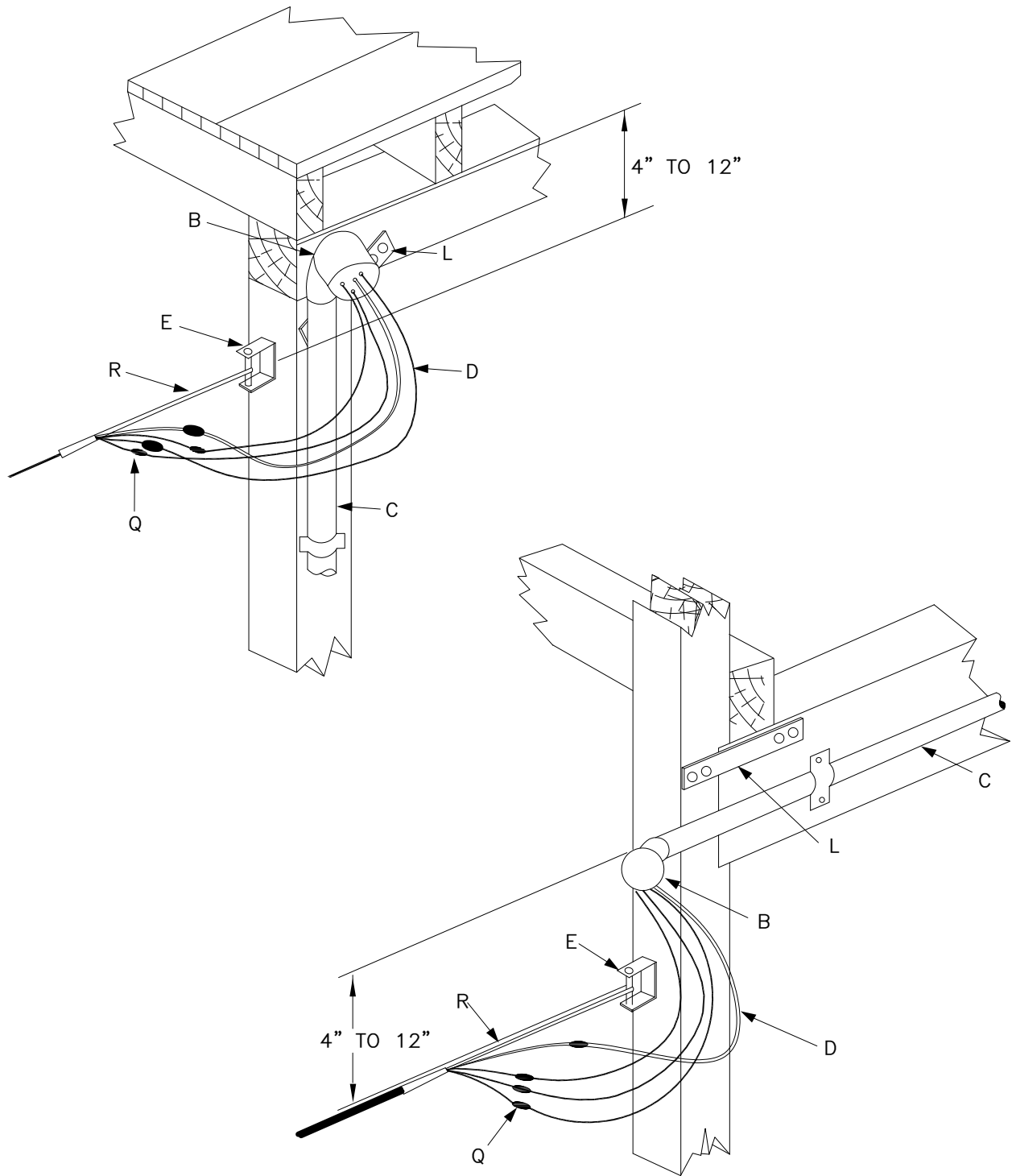
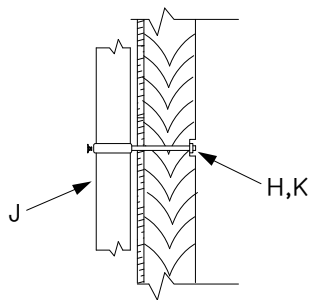
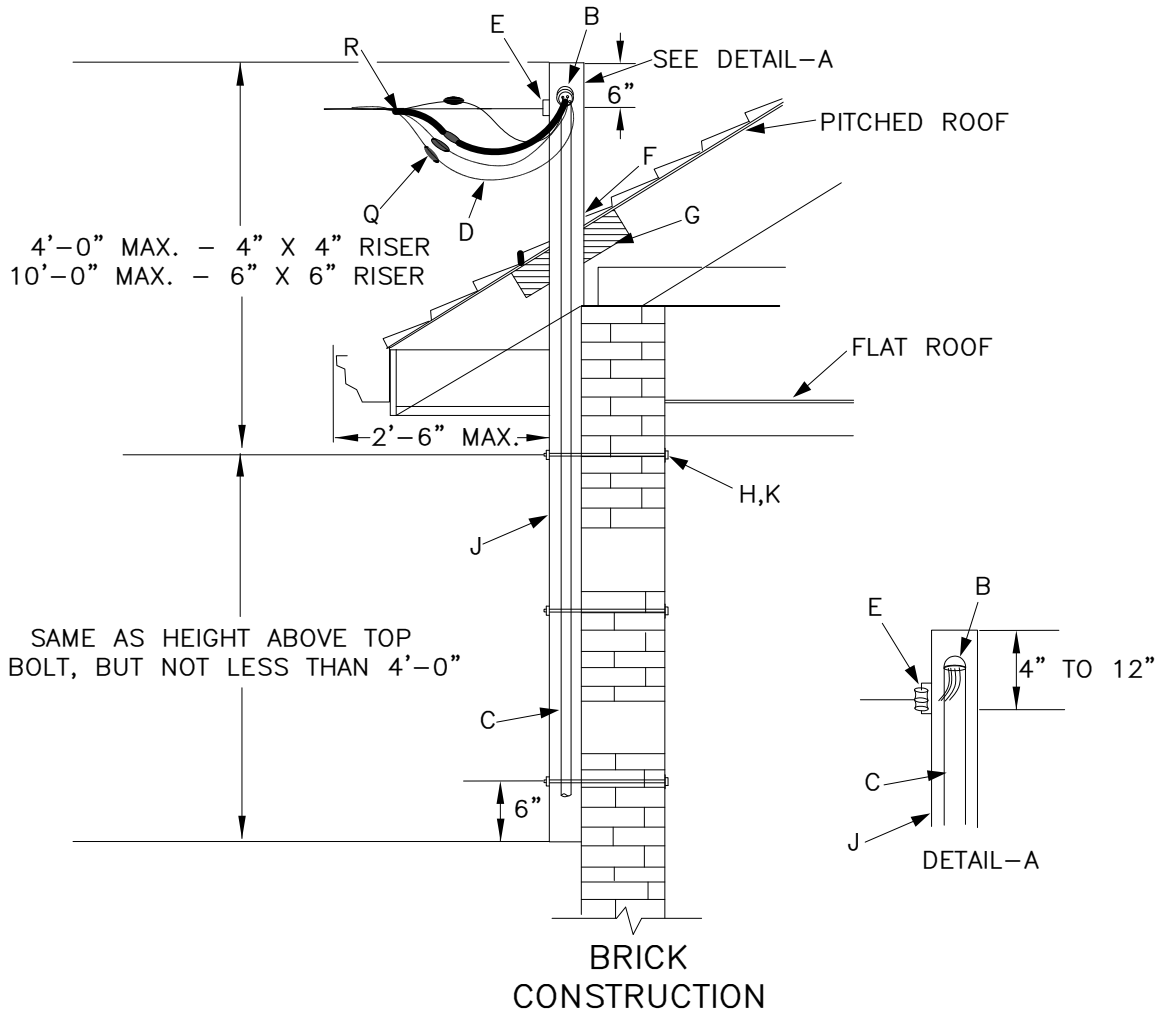
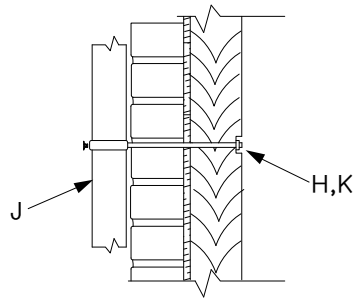

FIGURE-4
 SERVICE ATTACHMENT ON PORCH POST



FRAME CONSTRUCTION



BRICK VENEER CONSTRUCTION

FIGURE-5
SERVICE ATTACHMENT USING WOOD RISER

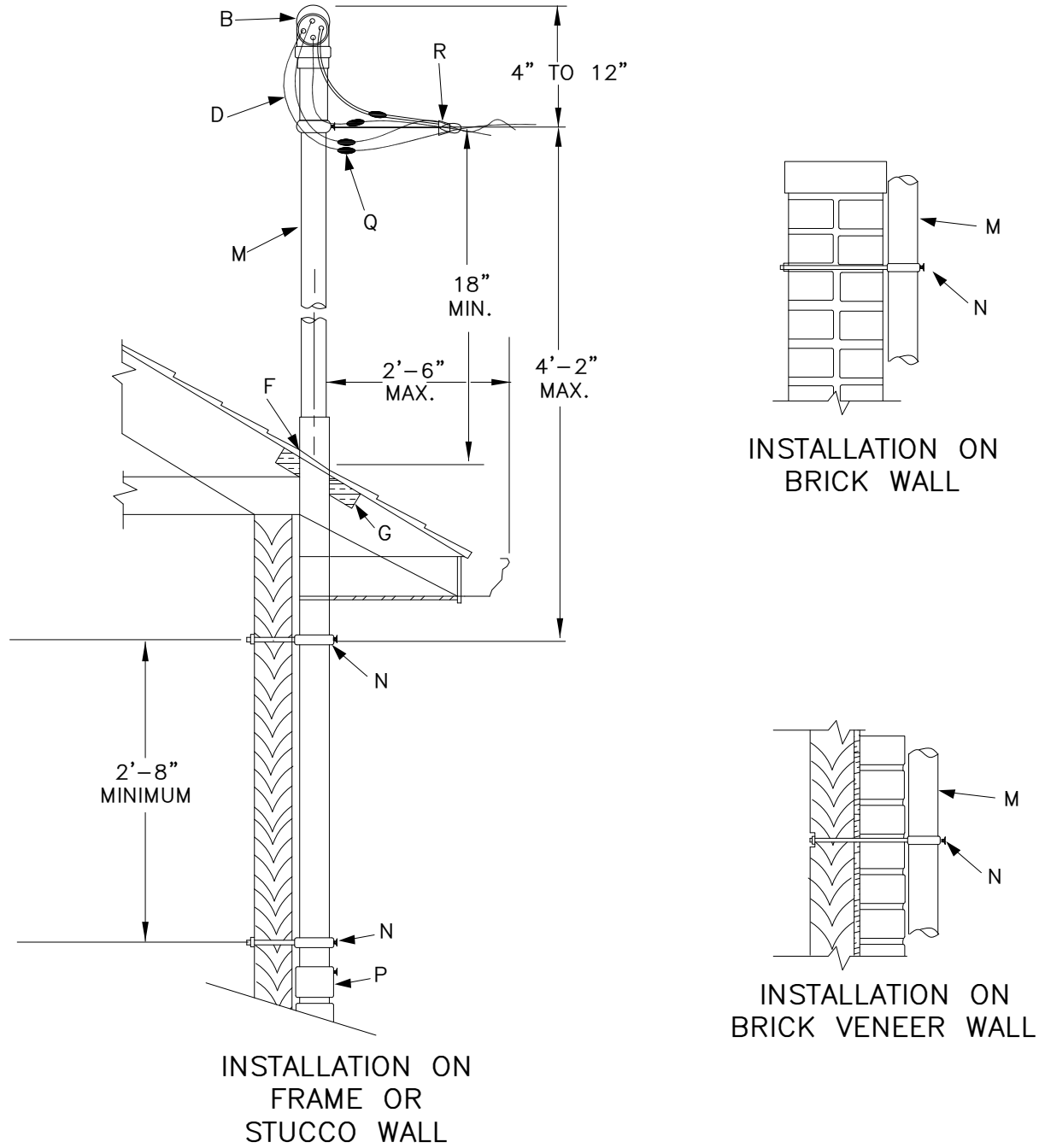
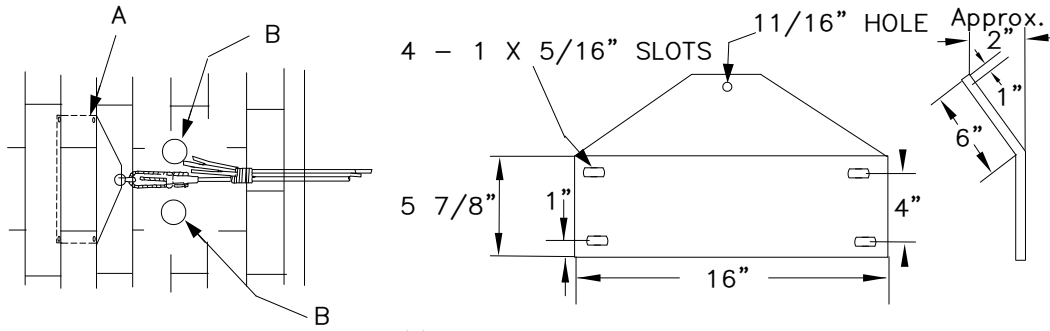
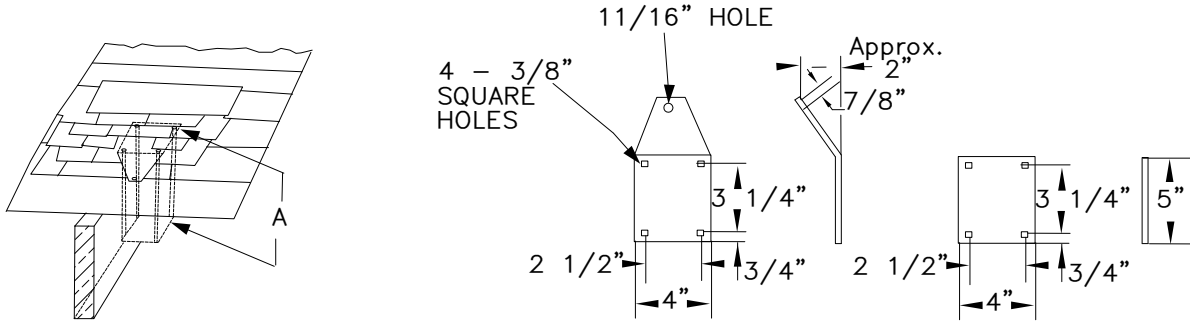

FIGURE-6
SERVICE ATTACHMENT WITH STEEL CONDUIT RISER



TYPE A ROOF PLATE



TYPE B ROOF PLATE

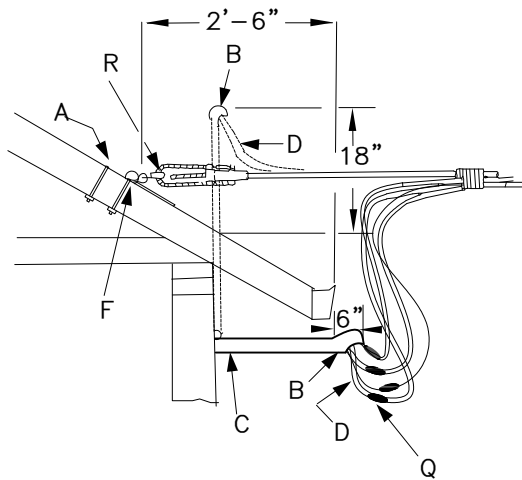

EXTENDED EAVES

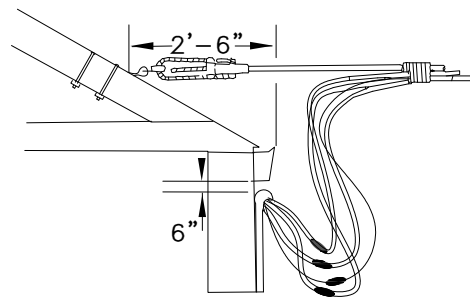

FLUSH EAVES

FIGURE-7
ROOF PLATE INSTALLATION

This page intentionally left blank

SERVICE ATTACHMENT INSTALLATION

400 AMPS TO 1200 AMPS, 1-PH OR 3-PH

NOTES:

APPLICATION:

- THIS STANDARD DESCRIBES THE REQUIREMENTS FOR THE INSTALLATION OF A SERVICE ENTRANCE WITH CAPACITY OF 400 AMPERES UP TO 1200 AMPERES. SERVICES OVER 1200 AMPERES WILL NORMALLY REQUIRE AN ESS OR RSS.

INFORMATION:

1 CUSTOMER FURNISHES, INSTALLS, AND MAINTAINS THE FOLLOWING EQUIPMENT:

- A – SERVICE HEAD. ALL NEW SERVICE HEADS SHALL BE LOCATED NO MORE THAN 25' ABOVE THE GROUND, AND MUST BE POSITIONED SO THAT THE SERVICE WIRE INSTALLATION HAS SAFE ACCESS FROM AN EXTENSION LADDER.
- B – SERVICE RUN.
- C – SERVICE RUN WIRES (ALLOW SUFFICIENT WIRE BEYOND THE SERVICE HEAD TO MAKE CONNECTIONS TO SERVICE DROP WIRES)
- D – GALVANIZED STEEL PLATE (1/4" X 6" X 16")
- E – TWO FORK BOLTS OR TWO 5/8" GALVANIZED BOLTS WITH 5/8" NUTS, LOCKWASHERS AND CLEVIS OR EQUIVALENT.

2 ComEd FURNISHES, INSTALLS, AND MAINTAINS THE FOLLOWING EQUIPMENT:

- F – SERVICE DROP DEAD-ENDS
- G – CONNECTORS FOR CONNECTING CUSTOMER'S WIRES TO SERVICE DROP.

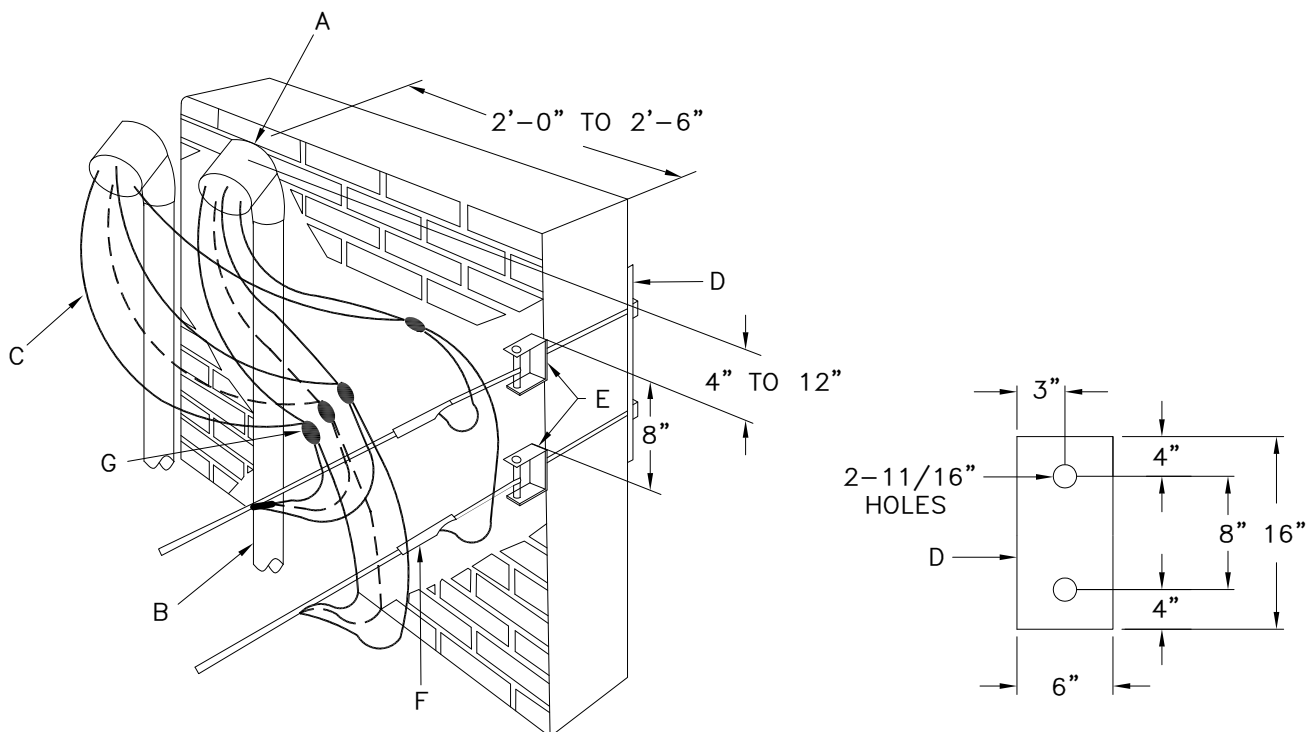

ACAD

This page intentionally left blank

BOX TYPE SERVICE HEAD ASSEMBLY

NOTES:

APPLICATION

- THIS STANDARD DESCRIBES THE REQUIREMENTS FOR THE INSTALLATION OF A BOX TYPE SERVICE HEAD ASSEMBLY.

INFORMATION

1. CUSTOMER FURNISHES, INSTALLS, AND MAINTAINS THE FOLLOWING EQUIPMENT:

- SERVICE HEAD AND 1" ELECTRIC SLATE OR EQUIVALENT PANEL WITH HOLES DRILLED TO ACCOMMODATE THE CONDUCTORS.
- ALL NEW SERVICE HEADS SHALL BE LOCATED NO MORE THAN 25 FEET ABOVE THE GROUND, AND MUST BE POSITIONED SO THAT THE SERVICE WIRE INSTALLATION HAS SAFE ACCESS FROM AN EXTENSION LADDER.
- BOX SHALL BE MADE OF AT LEAST #10 GAUGE SHEET STEEL, GALVANIZED AFTER FORMING. IF CONSTRUCTED OF ANOTHER METAL, IT MUST HAVE COMPARABLE STRENGTH AND WEATHER RESISTANCE.
- KNOCKOUTS MAY BE INSTALLED AS REQUIRED IN BACK, SIDES, OR BOTTOM.
- HOLES IN PANEL (1" SLATE OR EQUIVALENT) SHALL BE EQUALLY SPACED AND SHALL ALLOW AT LEAST 1 1/2" OF MATERIAL BETWEEN HOLES.
- TO PREVENT THE ENTRANCE OF WATER INTO THE SERVICE RUN, THE PANEL SHALL BE INSTALLED AT SUCH AN ANGLE THAT THE LOWER INSIDE EDGE OF THE HOLE WILL NOT BE LOWER THAN THE TOP OUTSIDE EDGE WHEN INSTALLED OR, IF THE PANEL CANNOT BE INSTALLED AT SUCH ANGLE, A DUCT SEALING COMPOUND SHALL BE USED.

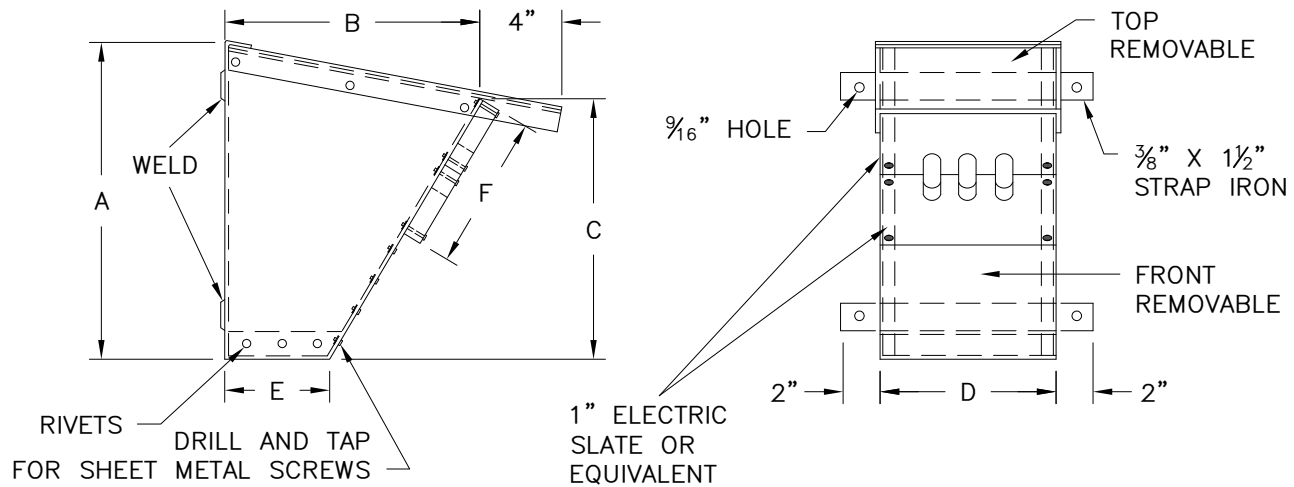

NUMBER OF CONDUITS	DIMENSION IN INCHES					
	A	B	C	D	E	F
1	24	18	18	14	8	12
2	24	18	18	14	8	12
3	30	20	24	18	8	16
4	32	24	28	28	8	20
6	36	26	32	36	15	20

2. FIGURES 1 THROUGH 5 SHOW THE VARIOUS ARRANGEMENTS OF WIRES IN THE SERVICE HEAD. THE PHASE ARRANGEMENT SHALL PERMIT CONNECTION TO ComEd's SERVICE DROP WITHOUT CROSSING WIRES OUTSIDE THE SERVICE HEAD. (THREE-WIRE SERVICE IS SHOWN; FOUR-WIRE SERVICE TO BE ARRANGED SIMILARLY, SEE NOTE 4.)
3. FOR SINGLE-PHASE, THREE-WIRE, 120/240 VOLT SERVICE, THE NEUTRAL SHALL BE LOCATED IN THE CENTER POSITION.
4. FOR A THREE-PHASE, FOUR-WIRE SERVICE OR THREE-PHASE, THREE-WIRE SERVICE WITH A FOURTH GROUNDED CONDUCTOR, THE PANEL SHALL BE EXTENDED ONE POSITION AND THE NEUTRAL OR GROUNDED CONDUCTOR SHALL BE LOCATED AT EITHER END OF THE PANEL.
5. THE LOCATION OF SERVICE HEAD SHALL BE APPROVED BY ComEd BEFORE INSTALLATION.
6. EACH CONDUIT SHALL CONTAIN ONE CONDUCTOR FOR EACH PHASE OF THE SERVICE DROP, AND A NEUTRAL CONDUCTOR, IF SUCH CONDUCTOR IS PRESENT IN THE SERVICE DROP. IF A GROUNDED CONDUCTOR IS PRESENT, THE CUSTOMER SHALL INDICATE SUCH CONDUCTOR, WHICH MAY BE INSTALLED WITH THE PHASE WIRES IN ANY ONE OF THE CONDUITS, OR IN A SEPARATE CONDUIT.

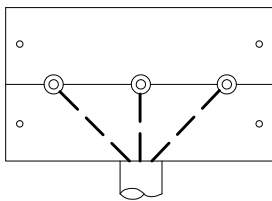

FIGURE 1
3 CABLES
1 CONDUIT

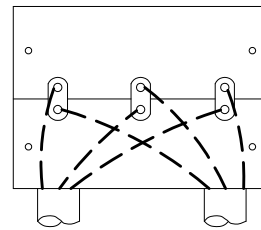

FIGURE 2
6 CABLES
2 CONDUITS

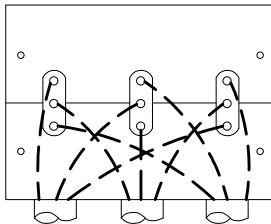

FIGURE 3
9 CABLES
3 CONDUITS

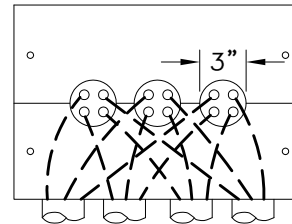

FIGURE 4
12 CABLES
4 CONDUITS

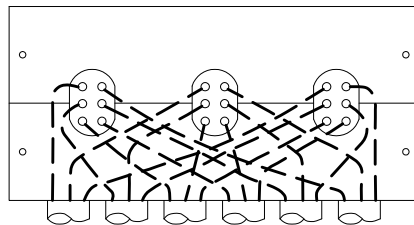

FIGURE 5
18 CABLES
6 CONDUITS

RECESSED SERVICE HEAD

BUS IN DUCT

SERVICE ENTRANCE

NOTES:

APPLICATION

- THIS STANDARD DESCRIBES THE REQUIREMENTS FOR THE INSTALLATION OF A RECESSED SERVICE HEAD.

INFORMATION

1. CUSTOMER FURNISHES, INSTALLS, AND MAINTAINS THE FOLLOWING EQUIPMENT:

- A – A 1 INCH ELECTRIC SLATE OR EQUIVALENT PANEL WITH HOLES DRILLED TO ACCOMMODATE THE CONDUCTORS.
 - a. FOR DIMENSIONS AND SPACING OF HOLES FOR APPROPRIATE PANEL, SEE DETAILS 1 TO 4.
 - b. FOR 1-PHASE, 3-WIRE, 120/240 VOLT SERVICE, THE NEUTRAL SHALL BE LOCATED IN THE CENTER POSITION.
 - c. FOR A 3-PHASE, 4-WIRE SERVICE OR 3-PHASE, 3-WIRE SERVICE WITH A FOURTH CONDUCTOR WHICH IS GROUNDED, THE PANEL SHALL BE EXTENDED ONE POSITION. THE NEUTRAL OR GROUNDED CONDUCTOR SHALL BE LOCATED AT EITHER END OF THE PANEL.
 - d. FOR INSTALLATION, SEE DETAIL 5.
 - e. TO PREVENT THE ENTRANCE OF WATER, DUCT SEALING COMPOUND SHALL BE USED IF THE LOWER INSIDE EDGE OF THE HOLES IS LOWER THAN THE TOP OUTSIDE EDGE WHEN THE PANEL IS IN PLACE.
- B – DRIP CAP SHALL NOT EXTEND MORE THAN 8 INCHES FROM BUILDING WALL UNLESS SPECIFIC PERMISSION IS OBTAINED FROM ComEd.
- C – LUGS FOR THE CONNECTION OF THE SERVICE CONNECTION TO THE INSIDE BUS OR, IN THE CASE OF A GROUNDED CONDUCTOR, TO THE INSIDE CABLE IF USED BY THE CUSTOMER IN PLACE OF BUS. CUSTOMER TO PROVIDE THE NECESSARY NUTS AND BOLTS AND CONNECT LUGS TO BUS OR CABLE. THE LUGS WILL BE FURNISHED AND ATTACHED TO THE CABLES BY THE CUSTOMER OR ComEd, WHICHEVER FURNISHES THE CABLE (SEE ITEM 4). LUGS FURNISHED BY ComEd REQUIRE TWO 9/16" HOLES ON 1 3/4" CENTERS FOR TWO 1/2" BOLTS.
- D – THE LOCATION OF A RECESSED SERVICE HEAD SHALL BE APPROVED BY ComEd BEFORE INSTALLATION. ALL NEW SERVICE HEADS SHALL BE LOCATED NO MORE THAN 25 FEET ABOVE THE GROUND, AND MUST BE POSITIONED SO THAT THE SERVICE WIRE INSTALLATION HAS SAFE ACCESS FROM AN EXTENSION LADDER.

2. ComEd FURNISHES, INSTALLS, AND MAINTAINS THE FOLLOWING EQUIPMENT:

- E – SERVICE CONNECTION. PORTION WITHIN BUILDING TO CUSTOMER'S BUS SHALL NOT EXCEED THREE FEET.

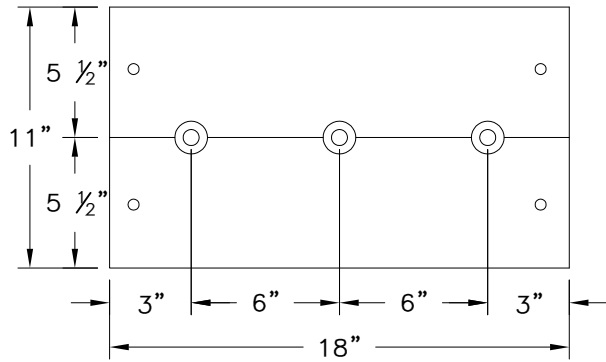

DETAIL 1
3 CABLES

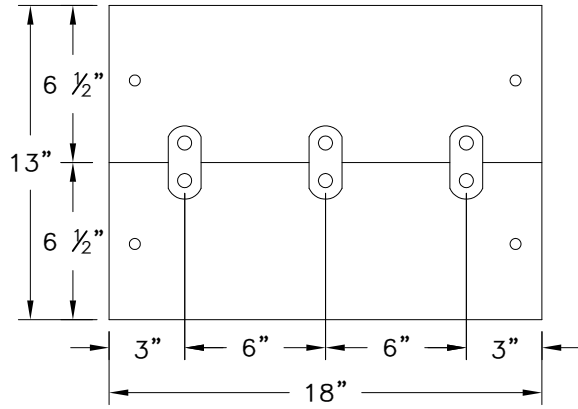

DETAIL 2
6 CABLES

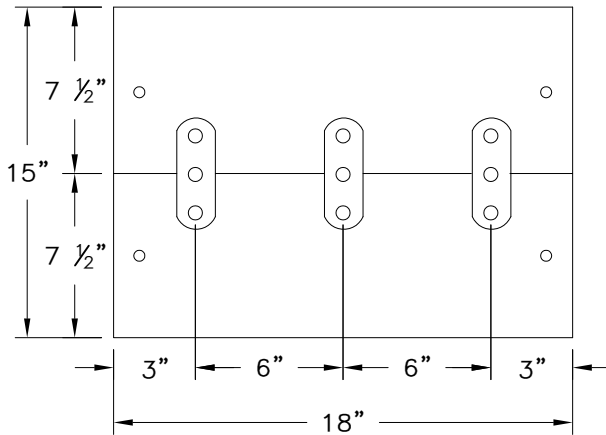

DETAIL 3
9 CABLES

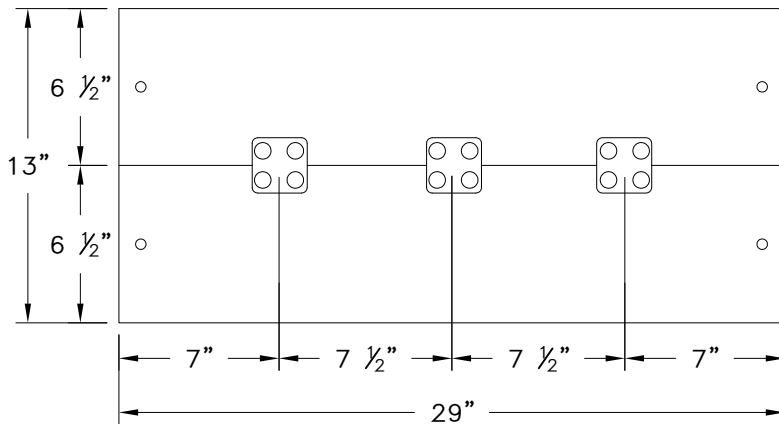

DETAIL 4
12 CABLES

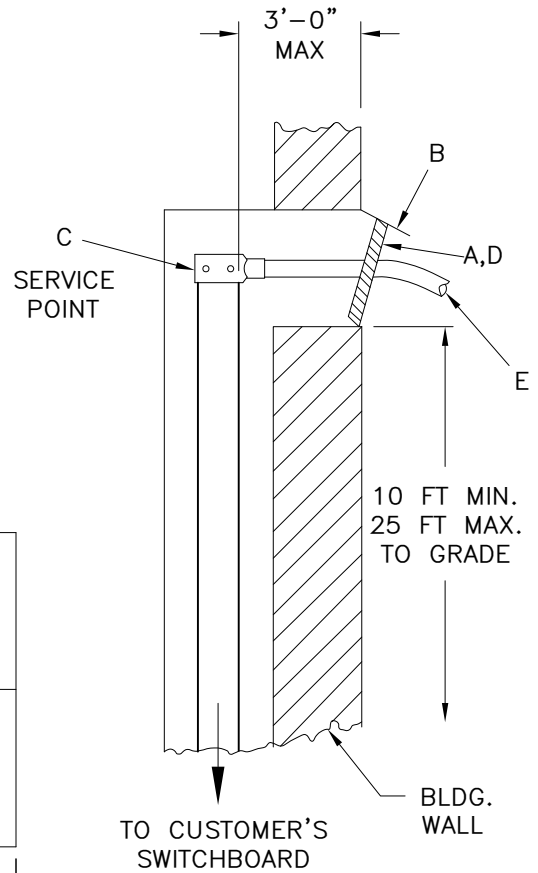

DETAIL 5

CUSTOMER SERVICE POLE – RURAL APPLICATIONS

OUTDOOR METER CONNECTION DEVICE

3-WIRE, 120/240V SUPPLY ONLY

NOTES:

APPLICATION

- THIS STANDARD DESCRIBES THE REQUIREMENTS FOR THE INSTALLATION OF A CUSTOMER SERVICE POLE, AND A 3-WIRE, 120/240V, OUTDOOR METER CONNECTION DEVICE FOR RURAL APPLICATIONS.

INFORMATION

1. CUSTOMER FURNISHES, INSTALLS, AND MAINTAINS THE FOLLOWING EQUIPMENT:

- A – TREATED POLE. (MINIMUM REQUIREMENTS – CLASS #7; LENGTH, 25 FEET).
- B – SERVICE ENTRANCE CABLE WITH CLAMPS SPACED AT A MAXIMUM OF THREE FEET, OR CONDUCTORS IN CONDUIT. ALLOW SUFFICIENT WIRE TO MAKE CONNECTION TO SERVICE DROP WIRE. WHEN CONDUIT IS USED, INSTALL METAL CONDUIT TO 10 FEET ABOVE GROUND LEVEL AND NONMETALLIC RIGID CONDUIT WHERE USED ABOVE 10 FEET.
- C – SERVICE HEADS. INSTALL ABOVE THE RELATED FORK BOLTS AS SHOWN IN DETAIL-1. ALL NEW SERVICE HEADS SHALL BE LOCATED NO MORE THAN 25 FEET ABOVE THE GROUND, AND MUST BE POSITIONED SO THAT THE SERVICE WIRE INSTALLATION HAS SAFE ACCESS FROM AN EXTENSION LADDER.
- D – GROUND ROD, CONDUCTOR AND ASSOCIATED CONDUIT AND CLAMPS FOR GROUNDING METALLIC COMPONENTS.
- E – WEATHER-TIGHT CABLE CONNECTORS OR CONDUIT CONNECTORS.
- F – FORK BOLTS.
- G – APPROVED METER CONNECTION DEVICE.

2. ComEd FURNISHES, INSTALLS, AND MAINTAINS THE FOLLOWING EQUIPMENT:

- H – SERVICE DROP DEAD-END.
- J – CONNECTORS FOR CONNECTING CUSTOMER'S WIRE TO SERVICE DROP. CUSTOMER TO NOTIFY ComEd OF CABLE SIZE.

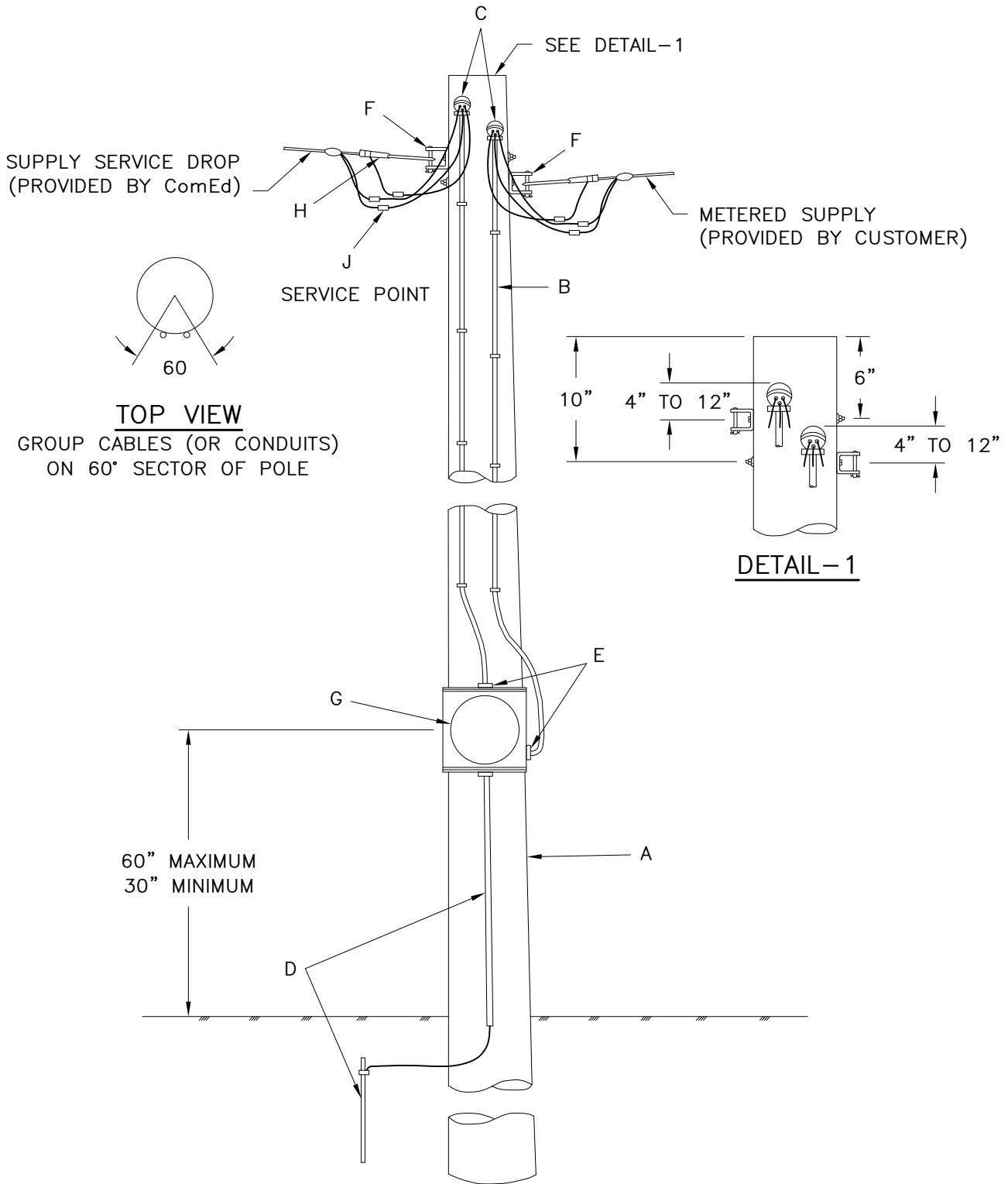

INSTALLATION OF CUSTOMER SERVICE POLE AND OUTDOOR METER CONNECTION DEVICE
 3-WIRE, 120/240V ONLY
 RURAL INSTALLATIONS

CUSTOMER SERVICE POLE – TRAILER PARK

METER INSTALLATION

3-WIRE, 120/240V SUPPLY ONLY

NOTES:

APPLICATION

- THIS STANDARD DESCRIBES THE REQUIREMENTS FOR THE INSTALLATION OF A CUSTOMER SERVICE POLE, AND A 3-WIRE, 120/240V, OUTDOOR METER CONNECTION DEVICE FOR TRAILER PARK APPLICATIONS.

INFORMATION

1. CUSTOMER FURNISHES, INSTALLS, AND MAINTAINS THE FOLLOWING EQUIPMENT:

- A – TREATED POLE. (MINIMUM REQUIREMENTS – CLASS #7; LENGTH, 25 FEET).
- B – SERVICE ENTRANCE CABLE WITH CLAMPS SPACED AT A MAXIMUM OF THREE FEET, OR CONDUCTORS IN CONDUIT. ALLOW SUFFICIENT WIRE TO MAKE CONNECTION TO SERVICE DROP WIRE. WHEN CONDUIT IS USED, INSTALL METAL CONDUIT TO 10 FEET ABOVE GROUND LEVEL AND NONMETALLIC RIGID CONDUIT WHERE USED ABOVE 10 FEET.
- C – SERVICE HEAD. INSTALL ABOVE FORK BOLT AS SHOWN IN DETAIL-1. SERVICE HEAD SHALL BE LOCATED NO MORE THAN 25 FEET ABOVE THE GROUND, AND MUST BE POSITIONED SO THAT THE SERVICE WIRE INSTALLATION HAS SAFE ACCESS FROM AN EXTENSION LADDER.
- D – WEATHER-TIGHT CABLE CONNECTORS OR CONDUIT CONNECTORS.
- E – TWO-POSITION APPROVED METER CONNECTION DEVICE WITH CECHA STAMP. PROVISION FOR FOUR TRAILERS MAY BE MADE BY DUPLICATING THE INSTALLATION ON THE OPPOSITE SIDE OF THE POLE. EXTENSION OF LINE CONDUCTORS BETWEEN THE TWO LOWER METER CONNECTION DEVICES SHALL BE WEATHER-TIGHT. CUSTOMER TO PROVIDE APPROPRIATE DISCONNECTING MEANS.
- F – GROUND ROD, CONDUCTOR AND ASSOCIATED CONDUIT AND CLAMPS FOR GROUNDING METALLIC COMPONENTS.
- G – FORK BOLT.

2. ComEd FURNISHES, INSTALLS, AND MAINTAINS THE FOLLOWING EQUIPMENT ONLY IF SERVICE DROP TERMINATES AT THE POLE.

- H – SERVICE DROP DEAD-END.
- J – CONNECTORS FOR CONNECTING CUSTOMER'S WIRE TO SERVICE DROP. CUSTOMER TO NOTIFY ComEd OF WIRE SIZE.

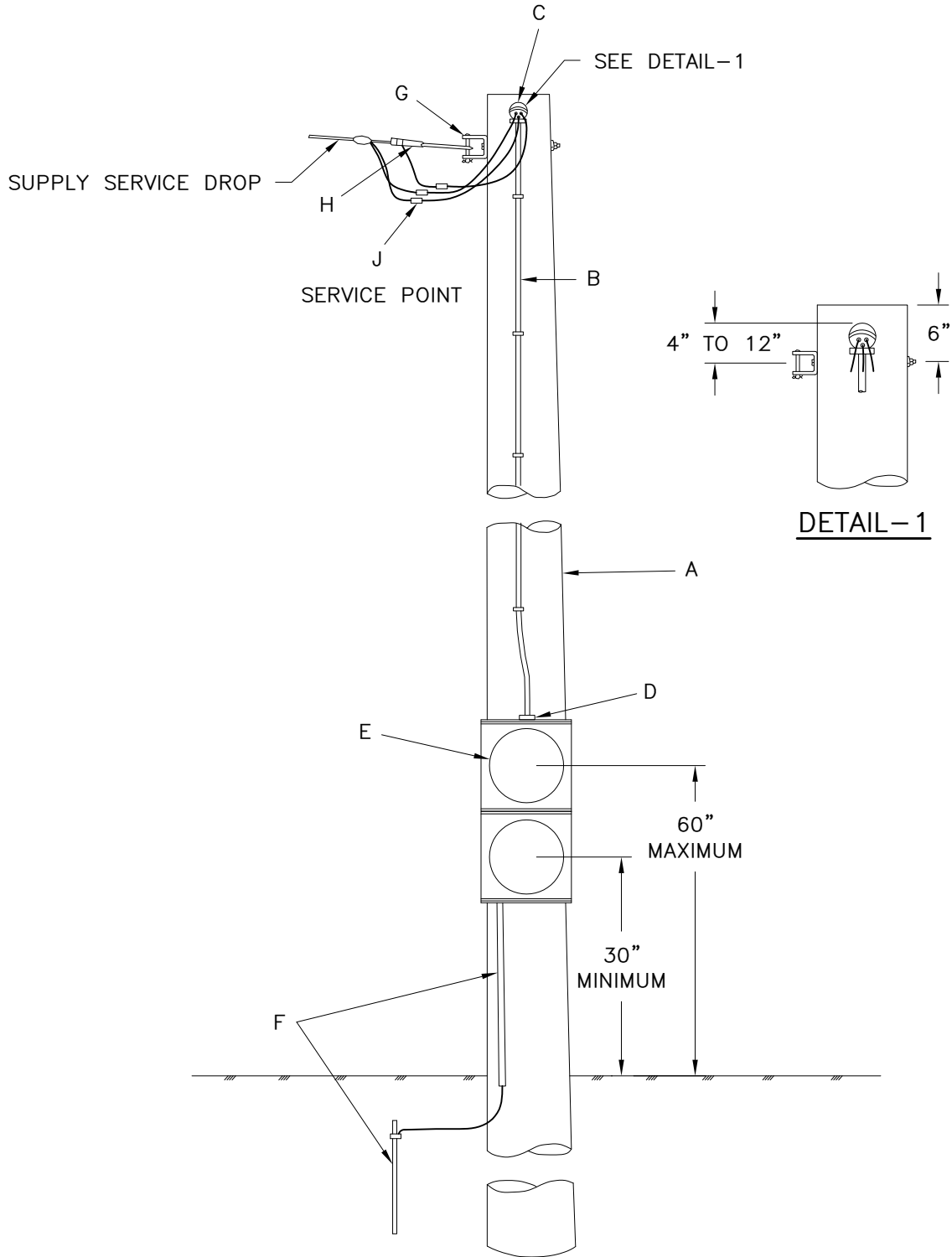

INSTALLATION OF CUSTOMER SERVICE POLE AND OUTDOOR METER CONNECTION DEVICE
 3-WIRE, 120/240V ONLY
 TRAILER PARK

CUSTOMER SERVICE POLE – OVHD TEMP SERVICE

OUTDOOR METER CONNECTION DEVICE

NOTES:

APPLICATION

- THIS STANDARD DESCRIBES THE REQUIREMENTS FOR THE INSTALLATION OF A CUSTOMER SERVICE POLE AND AN OUTDOOR METER CONNECTION DEVICE FOR OVERHEAD TEMPORARY SERVICE APPLICATIONS.

INFORMATION

1. CUSTOMER FURNISHES, INSTALLS, AND MAINTAINS THE FOLLOWING EQUIPMENT:

- A – TREATED POLE (MINIMUM REQUIREMENTS – CLASS #7, LENGTH, 25 FEET); OR A BRACED, 6" X 6" TIMBER OF AN APPROPRIATE LENGTH. BRACED 6" X 6" TIMBER IS NOT APPROVED FOR LOCATIONS AT WHICH PEOPLE CONGREGATE, SUCH AS PICNIC OR CARNIVAL GROUNDS.
- B – SERVICE HEAD. INSTALL ABOVE FORK BOLT AS SHOWN IN DETAIL-1. ALL NEW SERVICE HEADS SHALL BE LOCATED NO MORE THAN 25 FEET ABOVE THE GROUND, AND MUST BE POSITIONED SO THAT THE SERVICE WIRE INSTALLATION HAS SAFE ACCESS FROM AN EXTENSION LADDER.
- C – SERVICE ENTRANCE CABLE WITH CLAMPS SPACED AT A MAXIMUM OF THREE FEET, OR CONDUCTORS IN CONDUIT. ALLOW SUFFICIENT WIRE TO MAKE CONNECTION TO SERVICE DROP WIRE. WHEN CONDUIT IS USED, INSTALL METALLIC RIGID CONDUIT TO 10 FEET ABOVE GROUND LEVEL AND NONMETALLIC RIGID CONDUIT (WHERE USED) ABOVE 10 FEET.
- D – WEATHER-TIGHT CABLE CONNECTORS OR CONDUIT CONNECTORS.
- E – APPROVED METER CONNECTION DEVICE.
- F – LOCKABLE, WEATHER-TIGHT ENCLOSURE FOR DISCONNECTING MEANS.
- G – GROUND ROD, CONDUCTOR AND ASSOCIATED CONDUIT AND CLAMPS FOR GROUNDING METALLIC COMPONENTS.
- H – WHEN A 6" X 6" TIMBER IS USED, INSTALL 2" X 4" BRACES AND STAKES FASTENED BY 5/8" MACHINE BOLTS WITH TWO WASHERS AND TWO NUTS PER BRACE.
- J – FORK BOLT.

2. ComEd FURNISHES, INSTALLS, AND MAINTAINS THE FOLLOWING EQUIPMENT:

- K – SERVICE DROP DEAD-END.
- L – CONNECTORS FOR CONNECTING CUSTOMER'S WIRE TO SERVICE DROP. CUSTOMER TO NOTIFY ComEd OF CABLE SIZE.

3. ALL WORK PERFORMED AND EQUIPMENT PROVIDED BY ComEd WILL BE AT THE CUSTOMER'S EXPENSE.

4. CUSTOMER SHALL NOT MOVE OR TAMPER WITH TEMPORARY SERVICE FACILITIES AS LONG AS SERVICE IS ENERGIZED.

5. CUSTOMER IS RESPONSIBLE TO LOCK THE SERVICE DISCONNECT EQUIPMENT TO PROTECT PERSONS FROM CONTACT WITH ENERGIZED PARTS.

6. CUSTOMER SHALL NOTIFY ComEd PROMPTLY WHEN SERVICE IS NO LONGER REQUIRED.

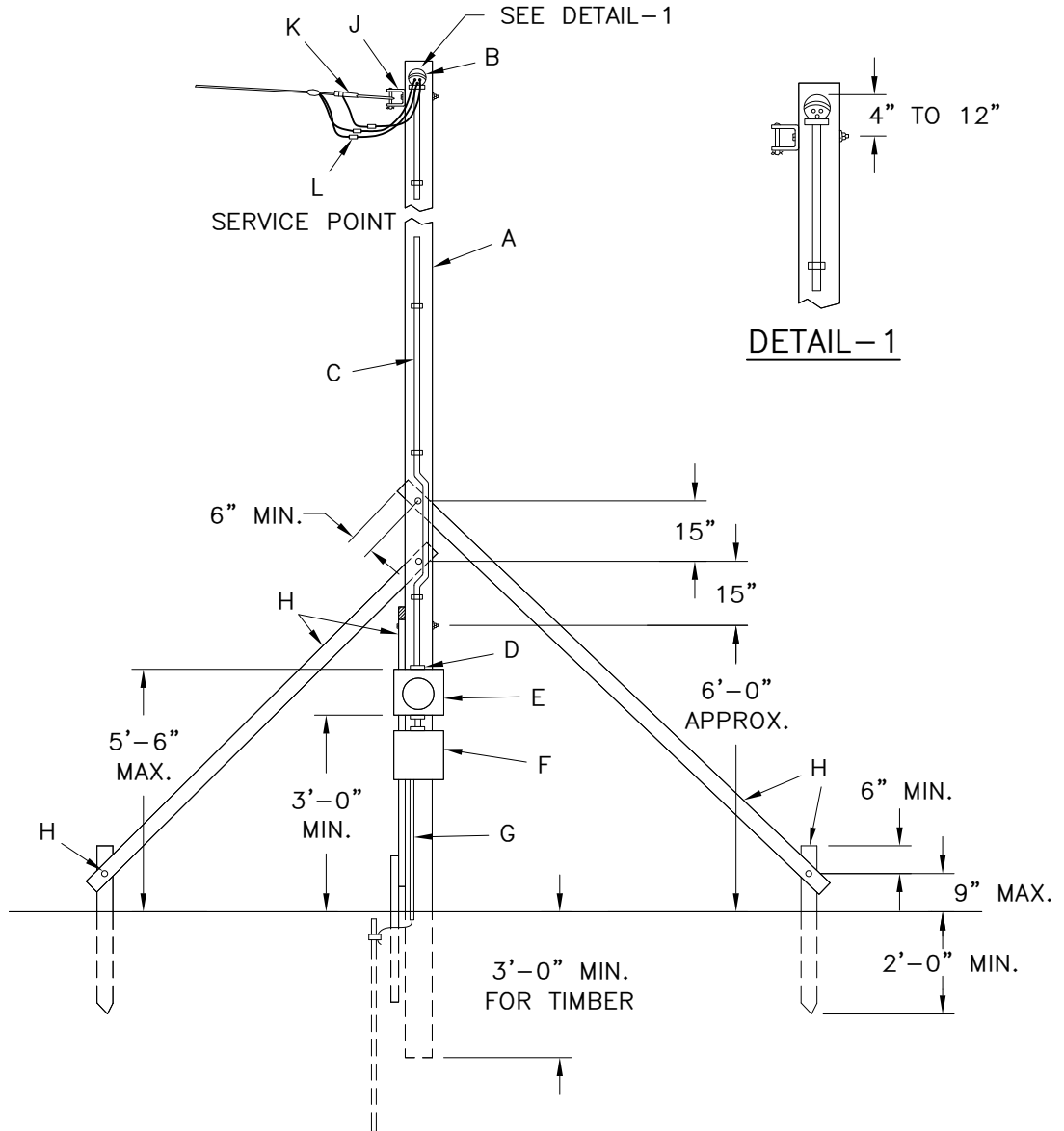
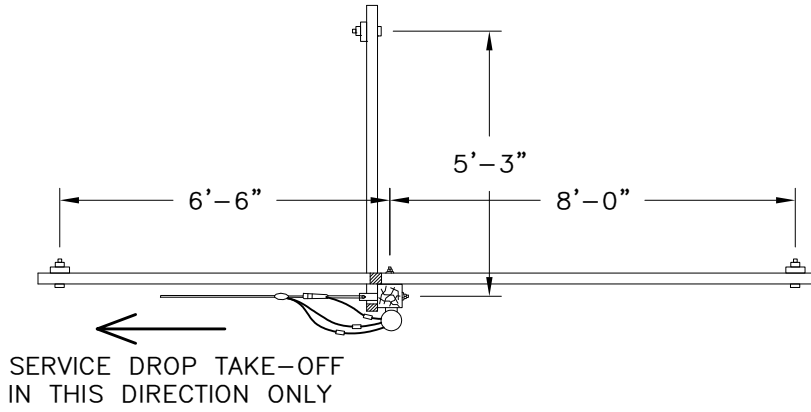

INSTALLATION OF CUSTOMER SERVICE POLE AND OUTDOOR METER CONNECTION DEVICE
TEMPORARY SERVICE

CUSTOMER UNDERGROUND TEMP SERVICE

OUTDOOR METER CONNECTION DEVICE

NOTES:

APPLICATION

- THIS STANDARD DESCRIBES THE REQUIREMENTS FOR THE INSTALLATION OF A CUSTOMER SERVICE SUPPORT, AND AN OUTDOOR METER CONNECTION DEVICE FOR TEMPORARY UNDERGROUND SERVICE APPLICATIONS.

INFORMATION

1. CUSTOMER FURNISHES, INSTALLS, AND MAINTAINS THE FOLLOWING EQUIPMENT:

- A – SERVICE SUPPORT. TREATED TIMBER – 4" X 4" X 8' (MINIMUM) TO BE SET A MINIMUM 3 FEET IN THE GROUND ON PRIVATE PROPERTY.
- B – APPROVED METER CONNECTION DEVICE.
- C – LOCKABLE, WEATHER-TIGHT ENCLOSURE FOR DISCONNECTING MEANS.
- D – GROUND ROD, CONDUCTOR AND ASSOCIATED CONDUIT AND CLAMPS PER LOCAL CODE.
- E – CONDUIT, SERVICE CONDUCTORS, INSULATED BUSHINGS, AND CONDUIT CLAMPS PER LOCAL CODE.
- F – SERVICE CABLE SIZED TO CONFORM TO LOCAL CODE REQUIREMENTS. CUSTOMER WILL DIRECT BURY CABLE AS SHOWN, BUT NOT CLOSER THAN 3 FEET FROM ComEd's TRANSFORMER PAD OR PEDESTAL. ANY CUSTOMER TRENCHING IN EASEMENT SHALL BE DONE AS DIRECTED BY ComEd. BEFORE DIGGING, CALL JULIE OR DIGGER AT LEAST 48 HOURS IN ADVANCE FOR CABLE LOCATING. SEAL CABLE ENDS FROM MOISTURE. MARK CABLE END LOCATION WITH AN EASILY IDENTIFIABLE STAKE. CUSTOMER TO PROVIDE AN ADDITIONAL 10 FEET OF CABLE FOR ComEd TO MAKE CONNECTIONS INSIDE THE TRANSFORMER OR PEDESTAL.

2. ComEd FURNISHES, INSTALLS, AND MAINTAINS THE FOLLOWING EQUIPMENT:

- G – ComEd SERVICE PEDESTAL OR TRANSFORMER LOCATED IN EASEMENT. ComEd WILL PROVIDE CONNECTORS FOR CUSTOMER'S CABLES AND CONNECT CABLES WITHIN ComEd's ENCLOSURE.

3. ALL WORK PERFORMED AND EQUIPMENT PROVIDED BY ComEd WILL BE AT THE CUSTOMER'S EXPENSE.

4. CUSTOMER SHALL NOT MOVE OR TAMPER WITH TEMPORARY SERVICE FACILITIES AS LONG AS SERVICE IS ENERGIZED.

5. SERVICE TRENCH MUST BE BACKFILLED WITH CLEAN MATERIAL.

6. CUSTOMER IS RESPONSIBLE TO LOCK THE SERVICE DISCONNECT EQUIPMENT TO PROTECT PERSONS FROM CONTACT WITH ENERGIZED PARTS.

7. CUSTOMER SHALL NOTIFY ComEd PROMPTLY WHEN SERVICE IS NO LONGER REQUIRED.

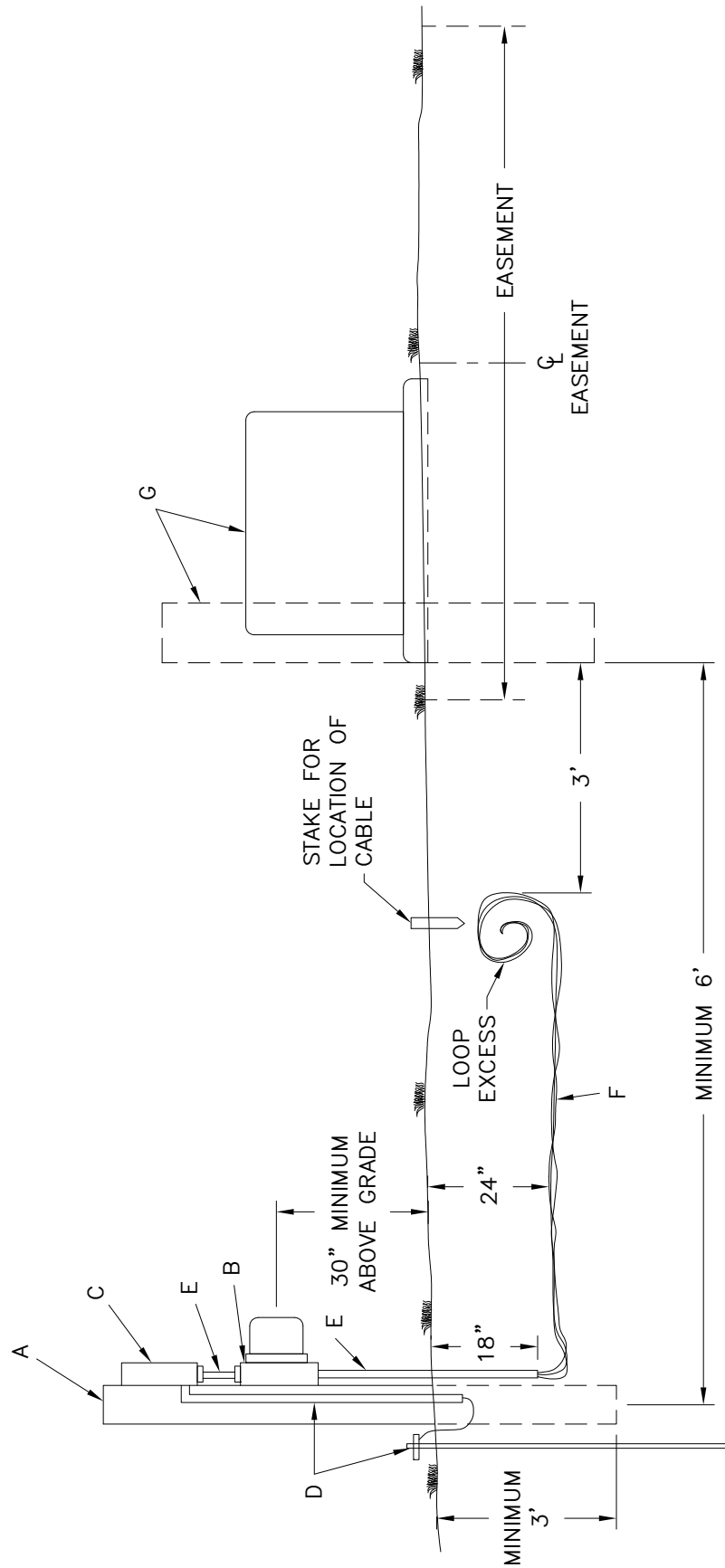

INSTALLATION OF CUSTOMER UNDERGROUND SERVICE AND OUTDOOR METER CONNECTION DEVICE -- TEMPORARY SERVICE

ACAD

CUSTOMER CABLE POLE TO OVHD SVC DROP

NOTES:

APPLICATION

- THIS STANDARD DESCRIBES THE REQUIREMENTS FOR INSTALLATION OF A CUSTOMER'S CABLE POLE WITH AN UNDERGROUND SECONDARY SERVICE CONNECTION TO A ComEd OVERHEAD SECONDARY SERVICE CONNECTION (SERVICE DROP).

INFORMATION

1 CUSTOMER FURNISHES, INSTALLS, AND MAINTAINS THE FOLLOWING EQUIPMENT IN ACCORDANCE WITH ComEd SPECIFICATIONS:

- A- TREATED POLE. (MINIMUM REQUIREMENTS - CLASS #7; LENGTH, 25 FEET). CUSTOMER SHALL CONSULT ANSI 05.1 MINIMUM SETTING DEPTH FOR CLASS AND LENGTH OF POLE INSTALLED. REFER TO ITEM "L" FOR MAXIMUM HEIGHT RESTRICTION.
- B- GALVANIZED RIGID METAL CONDUIT (BEND AND ONE 10-FOOT SECTION). THE CUSTOMER SHALL SPECIFY THE QUADRANT OF THE POLE IN WHICH THE CONDUIT SHALL BE INSTALLED.
- C- CONDUIT BUSHING (IF BURIED PORTION OF CABLE IS NOT IN DUCT).
- D- GALVANIZED CONDUIT STRAPS AND/OR LAG SCREWS AS REQUIRED.
- E- GROUND ROD, CONDUCTOR AND CLAMPS FOR GROUNDING METALLIC CONDUIT ON POLE.
- F- OUTDOOR ADAPTER COUPLING FOR METALLIC TO NONMETALLIC CONDUIT.
- G- NONMETALLIC RIGID CONDUIT.
- H- CABLE SUPPORT FOR CABLE LARGER THAN #4/0.
- J- CABLE, AND CONDUIT (IF INSTALLED). CABLE TO EXTEND FIVE FEET BEYOND CONDUIT RISER ON POLE. CUSTOMER TO NOTIFY ComEd OF CABLE SIZE.
- K- SEALING COMPOUND. IF DUCT OR CONDUIT ENTERS BUILDING, SPACE BETWEEN THE CABLE AND CONDUIT SHALL BE SEALED.
- L- SERVICE HEAD. ALL NEW SERVICE HEADS SHALL BE LOCATED NO MORE THAN 25' ABOVE THE GROUND, AND MUST BE POSITIONED SO THAT THE SERVICE WIRE INSTALLATION HAS SAFE ACCESS FROM AN EXTENSION LADDER.
- M- FORK BOLT.

2 ComEd FURNISHES, INSTALLS, AND MAINTAINS THE FOLLOWING EQUIPMENT:

- N- SERVICE DROP DEAD-END.
- P- CONNECTORS FOR CONNECTING CUSTOMER'S CABLE SERVICE DROP (SERVICE POINT).

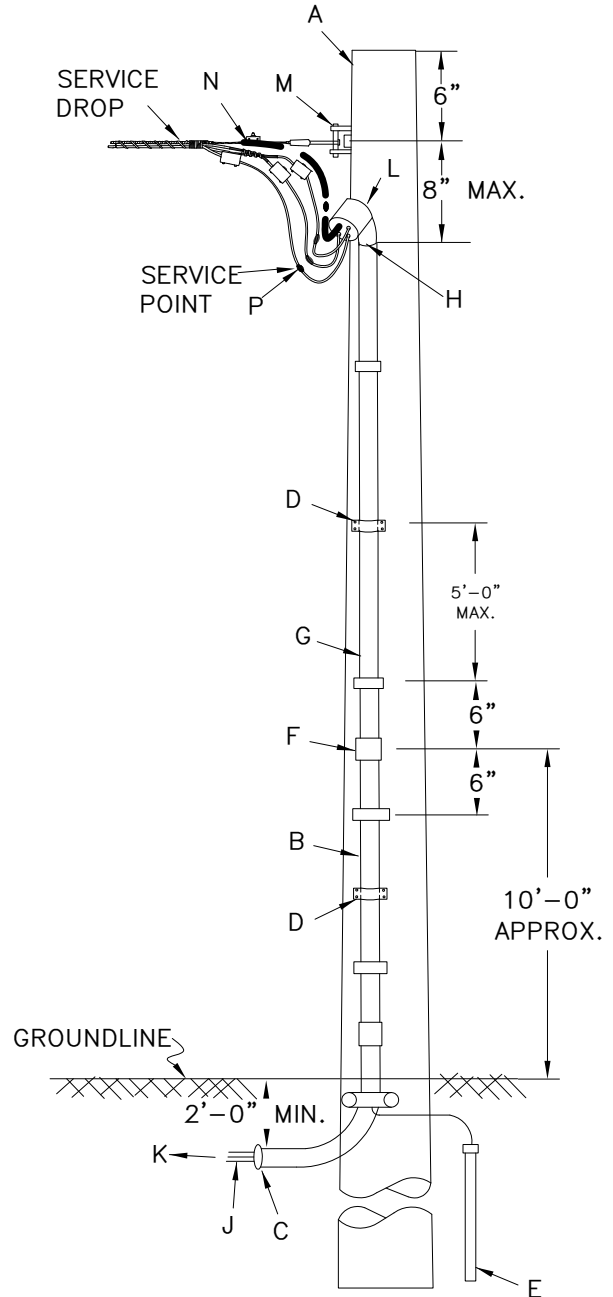

This page intentionally left blank

CUST UNDG SEC TO OVHD ESS

NOTES:

APPLICATION:

- THIS STANDARD DESCRIBES THE REQUIREMENTS TO CONNECT A CUSTOMER UNDERGROUND SECONDARY SERVICE TO AN OVERHEAD ELECTRIC SERVICE STATION (ESS). THE SERVICE POINT FOR THIS INSTALLATION IS THE SECONDARY TERMINALS OF THE TRANSFORMER.

INFORMATION:

- 1 CUSTOMER FURNISHES, INSTALLS AND MAINTAINS THE FOLLOWING EQUIPMENT ON THE ComEd POLE, IN ACCORDANCE WITH ComEd STANDARDS.
 - A – GALVANIZED RIGID METAL CONDUIT (BEND AND ONE 10-FOOT SECTION). ComEd TO SPECIFY THE QUADRANT OF THE POLE IN WHICH THE CONDUIT SHALL BE INSTALLED.
 - B – PROVISIONS FOR CONNECTION OF GROUND WIRE TO EACH CONDUIT BY ONE OF THE FOLLOWING METHODS
 1. CADWELD A 2-FOOT LENGTH OF #2 BARE TINNED COPPER CONDUCTOR (19-STRAND) TO THE CONDUIT PRIOR TO INSTALLING CABLE: OR
 2. PROVIDE GROUND CLAMP CONNECTORS (BURNDY TYPE "GAR" OR ComEd-APPROVED EQUIVALENT) TO ACCOMMODATE #2 BARE TINNED COPPER CONDUCTOR (19-STRAND).
 - C – GALVANIZED CONDUIT STRAPS AND LAG SCREWS OR, IF MULTIPLE SETS OF CONDUITS, MULTIPLE CONDUIT SUPPORT BRACKETS INSTALLED WITH $\frac{5}{8}$ " X 14" MACHINE BOLTS, $\frac{2}{4}$ " SQUARE FLAT WASHERS AND NUTS, AND MULTIPLE SUPPORT BRACKETS OR CONDUIT STRAP KITS (ALUMA-FORM BRACKET, PRODUCT #6-CSO-24 OR EQUIVALENT). REFER TO C7956.
 - D – OUTDOOR ADAPTER COUPLING FOR METALLIC TO NONMETALLIC CONDUIT. CONDUIT BUSHING TO BE INSTALLED IF U-GUARD IS USED ABOVE FIRST 10-FOOT SECTION.
 - E – CONDUIT BUSHING (IF BURIED PORTION OF CABLE IS NOT IN CONDUIT).
 - F – CABLE TO EXTEND AT LEAST 5 FEET BEYOND RISER ON POLE WITH SUFFICIENT SLACK TO CONNECT TO ComEd'S FACILITIES (SEE ITEM "M"). CUSTOMER TO INFORM ComEd OF CABLE SIZE.
 - G – NONMETALLIC RIGID CONDUIT OR U-GUARD. ComEd TO SPECIFY THE POINT ABOVE THE GROUND AT WHICH THE NONMETALLIC RIGID CONDUIT OR U-GUARD SHALL TERMINATE.
 - H – CONDUIT STRAPS, KITS, OR MULTIPLE-RISER BRACKETS (FOR SIZE AND TYPE SEE ITEM "C") OR LAG SCREWS.
 - J – NONMETALLIC CONDUIT COUPLING.
 - K – CABLE SUPPORT FOR CABLE LARGER THAN #4/0 AWG.
 - L – SEALING COMPOUND. IF CONDUIT ENTERS BUILDING, SPACE BETWEEN THE CABLE AND CONDUIT SHALL BE SEALED.
 - M – CABLE TERMINALS (2-HOLE NEMA SPADE LUGS) IF REQUIRED BY ComEd.
 - N – SERVICE HEAD. ALL NEW SERVICE HEADS SHALL BE LOCATED NO MORE THAN 25 FEET ABOVE THE GROUND, AND MUST BE POSITIONED SO THAT THE SERVICE WIRE INSTALLATION HAS SAFE ACCESS FROM AN EXTENSION LADDER.

INFORMATION (CONTINUED):

2 ComEd FURNISHES, INSTALLS, AND MAINTAINS THE FOLLOWING EQUIPMENT:

P – POLE (ELECTRIC SERVICE STATION SUPPORT).

Q – GROUND ROD FOR GROUNDING TRANSFORMER.

R – GROUNDING CONDUCTOR AND CONNECTION TO GROUND LEADS ON METALLIC CONDUIT OR CONNECTION TO GROUND CLAMP CONNECTOR.

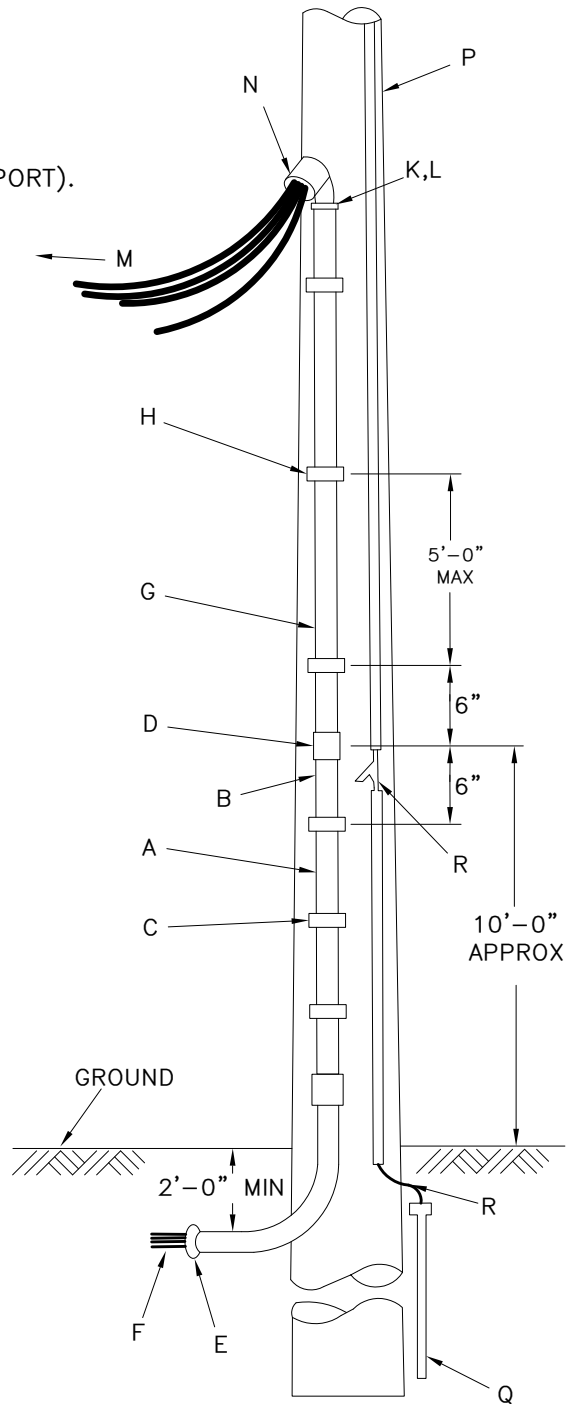

SINGLE CONDUIT RISER

ACAD

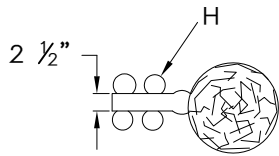

TOP VIEW

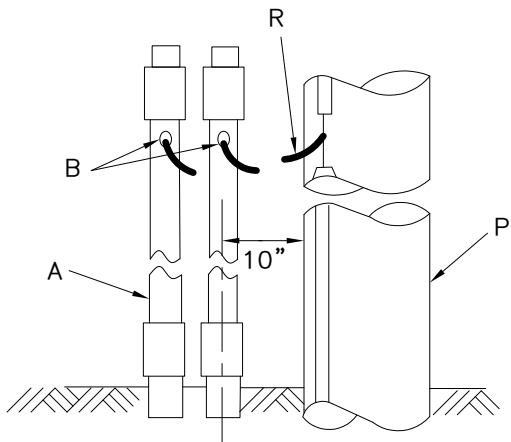

DETAIL-1

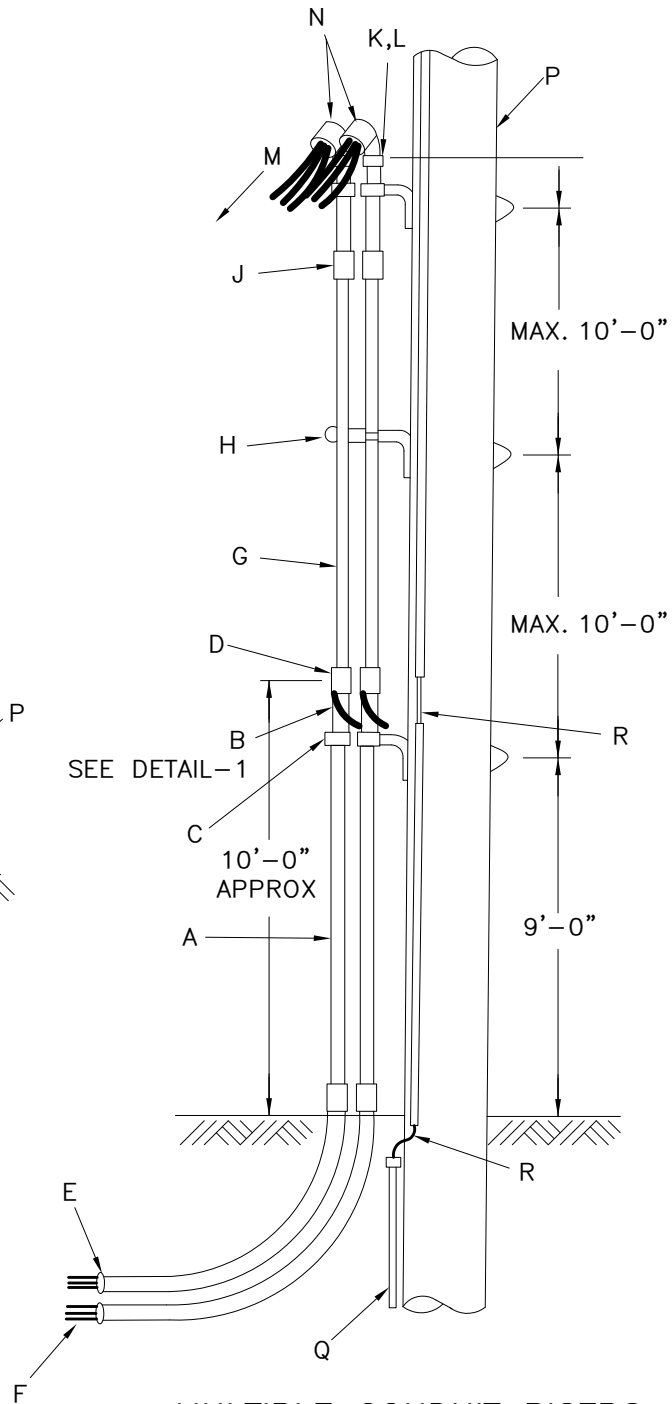

MULTIPLE CONDUIT RISERS

This page intentionally left blank

CUST OWNED LIGHTING ON COMED DIST POLE

NOTES:

APPLICATION:

- THIS STANDARD DESCRIBES REQUIREMENTS FOR INSTALLATION OF A CUSTOMER OWNED LIGHTING UNIT ON A ComEd DISTRIBUTION SYSTEM POLE.

INFORMATION:

- 1 A CUSTOMER-OWNED LIGHTING UNIT SERVED UNDER ComEd'S DUSK-TO-DAWN LIGHTING DELIVERY CLASS MAY BE INSTALLED BY A CUSTOMER QUALIFYING FOR SUCH SERVICE ON A ComEd DISTRIBUTION SYSTEM POLE, PROVIDED SUCH INSTALLATION IS CONSIDERED PRACTICABLE BY ComEd AND THE CUSTOMER PAYS THE COST OF ANY POLE OR SYSTEM REVISION THAT IS NECESSARY TO ACCOMMODATE THE LIGHTING UNIT. SUCH INSTALLATION SHALL NOT BE PERMITTED (a) ON A POLE ON WHICH A TRANSFORMER, CAPACITORS, A STREET OR ALLEY LIGHT, A CABLE RISER, OR OTHER MAJOR EQUIPMENT IS INSTALLED, OR (b) IF THE WEIGHT OF THE LIGHTING UNIT OR THE LENGTH OF THE MOUNTING BRACKET IS EXCESSIVE. ALSO, THE INSTALLATION MAY NOT BE PRACTICABLE ON AN EXISTING POLE BECAUSE THE AVAILABLE SPACE BETWEEN ComEd'S AND COMMUNICATION COMPANIES' FACILITIES IS NOT ADEQUATE TO PROVIDE PROPER CLEARANCES. IN THIS CASE, HOWEVER, IF THE CUSTOMER REQUESTS, AND IF THE CUSTOMER ARRANGES WITH THE COMMUNICATION COMPANIES FOR THE REVISION OF THEIR FACILITIES, ComEd WILL REVISE ITS FACILITIES TO PROVIDE SUCH CLEARANCES AT THE CUSTOMER'S EXPENSE.
- 2 THE CUSTOMER SHALL FURNISH, INSTALL AND MAINTAIN A LIGHTING UNIT, ONE PER POLE, WHICH OPERATES AT 120 VOLTS, WITH THE NECESSARY CONTROL, WIRES AND APPURTENANCES. THE LIGHTING UNIT INSTALLATION SHALL NOT EXCEED 560 FOOT-POUNDS, WHICH IS DETERMINED BY MULTIPLYING THE LENGTH OF THE BRACKET BY THE WEIGHT OF THE LUMINAIRE.
- 3 THE HEIGHT OF THE LOWEST PART OF THE LIGHTING INSTALLATION SHALL CONFORM TO ALL APPLICABLE CODES.
- 4 THE LIGHTING UNIT SHALL BE INSTALLED AND MAINTAINED BY QUALIFIED PERSONNEL UNDER THE SUPERVISION OF A SUPERVISING ELECTRICIAN OR ELECTRICAL CONTRACTOR.
- 5 IF A POLE UPON WHICH A LIGHTING UNIT IS INSTALLED REQUIRES REPLACEMENT, ComEd WILL, EXCEPT IN EMERGENCIES, NOTIFY THE CUSTOMER 48 HOURS BEFORE SUCH WORK IS SCHEDULED TO BEGIN, AND THE CUSTOMER WILL COORDINATE THE CUSTOMER'S WORK TO REMOVE AND RELOCATE SUCH LIGHTING UNIT WITH ComEd. IN THE EVENT THAT SUCH ADVANCE NOTICE CANNOT BE MADE OR THE CUSTOMER CANNOT MEET ComEd'S SCHEDULE, ComEd WILL LEAVE THE LIGHTING UNIT IN PLACE, TEMPORARILY CONNECT THE FIXTURE WIRES TO THE ComEd SUPPLY ON THE NEW POLE, CUT AWAY THE OLD POLE ABOVE AND BELOW THE FIXTURE SUPPORT AND LASH THE PORTION OF THE OLD POLE SUPPORTING THE FIXTURE TO THE NEW POLE. THE CUSTOMER SHALL WITHIN A REASONABLE LENGTH OF TIME, TRANSFER THE LIGHTING UNIT TO THE NEW POLE AND REMOVE THE LASHED PORTION OF THE OLD POLE. IF THE COMMUNICATION COMPANIES' FACILITIES ARE TO BE TRANSFERRED TO THE NEW POLE, THE CUSTOMER SHALL TRANSFER THE CUSTOMER'S FACILITIES PRIOR TO THE DAY ON WHICH THE COMMUNICATION COMPANY HAS SCHEDULED ITS WORK.

INFORMATION (CONTINUED):

⑥ INSTALLATION REQUIREMENTS:

THE LIGHTING UNIT SHALL BE INSTALLED IN THE POLE SPACE DESIGNATED BY ComEd. THE LUMINAIRE SHALL BE LOCATED SO THAT THE MOUNTING BRACKET IS PERPENDICULAR TO ComEd'S OVERHEAD DISTRIBUTION LINE, OR IF NECESSARY, NO MORE THAN 45 DEGREES FROM SUCH PERPENDICULAR.

FIGURE-1 ILLUSTRATES AND IDENTIFIES THE CLEARANCES THAT ARE REQUIRED BETWEEN THE LIGHTING UNIT AND THE EXISTING OR PROPOSED ELECTRICAL AND COMMUNICATION FACILITIES ON A POLE:

- A. CLEARANCE SHALL BE 12 INCHES MINIMUM FOR A DISTANCE OF FIVE FEET FROM THE FACE OF THE POLE.
- B. CLEARANCE SHALL BE 8 INCHES MINIMUM BETWEEN THE LUMINAIRE AND THE FACE OF THE POLE FOR A DISTANCE OF TWO FEET EXTENDING DOWNWARD FROM THE SPACE DESCRIBED ABOVE.
- C. CLEARANCE OF DRIP LOOPS SHALL BE A MINIMUM OF 12 INCHES FROM COMMUNICATION CABLES, OR A MINIMUM OF 24 INCHES IF THE COMMUNICATION CABLES ARE INSTALLED ON A CROSSARM.
- D. ComEd WILL SPECIFY FOR EACH POLE THE DISTANCE FROM THE GROUNDLINE TO THE BOTTOM OF THE ComEd SPACE AND THE TOP OF THE COMMUNICATION SPACE.

7 CUSTOMER FURNISHES, INSTALLS AND MAINTAINS THE FOLLOWING EQUIPMENT (SEE FIGURE-1 AND DETAIL "A")

- A - LUMINAIRE AND LAMP (NOT SHOWN).
- B - MOUNTING BRACKET FOR LAMP.
- C - HARDWARE REQUIRED TO MOUNT BRACKET WITH LAMP TO POLE, INCLUDING APPROPRIATE FASTENERS.
- D - SUPPLY SHALL BE TWO INSULATED #8 AWG WIRES (COPPER OR ALUMINUM), USING WHITE FOR NEUTRAL AND BLACK FOR PHASE. WIRES SHALL BE LONG ENOUGH FOR CONNECTION TO ComEd'S CONDUCTORS (ITEM "L") AND BE LEFT COILED AT THE BASE OF MOUNTING BRACKET (ITEM "B"). CUSTOMER SHALL CONNECT LINE AND LOAD WIRES TO SEPARATE CONTROL DEVICE (ITEM "H"), IF ANY.
- E - FUSE. A FUSED CONNECTOR (SUCH AS BUSSMANN, HEB, IDEAL-BUCHANAN SLK, FUSTEK ELASTIMOLD 65U) WITH CLASS CC FUSE IS APPROVED AS A DISCONNECTING MEANS FOR THE PHASE WIRE OF THE SUPPLY (ITEM "D"). THE FUSE DEVICE SHALL BE INSTALLED ON THE LINE SIDE OF THE CONTROL DEVICE (ITEM "H"), ABOVE THE DRIP LOOP AT A MINIMUM DISTANCE OF 12 INCHES FROM THE MOUNTING BRACKET (ITEM "B") AND THE CONTROL DEVICE (ITEM "H").
- F - DISCONNECTABLE GROUND CONNECTOR FOR GROUND WIRE (ITEM "G"), TO MOUNT GROUNDING.
- G - GROUND WIRE, AN INSULATED #6 AWG (COPPER OR ALUMINUM), GREEN IN COLOR. WIRE SHALL BE CONNECTED TO DISCONNECTABLE GROUND CONNECTOR (ITEM "F"), AND BE ADEQUATE IN LENGTH FOR CONNECTION TO ITEM "L". WIRE SHALL BE LEFT COILED AT BASE OF MOUNTING BRACKET (ITEM "B").
- H - CONTROL DEVICE. PHOTOELECTRIC CELL MAY BE PART OF LUMINAIRE OR SEPARATELY MOUNTED ON POLE (SEE DETAIL-A). IF CONTROL DEVICE IS SEPARATE, CUSTOMER SHALL CONNECT LINE AND LOAD WIRES AS DESCRIBED IN ITEM "D".
- J - IDENTIFICATION TAPE. RED RETROREFLECTIVE, WEATHER-RESISTANT TAPE WRAPPED AROUND MOUNTING BRACKET (ITEM "B") ADJACENT TO THE LUMINAIRE. WRAPPING SHALL BE 6 INCHES WIDE, AND MUST BE VISIBLE FROM THE GROUND.

INFORMATION (CONTINUED):

8 ComEd FURNISHES, INSTALLS AND MAINTAINS, SUBJECT TO THE PROVISIONS OF THE GENERAL TERMS AND CONDITIONS APPLICABLE TO THE DUSK-TO-DAWN LIGHTING AND GENERAL LIGHTING DELIVERY CLASSES:

K - DISTRIBUTION SYSTEM POLE.

L - 120 VOLT CIRCUIT.

M - PLASTIC MOLDING AND FASTENERS.

N - CONNECTORS FOR CONNECTION OF SUPPLY WIRES (ITEM "D") AND GROUND WIRE (ITEM "G") TO ComEd'S SUPPLY.

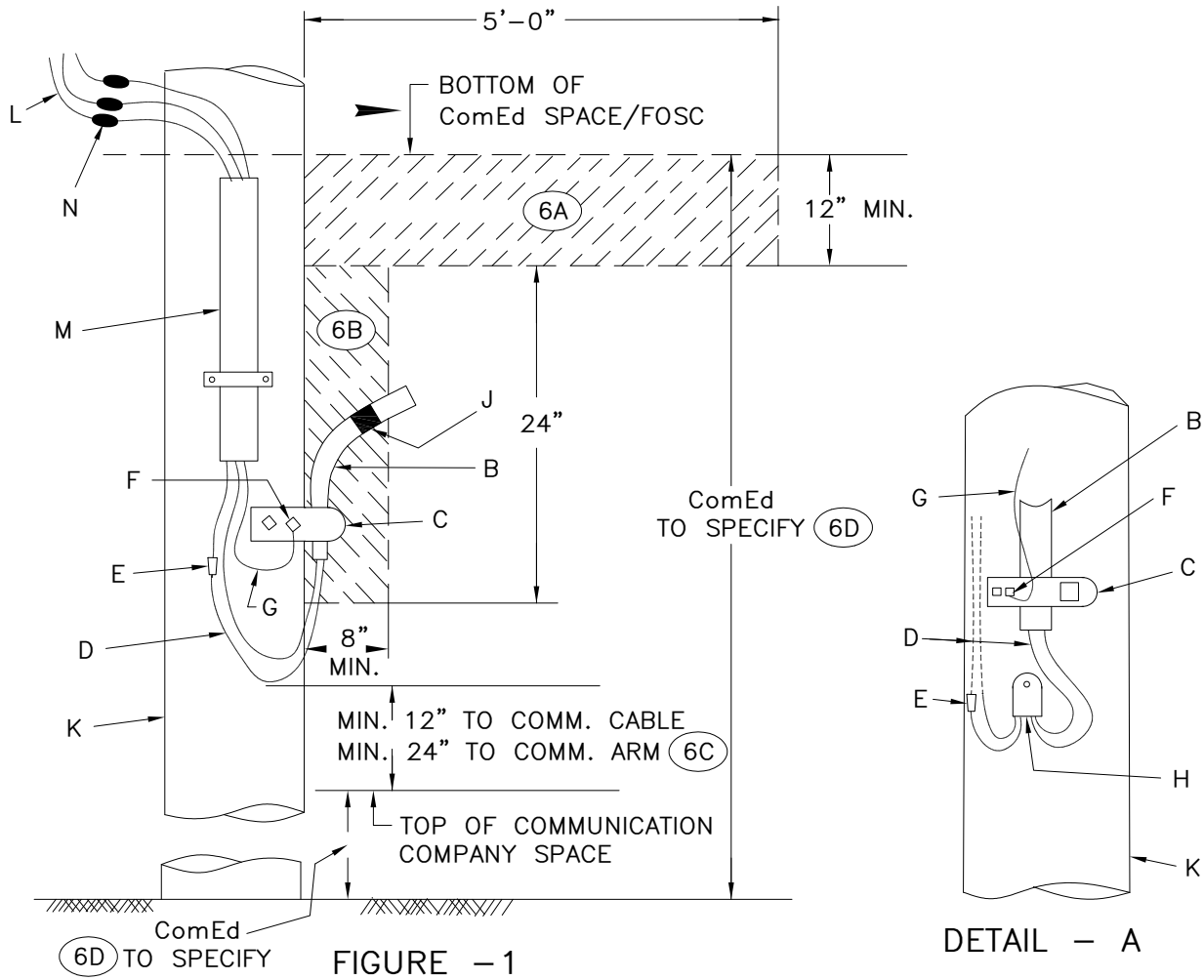

This page intentionally left blank

TRAFFIC SIGNAL/STREET LT SVC CONN/OVHD TRANSMITTER CONNECTIONS OVERHEAD TO UNDERGROUND SERVICE

NOTES:

APPLICATION

- THIS STANDARD DESCRIBES REQUIREMENTS FOR CUSTOMER OVERHEAD CONNECTION OF TRAFFIC SIGNALS, STREET LIGHTING, AND CTA TRANSMITTERS TO A ComEd UNDERGROUND SERVICE.

INFORMATION

1 CUSTOMER FURNISHES, INSTALLS AND MAINTAINS THE FOLLOWING EQUIPMENT:

- A- CABLE.
- B- CONDUIT BUSHING, IF BURIED PORTION OF CABLE IS NOT IN DUCT.
- C- GROUND ROD, CONDUCTOR, AND ASSOCIATED CONDUIT AND CLAMPS FOR GROUNDING METALLIC COMPONENTS.
- D- GALVANIZED RIGID METAL CONDUIT WITH BEND.
- E- GALVANIZED CONDUIT STRAPS.
- F- JUNCTION BOX. A WEATHER-TIGHT, LOCKABLE, GALVANIZED BOX FOR CONTROL DEVICE AND DISCONNECTING MEANS OR AN APPROVED CONDULET OR EQUIVALENT FOR DISCONNECTING MEANS IF CONTROL DEVICE OR DISCONNECTING MEANS IS INSTALLED ON ComEd POLE. JUNCTION BOX SHOULD BE INSTALLED FACING THE ADJACENT PROPERTY LINE. SEE SECTION A-A FOR ALTERNATE INSTALLATION POSITIONS.
- G- GROUND STUD FOR NEUTRAL CONNECTION, USED WHEN OVERCURRENT DEVICE IS INSTALLED.
- H- SERVICE CABLES. ComEd TO SPECIFY LENGTH OF CABLES. CUSTOMER TO CONNECT CABLES IN JUNCTION BOX AND COIL EXCESS CABLE AT JUNCTION BOX. ComEd TO INSTALL CABLES ABOVE JUNCTION BOX AND CONNECT TO OVERHEAD LINE.
- J- WEATHER-TIGHT CONNECTOR AND CONDUIT ATTACHED TO POLE TO ACCOMMODATE U-GUARD. THE CONDUIT SHALL BE SEALED WITH A SEALANT APPROPRIATE FOR USE NEAR ELECTRICAL EQUIPMENT.
- K- OVERCURRENT DEVICE OR DISCONNECTING MEANS.

2 ComEd FURNISHES, INSTALLS AND MAINTAINS THE FOLLOWING EQUIPMENT:

- L- U-GUARD TO ENCLOSE SERVICE CABLES ABOVE JUNCTION BOX, ITEM "F".

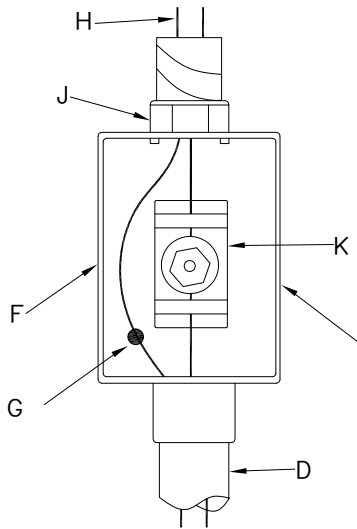

JUNCTION BOX

MAX. DIMENSIONS
 18" HIGH
 9" WIDE
 8" DEEP

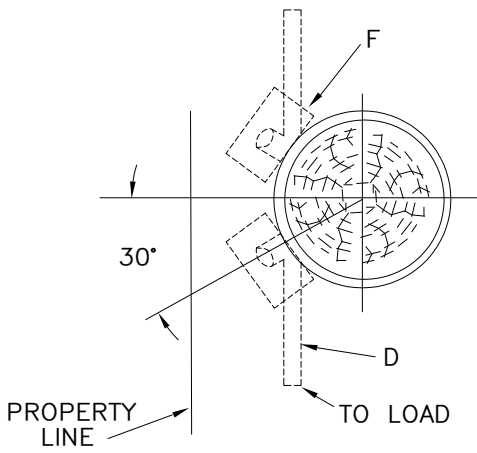

SECTION A-A

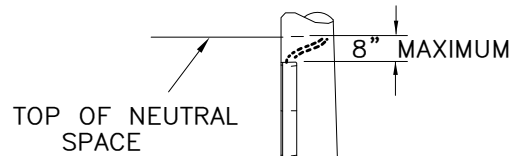

10'-0" MINIMUM

MAXIMUM
11'-0"
MINIMUM
5'-0"

CUSTOMER-OWNED UNDERGROUND
SECONDARY TO ComEd OVERHEAD

TRAFFIC SIGNAL/ STREET LT SVC CONN/UNDG TRANSMITTER CONNECTIONS UNDERGROUND SERVICE

NOTES:

APPLICATION

- THIS STANDARD DESCRIBES REQUIREMENTS FOR CUSTOMER UNDERGROUND CONNECTION OF TRAFFIC SIGNALS, STREET LIGHTING, AND CTA TRANSMITTERS TO A ComEd UNDERGROUND SERVICE.

INFORMATION

1 CUSTOMER FURNISHES, INSTALLS AND MAINTAINS THE FOLLOWING EQUIPMENT:

- A- ABOVE GROUND ENCLOSURE FOR FUSED WIRE CONNECTOR, ITEM "B". THIS ENCLOSURE SHALL BE EITHER A SERVICE PEDESTAL COMPARTMENT WITH PROVISIONS FOR LOCKING WITH A CUSTOMER'S LOCK OR A HANDHOLE LOCATED IN FIRST POLE OF A GROUP OF STREET LIGHTS. CUSTOMER ENCLOSURE SHALL BE LOCATED OUTSIDE OF ComEd EASEMENT.
- B- FUSED WIRE CONNECTOR - APPROVED AS A DISCONNECTING MEANS IF THE SERVICE VOLTAGE IS 240 VOLTS OR LOWER. THIS DEVICE SHALL BE INSTALLED ABOVE GROUND ONLY, AND WITHIN THE CUSTOMER OWNED ENCLOSURE, ITEM "A". REFER TO TABLE-1 FOR A LIST OF FUSED WIRE CONNECTORS APPROVED AS DISCONNECTING MEANS.
- C- TRENCH DEPTH TO BE 24" BELOW FINAL GRADE AND TERMINATED THREE FEET FROM THE ComEd ENCLOSURE, ITEM "G". ANY CUSTOMER TRENCHING IN ComEd EASEMENT SHALL BE DONE AS DIRECTED BY ComEd. BEFORE DIGGING, CONTACT JULIE FOR SUBURBAN LOCATIONS OR DIGGER FOR CHICAGO, AT LEAST 48 HOURS IN ADVANCE FOR UNDERGROUND UTILITY LOCATING.
- D- SERVICE CABLE. THE CUSTOMER SHALL EXTEND THE CUSTOMER'S CABLE TO THE ComEd DISTRIBUTION SYSTEM. THE CABLE SHALL BE SUITABLE FOR DIRECT BURIAL INSTALLATION IN A WET LOCATION. CUSTOMER TO PROVIDE AN ADDITIONAL 10 FT. OF CABLE FOR CONNECTION TO THE ComEd SYSTEM COILED AT THE END OF THE CUSTOMER'S TRENCH WITH MOISTURE-SEALED ENDS. CABLE SIZE TO BE A MINIMUM OF #6 AND A MAXIMUM OF #2. NEUTRAL CABLE TO BE CONNECTED TO GROUND STUD, ITEM "E", IN CUSTOMER ENCLOSURE, ITEM "A".

E- UNINSULATED GROUND STUD FOR CONNECTION OF NEUTRAL AND GROUND CONDUCTOR IN CUSTOMER ENCLOSURE, ITEM "A".

F- GROUND ROD AND CONDUCTOR CONNECTED TO GROUND STUD, ITEM "E".

2 ComEd FURNISHES, INSTALLS AND MAINTAINS THE FOLLOWING EQUIPMENT:

G- ComEd-OWNED SERVICE PEDESTAL OR TRANSFORMER LOCATED IN EASEMENT. ComEd WILL PROVIDE CONNECTORS FOR CABLES AND CONNECT CABLES WITHIN THE ComEd OWNED ENCLOSURE. ComEd WILL IDENTIFY CUSTOMER'S STREET LIGHT CABLE. IF A SERVICE PEDESTAL OR TRANSFORMER IS REQUIRED SOLELY TO SUPPLY THE CUSTOMER, THE SERVICE PEDESTAL OR TRANSFORMER AND EXTENSION OF THE ComEd LINES TO THE SERVICE PEDESTAL OR TRANSFORMER WILL BE PROVIDED AT THE CUSTOMER'S EXPENSE.

APPROVED MANUFACTURER	STYLE*	FUSE SIZE RANGE	CONNECTS FOLLOWING RANGE OF CONDUCTOR SIZES
BUSSMAN	HEB**	0.1 TO 30 AMPERES	#12 TO #2
FUSETEK-ELASTIMOLD	65U	0.1 TO 30 AMPERES	#14 TO #6
IDEAL-BUCHANAN	SLK	0.1 TO 30 AMPERES	#14 TO #2

* OTHER STYLES ARE ALSO AVAILABLE FOR "Y" CONNECTIONS
 ** ADDITIONAL SUFFIXES ARE ASSOCIATED WITH THE SIZE AND TYPE OF LOAD AND SOURCE CONDUCTORS. THIS ADDITIONAL INFORMATION MAY BE SECURED FROM THE DISTRIBUTOR

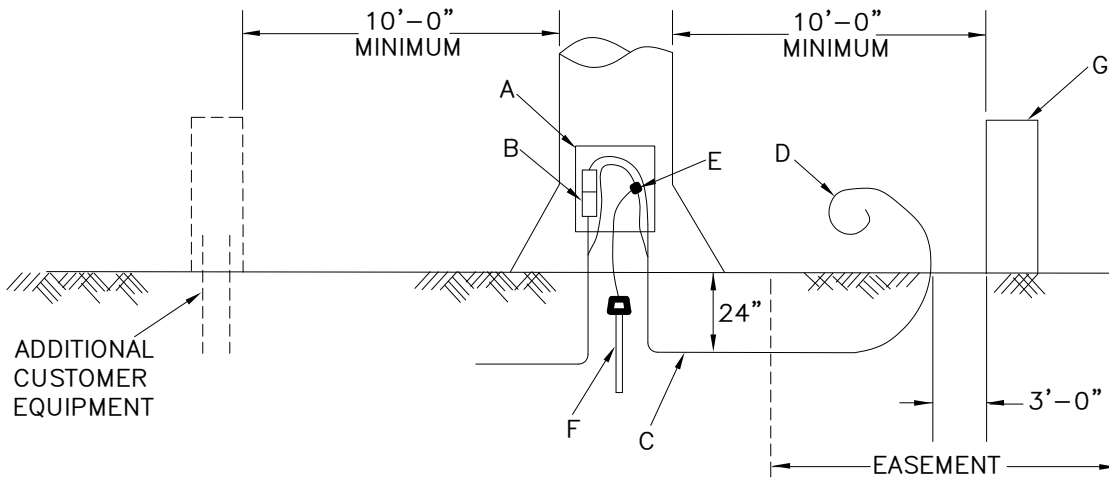

This page intentionally left blank

COMM POWER SUPPLY SERVICE – OVHD

NOTES:

APPLICATION

- THIS STANDARD DESCRIBES THE REQUIREMENTS FOR THE INSTALLATION OF AN OVERHEAD SECONDARY SERVICE CONNECTION TO A COMMUNICATION COMPANY POWER SUPPLY CABINET. COMMUNICATION (COMM) MAY INCLUDE, BUT ARE NOT LIMITED TO, COMPANIES SUCH AS CABLE TELEVISION, FIBER OPTICS AND COMMUNICATION COMPANIES OTHER THAN THE LOCAL TELEPHONE COMPANY.

INFORMATION

1. COMM FURNISHES, INSTALLS, AND MAINTAINS THE FOLLOWING EQUIPMENT ON ComEd's POLE:
 - A – COMM POWER SUPPLY CABINET WITH OVERCURRENT DEVICE AND DISCONNECTING MEANS. WHEN SUSPENDED TELCO TERMINAL IS PRESENT, LOCATE CABINET ON THE OPPOSITE SIDE OF POLE FROM TELCO TERMINAL.
 - B – SERVICE CABLE (600 VOLT SINGLE OR MULTIPLE CONDUCTOR CABLE SUITABLE FOR WET LOCATIONS). MINIMUM CONDUCTOR SIZE IS #6 SOLID ALUMINUM OR COPPER. ComEd TO SPECIFY LENGTH OF CABLES. COMM TO CONNECT CABLES IN POWER SUPPLY CABINET AND COIL EXCESS CABLE AT CABINET. ComEd TO INSTALL SERVICE CABLES ABOVE POWER SUPPLY CABINET AND CONNECT TO OVERHEAD LINE.
 - C – GROUNDING CONDUCTOR. CONDUCTOR TO BE #6 SOFT DRAWN WEATHER-RESISTANT COPPER. CUSTOMER TO CONNECT TO (a) POWER SUPPLY CABINET AND (b) THE MESSENGER OF THE COMM CABLE. PROVIDE SUFFICIENT LENGTH FOR ComEd TO CONNECT EACH GROUNDING CONDUCTOR TO ComEd'S VERTICAL GROUND WIRE.
2. COMM SHALL NOT INSTALL POWER SUPPLY OR OTHER POLE MOUNTED EQUIPMENT CABINETS ON POLES WITH EXISTING:
 - CORNER POLES
 - GANG-OPERATED SWITCHES WITH BASE MOUNTED SWITCH HANDLES
 - CONTROL CABINETS, SUCH AS THOSE ASSOCIATED WITH REGULATORS, CAPACITORS, RECLOSERS, AND AUTOMATED SWITCHES
 - PRIMARY VOLTAGE CABLE RISER POLES
 - TRANSFORMERS
 - METER COLLECTOR CABINETS
 - CATHODIC PROTECTION RECTIFIERS
 - TELCO POLE-MOUNTED TERMINALS

ADDITIONALLY, COMM SHALL NOT INSTALL POWER SUPPLY ON JOINTLY OWNED POLES OVER THE OBJECTION OF TELCO, OR IF ComEd DETERMINES THE ADDITION WOULD RESTRICT THE REQUIRED CLIMBING SPACE OR CREATE A SAFETY HAZARD.

3. THE COMM SYSTEM SHALL BE DESIGNED IN SUCH A WAY THAT NO POWER SUPPLY CAN BE ELECTRICALLY BACKFED FROM ANOTHER POWER SUPPLY THROUGH THE COMM SYSTEM.

4. ComEd FURNISHES, INSTALLS, AND MAINTAINS THE FOLLOWING EQUIPMENT AT CUSTOMER'S EXPENSE:

D – GROUNDING WIRE WITH ASSOCIATED CONNECTORS AND MOLDING OR "U" GUARD FROM ComEd's SECONDARY NEUTRAL TO GROUND ROD.

E – GROUND ROD.

F – CONNECTORS FOR CONNECTING CUSTOMER'S GROUNDING CONDUCTORS TO ComEd's VERTICAL GROUND WIRE.

5. ComEd FURNISHES, INSTALLS, AND MAINTAINS THE FOLLOWING EQUIPMENT:

G – MOLDING OR "U" GUARD TO ENCLOSE CUSTOMER'S SUPPLY CABLES.

H – CONNECTORS FOR CONNECTING COMM's POWER SUPPLY CABLES TO ComEd's SECONDARY CONDUCTORS.

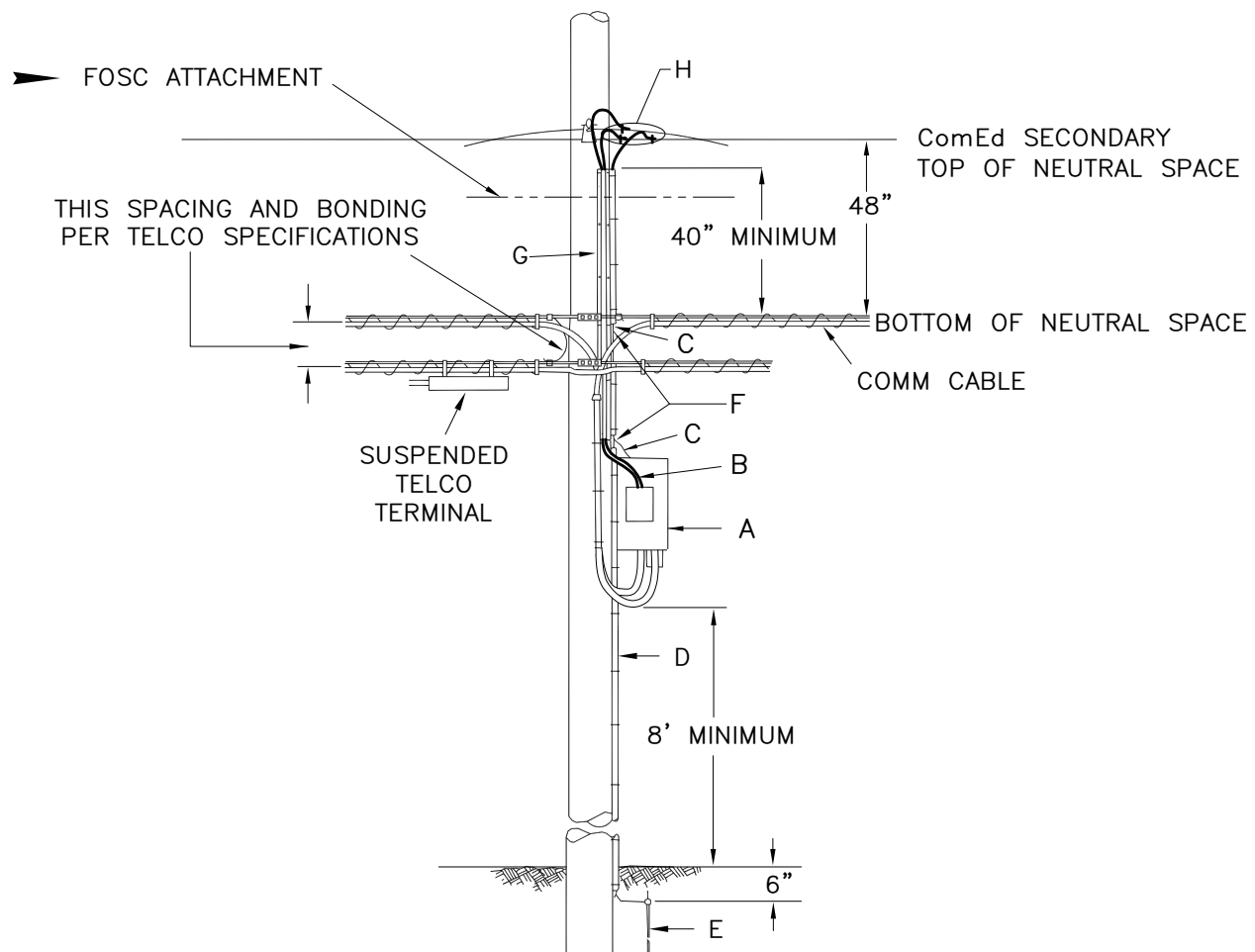

**COMM POWER SUPPLY SERVICE
SERVICE FROM OVERHEAD FACILITIES**

ACAD

COMM POWER SUPPLY SERVICE – UNDG

NOTES:

APPLICATION

- THIS STANDARD DESCRIBES THE REQUIREMENTS FOR THE INSTALLATION OF AN UNDERGROUND SECONDARY SERVICE CONNECTION TO A COMMUNICATION COMPANY POWER SUPPLY CABINET. COMMUNICATION (COMM) MAY INCLUDE, BUT ARE NOT LIMITED TO, COMPANIES SUCH AS CABLE TELEVISION, FIBER OPTICS AND COMMUNICATION COMPANIES OTHER THAN THE LOCAL TELEPHONE COMPANY.

INFORMATION

1. COMM FURNISHES, INSTALLS, AND MAINTAINS THE FOLLOWING EQUIPMENT IN THE UTILITY EASEMENT OR ON PUBLIC RIGHT-OF-WAY:
 - A – COMM POWER SUPPLY CABINET WITH OVERCURRENT AND DISCONNECT MEANS MOUNTED ON A SUPPORT POST. THE LOCATION OF THE SUPPORT POST TO BE SPECIFIED BY ComEd.
 - B – TRENCH DEPTH TO BE 24" BELOW FINAL GRADE AND TERMINATED 3 FEET FROM ComEd ENCLOSURE. ANY COMM TRENCHING IN EASEMENT SHALL BE DONE AS DIRECTED BY ComEd. BEFORE DIGGING, CALL JULIE OR DIGGER AT LEAST 48 HOURS IN ADVANCE FOR CABLE LOCATING.
 - C – SERVICE CABLE (600 VOLT SINGLE OR MULTIPLE-CONDUCTOR CABLE SUITABLE FOR DIRECT BURIAL INSTALLATION). THE COMM SHALL EXTEND ITS OWN CABLE TO ComEd's DISTRIBUTION SYSTEM. COMM TO PROVIDE AN ADDITIONAL 10 FEET OF CABLE WITH MOISTURE SEALED ENDS, COILED AT END OF COMM'S TRENCH FOR CONNECTION TO ComEd's SYSTEM. CABLE SIZE TO BE A MINIMUM OF #6 AND A MAXIMUM OF #2. NEUTRAL CABLE TO BE CONNECTED TO GROUNDING STUD IN COMM'S POWER SUPPLY CABINET.
 - D – UNINSULATED GROUND STUD FOR CONNECTION OF NEUTRAL AND GROUND CONDUCTOR IN COMM'S POWER SUPPLY CABINET.
 - E – GROUND ROD AND CONDUCTOR CONNECTED TO GROUND STUD.
2. ComEd FURNISHES, INSTALLS, AND MAINTAINS THE FOLLOWING EQUIPMENT:
 - F – ComEd OWNED SERVICE PEDESTAL OR TRANSFORMER LOCATED IN EASEMENT.
 - G – CONNECTORS FOR CONNECTING COMM'S CABLES WITHIN ComEd ENCLOSURE.

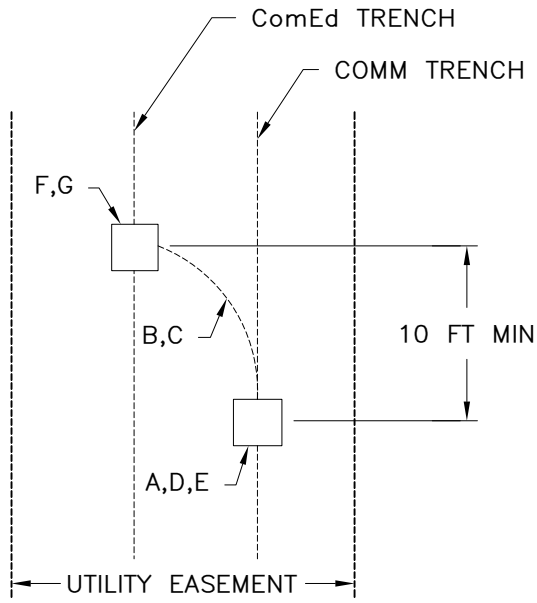

PLAN

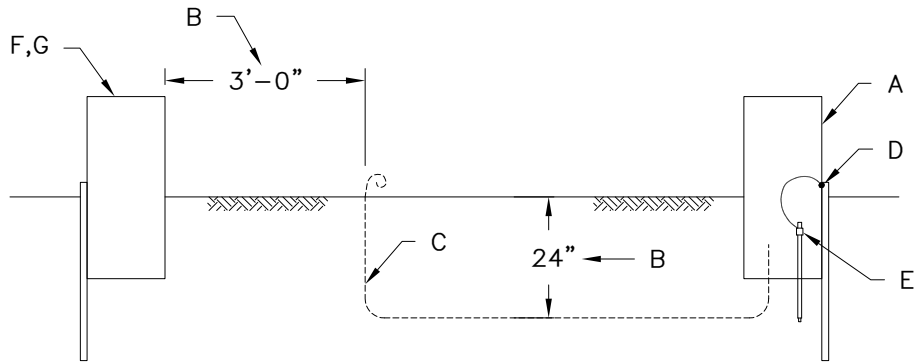

PROFILE

COMM POWER SUPPLY SERVICE
 SERVICE FROM UNDERGROUND FACILITIES

METERING – GENERAL REQUIREMENTS

NOTES:

APPLICATION

- THIS STANDARD DESCRIBES THE GENERAL REQUIREMENTS FOR METERING INSTALLATIONS.

GENERAL

IT IS NECESSARY THAT EACH RETAIL CUSTOMER LOCATED IN THE COMPANY’S SERVICE TERRITORY IS PROVIDED WITH SEPARATE METER-RELATED FACILITIES AND DESIGNATED AS A SEPARATE RETAIL CUSTOMER PER GENERAL TERMS AND CONDITIONS (GT&C).

METER CONNECTION DEVICES

ONLY METER CONNECTION DEVICES MARKED OR LABELED BY THE MANUFACTURER WITH THE LETTERS "CECHA" ARE APPROVED FOR USE IN THE ComEd SERVICE AREA. THE MANUFACTURER’S LABEL MUST ALSO INCLUDE INFORMATION THAT:

1. THE DEVICE IS SUITABLE FOR OUTDOOR USE. IF NOT DESIGNATED, THE DEVICE IS SUITABLE FOR INDOOR USE ONLY.
2. SHOWS RATED CAPACITY OR CROSS SECTIONAL AREA OF THE MANUFACTURER INSTALLED BUS OF A GROUPED METER SOCKET ASSEMBLY.

METER CONNECTION DEVICES NOT BEARING THE LETTERS "CECHA" SHALL NOT BE INSTALLED WITHOUT SPECIFIC ComEd APPROVAL.

APPROVED FASTENERS FOR WALL MOUNTING OF METER DEVICES AND MOUNTING BOARDS:

Location	WALL MATERIAL				
	Solid Masonry or Concrete	Hollow Masonry	Wood	Stucco or Composition	Plaster
Outdoor	Expansion Bolts	Toggle Bolts	Toggle Bolts	Toggle Bolts	-----
Indoor	Expansion Bolts	Toggle Bolts	Wood or Lag Screws	-----	Toggle Bolts

MOUNTING BOARDS

WHEN INDOOR METER CONNECTION DEVICES CANNOT BE MOUNTED DIRECTLY ON AN EVEN SURFACE IN A PLUMB POSITION, THE CUSTOMER SHALL PROVIDE AND INSTALL A MOUNTING BOARD FOR ALL INDOOR INSTALLATIONS OF SINGLE OR MULTIPLE POSITION METER CONNECTION DEVICES.

THE MOUNTING BOARD SHALL BE 6" WIDER AND 6" HIGHER (3" ON EACH SIDE AND 3" ON TOP AND BOTTOM) THAN OUTSIDE DIMENSIONS OF SINGLE POSITION METERING FACILITIES, OR GROUPED FACILITIES MOUNTED AT THE SPECIFIC LOCATION.

THE BOARD SHALL BE 1" SOLID LUMBER OR 3/4" EXTERIOR GRADE PLYWOOD ATTACHED TO VERTICAL FURRING STRIPS. MOUNTING HEIGHT IS DICTATED BY SPECIFICATION OF THE METER INSTALLATION.

SECURING OF METER CONNECTION DEVICES

UPON ORIGINAL INSTALLATION, THE COVER(S) MUST BE IN PLACE AND SECURED AND THE METER SOCKET OPENING MUST BE COVERED AND SECURED. AT NO TIME SHALL ANY METER CONNECTION DEVICE, ENERGIZED OR NOT, BE LEFT UNSECURED.

SELF-CONTAINED METERS

MANUAL BY-PASS PROVISION:

ALL METER CONNECTION DEVICES (RESIDENTIAL AND COMMERCIAL) SHALL INCLUDE BY-PASS PROVISIONS SO THAT SERVICE NEED NOT BE INTERRUPTED WHEN A METER IS REMOVED.

GROUPING OF METERS:

MULTIPLE-POSITION DEVICES, 2 THROUGH 6 POSITION, SHOULD BE USED FOR BOTH INDOOR AND OUTDOOR INSTALLATIONS. GROUPED DEVICES SHALL BE MOUNTED ON MOUNTING BOARDS PER REQUIREMENTS NOTED IN THIS SECTION AND RELATED WIRING LAYOUTS.

GROUNDING

METER CONNECTION DEVICES AND METER TRANSFORMER CABINETS MOUNTED INSIDE, DIRECTLY TO, OR WITHIN SIX FEET OF, THE BUILDING THEY SERVE SHALL BE BONDED TO THE BUILDING'S GROUNDING SYSTEM IN ACCORDANCE WITH LOCAL ELECTRICAL CODE (OR THE LATEST EDITION OF THE NATIONAL ELECTRICAL CODE (NEC) IF NO CODE HAS BEEN ADOPTED LOCALLY). A SEPARATE GROUND ROD IS NOT REQUIRED IN THIS CASE.

THE METER CONNECTION DEVICE OR METER TRANSFORMER CABINET SHALL BE BONDED TO THE GROUNDED SERVICE CONDUCTOR, AND GROUNDED TO A SEPARATE GROUND ROD, WHEN:

1. THE METER CONNECTION DEVICE OR METER TRANSFORMER CABINET IS MOUNTED TO A POLE, PEDESTAL, OR OTHER SIMILAR DEVICE, AND IS MORE THAN SIX FEET FROM THE BUILDING THAT IT SERVES; OR
2. THE METER CONNECTION DEVICE OR METER TRANSFORMER CABINET IS INSTALLED TO SERVE ANYTHING OTHER THAN A PERMANENT BUILDING (SUCH AS A BOAT DOCK, RV/TRAILER BERTH, LIGHTING SYSTEM, ETC.).

UNDER THESE CIRCUMSTANCES, COMMUNICATIONS SYSTEMS SHOULD NOT BE BONDED TO THE METERING EQUIPMENT. A WARNING LABEL SIMILAR TO FIGURE 1 SHALL BE AFFIXED TO THE METER CONNECTION DEVICE OR METERING TRANSFORMER CABINET AT THE TIME OF INSTALLATION. AN INTERSYSTEM BONDING TERMINATION COMPLYING WITH LATEST EDITION OF NEC ARTICLE 250.94 IS RECOMMENDED IN THESE CASES, AND MAY BE MARKED WITH THE LABEL ILLUSTRATED IN FIGURE 2.

ALL GROUND RODS SHALL HAVE THE TOP OF THE GROUND ROD FLUSH WITH THE FINAL GRADE. THE GROUND ROD AND ALL CONDUCTORS CONNECTING IT TO THE METER CONNECTION DEVICE OR METER TRANSFORMER CABINET SHALL BE ACCESSIBLE FOR INSPECTION BY THE COMPANY. GROUND RODS SHALL HAVE A MINIMUM CLEARANCE FROM ALL METER CONNECTION DEVICES OF 6 INCHES.

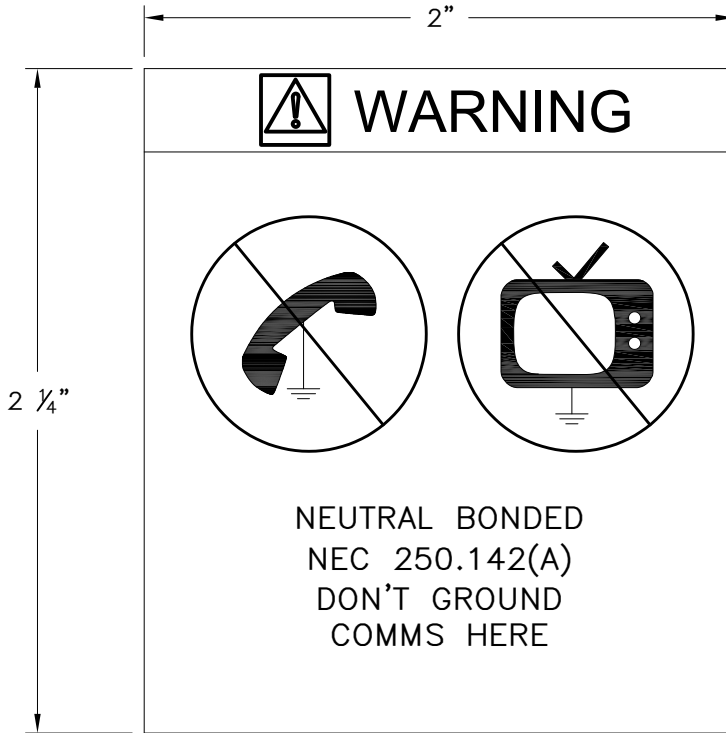

FIGURE 1

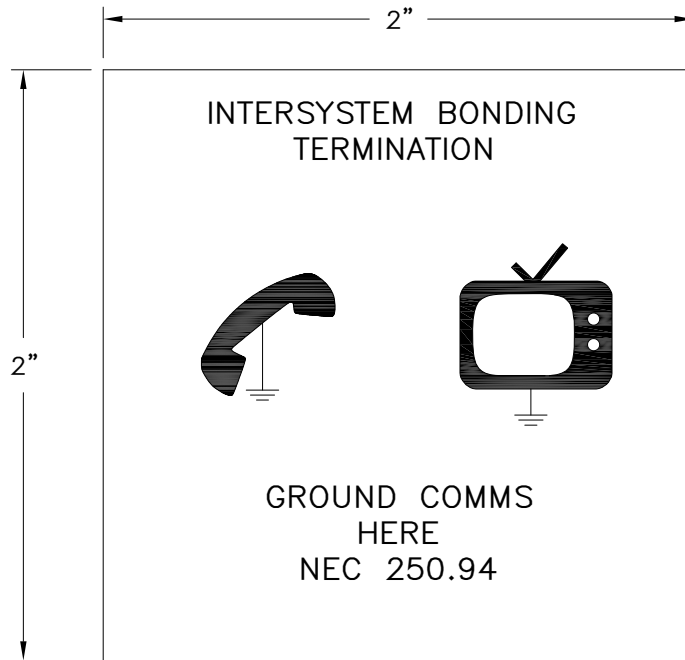
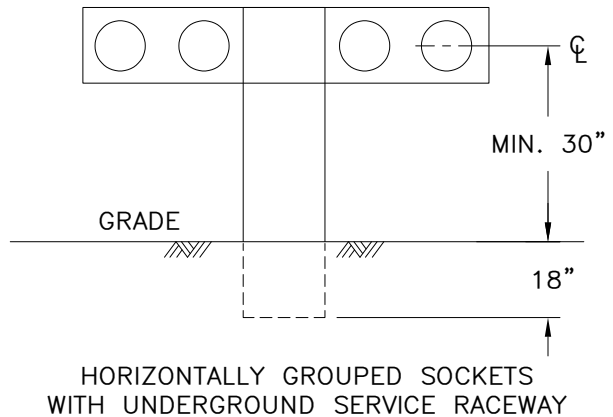
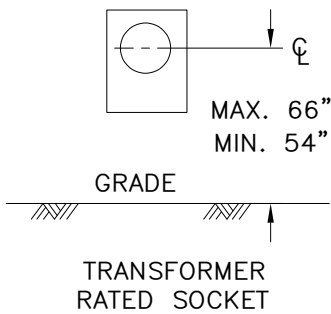
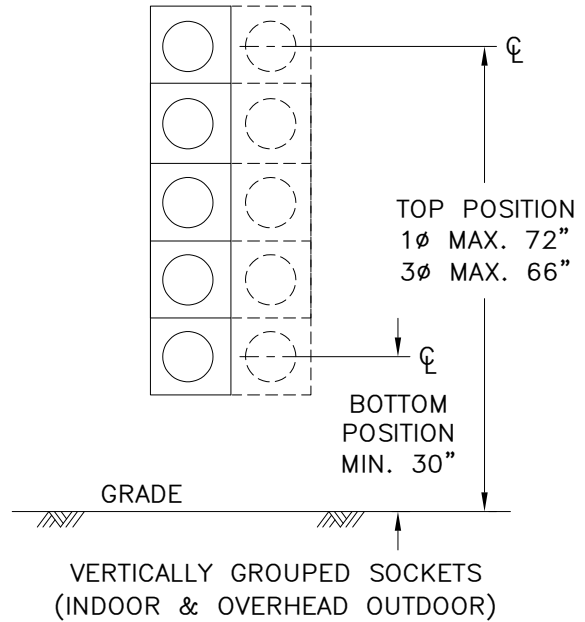
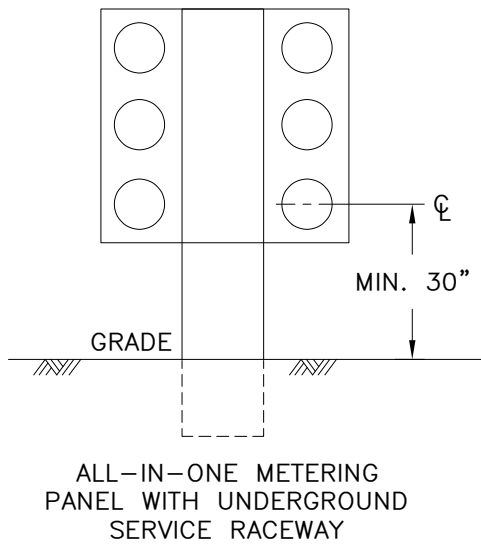
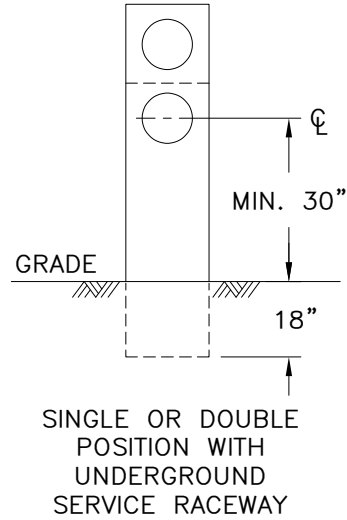
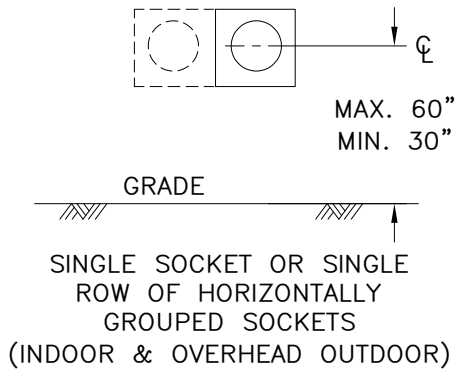
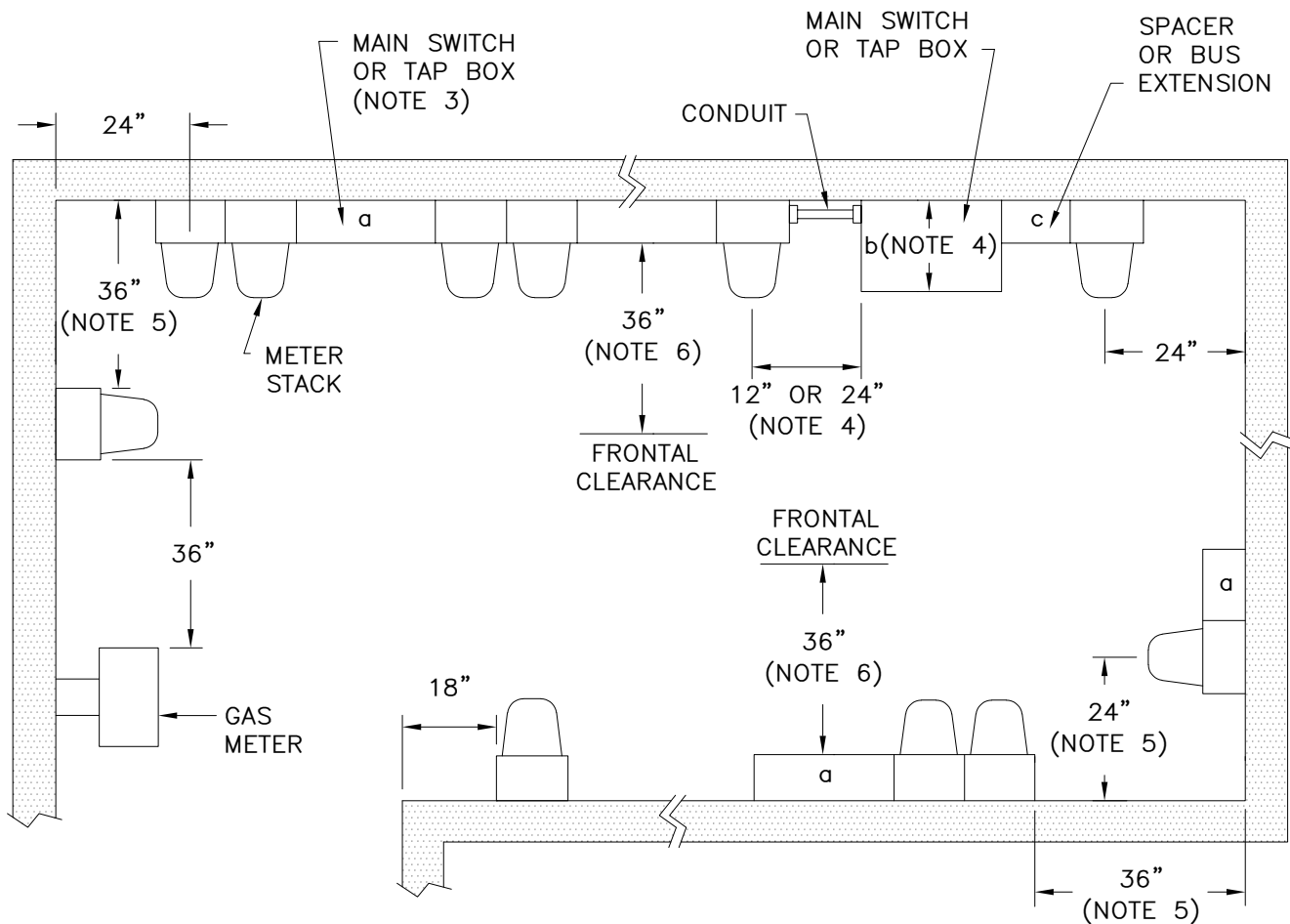

FIGURE 2

MOUNTING HEIGHT OF METER SOCKETS



FRONTAL AND SIDE CLEARANCES

NOTES (APPLICABLE TO THIS PAGE ONLY):

1. ALL DIMENSIONS SHOWN ARE MINIMUM DIMENSIONS.
2. METER CONNECTION DEVICE APPROVAL (CECHA) IS NOT A LOCATION OR SPACE APPROVAL. LOCATION OF EQUIPMENT MUST COMPLY WITH DIMENSIONS SHOWN ON THIS SKETCH AND METER MOUNTING HEIGHT DIMENSIONS SHOWN ON PAGE 4.
3. MAIN SWITCH OR TAP BOX (a) CAN BE MOUNTED UP AGAINST METER STACKS WHEN UNITS ARE OF EQUIVALENT DEPTH.
4. SEPARATION WILL BE REQUIRED BY SPACER, CONDUIT OR BUS EXTENSION (c) WHEN MAIN SWITCH OR TAP BOX (b) EXTENDS BEYOND ADJACENT METER STACK AS FOLLOWS:
 - A. IF DEPTH OF MAIN SWITCH OR TAP BOX IS 15" OR LESS, A SIDE CLEARANCE OF 12" TO CENTER LINE OF ADJACENT METER STACK IS REQUIRED.
 - B. IF DEPTH OF MAIN SWITCH OR TAP BOX IS GREATER THAN 15", A SIDE CLEARANCE OF 24" WILL BE REQUIRED.
5. THESE DIMENSIONS APPLY WHEN METER STACKS ARE MOUNTED ON ADJACENT CORNER WALLS.
6. THE WORKING SPACE SHALL BE CLEAR AND EXTEND FROM THE GRADE, FLOOR, OR PLATFORM TO A MINIMUM HEIGHT OF 80", WIDTH OF 30" AND DEPTH OF 36". METERS ARE NOT TO BE INSTALLED OVER A SIDEWALK, DRIVEWAY OR PAVED AREAS WITHOUT PROTECTIVE BARRIERS. METERS ARE NOT TO BE INSTALLED IN LOCATIONS SUSCEPTIBLE TO VEHICLE DAMAGE.

SWINGING DOOR CLEARANCES

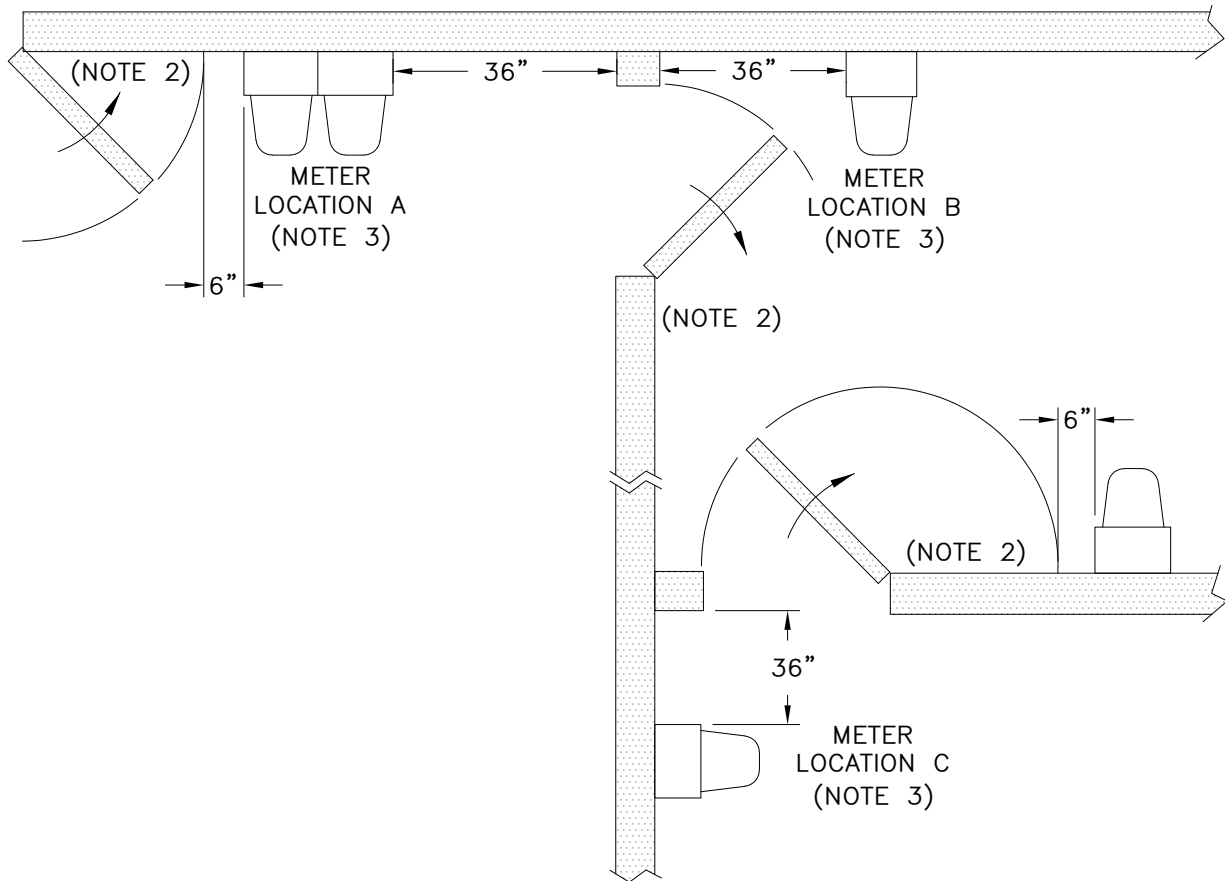
NOTES (APPLICABLE TO THIS PAGE ONLY):

1. ALL DIMENSIONS SHOWN ARE MINIMUM DIMENSIONS.
2. METERS ARE NOT TO BE INSTALLED ON WALLS WHERE THEY WILL BE BEHIND AN OPEN SWINGING DOOR.
3. METERS IN LOCATIONS A, B & C MAY REQUIRE PROTECTIVE BARRIERS IF TRAFFIC THROUGH DOORWAY COULD CAUSE METER DAMAGE. A MINIMUM CLEARANCE OF 6" IS REQUIRED FROM THE NEAREST EDGE OF THE METER CONNECTION DEVICE TO THE BARRIER.

METERING – GENERAL INFORMATION

NOTES:

APPLICATION

- THIS STANDARD PROVIDES GENERAL INFORMATION REGARDING METERING INSTALLATIONS.

METERING

GENERAL

- 1.1 IT IS NECESSARY THAT EACH RETAIL CUSTOMER LOCATED IN THE COMPANY'S SERVICE TERRITORY IS PROVIDED WITH SEPARATE METER-RELATED FACILITIES AND DESIGNATED AS A SEPARATE RETAIL CUSTOMER PER GENERAL TERMS AND CONDITIONS (GT&C).
- 1.2 METERING EQUIPMENT WHICH WILL BE PROVIDED BY THE COMPANY CONSISTS OF ONE OR MORE OF THE FOLLOWING ITEMS AS ARE REQUIRED FOR THE PARTICULAR INSTALLATION; AMI METERS, ASSOCIATED DEVICES AND INSTRUMENT TRANSFORMERS. THE EQUIPMENT SUPPLIED BY THE COMPANY FOR A SPECIFIC INSTALLATION WILL BE DEPENDENT UPON THE BILLING REQUIREMENTS OF THE APPLICABLE RATE AND THE COMPANY'S STANDARD PRACTICES. IN NO CASE WILL THE COMPANY ALLOW METERING EQUIPMENT TO BE INSTALLED ON ITS POLES OR EQUIPMENT.
- 1.3 TAMPERING WITH A COMPANY METER, BREAKING OF METER SEALS, AND/OR INSTALLING CONDUCTORS TO CARRY UNMETERED CURRENT IS PROHIBITED BY LAW. METERS OR SERVICE CONNECTIONS, ETC. SHALL NOT BE DISCONNECTED, REMOVED OR RELOCATED WITHOUT THE COMPANY'S AUTHORIZATION. TAMPERING WITH ANY METER, THE ASSOCIATED WIRING OR RELATED FACILITIES TO REDUCE A CUSTOMER'S METERED USAGE MAY RESULT IN DISCONNECTION OF SERVICE AND/OR REQUIRE A SERVICE DEPOSIT. IN ADDITION, THE CUSTOMER WILL BE BILLED FOR THE ESTIMATED REVENUE LOSS ATTRIBUTABLE TO THE SAID TAMPERING PLUS ALL RELATED EXPENSES INCURRED IN REPLACING AND/OR REPAIRING FACILITIES.
- 1.4 REFER TO C9110.

METERING SEQUENCE

2.1 DEFINITION

A METER-SWITCH-FUSE SEQUENCE IS AN INSTALLATION WHERE THE METERING EQUIPMENT IS CONNECTED TO THE SUPPLY SIDE OF THE DISCONNECTING MEANS INSTALLED IN CONJUNCTION WITH THE METER. A SWITCH-FUSE-METER SEQUENCE IS AN INSTALLATION WHERE THE METERING EQUIPMENT IS CONNECTED ON THE LOAD SIDE OF THE DISCONNECTING MEANS INSTALLED IN CONJUNCTION WITH THE METER.

- 2.2 A METER-SWITCH-FUSE SEQUENCE SHALL BE FOLLOWED FOR ALL SINGLE OR MULTI-UNIT SELF-CONTAINED OR INSTRUMENT TRANSFORMER METERING INSTALLATIONS.



- 2.3 WHERE VARIANCES OR EXCEPTIONS TO THE RULES FOR METERING SEQUENCE ARE REQUESTED, THE COMPANY'S APPROVAL MUST BE OBTAINED PRIOR TO INSTALLATION. CONTACT DISTRIBUTION STANDARDS DEPARTMENT FOR FURTHER ASSISTANCE.

TYPES OF METERINGSELF-CONTAINED INSTALLATIONS

- 3.1 SELF-CONTAINED METERING EQUIPMENT SHALL BE INSTALLED FOR ALL NEW OR REVISED INSTALLATIONS IF THE SUPPLY VOLTAGE OF THE SERVICE TO BE METERED IS 480 VOLTS OR LESS AND THE DISCONNECTING MEANS HAS A RATING EQUAL TO OR LESS THAN:
- A. 200 AMPERES, THREE-PHASE.
 - B. 350 AMPERES, SINGLE-PHASE FOR NON-RESIDENTIAL CUSTOMERS.
 - C. 400 AMPERES, SINGLE-PHASE FOR RESIDENTIAL CUSTOMERS.

THE PROVISIONS OF PARAGRAPH 3.4 SHALL APPLY TO B. ABOVE WHEN THE DISCONNECTING MEANS IS OVER 300 AMPERES AND IS "U.L. LISTED FOR CONTINUOUS DUTY OF 100% OF ITS RATING".

- 3.2 ALL NEW OR REVISED SELF-CONTAINED METER EQUIPMENT SHALL BE CECHA APPROVED, RINGLESS STYLE, AND HAVE PROVISIONS FOR BYPASS.
- 3.3 REFER TO C9120, C9121, C9122, C9125, C9126, C9127, C9130, C9132, C9134.

INSTRUMENT TRANSFORMER INSTALLATIONS

- 3.4 A CURRENT TRANSFORMER METERING INSTALLATION (A METERING INSTALLATION WHICH UTILIZES CURRENT TRANSFORMERS) SHALL BE INSTALLED FOR ALL NEW INSTALLATIONS OR INSTALLATIONS REVISED TO PROVIDE FOR ADDITIONAL LOAD IF THE SUPPLY VOLTAGE OF THE SERVICE TO BE METERED IS 480 VOLTS OR LESS AND THE DISCONNECTING MEANS HAS A RATING IN EXCESS OF:
- A. 200 AMPERES, THREE-PHASE.
 - B. 350 AMPERES, SINGLE-PHASE FOR NON-RESIDENTIAL CUSTOMERS.
 - C. 400 AMPERES, SINGLE-PHASE FOR RESIDENTIAL CUSTOMERS.
 - D. 300 AMPERES, SINGLE-PHASE FOR ALL CUSTOMERS WHEN THE DISCONNECTING MEANS IS "U.L. LISTED FOR CONTINUOUS DUTY OF 100% OF ITS RATING".
- 3.5 ANY EXISTING SELF-CONTAINED METERING INSTALLATION SHALL BE REPLACED WITH A CURRENT TRANSFORMER METERING INSTALLATION RATED AT MORE THAN 200 AMPERES WHEN THE CUSTOMER'S MEASURED MAXIMUM DEMAND INDICATES THAT THE CURRENT IN ONE OR MORE PHASES EQUALS OR EXCEEDS:
- A. 150 AMPERES IF THE METER IS BOTTOM CONNECTED AND THE DISCONNECTING MEANS IS RATED IN EXCESS OF 200 AMPERES.
 - B. 200 AMPERES REGARDLESS OF THE TYPE OF METERING NOW INSTALLED AND THE SERVICE ENTRANCE EQUIPMENT IS RATED AT 200 AMPERES OR MORE.
- 3.6 WHERE THE SUPPLY VOLTAGE IS HIGHER THAN 480 VOLTS, CURRENT AND POTENTIAL TRANSFORMERS SHALL BE INSTALLED FOR ALL NEW OR REVISED METERING INSTALLATIONS.
- 3.7 METERED AND UNMETERED CONDUCTORS SHALL NOT BE INSTALLED IN THE SAME CONDUIT, RACEWAY OR SWITCHBOARD SECTION UNLESS SEPARATED BY AN APPROVED BARRIER OR RACEWAY. CONTACT DISTRIBUTION STANDARDS FOR CASE-BY-CASE APPROVAL.
- 3.8 THESE INSTALLATIONS REQUIRE A TRANSFORMER RATED METER CABINET ALONG WITH A CECHA APPROVED METER FITTING THAT INCLUDES TEST SWITCHES.
- 3.9 REFER TO C9140, C9145 OR C9150.

LOCATION OF METERING EQUIPMENT
ALL TYPES

GENERAL

- 4.1 THE CUSTOMER SHALL PROVIDE A SUITABLE PLACE FOR THE METERING EQUIPMENT WHICH SHALL BE READILY ACCESSIBLE TO EMPLOYEES OF THE COMPANY FOR THE READING, TESTING, INSPECTING OR EXCHANGING OF SUCH EQUIPMENT. THE LOCATION OF THE EQUIPMENT SHALL NOT CONFLICT WITH STATE OR LOCAL GOVERNMENTAL CODE REQUIREMENTS. THE CUSTOMER SHALL CONSULT THE COMPANY REGARDING THE PROPER LOCATION OF THE EQUIPMENT.
- 4.2 FOR ALL NEW AND REVISED SINGLE-PHASE AND THREE-PHASE INSTALLATIONS REQUIRING THE USE OF A SELF-CONTAINED METER, THE METERING EQUIPMENT SHALL BE INSTALLED OUTSIDE OF THE BUILDING.
- 4.3 FOR ALL NEW AND REVISED SINGLE-PHASE AND THREE-PHASE INSTALLATIONS REQUIRING THE USE OF INSTRUMENT TRANSFORMERS, THE METERING EQUIPMENT SHALL BE LOCATED AS SPECIFIED BELOW:
- A. WHEN THE UTILIZATION VOLTAGE IS 480 VOLTS OR LESS AND THE DISCONNECTING MEANS IS RATED AT 200 THROUGH 1200 AMPERES, THE METERING EQUIPMENT, WHERE PRACTICABLE, SHALL BE INSTALLED OUTSIDE OF THE BUILDING. THE METERING EQUIPMENT INCLUDES THE METERS, THE ASSOCIATED CURRENT TRANSFORMERS AND THE DEMAND METERING EQUIPMENT.
- B. FOR ALL OTHER INSTALLATIONS REQUIRING THE USE OF INSTRUMENT TRANSFORMERS, THE METERING EQUIPMENT MAY BE LOCATED WITHIN THE BUILDING UNLESS AN OUTDOOR INSTALLATION OF ANY OR ALL OF THE COMPONENTS IS SPECIFICALLY DESIGNATED BY THE COMPANY.
- 4.4 METERING EQUIPMENT SHALL NOT, FOR EXAMPLE, BE INSTALLED IN ANY OF THE FOLLOWING LOCATIONS:
- | | |
|-------------------|--------------------------------------|
| ATTICS | KITCHENS |
| BATHROOMS | LAVATORIES |
| BEDROOMS | LIVING ROOMS |
| CHEMICAL ROOMS | MANHOLES |
| CLOTHES CLOSETS | SHAFTS |
| COAL BINS | SHOWERS AND LOCKER ROOMS |
| CRAWL SPACES | STAIRWAYS |
| DOG YARDS OR RUNS | STOREROOMS |
| INCINERATOR ROOMS | BASEMENTS PROJECTING UNDER SIDEWALKS |
- 4.5 METERING EQUIPMENT SHALL NOT, FOR EXAMPLE, BE INSTALLED BEHIND, OVER, UNDER, OR ADJACENT TO THE FOLLOWING:
- | | |
|-------------------|------------------------------|
| BOILERS | NATURAL GAS METER (SEE NOTE) |
| CHEMICAL TANKS | RADIATORS |
| DOORS | SINKS |
| EXPOSED MACHINERY | STEAM PIPES |
| FIRE ESCAPES | STOVES |
| FURNACES | TANKS |
| HATCHES | TRACKS FOR OVERHEAD DOORS |
| HEATERS | WINDOWS |
| LAUNDRY TUBS | |

NOTE: METERING EQUIPMENT MUST MAINTAIN A 3 FOOT MINIMUM CLEARANCE FROM A NATURAL GAS METER – SEE C9110.

- 4.6 METERING EQUIPMENT SHALL NOT BE INSTALLED IN LOCATIONS WHERE THERE IS EXCESSIVE HEAT, MOISTURE, VIBRATIONS, FUMES, A CORROSIVE OR EXPLOSIVE ATMOSPHERE OR DUST, OR AGAINST DOWNSPOUTS, OR IN LOCATIONS SUBJECT TO FLOODING.
- 4.7 OUTDOORS, METERING EQUIPMENT SHALL NOT PROTRUDE OVER A SIDEWALK, DRIVEWAY, LOADING RAMP, OR BE EXPOSED TO POSSIBLE MECHANICAL DAMAGE.
- 4.8 METERING EQUIPMENT SHALL NOT BE INSTALLED WITHIN 3 FEET OF ANY GAS METER, GAS VALVE, OR DISCONNECTED GAS FITTING. METERING EQUIPMENT SHALL NOT BE INSTALLED IN AREAS WITH A CORROSIVE OR EXPLOSIVE ATMOSPHERE.
- 4.9 ACCESS TO METER LOCATIONS (METER ROOMS) SHALL BE THROUGH PUBLIC WALKWAYS, HALLS, ETC. AND NOT THROUGH LOCKED OR PRIVATE ROOMS, TENANT SPACE, LAVATORIES, LIMITED ACCESS WAYS, ETC.
- 4.10 METERING EQUIPMENT APPROVED FOR INSTALLATION INDOORS SHALL BE LOCATED AS NEAR AS PRACTICABLE TO THE POINT WHERE THE SERVICE ENTRANCE CONDUCTORS ENTER THE BUILDING AND IN ACCORDANCE WITH LOCAL CODE REQUIREMENTS. WHEN TWO OR MORE METERING EQUIPMENT DEVICES ARE INSTALLED WITHIN THE BUILDING, THE METER DEVICES SHALL BE GROUPED TOGETHER IN THE SAME ROOM AND ON THE SAME WALL.
- 4.11 WHERE METERING EQUIPMENT IS INSTALLED ON BALCONIES, ACCESS MUST BE BY STAIRS, NOT SHIP LADDERS. THE CUSTOMER MUST PROVIDE PLATFORM SPACE IN FRONT OF THE METERING EQUIPMENT OF AT LEAST 3 FEET AND BE PROTECTED BY A SUITABLE RAILING.
- 4.12 WHERE METERING EQUIPMENT IS TO BE INSTALLED IN A NARROW PASSAGEWAY OR IN A NARROW SPACE SUCH AS IN BACK OF TANKS, SWITCHBOARDS, OR MACHINES PROPERLY GUARDED, THE MINIMUM CLEAR SPACE IN FRONT OF THE METERING EQUIPMENT SHALL BE THREE FEET.
- 4.13 METERING EQUIPMENT PLACED BEHIND UNINSULATED HEATING TANKS, MACHINES IN MOTION, ETC., SHALL BE LOCATED AT A DISTANCE FROM SUCH EQUIPMENT AS SPECIFIED BY THE COMPANY.
- 4.14 FOR LARGE MULTIPLE-OCCUPANCY BUILDINGS REQUIRING AN INDOOR LOCATION FOR THE METERING EQUIPMENT, THE EQUIPMENT MAY BE GROUPED TOGETHER AND INSTALLED IN AN ACCESSIBLE LOCATION IN THE BASEMENT OR ON THE FIRST FLOOR. HIGH-RISE BUILDINGS MAY FIND IT MORE PRACTICABLE TO HAVE THE METERING EQUIPMENT LOCATED ON EACH OR EVERY OTHER FLOOR IN SPECIAL METER ROOMS. METERS SHALL NOT BE INSTALLED IN INDIVIDUAL TENANT SPACE. WHERE METER ROOMS ARE NECESSARY, THEY SHALL BE OF SUFFICIENT SIZE TO ALLOW READY ACCESS TO THE METER AND ITS ACCESSORIES FOR THE PURPOSE OF READING, TESTING, AND MAINTENANCE. WHERE METER ROOMS ARE LOCKED, KEYS MUST BE AVAILABLE TO COMPANY PERSONNEL AT ALL TIMES.

FOR HIGH-RISE METERING REQUIREMENTS, REFER TO **C9114**.

METERING VOLTAGE OVER 600 VOLTS

- 4.15 THE RULES HEREIN STATED WILL ALSO APPLY TO THE LOCATION OF AMI METERS WHERE THE METERING VOLTAGE EXCEEDS 600 VOLTS. THE LOCATION OF THE INSTRUMENT TRANSFORMERS WILL VARY WITH THE VOLTAGE AND TYPE OF SERVICE. SPECIFICATIONS AND PRINTS SHALL BE SUBMITTED TO DISTRIBUTION STANDARDS FOR APPROVAL AS RELATED TO DISTRIBUTION STANDARDS REQUIREMENTS BEFORE ANY EQUIPMENT IS PURCHASED, INSTALLED OR CONSTRUCTED.
- 4.16 WHERE VARIANCES OR EXCEPTIONS TO THE RULES FOR METERING LOCATION ARE REQUESTED, DISTRIBUTION STANDARDS APPROVAL MUST BE OBTAINED PRIOR TO INSTALLATION.

INSTALLATION REQUIREMENTSGENERAL

- 5.1 CECHA APPROVED METER CONNECTION DEVICES (BOTH INDOOR AND OUTDOOR) SHALL BE FURNISHED, INSTALLED AND MAINTAINED BY THE CUSTOMER.
- 5.2 THE COMPANY HAS CERTAIN MINIMUM AND MAXIMUM MOUNTING HEIGHTS AS WELL AS MINIMUM ACCEPTABLE FRONT AND SIDE CLEARANCES FOR METER INSTALLATIONS. THIS INFORMATION IS AVAILABLE – REFER TO **C9110**.
- 5.3 WHEN METERING EQUIPMENT IS INSTALLED IN A MULTIPLE-OCCUPANCY BUILDING (TWO OR MORE OCCUPANTS), EACH METER CONNECTION DEVICE SHALL BE LABELED, TAGGED, OR STENCILED SHOWING THE COMPLETE ADDRESS AND LOCATION OF THE AREA SERVED. THIS INCLUDES THE APARTMENT, OFFICE, OR STORE IN THE BUILDING FOR WHICH THE METERING EQUIPMENT IS BEING INSTALLED.
- 5.4 CONDUIT OR WIRE CONNECTIONS TO AN INSTRUMENT TRANSFORMER METER CONNECTION DEVICE SHALL BE MADE BELOW THE METER TEST SWITCH USING THE KNOCKOUTS PROVIDED.
- 5.5 ALL METERING FACILITIES SHALL BE INSTALLED IN SUCH A MANNER AS TO BE PLUMB AND TO INSURE PERMANENT ATTACHMENT TO A RIGID, VIBRATION-FREE WALL OR STRUCTURE.

SELF-CONTAINED METER CONNECTION DEVICES

- 5.6 THE CUSTOMER SHALL PROVIDE AND INSTALL A MOUNTING BOARD IN ACCORDANCE WITH THE COMPANY'S SPECIFICATIONS FOR ALL INDOOR INSTALLATIONS OF SINGLE OR MULTIPLE-POSITION METER CONNECTION DEVICES WHERE THE CONDITION OF THE WALL PRECLUDES A PLUMB INSTALLATION.
- 5.7 IN THE CASE OF MULTIPLE-POSITION OR GROUPED METER CONNECTION DEVICES, CONDUCTORS OR BUS FROM THE SOURCE OF SUPPLY SHALL BE CONTINUOUS TO THE LAST METER CONNECTION DEVICE AND CONNECTED TO THE METER CONNECTION DEVICE TERMINALS IN ACCORDANCE WITH THE COMPANY'S REQUIREMENTS.
- 5.8 METERED LOAD CONDUCTORS SHALL NOT PASS THROUGH ADJACENT METER CONNECTION DEVICES UNLESS SUCH CONDUCTORS ARE PROPERLY BARRIERED FROM THE UNMETERED CONDUCTORS AND ARE AN INTEGRAL PART OF AN APPROVED PREWIRED MULTIPLE-POSITION METER SOCKET ASSEMBLY.
- 5.9 WHERE METER CONNECTION DEVICES ARE INSTALLED IN LOCATIONS NOT ADJACENT TO THE SERVICE ENTRANCE, THE UNMETERED FEEDER CONDUCTORS, TO THE EXTENT PRACTICABLE, SHOULD BE INSTALLED WITH A CONTINUOUS RUN OF CONDUIT AND CABLE WITHOUT SPLICE BOXES OR SIMILAR TYPE FITTINGS.

INSTRUMENT TRANSFORMERS

- 5.10 AN INSTRUMENT TRANSFORMER METERING INSTALLATION GENERALLY CONSISTS OF INSTRUMENT TRANSFORMERS, AN INSTRUMENT TRANSFORMER CABINET CONTAINING COLOR-CODED CONDUCTORS, A METER CONNECTION DEVICE WITH TEST SWITCHES AND A WATT-HOUR METER WITH AN APPROPRIATE DEMAND DEVICE.
- 5.11 EXCEPT WHERE INSTRUMENT TRANSFORMERS ARE A PART OF AN ELECTRIC SERVICE STATION, THEY SHALL BE INSTALLED BY THE CUSTOMER.
- 5.12 UNLESS OUTDOOR TYPE INSTRUMENT TRANSFORMERS ARE PROVIDED, THE CUSTOMER SHALL FURNISH, INSTALL AND MAINTAIN A CABINET APPROVED BY THE COMPANY OR UNDER THE CONDITIONS SET FORTH IN PARAGRAPHS 6.13 AND 6.14, A SUITABLE ENCLOSURE FOR THE INSTRUMENT TRANSFORMERS. IF THE CABINET IS TO BE INSTALLED OUTDOORS, IT SHALL BE WEATHERPROOF.

- 5.13 UPON SPECIFIC APPROVAL BY THE COMPANY, INSTRUMENT TRANSFORMERS MAY BE INSTALLED IN A COMMON CABINET WITH THE DISCONNECTING MEANS PROVIDED THAT THE PORTION OF THE CABINET CONTAINING THE TRANSFORMERS IS SEPARATED BY MEANS OF AN ISOLATING BARRIER FROM THE PORTION CONTAINING THE DISCONNECTING MEANS AND, PROVIDED FURTHER, THAT THE CABINET IS CONSTRUCTED IN ACCORDANCE WITH THE COMPANY'S REQUIREMENTS. IN THE CASE OF SUCH AN INSTALLATION THE CONNECTION OF THE SUPPLY CONDUCTORS TO EITHER THE DISCONNECTING MEANS OR THE CURRENT TRANSFORMER SHALL BE ACCESSIBLE FOR INSPECTION. THE INSTRUMENT TRANSFORMER COMPARTMENT SHALL CONTAIN ONLY SUPPLY CONDUCTORS AND METER WIRING. SPECIFICATIONS AND PRINTS SHALL BE SUBMITTED TO THE COMPANY FOR APPROVAL AS RELATED TO COMPANY REQUIREMENTS BEFORE ANY EQUIPMENT IS PURCHASED OR CONSTRUCTED.
- 5.14 WHERE THE EQUIPMENT AND WIRING REQUIREMENTS FOR AN INSTRUMENT TRANSFORMER INSTALLATION ARE NOT SET FORTH IN THE COMPANY'S CURRENT PUBLISHED DRAWINGS AND SPECIFICATIONS, THE CUSTOMER SHALL FURNISH SPECIFICATIONS AND PRINTS FOR COMPANY APPROVAL AS RELATED TO COMPANY REQUIREMENTS OF SUCH INSTALLATION BEFORE ANY EQUIPMENT IS PURCHASED OR CONSTRUCTED. THIS EQUIPMENT SHALL BE INSTALLED IN ACCORDANCE WITH COMPANY REQUIREMENTS.

COLOR-CODED WIRES

- 5.15 EXCEPT WHERE THE METER IS MOUNTED ON THE DOOR OF THE INSTRUMENT CABINET, WITH APPROPRIATE WIRING CONNECTIONS, THE CUSTOMER SHALL PROVIDE A SUITABLE CONDUIT EXTENDING BETWEEN THE INSTRUMENT TRANSFORMER CABINET AND THE METER CONNECTION DEVICE. THE CUSTOMER SHALL INSTALL SUCH CONDUIT, EXPOSED WHERE PRACTICABLE, AND THE COLOR-CODED CONDUCTORS (PROVIDED BY THE COMPANY) WHICH CONNECT THE INSTRUMENT TRANSFORMERS TO THE METER TEST SWITCH. THE COMPANY WILL MAKE THE FINAL CONNECTIONS. WHERE THE INSTRUMENT TRANSFORMERS ARE TO BE INSTALLED ON A COMPANY POLE OR STRUCTURE, THE COMPANY WILL PROVIDE THE CONDUIT TO BE INSTALLED ON THE POLE OR STRUCTURE AND INSTALL THE INSTRUMENT TRANSFORMERS, THE CONDUIT AND CONDUCTORS ON THE POLE OR STRUCTURE.

COMPLIANCE

- 5.16 THE COMPANY MAY REFUSE TO CONNECT SERVICE IF, IN ITS JUDGMENT, THE CUSTOMER'S METERING INSTALLATION DOES NOT MEET THE COMPANY'S REQUIREMENTS HEREIN STATED. AFTER SERVICE IS CONNECTED, THE CUSTOMER IS RESPONSIBLE FOR THE ADEQUACY, CONFORMANCE TO CODES, SAFETY AND RELIABILITY OF THE EQUIPMENT AND FACILITIES OWNED, INSTALLED AND MAINTAINED BY THE CUSTOMER.

► HIGH-RISE COMM REQUIREMENTS

FOR DA & AMI PLACED WITHIN METER ROOMS & VAULTS

OF A CUSTOMER BUILDING

NOTES:

► APPLICATION

- THIS STANDARD PROVIDES INSTALLATION AND CONSTRUCTION REQUIREMENTS FOR CUSTOMERS DESIGNING INDOOR ELECTRIC METER ROOMS AND VAULTS WITHIN A HIGH-RISE BUILDING. THESE REQUIREMENTS WILL ADDRESS VAULTS AND METER ROOMS SUCH AS THOSE THAT MAY EXIST IN HIGH-RISE BUILDINGS TO ENSURE ComEd's ADVANCED METERING INFRASTRUCTURE (AMI) METERS AND DISTRIBUTION AUTOMATION (DA) EQUIPMENT ARE ESTABLISHED ON THE MESH RADIO NETWORK.
- THESE PROVISIONS ARE REQUIRED FOR COMMERCIAL AND/OR RESIDENTIAL, SINGLE OR MULTIPLE, INDOOR METER ROOMS OR VAULTS TO ENSURE SILVER SPRINGS NETWORK (SSN) COMMUNICATION ACCESS AND PERFORMANCE.
- METERS MUST COMMUNICATE WITH EACH OTHER AND, ULTIMATELY, TO ACCESS POINTS USING A MESH RADIO FREQUENCY NETWORK. DA EQUIPMENT VIA EBRIDGES MUST COMMUNICATE WITH OTHER 900MHZ NETWORK EQUIPMENT. ACCESS POINTS ACT AS THE COMMUNICATIONS LINK TO TRANSFER METER DATA BACK TO ComEd.

INFORMATION

SPECIAL PROVISIONS PROVIDED BY CUSTOMER TO FACILITATE THE INSTALLATION OF (AMI) TECHNOLOGY:

1. ACCESS BY ComEd PERSONNEL FOR REPLACEMENT OF RADIO FREQUENCY (RF) EQUIPMENT.
2. PATHWAYS FOR RF SIGNAL PROPAGATION (I.E., CONDUIT).
3. FIRESTOP SYSTEM: INSTALL AS REQUIRED BY LOCAL BUILDING, FIRE, OR ELECTRICAL CODE.
4. CONDUIT TYPE: CONDUITS INSTALLED IN WALLS, CEILINGS OR FLOORS TO BE PER APPLICABLE BUILDING CODE.
5. CONDUIT CAP: A TEMPORARY CAP, OF THE SAME TYPE AND SIZE AS THE CONDUIT, SHALL BE PLACED ON THE END OF THE CONDUIT NEXT TO THE METER PANEL.
- 6. TERMINATION ENCLOSURE: A MINIMUM 12"x12"x6" WEATHER TIGHT, FIBERGLASS ENCLOSURE, WITH AN ACCESSIBLE FRONT COVER. IT MUST BE PERMANENTLY INSTALLED TO THE BUILDING OUTSIDE WALL WITH THE CONDUIT TERMINATED INSIDE. THE ENCLOSURE SHALL BE SURFACE MOUNTED OR RECESSED AND SHALL NOT BE OBSTRUCTED BY ADJACENT STRUCTURES. THE ENCLOSURE SHALL BE NO GREATER THAN 25 FEET AND NO LESS THAN 8 FEET ABOVE THE GROUND. IF ROOF LOCATION IS DESIRED AND BUILDING IS 10 FLOORS OR MORE, CONTACT ComEd FOR EVALUATION.
7. CONDUIT BENDS: ANY BEND MUST HAVE A MINIMUM 12-INCH RADIUS.
8. CUSTOMER TO FURNISH, INSTALL AND MAINTAIN THE FOLLOWING, (REFER TO EXHIBIT A):
 - A. A CLEAR WALL SPACE OF 3 FEET WIDE BY 3 FEET HIGH IS REQUIRED IN EACH METER ROOM TO INSTALL, OPERATE, AND MAINTAIN RF TRANSCEIVER EQUIPMENT. THIS WALL SPACE IS TO MAINTAIN AN 18" CLEARANCE FROM ADJACENT METER FITTINGS OR OTHER METALLIC EQUIPMENT. IF METER ROOMS ARE LOCATED DIRECTLY OVER EACH OTHER, WALL SPACE IS ONLY REQUIRED EVERY FIFTH FLOOR.
 - B. CONNECTING EACH OF THE METER ROOM AND VAULT TO A COMMON METER ROOM. THE CONDUITS SHALL BE CAPPED IN EACH METER ROOM WITH A CAP OF THE SAME SIZE AND TYPE AS THE CONDUIT. ALL CONDUITS SHALL BE IN VERTICAL ALIGNMENT FROM FLOOR TO FLOOR.
 - C. FROM THE COMMON METER ROOM, ONE 2-INCH CONDUIT SHALL BE PROVIDED TO THE TERMINATION ENCLOSURE, (NOTE 6) ON THE EXTERIOR OF THE BUILDING. USE 12-INCH RADIUS BENDS WITH A MAXIMUM TOTAL OF 270 DEGREES OF BENDS (COUNTING ALL BENDS IN ANY ONE RUN). LEAVE # 8 GALVANIZED PULLING WIRE, NYLON CORD OR POLYPROPYLENE ROPE IN DUCT. SEAL DUCT TEMPORARILY. THE CONDUIT SHALL BE LESS THAN 100 FEET IN LENGTH. THE ONLY OPENINGS ALLOWED IN CONDUIT ARE IN ELECTRICAL METER ROOM. (NO PULLING POINTS IN CONDUIT). IF ROOF LOCATION IS DESIRED AND BUILDING IS 10 FLOORS OR MORE, CONTACT ComEd FOR EVALUATION.
 - D. CEILING LIGHTING FIXTURE LOCATED A MAXIMUM OF 10 FEET ABOVE FLOOR. THE MINIMUM REQUIRED LIGHTING INTENSITY FOR METER ROOMS IS 10 FOOTCANDLES (110 LUX MEASURED AT FLOOR LEVEL).
 - E. FROM THE VAULT, TWO ¾" CONDUITS SHALL BE PROVIDED TO THE TERMINATION ENCLOSURE, (NOTE 6) ON THE EXTERIOR OF THE BUILDING. USE 12-INCH RADIUS BENDS WITH A MAXIMUM OF 270° OF BENDS (COUNTING ALL BENDS IN ANY ONE RUN). LEAVE #8 GALVANIZED PULLING WIRE, NYLON CORD OR POLYPROPYLENE ROPE IN DUCT. SEAL DUCT TEMPORARILY. THE CONDUIT SHALL BE LESS THAN 300 FEET IN LENGTH. THE ONLY OPENINGS ALLOWED IN CONDUIT ARE IN ELECTRICAL METER ROOM. (NO PULLING POINTS IN CONDUIT).

ComEd TO FURNISH, INSTALL AND MAINTAIN THE FOLLOWING:

- 1. PLACEMENT OF ANCILLARY RF EQUIPMENT (IN-ROOM RELAY OR ACCESS POINT, AND/OR BRIDGES).
2. CABLE ROUTING.
3. PLACEMENT AND MOUNTING OF ANTENNAS.

EXHIBIT A

TYPICAL HIGH-RISE BUILDING WITH INDOOR ELECTRIC METER ROOM(S) AND VAULT(S)

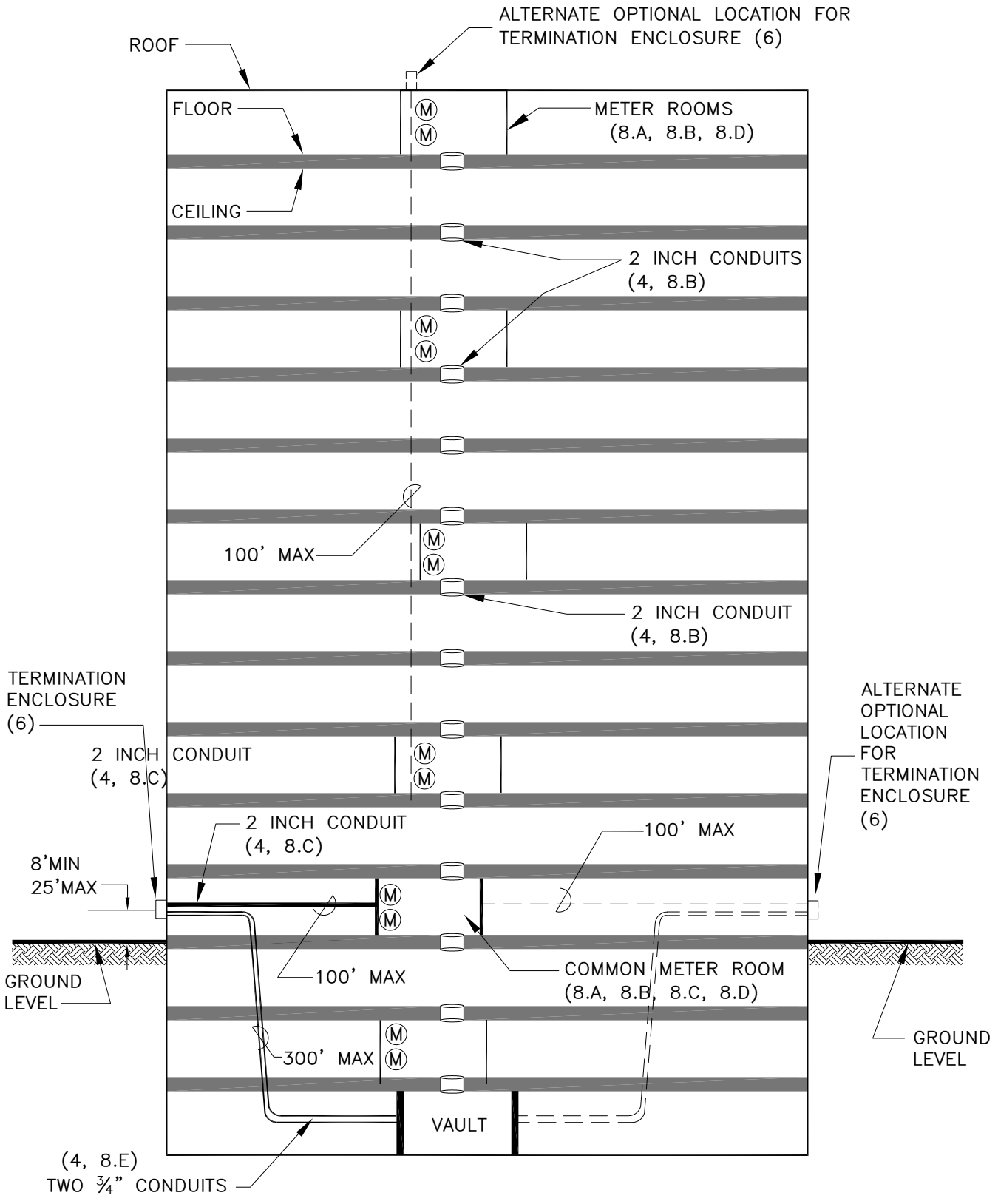

ACAD

200A 1-PHASE OVERHEAD SERVICE METER

OUTDOOR

120, 120/240 OR 120/208V

NOTES:APPLICATION:

- THIS STANDARD DESCRIBES THE REQUIREMENTS FOR THE INSTALLATION OF AN OUTDOOR SELF-CONTAINED, SINGLE OR MULTIPLE POSITION METER CONNECTION DEVICE, 1-PHASE 3-WIRE 120/240V OR 120/208V AND 1-PHASE, 2-WIRE 120V.

INFORMATION:

1. FOR THE INSTALLATION OF A:

- SINGLE POSITION 1-PHASE, 2-WIRE, 120V SERVICE METER (SEE FIGURE 1)
- SINGLE POSITION 1-PHASE, 3-WIRE 120/240V SERVICE METER (SEE FIGURE 2)
- SINGLE POSITION 1-PHASE, 3-WIRE 120/208V SERVICE METER (SEE FIGURES 3A AND 3B)
- MULTIPLE POSITION 1-PHASE, 3-WIRE 120/240V SERVICE METER (SEE FIGURE 4)
- MULTIPLE POSITION 1-PHASE, 3-WIRE 120/208V SERVICE METER (SEE FIGURES 5A AND 5B)

CUSTOMER TO FURNISH, INSTALL AND MAINTAIN THE FOLLOWING EQUIPMENT:

- A - METER CONNECTION DEVICE (200 AMPERES MAX). IF NEW METER CONNECTION DEVICE IS REQUIRED, IT MUST BE FROM ComEd APPROVED METER FITTING CATALOG.
- B - CONDUIT AND CONDUCTORS (OR SERVICE ENTRANCE CABLE WHERE PERMITTED BY LOCAL CODE) ON LINE SIDE OF METER - SERVICE RUN.
- C - CONDUIT AND CONDUCTORS (OR SERVICE ENTRANCE CABLE WHERE PERMITTED BY LOCAL CODE) ON LOAD SIDE OF METER - SERVICE ENTRANCE.
- D - GROUND CONNECTION PER LOCAL CODE, IF REQUIRED.
- E - INSULATED METALLIC BUSHING ON LINE AND LOAD CONDUITS.
- F - NEUTRAL TERMINAL.
- G - FIFTH TERMINAL WITH POTENTIAL TAP (#12 COPPER WIRE OR EQUIVALENT) FROM NEUTRAL TERMINAL (120/208 VOLT SERVICE ONLY).
- H - POTENTIAL TAP (#12 WIRE OR EQUIVALENT) TO RIGHT HAND LINE TERMINAL FROM NEUTRAL TERMINAL (2-WIRE, 120 VOLT SERVICE ONLY).

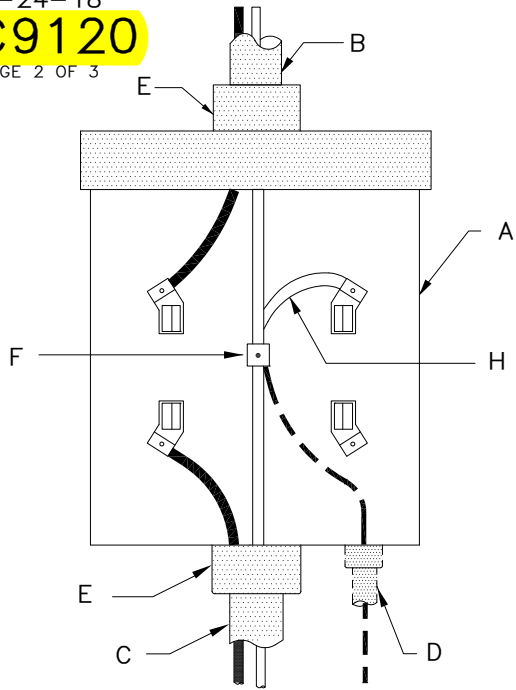

FIGURE 1

SINGLE POSITION
1-PHASE, 2-WIRE
120V, 200A MAX.

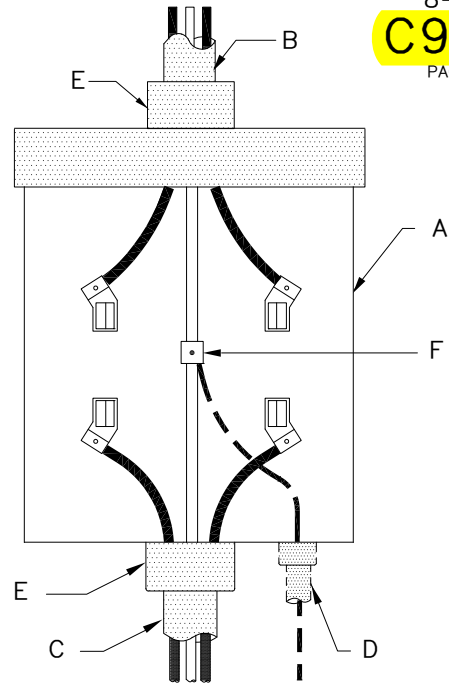

FIGURE 2

SINGLE POSITION
1-PHASE, 3-WIRE
120/240V, 200A MAX.

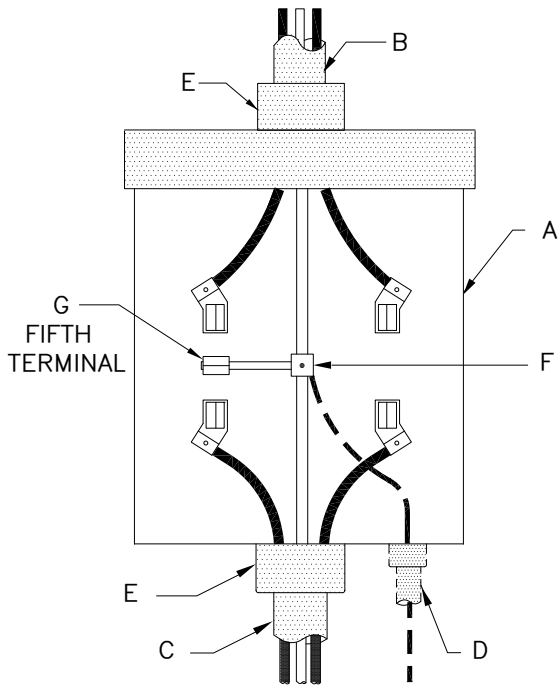

FIGURE 3A

SINGLE POSITION
1-PHASE, 3-WIRE
120/208V, 200A MAX.
FIFTH TERMINAL AT 9 O'CLOCK POSITION

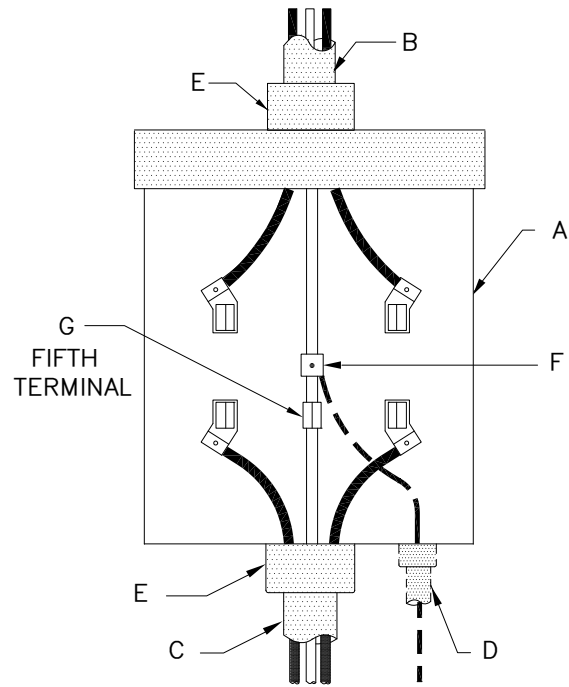

FIGURE 3B

SINGLE POSITION
1-PHASE, 3-WIRE
120/208V, 200A MAX.
FIFTH TERMINAL AT 6 O'CLOCK POSITION

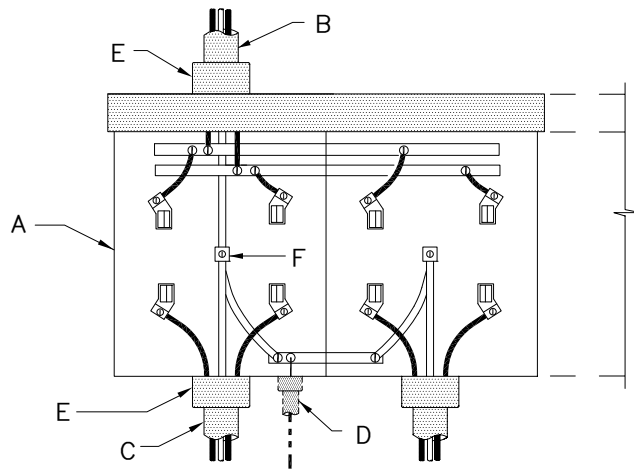

FIGURE 4

MULTIPLE POSITION (2 THROUGH 6 POSITION)
1-PHASE, 3-WIRE, 120/240V, 200A MAX.

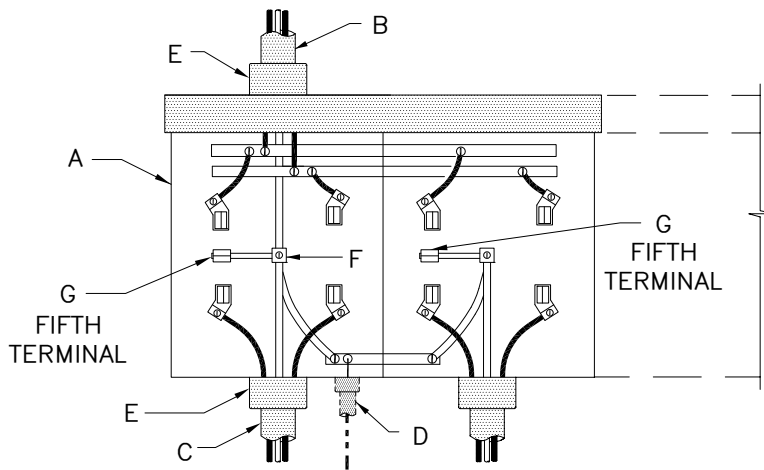

FIGURE 5A

MULTIPLE POSITION (2 THROUGH 6 POSITION)
1-PHASE, 3-WIRE, 120/208V, 200A MAX.
FIFTH TERMINAL AT 9 O'CLOCK POSITION

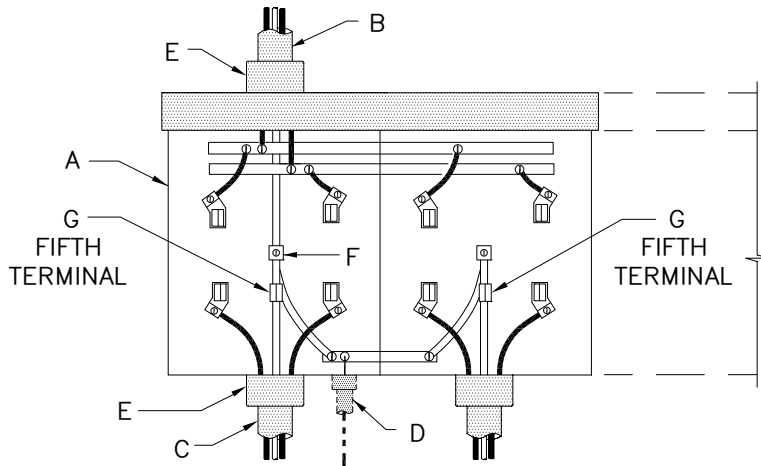

FIGURE 5B

MULTIPLE POSITION (2 THROUGH 6 POSITION)
1-PHASE, 3-WIRE, 120/208V, 200A MAX.
FIFTH TERMINAL AT 6 O'CLOCK POSITION

This page intentionally left blank

320A 1-PHASE OVERHEAD SERVICE METER

120/240 VOLT

NOTES:APPLICATION:

- THIS STANDARD DESCRIBES THE REQUIREMENTS FOR THE INSTALLATION OF AN OUTDOOR SELF CONTAINED, SINGLE POSITION METER CONNECTION DEVICE, 1-PHASE, 3-WIRE 120/240V.

INFORMATION:

- CUSTOMER TO FURNISH, INSTALL AND MAINTAIN THE FOLLOWING EQUIPMENT (SEE FIGURE 1):

- A - METER CONNECTION DEVICE WITH LEVER ACTUATED BY-PASS (320 AMPERES MAXIMUM). IF NEW METER CONNECTION DEVICE IS REQUIRED, IT MUST BE FROM THE ComEd APPROVED METER FITTING CATALOG.
- B - CONDUIT AND CONDUCTORS (OR SERVICE ENTRANCE CABLE WHERE PERMITTED BY LOCAL CODE) ON LINE SIDE OF METER - SERVICE RUN.
- C - CONDUIT AND CONDUCTORS (OR SERVICE ENTRANCE CABLE WHERE PERMITTED BY LOCAL CODE) ON LOAD SIDE OF METER - SERVICE ENTRANCE.

- D - GROUND CONNECTION PER LOCAL CODE, IF REQUIRED.
- E - INSULATED METALLIC BUSHING ON LINE AND LOAD CONDUITS.
- F - COMPRESSION LUGS FOR LINE AND LOAD CONDUCTORS.
- G - NEUTRAL TERMINAL.
- H - BY-PASS LEVER.

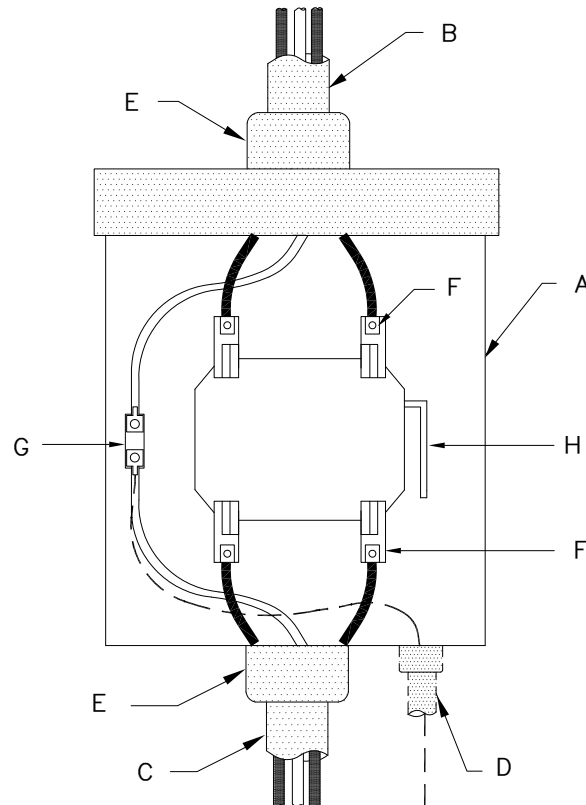

FIGURE 1

1-PHASE, 3-WIRE
120/240V - 320A MAX.

This page intentionally left blank

200A 1-PH VERT MULTI-POS OVHD SVC METER

120/240 OR 120/208V

NOTES:**APPLICATION:**

- THIS STANDARD DESCRIBES THE REQUIREMENTS FOR THE INSTALLATION OF AN INDOOR AND/OR OUTDOOR SELF CONTAINED, VERTICAL OR ALL-IN-ONE TYPE, MULTI-POSITION METER CONNECTION DEVICE, 1-PHASE, 3-WIRE 120/240 OR 120/208V.

INFORMATION:

- FOR THE INSTALLATION OF A VERTICAL TYPE, MULTI-POSITION METER PANEL, CUSTOMER TO FURNISH, INSTALL AND MAINTAIN THE FOLLOWING EQUIPMENT (SEE FIGURE 1):

A - METER CONNECTION DEVICE PANEL (2 THROUGH 4 VERTICAL POSITIONS) WITH DISCONNECTING MEANS BELOW EACH METER SOCKET (200 AMPERES MAXIMUM PER METER POSITION). IF NEW METER CONNECTION DEVICE PANEL IS REQUIRED, IT MUST BE FROM THE ComEd APPROVED METER FITTING CATALOG.

C - TAP BOX OR MAIN DISCONNECT DEVICE FOR TERMINATION OF SECONDARY CABLES. THIS DEVICE IS INTERNALLY BUSSED TO METER PANELS.

E - CONDUIT AND CONDUCTORS (OR SERVICE ENTRANCE CABLE WHERE PERMITTED BY LOCAL CODE) ON LINE SIDE OF TAP BOX OR MAIN DISCONNECT DEVICE - SERVICE RUN.

G - CONDUIT AND CONDUCTORS (OR SERVICE ENTRANCE CABLE WHERE PERMITTED BY LOCAL CODE) ON LOAD SIDE OF METER PANEL - SERVICE ENTRANCE.

H - GROUND CONNECTION PER LOCAL CODE, IF REQUIRED.

J - INSULATED METALLIC BUSHING ON LINE AND LOAD CONDUITS.

K - NEUTRAL TERMINAL.

L - FIFTH TERMINAL WITH POTENTIAL TAP (#12 COPPER WIRE OR EQUIVALENT) FROM NEUTRAL TERMINAL (120/208V SERVICE ONLY).

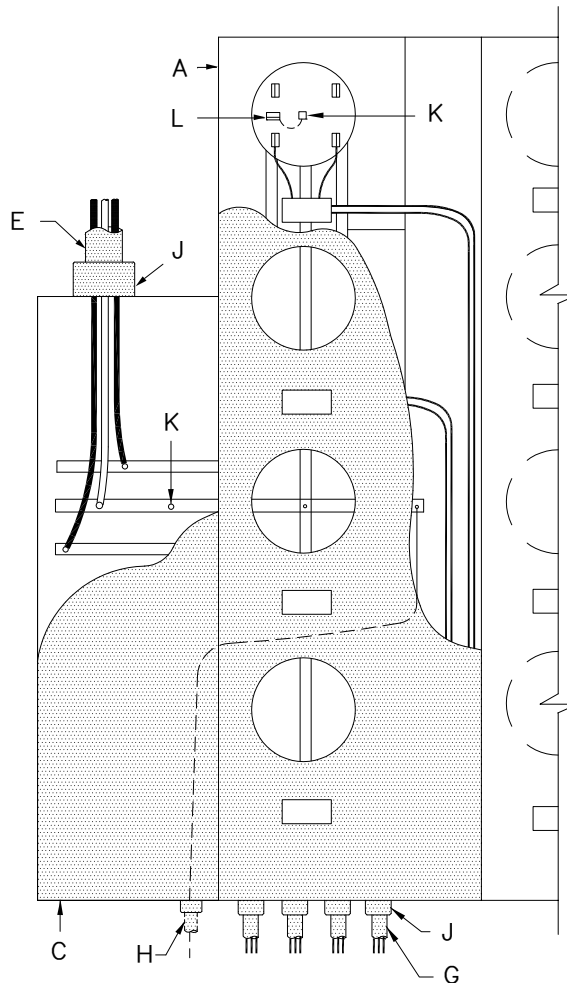

FIGURE 1

INDOOR/OUTDOOR
VERTICAL MULTI-POSITION 200A MAX.

ACAD

2. FOR THE INSTALLATION OF AN ALL-IN-ONE TYPE, MULTI-POSITION METER PANEL, CUSTOMER TO FURNISH, INSTALL AND MAINTAIN THE FOLLOWING EQUIPMENT (SEE FIGURE 2):

B - METER CONNECTION DEVICE PANEL (2 THROUGH 6 POSITIONS; ALL-IN-ONE TYPE) WITH DISCONNECTING MEANS BELOW EACH METER SOCKET (200 AMPERES MAXIMUM PER METER POSITION). IF NEW METER CONNECTION DEVICE PANEL IS REQUIRED, IT MUST BE FROM THE ComEd APPROVED METER FITTING CATALOG.

D - HORIZONTAL MAIN BUS BARS (FACTORY INSTALLED) FOR PHASE AND NEUTRAL CONNECTIONS.

F - CONDUIT AND CONDUCTORS (OR SERVICE ENTRANCE CABLE WHERE PERMITTED BY LOCAL CODE) ON LINE SIDE OF PANEL - SERVICE RUN.

G - CONDUIT AND CONDUCTORS (OR SERVICE ENTRANCE CABLE WHERE PERMITTED BY LOCAL CODE) ON LOAD SIDE OF METER PANEL - SERVICE ENTRANCE.

H - GROUND CONNECTION PER LOCAL CODE, IF REQUIRED.

J - INSULATED METALLIC BUSHING ON LINE AND LOAD CONDUITS.

K - NEUTRAL TERMINAL.

L - FIFTH TERMINAL WITH POTENTIAL TAP (#12 COPPER WIRE OR EQUIVALENT) FROM NEUTRAL TERMINAL (120/208V SERVICE ONLY).

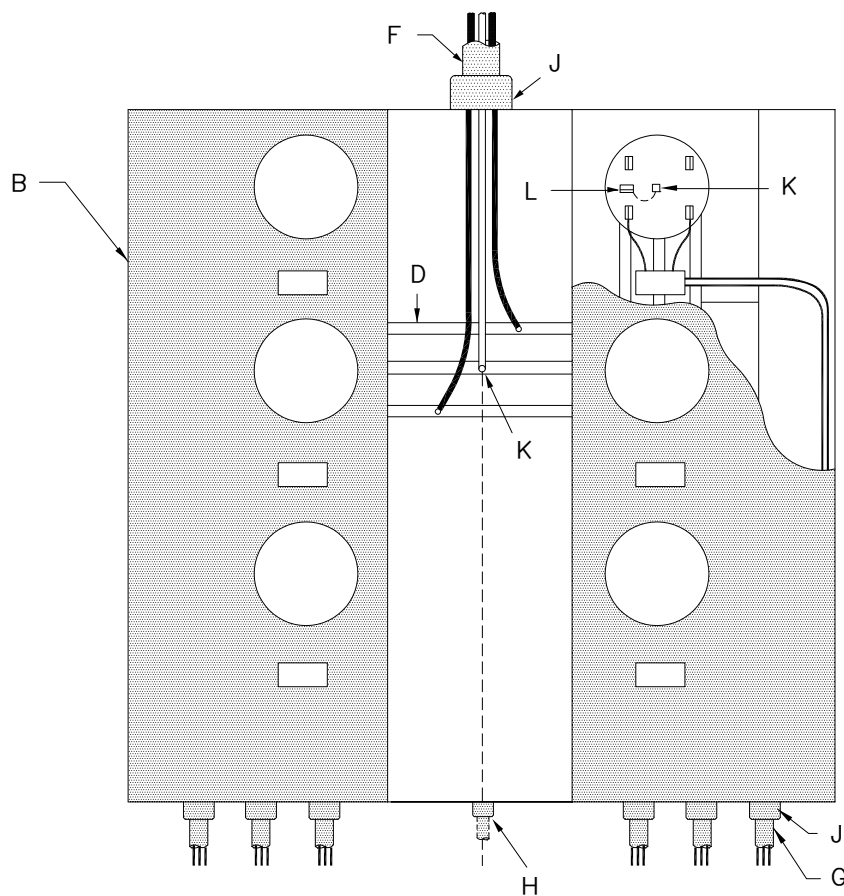

FIGURE 2

OUTDOOR ALL-IN-ONE TYPE
MULTI-POSITION, 200A MAX.

200A 1-PHASE UNDG SERVICE METER

120/240 OR 120/208V

NOTES:APPLICATION:

- THIS STANDARD DESCRIBES THE REQUIREMENTS FOR THE INSTALLATION OF AN OUTDOOR SELF CONTAINED, SINGLE OR DOUBLE POSITION, OR MOBILE HOME TYPE, COMBINATION METER CONNECTION DEVICE AND RACEWAY, RACEWAY AND PEDESTAL, 1-PHASE, 3-WIRE 120/240 OR 120/208V.

INFORMATION:

- FOR BOTH FRONT AND REAR LOT CABLE SYSTEM, THE SERVICE CABLE FROM THE TRANSFORMER OR SERVICE PEDESTAL TO THE RESIDENCE SHALL BE ROUTED PARALLEL TO LOT LINES. THE STANDARD LOCATION OF THE METER RACEWAY SHALL BE ON THE SIDE OF HOUSE CLOSEST TO THE TRANSFORMER OR SERVICE PEDESTAL.
- FOR THE INSTALLATION OF SINGLE OR DOUBLE POSITION COMBINATION METER CONNECTION DEVICE AND RACEWAY, 1-PHASE, 3-WIRE, CUSTOMER TO FURNISH, INSTALL AND MAINTAIN THE FOLLOWING EQUIPMENT (SEE FIGURE 1):

A - SINGLE OR DOUBLE POSITION COMBINATION METER CONNECTION DEVICE AND RACEWAY (200 AMPERES MAXIMUM PER METER POSITION). IF NEW METER CONNECTION DEVICE IS REQUIRED, IT MUST BE FROM THE ComEd APPROVED METER FITTING CATALOG.

B - METER SOCKET LOAD WIRE TERMINALS.

C - NEUTRAL TERMINAL.

D - FIFTH TERMINAL WITH POTENTIAL TAP (#12 COPPER WIRE OR EQUIVALENT) FROM NEUTRAL TERMINAL (120/208V SERVICE ONLY).

E - GROUND CONNECTION PER LOCAL CODE, IF REQUIRED.

F - COMPRESSION LUG CONNECTORS FOR PHASE AND NEUTRAL CABLES.

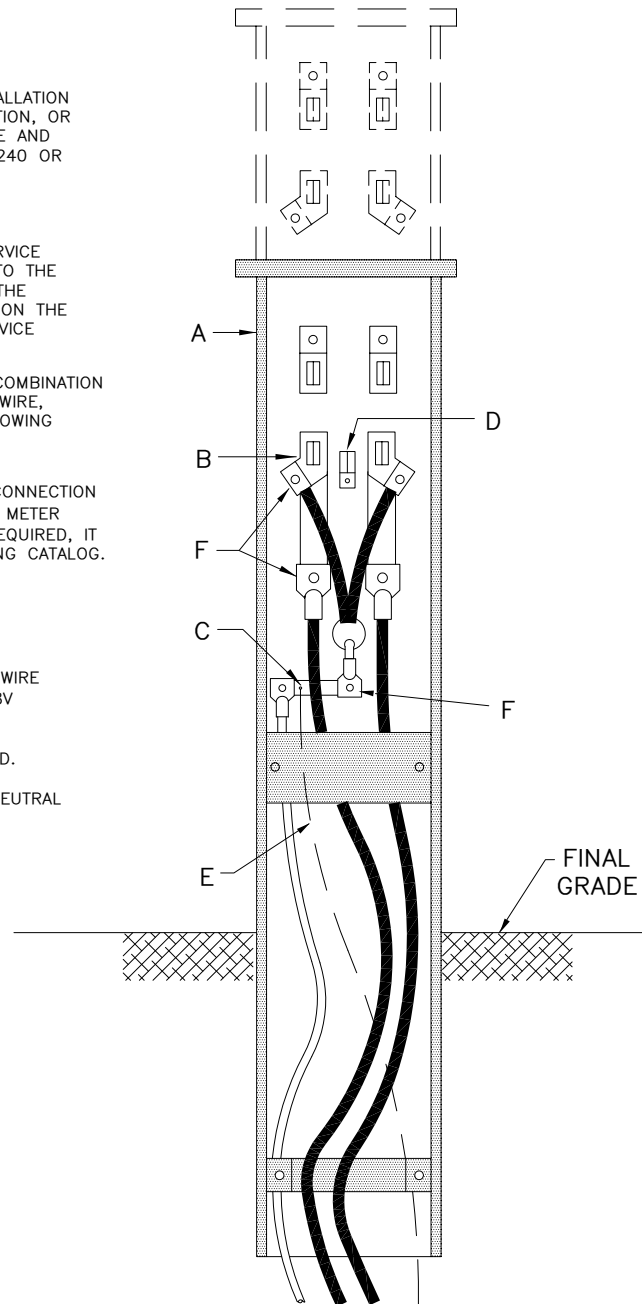
**FIGURE 1**

OUTDOOR
SINGLE OR DOUBLE POSITION
COMBINATION METER CONNECTION DEVICE
AND RACEWAY, 1-PHASE,
3-WIRE, 200A MAX.

ACAD

INFORMATION (CONT'D)

3. FOR THE INSTALLATION OF OUTDOOR SINGLE POSITION, MOBILE HOME TYPE, COMBINATION METER CONNECTION DEVICE, RACEWAY AND PEDESTAL, 1-PHASE, 3-WIRE, CUSTOMER TO FURNISH, INSTALL AND MAINTAIN THE FOLLOWING EQUIPMENT (SEE FIGURE 2):

E - GROUND CONNECTION PER LOCAL CODE, IF REQUIRED.

F - COMBINATION METER CONNECTION DEVICE, RACEWAY AND PEDESTAL (200 AMPERES MAXIMUM). IF NEW COMBINATION METER CONNECTION DEVICE IS REQUIRED, IT MUST BE FROM THE ComEd APPROVED METER FITTING CATALOG.

G - METER CONNECTION DEVICE.

H - ENCLOSURE FOR DISCONNECTING DEVICE AND RECEPTACLES.

J - BLOCK FOR TERMINATING SECONDARY SERVICE CABLES.

K - CONDUCTORS OR BUS EXTENDING FROM TERMINATING BLOCK TO METER SOCKET LINE TERMINALS.

L - STABILIZER FOOT (#10 GAUGE METAL) or 9" x 12" x 15" CONCRETE ANCHOR.

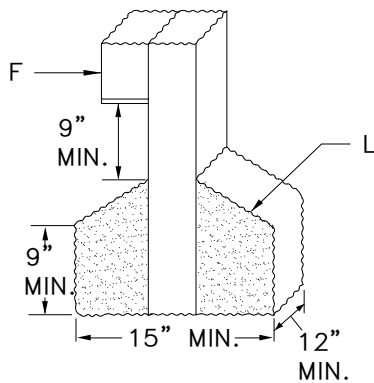

DETAIL-1

CONCRETE ANCHOR

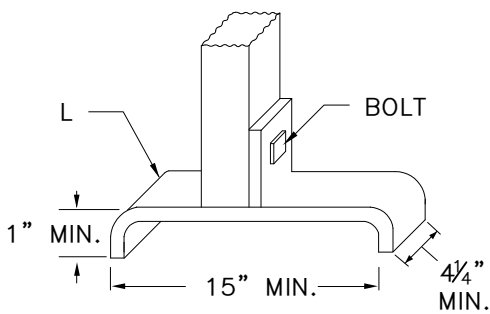

DETAIL-2

STABILIZER FOOT

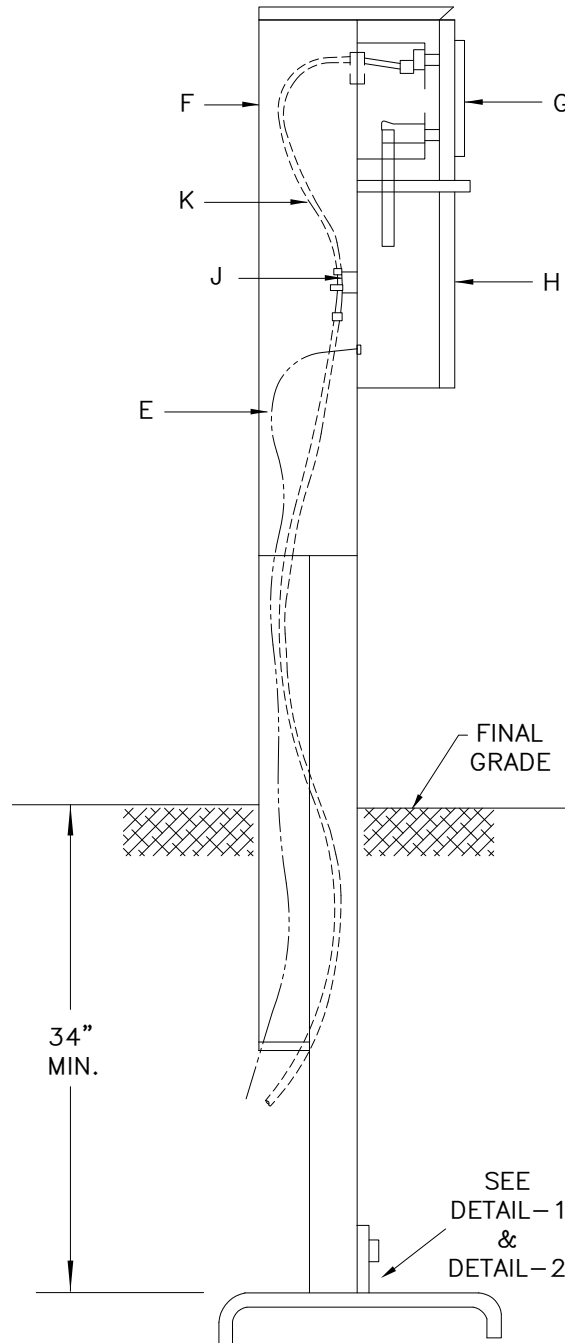

FIGURE 2

OUTDOOR SINGLE POSITION, MOBILE HOME TYPE, COMBINATION METER CONNECTION DEVICE, RACEWAY AND PEDESTAL, 1-PHASE, 3-WIRE, 200A MAX.

320A 1-PHASE UNDG SERVICE METER

120/240V

NOTES:**APPLICATION:**

- THIS STANDARD DESCRIBES THE REQUIREMENTS FOR THE INSTALLATION OF AN OUTDOOR SELF-CONTAINED, SINGLE POSITION, COMBINATION METER CONNECTION DEVICE AND RACEWAY, 1-PHASE, 3-WIRE 120/240V.

INFORMATION:

- FOR BOTH FRONT AND REAR LOT CABLE SYSTEMS, THE SERVICE CABLE FROM THE TRANSFORMER OR SERVICE PEDESTAL TO THE RESIDENCE SHALL BE ROUTED PARALLEL TO LOT LINES. THE STANDARD LOCATION OF THE METER RACEWAY SHALL BE ON THE SIDE OF THE HOUSE CLOSEST TO THE TRANSFORMER OR SERVICE PEDESTAL.
- CUSTOMER TO FURNISH, INSTALL AND MAINTAIN THE FOLLOWING EQUIPMENT (SEE FIGURE 1):
 - A - COMBINATION METER CONNECTION DEVICE AND RACEWAY WITH LEVER ACTUATED BY-PASS (320 AMPERES MAXIMUM). IF NEW COMBINATION METER CONNECTION DEVICE AND RACEWAY IS REQUIRED, IT MUST BE FROM THE ComEd APPROVED METER FITTING CATALOG.
 - B - COMPRESSION LUG CONNECTORS FOR LOAD CONDUCTORS.
 - C - NEUTRAL TERMINAL.
 - D - GROUND CONNECTION PER LOCAL CODE, IF REQUIRED.
 - E - BY-PASS LEVER.

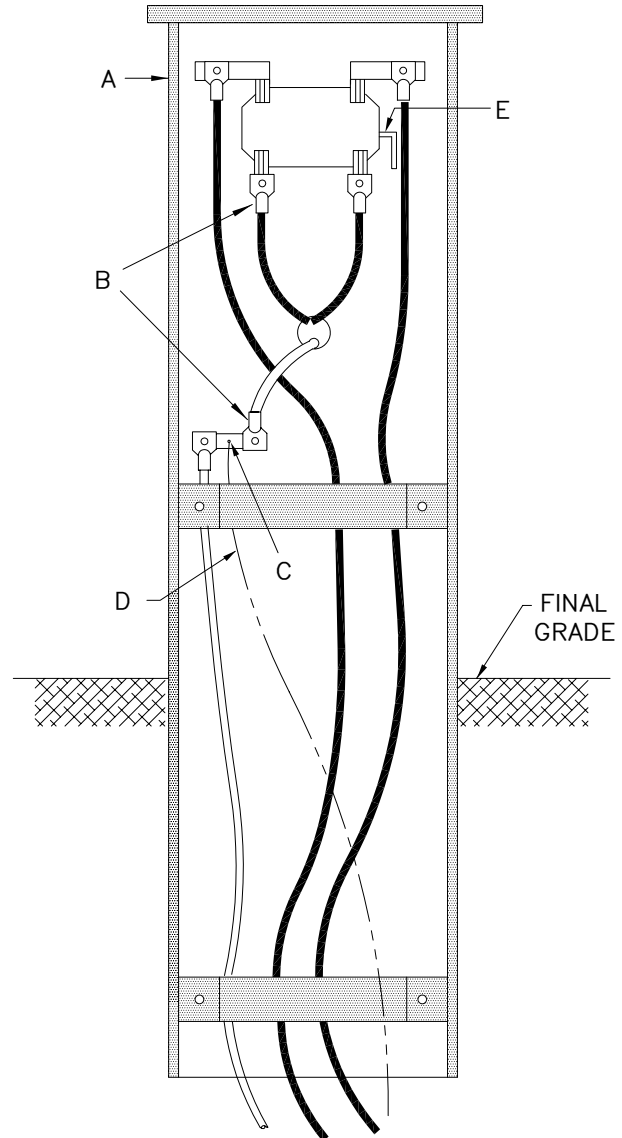
**FIGURE 1**

OUTDOOR
1-PHASE, 3-WIRE,
120/240V, 320A MAX.

This page intentionally left blank

200A 1-PH MULTI-POS UNDG SERVICE METER

120/240 OR 120/208V

NOTES:

APPLICATION:

- THIS STANDARD DESCRIBES THE REQUIREMENTS FOR THE INSTALLATION OF AN OUTDOOR, SELF-CONTAINED, MULTIPLE POSITION, COMBINATION METER CONNECTION DEVICE AND RACEWAY, 1-PHASE, 3-WIRE 120/240 OR 120/208V UNDERGROUND SERVICE METER.

INFORMATION:

1. FOR BOTH FRONT AND REAR LOT CABLE SYSTEMS, THE SERVICE CABLE FROM THE TRANSFORMER OR SERVICE PEDESTAL TO THE RESIDENCE SHALL BE ROUTED PARALLEL TO LOT LINES. THE STANDARD LOCATION OF THE METER RACEWAY SHALL BE ON THE SIDE OF THE HOUSE CLOSEST TO THE TRANSFORMER OR SERVICE PEDESTAL.
2. FOR THE INSTALLATION OF SELF-CONTAINED, MULTIPLE POSITION, COMBINATION METER CONNECTION DEVICE AND RACEWAY, INCLUDING ALL-IN-ONE TYPE, CUSTOMER TO FURNISH, INSTALL AND MAINTAIN THE FOLLOWING EQUIPMENT (SEE FIGURE 1 & FIGURE 2):
 - A - METER CONNECTION DEVICE PANEL (2 THROUGH 6 POSITION, 200 AMPERES MAXIMUM PER METER POSITION).
ALL-IN-ONE TYPE CONTAINS DISCONNECTING MEANS BELOW EACH METER SOCKET. IF NEW METER CONNECTION DEVICE PANEL IS REQUIRED, IT MUST BE FROM THE ComEd APPROVED METER FITTING CATALOG.
 - B - UNDERGROUND SERVICE RACEWAY.
 - C - HORIZONTAL MAIN BUS BARS (FACTORY INSTALLED) EQUIPPED WITH STUDS FOR ACCEPTING COMPRESSION LUG CONNECTORS.
 - D - CONDUIT AND CONDUCTORS (OR SERVICE ENTRANCE CABLE WHERE PERMITTED BY LOCAL CODE) ON LOAD SIDE OF METER PANEL - SERVICE ENTRANCE.
 - E - GROUND CONNECTION PER LOCAL CODE, IF REQUIRED.
 - F - INSULATED METALLIC BUSHING ON LOAD CONDUITS.
 - G - NEUTRAL TERMINAL.
 - H - FIFTH TERMINAL WITH POTENTIAL TAP (#12 COPPER WIRE OR EQUIVALENT) FROM NEUTRAL TERMINAL (120/208V SERVICE ONLY).

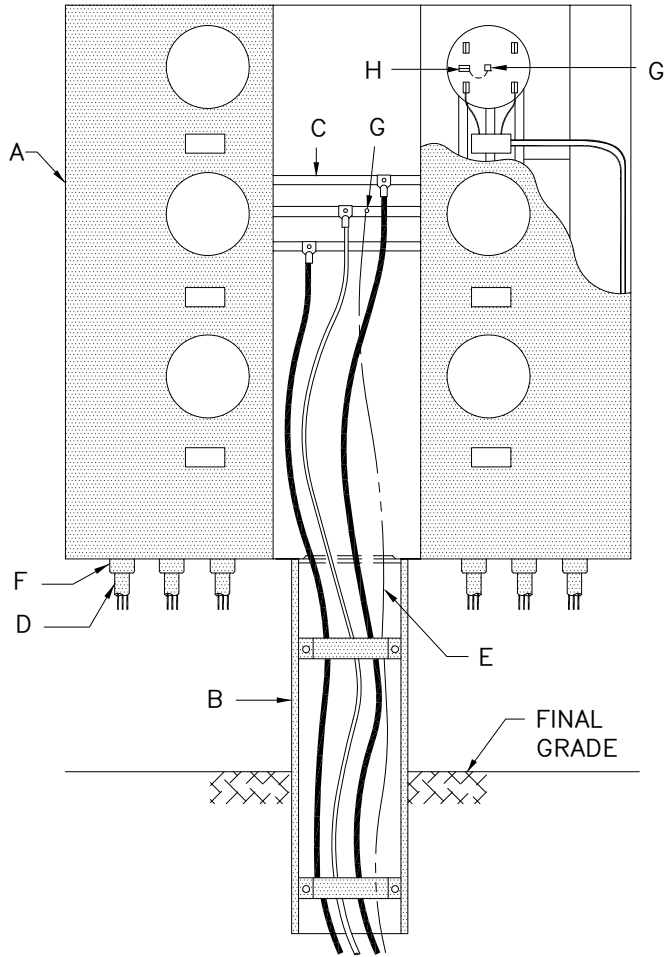

FIGURE 1
 ALL-IN-ONE TYPE
 1-PHASE, 3-WIRE
 120/240 OR 120/208V

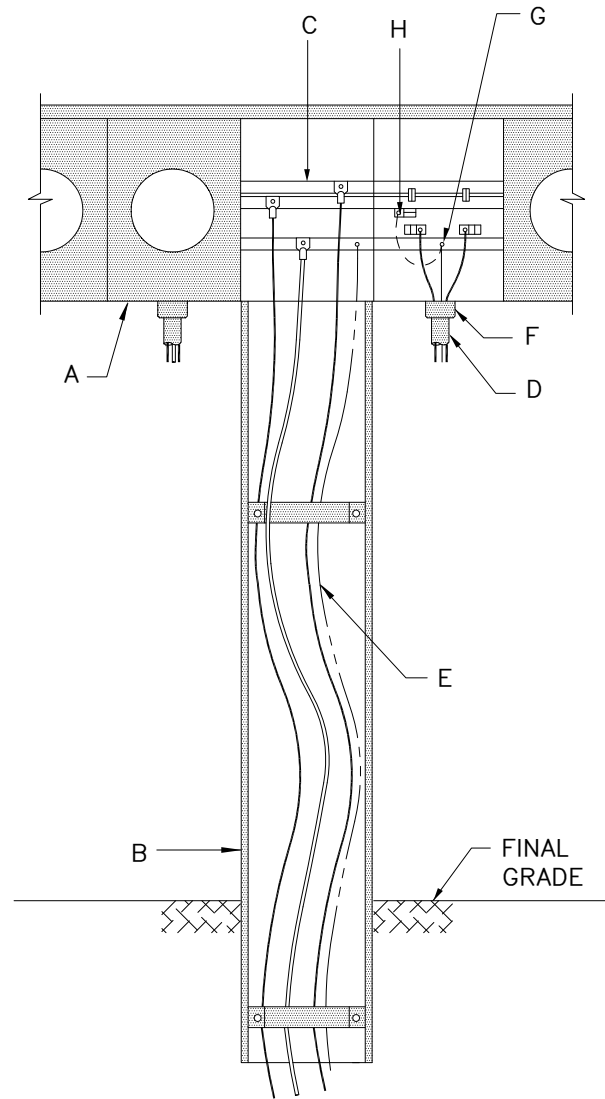

FIGURE 2
 1-PHASE, 3-WIRE
 120/240 OR 120/208V

200A 3-PHASE OVERHEAD SERVICE METER

120/240, 120/208, 277/480 OR 480V

NOTES:

APPLICATION:

- THIS STANDARD DESCRIBES THE REQUIREMENTS FOR THE INSTALLATION OF AN OUTDOOR SELF CONTAINED, SINGLE POSITION, METER CONNECTION DEVICE, 3-PHASE, 3-WIRE, 480V UNGROUNDED OR GROUNDED PHASE, OR 3-PHASE, 4-WIRE DELTA 120/240V OR WYE 120/208 OR 277/480V.

INFORMATION:

- FOR THE INSTALLATION OF A 3-PHASE, 3-WIRE, 480V UNGROUNDED OR GROUNDED PHASE OVERHEAD SERVICE METER, CUSTOMER TO FURNISH, INSTALL AND MAINTAIN THE FOLLOWING EQUIPMENT (SEE FIGURE 1):

- | | |
|--|--|
| A - METER CONNECTION DEVICE WITH LEVER ACTUATED BY-PASS (200 AMPERES MAXIMUM). IF A NEW METER CONNECTION DEVICE IS REQUIRED, IT MUST BE FROM THE ComEd APPROVED METER FITTING CATALOG. | E - TERMINAL FOR CONNECTION GROUNDED PHASE. |
| B - CONDUIT AND CONDUCTORS ON LINE SIDE OF METER - SERVICE RUN. | F - WIRE OR BUS BETWEEN TERMINALS "D" AND "E" (REQUIRED ONLY IF SUPPLY INCLUDES GROUNDED PHASE CONDUCTOR). |
| C - CONDUIT AND CONDUCTORS ON LOAD SIDE OF METER - SERVICE ENTRANCE. | G - DISCONNECTING LINK (CENTER PHASE ONLY). |
| D - TERMINAL FOR CONNECTION OF GROUNDED PHASE. IF NO GROUNDED PHASE, THEN ANY PHASE. | H - GROUND CONNECTION PER LOCAL CODE, IF REQUIRED. |
| | J - INSULATED METALLIC BUSHING ON LINE AND LOAD CONDUITS. |
| | K - BY-PASS LEVER. |

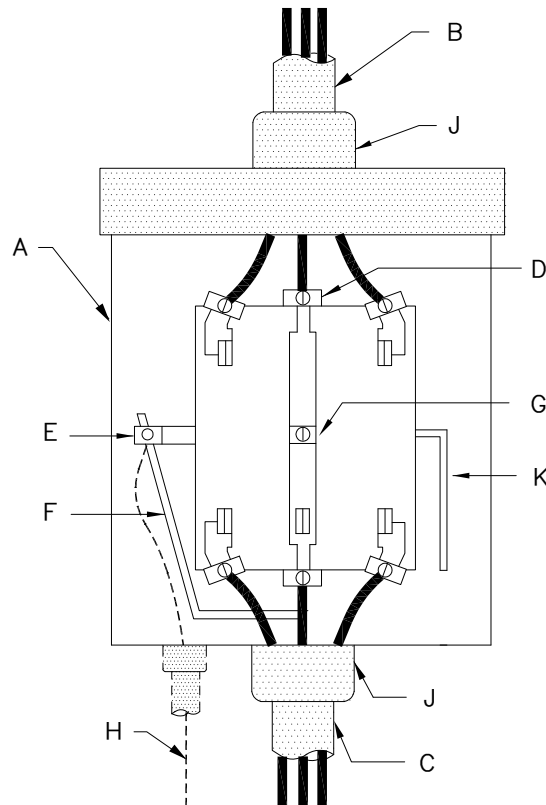

FIGURE 1

3-PHASE, 3-WIRE,
480V UNGROUNDED OR GROUNDED PHASE
OVERHEAD SERVICE METER

2. FOR THE INSTALLATION OF A 3-PHASE, 4-WIRE DELTA 120/240V OR 3-PHASE, 4-WIRE WYE 120/208V OR 277/480V OVERHEAD SERVICE METER, CUSTOMER TO FURNISH, INSTALL AND MAINTAIN THE FOLLOWING EQUIPMENT (SEE FIGURE 2):

- | | |
|--|---|
| <p>A - METER CONNECTION DEVICE WITH LEVER ACTUATED BY-PASS (200 AMPERES MAXIMUM). IF A NEW METER CONNECTION DEVICE IS REQUIRED, IT MUST BE FROM THE ComEd APPROVED METER FITTING CATALOG.</p> <p>B - CONDUIT AND CONDUCTORS ON LINE SIDE OF METER - SERVICE RUN.</p> <p>C - CONDUIT AND CONDUCTORS ON LOAD SIDE OF METER - SERVICE ENTRANCE.</p> <p>H - GROUND CONNECTION PER LOCAL CODE, IF REQUIRED.</p> | <p>J - INSULATED METALLIC BUSHING ON LINE AND LOAD CONDUITS.</p> <p>K - BY-PASS LEVER.</p> <p>L - NEUTRAL TERMINAL.</p> <p>M - WIRE OR BUS BETWEEN NEUTRAL TERMINAL AND METER SOCKET NEUTRAL TERMINAL.</p> <p>N - TERMINAL FOR CONNECTION OF HIGH-PHASE ON DELTA SUPPLY. IF SUPPLY IS WYE, ANY PHASE.</p> |
|--|---|

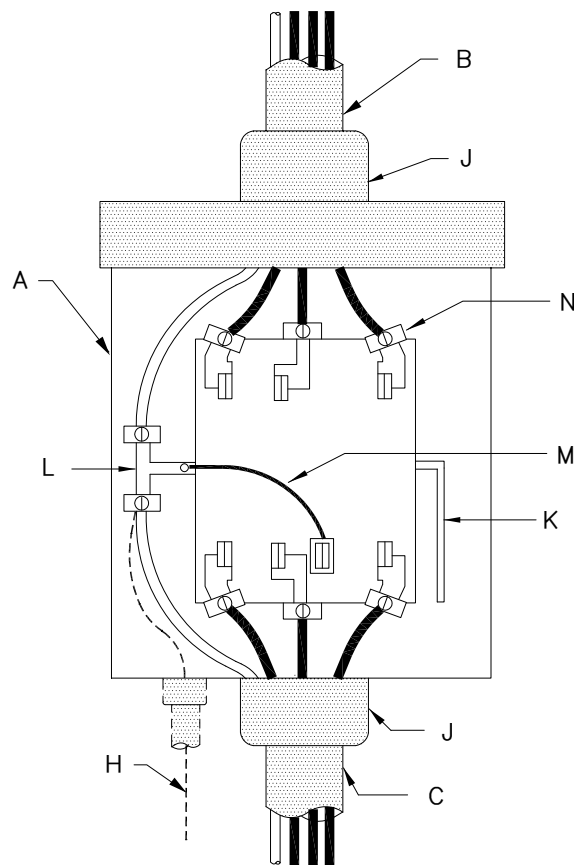

FIGURE 2

3-PHASE, 4-WIRE DELTA 120/240V
OR
3-PHASE, 4-WIRE 120/208 OR 277/480V
OVERHEAD SERVICE METER

200A 3-PHASE MULTI-POS OVHD SERVICE METER

OUTDOOR

120/240, 120/208 OR 277/480V

NOTES:

APPLICATION:

- THIS STANDARD DESCRIBES THE REQUIREMENTS FOR THE INSTALLATION OF AN OUTDOOR, SELF-CONTAINED, MULTIPLE POSITION METER CONNECTION DEVICE, 3-PHASE, 4-WIRE DELTA 120/240V OR 3-PHASE, 4-WIRE WYE 120/208V OR 277/480V.

INFORMATION:

1. CUSTOMER TO FURNISH, INSTALL AND MAINTAIN THE FOLLOWING EQUIPMENT:

- | | |
|--|--|
| <p>A METER CONNECTION DEVICE (2 THROUGH 4 POSITIONS WITH LEVER ACTUATED BY-PASSES; 200 AMPERES MAXIMUM PER METER POSITION). NEW METER CONNECTION DEVICE MUST BE FROM ComEd APPROVED METER FITTING CATALOG.</p> <p>B CONDUIT AND CONDUCTORS ON LINE SIDE OF METER PANEL - SERVICE RUN.</p> <p>C HORIZONTAL MAIN BUS BARS (FACTORY INSTALLED) FOR PHASE AND NEUTRAL CONNECTIONS.</p> <p>D CONDUIT AND CONDUCTORS ON LOAD SIDE OF METER PANEL - SERVICE ENTRANCE.</p> | <p>E INSULATED METALLIC BUSHING ON LINE AND LOAD CONDUITS.</p> <p>F NEUTRAL TERMINAL.</p> <p>G WIRE OR BUS BETWEEN NEUTRAL TERMINAL AND METER SOCKET NEUTRAL TERMINAL.</p> <p>H TERMINAL FOR CONNECTION OF HIGH-PHASE LINE ON A DELTA SUPPLY. IF SUPPLY IS WYE, ANY PHASE.</p> <p>J GROUND CONNECTION PER LOCAL CODE, IF REQUIRED.</p> <p>K BY-PASS LEVER.</p> |
|--|--|

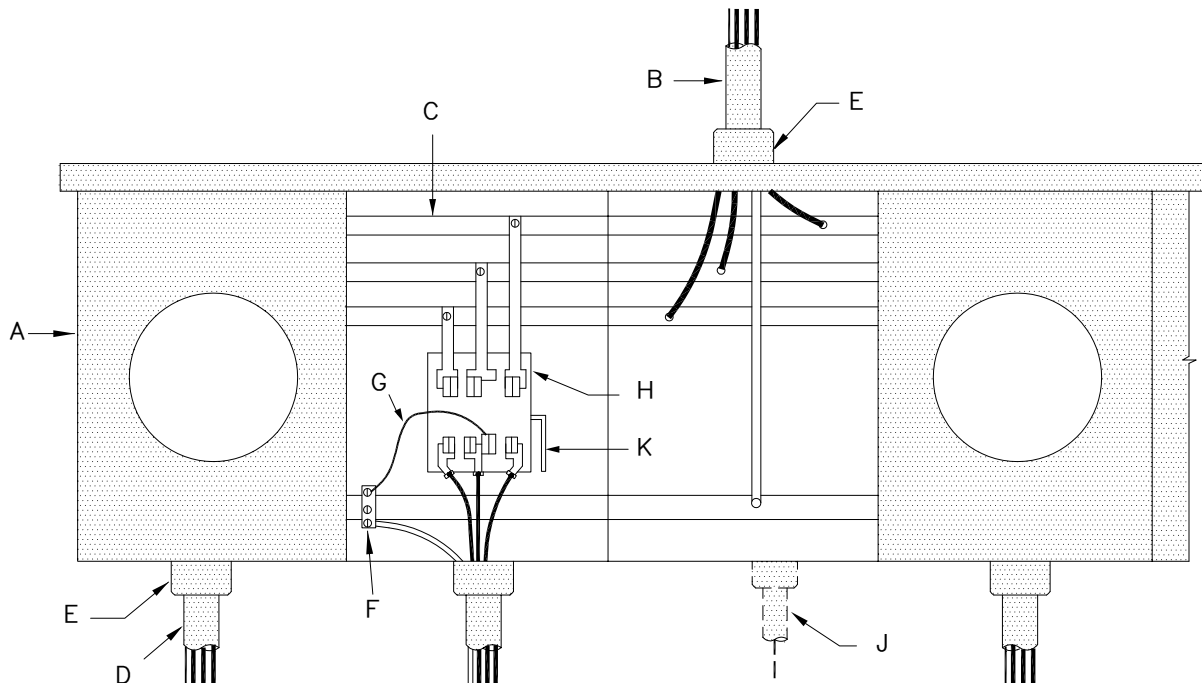

3-PHASE, 4-WIRE DELTA 120/240V
OR
3-PHASE, 4-WIRE WYE 120/208 OR 277/480V

This page intentionally left blank

200A 3-PH MULTI-POS OH/UG SERVICE METER

120/240, 120/208 OR 277/480V

NOTES:**APPLICATION:**

- THIS STANDARD DESCRIBES THE REQUIREMENTS FOR INSTALLATION OF AN OUTDOOR SELF-CONTAINED, MULTIPLE POSITION METER CONNECTION DEVICE, 3-PHASE, 4-WIRE DELTA 120/240V, OR A 3-PHASE, 4-WIRE WYE 120/208 OR 277/480V.

INFORMATION:

- FOR INSTALLATION OF A 3-PHASE, 4-WIRE DELTA 120/240V OR 3-PHASE, 4-WIRE WYE 120/208 OR 277/480V OVERHEAD OR UNDERGROUND SERVICE METER WITH A CABLE TAP BOX, CUSTOMER TO FURNISH, INSTALL AND MAINTAIN THE FOLLOWING EQUIPMENT (SEE FIGURE 1):

- | | |
|---|--|
| <p>A - METER CONNECTION DEVICE (2 THROUGH 6 POSITION WITH LEVER ACTUATED BY-PASSES; 200 AMPERES MAXIMUM PER METER POSITION). IF A NEW METER CONNECTION DEVICE IS REQUIRED, IT MUST BE FROM THE ComEd APPROVED METER FITTING CATALOG.</p> <p>B - TAP BOX WITH TERMINATING PADS FOR CONNECTION OF LINE CONDUCTORS.</p> <p>C - CONDUIT AND CONDUCTORS ON LINE SIDE OF TAP BOX - SERVICE RUN (IF APPLICABLE).</p> <p>D - CONDUIT AND CONDUCTORS BETWEEN TAP BOX AND METER CONNECTION DEVICE.</p> <p>E - CONDUIT AND CONDUCTORS ON LOAD SIDE OF METERS - SERVICE ENTRANCE.</p> | <p>F - INSULATED METALLIC BUSHING ON LINE AND LOAD CONDUITS.</p> <p>G - NEUTRAL TERMINAL.</p> <p>H - WIRE OR BUS BETWEEN NEUTRAL TERMINAL AND METER SOCKET NEUTRAL TERMINAL.</p> <p>J - TERMINAL FOR CONNECTION OF HIGH-PHASE ON A DELTA SUPPLY. IF SUPPLY IS WYE, ANY PHASE.</p> <p>K - GROUND CONNECTION PER LOCAL CODE, IF REQUIRED</p> <p>L - CONDUIT FOR UNDERGROUND SERVICE CONNECTION (IF APPLICABLE)</p> <p>M - BY-PASS LEVER.</p> |
|---|--|

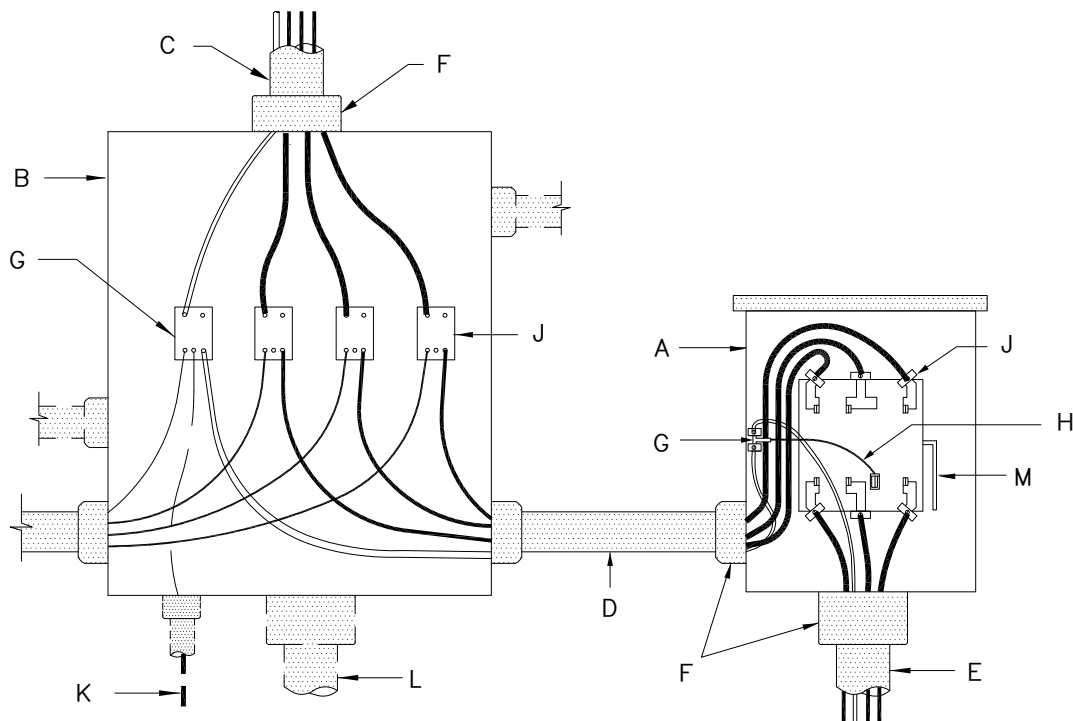

FIGURE 1
CABLE TAP BOX

ACAD

2. FOR INSTALLATION OF A 3-PHASE, 4-WIRE DELTA 120/240V OR 3-PHASE, 4-WIRE WYE 120/208 OR 277/480V OVERHEAD OR UNDERGROUND SERVICE METER WITH A CABLE ENTRY BOX, CUSTOMER TO FURNISH, INSTALL AND MAINTAIN THE FOLLOWING EQUIPMENT (SEE FIGURE 2):

A - METER CONNECTION DEVICE (2 THROUGH 6 POSITION WITH LEVER ACTUATED BY-PASSES; 200 AMPERES MAXIMUM PER METER POSITION). IF A NEW METER CONNECTION DEVICE IS REQUIRED, IT MUST BE FROM THE ComEd APPROVED METER FITTING CATALOG.

E - CONDUIT AND CONDUCTORS ON LOAD SIDE OF METERS - SERVICE ENTRANCE.

F - INSULATED METALLIC BUSHINGS ON LINE AND LOAD CONDUITS.

G - NEUTRAL TERMINAL.

H - WIRE OR BUS BETWEEN NEUTRAL TERMINAL AND METER SOCKET NEUTRAL TERMINAL.

J - TERMINAL FOR CONNECTION OF HIGH-PHASE ON DELTA SUPPLY. IF SUPPLY IS WYE, ANY PHASE.

K - GROUND CONNECTION PER LOCAL CODE, IF REQUIRED.

L - CONDUIT FOR UNDERGROUND SERVICE CONNECTION (IF APPLICABLE)

M - BY-PASS LEVER.

P - CABLE ENTRY BOX.

Q - CONDUIT AND CONDUCTORS ON LINE SIDE OF CABLE ENTRY BOX - SERVICE RUN, IF APPLICABLE.

R - ENCLOSED BUSWAY, INSTALLED ABOVE ALL METER CONNECTION DEVICES (MUST BE PROVIDED FOR MAXIMUM NUMBER OF METER POSITIONS).

S - CONDUCTORS BETWEEN ENCLOSED BUSWAY AND METER SOCKET LINE TERMINALS.

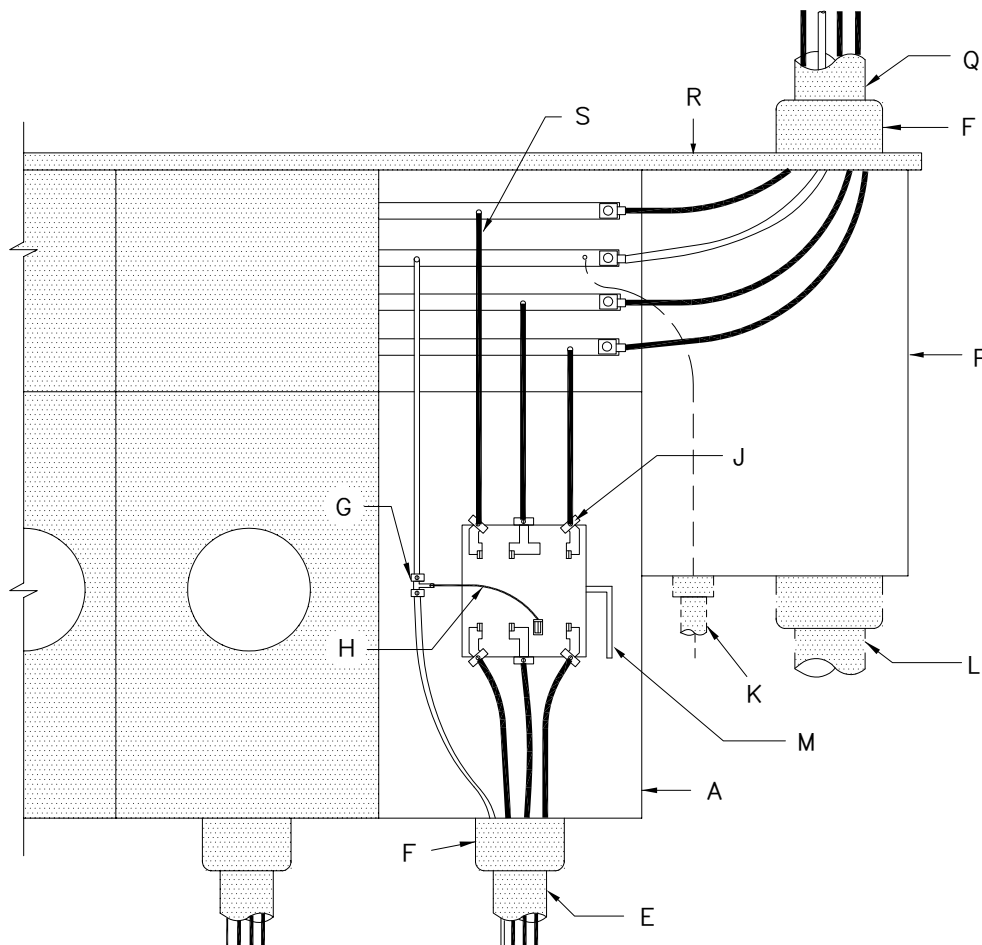

FIGURE 2
CABLE ENTRY BOX

ACAD

200A 3-PHASE UNDERGROUND SERVICE METER

120/208, 120/240, 277/480 OR 480V

NOTES:

APPLICATION:

- THIS STANDARD DESCRIBES THE REQUIREMENTS FOR THE INSTALLATION OF AN OUTDOOR SELF-CONTAINED, SINGLE POSITION COMBINATION METER CONNECTION DEVICE AND RACEWAY 3-PHASE, 3-WIRE 480V UNGROUNDED OR GROUNDED PHASE OR A 3-PHASE, 4-WIRE DELTA 120/240V OR 3-PHASE, 4-WIRE WYE 120/208 OR 277/480V UNDERGROUND SERVICE METER.

INFORMATION:

- FOR THE INSTALLATION OF A 3-PHASE, 3-WIRE, 480V GROUNDED OR UNGROUNDED PHASE UNDERGROUND SERVICE METER, CUSTOMER TO FURNISH, INSTALL AND MAINTAIN THE FOLLOWING EQUIPMENT (SEE FIGURE 1):

- A - COMBINATION METER CONNECTION DEVICE AND RACEWAY WITH LEVER ACTUATED BY-PASS (200 AMPERES MAXIMUM). IF A NEW METER CONNECTION DEVICE IS REQUIRED, IT MUST BE FROM THE ComEd APPROVED METER FITTING CATALOG.
- B - BLOCK FOR TERMINATING SERVICE CABLES.
- C - CABLE OR BUS (FACTORY INSTALLED) BETWEEN TERMINATING BLOCK TERMINAL AND METER SOCKET LINE TERMINALS.
- D - TERMINAL FOR GROUNDED PHASE. IF NO GROUNDED PHASE, THEN ANY PHASE.
- E - TERMINAL FOR CONNECTION OF GROUNDED PHASE.
- F - WIRE OR BUS BETWEEN THE TERMINALS "D" AND "E" (REQUIRED ONLY IF SUPPLY INCLUDES GROUNDED PHASE CONDUCTOR).
- G - DISCONNECTING LINK (CENTER PHASE ONLY).
- H - GROUND CONNECTION PER LOCAL CODE, IF REQUIRED.
- J - BY-PASS LEVER.

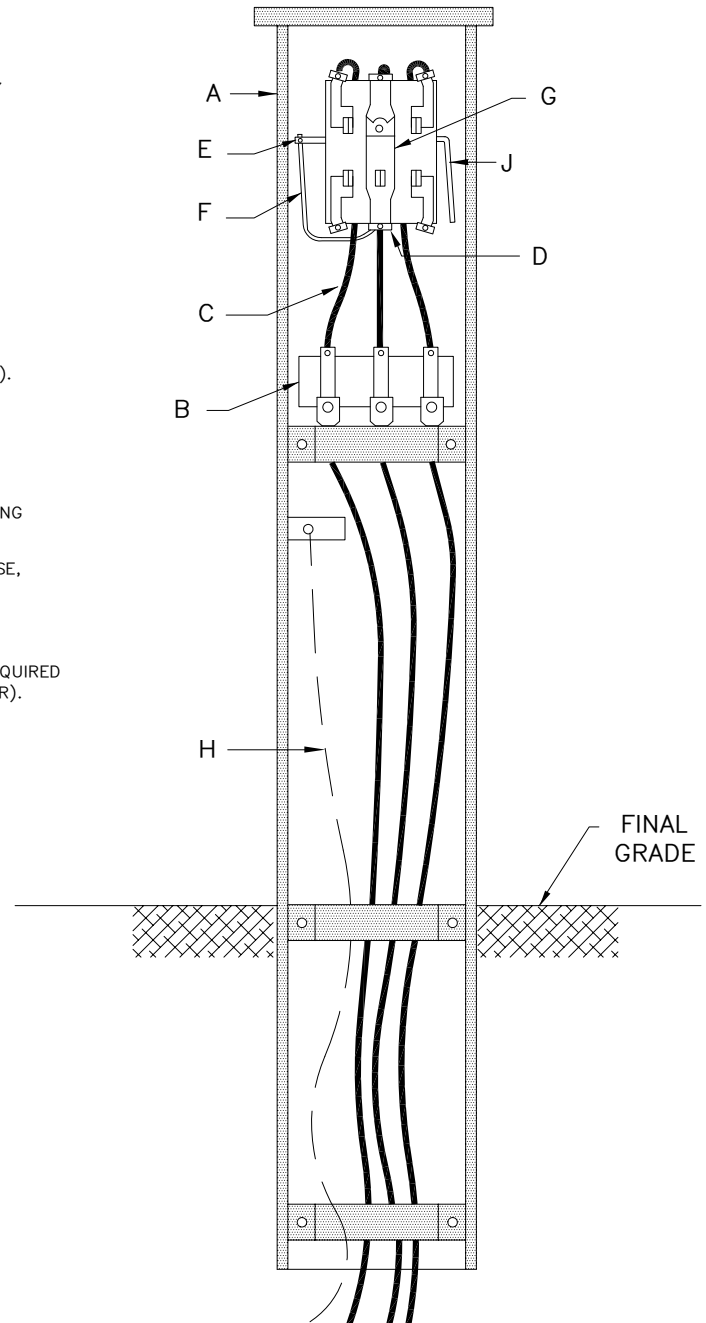

FIGURE 1

3-PHASE, 3-WIRE 480V UNGROUNDED OR GROUNDED PHASE UNDERGROUND SERVICE METER

2. FOR THE INSTALLATION OF A 3-PHASE, 4-WIRE, DELTA 120/240V OR A 3-PHASE, 4-WIRE WYE 120/208 OR 277/480V UNDERGROUND SERVICE METER, CUSTOMER TO FURNISH, INSTALL AND MAINTAIN THE FOLLOWING EQUIPMENT (SEE FIGURE 2):

- A - COMBINATION METER CONNECTION DEVICE AND RACEWAY WITH LEVER ACTUATED BY-PASS (200 AMPERES MAXIMUM). IF A NEW METER CONNECTION DEVICE IS REQUIRED, IT MUST BE FROM THE ComEd APPROVED METER FITTING CATALOG.
- B - BLOCK FOR TERMINATING SECONDARY SERVICE CABLES.
- C - CABLE OR BUS (FACTORY INSTALLED) BETWEEN TERMINATING BLOCK TERMINAL AND METER SOCKET LINE TERMINALS.
- H - GROUND CONNECTION PER LOCAL CODE, IF REQUIRED.
- J - BY-PASS LEVER.
- K - NEUTRAL TERMINAL.
- L - WIRE OR BUS BETWEEN NEUTRAL TERMINAL AND METER SOCKET NEUTRAL TERMINAL.
- M - TERMINAL CONNECTION OF HIGH PHASE ON A DELTA SUPPLY. IF SUPPLY IS WYE, ANY PHASE.

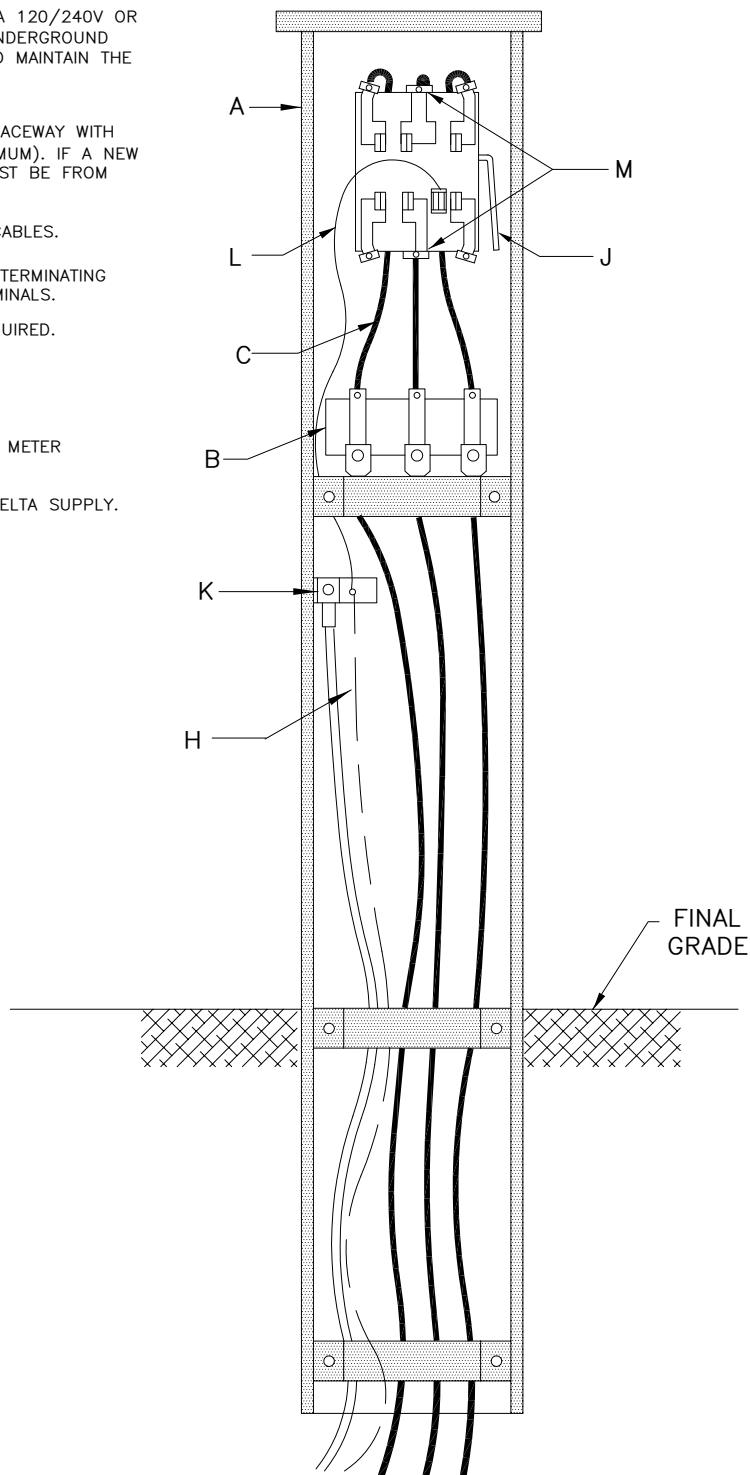

FIGURE 2

3-PHASE, 4-WIRE DELTA 120/240V
OR
3-PHASE, 4-WIRE WYE 120/208 OR 277/480V
UNDERGROUND SERVICE METER

200A 3-PHASE MULTI-POS UNDG SERVICE METER

120/240, 120/208 OR 277/480V

NOTES:

APPLICATION:

- THIS STANDARD DESCRIBES THE REQUIREMENTS FOR THE INSTALLATION AND CONNECTION OF AN OUTDOOR SELF-CONTAINED, MULTIPLE POSITION, COMBINATION METER CONNECTION DEVICE AND RACEWAY 3-PHASE, 4-WIRE DELTA 120/240V OR 3-PHASE, 4-WIRE 120/208 OR 277/480V.

INFORMATION:

- CUSTOMER TO FURNISH, INSTALL AND MAINTAIN THE FOLLOWING EQUIPMENT (SEE FIGURE 1):
 - COMBINATION METER CONNECTION DEVICE AND RACEWAY (2 THROUGH 4 POSITIONS) WITH LEVER ACTUATED BY-PASS; 200 AMPERES MAXIMUM PER METER POSITION. NEW METER CONNECTION DEVICE SHALL BE FROM ComEd APPROVED METER FITTING CATALOG.
 - UNDERGROUND SERVICE RACEWAY.
 - HORIZONTAL MAIN BUS BARS (FACTORY INSTALLED) EQUIPPED WITH STUDS FOR ACCEPTING COMPRESSION LUG CONNECTORS.
 - CONDUIT AND CONDUCTORS ON LOAD SIDE OF METER PANEL - SERVICE ENTRANCE.
 - INSULATED METALLIC BUSHING ON LINE AND LOAD CONDUITS.
 - NEUTRAL TERMINAL.
 - WIRE OR BUS BAR BETWEEN NEUTRAL TERMINAL AND METER SOCKET NEUTRAL TERMINAL.
 - TERMINAL FOR CONNECTION OF HIGH-PHASE LINE ON A DELTA SUPPLY. IF SUPPLY IS WYE, ANY PHASE.
 - GROUND CONNECTION PER LOCAL CODE, IF REQUIRED.
 - BY-PASS LEVER.

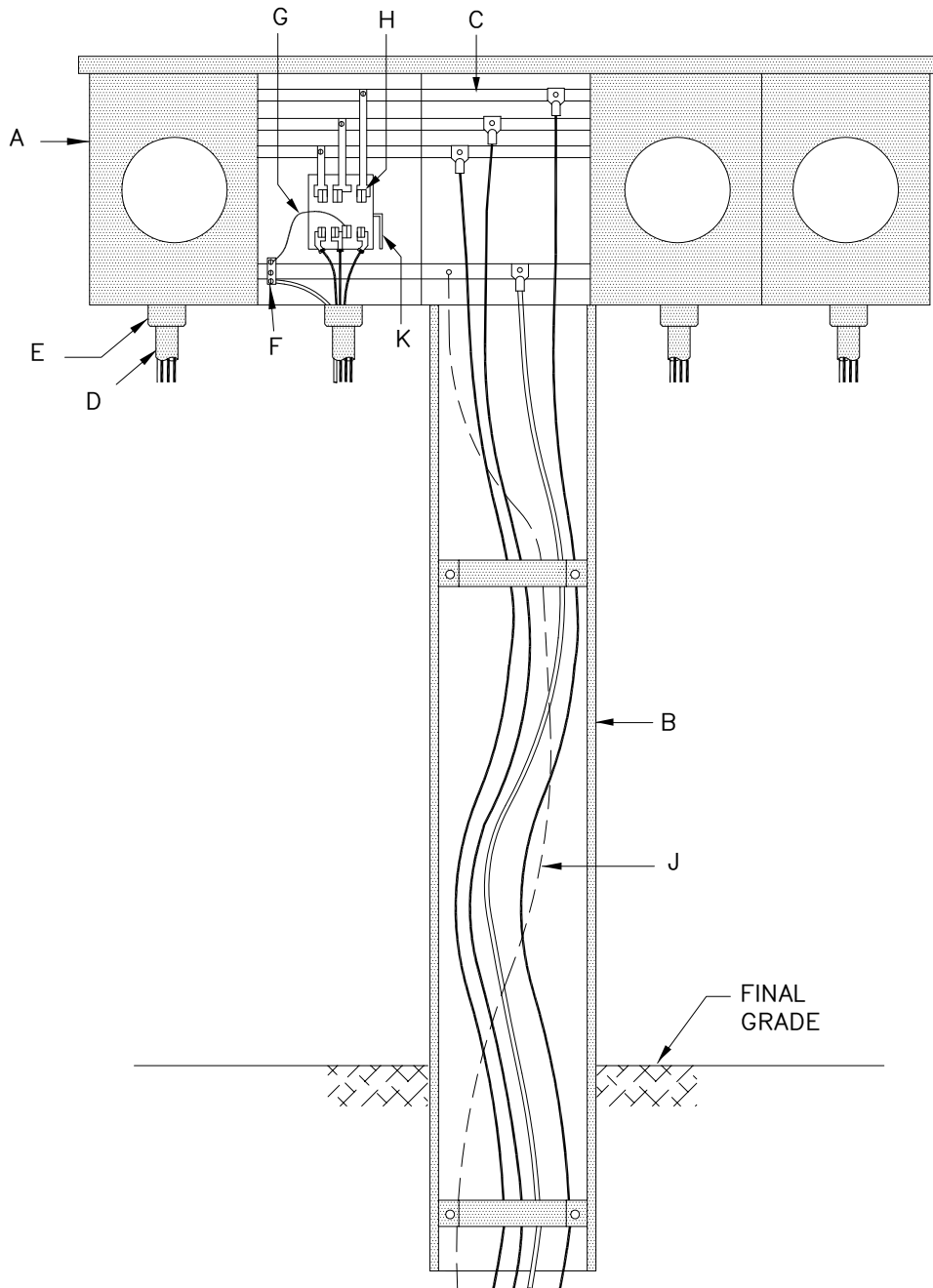

FIGURE 1

OUTDOOR SELF-CONTAINED, MULTIPLE POSITION
 COMBINATION METER CONNECTION DEVICE AND RACEWAY
 3-PHASE, 4-WIRE DELTA 120/240V
 OR
 3-PHASE, 4-WIRE WYE 120/208 OR 277/480V

CURRENT TRANSFORMER COMPARTMENT

480V OR LESS

NOTES:

APPLICATION:

- THIS STANDARD DESCRIBES THE REQUIREMENTS FOR THE CONSTRUCTION OF CURRENT TRANSFORMER COMPARTMENTS ≤ 800 AMPERES AND CURRENT TRANSFORMER COMPARTMENT LAMINATED BUS > 800 AMPERES, 480 VOLT OR LESS.

INFORMATION:

- FOR THE INSTALLATION OF ≤ 800 A CURRENT TRANSFORMER COMPARTMENT (SEE FIGURE 1), OR > 800 A LAMINATED BUS CURRENT TRANSFORMER COMPARTMENT (SEE FIGURE 2), CUSTOMER TO FURNISH, INSTALL AND MAINTAIN THE FOLLOWING EQUIPMENT:
 - CURRENT TRANSFORMER CABINET. CABINET SHALL COMPLY WITH THE "NATIONAL ELECTRIC CODE" AND BE APPROVED BY THE COMPANY PRIOR TO CONSTRUCTION. TRANSFORMER CABINET SHALL ALSO HAVE A HINGED DOOR WITH SEALING HASP (7/16" HOLE).
 - INSULATED MOUNTING BASE, 1" x 4" FASTENER TO MOUNTING BRACKETS.
 - MOUNTING BRACKETS FASTENED TO SIDES OR BACK OF CABINET.
 - BUS DETAIL DRILLED AND TAPPED FOR TRANSFORMER, LUG AND JUMPER BOLTS, AND #10-24 BUS POTENTIAL TAP SCREWS.
 - JUMPER BOLTS - 1/2".
 - TWO 1/2" TRANSFORMER MOUNTING BOLTS SPACED ON 1-3/8" CENTERS AT EACH END OF CURRENT TRANSFORMER.
 - LUG BOLTS - 1/2".
 - LUG(S) FOR CABLE CONNECTION.
 - CENTER POSITION - (NOT REQUIRED IF SERVICE IS SINGLE PHASE, THREE-WIRE. FOR THREE-PHASE, THREE-WIRE SERVICE.) A BUS DETAIL IS REQUIRED WITH PROVISIONS FOR CABLE CONNECTION LUGS AND A #10-24 BUS POTENTIAL TAP SCREW. FOR 3-PHASE, 4-WIRE SERVICE, BUS DETAILS (ITEM "D") AND THE HARDWARE FOR INSTALLATION OF A CURRENT TRANSFORMER ARE REQUIRED.
 - BUS DETAIL FOR NEUTRAL OR GROUNDED CONDUCTOR DRILLED AND TAPPED FOR LUG BOLTS AND A #10-24 NEUTRAL TAP SCREW.
 - HOLE THREADED FOR #10-24 BUS POTENTIAL AND NEUTRAL TAP SCREWS.
 - LAMINATED BUS INSTALLED EDGE WISE TOWARD THE FRONT (SEE DETAIL-B FOR DRILLING PATTERN). QUANTITY OF BUS LAMINATIONS DEPENDS ON CURRENT RATING OF COMPARTMENT (SEE DETAIL-A).
 - BOLTS AND RELATED HARDWARE FOR MOUNTING CURRENT TRANSFORMERS.
- ComEd TO FURNISH, INSTALL AND MAINTAIN, OR ComEd TO FURNISH AND MAINTAIN, CUSTOMER TO INSTALL:
 - CURRENT TRANSFORMERS AND WIRING IN ACCORDANCE WITH STANDARD C9150.

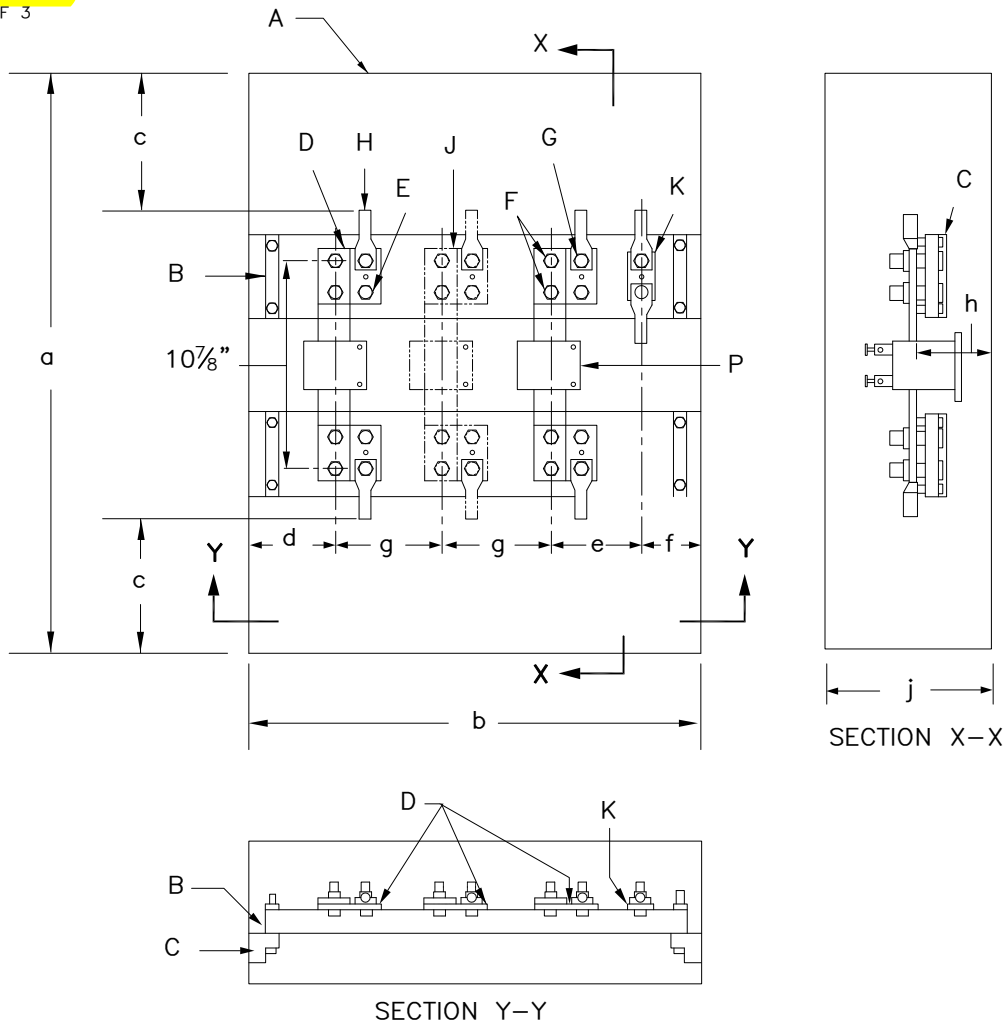

FIGURE 1
CURRENT TRANSFORMER COMPARTMENT
▶ ≤800 AMPERES

*MINIMUM DIMENSIONS (INCHES)

a	b	c	d	e	f	g	h	j
40	24	11	3 3/4	6 1/4	2 1/2	6	3 3/4	8

*THESE DIMENSIONS APPLY TO BOTH SINGLE AND 3-PHASE CURRENT TRANSFORMER COMPARTMENTS.

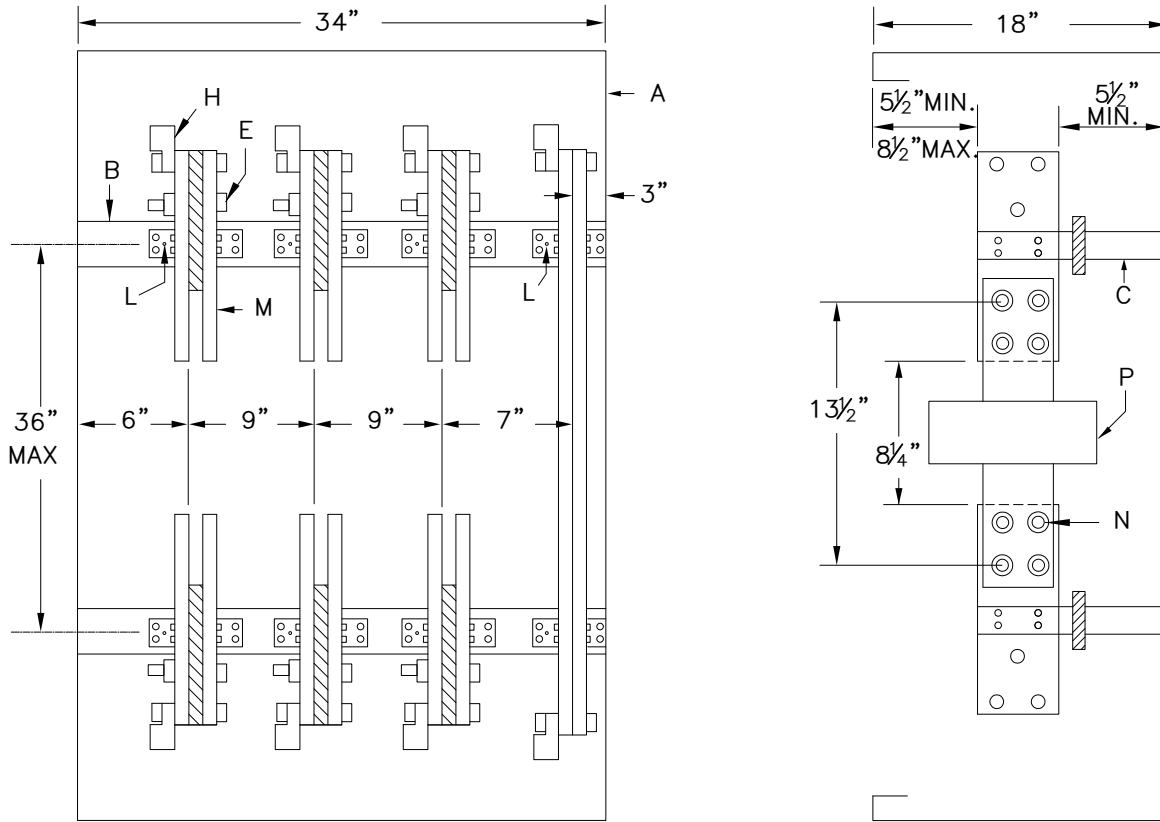
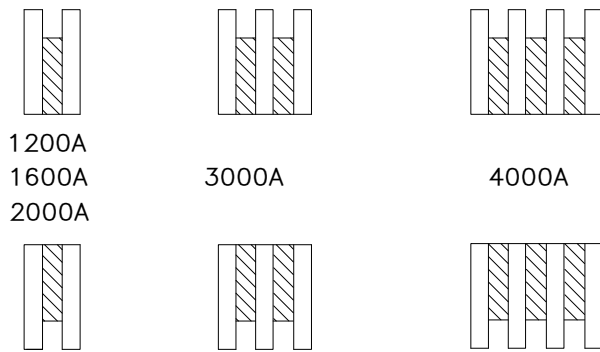

FIGURE 2
CURRENT TRANSFORMER COMPARTMENT
> 800 AMPERES

(THESE DIMENSIONS APPLY TO BOTH 1 AND 3-PHASE CURRENT TRANSFORMER COMPARTMENTS)



DETAIL-A

(ALL BUS DETAILS AND SPACERS ARE 1/4")

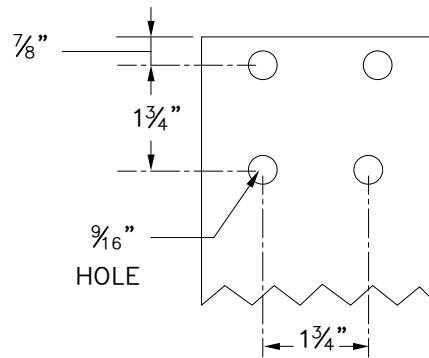

DETAIL-B

This page intentionally left blank

MODULAR CT COMPARTMENT

480V OR LESS

NOTES:

APPLICATION:

- THIS STANDARD DESCRIBES THE REQUIREMENTS FOR THE CONSTRUCTION OF MODULAR CURRENT TRANSFORMER COMPARTMENTS ≤ 800 AMPERES.

INFORMATION:

1. FOR THE INSTALLATION OF ≤ 800 A MODULAR CURRENT TRANSFORMER COMPARTMENT SEE FIGURE 1. CUSTOMER TO FURNISH, INSTALL AND MAINTAIN THE FOLLOWING EQUIPMENT:
 - A – CURRENT TRANSFORMER CABINET. CABINET SHALL COMPLY WITH THE "NATIONAL ELECTRIC CODE" AND BE APPROVED BY THE COMPANY PRIOR TO CONSTRUCTION. TRANSFORMER CABINET SHALL ALSO HAVE A HINGED DOOR WITH SEALING HASP (7/16" HOLE).
 - B – INSULATED MOUNTING BASE, 1" x 4" FASTENER TO MOUNTING BRACKETS.
 - C – MOUNTING BRACKETS FASTENED TO SIDES OR BACK OF CABINET.
 - D – BUS DETAIL DRILLED AND TAPPED FOR TRANSFORMER, LUG AND JUMPER BOLTS, AND #10-24 BUS POTENTIAL TAP SCREWS.
 - E – JUMPER BOLTS – 1/2".
 - F – TWO 1/2" TRANSFORMER MOUNTING BOLTS SPACED ON 1-3/8" CENTERS AT EACH END OF CURRENT TRANSFORMER.
 - G – CENTER POSITION – (NOT REQUIRED IF SERVICE IS SINGLE PHASE, THREE-WIRE. FOR THREE-PHASE, THREE-WIRE SERVICE.) A BUS DETAIL IS REQUIRED WITH PROVISIONS FOR CABLE CONNECTION LUGS AND A #10-24 BUS POTENTIAL TAP SCREW. FOR 3-PHASE, 4-WIRE SERVICE, BUS DETAILS (ITEM "D") AND THE HARDWARE FOR INSTALLATION OF A CURRENT TRANSFORMER ARE REQUIRED.
 - H – BUS DETAIL FOR NEUTRAL PHASE
2. ComEd TO FURNISH, INSTALL AND MAINTAIN, OR ComEd TO FURNISH AND MAINTAIN, CUSTOMER TO INSTALL:
 - J – CURRENT TRANSFORMERS AND WIRING IN ACCORDANCE WITH STANDARD **C9150**.

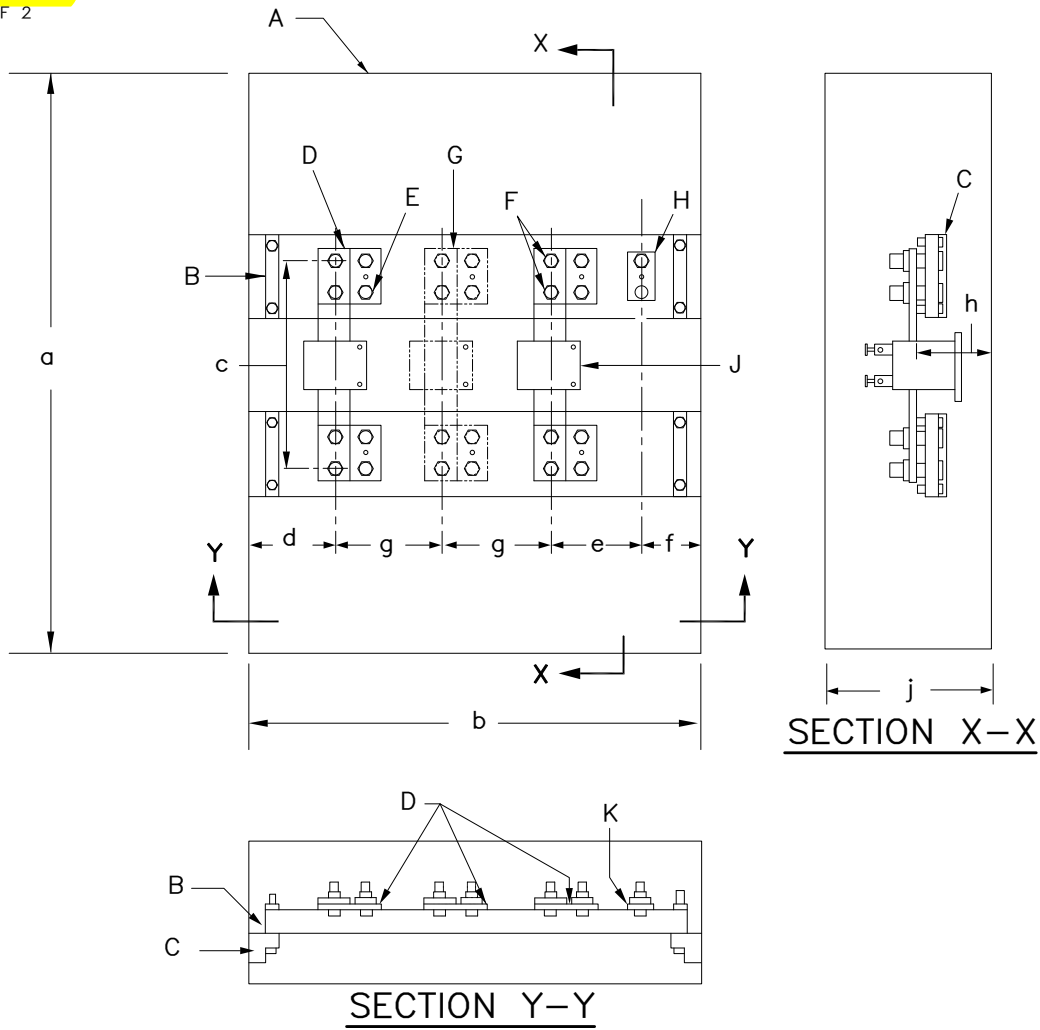

FIGURE 1
MODULAR CURRENT
TRANSFORMER COMPARTMENT
≤800 AMPERES

*MINIMUM DIMENSIONS (INCHES)								
a	b	c	d	e	f	g	h	j
30	24	10 ⁷ / ₈	3 ¹ / ₄	6 ¹ / ₄	2 ¹ / ₂	6	3 ³ / ₄	8

*THESE DIMENSIONS APPLY TO BOTH SINGLE AND 3-PHASE CURRENT TRANSFORMER COMPARTMENTS.

*CURRENT TRANSFORMER COMPARTMENT MAYBE TOP OR BOTTOM FED BY BUS. UPPER AND/OR LOWER PORTIONS OF MODULAR CURRENT TRANSFORMER COMPARTMENT DETAILS ARE NOT SHOWN.

1-PHASE CURRENT TRANSFORMER METERING

120/240V

NOTES:

APPLICATION:

- THIS STANDARD DESCRIBES THE REQUIREMENTS FOR THE INSTALLATION OF A 1-PHASE, 3-WIRE 120/240V CURRENT TRANSFORMER.

INFORMATION:

1. CUSTOMER TO FURNISH, INSTALL AND MAINTAIN THE FOLLOWING EQUIPMENT:
 - A – CURRENT TRANSFORMER CABINET.
 - B – CONDUIT AND CONDUCTORS ON LINE SIDE OF CURRENT TRANSFORMERS.
 - C – CONDUIT AND CONDUCTORS ON LOAD SIDE OF CURRENT TRANSFORMERS.
 - D – ONE-INCH CONDUIT TO ENCLOSE CURRENT AND POTENTIAL CONDUCTORS.
 - E – TRANSFORMER RATED METER CONNECTION DEVICE WHICH SHOULD BE INSTALLED AS CLOSE AS POSSIBLE TO CURRENT TRANSFORMER CABINET. METER CONNECTION DEVICE MAY BE MOUNTED ON DOOR OF CURRENT TRANSFORMER CABINET ONLY IF REQUIRED METER MOUNTING HEIGHTS AND CLEARANCES CAN BE MAINTAINED IN SUCH CASES A FLEXIBLE WIRING HARNESS OF AN APPROVED TYPE MUST BE FURNISHED BY THE MANUFACTURER.
 - F – METER TEST SWITCH TERMINALS FOR CONNECTION OF CURRENT AND POTENTIAL CONDUCTORS.
 - G – CONDUIT AND CONDUCTORS TO CUSTOMER'S AUXILIARY DEMAND DEVICE WHEN REQUIRED.
2. ComEd TO FURNISH AND MAINTAIN THE FOLLOWING EQUIPMENT:
 - H – CURRENT TRANSFORMERS.
 - J – COLOR-CODED CURRENT AND POTENTIAL CONDUCTORS.

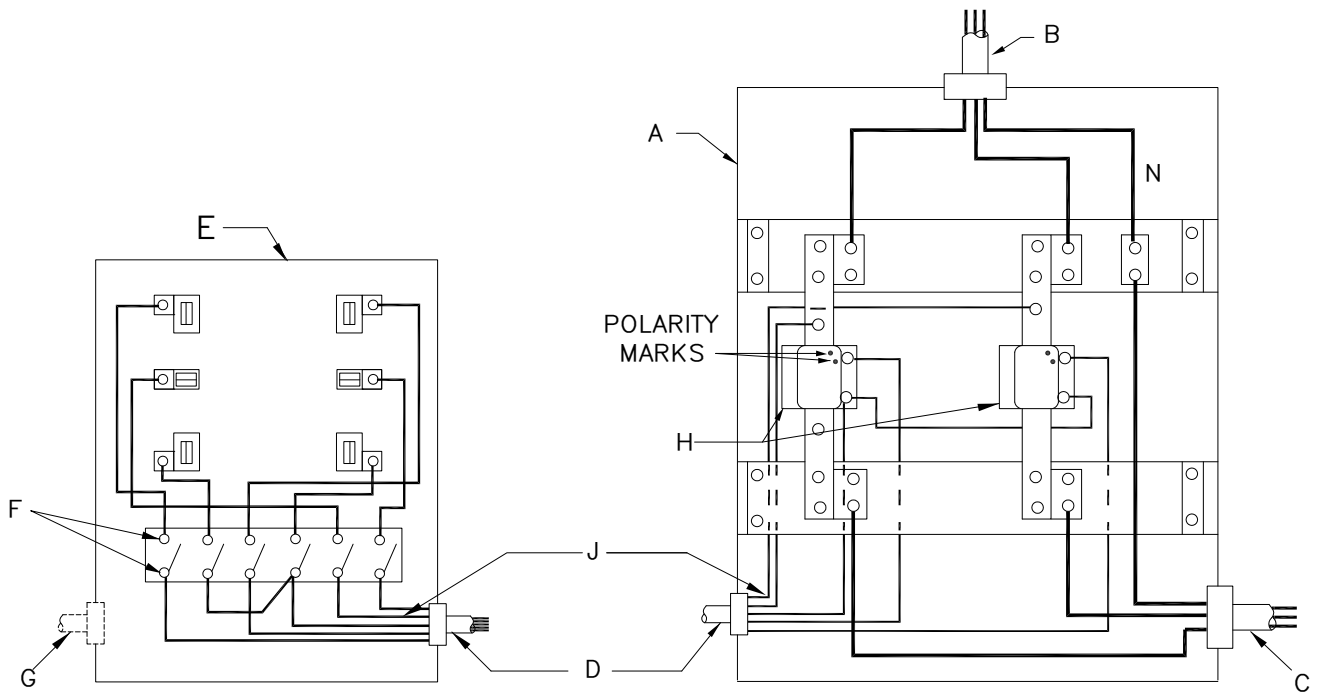

METER CONNECTION DEVICE

CURRENT TRANSFORMER COMPARTMENT

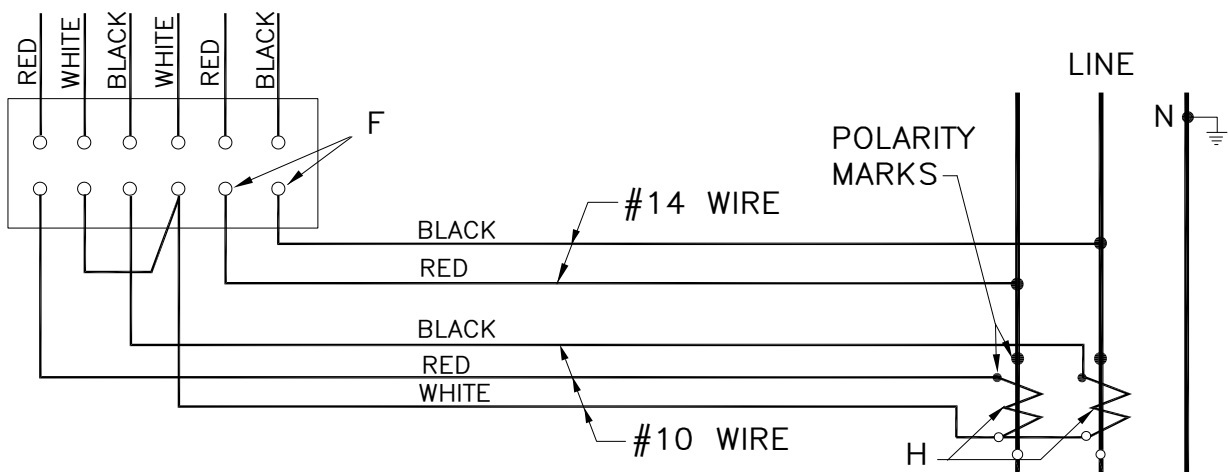

WIRING DIAGRAM

3-PHASE CURRENT TRANSFORMER METERING

480V OR LESS

NOTES:

APPLICATION:

- THIS STANDARD DESCRIBES THE REQUIREMENTS FOR THE INSTALLATION OF: 3-PHASE, 3-WIRE, 480V (FIGURE 1), 3-PHASE, 4-WIRE, DELTA 120/240V (FIGURE 2), 3-PHASE, 4-WIRE, WYE 120/208 OR 277/480V (FIGURE 3) CURRENT TRANSFORMER METERING.

INFORMATION:

1. CUSTOMER TO FURNISH, INSTALL AND MAINTAIN THE FOLLOWING EQUIPMENT AS SPECIFIED IN THE APPROPRIATE FIGURE:
 - A – CURRENT TRANSFORMER COMPARTMENT IN ACCORDANCE WITH STANDARD C9140.
 - B – CONDUIT AND CONDUCTORS ON LINE SIDE OF CURRENT TRANSFORMERS.
 - C – CONDUIT AND CONDUCTORS ON LOAD SIDE OF CURRENT TRANSFORMERS.
 - D – ONE-INCH CONDUIT TO ENCLOSE CURRENT AND POTENTIAL CONDUCTORS.
 - E – TRANSFORMER RATED METER CONNECTION DEVICE WHICH SHOULD BE INSTALLED AS CLOSE AS POSSIBLE TO CURRENT TRANSFORMER CABINET. METER CONNECTION DEVICE MAY BE MOUNTED ON DOOR OF CURRENT TRANSFORMER CABINET ONLY IF REQUIRED METER MOUNTING HEIGHTS AND CLEARANCES CAN BE MAINTAINED. IN SUCH CASES A FLEXIBLE WIRING HARNESS OF AN APPROVED TYPE MUST BE FURNISHED BY THE MANUFACTURER.
 - F – METER TEST SWITCH TERMINALS FOR CONNECTION OF CURRENT AND POTENTIAL CONDUCTORS.
 - G – CONDUIT AND CONDUCTORS TO CUSTOMER'S AUXILIARY DEMAND DEVICE WHEN REQUIRED.
 - H – TERMINAL FOR CONNECTION OF GROUNDED PHASE. IF NO GROUNDED PHASE, THEN ANY PHASE.
 - J – CONDUCTOR FOR HIGH PHASE.
 - ▶ K – CURRENT TRANSFORMERS – ALL ARE FURNISHED AND MAINTAINED BY ComEd. CT'S RATED $\leq 800A$ ARE INSTALLED BY ComEd, CT'S RATED $> 800A$ ARE PROVIDED BY ComEd FOR INSTALLATION BY CUSTOMER.
2. ComEd TO FURNISH, INSTALL AND MAINTAIN THE FOLLOWING EQUIPMENT:
 - ▶ K – CURRENT TRANSFORMERS – ALL ARE FURNISHED AND MAINTAINED BY ComEd. CT'S RATED $\leq 800A$ ARE INSTALLED BY ComEd. CT'S RATED $> 800A$ ARE PROVIDED BY ComEd FOR INSTALLATION BY CUSTOMER.
 - ▶ L – COLOR-CODED CURRENT AND POTENTIAL CONDUCTORS.

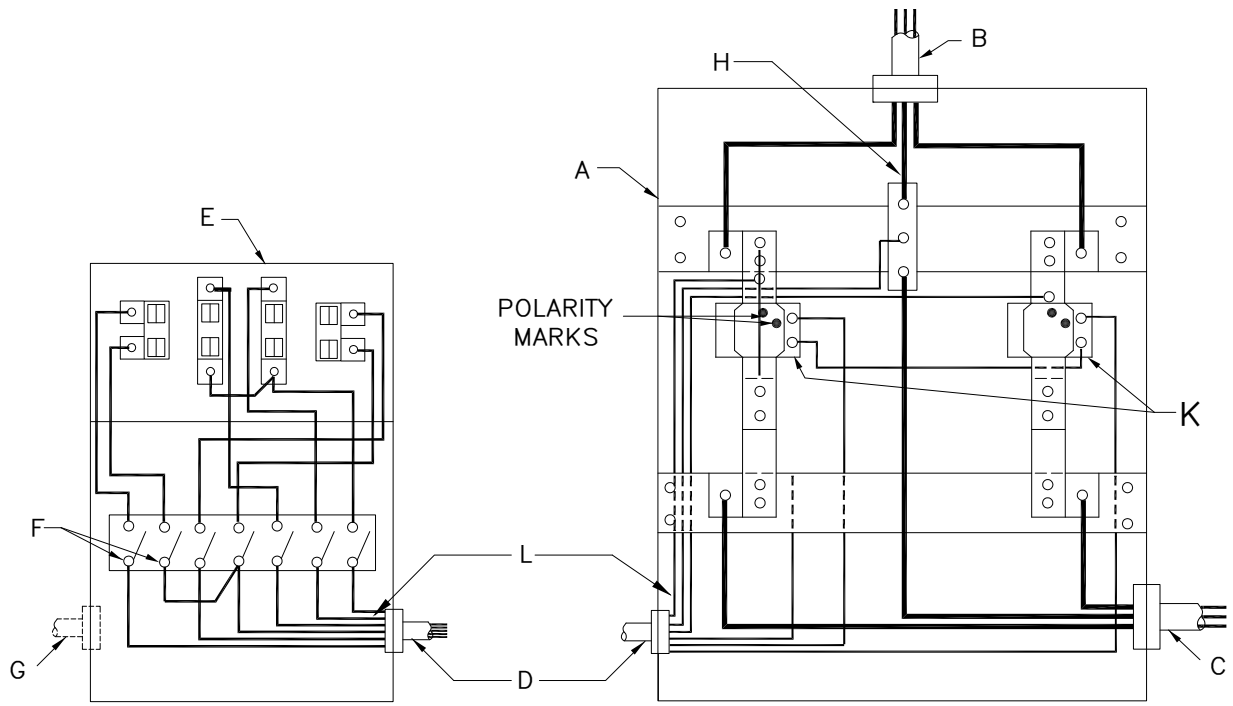

METER CONNECTION DEVICE

CURRENT TRANSFORMER COMPARTMENT

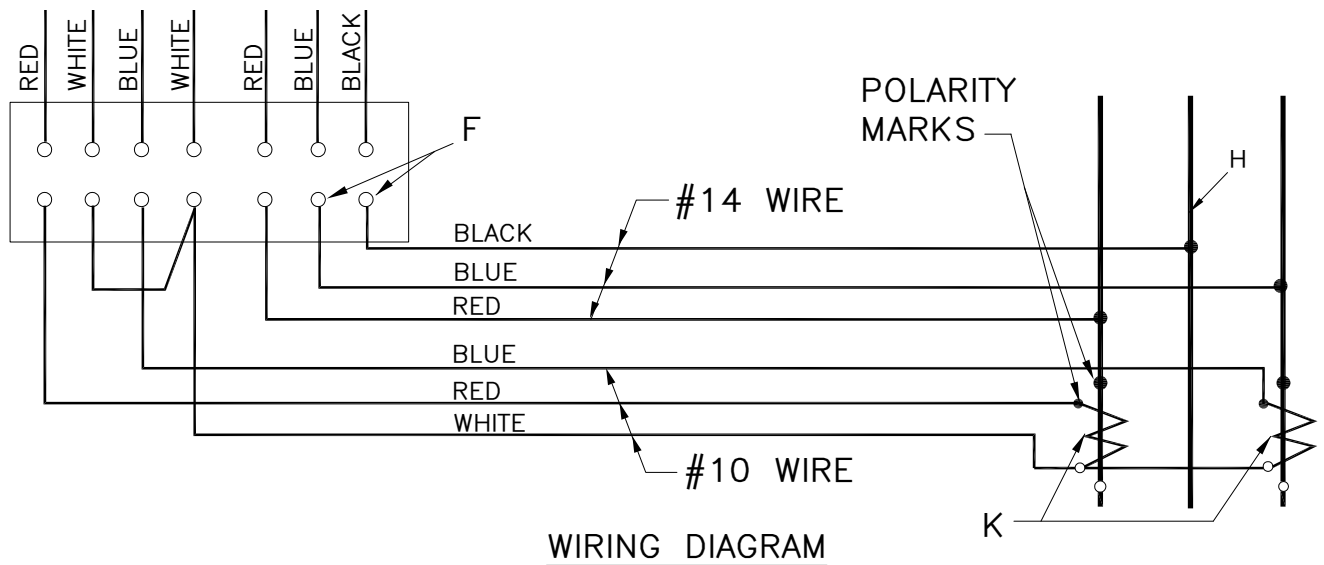

WIRING DIAGRAM

FIGURE 1
3-PHASE, 3-WIRE, 480V

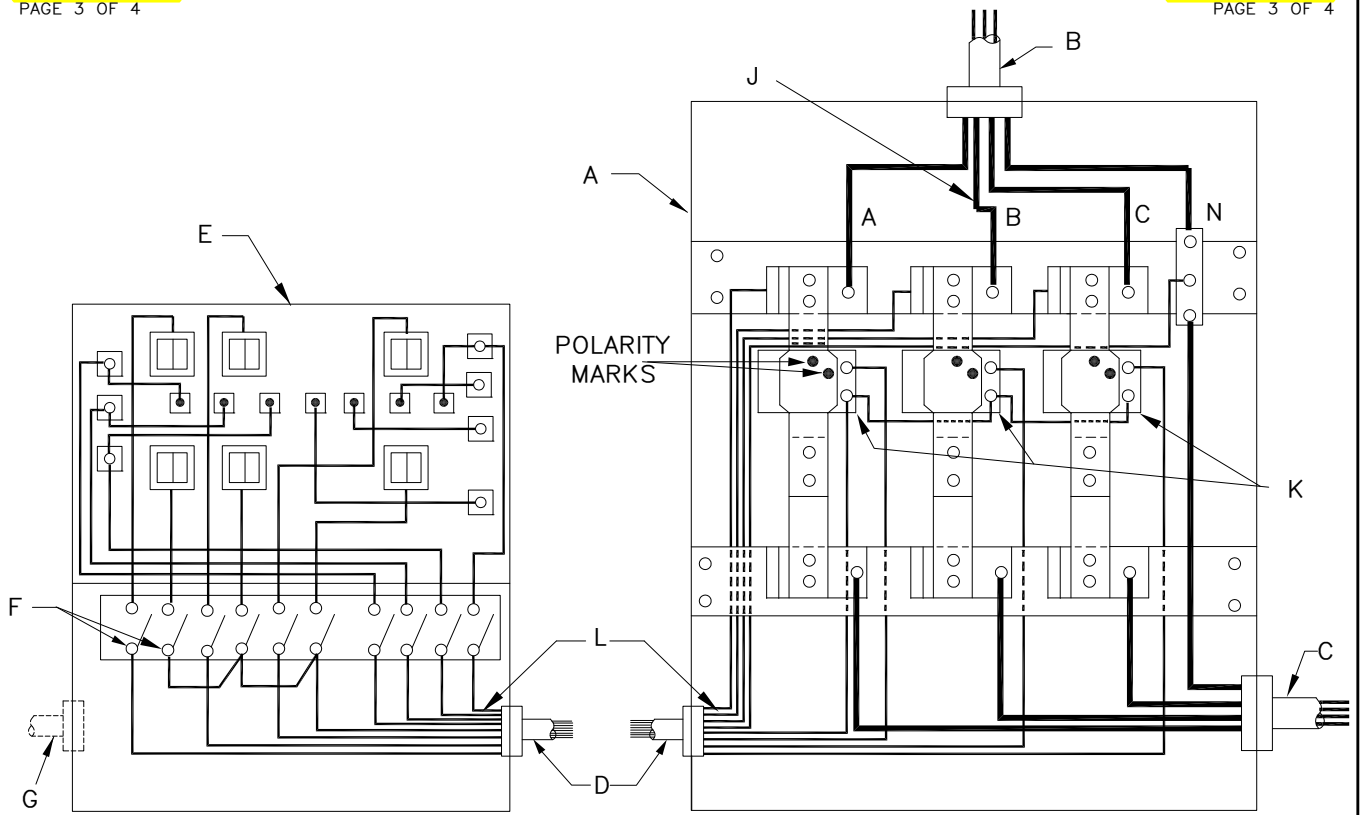

METER CONNECTION DEVICE

CURRENT TRANSFORMER COMPARTMENT

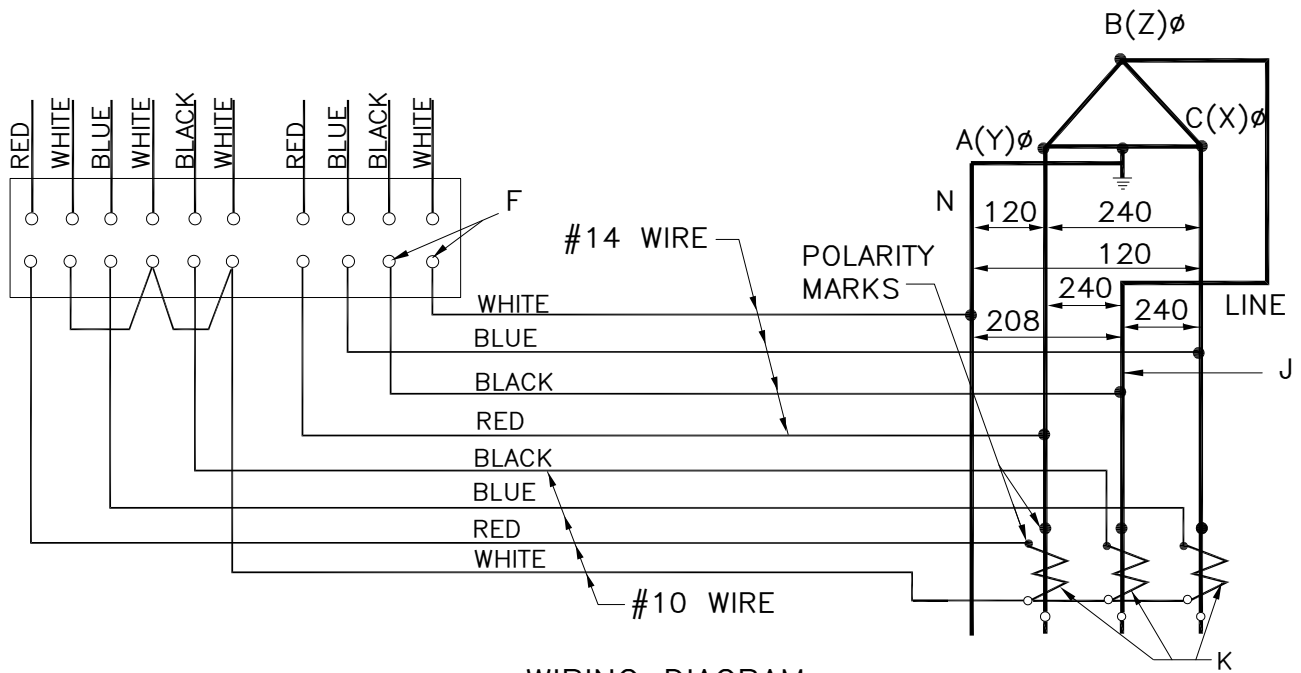

WIRING DIAGRAM

FIGURE 2

3-PHASE, 4-WIRE DELTA 120/240V

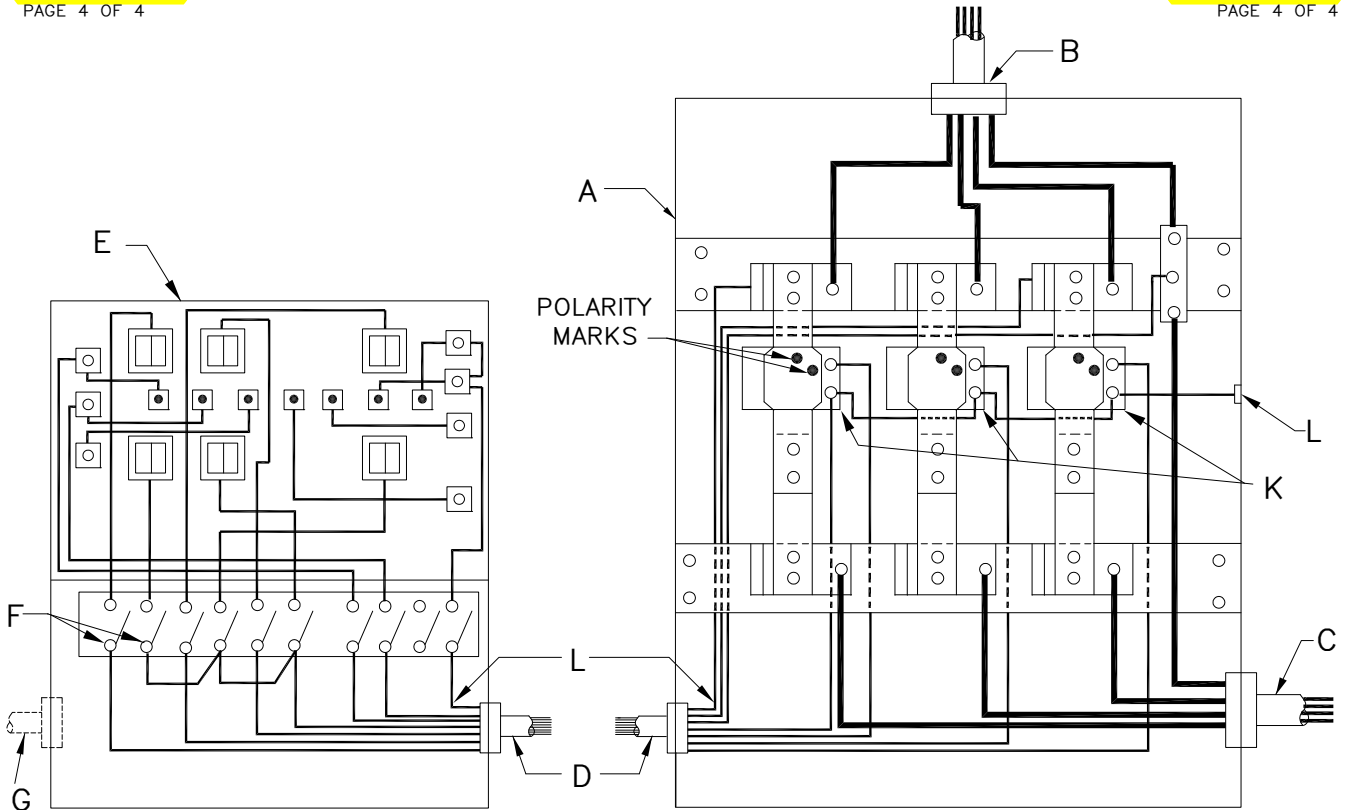

METER CONNECTION DEVICE

CURRENT TRANSFORMER COMPARTMENT

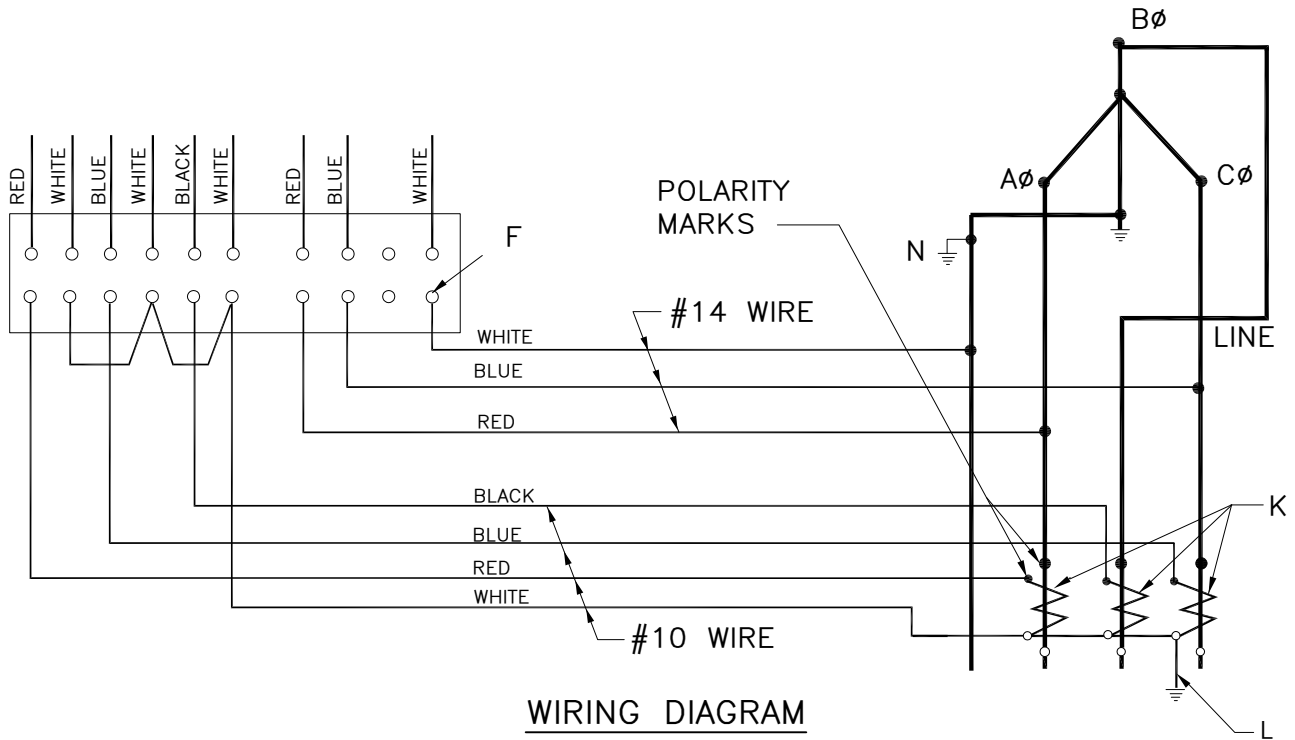

WIRING DIAGRAM

FIGURE 3

3-PHASE, 4-WIRE WYE 120/208 OR 277/480V

APPROVED FOR PUBLIC DISTRIBUTION

SCADA & AMI METERING

NOTES:

APPLICATION:

THIS STANDARD DESCRIBES THE REQUIREMENTS FOR THE INSTALLATION OF SCADA METERING FOR LARGE INDUSTRIAL CUSTOMERS THAT NEED DATA SENT TO PJM OR DATA SENT TO ComEd BULK POWER OPERATIONS.

INFORMATION:

1. CUSTOMER TO FURNISH, INSTALL, OWN AND MAINTAIN THE FOLLOWING EQUIPMENT:
(SEE FIGURES 1 THRU 4)
 - A – CECHA (ComEd CHICAGO HOUSING AUTHORITY) APPROVED METER FITTING (FORM 5S, FORM 6S, OR FORM 9S).
 - B – NEMA 3R DEMARCATION COMMUNICATION BOX (MINIMUM REQUIREMENTS TO BE NO LESS THAN 18" X 18" X 6").
 - C – 2" CONDUIT AND FITTINGS FROM METER FITTING TO DEMARCATION COMMUNICATION BOX.
 - D – 120VAC AUX POWER INSTALLED IN THE DEMARCATION COMMUNICATION BOX.
 - E – STRONG CELLULAR CDMA (VERIZON) COVERAGE (SIGNAL STRENGTH OF -95dBm OR BETTER) MUST BE PRESENT AT METER FITTING.
2. ComEd TO FURNISH, INSTALL, OWN AND MAINTAIN THE FOLLOWING EQUIPMENT:
(SEE FIGURES 1 AND 2)
 - F – SCADA BREAKOUT BLOCK.
 - G – SCADA METER.
 - ▶ H – AMI METER.
 - J – SCADA COMMUNICATION CABLE.
3. CUSTOMER TO CONTACT ComEd's RELAY AND PROTECTION ENGINEERING (T&S) DEPARTMENT FOR EQUIPMENT REQUIREMENTS NECESSARY FOR DATA COLLECTION.
4. REFER TO STANDARD C9110 FOR METER MOUNTING AND FRONTAL, SIDE & SWINGING DOOR CLEARANCES.

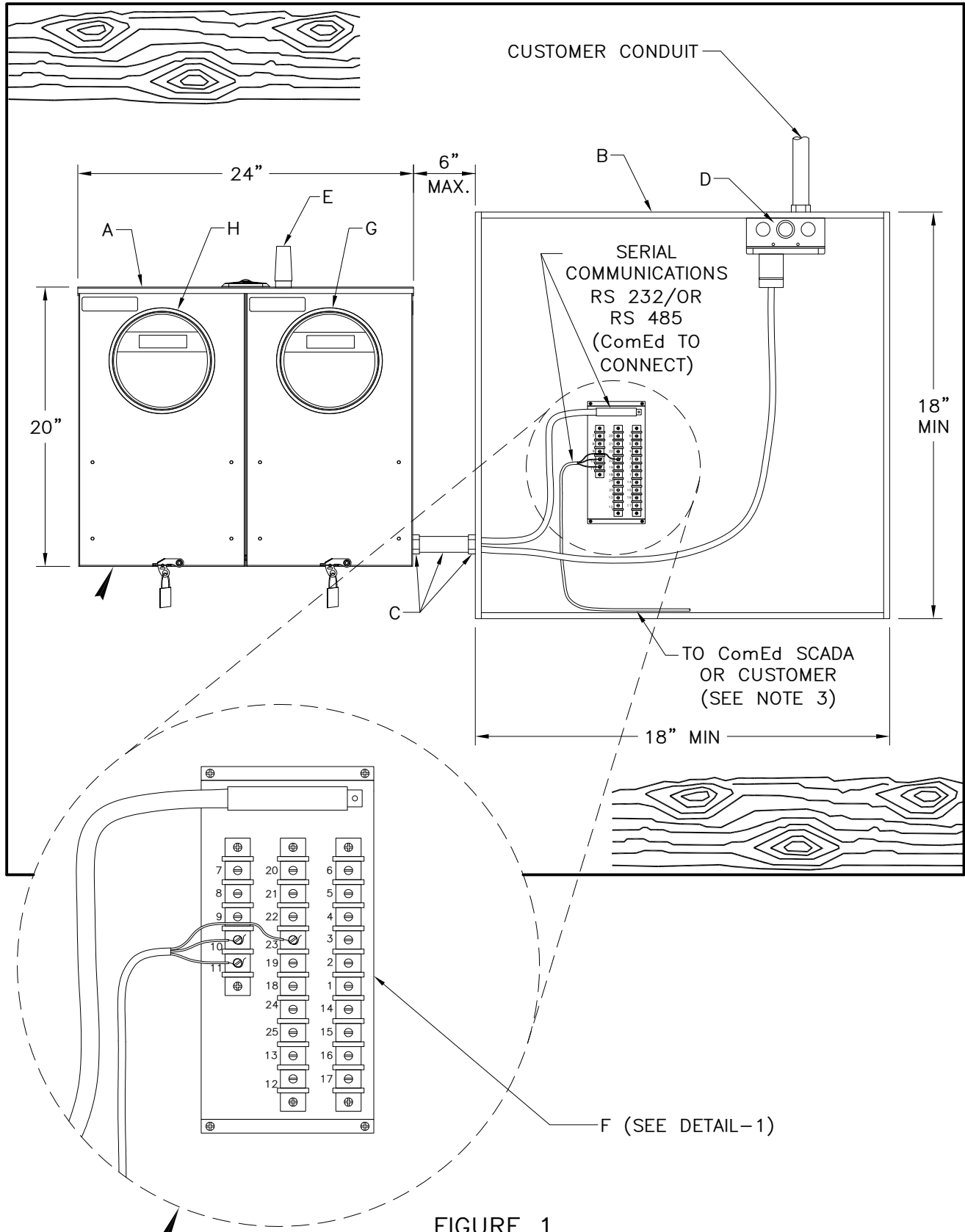

FIGURE 1

AMI METER ADJACENT TO SCADA METER WITH EMBEDDED CELL MODEM & SERIAL COMMUNICATIONS

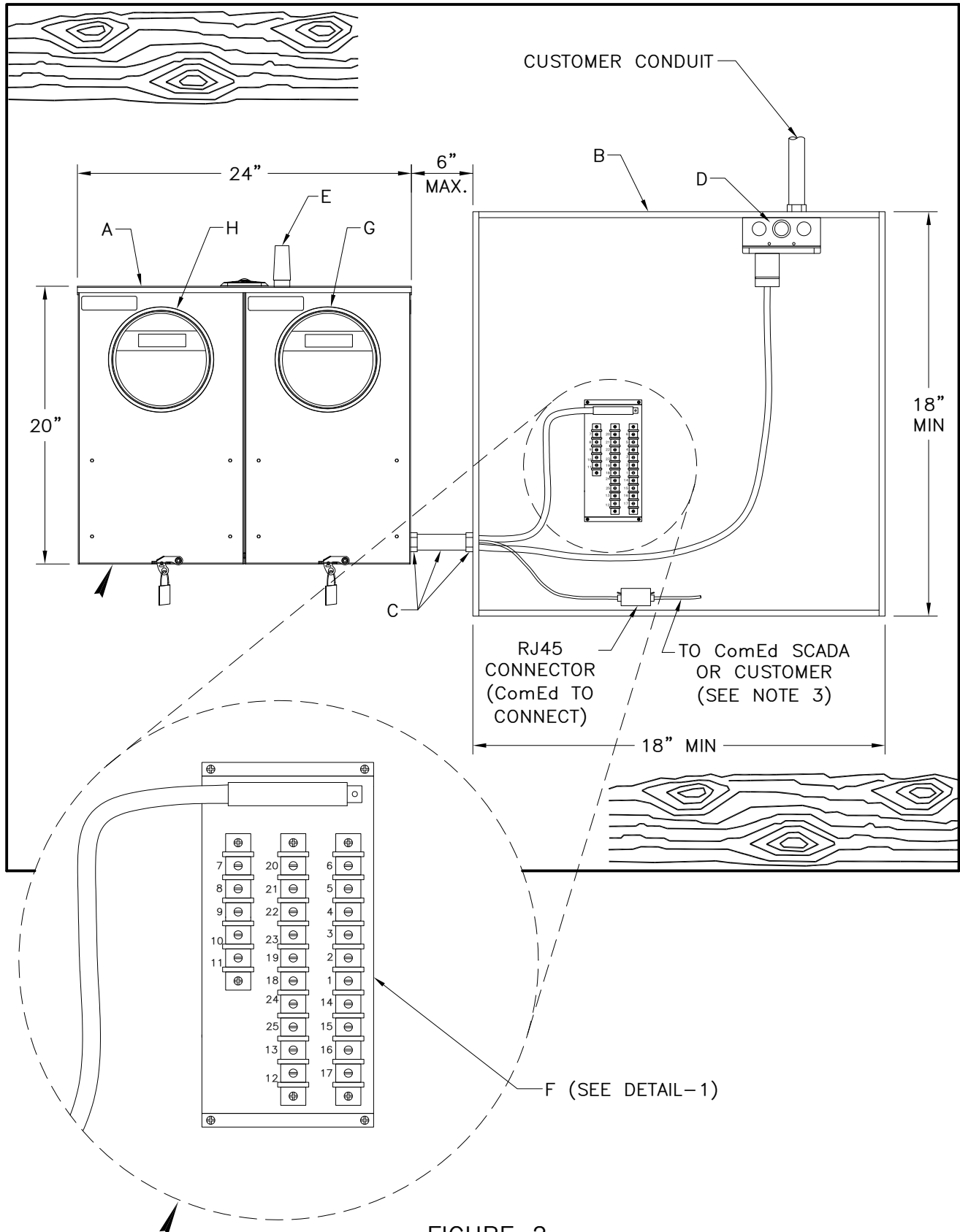
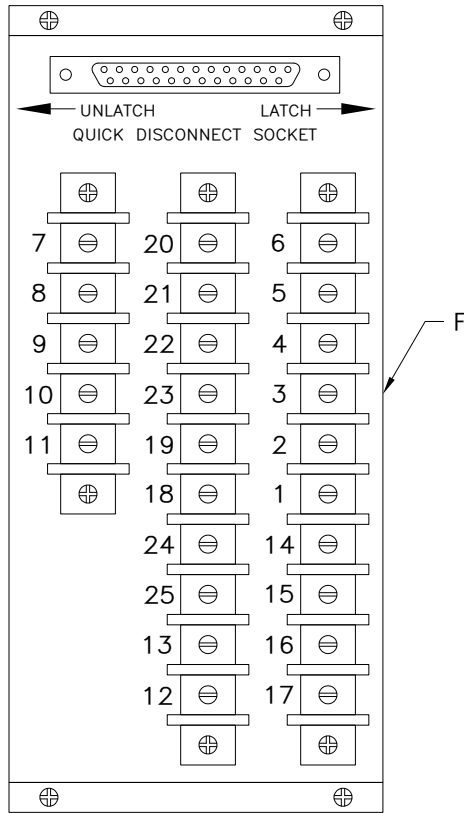

FIGURE 2

AMI METER ADJACENT TO SCADA METER WITH EMBEDDED CELL MODEM & IP ETHERNET



PIN	KYZ OUTPUT	PIN	OUTPUT
1	Y1	24	TIP LINE (T0) FOR MODEM
2	K1 RELAY 1	12	RING LINE (R0) FOR MODEM
14	Z1	13	REGISTER RS232 RX
15	Y2	25	REGISTER RS232 TX
3	K2 RELAY 2	10	SCADA RS232/RS485 RX (B/-)
16	Z2	23	SCADA RS232/RS485 TX (A/+)
17	Y3	11	RS232 GROUND
4	K3 RELAY 3	21	DEM. THRESHOLD / CONTROL OUTPUT #3
18	Z3	9	CAP BANK LAG / CONTROL OUTPUT #4
19	Y4	22	CAP BANK LEAD / CONTROL OUTPUT #5
5	K4 RELAY 4	20	EOI / CONTROL OUTPUT #1
6	Z4	8	HARMONIC ALARM / CONTROL OUTPUT #2
		7	COMMON FOR 21, 9, 22, 20, 8

UTILIZED FOR ComEd SCADA

DETAIL-1
BREAKOUT BLOCK PIN DESIGNATION