

**Howard[®]
Gem[®]**

 **HOWARD[®]**

***Service
and
Repair Manual***

Howard Gem[®] Service Manual



INTRODUCTION

This service manual has been compiled to give HOWARD Dealers and their staff, a sequence of operations to enable the servicing and repair of a HOWARD GEM ROTAVATOR to be carried out quickly and effectively.

Because of our policy of continuous improvement, this manual should always be used in conjunction with the latest service bulletins covering the GEM. These service bulletins are distributed to all HOWARD horticultural dealers when they are first printed, and back issues are available from us on request. HOWARD GEM service bulletins after bulletin H.63, should be kept with this manual, and a note added to the index of each section affected, so that an up to date record of modifications is kept.

At the start of each section, there is a list of ordinary workshop tools that will be required when carrying out the repairs covered by that section. Some 'special tools' may also be required, of which a complete list can be found under 'special tools' section 'A'.

In addition to the special tools and equipment used during some repairs, a hydraulic or hand operated fly press (of the type found in most workshops) will be required when removing and fitting oilseals and bearings.

Before assembly of component parts, remove dirt and grease and, in the case of new parts, remove the special rust inhibitor, otherwise the function of the component may be restricted when in operation. When ordering spare parts, DO NOT confuse the illustration numbers used in this manual with the TRUE part numbers found in the official parts list, form number L.693.

While every effort is made to ensure that the information contained within this manual is correct, any errors which may occur, should be brought to the attention of our Service Department.

INDEX

	<i>SECTION</i>	<i>PAGE</i>
Specifications, torque loadings, special tools.	A	3
Engine removal, clutch, clutch shaft, air cleaner.	B	7
Gearbox, wheels and hubs.	C	19
Controls.	D	37
Main frame, handlebars, shields.	E	45
Rotor, rotor clutch, drive chain, backplate.	F	51
Lubrication, maintenance and fault finding.	G	61

Although this manual refers to machines in current production, reference is made, where possible, to the history of the various assemblies and components.

ILLUSTRATION REFERENCE

The figures in brackets after component names refer to the illustration number of the component, within the diagram specified by that instruction. e.g. (C25-35) is Section 'C' illustration '25' illustrated component 35—Reverse idler gear.

HISTORY OF THE GEM

The HOWARD GEM has been developed over a period of many years. Since its introduction in 1942, there have been five series of GEM, each series being an improved version of its predecessor.

SERIES I

The original GEM was fitted with 'bicycle type' handlebars, but was not equipped with either a differential or a reverse gear. Series I machines were produced from serial number 101 up to machine serial number 4800, and these machines were fitted with the HOWARD B.J. engine.

SERIES II

'Swinging type' handlebars and a differential were introduced at the start of the series II GEM, and later they were equipped with a reverse gear operated by a lift up lever. Series II machines were produced from serial number 4801 up to machine serial number 14784, and these machines were fitted with the original HOWARD B.J. or a J.A.P. 600cc engine.

SERIES III AND IV

Production of series III and IV machines overlapped. The basic machine remained the same for both, only the engines were different.

Series III machines were produced from serial number 14785, and were fitted with either the HOWARD B.J. or a J.A.P. 600cc engine. During production of the series III, the first series IV machines were phased in. These machines were fitted with a new HOWARD engine, the 180° Twin.

From machine serial number 38760 series IV machines only were produced, but were fitted with an improved version of the twin engine—the HOWARD 360° Twin — or alternatively a water cooled Sachs diesel engine. Series IV machines were discontinued at machine serial number 47066.

SERIES V

This is the current series of GEM, which was introduced at machine serial number 47067. Machines up to serial number 2541824 were fitted with an up-rated version of the HOWARD 360° Twin engine, or the Sachs diesel. From machine serial number 2541825, a Kohler K.301T engine has been fitted in place of the twin, or from machine serial number 2571945, an alternative diesel engine, the Hatz ES.780, has been used. An improved version of the Hatz engine has been fitted from machine serial number 250A1021, and is designated the Hatz ES780U.

SUPER GEM

The super GEM is an up-rated version of the Series V model produced specifically for contract work where greater strength and power are required. Super GEM machines are fitted with either a Kohler K341 petrol or Hatz E785 diesel engine.

SPECIFICATIONS

STANDARD GEM

Kohler K301T 4 stroke petrol, producing 11h.p. (max.) at 2800 r.p.m. governed engine speed 22 lb-ft (30Nm) torque at 2200 r.p.m.

SUPER GEM

Kohler K341T 4 stroke petrol, producing 15h.p. (max.) at 2800 r.p.m. governed engine speed 28 lb-ft (38Nm) torque at 2100 r.p.m.

STANDARD GEM

Hatz ES780U stroke diesel producing 9h.p. (max.) at 3000 r.p.m. governed engine speed 19 lb-ft (25.75 Nm) torque at 2100 r.p.m.

SUPER GEM

Hatz E785 4 stroke diesel producing 11h.p. (max.) at 3000 r.p.m. governed engine speed 23 lb-ft (31Nm) torque at 2100 r.p.m.

These engines are air cooled and fitted with an automatic compression release for easy starting.

TRANSMISSION

3-forward gears and one reverse. Full differential with an automatic locking device on engaging the rotor. Rotor safety clutch with a slip action when under shock load.

ENGINE CLUTCH

Single plate, heavy duty, dry friction plate.

CONTROLS

All situated within easy reach of the operator, and are as follows:

1. Clutch lever.
2. Throttle lever.
3. Gear lever with spring out safety device when using reverse gear.
4. Handlebars adjustable for height and side swing.
5. Rotor selector and differential lock control.
6. Depth setting lever.

ROTOR

Rotor speed 188 rpm at an engine speed of 2800 rpm. Rotor widths of 20" (51 cm), 24" (61 cm) and 30" (76 cm). Tillage depth is adjustable down to 9" (23 cm).

WHEELS

20" overall diameter using 4.00 x 12 2-ply pneumatic tyres. Tyre pressure is 20 lb/in² (1.4 kg/cm²).

LANDSPEEDS

At 2800 rpm. engine speed:—

1st gear	— 0.96 mph.	— 1.4 kph
2nd gear	— 1.46 mph.	— 2.3 kph
3rd gear	— 3.05 mph.	— 4.9 kph
Reverse	— 1.85 mph.	— 2.9 kph

The above landspeeds refer to machines built after serial number 250A1021 only. These machines are the current production model, fitted with either the Kohler K.301T/K341T or the Hatz ES.780U/E785 engines and the latest 36/7 ratio crownwheel and pinion. (See the crownwheel and pinion history in section 'B').

Section A - Specifications

WEIGHT

<i>Petrol model</i>	<i>Diesel model</i>
20" – 644 lbs (292 kg)	652 lbs (296 kg)
24" – 672 lbs (305 kg)	674 lbs (306 kg)
30" –	790 lbs (358 kg)
<i>SUPER GEM</i>	
<i>Petrol model</i>	<i>Diesel model</i>
24" – 630 lbs + dead weights	746 lbs (338 kg)
30" –	862 lbs (391 kg)

RECOMMENDED LUBRICANTS

Gearbox and chaincase – SAE 90 gear oil, all others oiling points use – engine oil.

TORQUE LOADINGS

All nuts and bolts must be kept tight, and as a guide the following table of torque loadings may help. In the absence of a suitable torque wrench, spanners of the length specified in the right hand column of the table below, will, if used to maximum effect by the average man, give comparable loadings.

<i>Thread size</i>	<i>Torque loading</i>		<i>Spanner length</i>	
	<i>lbs/ft</i>	<i>kg/m</i>	<i>inches</i>	<i>cms</i>
$\frac{1}{4}$ " BSW	8.5	1.2	5	12.5
$\frac{5}{16}$ " BSW	17.5	2.4	6	15
$\frac{3}{8}$ " BSW & UNC	31	4.2	7	17.5
$\frac{7}{16}$ " BSW & UNC	49.6	6.8	8	20
$\frac{1}{2}$ " BSW & UNC	73.2	10	10	25
$\frac{5}{8}$ " BSW	131.9	18.1	18	45
$\frac{1}{4}$ " BSF	9.5	1.3	5	12.5
$\frac{5}{16}$ " BSF	19	2.6	6	15
$\frac{7}{16}$ " BSF	54.7	7.5	8	20
$\frac{1}{2}$ " BSF	81.2	11.1	10	25
$\frac{5}{8}$ " BSF	163	22.3	18	45
$\frac{3}{4}$ " BSF	283	38.8	36	91.5
Blade bolt and nut	90.2	12.4	12	30

SPECIAL EQUIPMENT

HERMATITE

– is a sealing compound used, where specified, to prevent the possibility of oil leaks.

Manufactured by:-
Kenilworth Manufacturing Co. Ltd.
Hermitite Works,
West Drayton,
Middlesex,
ENGLAND.

SAMPSON C. 110 GLUE

– is an Amyl Acetate glue used, where specified, to secure the fibre discs to the rotor clutch drive discs.

Manufactured by:-
Samuel Jones & Co. Ltd.,
Sampson Adhesive Mill,
St. Neots,
Huntingdonshire,
ENGLAND'

Section A - Special Tools

SPECIAL TOOLS

The following special tools will be required when carrying out certain repairs, and as they are simple in design, can be easily produced from the following dimensioned drawings.

SPECIAL TOOL S.1:—

is a clutch shaft puller used, as specified in instruction '3a' Section 'B', to remove a broken clutch shaft.

SPECIAL TOOL S.2:—

is a hub puller used, as specified in instruction '2' Section 'C', to remove the wheel hubs.

SPECIAL TOOL S.3:—

is a pegged tool used, as specified in Section 'C'. 'To dismantle the axle assembly', to remove the loose hub gear bearing.

SPECIAL TOOL S.4:—

is an axle shaft puller used, as specified in Section 'F' Rotor stub axle-to remove', to remove the broken stub axle.

SPECIAL TOOL S.5:—

is a pegged tool used, as specified in Section 'F' Rotor drive shaft – to remove', to remove the rotor drive shaft sprocket bearing.

SPECIAL TOOL S.6:—

is a pegged tool used, as specified in instruction '8g' Section 'C' to remove the bearing from the gearbox jackshaft.

SPECIAL TOOL S.7:—

is a pointer used in conjunction with $2\frac{3}{8}$ " BSW nuts, as specified in instruction '5b' Section 'B', to enable the crownwheel to pinion backlash to be assessed.

Section A - Special Tools

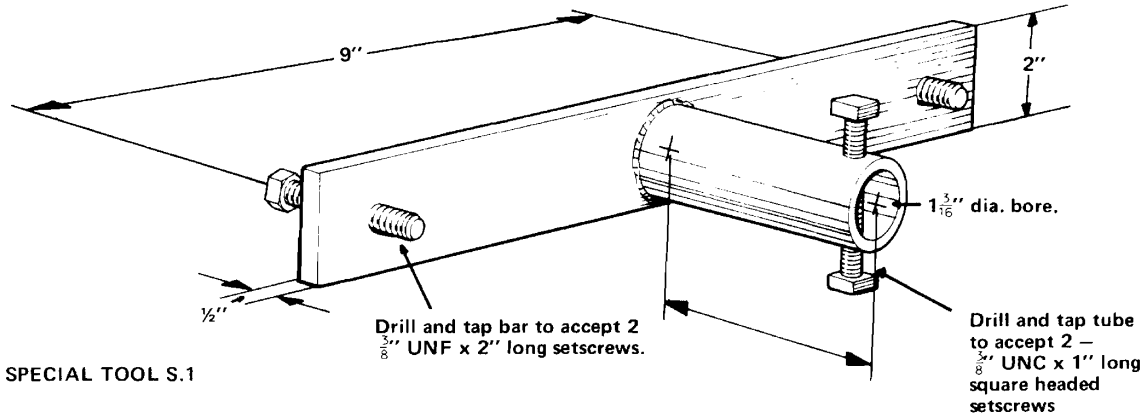

SPECIAL TOOL S.1

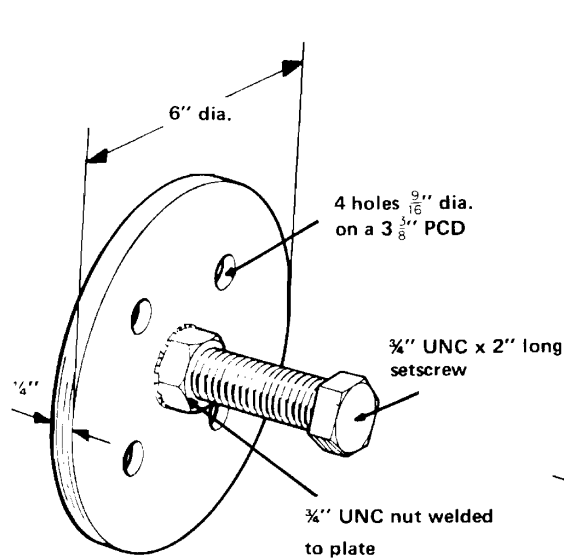

SPECIAL TOOL S.2

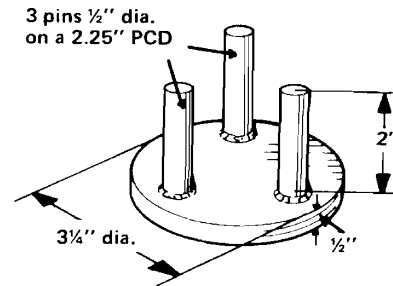

SPECIAL TOOL S.3

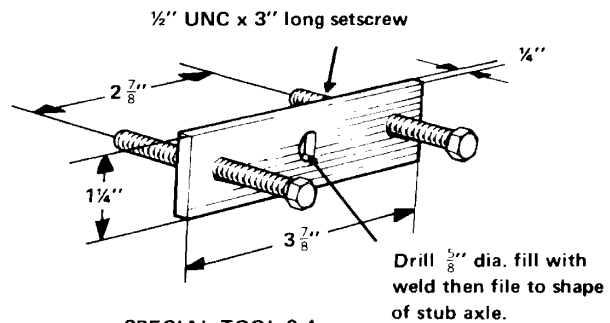

SPECIAL TOOL S.4

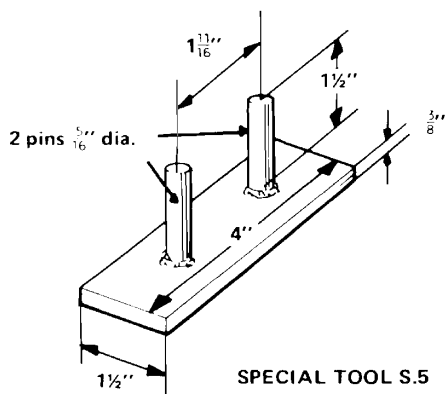

SPECIAL TOOL S.5

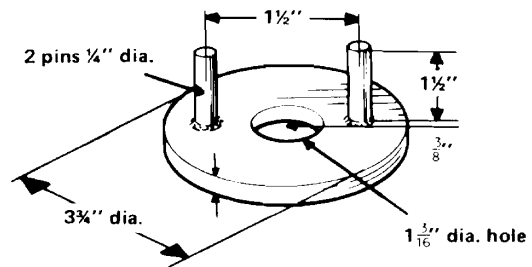

SPECIAL TOOL S.6

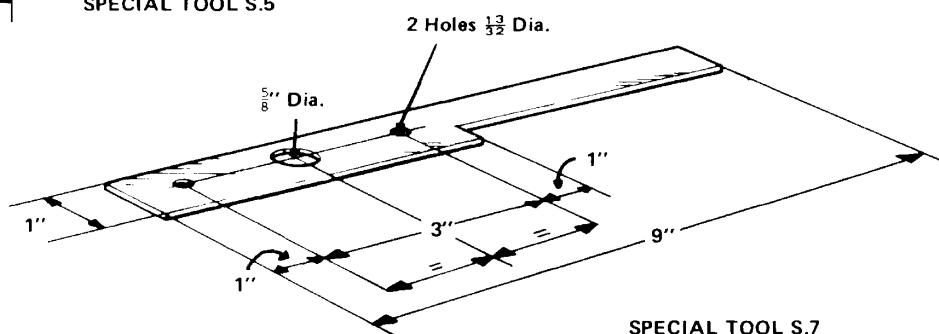

SPECIAL TOOL S.7

CONTENTS

<i>Subject</i>	<i>Action</i>	<i>Page</i>
ADJUSTMENTS		18
BELL HOUSING	Fitting-Hatz	11
	-Kohler	10
	Removal-Hatz	11
	-Kohler	10
CLUTCH SHAFT AND PINION HISTORY		8
CLUTCH SHAFT	Fitting	16
	Removal	13
CLUTCH SHAFT BEARING	Fitting	15
	Removal	15
DRIVE ADAPTOR	Fitting-Hatz	11
	-Kohler	10
	Removal-Hatz	11
	-Kohler	9
ENGINE-HATZ	Description	8
	Fitting	17
	Removal	10
KOHLER	Description	8
	Fitting	17
	Removal	9
ENGINE CLUTCH	Assemble	13
	Dismantle	12
	Fitting	16
	Removal	11

SERVICE BULLETINS APPERTAINING TO THIS SECTION ARE:—

<i>Bulletin No.</i>	<i>Date</i>

TOOLS LIST

<i>No. off</i>	<i>No. off</i>
1 Small (electrical) screwdriver	1 Small punch
1 Large screwdriver	1 Copper/Rawhide mallet
1 ¼" BSW Open ended spanner	1 Pair 6" engineers pliers
1 ¼" BSW Box spanner	1 Pair right angled internal circlip pliers
1 5/16" BSW Open ended spanner	1 Pair straight internal circlip pliers
1 3/8" BSW Ring spanner	
1 7/16" BSW Ring spanner	
1 9/16" AF Ring spanner	
1 5/8" AF Box spanner	
1 11/16" AF Open ended spanner	
1 15/16" AF Ring spanner	
1 5/16" Sq. Extended box spanner	
1 12mm Open ended spanner	
1 13mm Open ended spanner	

SPECIAL EQUIPMENT

Hermatite
 Steel rule
 Container/tray of at least 6 pints capacity

SPECIAL TOOLS

Special tool S.1
 Special tool S.7 and 2-3/8" BSW Nuts

Section B

HISTORY ENGINES

The Kohler K.301T has been fitted from machine serial number 2541825 and is a 477cc 4-stroke petrol engine of 10hp.

From machine serial number 2571945, the Hatz ES.780 diesel engine has been available as an alternative to the Kohler engine. The Hatz is a 500cc 4-stroke diesel engine of 10 hp. An improved version of the Hatz engine, having an antivibration front cover and designated ES.780U, has been fitted from machine serial number 250A1021.

ENGINE CLUTCH

All Kohler and Hatz engined machines are now fitted with a single plate clutch. Machines prior to serial number 2571414, were fitted with a double plate clutch, and the following parts are required if converting the clutch assembly to the single plate version.

<i>Part number</i>	<i>Part description</i>	<i>No. Off</i>
288	Thrust sleeve	1
255	Distance piece	4
250	Special bolt	4

The clutch assembly should be rebuilt substituting these parts for the existing components, and one fibre disc and one loose plate should be discarded from the original assembly. A new clutch shaft – part number 25009 – will also be required.

CLUTCH SHAFT/CROWNWHEEL AND PINION

The crown wheel and pinion were changed on GEM 24" models – machine serial numbers 2592305 and 2306; GEM 30" models – machine serial numbers 2591063, 1067, 1069, 1070, 1138, 1139, 1189, 1190, 1191, 1394 and 1451, and all GEM V models from machine serial number 250A1021.

The ratio of the gears was changed from 36/9 to 36/7 in order to reduce the forward travel speed of the machine, and thus increase its performance. The later ratio gears can be supplied and fitted to machines prior to machine serial number 250A1021, but as a pair only, as the new and the old bevel gears are not interchangeable and must be used with their respective pinions.

New parts

Part number 27367 Bevel gear
Part number 27368 Clutch shaft

Old parts

Part number 25008 Bevel gear
Part number 25009 Clutch shaft
Part number 25007 Pinion
Part number 25061 Special nut
Part number 208010160 Split pin.

NOTE

The new 7-tooth pinion is an integral part of clutch shaft – part number 27368 – and this shaft can only be used with the single plate clutch assembly.

When fitting the new bevel gear – part number 27367 – to the gearbox jackshaft $6\frac{5}{16}$ " dia. x $\frac{7}{8}$ " long rivets (part number 208023040) will be required in place of the original $\frac{5}{16}$ " dia. x $\frac{3}{4}$ " long rivets, which are too short to secure the new bevel gear.

TO REMOVE THE KOHLER ENGINE

1. Refer to illustration "B1" unless otherwise stated.

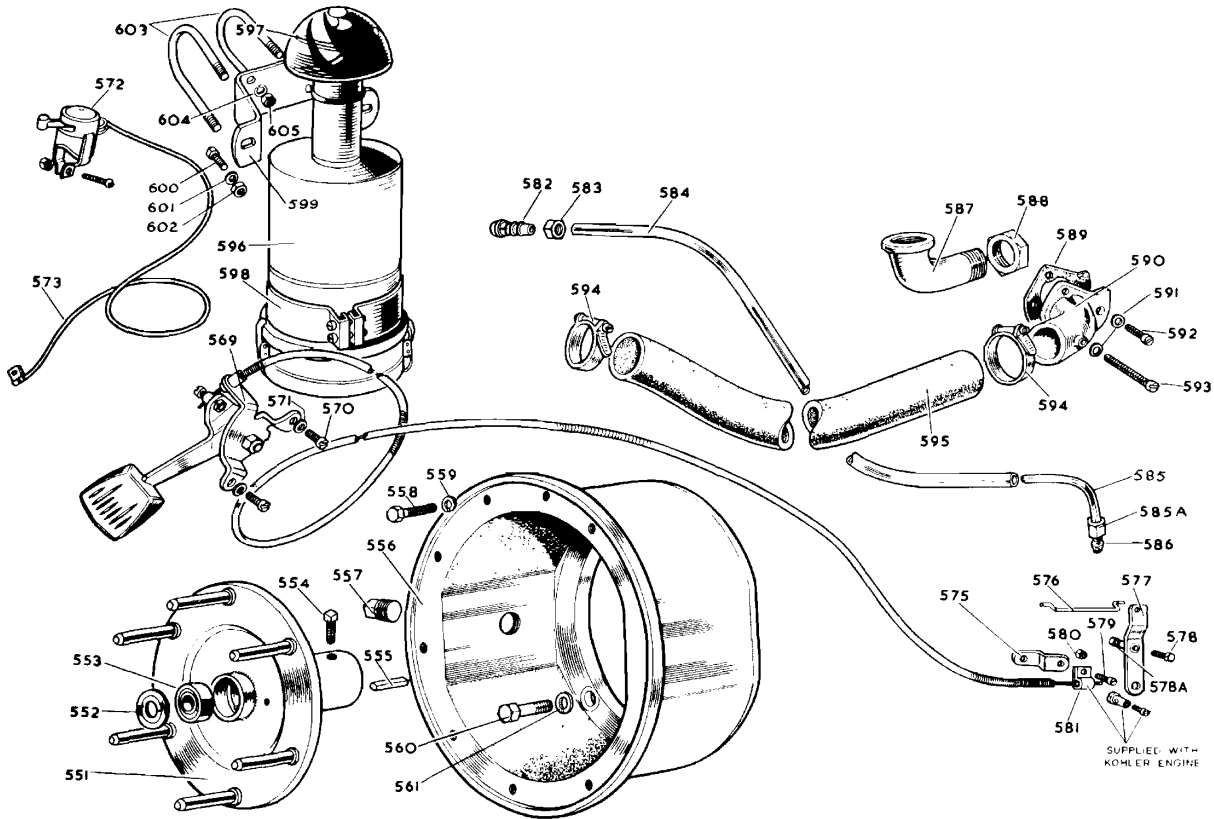

- 1a. Disconnect the throttle control (569) from the engine by releasing the small clamp bolt and cable clamp on the side of the engine.
- 1b. Slacken the jubilee clip on the carburettor induction elbow end of the air cleaner hose (595), and remove the hose from the elbow.
- 1c. Disconnect the stop switch cable (573) from the engine mounted condenser.
- 1d. Turn off the fuel supply from the petrol tank at the fuel filter bowl, and disconnect the pipe from the tank. Drain off any fuel in the pipe before removing from the engine.
- 1e. With the engine suitably supported (on blocks etc.), remove the 8-setscrews (558) from around the perimeter of the clutch bell housing (556). The machine may then be moved clear of the engine.

TO FIT THE ENGINE – See instruction 6.

TO REMOVE THE DRIVE ADAPTOR (551) – KOHLER ENGINE

To remove the drive adaptor from the engine crankshaft, remove the square plug (557) from the side of the bell housing (556), and loosen the square headed setscrew (554) using an extended $\frac{5}{16}$ " square box spanner through the hole in the side of the housing. Slide the adaptor from the housing, and retain the locating key (555) (and spacer if fitted).

If the drive adaptor bearing (553) is to be renewed, the old bearing may be pressed out from the back of the adaptor, with the aid of a 1" dia. drift. The new bearing can then be pressed into its location, greased, and secured by positioning the special washer (552) over the bearing (domed side outermost), and with the aid of a small punch, burr the lip of the bearing housing over the washer in 3 or 4 places.

Section B

TO REMOVE THE BELL HOUSING (556) – KOHLER ENGINE

Having removed the drive adaptor as previously described, remove the 4-setscrews (560) and spring washers (561) from inside the bell housing, thus allowing the bell housing to be removed from the engine.

TO FIT THE BELL HOUSING (556) – KOHLER ENGINE

Position the bell housing against the engine crankcase (with the plug hole to the left), and secure using the 4-setscrews (560) and spring washers (561), located inside the housing.

TO FIT THE DRIVE ADAPTOR (551) – KOHLER ENGINE

With the clutch bell housing in position, slide the spacer (when fitted) onto the engine crankshaft and up to the engine casing.

Position the locating key (555) in the slot in the engine crankshaft, and slide the drive adaptor into position.

Using an extended $\frac{5}{16}$ " square box spanner through the hole in the side of the bell housing, tighten the square headed setscrew which secures the drive adaptor to the engine crankshaft. Replace the plug in the side of the bell housing.

TO REMOVE THE HATZ ENGINE

1. Refer to illustration "B2" unless otherwise stated.
- 1a. Disconnect the large fuel pipe from the injection pump on the engine.

NOTE

Once this fuel line is disconnected, the fuel in the tank will drain out due to gravity, and suitable precautions should be taken.

ILLUSTRATION "B2"

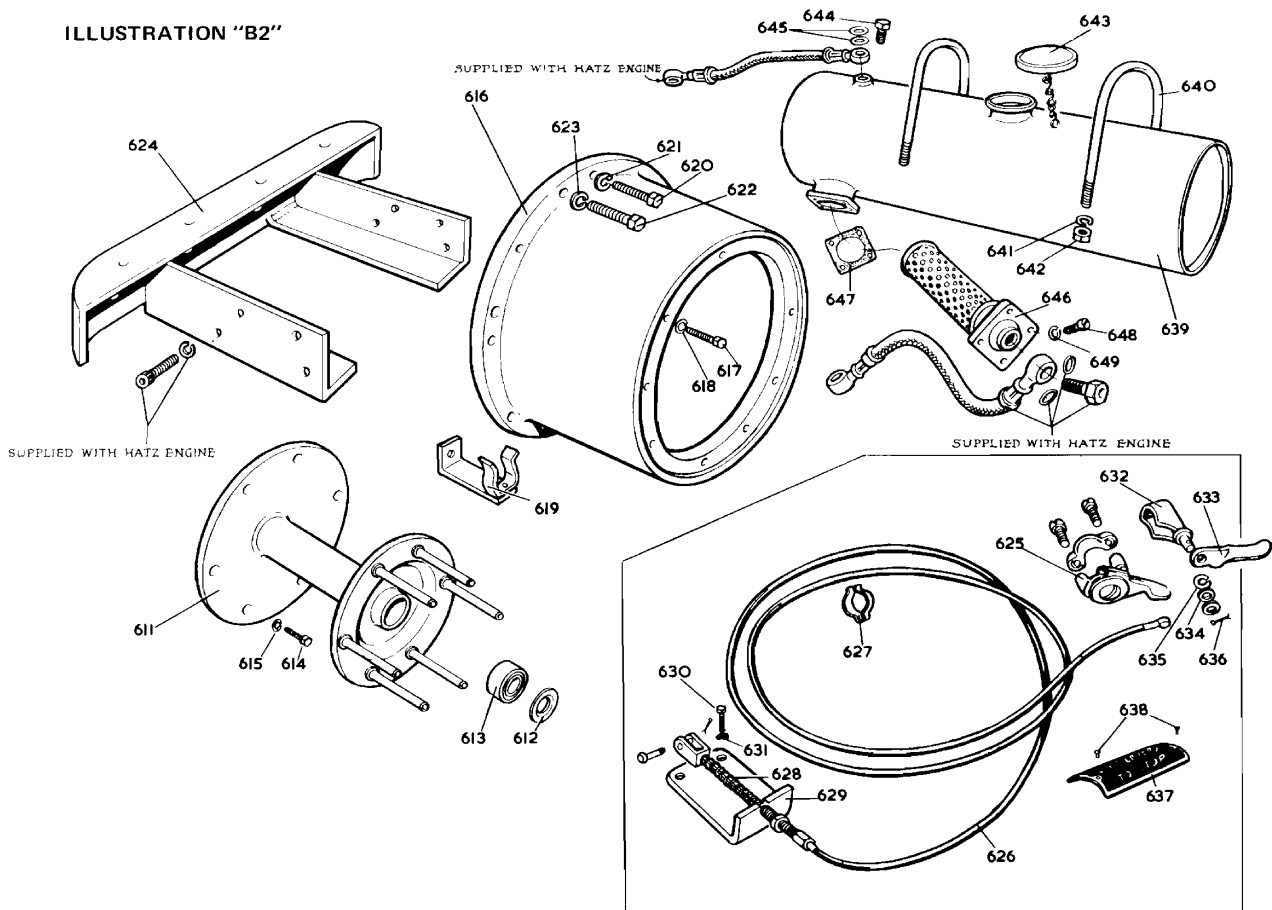

- 1b. Disconnect the small injector spill pipe from the engine.
- 1c. Disconnect the throttle cable clevis (626) from the engine, and having removed the 2-bolts (630) from the throttle bracket (629), move the cable assembly aside.
- 1d. Release the engine starting handle from the spring clip (619) and withdraw the handle from the main frame tube.
- 1e. With the engine suitably supported (on blocks etc.), remove the 8-setscrews (617) which secure the bell housing to the gearbox flange, and retain the spring clip (619).
The machine may then be moved clear of the engine.

TO FIT THE ENGINE - See instruction 6.

TO REMOVE THE BELL HOUSING (616) – HATZ ENGINE

Remove the 10 setscrews (620) and 2-bolts (622) which secure the bell housing to the engine, and hence remove the housing.

TO REMOVE THE DRIVE ADAPTOR (611) – HATZ ENGINE

Remove the bell housing as previously described, then remove the 6-setscrews (614) and spring washers (615) which secure the drive adaptor to the engine. If the drive adaptor bearing (613) is to be renewed, the old bearing may be pressed out from the back of the adaptor, with the aid of a 1" dia. drift. The new bearing can then be pressed into its location, greased, and secured by positioning the special washer (612) over the bearing (domed side outermost), and with the aid of a small punch, burr the lip of the bearing housing over the washer in 3 or 4 places.

TO FIT THE DRIVE ADAPTOR (611) – HATZ ENGINE

Place the drive adaptor against the engine flywheel, and secure in position using the 6-setscrews (614) and spring washers (615).

TO FIT THE BELL HOUSING (616) – HATZ ENGINE

With the drive adaptor in position, locate the bell housing against the engine so that the 2-bolts (622) are positioned at the top. Secure the bell housing using these 2-bolts (622) and the 10-setscrews (620).

TO REMOVE THE ENGINE CLUTCH

2. Remove the engine as described in instruction "1" then proceed as follows :
- 2a. Remove the split pin from the end of the clutch shaft, and while restraining the clutch using a flat bladed screwdriver, as shown in illustration "B3", remove the special nut from the end of the clutch shaft.

Illustration 'B.3'

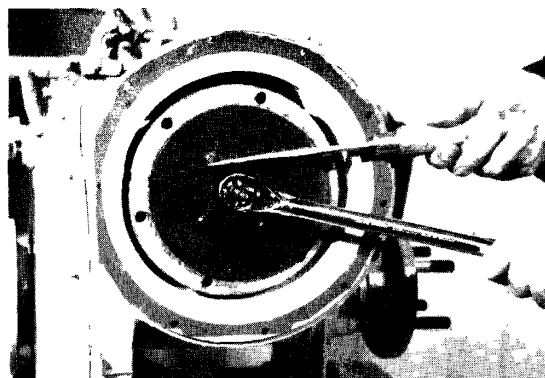

Section B

- 2b. Remove the spacer (fitted to double plate clutches only), and hence remove the clutch plate assembly by holding the clutch operating arm back in the "disengaged position", and using a soft headed hammer, tap the end of the shaft. This will release the clutch assembly from the splines on the clutch shaft.

TO DISMANTLE THE CLUTCH UNIT (Refer to illustration "B4" unless otherwise stated).

If possible, mount the clutch unit on an old drive adaptor, which should be clamped upright in a vice as shown in illustration "B5", as it will make dismantling easier.

Illustration 'B4'

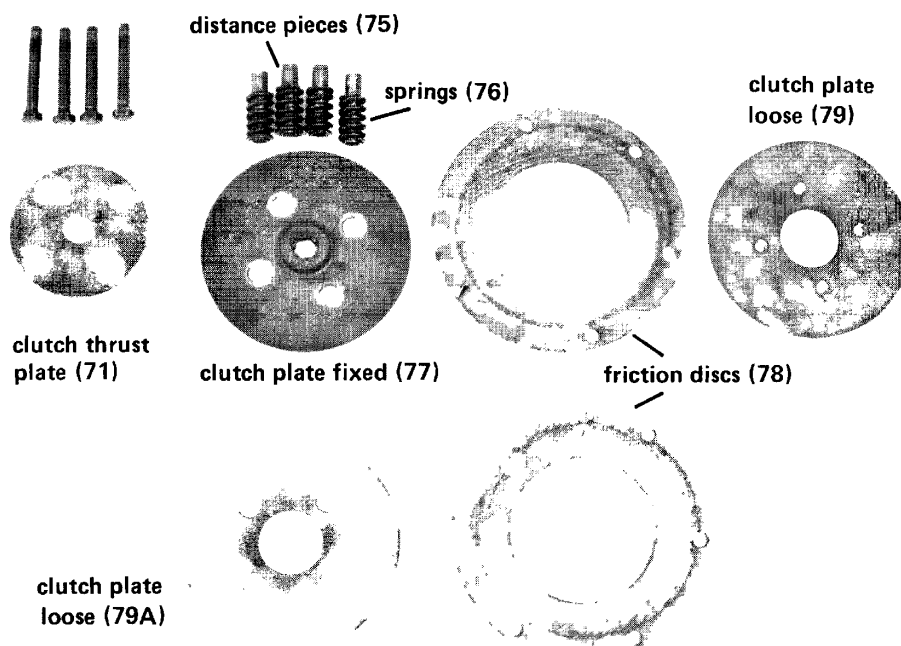
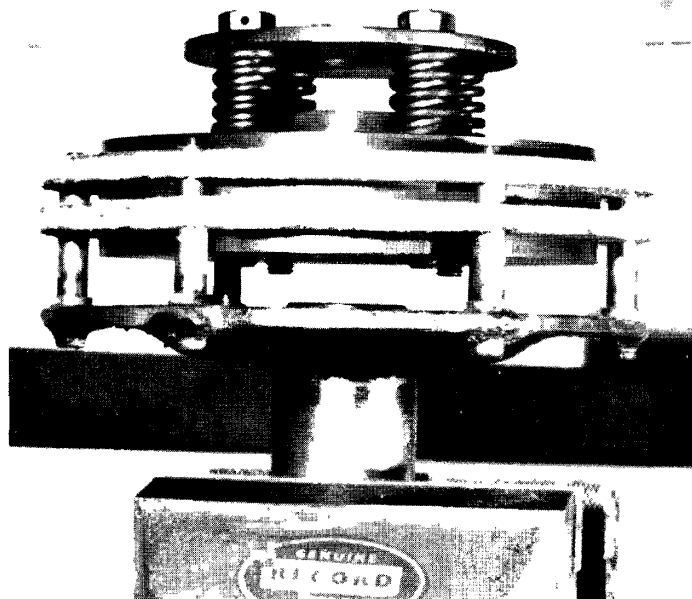

Illustration 'B.5'



Remove the locking wire from the 4 special bolts (73); and so remove these bolts.

The individual components may now be removed in the following order: Clutch thrust plate (71), distance pieces (75) and springs (76), clutch plate fixed (77), disc (78) 2-friction discs and 1-loose plate (79A) (if of the double plate version), and lastly the bottom loose plate (79).

TO ASSEMBLE THE CLUTCH UNIT (refer to illustration "B.4" unless otherwise stated)

Assembly of the clutch unit is the reverse of the dismantling procedure.

When fitting the friction disc(s), check that the plates are central. Fit the 4 special bolts (73) and tighten evenly to a torque of 31 lbs/ft. (4.2 kg/m). Secure the special bolts using a new piece of 12" long 16 swg locking wire.

TO FIT THE CLUTCH UNIT – See instruction 5.

TO REMOVE THE CLUTCH SHAFT

Special note: It is not necessary to dismantle the gearbox in order to remove the clutch shaft or the driving pinion, provided the shaft is not broken inside the gearbox. In cases where the shaft is broken at a point behind the thread, a clutch shaft puller, special tool S.1 (see section A), will be required.

Alternatively it may be possible to weld a stud onto the front of the shaft, so that the same method of removal may be used as for an unbroken shaft, and this method of removal is described below. Should the clutch shaft be broken within the gearbox, see section "C" instruction "7" for an alternative method of removal.

3. Remove the engine and engine clutch as previously described in instruction "1" and "2", then proceed as follows:
 - 3a. Drain the oil from the gearbox (a container of at least 6 pints capacity will be required).
 - 3b. Remove the special oilseal and the clutch thrust sleeve from inside the clutch housing.

NOTE: The oilseal may have to be levered from the flange, as it will have been sealed to the gearbox using "Hermitite".

- 3c. Remove the gearbox top inspection cover and with a pair of right angled circlip pliers, remove the 2" internal circlip from the pinion bearing housing as shown in illustration B6.

NOTE: It may be necessary to gently tap the end of the clutch shaft using a soft headed hammer, until the bearing is clear of the circlip. The "ears" of the circlip should be at the top of the housing; if not, turn the circlip into this position. The circlip on removal from its location will not drop into the gearbox, but will remain suspended on the clutch shaft.

- 3d. Place a 3½" long piece of 2½" o.d. tubing over the end of the clutch shaft, and by means of washers, and the clutch securing nut on the thread of the clutch shaft, draw the shaft out in stages as shown in illustration "B7a" adding more washers as necessary until the bearing releases from its housing.

NOTE: It may be necessary to prevent the clutch shaft from turning by inserting a suitable bar through the gearbox top inspection hole and into the crownwheel and pinion teeth.

Section B

Illustration 'B.6'

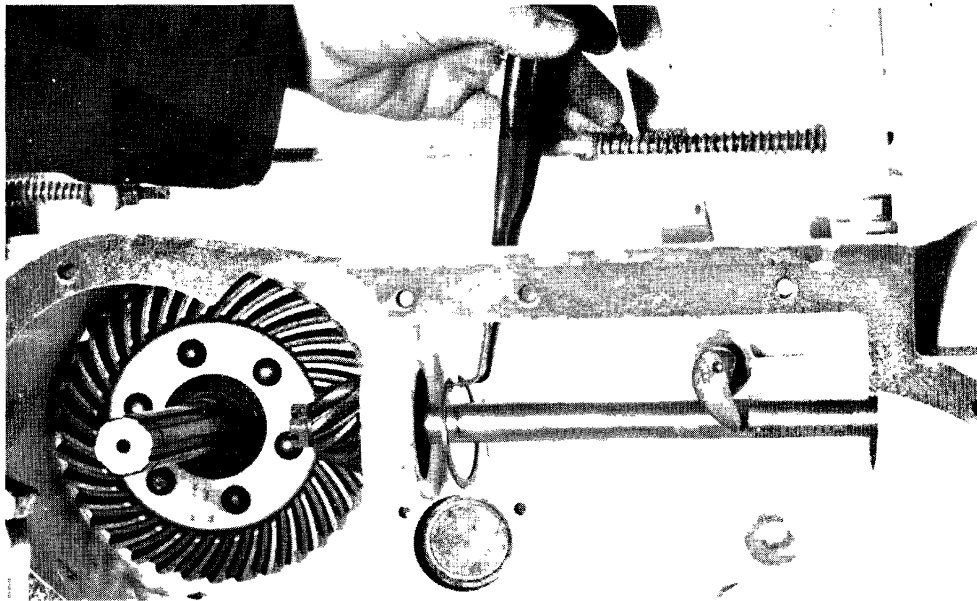

(The gearbox cover and internal components have been removed for the purpose of this photograph only.)

Illustration 'B.7a'

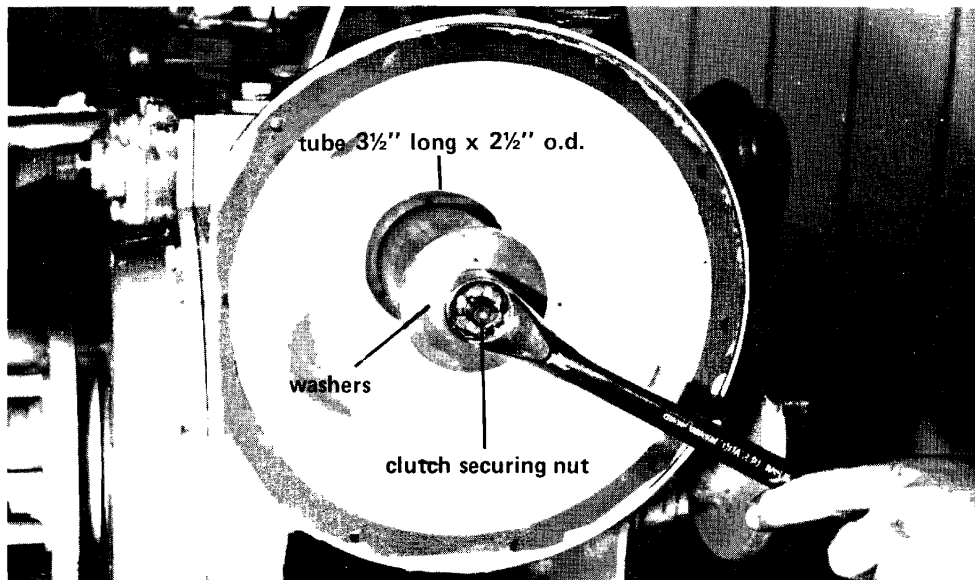
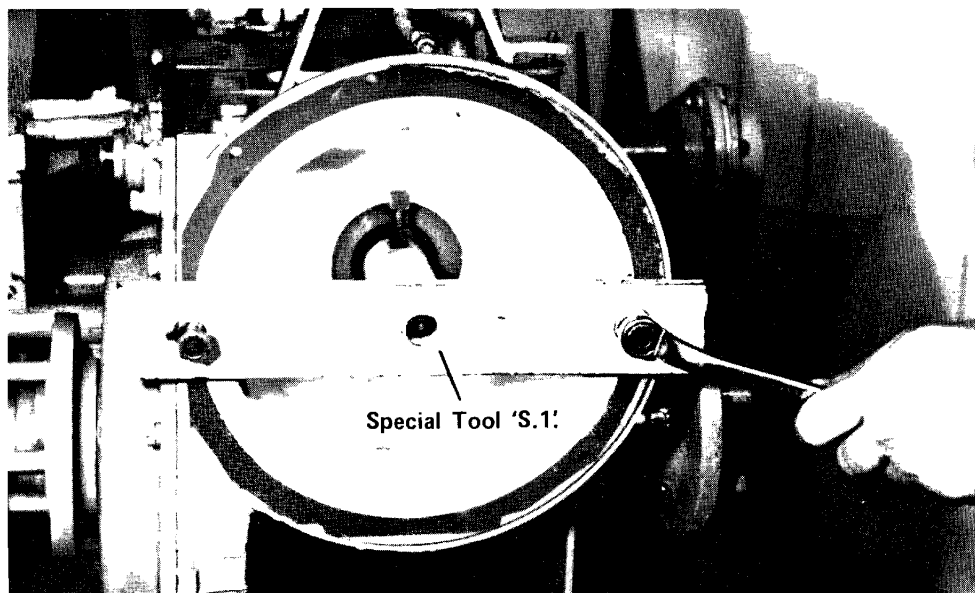

Illustration 'B.7b'



Alternatively, where the shaft is broken at a point behind the thread, position the tube part of special puller S.1 (see Section A special tools) over the clutch shaft, as shown in illustration B7b, and secure by tightening the two square headed setscrews. Then the shaft may be withdrawn by screwing in the two setscrews on the flat, front face of the puller.

NOTE: The special clutch shaft puller should not be used in cases where the same clutch shaft is to be replaced, as the square headed setscrews may score the shaft which would cause the clutch thrust sleeve to seize during operation.

- 3e. Withdraw the shaft, complete with the thrust race, circlip and bearing, through the oilseal aperture in the clutch housing.

The circlip will need to be compressed with a pair of circlip pliers before it will pass through into the clutch housing.

TO REMOVE/FIT THE CLUTCH SHAFT BEARING

To remove the bearing from a clutch shaft where the drive pinion is a separate component to the shaft; proceed as follows:

Remove the split pin and special nut from the front of the pinion, and using a workshop press, push the shaft from the pinion and bearing as shown in illustration "B.8."

To reassemble: The shaft can be pressed into the bearing, and the pinion replaced and secured by the special nut and split pin.

To remove the bearing from a clutch shaft where the drive pinion is an integral part of the shaft; proceed as follows:

Working from the back of the pinion, carefully support the outer cup of the bearing, and using a workshop press, push the shaft from the bearing as shown in illustration "B9". The shaft can then be pressed through the new bearing, until the bearing is against the shoulder at the back of the drive pinion.

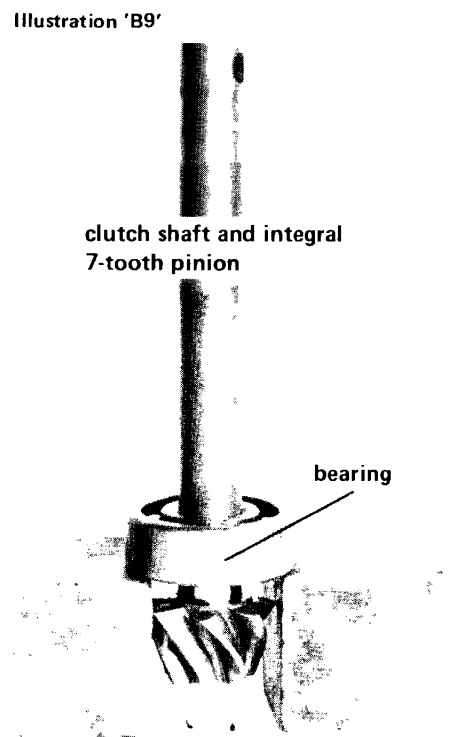
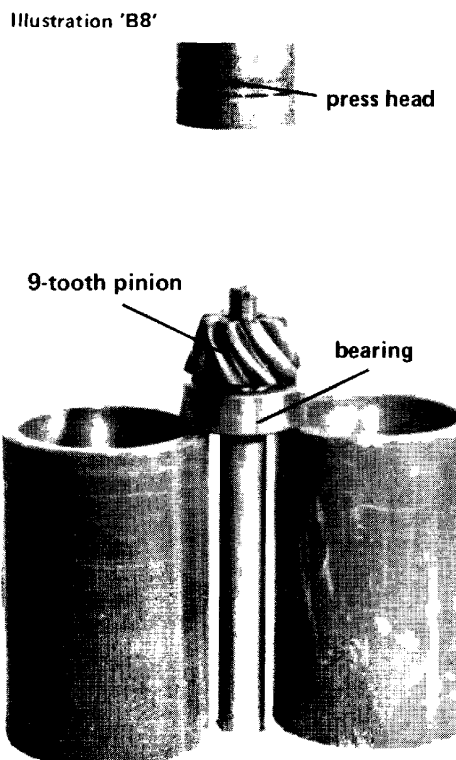

Section B

TO FIT THE CLUTCH SHAFT

4. Position the clutch shaft assembly through the oilseal hole in the clutch housing, allowing the pinion end of the shaft to drop slightly to avoid the clutch operating pawl.
- 4a. Place the retaining circlip on the clutch shaft, and using a pair of circlip pliers, ease the circlip through the oilseal hole in the clutch housing and allow it to slide up to the pinion.
- 4b. Using a soft headed hammer, tap the end of the clutch such that the bearing slides into its location.

NOTE: When tapping the bearing into its location, frequently turn the clutch shaft by hand, to ensure that the pinion does not become jammed in the crownwheel.

- 4c. Using a pair of right angled circlip pliers through the gearbox top inspection hole, secure the clutch shaft bearing in its housing using the circlip already suspended on the shaft.
- 4d. Use the "tube method" described in instruction "3d" to pull the bearing back against the circlip. The crownwheel to pinion backlash can not be checked until the clutch unit has been fitted.
- 4e. Slide the thrust bearing onto the clutch shaft and up to the operating pawl.
- 4f. Smear a small amount of "Hermitite" around the locating flange of the special oilseal. Fit the oilseal (together with the thrust sleeve) and secure in position using the 3-setscrews.
- 4g. Refill the gearbox with 6-pints (3.4 litres) of good quality SAE 90 gear oil, and refit the top inspection cover with the trough towards the pinion.

TO FIT CLUTCH UNIT

5. Position the clutch unit on the clutch shaft and slide up to the thrust sleeve, ensuring that the peg on the clutch thrust plate is positioned to the side of the raised section of the thrust sleeve. This ensures that the thrust sleeve rotates in the special oilseal during operation.
- 5a. Slide the spacer onto the clutch shaft (double plate clutches only), and secure the assembly using the special nut and split pin. When tightening the clutch retaining nut, the clutch unit should be restrained from turning using a large flat bladed screwdriver.

To check the crownwheel to pinion backlash

NOTE: Because the crownwheel to pinion backlash can only be accurately checked using a dial test indicator, when the gearbox is dismantled, the following method of assessing the backlash should only be used as a guide.

Locate the pointed special tool S.7 (see section 'A') over the clutch shaft and clutch unit securing bolts, and secure in position using $\frac{3}{8}$ " BSW nuts. Use a suitable bar through the gearbox top inspection hole to jam the crownwheel and prevent its rotation. Rotate the clutch unit backwards and forwards, and mark the furthest points of movement of the special tool, as shown in illustration B10. The distance between these marks should be approx. $\frac{1}{8}$ " (3mm) when the backlash is correct. If incorrect, the backplate and chaincase assembly must be removed so that shim may be added between the jackshaft housing and the jackshaft bearing (to decrease the backlash), or gaskets added between the jackshaft housing and the gearbox case (to increase the backlash). The backplate and chaincase assembly should then be replaced and secured, and the backlash rechecked.

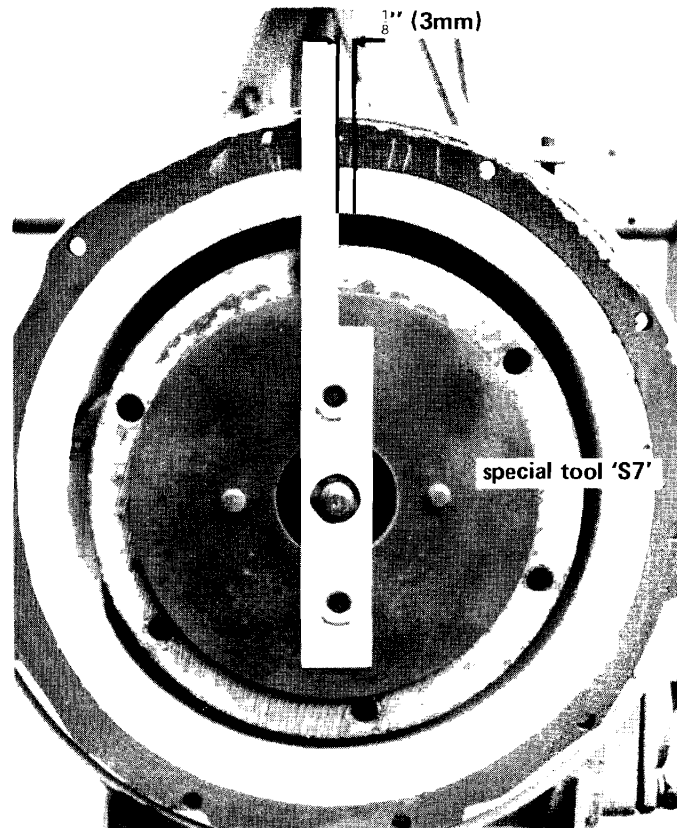

TO FIT THE ENGINE

6. When refitting the engine, engage reverse gear or secure the handle bar clutch lever in the "up" position, as this will hold the engine clutch unit in the disengaged position, and will allow free movement of the clutch disc(s) when aligning the drive adaptor pins with the holes in the friction disc(s).

To fit the Kohler engine (refer to illustration 'B1' unless otherwise stated)

- 6a. Support the engine in position such that the drive adaptor pins locate in the engine clutch, and with the bell housing location holes in line with those in the gearbox flange, secure the bell housing to the gearbox using the 8-setscrews (558). Tighten these setscrews to a torque of 10 lbs/ft. (1.3 kg/m).

DISENGAGE REVERSE GEAR BEFORE CONTINUING

- 6b. Fit the stop switch cable (573) to the engine mounted condenser.
- 6c. Fit the air cleaner hose (595) to the induction elbow and secure using the jubilee clip (594).
- 6d. Reconnect the throttle control (569) to the engine using the small clamp bolt.
- 6e. Reconnect the fuel pipe (585) to the engine, and the fuel filter bowl, and "turn on" the petrol.

NOTE: Before starting the engine, check that the oil level in the engine sump is correct (see engine handbook).

Section B

To fit the Hatz engine (refer to diagram "B2" unless otherwise stated)

- 6a. Support the engine in position such that the drive adaptor pins locate in the engine clutch, and with the bell housing location holes in line with those in the gearbox flange, secure the bell housing to the gearbox using the 8-setscrews (617).

Tighten the setscrews to a torque of 10 lbs/ft (1.3 kg/m).

NOTE: The handle clip (619) is secured to the gearbox flange using one of the setscrews (617).

DISENGAGE REVERSE GEAR BEFORE CONTINUING

- 6b. Reconnect the injector spill pipe to the engine using the small banjo bolt, with a gasket washer between the pipe and the engine and between the bolt head and the pipe.
- 6c. Reconnect the fuel line to the fuel pump on the side of the engine using a gasket washer each side of the pipe, and bleed the fuel system as described in the engine manufacturers handbook.
- 6d. Position the throttle bracket (629) against the side of the engine and secure using the 2-bolts (630).
- 6e. Reconnect the throttle cable clevis (626) to the speed control lever on the engine.

NOTE: Before starting the engine, check that the oil level in the engine sump is correct (see engine handbook).

ADJUSTMENTS

Engine

Adjustments to the engine should be made as described in the engine manufacturers handbook.

Engine clutch

Adjustment of the engine clutch is achieved by turning the wing nut on the end of the clutch control rod.

To tighten the clutch, i.e. to stop it from slipping and adjust for normal wear: the wing nut should be **unscrewed**.

To slacken the engine clutch, i.e. when it does not disengage properly: the wing nut should be **screwed** up.

When correctly adjusted there should be $\frac{3}{16}$ " – $\frac{1}{4}$ " of free movement at the operating lever (engine end of clutch rod).

Engine air cleaner

Both the Hatz and the Kohler engines use an oil bath type of air cleaner assembly, which should be cleaned daily and refilled with fresh oil. Check to ensure that the sealing surfaces are not damaged in any way. The air cleaner is one of the most important parts of the engine, and if correct servicing is carried out, will help prolong the life of the engine.

CONTENTS

<i>Subject</i>	<i>Action</i>	<i>Page</i>
AXLE BEARING STOP	Fitting	34
	Removal	21
CLUTCH SHAFT ASSEMBLY	Fitting	31
	Removal	27
CLUTCH SHAFT PINION BEARING	Fitting	27
	Removal	27
DIFFERENTIAL ASSEMBLY	Assemble	24
	Dismantle	23
DIFFERENTIAL LOCK	Assemble	23
	Dismantle	22
GEARBOX COVER	Fitting	35
	Removal	21
JACKSHAFT ASSEMBLY	Assemble	30
	Dismantle	28
	Fitting	30
	Removal	28
LAYSHAFT ASSEMBLY	Assemble	26
	Dismantle	26
	Fitting	33
	Removal	26
REVERSE IDLER GEAR	Fitting	21
	Removal	21
ROAD WHEELS	Description	20
	Fitting	35
	Removal	20
TYRES		36
WHEEL AXLE ASSEMBLY	Assembly	24
	Dismantle	22
	Fitting	33
	Removal	22
WHEEL FRICTION CLUTCHES	Fitting	35
	Removal	20

SERVICE BULLETINS APPERTAINING TO THIS SECTION ARE:—

<i>Bulletin No.</i>	<i>Date</i>

TOOLS LIST

<i>No. off</i>	<i>No. off</i>
1 ¼" BSW Box spanner	1 Copper/Rawhide mallet
1 5/16" BSW Ring spanner	1 1 lb. Ball pein hammer
1 5/16" BSW Open ended spanner	1 Large screwdriver
1 3/8" BSW Ring spanner	1 Special tool S.2
1 7/16" BSW Ring spanner	1 Special tool S.6
1 ½" BSW Ring spanner	
1 ½" BSW Open ended spanner	
1 11/16" BSW Ring spanner	
1 Pair 6" engineers pliers	
1 Pair right angled internal circlip pliers	

SPECIAL EQUIPMENT

Container/tray of at least 6 pints capacity
 Universal bearing puller (2-legged)
 Self grip wrench
 Dial test indicator and magnetic stand

Section C

ROAD WHEELS

Each road wheel, fitted with a 4.00 x 12, 2-ply traction tread pneumatic tyre, is mounted on a hub which incorporates a friction clutch device. These are adjusted, so that the wheels have sufficient grip to pull the machine, but will slip if they become jammed by an obstruction between the wheels and the frame. Single wheels are fitted as standard on the 20" and 24" models, and twin wheels on the 30" model.

Twin wheels may be fitted to the 20" machines if required, but NOT to 24" models, as the chaincase prevents the fitting of the second wheel on the left hand side of the machine.

Unless otherwise stated, all the illustration numbers in this section refer to illustration "C25", which can be found at the end of this section on page 36.

TO REMOVE THE WHEELS

1. With the machine suitably supported (on blocks etc.), proceed as follows:
 - 1a. Remove the wheel nuts (84), springs (85) and the wheel hub disc (88), and remove the wheel.

On 30" models, remove the extension hub (130) and then the inner wheel. Removal procedure is the same for left and right hand wheels.

To refit the wheels – see instruction 16.

TO REMOVE THE WHEEL HUBS

2. Remove the wheels as previously described in instruction '1', then proceed as follows:
 - 2a. The right hand wheel hub (89) is secured to the wheel axle by a special hub nut (87). Removal of this hub nut will allow the wheel hub to be withdrawn from the axle with the aid of a 'hub puller', as shown in illustration "C1" (see special tool S2 section A).

Illustration "C.1"

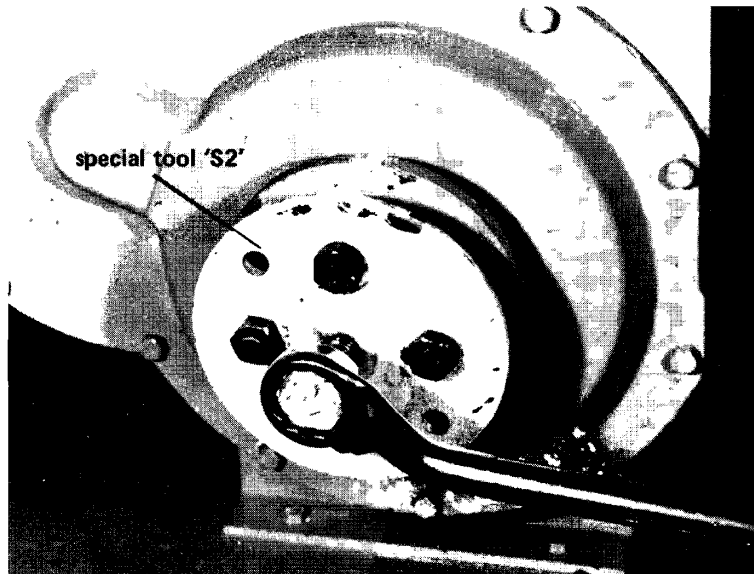

The left hand wheel hub (118) is secured to the wheel axle by a split pin (121) and a special nut (120). Removal of these and the backing washer (119) will allow the wheel hub to be withdrawn from the axle with the aid of a 'hub puller' in a similar manner to that shown in illustration "C1" (see special tool S2 section A).

To refit the wheel hubs – see instruction 15.

TO REMOVE THE AXLE BEARING STOP (115)

Drain the oil from the gearbox (a container of at least 6 pints capacity will be required). Remove the left hand wheel and hub as previously described in instructions 1 and 2, then proceed as follows:

3. Remove the 4-setscrews (117) and spring washers (116) which secure the bearing stop to the main gearbox casing.

NOTE: The oilseal (113) should always be renewed before refitting the bearing stop.

To refit the axle bearing stop – see instruction 13.

TO REMOVE THE GEARBOX COVER (24)

4. Drain the oil from the gearbox (a container of at least 6 pints capacity will be required). Remove the right hand wheel and hub as previously described in instructions 1 and 2. Remove the starting handle, then proceed as follows:
 - 4a. Remove the setscrews (22) and spring washers (23) from the starter dog bearing housing (21), and remove the housing complete with its gasket and starter dog (19).
 - 4b. Remove the setscrews (26) and spring washers (27) from around the perimeter of the gearbox case.
 - 4c. With the aid of a flat bladed screwdriver, prise the gearbox cover from the main gearbox casing.

The cover is located on 2-dowel pins, and may be difficult to move at first.

Reverse idler gear assembly – to remove.

Having removed the gearbox cover as previously described, proceed as follows:

Remove the $\frac{1}{2}$ " BSF philidas nut (38) and the flat washer from the reverse idler pin (34).

Withdraw the idler pin from its location in the gearbox cover, complete with the reverse idler gear (35).

If the idler gear bush (36) is to be replaced, it should be pressed out with the aid of a $\frac{3}{4}$ " dia. soft brass drift. The new bush may then be pressed into the reverse gear until flush with the gear faces. Two $\frac{5}{16}$ " dia. oil holes should then be drilled in the bush, working through the existing holes in the idler gear. The bush will then have to be reamed to a diameter of 0.627"/0.629" to remove the burrs caused by drilling, and to ensure correct bore size.

Reverse idler gear assembly – to fit

Insert the idler pin (34) through the idler gear (35) so that the smaller 12-tooth gear is against the head of the pin. Locate the pin in the gearbox cover, and secure using the flat washer (37) and philidas nut (38).

Wheel axle oilseal (90)

The wheel axle oilseal, located in the gearbox cover, should be removed before refitting the cover to the main gearbox case, so that a new oilseal may be used on assembly. The old seal may be pressed out with the aid of a $2\frac{5}{8}$ " dia. drift.

To refit the gearbox cover – see instruction 14.

Section C

TO REMOVE THE WHEEL AXLE ASSEMBLY

5. Having removed the wheels and hubs, axle bearing stop and gearbox cover as previously described in instructions 1-4, proceed as follows:
 - 5a. Remove the retaining split pin from the differential lock control quadrant pivot pin and slide the pivot pin out of the control quadrant as far as possible and remove the locknuts and trunnion (shown in illustration "C2") from the differential lock selector.
 - 5b. Remove the split pin (40) and special nut (39) from the end of the layshaft (50), and remove the bearing (41).

Illustration "C.2"



- 5c. While supporting the axle by hand, tap the axle assembly from its location in the main gearbox casing, using a soft headed hammer as shown in illustration "C3".

Illustration "C.3"

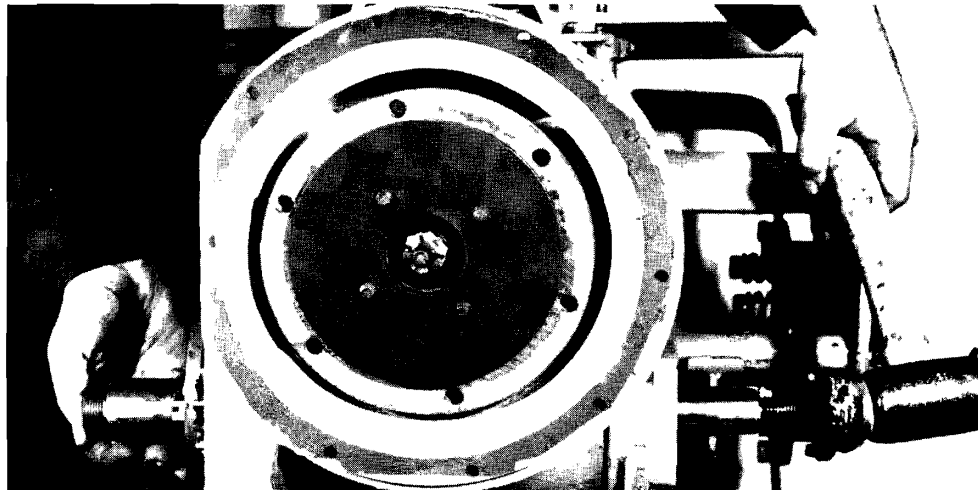

(The engine has been removed for the purpose of this photograph only)

NOTE: On removal of the axle assembly, the differential lock selector will also be removed from its location.

TO DISMANTLE THE AXLE ASSEMBLY

Remove the axle bearing (110) from the end of the axle shaft using a universal bearing puller, as shown in illustration "C4", so that the differential lock assembly may be removed.

TO DISMANTLE THE DIFFERENTIAL LOCK

Remove the locking wire (105) from the setscrews (104), and remove these setscrews.

NOTE: The differential lock assembly will fall apart on removal of these setscrews, and care should be taken to avoid losing the 3-spacers (106).

Illustration "C4"

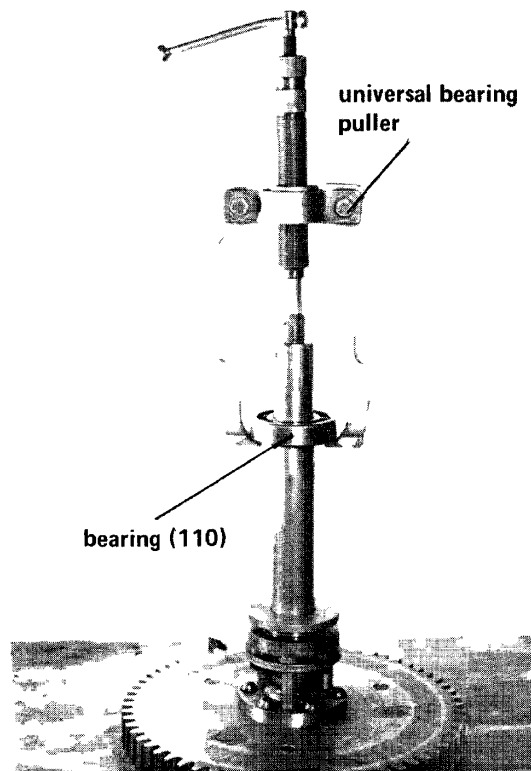

TO ASSEMBLE THE DIFFERENTIAL LOCK

Insert the 3-differential lock pins (107) through the ring (103), and while holding the differential pins to prevent them falling out, invert the ring and pass the setscrews (104) through the ring from the opposite side to the pin heads. Position one spacer (106) over each threaded hole in the differential lock (108), and while holding the ring (103) in position over the differential lock, screw the setscrews through the spacers and into the differential lock. Fully tighten the setscrews and secure using a 9" long piece of 16 SWG locking wire.

TO DISMANTLE THE DIFFERENTIAL ASSEMBLY

Remove the split pins (93) and the special nuts (92) from the pinion studs (99) and, using a piece of wood, lever the differential plate from the studs as shown in illustration "C5".

Remove all 6 differential pinions (97) and the loose hub gear (96) from the axle.

Illustration "C5"

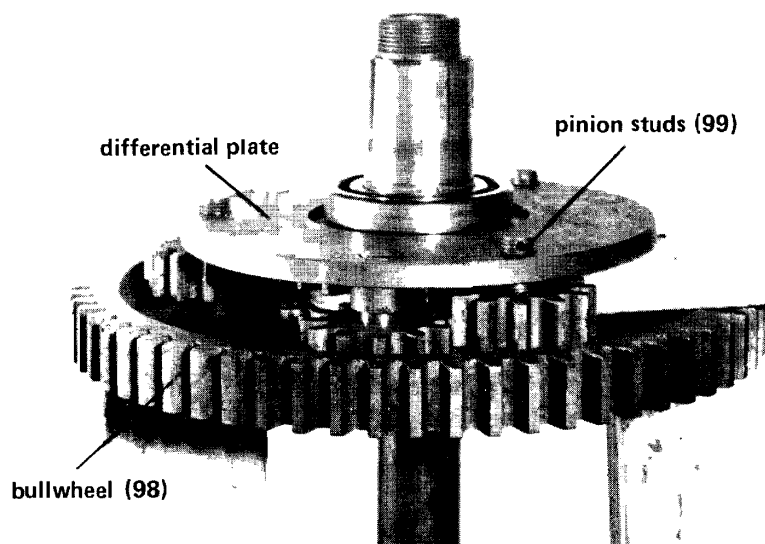

Section C

If the loose hub gear bearing (91) is to be replaced, a special tool S3, similar in appearance to the differential lock assembly, will be required in order to be able to press the bearing from its location. Using the special tool S3 (see special tools section 'A') working from the back face of the loose hub gear through the holes provided in the gear flange, press the bearing from its location as shown in illustration "C6".

The loose hub gear can then be pressed through the new bearing using an ordinary workshop press.

Withdraw the wheel axle and fixed hub rivet assembly from the bullwheel (98). The fixed hub gear (100) is secured to the wheel axle flange by 6 rivets (102). If for any reason these rivets are removed, the new rivets should be inserted from the axle flange side of the fixed hub gear, and burred over on the fixed hub gear side. The burrs must then be ground flat to prevent them fouling the loose hub gear when the differential unit is reassembled. If the pinion pins (95) located in the differential plate (94) are to be replaced the new pins should be burred over to secure.

The pinion studs (99) in the bullwheel, if replaced, must have the burred ends ground flat to prevent them fouling on the small gear (44), on the layshaft (50) when the gearbox is reassembled.

Illustration "C6"

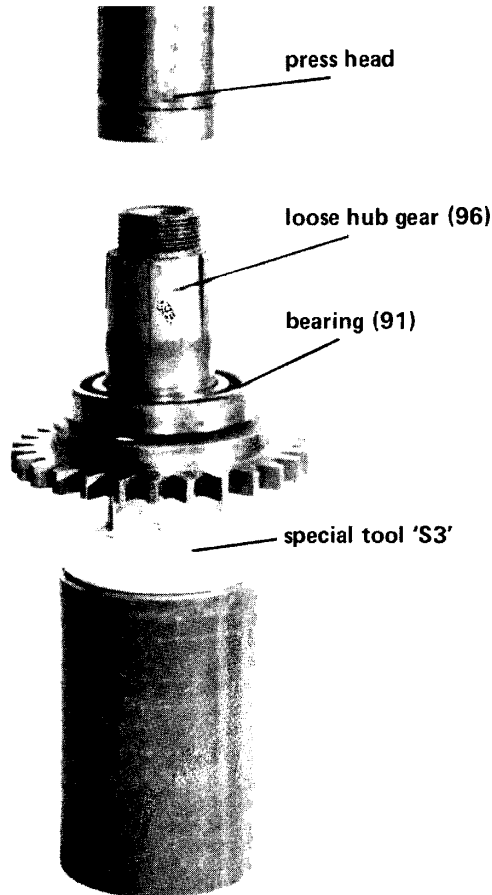

TO ASSEMBLE THE DIFFERENTIAL UNIT

Position the wheel axle and fixed hub gear rivet assembly through the bullwheel (98), from the differential pinion stud side, such that the fixed hub gear locates in the centre of the bullwheel (as shown in illustration "C7"). Locate one differential pinion (97) on each pinion stud on the bullwheel. Position the loose hub gear (96), complete with bearing (91), over the end of the wheel axle, checking that it is free to rotate against the fixed hub gear. Position the remaining differential pinions on the bullwheel as shown

in illustration "C8", such that they mesh with the fixed hub gear, the existing differential pinions and that they are positioned over their respective pinion pin location holes. Invert the differential plate (94) and fit to the bullwheel such that the pinion pins (95) locate through the differential pinions and into the bullwheel. Tap the plate to fully locate, and secure using the special nuts (92) and split pins (93). Slide the differential lock assembly onto the wheel axle and check that it engages in the fixed and loose hub gears. With the aid of a piece of 1 $\frac{3}{4}$ " ID. tubing, tap the bearing (11) onto the end of the axle shaft.

To refit the axle assembly into the gearbox – see instruction 12.

Illustration "C7"

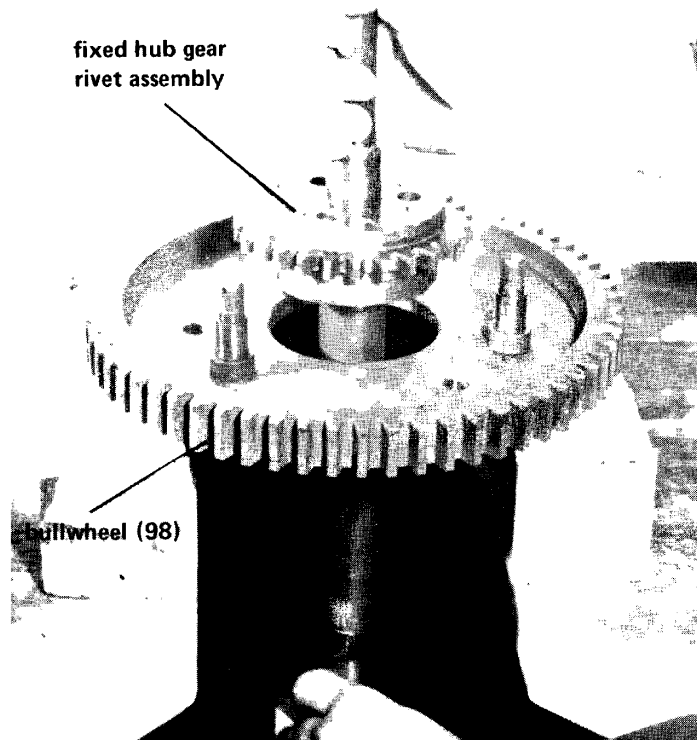
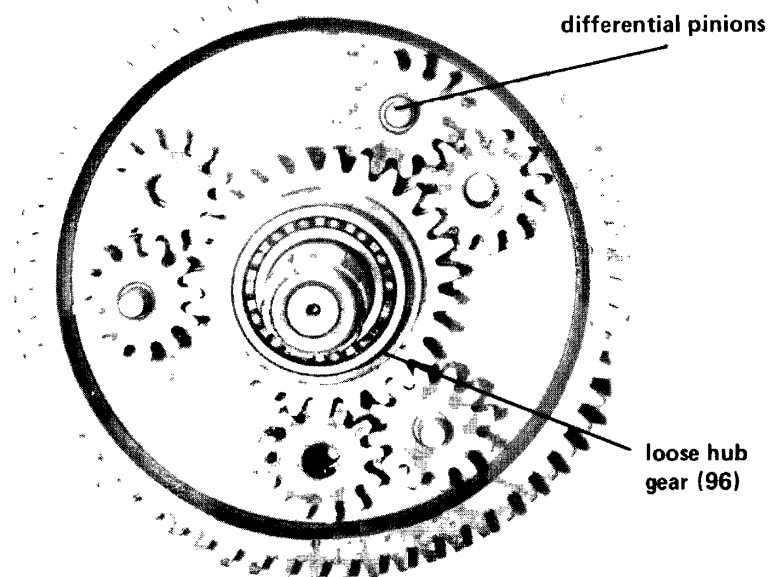

Illustration "C8"



Section C

TO REMOVE/DISMANTLE THE LAYSHAFT

6. Remove the wheels and hubs, gearbox cover, axle bearing stop, axle assembly, top inspection cover and the dipstick as previously described, then proceed as follows:
 - 6a. Remove the bull pinion (43), small gear (44) and spacer (46) from the layshaft, and retain any shims which may have been fitted.
 - 6b. Remove the bearing stop (54) from the gearbox casing, and while supporting the layshaft by hand, tap the layshaft from its location. Remove the medium gear (48) and large gear (49).

If the layshaft bearing (51) is to be renewed, a universal puller should be used as shown in illustration "C9". The shaft can then be pressed into the new bearing using an ordinary workshop press.

Illustration "C9"

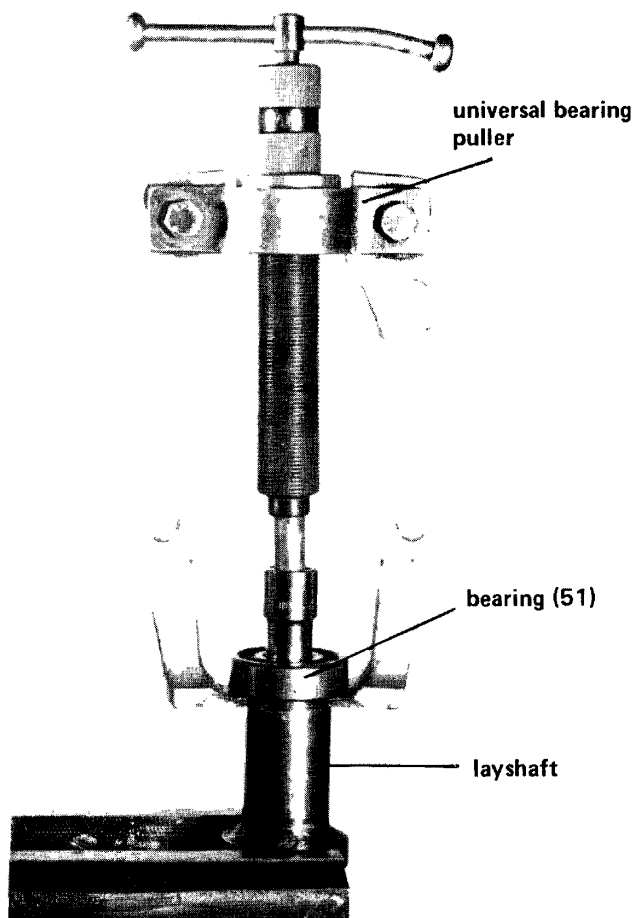

TO ASSEMBLE THE LAYSHAFT

Position the large gear (49) and medium gear (48) on the layshaft. The combined width of these gears should be 1". Add shims (47) between the two gears until this measurement is achieved.

Position the spacer (46) on the layshaft against the medium and large gears. The small gear (44) should be ½" wide, and shims (45) should be placed against the spacer (46), as necessary to achieve this measurement. Fit the small gear and bull pinion onto the layshaft.

To refit the layshaft.— see instruction 11.

TO REMOVE THE CLUTCH SHAFT

7. If the clutch shaft is to be removed without dismantling the gearbox follow the method described in section 'B' instruction 3.

However, if the clutch shaft is broken and the gearbox has to be dismantled, check that the engine and engine clutch (see section 'B'), gearbox cover, wheel axle and layshaft assemblies have all been removed, then proceed as follows:

- 7a. Remove the special oilseal (68) and thrust sleeve (66) from the clutch housing, and slide the thrust bearing (65) from the shaft.
- 7b. Remove the circlip (63) from the pinion bearing housing, and using a self grip wrench, remove the shaft as shown in illustration "C10".

Illustration "C10"

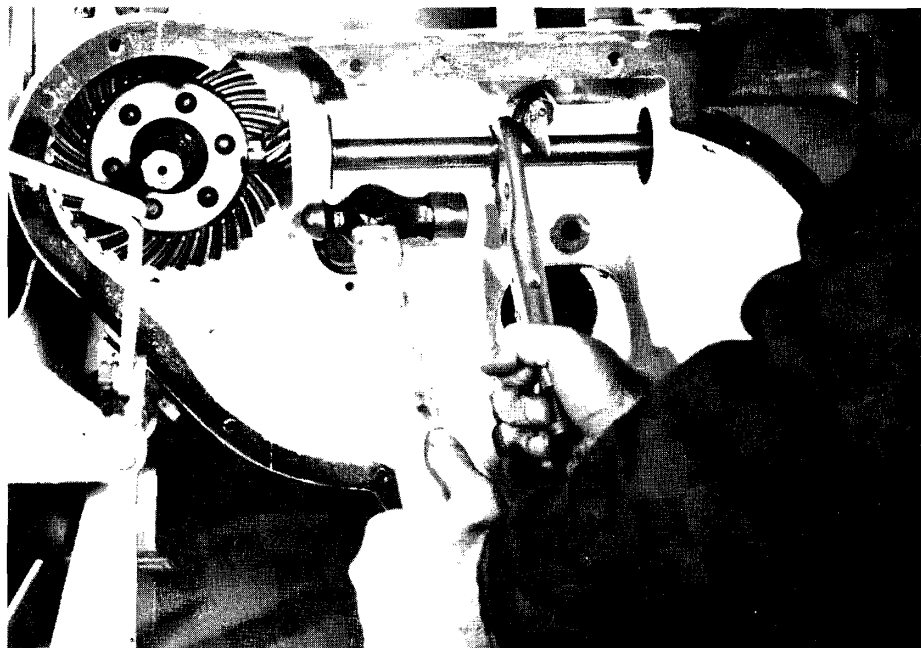

To remove the pinion bearing

To remove the bearing from a clutch shaft where the pinion is a separate component to the clutch shaft, proceed as follows:

Remove the split pin and special nut from the front of the pinion and using a workshop press, push the shaft from the pinion and bearing as shown in illustration "C11".

To reassemble: The shaft can be pressed into the bearing, and the pinion replaced and secured by the special nut and split pin.

To remove the bearing from a clutch shaft where the drive pinion is an integral part of the shaft proceed as follows:

Working from the back of the pinion, carefully support the outer cup of the bearing, and using a workshop press, push the shaft from the bearing as shown in illustration "C12".

To reassemble: The shaft can be pressed through the new bearing until it is against the shoulder at the back of the pinion.

To refit the clutch shaft – see instruction 10.

Section C

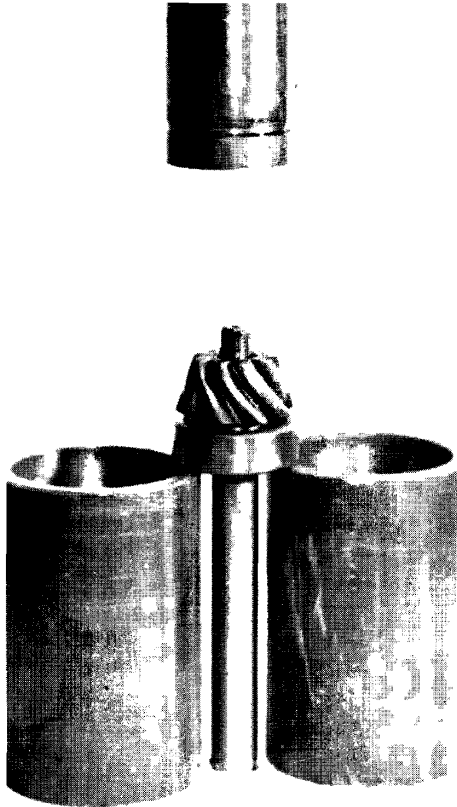

Illustration "C11"

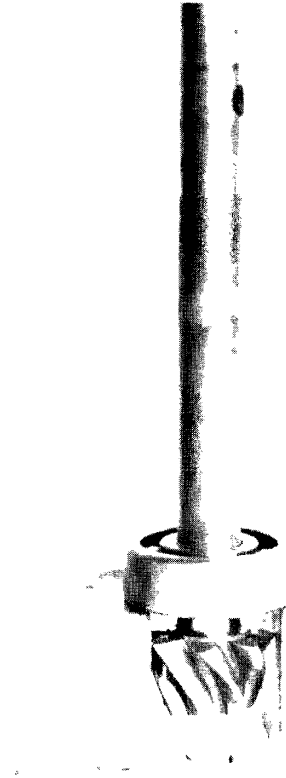
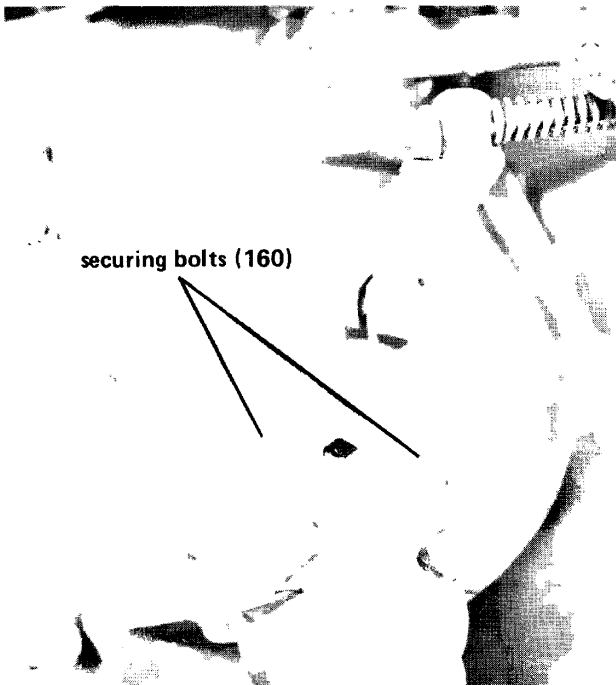

Illustration "C12"

TO DISMANTLE/REMOVE THE JACKSHAFT

8. Remove the engine and engine clutch (see section 'B'), wheels and hubs, gearbox cover, wheel axle assembly, layshaft assembly and clutch shaft, then proceed as follows:
 - 8a. Remove the bolts (160) which secure the rotor dog clutch selector housing to the jackshaft housing (shown in illustration "C13") and move the selector housing aside.

Illustration "C13"



- 8b. Remove the starter dog bearing (18) from the end of the jackshaft (12) and remove the special circlip.
- 8c. Slacken the retaining screw on the reverse gear selector arm, shown in illustration "C14" and remove the arm and joint block, taking care to retain the locating key.

Illustration "C14"

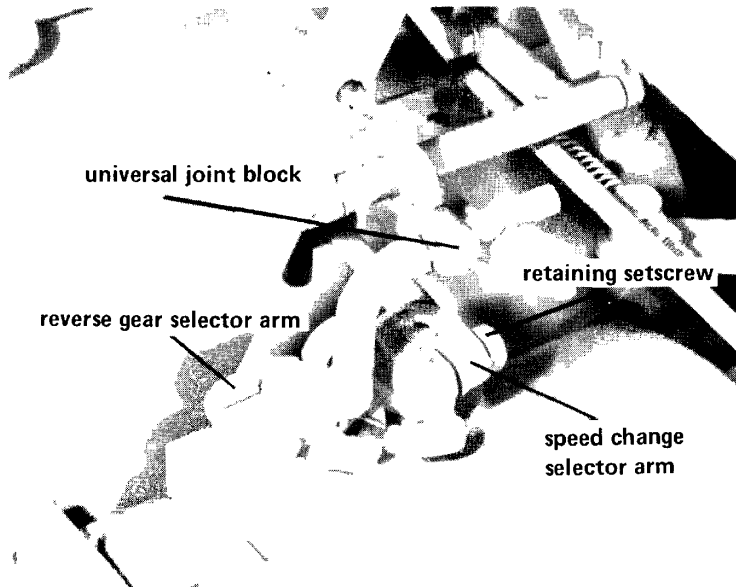

- 8d. Remove the selector bush (3A) and withdraw from the gearbox the reverse selector together with the single pinion (17).

NOTE: Shims may be fitted to the reverse selector, if so they should be retained as they may be required on assembly.

- 8e. Slacken the speed change selector arm retaining screw, shown in illustration "C14" and remove the arm and joint block, taking care to retain the locating key.

- 8f. Remove the selector bush (3) and slide the double pinion (16) from the jackshaft together with the speed change selector.

NOTE: Shims may be fitted to the speed change selector, if so they should be retained as they may be required on assembly.

- 8g. Using a hammer, and a soft brass drift through the rotor dog clutch selector housing, tap the jackshaft from its location as shown in illustration "C15". The jackshaft may then be removed from the gearbox together with the rotor clutch dog and shims.

Illustration "C15"

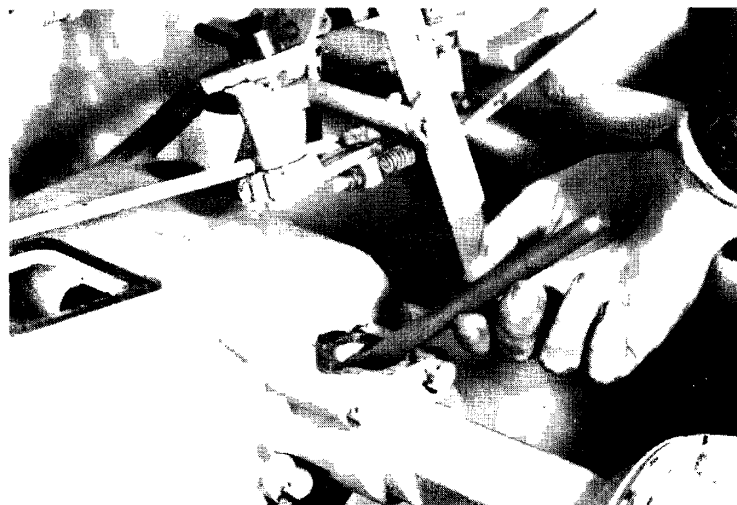

Section C

The bearing (11) may be partially removed from the jackshaft with the aid of special tool S.6 (see section 'A') as shown in illustration "C16". The bearing may then be removed completely using a universal bearing puller.

Illustration "C16"

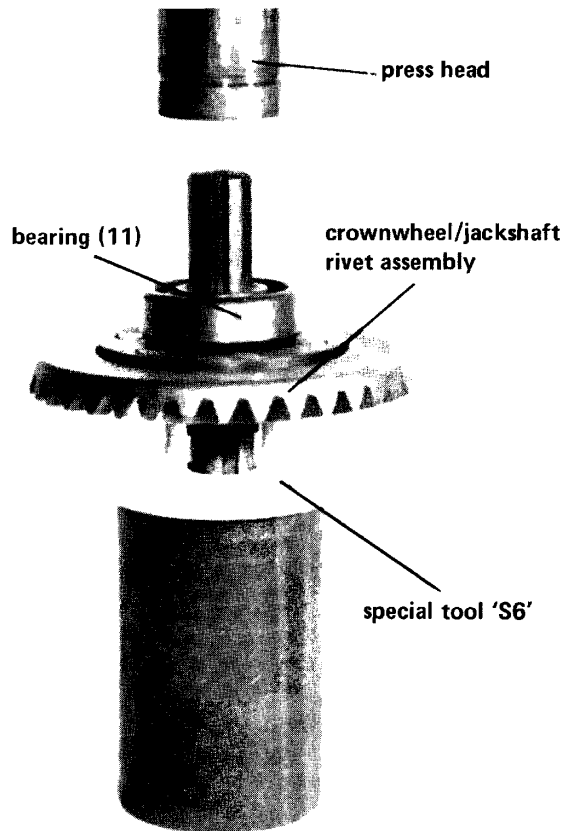

Special note: The crownwheel (13) is secured to the jackshaft (12) by 6-rivets (14). If the rivets are removed, the new rivets should be inserted from the crownwheel side, and burred over on the jackshaft flange. These burrs should then be ground flat to prevent them from fouling the gearbox casing on reassembly. The new bearing may then be pressed onto the jackshaft with the aid of a piece of $1\frac{1}{16}$ " ID. tube.

NEXT: Fit/assemble the jackshaft as described in instruction 9.

TO FIT/ASSEMBLE THE JACKSHAFT

9. Place 2-shims (10) onto the jackshaft against the bearing (11). Slide the rotor clutch dog onto the jackshaft and up to the shim.
- 9a. Using a soft headed hammer, tap the jackshaft and bearing into its location in the gearbox casing, as shown in illustration "C17".

NOTE: It is advisable to fit the clutch shaft at this stage so that the correct crownwheel to pinion backlash may be achieved. To fit the clutch shaft and adjust the backlash, refer to instructions 10 to 10c inclusive. When the backlash is correct, proceed as follows:

- 9b. Fit and secure the rotor dog clutch selector housing, using the bolts (160) shown in illustration "C13."
- 9c. Slide the double pinion (16) onto the jackshaft, small gear first. Fit the speed change selector (29), such that the selector block locates in the double pinion and in the gearbox case. Secure in position using the selector bush (3).

Illustration "C17"

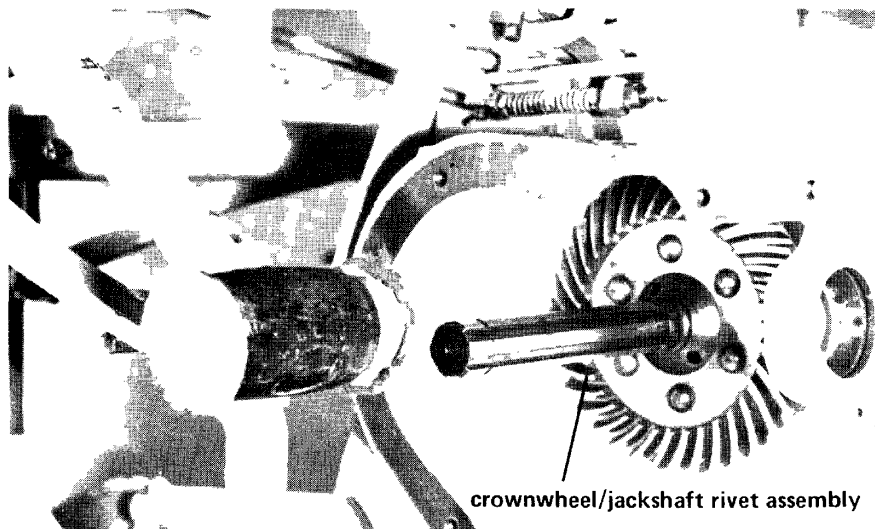

NOTE: The speed change selector should have approx. $\frac{1}{32}$ " free movement up and down. This may be achieved by adding washers (31) between the selector bush and the selector, to decrease the movement, or by adding shims (3B) between the selector bush and the gearbox case to increase the free movement.

- 9d. Slide the single pinion (17) onto the jackshaft, gear side outermost. Fit the reverse selector (30) such that it locates in the groove in the single pinion.

NOTE: The reverse selector should have approx. $\frac{1}{32}$ " free movement up and down. This may be achieved by adding washers (31) between the selector bush and the selector to decrease the movement, or by adding shims (38) between the selector bush and the gearbox case to increase the free movement.

- 9e. Fit the special circlip (15) to the end of the jackshaft and position the starting dog bearing (18) over the end of the jackshaft.
- 9f. Fit the gear change selector arms, and check that the interlock plates on the arms function correctly.

NEXT: Fit the remaining clutch assembly parts as described in instruction 10c. onwards.

TO FIT THE CLUTCH SHAFT

10. Position the clutch shaft through the oilseal hole in the clutch housing and using a soft headed hammer, tap the shaft into its location as shown in illustration "C18".

When tapping the clutch shaft into its location, frequently turn the clutch shaft by hand to ensure that it does not become jammed in the crownwheel.

- 10a. Secure the shaft bearing in position using the circlip (63), and position the 'ears' of the circlip at the top.
- 10b. To obtain the correct backlash (0.010") between the crownwheel and pinion proceed as follows:

Position a $3\frac{1}{2}$ " long piece of $2\frac{1}{2}$ " OD. tubing over the clutch shaft and, by means of the clutch securing nut, some washers and the thread on the clutch shaft, draw the pinion out of mesh with the crownwheel as shown in illustration "C19", until the circlip prevents further movement.

Section C

Illustration "C18"

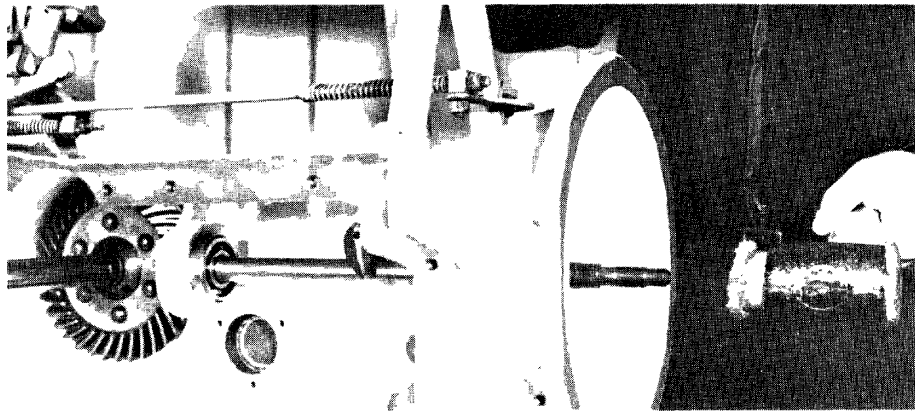
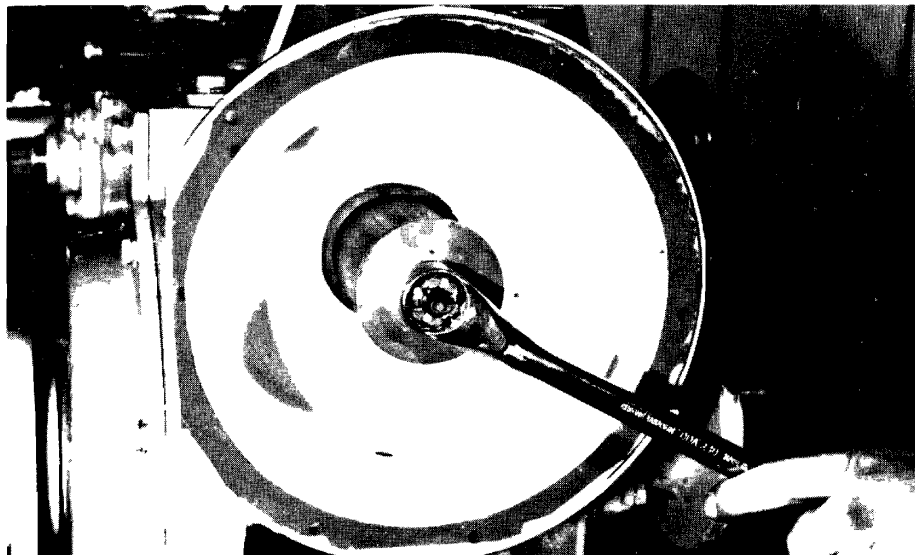

Illustration "C19"



While holding the clutch shaft to prevent its rotation, gently turn the jackshaft backwards and forwards, and using a dial test indicator, check the total backlash as shown in illustration "C20". If the backlash is not correct, the clutch shaft and the jackshaft will have to be removed so that shim may be added (to decrease backlash) or removed (to increase backlash) from behind the jackshaft bearing.

The jackshaft and the clutch shaft should then be replaced and the backlash rechecked.

Refer to instructions 9b. to 9f. inclusive, for the sequence of assembling the jackshaft.

Illustration "C20"

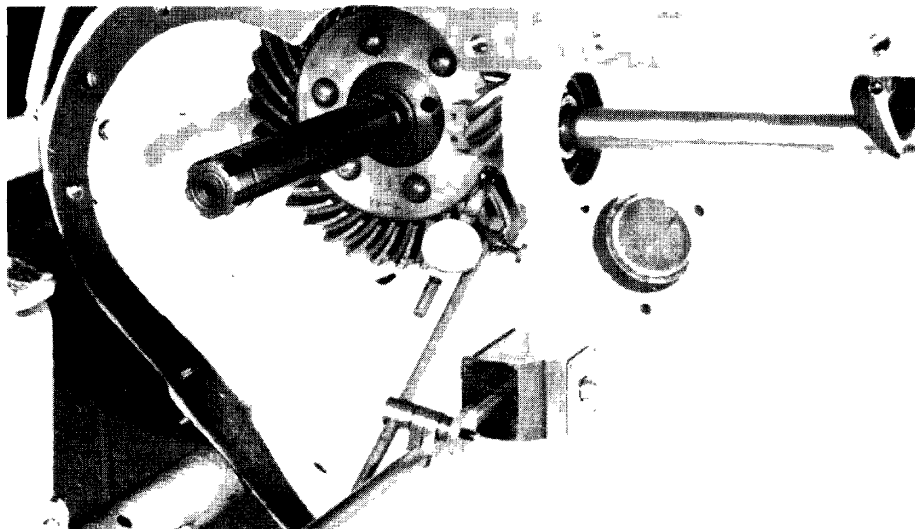

- 10c. Check that the clutch shaft bearing retaining circlip (63) has been fitted, and that the jackshaft assembly is complete, then slide the thrust bearing (65) onto the clutch shaft and up to the operating pawl.
- 10d. Position the thrust sleeve (66) through the special oilseal (68) taking care not to damage the rubber lip of the seal. Apply a small amount of 'Hermetite' around the locating flange of the oilseal. Locate the thrust sleeve over the clutch shaft and secure the oilseal to the main gearbox case using the 3-screws (69).
- 10e. Refit the engine clutch and engine as described in section 'B'.

NEXT: Fit the layshaft assembly as described in instruction 11.

TO FIT THE LAYSHAFT

11. Fit the layshaft bearing stop (54) complete with gasket (53), and secure using the 3-setscrews (56).
- 11a. Position the layshaft and bearing assembly, and using a soft headed hammer, tap the assembly into its location as shown in illustration "C21".

Illustration "C21"

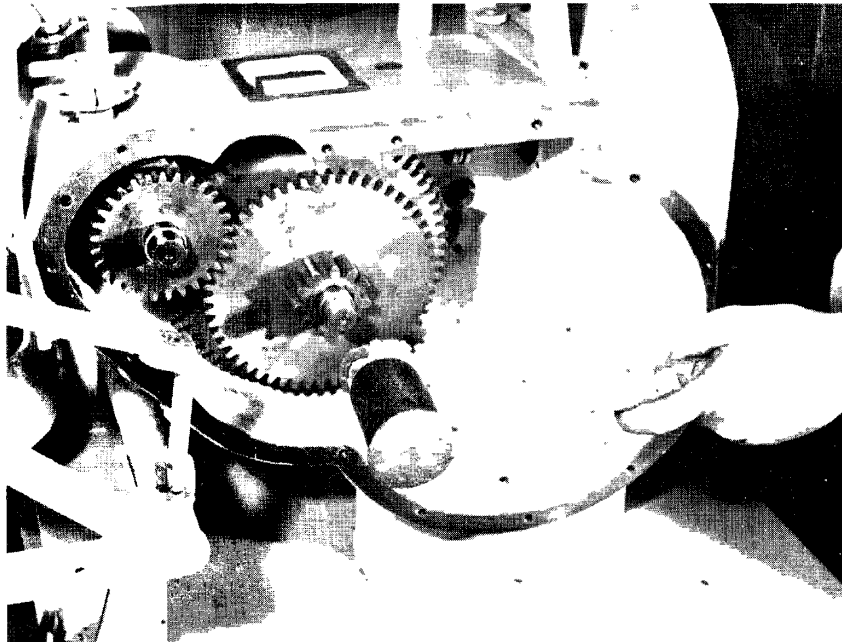

NEXT: Fit the wheel axle assembly as described in instruction 12.

TO FIT THE WHEEL AXLE ASSEMBLY

12. Check that the differential lock selector (109) is straight and square, and that it slides freely in its location in the gearbox case. Remove from the gearbox and position the fork in the slot in the differential lock assembly.
- 12a. Position the axle assembly in the gearbox casing such that the differential lock selector locates in the gearbox and the pins of the differential lock locate through the back of the bullwheel.

While supporting the assembly, as shown in illustration "C22" tap the axle bearing into its location.

- 12b. With the aid of a piece of $1\frac{1}{16}$ " OD. tube, tap the bearing (41) onto the end of the layshaft (50), and secure using special nut (39), and a split pin.

Section C

Illustration "C22"

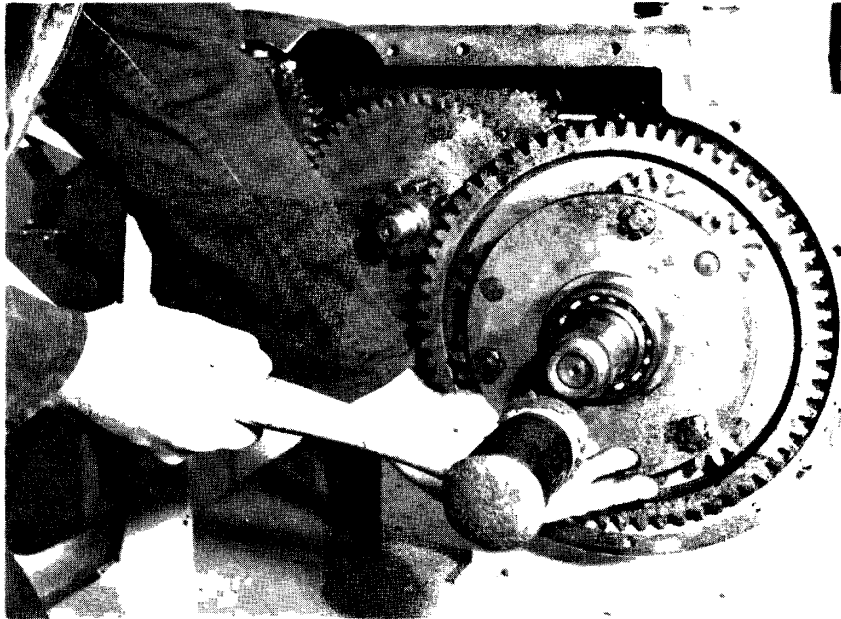

NOTE: When tightening the special nut, the layshaft gears should be jammed using a suitable bar through the top inspection hole, so that the gears cannot rotate.

12c. Fit the locknuts and trunnion shown in illustration "C2" and refit the differential control quadrant.

NEXT: Fit the axle bearing stop as described in instruction 13, and the gearbox cover as described in instruction 14.

TO FIT THE AXLE BEARING STOP (115)

13. Fit a new oilseal into the bearing stop, and using metal shim or tape to protect the oilseal against the wheel axle splines, slide the bearing stop up to the gearbox case as shown in illustration "C23". Secure the bearing stop using the 4-setscrews (117).

NOTE: To prevent the possibility of an oil leak through the setscrews, they should be coated with "Hermatite" before securing the bearing stop.

Illustration "C23"

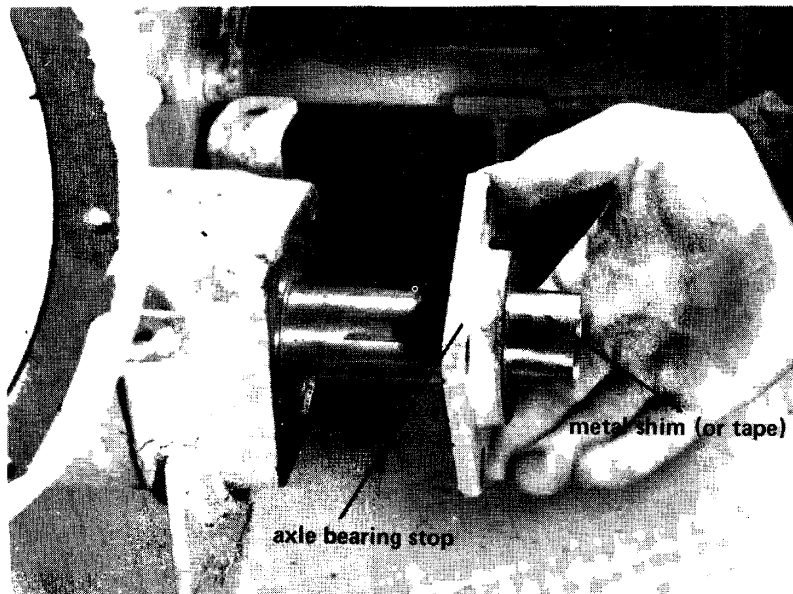

(The engine has been removed for the purpose of this photograph only).

NEXT: Fit the left hand wheel hub as described in instructions 15 and 16.

TO FIT THE GEARBOX COVER

14. Position the gearbox cover (24), against the gearbox casing so that the starting dog bearing (18), layshaft bearing (41) and wheel axle bearing (91) locate correctly. Tap the cover into position, and locate using the 2-dowel pins (28). Fully secure the cover using the setscrews (26) around the perimeter of the gearbox.

NOTE: Fit the top inspection cover (5), with the trough towards the pinion, to prevent foreign matter from entering the gearbox. Fit the oil dipstick.

- 14a. Fit a new oilseal (90) into the gearbox cover, using metal shim or tape to protect the oilseal against the splines on the loose hub gear as shown in illustration "C24", and tap into position with the aid of a $1\frac{7}{8}$ " ID. piece of tube.

Illustration 'C24'

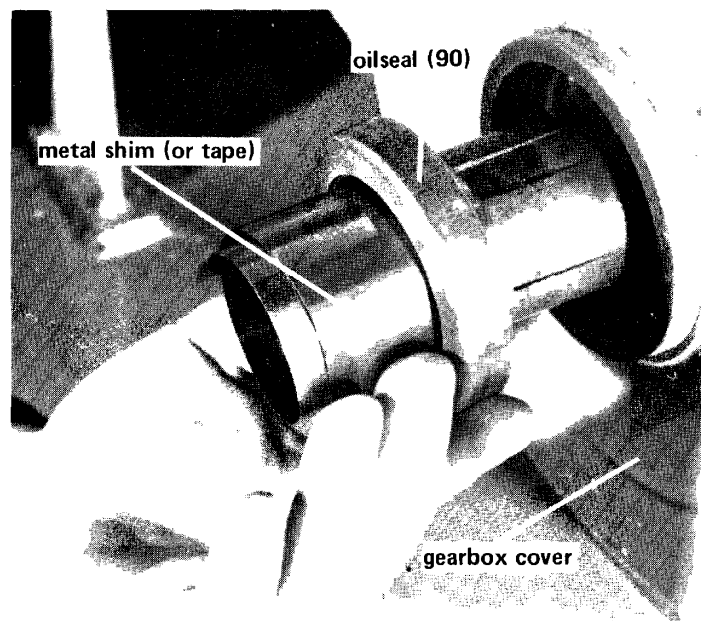

- 14b. Fit the starter dog bearing housing (21) complete with the starting dog (19), and secure using the setscrews (22).

NEXT: Fit the right hand wheel and hub as described in instructions 15 and 16.

TO FIT THE WHEEL HUBS

15. Position the left hand wheel hub (118) over the wheel axle and secure using the washer (119) and special nut (120). Fully tighten the nut, and lock using a split pin (121).

The right hand wheel hub (89) is secured by a special hub nut (87) which should be fully tightened.

TO FIT THE WHEELS

16. Position the wheel over the spigot on the wheel hub, (if double wheels are fitted, slide the extension hub over the wheel studs and up to the wheel centre then fit the second wheel over the spigot on the extension hub).

- 16a. Fit the wheel hub disc (88) over the wheel studs, and secure with the springs (85) and nuts (84).

Section C

WHEEL FRICTION CLUTCHES:

Tighten the wheel nuts so that the springs are fully compressed, then slacken back each nut half a turn. This will ensure that the safety clutch device will operate correctly. Should the wheel hubs slip when the machine is in normal use, tighten the wheel nuts evenly until sufficient grip is acquired to produce forward movement of the machine.

TYRES:

Check that the tyre pressure is correct – 20 psi. (1.4 kg/sq.cm.), and that the tyres are in good condition.

Adjustments to the gear selectors and the differential control, should be made as described in section 'D', ADJUSTMENTS.

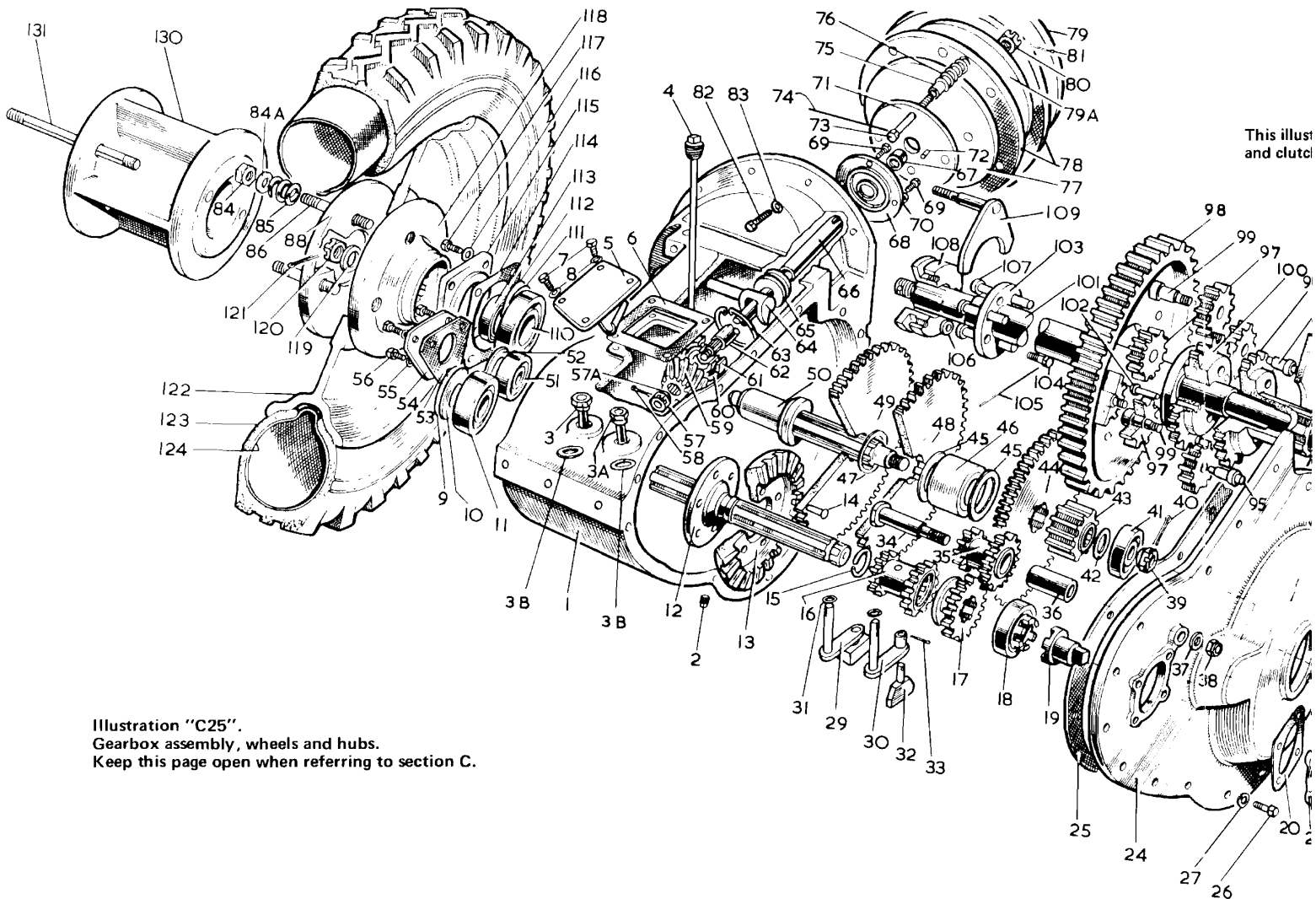
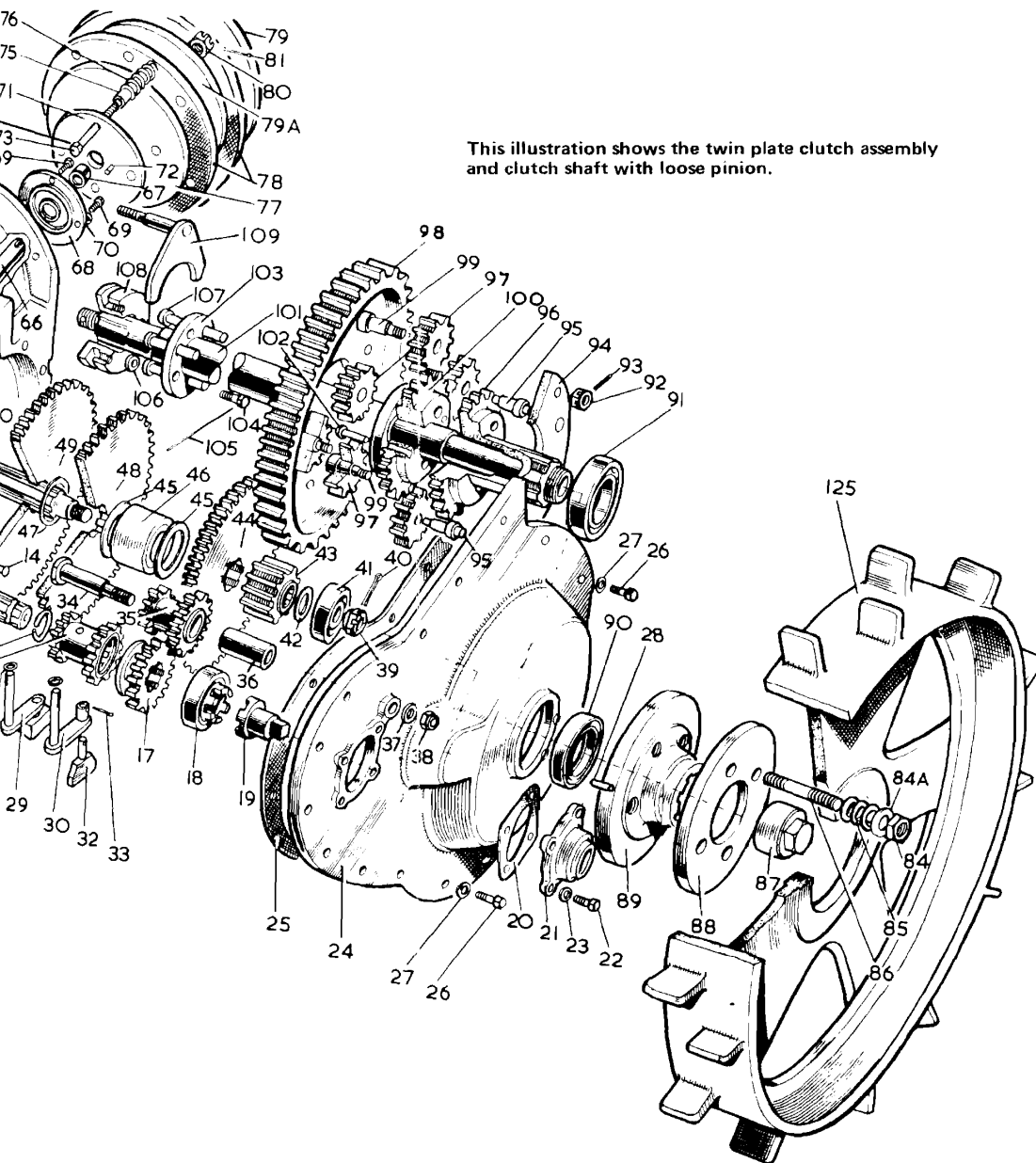

Illustration "C25".
Gearbox assembly, wheels and hubs.
Keep this page open when referring to section C.

compressed, then slacken
safety clutch device will
the machine is in normal
is acquired to produce

.4 kg/sq.cm.), and that

control, should be made



This illustration shows the twin plate clutch assembly and clutch shaft with loose pinion.

CONTENTS

<i>Subject</i>	<i>Action</i>	<i>Page</i>
CLUTCH	Adjustment	43
CLUTCH CONTROL ARM	Fitting	42
	Removal	42
CLUTCH CONTROL ARM ROD	Fitting	40
	Removal	40
CLUTCH CONTROL HAND LEVER	Fitting	42
	Removal	42
CLUTCH CONTROL PIVOT LEVER ROD	Fitting	40
	Removal	40
DIFFERENTIAL CONTROL ARM	Fitting	38
	Removal	38
DIFFERENTIAL CONTROL ROD	Fitting	38
	Removal	38
DIFFERENTIAL LOCK DIFFERENTIAL/ROTOR HAND CONTROL LEVER	Adjustment	44
	Fitting	39
	Removal	39
GEAR CHANGE CONTROL TUBE	Fitting	41
	Removal	40
GEAR CHANGE GATE	Fitting	40
	Removal	40
GEAR CHANGE LEVER	Fitting	40
	Removal	40
GEAR CHANGE ROD	Fitting	41
	Removal	40
GEAR CONTROL QUADRANT	Fitting	39
	Removal	39
PIVOT LEVER ROD	Fitting	41
	Removal	40
REVERSE INTERLOCK	Adjustment	43
	Fitting	42
	Removal	41
ROTOR DOG CLUTCH	Adjustment	43
ROTOR CONTROL ROD	Fitting	38
	Removal	38

SERVICE BULLETINS APPERTAINING TO THIS SECTION ARE:

<i>Bulletin No.</i>	<i>Date</i>

TOOLS LIST

<i>No.</i>	<i>off</i>
2	1/4" BSW Open ended spanners
1	5/16" BSW Open ended spanner
2	3/8" BSW Open ended spanners
1	Pair 6" engineers pliers
1	Small punch
1	Copper/Rawhide mallet
1	1 lb-Ball pein hammer

Section D

Unless otherwise stated, all the illustration numbers in this section refer to diagram "D1", which can be found at the end of this section on page 44.

DIFFERENTIAL CONTROL

To remove the differential control rod (417)

Remove the nut (421) and washer (422) from the eye bolt (420) on the end of the control rod, and withdraw the eye bolt from its location.

Remove the split pin (418) from the rotor control rod block, and hence remove the rod complete with the eye bolt and springs.

To remove the differential control arm (423)

Remove the differential control rod, then proceed as follows: remove the split pin (425) from the quadrant pin (424), which acts as the pivot pin for the control arm, and hence remove the pin and the control quadrant.

To fit the differential control arm (423)

Position the differential lock selector quadrant over the differential lock trunnion (426).

Slide the quadrant pin (424) through the main frame and into the quadrant such that the split pin (425) may be inserted through the quadrant pin between the main frame and the top of the quadrant.

To fit the differential control rod (417)

Position the rod through the locating block on the rotor control rod, and secure in position using split pin (418).

Position the eye bolt (420) in the differential lock selector quadrant and secure using the flat washer and nut (421).

NOTE: The securing nut should be fully tightened and then slackened back approx. half a turn such that the eye bolt is able to rotate under operational conditions.

ADJUSTMENTS SHOULD BE MADE AS DESCRIBED AT THE END OF THIS SECTION.

ROTOR CONTROL

To remove the rotor control rod (410)

Remove the split pin (418) from the differential lock selector control rod. Withdraw the rod from the block and move aside.

Remove the nut (413) from the eye bolt (412) and hence remove the eye bolt from the rotor control arm (414).

Remove the split pin (409) from the hand lever end of the rotor control rod (410) and then remove the rod.

To fit the rotor control rod (410)

Position the eye bolt (412) through the rotor control arm (414) and secure using nut (413).

NOTE: The securing nut should be fully tightened and then slackened back approx. half a turn, such that the eye bolt is free to rotate under operational conditions.

Locate the top of the rotor control rod in the hand control lever (406), and secure using split pin (418).

CONTROL HAND LEVER

To remove the hand control lever (406)

Remove the split pin (409) from the rotor control rod (410), and move the rod clear.

Remove the philidas locknut (408) and spring (407), and then remove the hand lever from the gear control quadrant (405).

To fit the hand control lever (406)

Position the control lever over the threaded shaft on the gear control quadrant (405).

Fit the spring (407) and nut (408) and tighten such that the spring holds the hand lever securely in the notches in the gear quadrant.

Fit the rotor control rod (410) to the hand lever, and secure using split pin (409).

ADJUSTMENTS SHOULD BE MADE AS DESCRIBED AT THE END OF THIS SECTION

GEAR CONTROL QUADRANT

To remove the gear control quadrant (405)

Remove the philidas locknut (408) and spring (407) from the hand control lever, and move the lever aside.

Remove nut (399) and setscrew (398) and remove the handlebar positioning arm (397).

Remove the split pin (404) from the positioning pin (401). Remove the positioning pin and spring (402).

Remove the 2-setscrews which secure the control quadrant to the main frame.

NOTE: These setscrews also secure the depth control skid socket.

To fit the gear control quadrant (405)

Position the control quadrant on the main frame with the lug facing forward, and secure using the 2-setscrews which also retain the depth skid socket.

Position spring (402) inside the quadrant and slide the positioning pin (401) through the quadrant and spring, and secure using split pin (404).

Locate the positioning arm (397) over the positioning pin (401) and secure the arm to the quadrant using setscrew (398), washer (400) and philidas locknut (399).

NOTE: The philidas locknut should be fully tightened and then slackened back approx. half a turn, such that the positioning arm is free to move.

Locate the control hand lever (406) over the shaft on the gear control quadrant, fit spring (407) and nut (408), and tighten such that the spring holds the hand lever securely in the notches in the gear quadrant.

ADJUSTMENTS SHOULD BE MADE AS DESCRIBED AT THE END OF THIS SECTION.

Section D

CLUTCH CONTROL

To remove the pivot lever to control arm rod (440)

Remove the nut (443) from the eye bolt (442) on the clutch control arm (445), and then remove the eye bolt.

Remove the split pin (439) from the control arm rod (440) at the pivot lever end.

To fit the pivot lever to control arm rod (440)

Locate the end of the rod through the pivot lever (436) and pivot lever rod (434), and secure using the flat washer and split pin.

Position the eye bolt (442) through the control arm (445) and secure using nut (443).

NOTE: The philidas locknut should be fully tightened and then slackened back approx. half a turn, such that the eye bolt is free to rotate under operational conditions.

To remove the hand lever to pivot lever rod (434)

Remove the split pin (439) from the control arm rod (440) at the pivot lever (436), and move the control arm rod aside.

Remove the split pin (431) from the hand lever pivot pin (430), and remove the pivot pin and rod.

To fit the hand lever to pivot lever rod (434)

Locate the control arm rod (440) through the pivot lever (436) and position the pivot lever rod over the control arm rod, and secure using the flat washer and split pin.

Position the adjusting link (432) between the lugs of the hand lever, and secure using the pivot pin (430) and split pin (431).

To remove the control arm (445)

Remove the locknut (443) from the control rod eye bolt (442) and move the eye bolt and rod aside.

Slacken the setscrew (447) which secures the control arm to the clutch operating pawl, and remove the control arm and locating key (446).

To fit the control arm (445)

Position the control arm and locating key on the clutch operating pawl spindle and secure by tightening setscrew (447).

Locate the control rod eye bolt (442) through the top of the control arm and secure using locknut (443).

NOTE: The philidas locknut (443) should be fully tightened, and then slackened back approx. half a turn, such that the eye bolt is free to rotate under operational conditions.

To remove the hand lever (428)

Remove the split pin (431) and pivot pin (430) from the adjusting link (432), and move the pivot lever rod aside.

With the aid of a punch, remove the flat headed rivet (429) from the hand lever, and then remove the lever. A new rivet (429) will be required when refitting the hand lever.

To fit the hand lever (428)

Position the hand lever on the handlebar, locate using the flat headed rivet (429) (inserted from the left hand side of the handle bar) and burr the end of the rivet into the countersunk in the lever.

Position the adjusting link (432) between the lugs of the hand lever, and secure using the pivot pin (430) and split pin (431).

ADJUSTMENTS SHOULD BE MADE AS DESCRIBED AT THE END OF THIS SECTION.

GEAR CHANGE CONTROL

To remove the gear lever and gate

Remove the 2-bolts which secure the gate (380) to the main frame, and remove complete with the upper gear lever. Do not lose the gear lever spring (378).

Remove the nut (388) from the 3rd and reverse gear control rod eye bolt (387).

Remove the pivot bolt (381), and remove the lower gear lever.

To fit the gear lever and gate

Locate the control rod eye bolt (387) through the gear lever and secure using the nut (388).

Secure the gear lever to the flange on the 1st-2nd gear control tube using the pivot bolt (381) and nut (383).

Position the upper gear lever through the gate (380), and with the spring (378) located correctly in the upper lever, position over the lower lever and secure the gate using the 2-bolts through the rear support bracket (384) and into the main frame.

To remove the gear control tube (389) and rod (390)

Remove the gear lever, rear bracket (384) and stay rod (373), then proceed as follows:

Slacken the retaining setscrews on the 3rd and reverse gear selector arm (396) and using a screwdriver blade, lever the selector arm from its location.

NOTE: Retain the locating key (394) and the brass universal joint (395).

Slacken the retaining setscrew on the 1st-2nd gear selector arm (392) and using a screwdriver blade, lever the selector arm from its location.

NOTE: Retain the locating key (394) and the brass universal joint (391).

The control tube and the rod can now be removed.

To fit the gear control tube and rod

Locate the rear bracket (384) and gate (380) against the main frame and secure using the 2-bolts and nuts.

Section D

Locate the control rod and tube through the main frame and secure to the rear bracket by inserting the threaded trunnion through the bracket and secure using the flat washer and nut (385).

Position the upper gear lever (370) through the gate, and with the spring (378) in position in the upper lever, position the two halves of the gear lever together and checking that the control rod eye bolt (387) locates through the lower lever, secure to the flange on the control tube (389) using the pivot bolt (381), washer and nut (383). Fit and tighten the eye bolt nut (388).

NOTE: The nut (388) should be fully tightened, then slackened back approx. half a turn such that the eye bolt is free to rotate under operational conditions.

Check that the brass universal joint (391) slides freely on the 1st-2nd gear selector arm (392) and on the control tube. If not, the location holes should be reamed out as necessary to produce free movement. Locate the selector arm through the universal joint and position the control tube through the other hole. Position the selector arm over the gearbox selector shaft, and locating on key (394), tap the selector arm onto the shaft, and tighten the selector arm setscrew (393).

Fit the stay rod (373) between the main frame and the rear bracket, and adjust its length using the 2-locknuts (374) such that there is approx. $\frac{3}{32}$ free movement between the end of the control tube (389) and the main frame.

Check that the brass universal joint (395) slides freely on the 3rd-reverse gear selector arm (396) and on the control rod (390). If not, the location holes should be reamed out as necessary to produce free movement. Locate the selector arm through the universal joint and position the control rod through the other location hole. Position the selector arm over the gearbox selector shaft, and locating on key (394), tap the selector arm onto the shaft, and tighten the selector arm setscrew (393).

ADJUSTMENTS SHOULD BE MADE AS DESCRIBED AT THE END OF THIS SECTION.

REVERSE INTERLOCK MECHANISM

To remove the reverse interlock

Remove the nut and setscrew (451) from the base of the interlock vertical link (453), and remove the link.

Remove the split pins (450) from both ends of the rocker pin (449). Withdraw the rocker pin and remove the rocker (448).

Remove the nut (457) and flat washer from the rod (454), and remove the spring, flat washer and rod.

To fit the reverse interlock

Position the rocker (448) between its location points in the main frame, such that the lever part locates under the reverse gear selector arm (396). Slide the rocker pin (449) through the rocker and main frame, and secure either end using a split pin.

Secure the vertical link (453) to the rocker using the setscrew (451) and nut.

Locate the rod (454) through the main frame and twist such that it locates in the vertical link. Position a flat washer (455), spring (456) and flat washer (455) over the rod, and secure using the locknut (457).

ADJUSTMENTS SHOULD BE MADE AS DESCRIBED AT THE END OF THIS SECTION.

ADJUSTMENTS

Clutch adjustment

The clutch should be adjusted to give $\frac{3}{16}$ " - $\frac{1}{4}$ " (5-6 mm) free movement at the clutch operating arm (445). Adjustments should be taken up at the control arm, by means of the wing nut (444).

NOTE: If the clutch slips during operation, the control rod wing nut should be UNSCREWED. If the clutch does not disengage properly, the wing nut should be screwed further onto the rod. Final adjustment should be checked with the machine under operational conditions, and further adjustment made as necessary.

Gear selector control adjustment

The speed change and reverse selectors located in the gearbox, should have approx. $\frac{1}{32}$ " free movement up and down. This may be achieved by adding washers (C1-31) between the selector bush and the selector, to decrease movement, or by adding shim (C1-38) between the selector bush and the top of the gearbox case to increase free movement.

Check that the brass universal joint blocks slide freely on the selector arms and the control rod/tube. If tight, ream as necessary to provide a close sliding fit. If loose, replace the joint blocks.

Check that the 3rd-reverse gear control rod (D1-390) is free to move inside the 1st-2nd gear control tube (D1-389), if not, free and lubricate.

Support the machine such that the wheels are clear of the ground, and secure the engine clutch in the disengaged position.

To adjust 1st-2nd gear controls: while turning over the gearbox internals, by means of the starting handle, adjust to give neutral at the mid gate position by bending the control tube rod, (if necessary). Check that 1st-2nd gears are obtainable, and that they engage fully.

To adjust 3rd-reverse gear control: while turning over the gearbox internals, by means of the starting handle, adjust to give neutral at the mid gate position by screwing in or out the control rod (D1-390). Check that 3rd-reverse gears are obtainable, and that they engage fully.

Check that the selector arm interlocks are not bent, and that they function correctly, i.e. that two gears cannot be selected at the same time.

Check that the selector arm securing setscrews are tight, then lower the machine to the ground and release the engine clutch.

To adjust the reverse interlock: Lift the clutch hand lever and select reverse gear. The interlock vertical link should rise and prevent the hand lever from returning to the engaged position. (If the vertical link is worn, replace). Press down on the hand lever and check that the clutch engages: adjust the length of the spring (456) as necessary, by means of the locknut (457).

Lift the hand lever and return the gear lever to the neutral position.

Rotor dog clutch adjustment

Remove the split pin (418) from the differential control rod (417), and move the rod aside.

Adjust the effective length of control rod (410), by means of the locknut (413), such that the dog clutch is fully engaged when the hand lever (406) is moved to the "in" position. Check that the dog clutch disengages completely when the hand lever is moved to the "out" position.

Section D

Position the differential lock control rod (417) through the block on the rotor control rod, and secure using a split pin.

Differential lock adjustment

Support the machine such that the wheels are clear of the ground, and secure the engine clutch in the disengaged position.

Check for obstructions (dirt, stones etc.) behind the differential lock quadrant otherwise the movement of the differential lock selector will be restricted.

Position the hand lever (406) in the "out" position, select 1st gear, and while turning over the gearbox internals by means of the starting handle, adjust the effective length of control rod (417) using locknut (421) on the end of the rod. Additional adjustment is provided by the locknuts (427) and trunnion (426) on the differential lock selector.

Move the hand lever to the "in" position and check that the differential lock engages fully.

Move the hand lever to the "out" position, checking that the differential lock and rotor dog clutch are completely disengaged. Move the gear lever to the neutral position and release the engine clutch.

Final adjustments should be made under operational conditions.

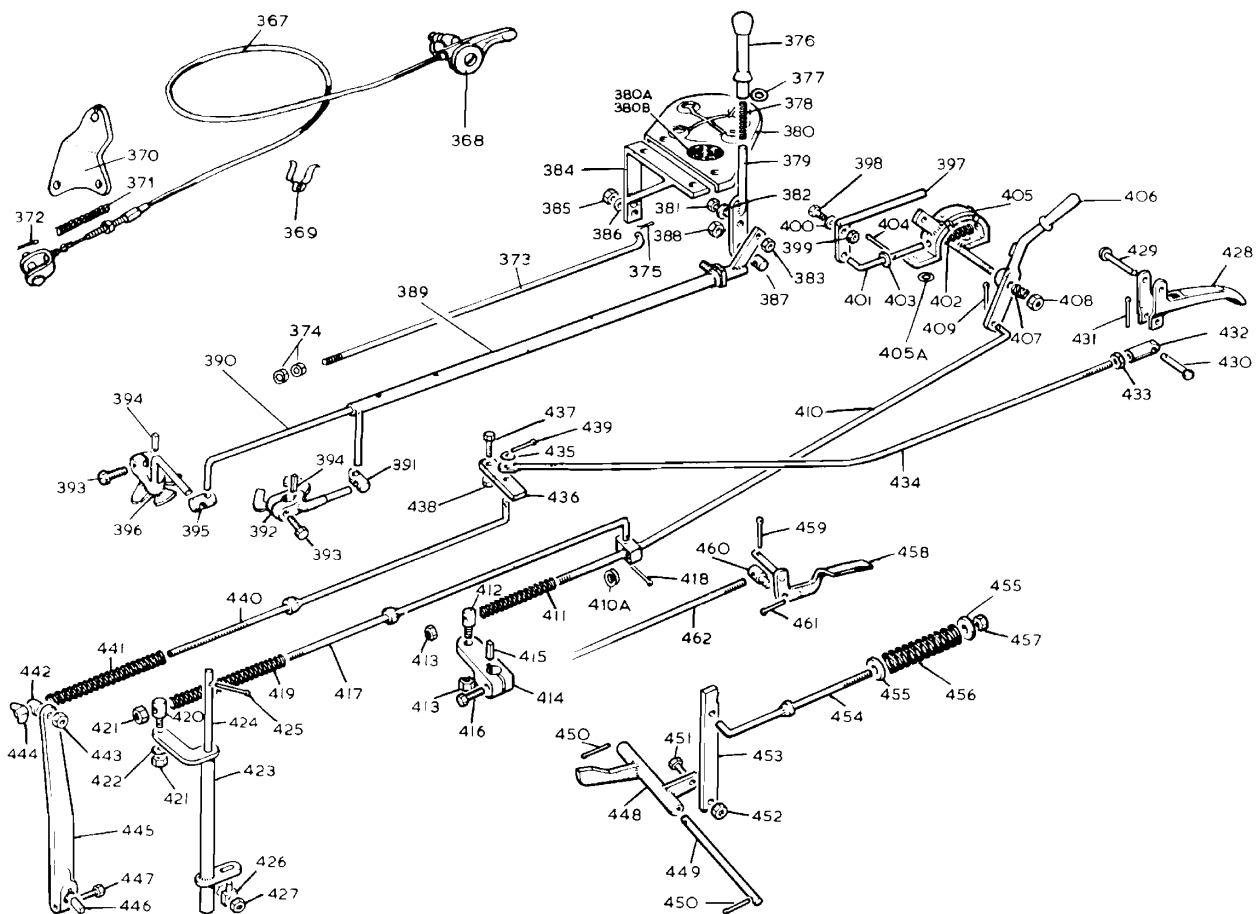

Illustration 'D1'
CONTROLS ASSEMBLY
Keep this page open when referring to the instructions in section "D"

CONTENTS

<i>Subject</i>	<i>Action</i>	<i>Page</i>
DEPTH CONTROL WHEEL	Assemble	46
	Dismantle	46
FRONT SHIELD	Fitting	49
	Removal	46
MAIN FRAME	Assemble	48
	Dismantle	47
	Fitting	48
REAR SHIELD	Removal	47
	Fitting	49
	Removal	46
TRAILING BOARD	Fitting	46
	Removal	46

SERVICE BULLETINS APPERTAINING TO THIS SECTION ARE:

<i>Bulletin No.</i>	<i>Date</i>

TOOLS LIST *No. off*

- 1 ¼" BSW Open ended spanner
- 1 ¼" BSW Ring spanner
- 1 5/16" BSW Open ended spanner
- 1 5/16" BSW Ring spanner
- 1 3/8" BSW Ring spanner
- 1 ½" BSW Ring spanner
- 1 9/16" BSW Ring spanner
- 1 11/16" BSW Ring spanner
- 1 ¾" AF Ring spanner
- 1 Cold chisel
- 1 Small punch
- 1 Copper/Rawhide mallet
- 1 1lb. Ball pein hammer
- 1 Pair 6" engineers pliers
- 1 Medium screwdriver

SPECIAL EQUIPMENT

- Sampson C.110 glue
- Container/tray
- Self grip wrench
- 2ft. long straight edge

Section E

All illustration numbers in this section refer to illustration "E4" on page 50 unless otherwise stated.

TO REMOVE THE REAR SHIELD (325)

1. Support the rear of the machine such that the rotor assembly and depth control skid are well clear of the ground, then proceed as follows:
 - 1a. Remove the depth control skid (279) or depth control wheel (where fitted), by releasing the spring clip (281) and moving the depth control arm (280) to the right, allowing the skid to slide out of the socket (278).
 - 1b. Remove the locknuts (331), spring and flat washers from the clamping bolts (328) each side of the rear shield, and remove the bolts.
 - 1c. Remove the setscrew (326) and spring washer (327) from each side of the rear shield pivot tube.
 - 1d. Remove the shield by lifting upwards and sliding back over the rotor.

Trailing board (337)

The trailing board is easily removed from the rear shield by removing the locknuts (333) from the hinge bar (332) and withdrawing the bar. Fitting the trailing board is the reverse to the removal procedure.

Depth control wheel – to dismantle

Remove the wheel cap (353) and release and remove the locknut (345) from the tab washer (346). Slide the wheel assembly from its location in the arm (342). Remove the outer dust cover (347) and withdraw the axle. Remove the wheel bush (348) and inner dust cover (349).

Depth control wheel – to assemble

Position the wheel bush (348) through the inner dust cover (349) and locate through the wheel centre. Slide the axle through the bush from the opposite side to the dust cover. Fit the outer dust cover (347) and locate the axle through the arm (342). Fit the tab washer (346) and locknut (345); tighten the nut and secure by bending over the tab washer. Fit and tighten the wheel cap (353). Remove oil screw (351) and lubricate bush: replace oil screw.

To fit the rear shield – see instruction 6.

TO REMOVE THE FRONT SHIELD (324)

2. Remove the rear shield as previously described in instruction 1, then proceed as follows:
 - 2a. Remove the 3-setscrews (184) shown in illustration "E1" to the right of the chaincase oil filler plug (180), and also remove the setscrew (187) which secures the shield to the top of the backplate.
 - 2b. Remove the 5-setscrews (312), washers and nuts, from the sideframe (295).
 - 2c. Remove the rotor clutch nuts and springs.
 - 2d. Undo the tab washer which secures the rotor stub axle nut to the side frame, and remove the nut and tab washer.
 - 2e. Remove the locking wire (297) from the 2-frame bolts (296), which secure the side frame (295) to the main frame, and while supporting the rotor assembly (on blocks etc.) remove these bolts and the side frame.

Illustration 'E1'

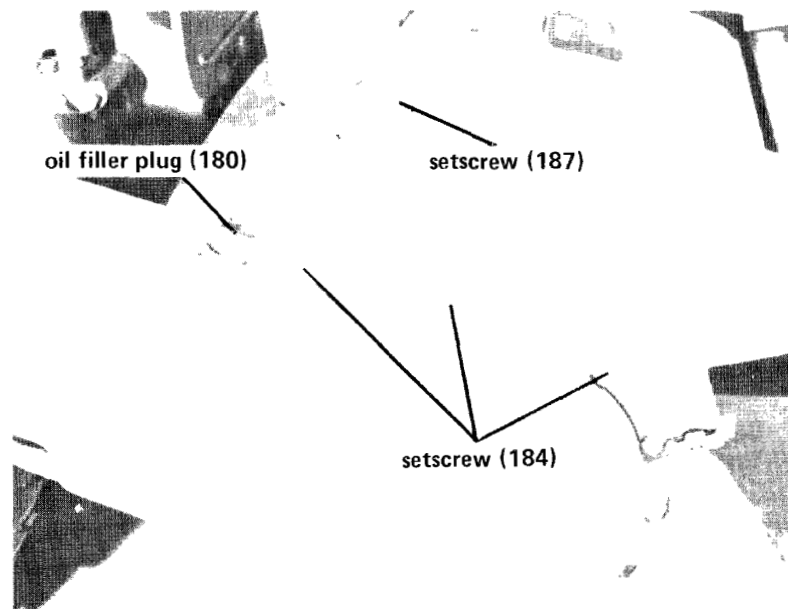

- 2f. Slide the front shield (324) as far to the right as possible, so that the rotor assembly may be withdrawn from the clutch drive plate studs, complete with the outer dust cover.
- 2g. Remove the front shield by lifting straight out from the right hand side of the machine.

To fit the front shield — see instruction 5.

TO DISMANTLE/REMOVE THE MAIN FRAME (275)

3. Remove the rear and front shields, as previously described in instructions 1. and 2., then proceed as follows:
 - 3a. Remove the engine throttle control from the machine handlebars, together with any cable clips. (On Kohler models, remove the air cleaner assembly by removing the hose and releasing the securing bolts).
 - 3b. Disconnect the clutch hand lever to pivot lever rod, shown in illustration "E2" by removing the split pin (439).

Illustration 'E2'

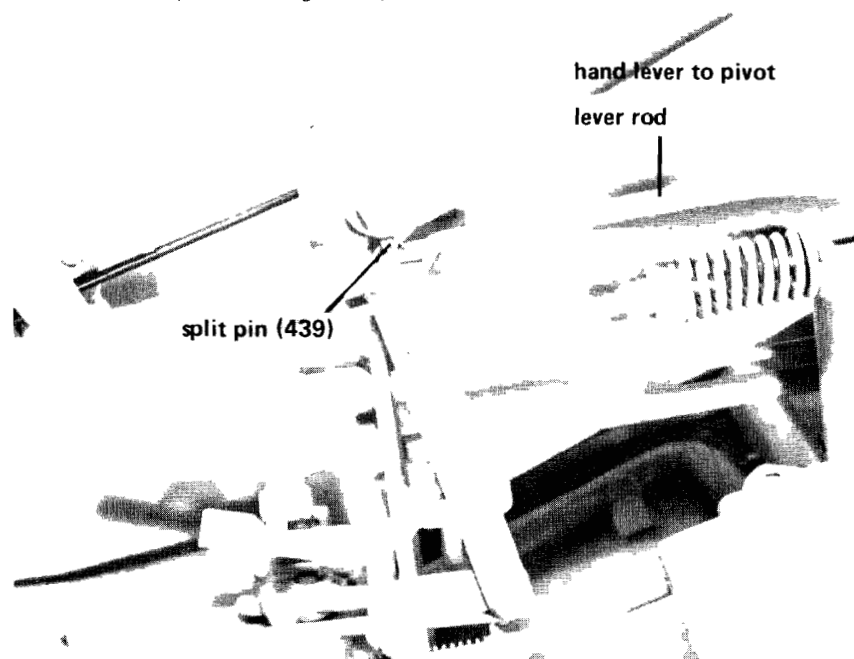

Section E

- 3c. Remove the gear control rods and selector gate, rotor control and differential lock quadrant, gear selector interlock mechanism, and the clutch rods as described in Section "D".
- 3d. Remove the depth skid socket (278), by removing the 2-bolts (291) which secure the socket support stays to the main stay tube (304).
- 3e. Remove the split pin (272) and special nut (271) from the handlebar pivot block, and bolts (264) from the handlebar slide (263), and remove the handlebars.
- 3f. Disconnect the fuel line from the fuel tank and empty tank (on Hatz model, remove the small injector pump spill pipe from the top of the tank). Remove the nuts (362) and washers (361) from the "U" bolts (360) and remove these "U" bolts and the fuel tank.
- 3g. Remove the tool box (273), starting handle (305) and depth control arm (280).
- 3h. Remove the chain tensioner adjusting screw and the special frame bolt behind it. Also remove the bolts which secure the jackshaft housing to the gearbox case, and the frame bolt from the top of the backplate, so that the backplate assembly may be removed complete.
- 3j. Remove the locking wire from the main frame to gearbox bolts (316), and remove these bolts, and the bolts (315) which secure the frame to the front of the gearbox. The main frame can now be removed.

TO FIT/ASSEMBLE THE MAIN FRAME (275)

- 4. Locate the main frame on the front of the gearbox, using the setscrews (315), but do not tighten these setscrews at this stage, otherwise the frame may become distorted making it difficult to fit the remaining frame securing setscrews.
- 4a. Locate and secure the back of the main frame using the setscrews (316). Fully tighten and lock using a 40" long piece of 16 swg wire. The front setscrews (315) can now be fully tightened.
- 4b. Fit the backplate assembly complete, using the 4-jackshaft housing to gearbox case securing bolts, and the frame bolt at the top of the backplate. Lock the frame and jackshaft housing bolts using 16 swg wire. Fit the special frame bolt, located on the bottom edge of the chaincase, then fit the chain tensioner adjusting screw.

NOTE: The chain tension should be adjusted as described at the end of Section "F".

- 4c. Fit the tool box (273), starting handle (305) and depth control arm (280).
- 4d. Fit the handlebars (261) and secure using the special nut (271) and split pin. Fit and tighten the handlebar slide bolts (264).
- 4e. Locate the depth skid socket (278) and secure the support stays to the main frame staytube using the setscrews (291) and nuts (293).
- 4f. Fit the gear control rods and selector gate, rotor control and differential lock quadrant, gear selector interlock mechanism and clutch rods, as described in section "D".
- 4g. Fit and secure the engine throttle control and cable clips (on Kohler models, fit the air cleaner assembly).

- 4h. Locate the fuel tank and secure using the "U" bolts (360) spring washers and nuts. Connect the fuel pipe and fill the tank with fuel.

NOTE: On Hatz models, fit the injector pump spill pipe and bleed the fuel system as described in the engine manufacturers handbook.

NEXT: Fit the front shield as described in instruction 5.

TO FIT THE FRONT SHIELD (324)

5. Position the front shield over the rotor clutch and loosely secure in this position, using the 3-setscrews (E1-184) and setscrew (E1-187), but do not tighten at this stage, as the shield may distort making it difficult to fit the remaining securing setscrews.
- 5a. Slide the rotor assembly, complete with the outer dust cover, onto the rotor drive plate studs, as shown in diagram "E3" and support in this position (on blocks etc.).

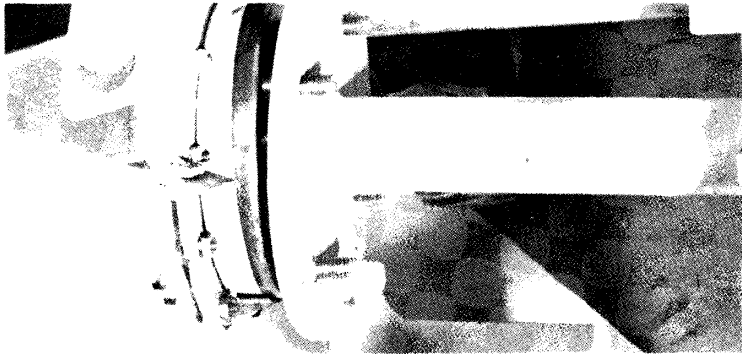

NOTE: The slot in the dust cover should be at the bottom.

- 5b. Locate the side frame (295) over the rotor stub axle, and secure to the main frame, using the 2-frame bolts (296). Fully tighten the frame bolts and secure using 16 swg locking wire.
- 5c. Fit and tighten the 5-setscrews (312) which secure the front shields to the side frame. Fully tighten the 3-chaincase setscrews (E1-184) and backplate setscrew (E1-187)
- 5d. Fit the rotor stub axle tab washer and nut. Tighten the nut fully and secure by bending over the tab washer.
- 5e. Fit the springs and nuts to the rotor clutch drive plate studs, and adjust the clutch as described at the end of Section "F".

NEXT: Fit the rear shield as described in instruction 6.

TO FIT THE REAR SHIELD (325)

6. Position the rear shield such that the depth control socket (278) locates through the slot in the top of the shield. Hook the shield over the channel on the rear of the front shield and secure using setscrew (326) and washer (327) at each end of the shield pivot.
- 6a. Fit the shield clamping bolts (328) and secure using the flat washer (329) spring washer (330) and locknut (331).
- 6b. Position the depth control skid (279) or wheel arm (341) in the control socket (278), locating the peg of the depth control arm (280) through the skid, and secure in position using the spring clip (281).

Section E

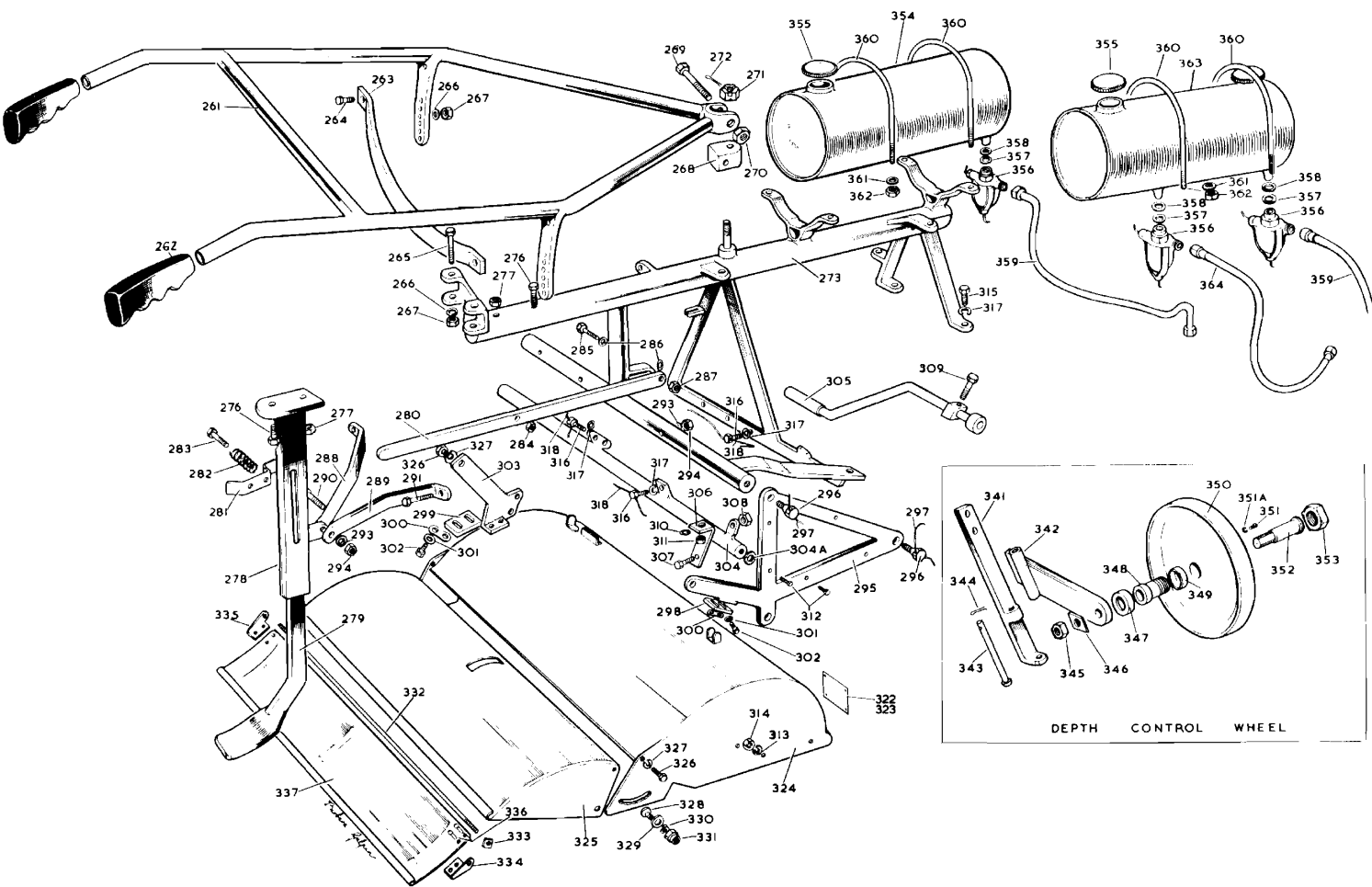

Illustration 'E4'
Main frame, shields and handlebars

Keep this page open when referring
to section "E"

CONTENTS

<i>Subject</i>	<i>Action</i>	<i>Page</i>
BACKPLATE	Assemble	57
	Dismantle	55
	Fitting	57
	Removal	55
CHAIN	Adjustment	60
CHAIN TENSIONER	Fitting	59
	Removal	54
CHAIN CASE	Fitting	59
	Removal	54
JACKSHAFT	Fitting	57
	Removal	57
JACKSHAFT SPROCKET	Fitting	58
	Removal	54
ROTOR ASSEMBLY	Fitting	59
	Removal	52
ROTOR CLUTCH	Adjustment	60
	Assemble	58
	Dismantle	54
	Fitting	58
	Removal	54
ROTOR DRIVE SHAFT		
SPROCKET	Fitting	57
	Removal	56
ROTOR STUB AXLE	Fitting	53
	Removal	53

SERVICE BULLETINS APPERTAINING TO THIS SECTION ARE:

<i>Bulletin No.</i>	<i>Date</i>

TOOLS LIST

- | <i>No. off</i> | |
|----------------|------------------------------|
| 1 | 1/4" BSW Open ended spanner |
| 1 | 1/4" BSW Ring spanner |
| 1 | 5/16" BSW Open ended spanner |
| 1 | 3/8" BSW Ring spanner |
| 1 | 1/2" BSW Ring spanner |
| 1 | 9/16" BSW Ring spanner |
| 1 | 5/8" BSW Ring spanner |
| 1 | 3/4" BSW Ring spanner |
| 1 | Cold chisel |
| 1 | Copper/Rawhide mallet |
| 1 | Pair 6" engineers pliers |
| 1 | Medium screwdriver |

Section F

BLADES

If blades are to be replaced, check that the new blades are of the correct form, i.e. left or right handed. On the centre flange(s), the blades should be fitted to the left hand side, with the bolt heads against the blade shank, and the spring washers and nuts against the flange. The end blades should be fitted on the inside of the flanges using the special bolts (F7-219) with the spring washers and nuts against the blade shank. For further information on blades, see "blade maintenance" Section "G".

TO REMOVE THE ROTOR ASSEMBLY (refer to illustration "F7" on page 60 unless otherwise stated.)

1. Support the rear of the machine clear of the ground so that the rear shield may be fully raised, and the depth skid removed. Then proceed as follows:
 - 1a. Remove the nuts (215) and springs (214) from the rotor drive plate studs.
 - 1b. Undo the locking tab (230) and remove the nut (231) from the rotor stub axle.
 - 1c. Remove the locking wire from the 2-frame bolts shown in illustration "F1", and remove the 5-setscrews (F1-312) spring washers and nuts which secure the sideframe to the front shield. Remove the bolt (F1-326) which secures the sideframe to the rear shield.

Illustration 'F1'

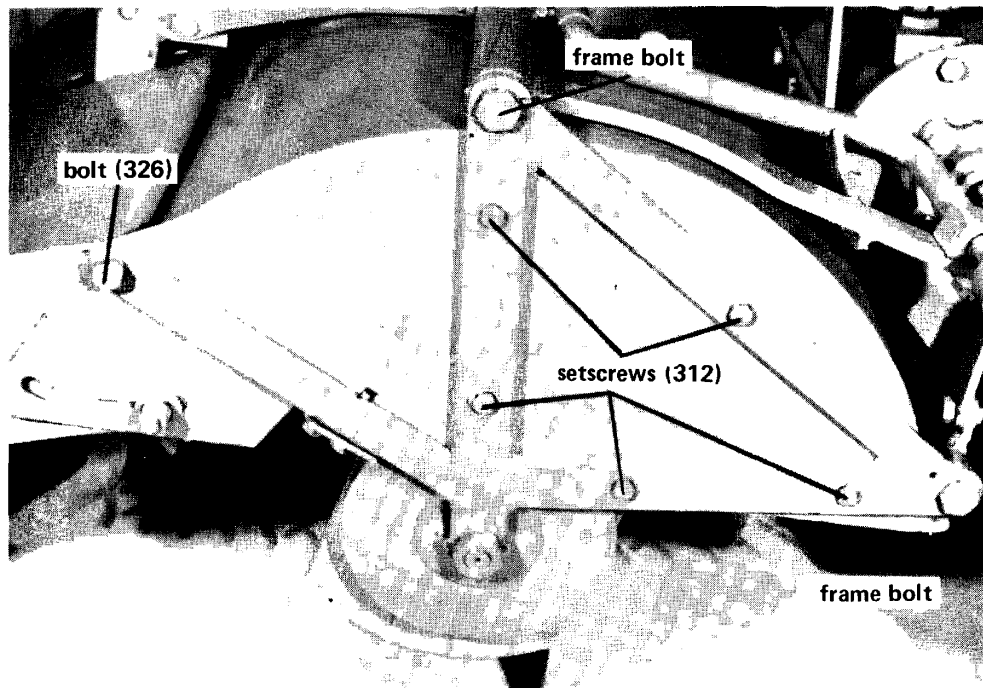

- 1d. While supporting the rotor assembly (on blocks etc.), remove the 2-frame bolts and the sideframe.
- 1e. Turn the rotor assembly such that the right hand end blades are parallel with the bottom edge of the front shield, and slide the rotor as far to the right as possible so that it may be removed from the clutch drive plate studs, complete with the dust cover (237).

Rotor stub axle – to remove

Remove the outer dust cover (237) and unscrew the round bearing cap (228) which has a left hand thread. With the aid of a special puller S.4 (see special tools Section "A"), and the rotor stub axle nut. remove the stub axle as shown in illustration "F2".

Illustration 'F2'

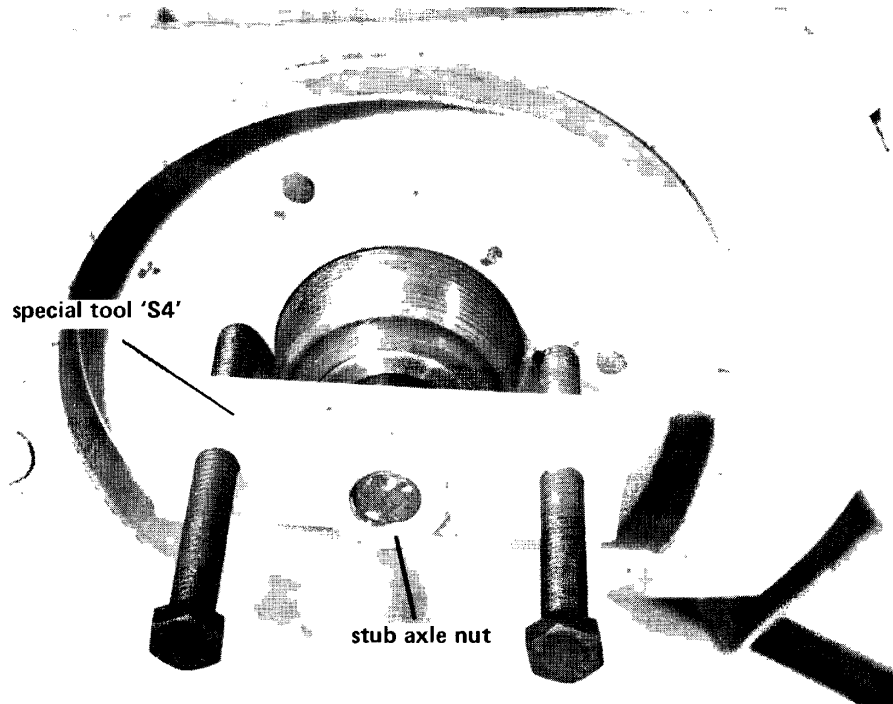

If the special puller cannot be used due to breakage of the rotor stub axle, remove the oilscrew (232) from inside the right hand rotor end flange, and using a long bar of 1" dia, inserted through the rotor centre tube, tap the stub axle from its location.

If the bearing (224) is to be replaced, the stub axle may be pressed from the bearing using a workshop press. The axle may then be pressed into a new bearing.

The oilseal (226) can be removed from its holder (225) with the aid of a $1\frac{3}{16}$ " dia. drift and a workshop press. The new oilseal should then be pressed into the holder until flush with the edge.

Rotor stub axle – to fit

Position the back plug (236), hollow side outermost, in the end of the rotor tube such that the threaded hole in the plug is in line with the oil screw hole on the inside of the rotor end flange. Using a 1" dia. drift, tap the plug into the rotor tube until the threaded hole in the plug is directly below the oil screw hole. Fit and tighten the oilscrew (232). Using a soft headed hammer tap the stub axle and bearing into their location in the rotor centre tube. Position spacer (227) through the oilseal (226) and fit the assembly over the stub axle and into the rotor centre tube (flat side of the seal outermost).

Fit a new fibre washer (229) to the bearing cap (228), then fit and tighten the cap. Remove the oilscrew (232) and lubricate the stub axle with a few strokes from an oil can: replace and tighten the screw.

To fit the rotor assembly – see instruction 9.

Section F

TO REMOVE/DISMANTLE THE ROTOR CLUTCH (refer to illustration "F6" on page 60 unless otherwise stated).

2. Remove the rotor assembly as previously described in instruction "1", then proceed as follows:
 - 2a. Remove the wearing plate (212) and take out the split pin (208) from the special nut (207).
 - 2b. Remove the oil plug (180) from the chaincase, and insert a thin bladed screw driver through the oil hole and into the links of the drive chain, to prevent the rotor drive sprocket (202) from rotating while removing the special nut (207) and flat washer (206).
 - 2c. Slide the rotor disc (211) from the splines on the drive shaft, and remove the drive plate (209).

Rotor drive disc (211)

The friction discs (210) are bonded to the rotor drive disc (211) by an Amyl Acetate glue. If these friction discs are to be replaced, the old discs must be removed completely to provide a dirt and grease free surface. The glue should be applied, as specified by the manufacturer (see "special equipment" – Section "A"), to the rotor drive disc; and the friction discs positioned and clamped to it for approx. 24 hours while the glue hardens.

Alternatively the complete assembly may be obtained as a replacement.

Drive plate (209)

The studs (213) are simply screwed into the plate, and can be removed quite easily using two locknuts clamped together, or by using a self grip wrench on the unthreaded portion of the stud.

To fit/assemble the rotor clutch – see instruction 8.

TO REMOVE THE CHAINCASE (refer to illustration "F6" on page 60 unless otherwise stated).

As no drain plug is fitted to the chaincase, place a tray under the backplate to catch the oil when the cover is removed.

3. Remove the chain tensioner adjusting screw (194) and remove the special frame bolt (182).
 - 3a. Remove the wearing shoe (183), all the setscrews from around the perimeter of the chaincase, and swing the weed cutter bracket aside. The chaincase cover and gasket can now be removed from the backplate.

Chain tensioner (192)

The chain tensioner arm is simply secured by a bolt and locknut. The arm should be held as tight as possible by the nut and bolt, yet sufficiently free to move under its own weight.

To fit the chaincase – see instruction 10.

TO REMOVE THE JACKSHAFT SPROCKET (refer to illustration "F6" on page 60 unless otherwise stated).

4. Remove the chaincase as previously described in instruction "3", then proceed as follows:

- 4a. Remove the split pin (176) and special nut (175) which secure the sprocket to the jackshaft (155).

NOTE: To prevent the jackshaft from turning while removing the special nut, position a thin bar or screwdriver blade through a top and bottom chain link, as shown in illustration "F3", to prevent movement.

Illustration 'F3'

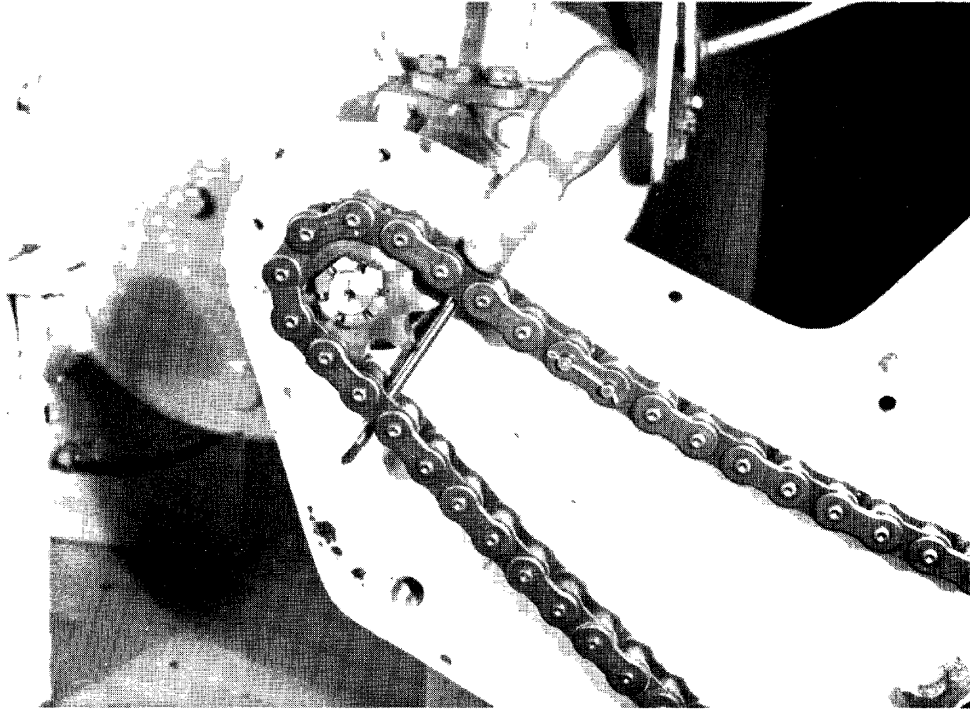

- 4b. Remove the split pin(s) from the drive chain connecting link, and using a screw driver, prise the link apart. Remove the link and chain.

Removal of the connecting link is best done near the jackshaft sprocket, so that the chain will bend sideways, allowing the link to be removed.

The jackshaft sprocket (and any shim which may be fitted) can now be removed.

To fit the jackshaft sprocket – see instruction 7.

TO REMOVE/DISMANTLE THE BACKPLATE ASSEMBLY (refer to illustration "F6" unless otherwise stated)

5. Remove the rotor assembly, rotor clutch, chaincase and jackshaft sprocket as described in instructions "1-4", then proceed as follows:
 - 5a. Remove the shield retaining setscrew from the top of the backplate, and hence remove the front and rear main shield assembly.
 - 5b. Remove the rotor dog clutch selector housing (159) by removing the 3-setscrews (160), and move the housing aside.
 - 5c. Remove the locking wire from the setscrews (163) and (164) and remove these setscrews which secure the jackshaft housing to the gearbox case.
 - 5d. Remove the locking wire from the frame bolt (190), while supporting the backplate by hand, unscrew the frame bolt and remove the backplate.

Section F

Rotor drive shaft sprocket (202) – to remove

With the aid of a workshop press, push the shaft from its location, and retain the spacer (205).

To remove the bearing (203) from the rotor drive shaft sprocket, a special tool S.5 will be required, as described in Section "A". Position the studs of the tool through the holes in the back of the drive shaft sprocket, and using a workshop press, as shown in illustration "F4", remove the bearing. The new bearing may be pressed onto the drive shaft sprocket with the aid of a 1¼" ID piece of tube.

Illustration 'F4'

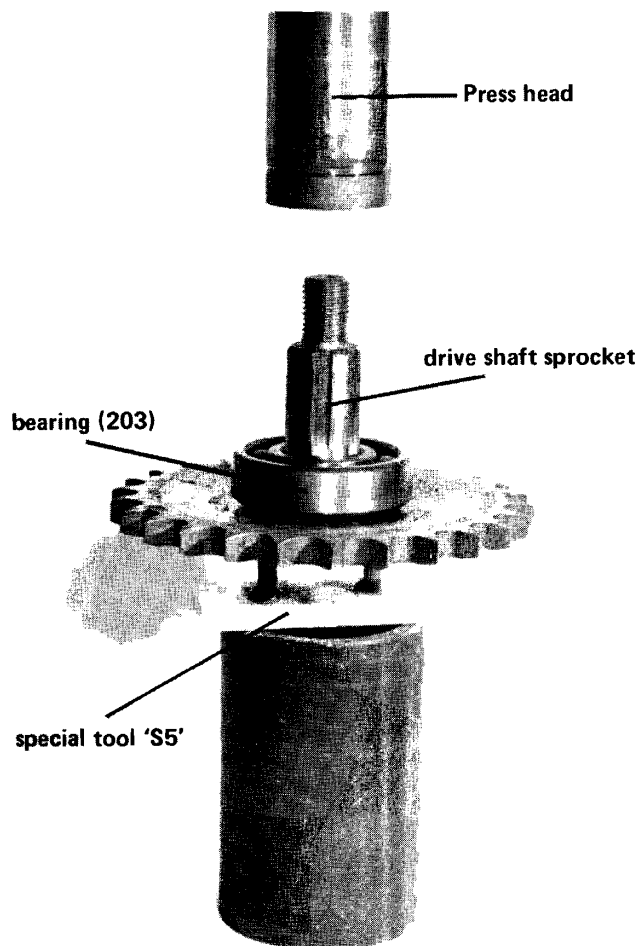

Rotor drive shaft sprocket oilseal (204) may be pressed from its location, with the aid of a 2¼" dia. drift and a workshop press. The new oilseal may be pressed into position (flat side of seal towards the rotor) until flush with the housing.

Rotor bearing housing (170) may be removed by carefully drilling out the rivets (171) using a ¼" dia. drill.

When riveting the housing to the backplate, check that the slot in the dust cover (169) is positioned at the bottom (when the backplate is in the working position). The new rivets should be inserted from the backplate side and burred over on the bearing housing. Excessive burrs should be removed using a small hand grinder, to prevent them from fouling the drive plate (209) when the rotor clutch is assembled.

Rotor drive shaft sprocket (202) – to fit

Position the rotor drive shaft sprocket and bearing against the rotor bearing housing and press into the housing.

Jackshaft (155) – to remove

The jackshaft may be pushed from the bearing (172) using a workshop press. The fixed dog (153) can be removed from the shaft by knocking out the pin, using a hammer and a small punch. When refitting the dog, the end of the new pin should be burred over into the countersunk on each side of the fixed dog, and the burrs should then be ground flat.

To remove the bearing (172) from the backplate, insert a long piece of $1\frac{3}{16}$ " dia. bar through the jackshaft housing, from the gearbox end, and using a workshop press push the bearing from its location.

The new bearing may be pressed straight into its location using a workshop press.

The jackshaft housing (167) may be removed from the backplate by carefully drilling out the rivets (171) using a $\frac{1}{4}$ " dia. drill. To ensure that the backplate to jackshaft housing location is correct, when riveting, check that the threaded holes in the jackshaft housing end flange are in line with the corresponding threaded holes in the backplate (around the housing location).

Jackshaft (155) – to fit

Position the jackshaft in the housing, and using a suitable drift and a workshop press, push the shaft through the bearing (172) until correctly located.

NEXT: Fit/assemble the backplate as described in instruction 6.

TO FIT/ASSEMBLE THE BACKPLATE (refer to illustration "F6" unless otherwise stated)

6. Check that the rotor dog clutch sliding dog (152), and a new jackshaft housing gasket (151) are in position, then proceed as follows:
 - 6a. Locate the jackshaft housing over the sliding dog and fit the frame bolt (190) which will support the weight of the backplate.
 - 6b. Fit the jackshaft housing securing bolts (163) and (164) and fully tighten these bolts and the frame bolt (190). Secure using locking wire.
 - 6c. Reposition the rotor dog clutch selector housing (159), ensuring that the selector block (156) locates correctly in the groove in the sliding dog, and secure using the 3-setscrews (160).
 - 6d. Refit the front and rear shield assembly, and secure the front shield to the top of the backplate using the setscrew (187) spring washer and nut.

NEXT: Fit the jackshaft sprocket as described in instruction 7.

Section F

TO FIT THE JACKSHAFT SPROCKET (refer to illustration "F6" on page 60 unless otherwise stated.)

7. Locate the jackshaft sprocket (172) on the jackshaft. Using a straight edge positioned across the face of the jackshaft and rotor drive shaft sprockets, as shown in illustration "F5", check that the sprockets are in line. Shim (173) should be added behind the jackshaft sprocket as necessary to produce the correct alignment. Fit the special nut (175) to the jackshaft.

Illustration 'F5'

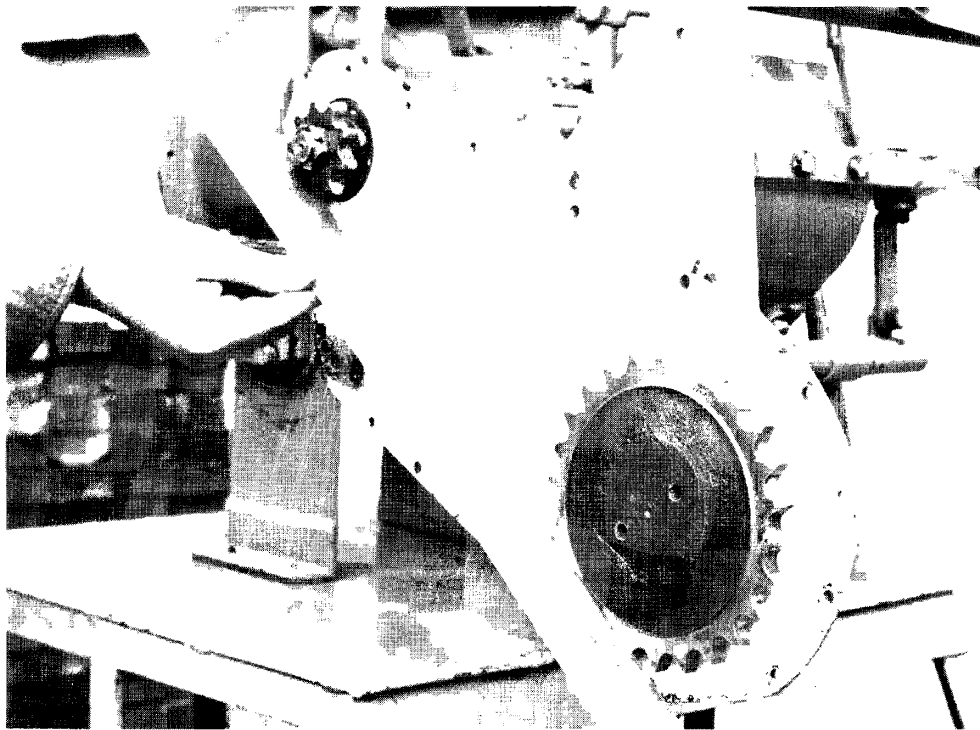

- 7a. Fit the drive chain and secure the connecting link using the split pin(s).
- 7b. Position a thin bar or screwdriver blade through the drive chain as shown in illustration "F3", to prevent the sprocket from turning while tightening the special nut (175). Secure using a split pin (176).

NOTE: If a new jackshaft has been fitted, an $\frac{1}{8}$ " dia. hole will have to be drilled through the jackshaft to accept the split pin. Ensure all "swarf" is removed from sprocket after drilling.

NEXT: Fit the rotor clutch as described in instruction 8.

TO FIT THE ROTOR CLUTCH (refer to illustration "F6" unless otherwise stated).

8. Position the spacer (205) on the rotor drive shaft sprocket and through the oilseal (204).
- 8a. Position the drive plate (209) over the rotor bearing housing and slide the rotor disc (211) onto the splines of the shaft and up to the drive plate.
- 8b. Fit the flat washer (206) and special nut (207) to the drive shaft, and with a thin bar or screwdriver blade inserted through the links of the drive chain to prevent the drive shaft sprocket from rotating, fully tighten the special nut (207) and secure using a split pin (208).

NOTE: Care should be taken, when tightening the special nut, to avoid bending the backplate.

- 8c. Fit the wearing plate (212) over the drive plate studs and slide up to the rotor disc (211).

NEXT: Fit the rotor assembly as described in instruction 9.

TO FIT THE ROTOR ASSEMBLY (refer to illustration "F7" on page 60 unless otherwise stated).

9. Position the rotor assembly such that the right hand end blades are parallel to the bottom edge of the shield, and with the slot of the dust cover (237) positioned at the bottom, slide the rotor onto the clutch drive plate studs, and support the rotor in this position (on blocks etc.).

NOTE: The side of the front shield will have to be levered out slightly to clear the dust cover when sliding the rotor onto the drive plate studs.

- 9a. Fit the sideframe over the rotor stub axle, and secure to the main frame using the 2-frame bolts shown in diagram "F1". Fully tighten these bolts and secure using 2-4" lengths of 16 swg locking wire.
- 9b. Fit and tighten the 5-setscrews (F1-312) shown in diagram "F1", together with the bolt (F1-326) which secures the sideframe to the rear shield.
- 9c. Fit the locking tab (230) and nut (231) to the rotor stub axle. Fully tighten the nut and secure by bending the tab washer over the nut.
- 9d. Fit the springs (214) and nuts (215) to the clutch drive plate studs and adjust the rotor clutch as described at the end of this section.
- 9e. Fit the depth control skid into its socket, and lower the rear of the machine.

TO FIT THE CHAINCASE (refer to illustration "F6" on page 60 unless otherwise stated)

10. Secure a new gasket to the chaincase using a smear of "Hermetite". Fit the chaincase to the backplate ensuring that the chain tensioner is positioned correctly such that the sliding block (193) will present the flat end towards the tensioner adjusting screw (194).

Secure the chaincase to the backplate using the setscrews (184), two of which also secure the chaincase to the weed cutter brackets, and four others which also secure the chaincase wearing shoe (183).

NOTE: The setscrews (184) vary in length around the perimeter of the chaincase and should be used as shown in the small inset to illustration "F6" on page 60. Setscrew "A" is $\frac{1}{4}$ " BSW x $\frac{3}{4}$ " long, setscrew "B" is $\frac{1}{4}$ " BSW x $\frac{5}{8}$ " long, setscrew "C" is $\frac{1}{4}$ " BSW x $\frac{1}{2}$ " long and setscrew "D" is $\frac{1}{4}$ " BSW x $\frac{7}{8}$ " long.

- 10a. Fit and tighten the frame bolt (182), then fit the chain tensioner adjusting screw. The drive chain tension may be adjusted as described at the end of this section.
- 10b. Fill the chaincase with $\frac{3}{8}$ pint (0.25 litres) of SAE 90 gear oil.

Section F

ADJUSTMENTS

Drive chain

The drive chain tension should be checked and adjusted so that the total up and down movement is between $\frac{3}{8}$ " (9.5 mm) and $\frac{1}{2}$ " (12.7 mm).

The tension of the chain can be checked by inserting a screwdriver through the oil filler hole, in the chaincase, and into one of the chain links. Turn the screwdriver so that the chain is gripped, and having loosened the locknut on the chain tensioner adjusting screw, adjust to give the correct movement. Screwing in of the adjusting screw will tighten the chain and vice versa. Tighten the adjusting screw locknut and recheck tension, if correct replace the chaincase oil filler plug.

Rotor clutch

For normal setting, tighten the nuts to fully compress the springs, then slacken back each nut half a turn. Final adjustment should be made under operational conditions, such that the rotor does not slip unless jammed by some obstruction.

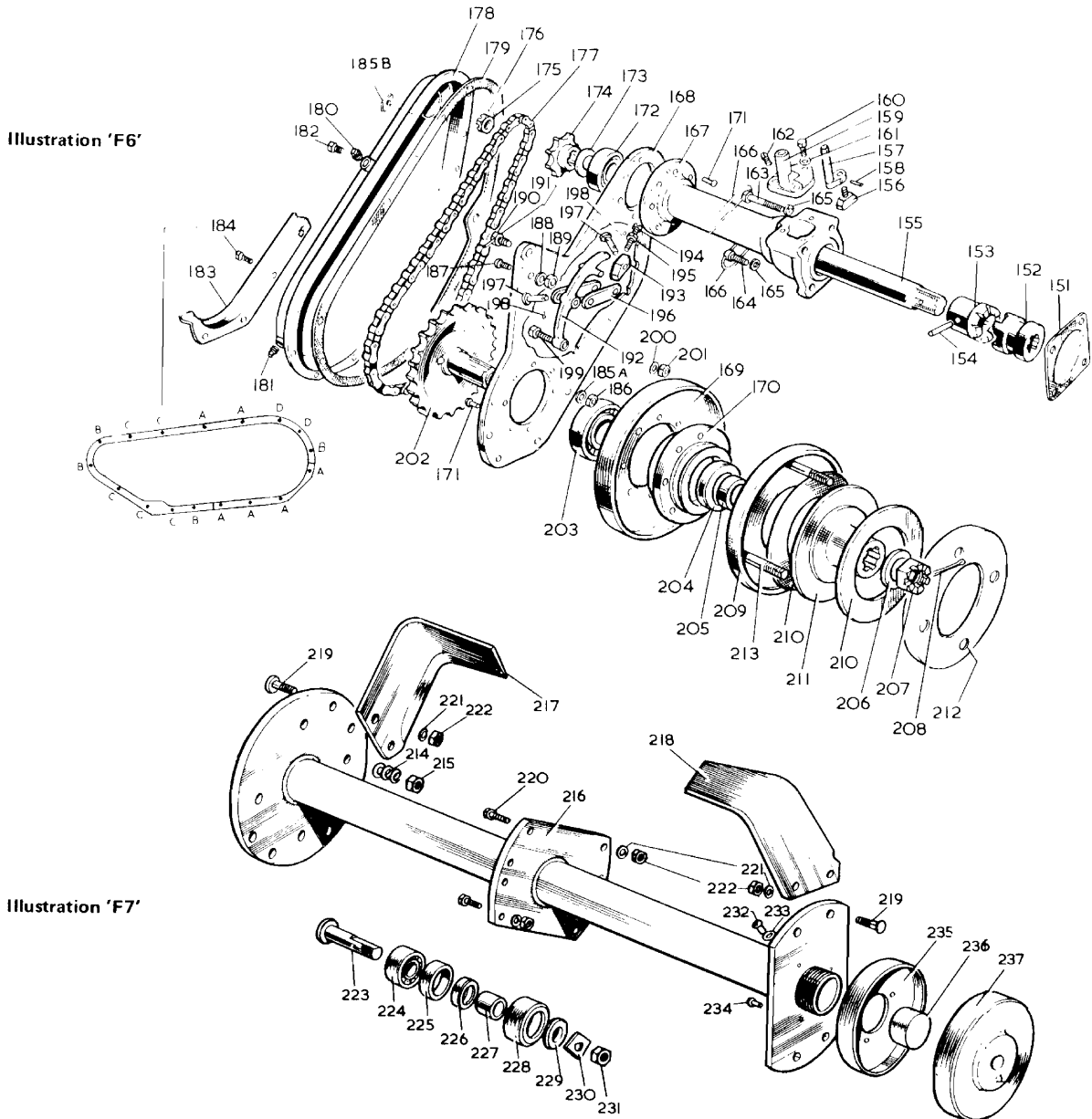

CONTENTS

Fault finding	66
Lubrication and maintenance chart	62
Maintenance	
Component	
Air cleaner	64
Blades	64
Chaincase	64
Daily	63
Gearbox	63
Monthly	63
Rotor clutch	64
Weed cutters	64
Weekly	63
Wheels	64

SERVICE BULLETINS APPERTAINING TO THIS SECTION ARE:

<i>Bulletin No.</i>	<i>Date</i>

LUBRICATION AND MAINTENANCE CHART

EVERY 25 HOURS
LUBRICATE THROTTLE CABLE, GEAR CLUTCH AND ROTOR CONTROL PIVOTS, HANDLEBAR SWIVEL AND SLIDE SHIELD HINGES, DEPTH CONTROL MECHANISM

EVERY 25 HOURS
CHECK CLUTCH (1/4" PLAY AT LEVER)
ADJUST AT CLUTCH ARM

EVERY 25 HOURS
CHECK CHAIN TENSION

EVERY 25 HOURS
CHECK GEARBOX OIL LEVEL
EVERY 250 HOURS
DRAIN AND RE-FILL GEARBOX

EVERY 10 HOURS (OR TWICE DAILY IN VERY DUSTY CONDITIONS)
CHECK AIR CLEANER OIL

EVERY 25 HOURS
CLEAN OUT SEDIMENT BOWL

EVERY 25 HOURS
OIL DOG CLUTCH

EVERY 25 HOURS
CHECK CHAIN CASE OIL LEVEL
EVERY 250 HOURS
DRAIN, WASH OUT AND RE-FILL CHAIN CASE

EVERY 10 HOURS
CHECK ENGINE OIL LEVEL
EVERY 25 HOURS
DRAIN AND RE-FILL ENGINE SUMP

EVERY 10 HOURS
WATCH FOR SIGNS OF UNDUE ROTOR CLUTCH SLIP
ADJUST IF NECESSARY

EVERY 25 HOURS
CHECK TYRE PRESSURE
(20 LBS PER SQ INCH)

EVERY 250 HOURS
CHECK HUB NUTS FOR TIGHTNESS

EVERY 25 HOURS
CHECK ALL BOLTS AND NUTS FOR TIGHTNESS

EVERY 10 HOURS
CHECK FOR BENT BLADES AND BLADE BOLT TIGHTNESS

EVERY 25 HOURS
OIL ROTOR STUB AXLE

EVERY 25 HOURS
CHECK WEED CUTTER BLADES
ADJUST IF NECESSARY

RECOMMENDED LUBRICANTS

GEARBOX AND CHAIN CASE S.A.E. 90
ROTOR DOG CLUTCH
ROTOR STUB AXLE } USE ENGINE OIL
DEPTH CONTROL WHEEL (IF FITTED)

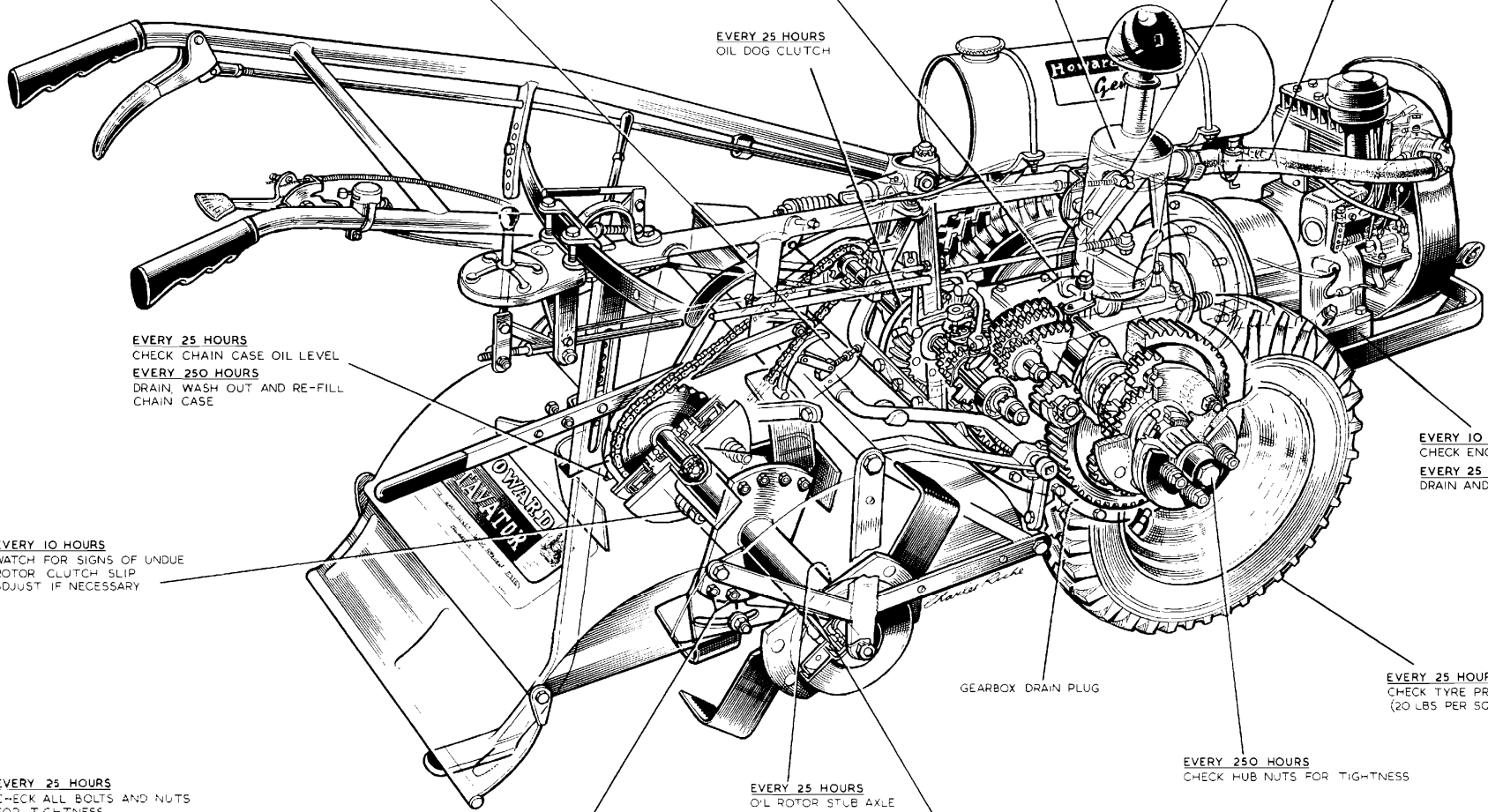

PERIODIC MAINTENANCE

Every 10 hrs. or DAILY

1. Check the engine oil level (see engine manufacturers handbook).
2. Check the level and condition of the air cleaner oil. Wash out with paraffin or kerosene, and refill with fresh oil if necessary.
3. Check the tightness of the blade bolts, and replace any bent blades.
4. Watch for signs of excessive rotor clutch slip. Adjust if necessary on the four spring loaded clutch nuts on the left hand end flange of the rotor. For normal setting, tighten the nuts to fully compress the springs, then slacken back each nut half a turn.

EVERY 25 hrs. OR WEEKLY (Additional to 10 hrs. maintenance)

1. Service the engine (see engine manufacturers handbook)
2. Check the gearbox oil level.
3. Check the chaincase oil level.
4. Check the drive chain tension (see section "F" adjustments).
5. Oil the rotor dog clutch.
6. Oil the rotor stub axle bearing.
7. Oil all the pivot points, hinges and other oiling points.
8. Check the engine clutch adjustment and reset if necessary (see section "B" adjustments).
9. Remove and clean out the sediment bowl on the fuel tank (Kohler models only).
10. Check all nuts and bolts for tightness.
11. Check tyre pressures are correct at 20 lbs/sq. in. (1.4 kg/sq. cm.)
12. Adjust the weed cutter blades (see 'rotor flange weedcutters' overleaf).

EVERY 250 hrs. or 3 MONTHLY (Additional to 10 and 25 hrs. maintenance)

1. Drain the gearbox, flush out and refill with 6 pints (3.4 litres) S.A.E. 90 gear oil (see 'cleaning the gearbox' overleaf).
2. Remove the chaincase, and wash the chain and the case with paraffin or kerosene. Replace the case and refill with $\frac{3}{8}$ pint (0.25 litres) S.A.E. 90 gear oil (see 'cleaning chaincase' overleaf).
3. Check the wheel clutch settings (see 'road wheels' overleaf).
4. Remove the air cleaner complete, and flush out with paraffin or kerosene (see 'air cleaner' overleaf).

Section G

COMPONENT MAINTENANCE

AIR CLEANER

After 250 hours work the air cleaner should be completely removed and washed out using paraffin or kerosene, including the upper half or pre-cleaner. When clean, re-assemble and fill with fresh oil up to the level mark.

CLEANING CHAINCASE

After 250 hours of work, the chaincase should be cleaned out. Remove all the bolts securing the chaincase to the backplate, allowing the chaincase oil to drain out from the joint as no drain plug is fitted. Remove the cover, ensuring that the gasket is not damaged, and wash out the inside of the case, and the drive chain using paraffin or kerosene. Re-assemble and fill with $\frac{3}{8}$ pint (.25 litres) S.A.E. 90 gear oil.

CLEANING GEARBOX

The gearbox must be cleaned out after 250 hours work.

Unscrew the drain plug on the bottom right hand inner side of the gearbox, and drain immediately after a period of running. The oil will be warm and free running, and any sediment will be held in suspension in the oil. Replace the drain plug and refill the gearbox with about 6 pints (3.4 litres) of flushing oil. Run the machine for about 3 mins. with the rotor well clear of the ground, then drain the flushing oil. Refill the gearbox with 6 pints (3.4 litres) of good quality S.A.E. 90 gear oil.

ROAD WHEELS

Each road wheel is mounted on its hub by a friction clutch device. These are adjusted so that the wheels have sufficient grip to pull the machine, but will slip if they become jammed with an obstruction between the wheels and frame

For normal adjustment, tighten each of the four nuts to fully compress the springs, then slacken back each nut half a turn.

Should the wheels appear not to be driving, check that the adjustment is correct and adjust as necessary.

ROTOR FRICTION DRIVE

The rotor, to which the blades are bolted, is driven direct from the main gearbox through a friction clutch. This clutch should only operate when the rotor blade strikes an obstacle; if the clutch appears to slip too easily, it can be adjusted by tightening the four clutch nuts to fully compress the springs, then slacken back each nut half a turn.

ROTOR FLANGE WEEDCUTTERS

Two weedcutter blades are provided, one at each side of the machine to prevent long grass or weeds binding around the rotor end flanges. These blades are slotted and secured by two setscrews each, and they should be adjusted so that they just clear the rotor flanges when the rotor is turned BY HAND. Severe power losses will occur in weedy conditions unless these blades are correctly adjusted.

MAINTENANCE OF BLADES

Only the cutting edge of the blade should rub in the soil; the backs of the blades should be clear.

The efficiency of the machine is determined largely by the condition of the blades. If they are bent or distorted through striking solid obstacles in the ground, and are not replaced, they will require greater power to drive them and the quality of work will be poor. Trouble will also arise with clogging under the shield.

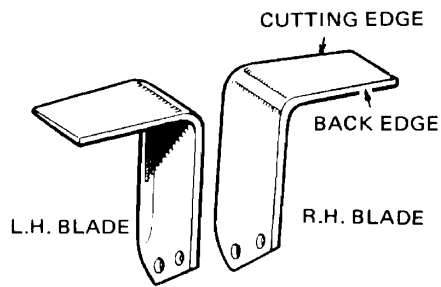
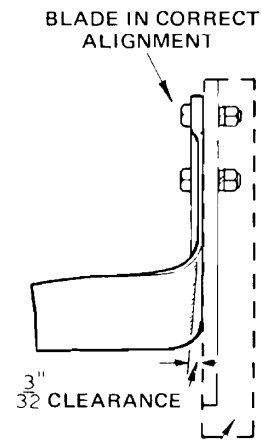
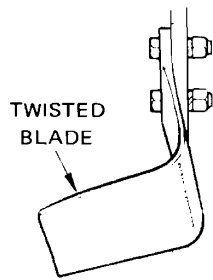

How to identify right and left-hand blades.

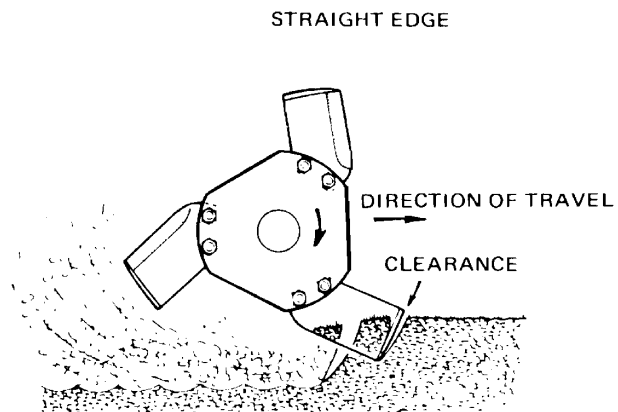

Correct blade setting showing clearance at back of blade.

Section G

MACHINE FAULT FINDING

<i>Fault</i>	<i>Possible Cause</i>	<i>Remedy</i>	<i>See Section</i>
Engine clutch slips	incorrect adjustment	adjust to correct setting	B
	worn clutch plates	adjust to compensate for wear. If all adjustment taken up and clutch still slips, replace worn parts.	B
Engine clutch does not disengage properly	incorrect adjustment	adjust to correct setting	B
	clutch control arm loose and/or worn locating key	tighten arm securing bolt and/or replace locating key	D
	engine drive adaptor bearing seized	replace with a new bearing and lubricate	B
	clutch thrust sleeve seized to shaft	free sleeve and lubricate or replace sleeve if damaged	B
Difficulty in engaging gears	incorrect engine clutch adjustment	adjust to correct setting	B
	gear selector arm interlocks bent	straighten interlocks and adjust selector arms	D
	gear selector arms loose and/or worn locating key	tighten selector arm securing bolt and/or replace locating key	D
	gear selectors too tight or too loose in the gearbox	adjust to give correct amount of free play	D
	gear selector inner control rod seized in outer tube	free and lubricate, then adjust	D
	splines on jackshaft twisted inside the gearbox	replace gearbox jackshaft	C
	worn gear selectors inside gearbox	replace internal selectors	C
	differential lock control quadrant obstructed	check for obstructions and remove if any	D
	loose hub gear cannot freely rotate	check loose hub gear bearing for wear, and replace if necessary	C
	gear selector arm to control rod joint blocks tight or worn	if tight, ream out to give sliding fit. If worn replace	D
internal gears worn	inspect gears and replace as necessary	C	

<i>Fault</i>	<i>Possible Cause</i>	<i>Remedy</i>	<i>See Section</i>
Difficulty in engaging or disengaging the differential lock	incorrectly adjusted differential lock control	adjust to correct setting	D
	differential lock selector fork seizing in gearbox	free and lubricate. If bent straighten or replace	C
Difficulty in engaging the rotor	rotor dog clutch not adjusted properly	adjust to give full engagement of the dogs	D
	rotor dog clutch operating arm loose, or locating key worn	tighten operating arm securing bolt, and/or replace the locating key	D
	rotor dog clutch selector seized in selector housing	free and lubricate, then adjust to correct setting	D
Excessive 'jumping' of machine	blades fitted wrongly	check that blades are of the correct type i.e. left or right handed	F & G
Erratic rotation of the rotor	rotor dog clutch not engaging fully	adjust to give full engagement of the dogs	D
	rotor clutch slipping	adjust to correct setting	F
	incorrect drive chain tension	adjust drive chain tension	F
Excessive blade wear	bent blades	replace	G
Clogging of the rotor	incorrectly adjusted weed cutter blades/or bent blades	adjust to correct setting/ replace bent blades	G
Machine does not move forward	wheel friction clutches incorrectly adjusted	adjust to correct setting	C



Howard Rotavator Co. Ltd.
A member of the Howard group

Saxham Bury St Edmunds
Suffolk IP28 6RP England
Telephone Bury St Edmunds (0284) 6326
Telex 8173

Directors J Austin (Chairman) P Coleclough J A Howard
W M A Conran J H D Craig S B L Fraser
F P D Moore G A Whymark A A Williams

Printed in England Copyright Howard Rotavator Co. Ltd.
October 1977 *Registered Trade Marks Form No L 779