

REFERENCE:	Nova Bus Manuals
SECTION:	08 Braking System
RS N°:	MQR 7621-350
EFFECTIVE IN PROD.:	L726-001 (2013JA30)

APPLICATION DEADLINE: 2014MA13

SUBJECT:	Front axle brake hoses and ABS sensor wiring harness (40 ft vehicles).
JUSTIFICATION:	Possible chaffing between brake hoses and surrounding components, possibly causing the loss of ABS sensor signal.

LEVEL	DESCRIPTION	DIRECT CHARGES		TIME
		LABOUR	MATERIAL	
1	Front axle: Verify the routing of the brake hoses. Front and rear axles: Verify the routing of the ABS sensor electric harness.	Nova Bus	–	10 min
2	Front axle: Replace the P-clamps and reroute the brakes hoses. Front and rear axles: Reroute the ABS sensor electric harness.	Nova Bus	Client*	45 min
				25 min

* The cost of the material will be reimbursed when claiming for this service document.

MATERIAL

QTY	PART N°	REV.	DESCRIPTION	REPLACES PART N°
LEVEL 1				
–	–	–	–	–
LEVEL 2 (only if required*)				
2 ft (609 mm)	N24590		Loom	
7	N44890		M6 Nut	
2.5 ft (762 mm)	N21078		Spiral loom	
6	N30730		Washer	
7	N44884-02		Bolt M6x25	
6	N31320-03		P-clamp	
1	N57040		Cable tie mount (high heat)	

Materials will be available within 60 days. To order, please contact Prevost Parts by phone at 1-800-771-6682, by fax at 1-888-668-2555 or by email at prevostparts.commandes@volvo.com. Specify document number, quantity of parts required and shipping address.

* The material identified in Level 2 is to be ordered only for vehicles that respect the criteria defined in Level 1.

DISPOSAL OF PARTS

REMOVED PARTS ARE:	DISCARDED *	RETAINED	* Dispose of the unused parts and the defective parts in accordance with local environmental standards in effect.
	Yes	–	

REVISION HISTORY

REV.	DATE	CHANGE DESCRIPTION	WRITTEN BY
NR	2011NO22	Initial release	Wilder Galiano
R1	2013FE15	Customer list and procedure reviewed	Wilder Galiano

APPROVED BY:

PAGE 1 OF 16

CLIENT	ORDER	ROAD NUMBER		VIN (2NVV/4RKY...)		QTY
		FROM	TO	FROM	TO	
Demo - Proto Platform 2010	L271	—	—	L82U283000001	L82U283000002	2
Airdrie Transit - Alberta	L664	—	—	L82U2B3000507	L82U2B3000507	1
Arrow Coach Line - Arkansas	L494	—	—	L82U793000397	L82U793000397	1
BC Transit - BCT - British Columbia	L463	9319	9333	L82U093000273	L82U093000287	15
BC Transit - BCT - British Columbia	L481	9334	9353	L82U794000004	L82U094000023	20
BC Transit - BCT - British Columbia	L484	9370	9403	L82U494000090	L82U494000123	34
BC Transit - BCT - British Columbia	L486	9354	9369	L82U294000024	L82U494000039	16
BC Transit - BCT - British Columbia	L487	9404	9433	L82U094000149	L82U794000178	30
BC Transit - BCT - British Columbia	L604	9434	9434	L82U5C3000597	L82U5C3000597	1
Belleville Transit - Ontario	L542	—	—	L82UXA3000088	L82U8A3000090	3
Belleville Transit - Ontario	L598	—	—	L82U5A3000581	L82U7A3000582	2
Belleville Transit - Ontario	L655	—	—	L82U3B3000385	L82U3B3000385	1
Belleville Transit - Ontario	L702	—	—	L82U4D3000706	L82U4D3000706	1
Bow Valley Transit - Alberta	L712	5	6	L82U6C3000804	L82U8C3000805	2
Brampton - Ontario	L501	0917	0921	L82U893000506	L82UX93000510	5
Brampton - Ontario	L501	0922	0926	L82U693000519	L82U893000523	5
Brantford - Ontario	L547	10101	10105	L82X6A3000082	L82X3A3000086	5
Brantford - Ontario	L663	—	—	L82U1B3000532	L82U1B3000532	1
Brantford - Ontario	L718	10123	10125	L82U5C3000826	L82U9C3000828	3
Calgary Transit - Alberta	L601	8101	8114	L82U5A4000099	L82U4A4000112	14
Calgary Transit - Alberta	L607	8115	8130	L82UXA3000477	L82U6A3000492	16
Calgary Transit - Alberta	L615	8131	8158	L82U1B4000019	L82U4B4000046	28
Calgary Transit - Alberta	L624	—	—	L82U4B4000077	L82U6B4000078	2
Calgary Transit - Alberta	L637	8161	8171	L82U7B3000356	L82UXB3000366	11
Calgary Transit - Alberta	L637	8172	8180	L82U3B3000368	L82U2B3000376	9
Calgary Transit - Alberta	L709	8181	8200	L82UXC3000806	L82U3C3000825	20
Clemson Area Transit - South Carolina (ref L722)	L641	—	—	L82U1C4500005	L82U5C4500007	3
Clemson Area Transit - South Carolina (ref L722)	L641	—	—	L82U9C4500009	L82U5C4500010	2
CMBC (TransLink) - British Columbia	L412	9401	9401	L82X993000136	L82X993000136	1
CMBC (TransLink) - British Columbia	L454	9402	9406	L82X793000359	L82X993000363	5
CMBC (TransLink) - British Columbia	L454	9407	9416	L82X893000368	L82X993000377	10
CMBC (TransLink) - British Columbia	L454	9417	9431	L82X293000382	L82X293000396	15
CMBC (TransLink) - British Columbia	L454	9432	9446	L82X893000404	L82X893000418	15
CMBC (TransLink) - British Columbia	L454	9447	9461	L82X393000424	L82X393000438	15
CMBC (TransLink) - British Columbia	L454	9462	9470	L82X093000445	L82XX93000453	9
CMBC (TransLink) - British Columbia	L455	9471	9481	L82X093000459	L82X393000469	11
CMBC (TransLink) - British Columbia	L455	9482	9491	L82X293000480	L82X993000489	10
CMBC (TransLink) - British Columbia	L482	9492	9499	L82X894000040	L82X094000047	8
CMBC (TransLink) - British Columbia	L482	9501	9517	L82X294000048	L82X094000064	17
CMBC (TransLink) - British Columbia	L483	9518	9542	L82X294000065	L82X594000089	25
CMBC (TransLink) - British Columbia	L532	9543	9551	L82U093000497	L82U693000505	9
CMBC (TransLink) - British Columbia	L533	9552	9559	L82U193000511	L82U493000518	8
CMBC (TransLink) - British Columbia	L533	9560	9573	L82U093000524	L82U093000537	14
CMBC (TransLink) - British Columbia	L534	9574	9589	L82U694000124	L82U894000139	16

CLIENT	ORDER	ROAD NUMBER		VIN (2NVY/4RKY...)		QTY
		FROM	TO	FROM	TO	
CMBC (West Vancouver) - British Columbia	L539	901	909	L82U494000140	L82U994000148	9
Demo - Engineering Platform 2010 (Altoona)	L373	373-1	373-1	L82UX83000151	L82UX83000151	1
Demo - Nova PF2010 (TARC)	L356	356-2	356-2	L82U883000231	L82U883000231	1
Demo - Plateforme 2010 (ATQ)	L456	—	—	L82U893000019	L82U893000019	1
Duke University - North Carolina (ref. L703)	L641	—	—	L82U9C4500012	L82U0C4500013	2
Duke University - North Carolina (ref. L703)	L641	—	—	L82U8C4500017	L82U1C4500022	6
Fredericton - New Brunswick	L672	—	—	L82U0B3000540	L82U2B3000541	2
Fredericton - New Brunswick	L688	8113	8113	L82U8C3000643	L82U8C3000643	1
Grand River Transit - GRT - Ontario	L464	20901	20913	L82U193000296	L82U493000308	13
Grand River Transit - GRT - Ontario	L560	21001	21009	L82U2A3000246	L82U1A3000254	9
Grand River Transit - GRT - Ontario	L599	—	—	L82X9B3000465	L82X2B3000467	3
Grand River Transit - GRT - Ontario	L631	—	—	L82X4B3000468	L82X2B3000470	3
Grand River Transit - GRT - Ontario	L633	21101	21115	L82U7B3000289	L82U8B3000303	15
Grand River Transit - GRT - Ontario	L668	21201	21220	L82U6C3000737	L82UXC3000756	20
Greater Toronto Airports Authority - GTAA - Ontario	L432	432-1	432-1	L82U793000061	L82U793000061	1
Greater Toronto Airports Authority - GTAA - Ontario	L477	L477-1	L477-1	L82U194000001	L82U194000001	1
Guelph - Ontario	L579	221	224	L82UXA3000401	L82U5A3000404	4
Guelph - Ontario	L669	—	—	L82U9B3000536	L82U4B3000539	4
Guelph - Ontario	L715	234	235	L82U3C3000792	L82U5C3000793	2
Halifax - Nova Scotia	L693	526	534	L82U8C3000657	L82U7C3000665	9
Halifax - Nova Scotia	L710	—	—	L82U7C3000780	L82U9C3000781	2
Honolulu - Hawaii	L559	201	224	L82U6A4000113	L82U7A4000136	24
Kings Transit - Kentville, Nova Scotia	L581	—	—	L82U2B3000054	L82U2B3000054	1
Lethbridge - Alberta	L489	165	169	L82U493000454	L82U193000458	5
Marketing Sales Demo - MSD 1 ISB Hybrid	L548	—	—	L82X5A3000087	L82X5A3000087	1
Moncton (Codiac) - New Brunswick	L569	—	—	L82U4B4000001	L82U4B4000001	1
Marketing Sales Demo - MSD 2	L616	—	—	L82U4C4500001	L82U4C4500001	1
Moncton (Codiac) - New Brunswick	L570	—	—	L82U6B4000002	L82U6B4000002	1
Marketing Sales Demo - MSD 5	L619	—	—	L82X7C3000367	L82X7C3000367	1
Marketing Sales Demo - MSD 6 Houston	L628	—	—	L82U8C4500003	L82UXC4500004	2
Marketing Sales Demo - MSD Hybrid	L596	—	—	L82X2B3000212	L82X2B3000212	1
Minnesota Valley Transit Authority - MVTA	L706	—	—	L82U4C4500121	L82UXC4500133	7
Moncton (Codiac) - New Brunswick	L358	358-1	358-1	L82U093000001	L82U093000001	1
Moncton (Codiac) - New Brunswick	L361	361-1	361-1	L82U293000002	L82U293000002	1
New York City Transit - New York	L608	8000	8014	L82U6B4000047	L82U0B4000061	15
New York City Transit - New York	L620	8015	8074	L82U2B4000062	L82U7B4000123	60
New York City Transit - New York	L621	8075	8089	L82U9B4000124	L82U9B4000138	15
Niagara Falls - Ontario	L499	2986	2989	L82U093000564	L82U693000567	4
Niagara Falls - Ontario	L653	—	—	L82U9C3000618	L82U9C3000621	5
Niagara Parks Commission - Ontario	L656	—	—	L82U0C3000653	L82U2C3000654	2
Peterborough - Ontario	L490	—	—	L82UX93000345	L82U593000348	4
Regina - Saskatchewan	L356	356-1	356-1	L82U883000150	L82U883000150	1
Regina - Saskatchewan	L360	—	—	L82U283000290	L82U283000290	1
Regina - Saskatchewan	L476	625	628	L82U893000313	L82U393000316	4

CLIENT	ORDER	ROAD NUMBER		VIN (2NVY/4RKY...)		QTY
		FROM	TO	FROM	TO	
Regina - Saskatchewan	L561	631	644	L82U8B4000003	L82UXB4000018	14
Regina - Saskatchewan	L639	645	654	L82U1B3000336	L82U2B3000345	10
Saskatoon - Saskatchewan	L690	1201	1204	L82U6C3000690	L82U1C3000693	4
Sault Ste-Marie Transit Services - Ontario (ref L686)	L641	135	135	L82U7C4500008	L82U7C4500008	1
Sault Ste-Marie Transit Services - Ontario (ref L686)	L641	139	139	L82U7C4500011	L82U7C4500011	1
Sault Ste-Marie Transit Services - Ontario (ref L686)	L641	136	138	L82U2C4500014	L82U6C4500016	3
St. John's - Newfoundland	L503	1066	1066	L82U4A3000071	L82U4A3000071	1
St. John's - Newfoundland	L687	1201	1209	L82U7C3000598	L82U2C3000606	9
Stratford - Ontario	L493	—	—	L82U2A3000019	L82U2A3000019	1
Stratford - Ontario	L634	—	—	L82UXB3000352	L82UXB3000352	1
Strathcona County Transit - Alberta	L523	2010	2010	L82U693000603	L82U693000603	1
Strathcona County Transit - Alberta	L524	3005	3010	L82X593000604	L82X493000609	6
Strathcona County Transit - Alberta	L580	2011	2023	L82U1A3000464	L82U8A3000476	13
Strathcona County Transit - Alberta	L659	2024	2028	L82U7B3000440	L82U4B3000444	5
Sudbury - Ontario	L465	791	795	L82U593000317	L82U793000321	5
Sudbury - Ontario	L552	801	808	L82U3A3000238	L82U0A3000245	8
Sudbury - Ontario	L632	811	817	L82U9B3000326	L82U4B3000332	7
Thunder Bay - Ontario	L488	—	—	L82U193000332	L82U593000334	3
Thunder Bay - Ontario	L614	—	—	L82UXB3000061	L82U3B3000063	3
Thunder Bay - Ontario	L662	—	—	L82U3B3000533	L82U7B3000535	3
Timmins - Ontario	L475	—	—	L82U493000311	L82U693000312	2
Timmins - Ontario	L550	—	—	L82U8A3000171	L82UXA3000172	2
Timmins - Ontario	L661	—	—	L82U9B3000486	L82U9B3000486	1
Timmins - Ontario	L720	12-98	12-98	L82U0C3000829	L82U0C3000829	1
University of Alabama - Alabama	L479	479-1	479-1	L82U394000002	L82U394000002	1
University of Alabama - Alabama	L480	480-1	480-1	L82U594000003	L82U594000003	1
University of Alabama - Alabama	L573	—	—	L82U9A4000137	L82U0A4000138	2
University of Alabama - Alabama	L640	—	—	L82U9B4000141	L82U0B4000142	2
University of Alabama - Alabama	L671	—	—	L82U5C4500119	L82U1C4500120	2
Walt Disney World - Florida	L535	1204	1213	L82UXA4000003	L82U0A4000012	10
Whitehorse - Yukon	L563	38	41	L82U3A3000255	L82U9A3000258	4
Woodstock - Ontario	L460	—	—	L82U693000309	L82U693000309	1
Woodstock - Ontario	L492	—	—	L82U4A3000040	L82U6A3000041	2

**WARNING**

Follow your internal safety procedures.

PROCEDURE

LEVEL 1: INSPECT

- 1.1. Verify the installation of the front axle brake hoses:
 - 1.1.1. Verify that P-clamps N31320-03 are installed.
 - 1.1.2. Verify that P-clamps are installed at the specified location in this document. See Figures 1 to 5.
 - 1.1.3. Ensure the brake hose position is as described in this document. See Figures 2 to 11.
 - 1.1.4. If one of the preceding conditions is not met, apply the **BRAKE HOSES** chapter of the second level of this document before proceeding to the next step of this document.
 - 1.1.5. When all the preceding conditions are met, proceed to item 1.2.

- 1.2. Verify the installation of the ABS sensor electrical harness on the front and rear axles:
 - 1.2.1. Verify that cable tie mount N57040 is installed (front axle only). See Figure 14.
 - 1.2.2. Ensure that the position of the electric harness attaching points is as described in this document. See Figures 12 to 20.
 - 1.2.3. If one of the preceding conditions is not met, apply the **ELECTRIC HARNESS** of the second level of this document.
 - 1.2.4. When all the preceding conditions are met, the vehicle may be returned to service.

LEVEL 2: INSTALL**BRAKE HOSES (FRONT AXLE ONLY)**

2.1. Raise the vehicle

**NOTE**

For information on hoisting and towing of the vehicle, see section 18: HOISTING AND TOWING in the Nova bus maintenance manual. Respect your internal safety procedures. Use appropriate hoisting equipment for your protection.

2.2. Locate the six P-clamps to replace on the front axle. See Figure 1.

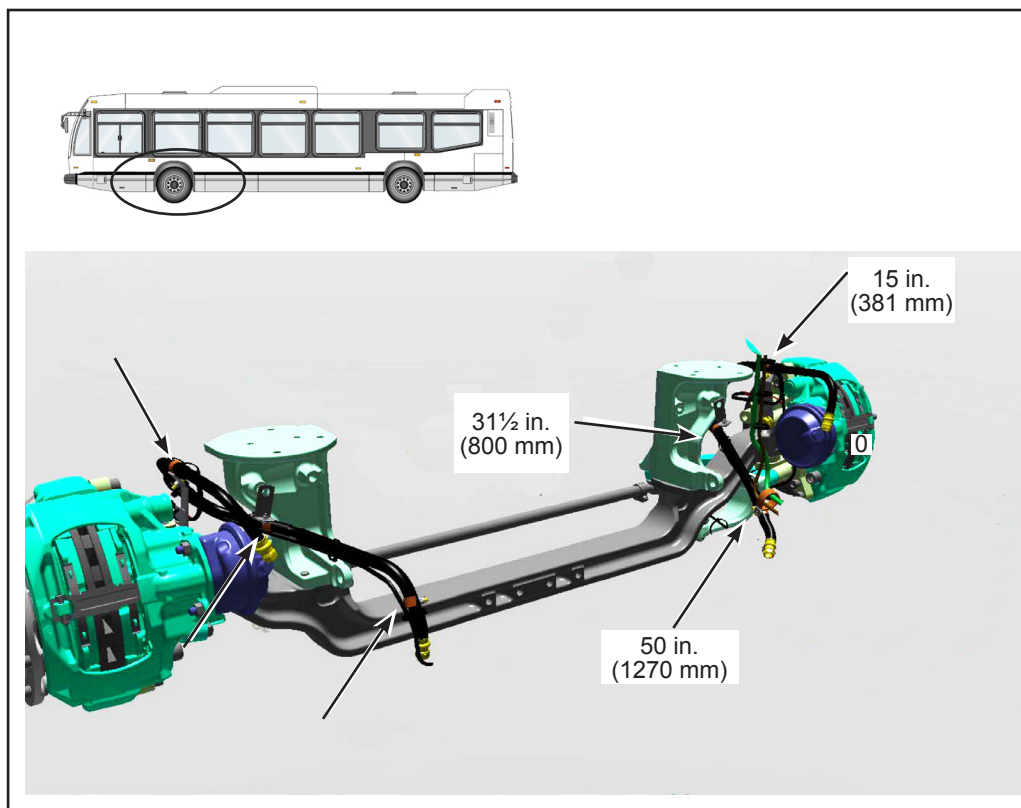

Figure 1 - Front Axle P-Clamp Location

**NOTE**

The following steps must be applied to both sides of the vehicle.

2.3. Remove the three P-clamps retaining the hose to the brake. Dispose of the P-clamps and hardware.

- 2.4. Place the brake hose fitting on the brake cylinder at an approximate angle of 35° to the vertical, toward the exterior of the vehicle. See Figure 2.

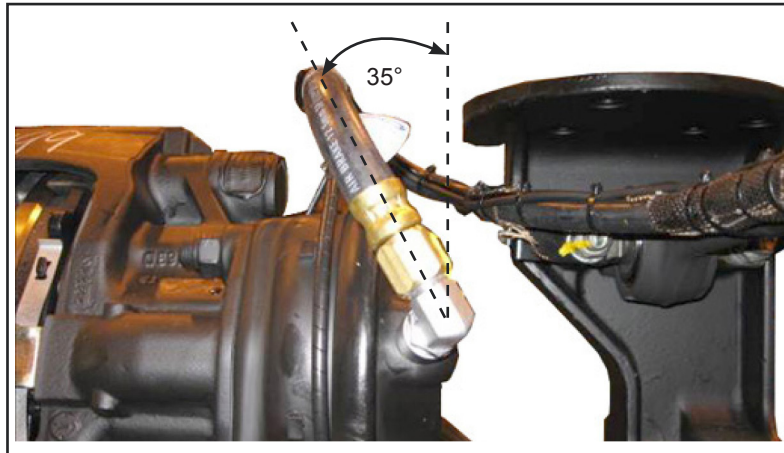

Figure 2 - 35° Brake Hose Fitting Angle

- 2.5. Mark the hose at the positions shown in Figures 3 to 5. It is suggested to place white adhesive tape around the hose.



Figure 3 - P-Clamp Location on Hose

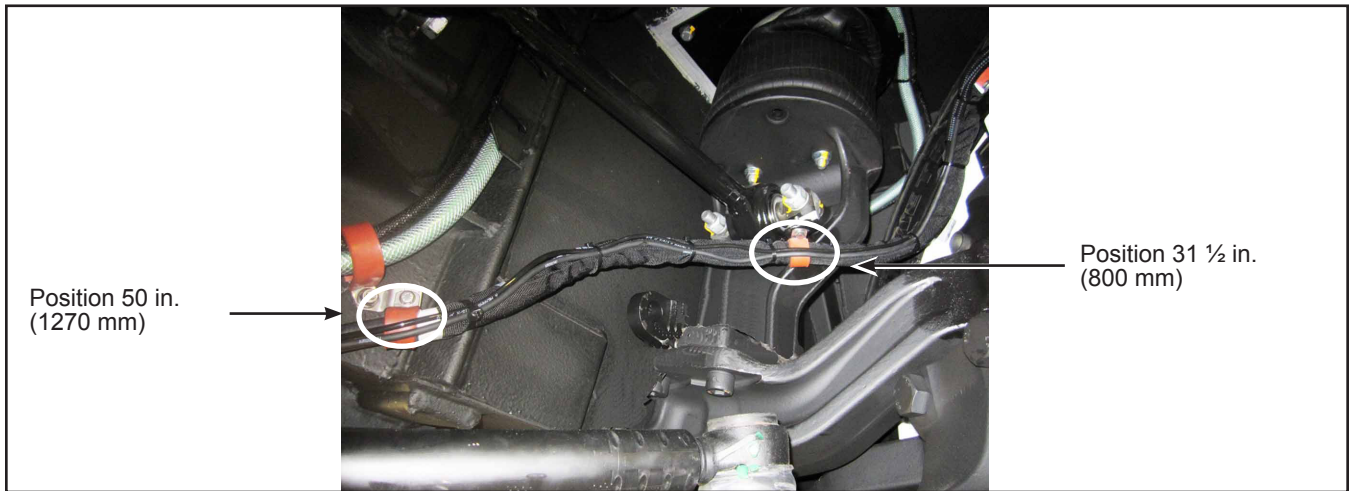

Figure 4 - P-Clamp Location on Hose

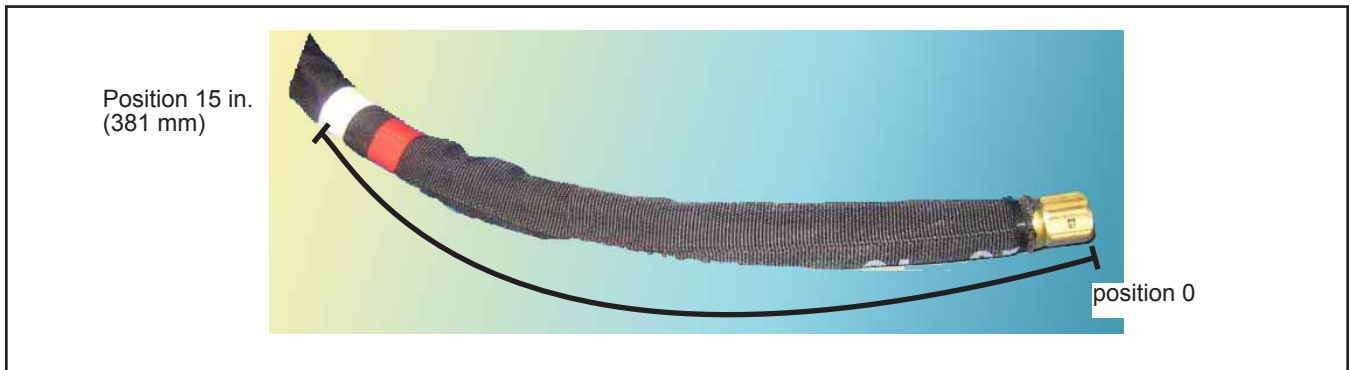

Figure 5 - Brake Hose Mark Example

2.6. Loosen the tie rod nut holding the L support. See Figure 6.

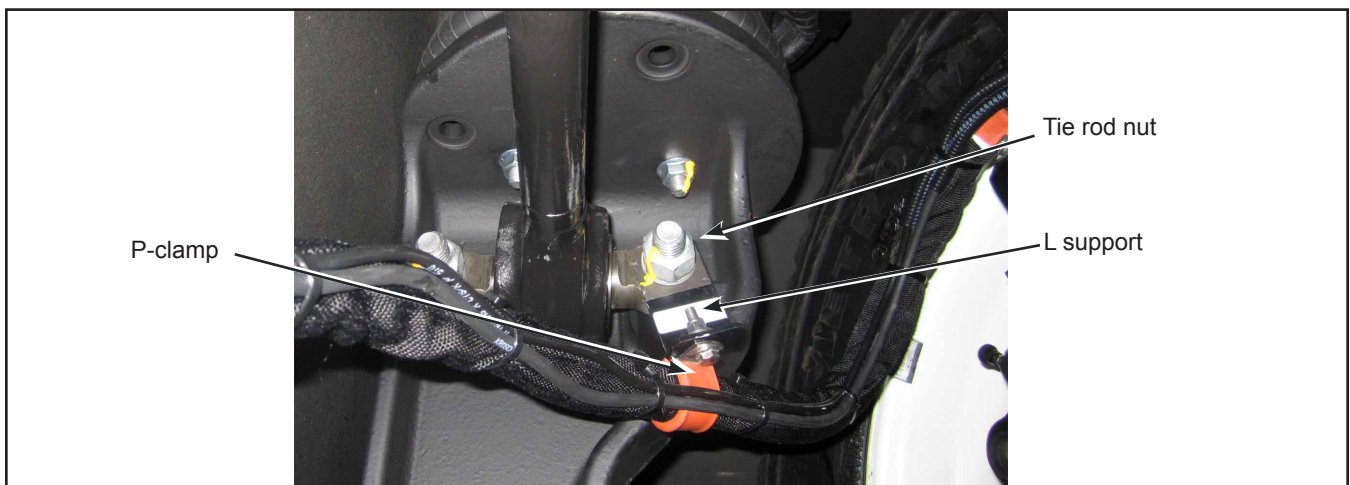

Figure 6 - P-Clamp Mounting

- 2.7. Position the L support at an approximate angle of 15° to the exterior of the vehicle. As a reference, the distance between the vertical axle wall and the L support corner should be of about 3/8 in. (9.5 mm). See Figure 7.
- 2.8. Tighten the tie rod nut holding the L support to the specified torque indicated in Figure 7.

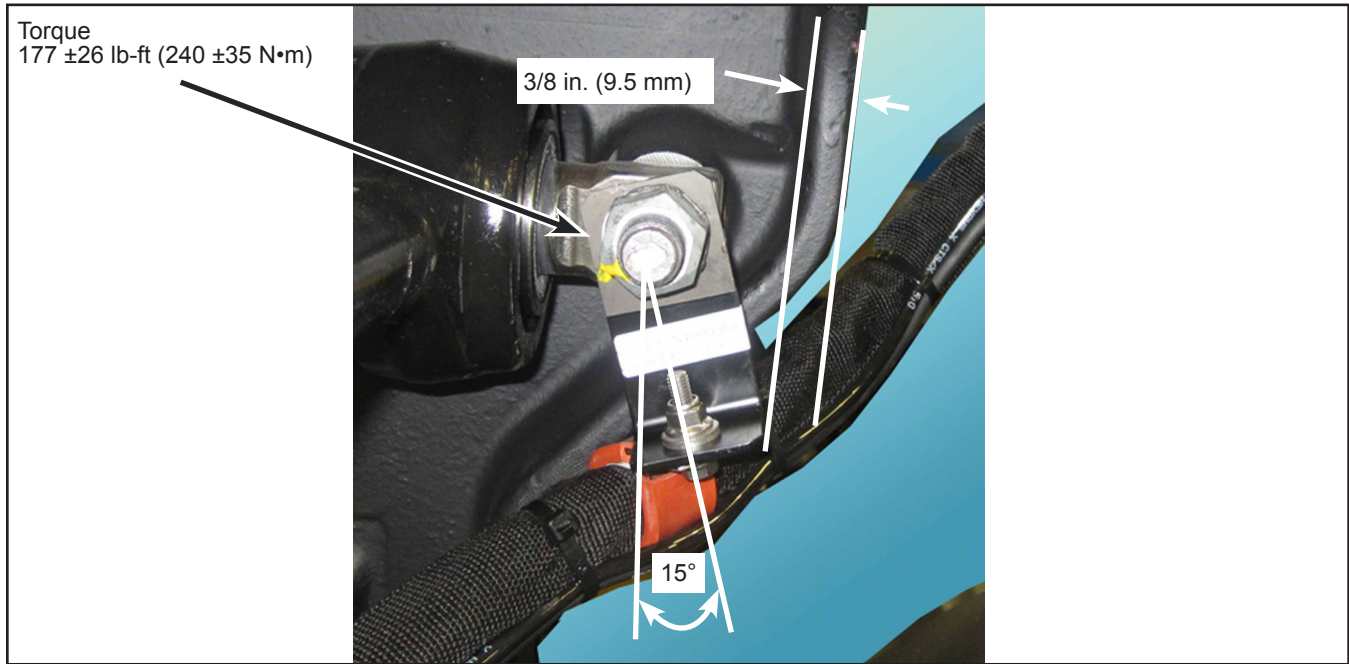

Figure 7 - L Support Position

- 2.9. Insert the three P-clamps N31320-03 around the brake hose at the positions indicated at step 2.5. Use a nut N44890, a bolt N44884-02 and a washer N30730 for the installation. See Figure 8. Do not tighten the hardware.



Figure 8 - L Support and P-Clamp Installation

- 2.10. Install a 4-in. (101 mm) length of loom N24590 between the brake hose and each P-clamp.
- 2.11. P-clamps at the 31½ in. (800 mm) and 50 in. (1270 mm) positions must be oriented so that they are on the same axis. See Figure 9.



Figure 9 - P-Clamp Alignment at the 31½ in. (800 mm) and 50 in. (1270 mm) Positions

- 2.12. Adjust the positioning of the P-clamp at the 31½ in. (800 mm) position, to obtain a minimal distance of ½ in. (12.5 mm) between the hose and the axle. See Figure 10.

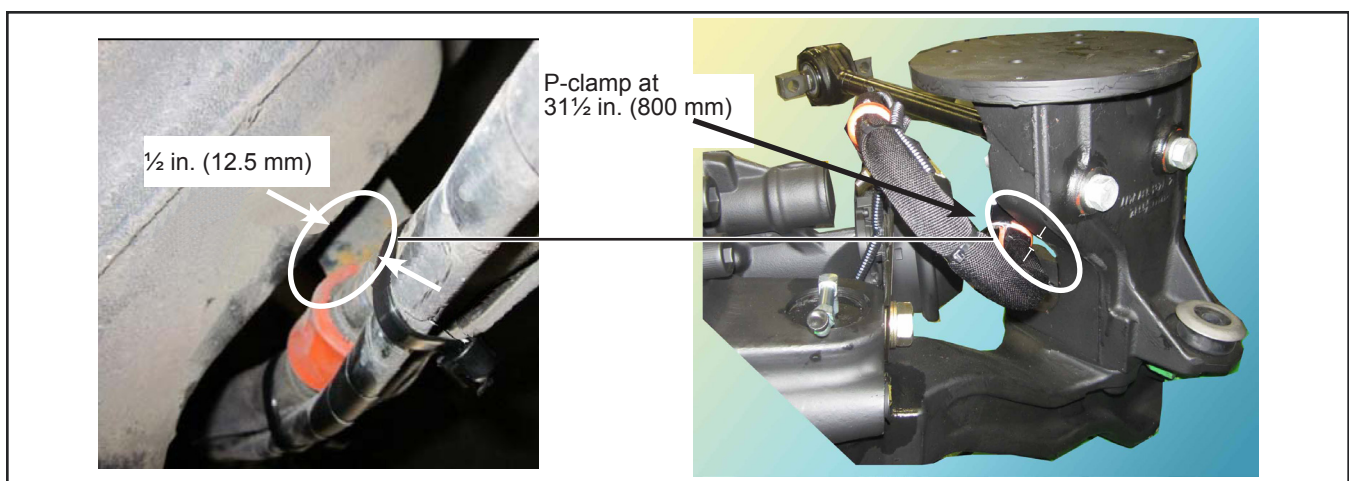

Figure 10 - Space Between the Brake Hose and the Axle

- 2.13. Adjust the positioning of the P-clamp at the 50 in. (1270 mm) position, to obtain a minimal gap of 3/8 in. (9.5 mm) between the hose and the vehicle structure. See Figure 11.

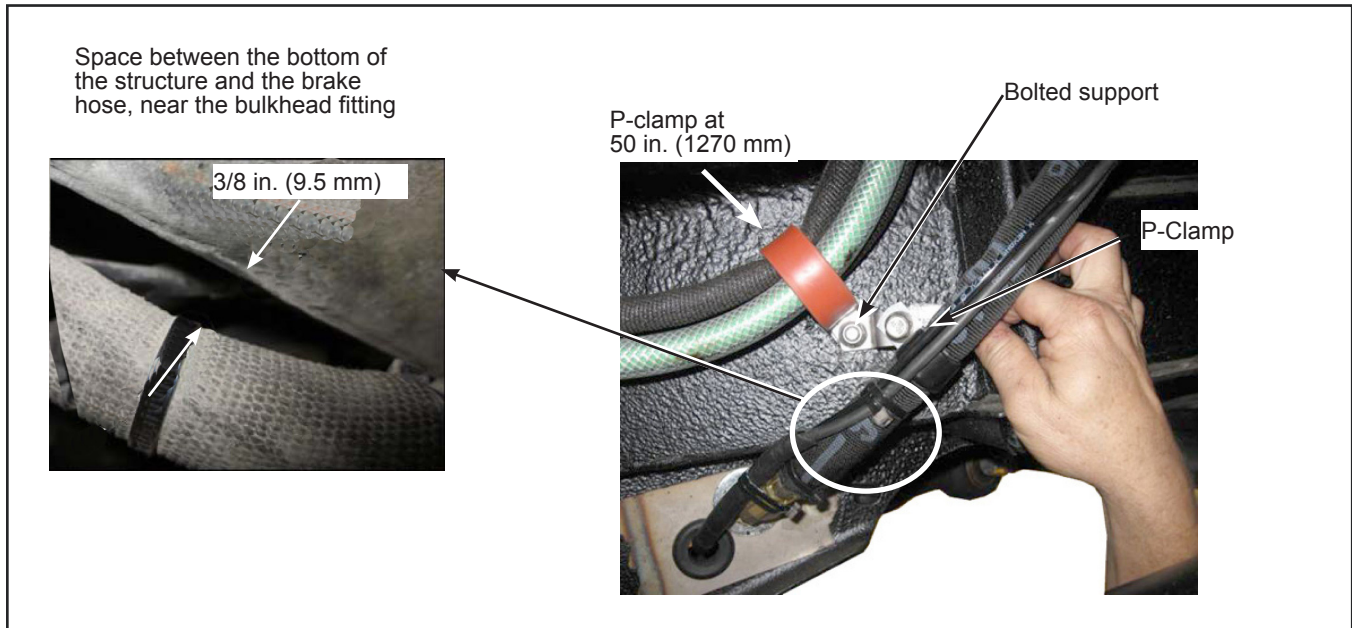

Figure 11 - P-Clamp and hose Position

- 2.14. Tighten the nut and bolt while maintaining the required positioning.

ELECTRIC HARNESS
FRONT AXLE ABS SENSOR HARNESS

 NOTE

The following steps must be applied to both sides of the vehicle.

2.15. Locate the ABS sensor electrical harness on the front axle. See Figure 12.

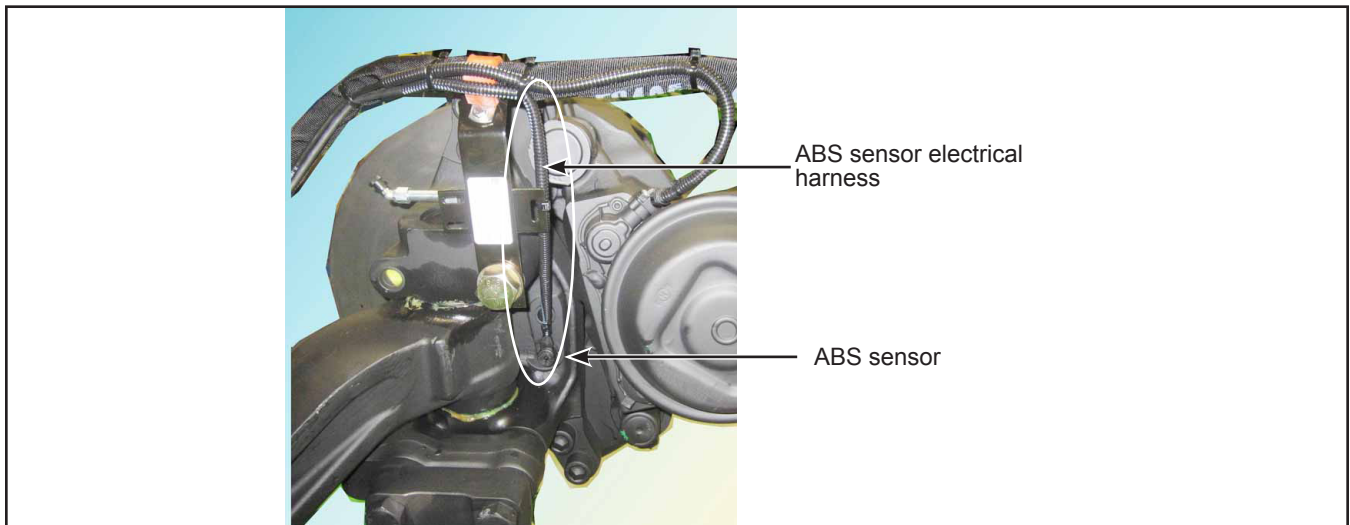

Figure 12 - ABS Sensor Electrical Harness Location

2.16. Drill a 0.20 in. (5 mm) diameter hole in the N20455-2. See Figure 13.

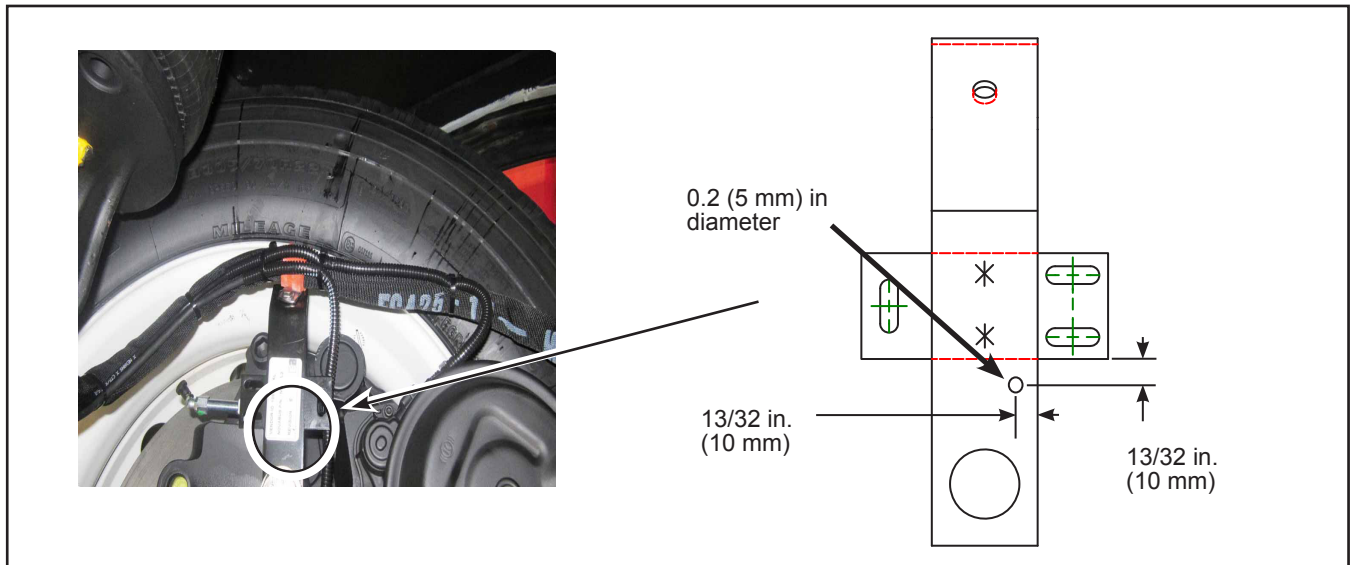

Figure 13 - Drilling of N20455-2 Support

2.17. Install the cable tie mount N57040 onto the N20455-2 support with the N44884 bolt and the N44890 nut. See Figure 14.

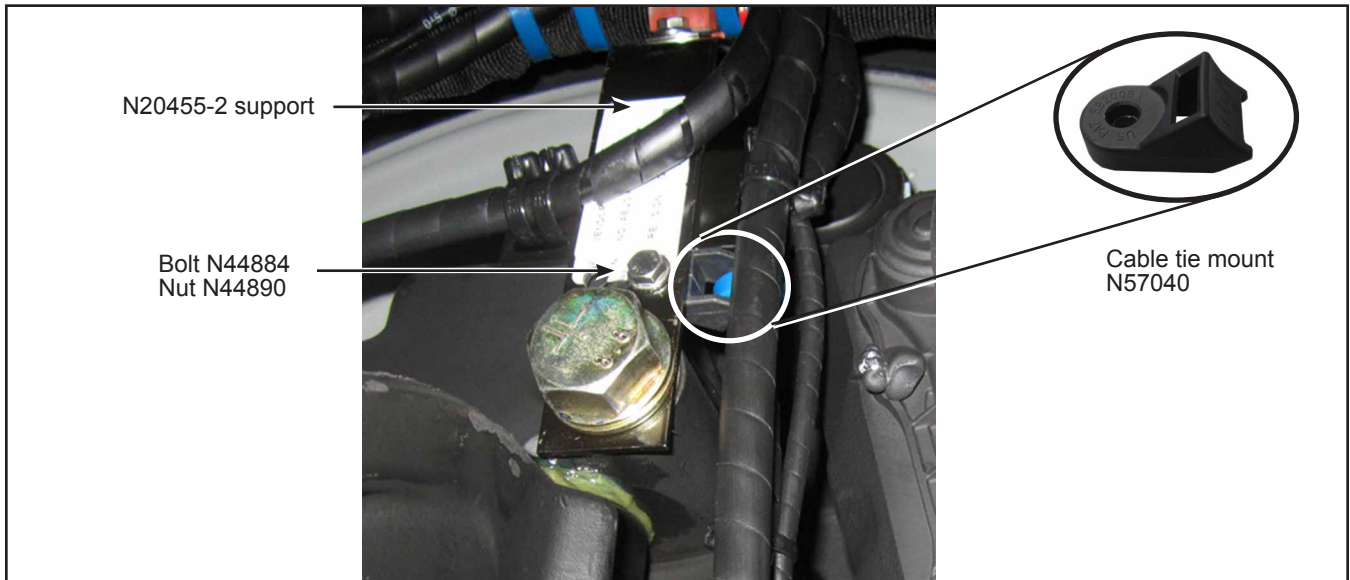

Figure 14 - CableTie Mount N57040 Installation

2.18. Install a length of protective loom N21078 onto the ABS sensor electrical harness.

2.19. Affix the electrical harness to the N57040 cable tie mount with tie-wraps at the indicated locations shown in Figure 15.

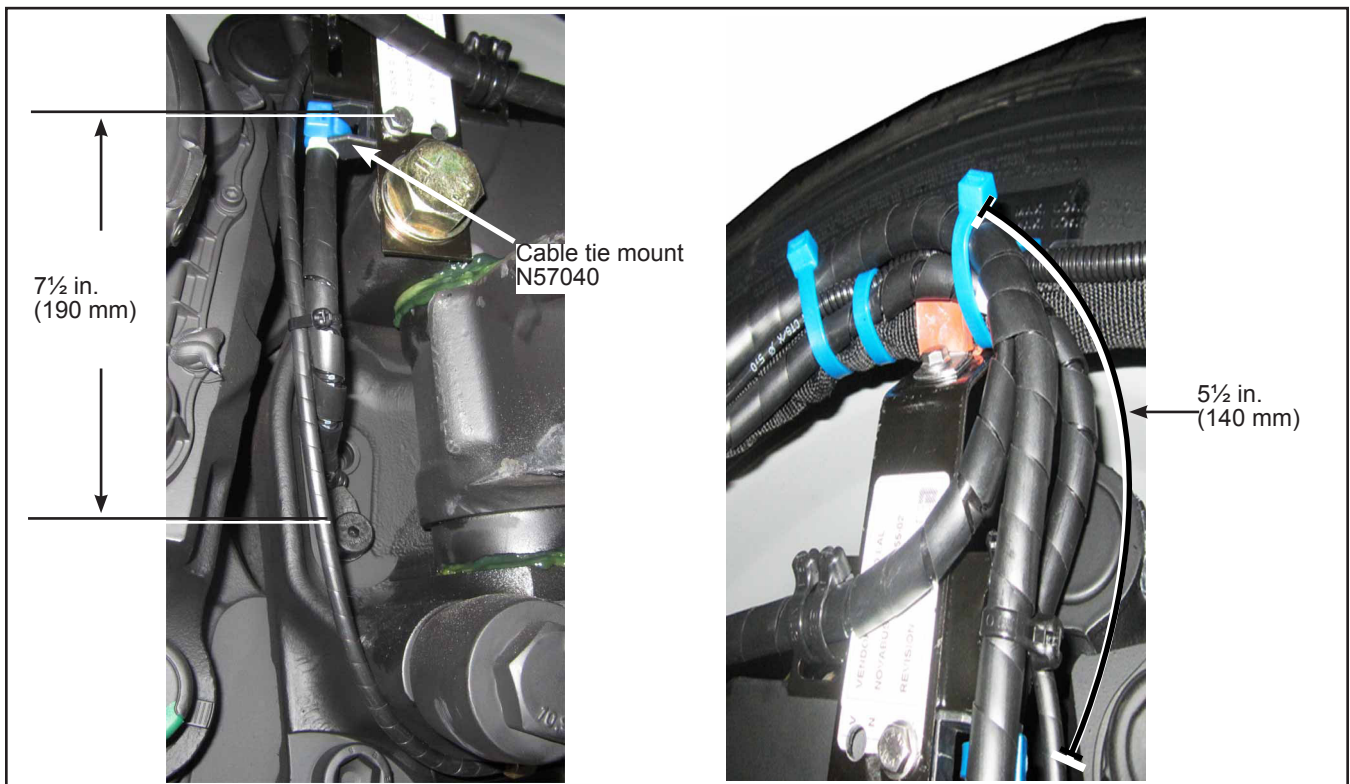

Figure 15 - Fastening of Harness With Tie-Wraps

2.20. Affix the electrical harness to the brake hose using tie-wraps, as shown in Figures 15 and 16. Distance between tie-wraps is typical. If necessary, install additional tie-wraps.

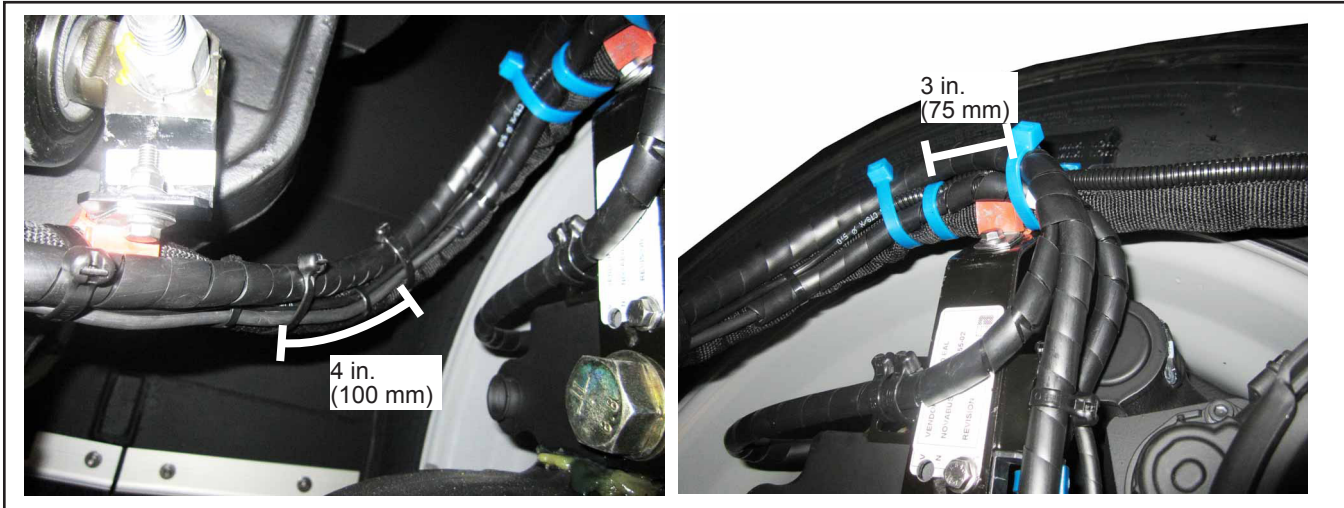

Figure 16 - Electrical Harness Attached to the Brake Hose



NOTE

See Figures 17 and 18 for the reference points when measuring brake hoses and electrical harnesses.

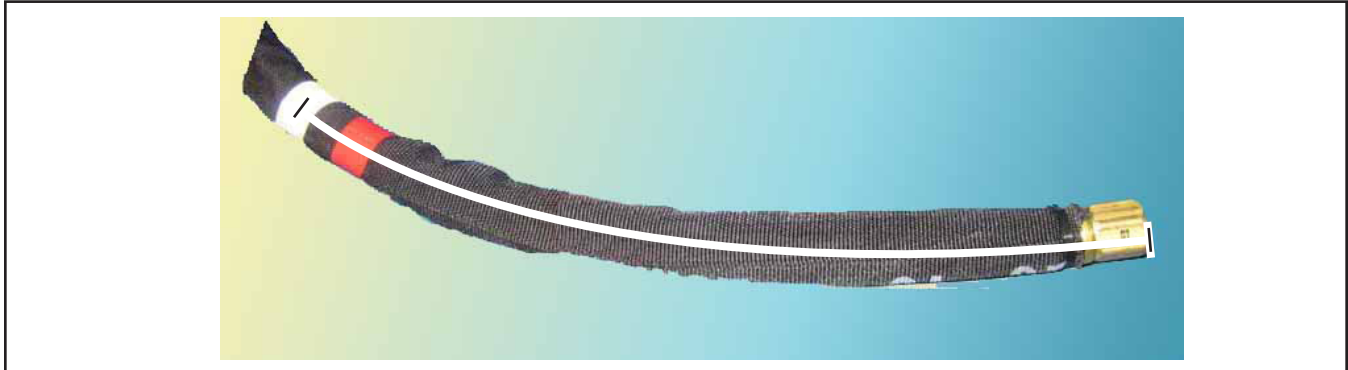

Figure 17 - Reference Points for Measuring a Brake Hose (Typical)

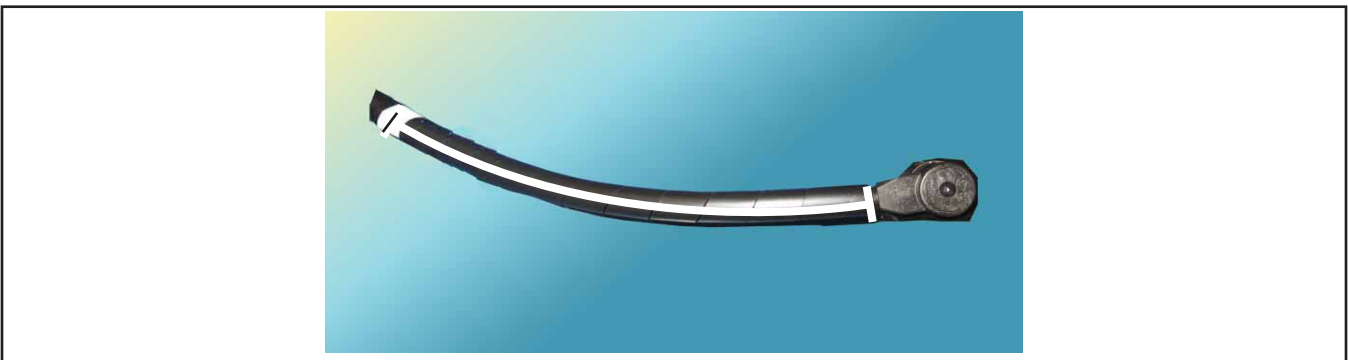

Figure 18 - Reference Points for Measuring an Electrical Harness (Typical)

REAR AXLE ABS SENSOR ELECTRICAL HARNESS

- 2.21. Remove the tie wrap from the ABS sensor's electrical harness.
- 2.22. If required, remove other tie wraps to facilitate the marking and positioning of the electrical harness.

DRIVER SIDE ELECTRICAL HARNESS

- 2.23. Mark the electrical harness at the position indicated in Figure 19.
- 2.24. Mark the brake hose the position indicated in Figure 19.
- 2.25. Affix the electrical harness to the brake hose with a tie-wrap at the tie point indicated in Figure 19. If required, affix with other tie wraps.

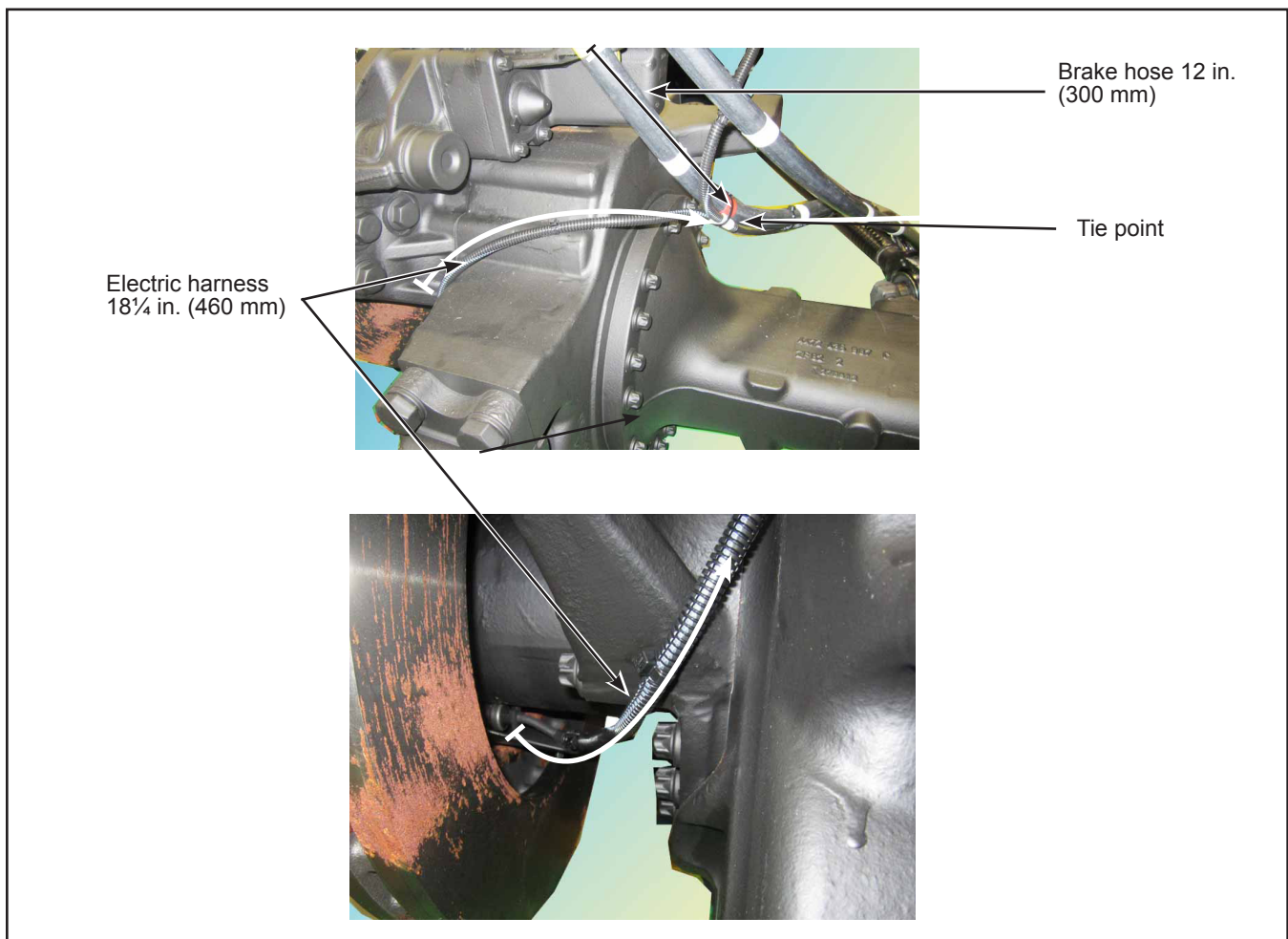

Figure 19 - Driver Side Electrical Harness Routing

CURB SIDE ELECTRICAL HARNESS

- 2.26. Mark the electrical harness at the position indicated in Figure 20.
2.27. Mark the brake hose at the position indicated in Figure 20.
2.28. Affix the electrical harness to the other electrical harness at tie point#1 with a tie wrap. See Figure 20.

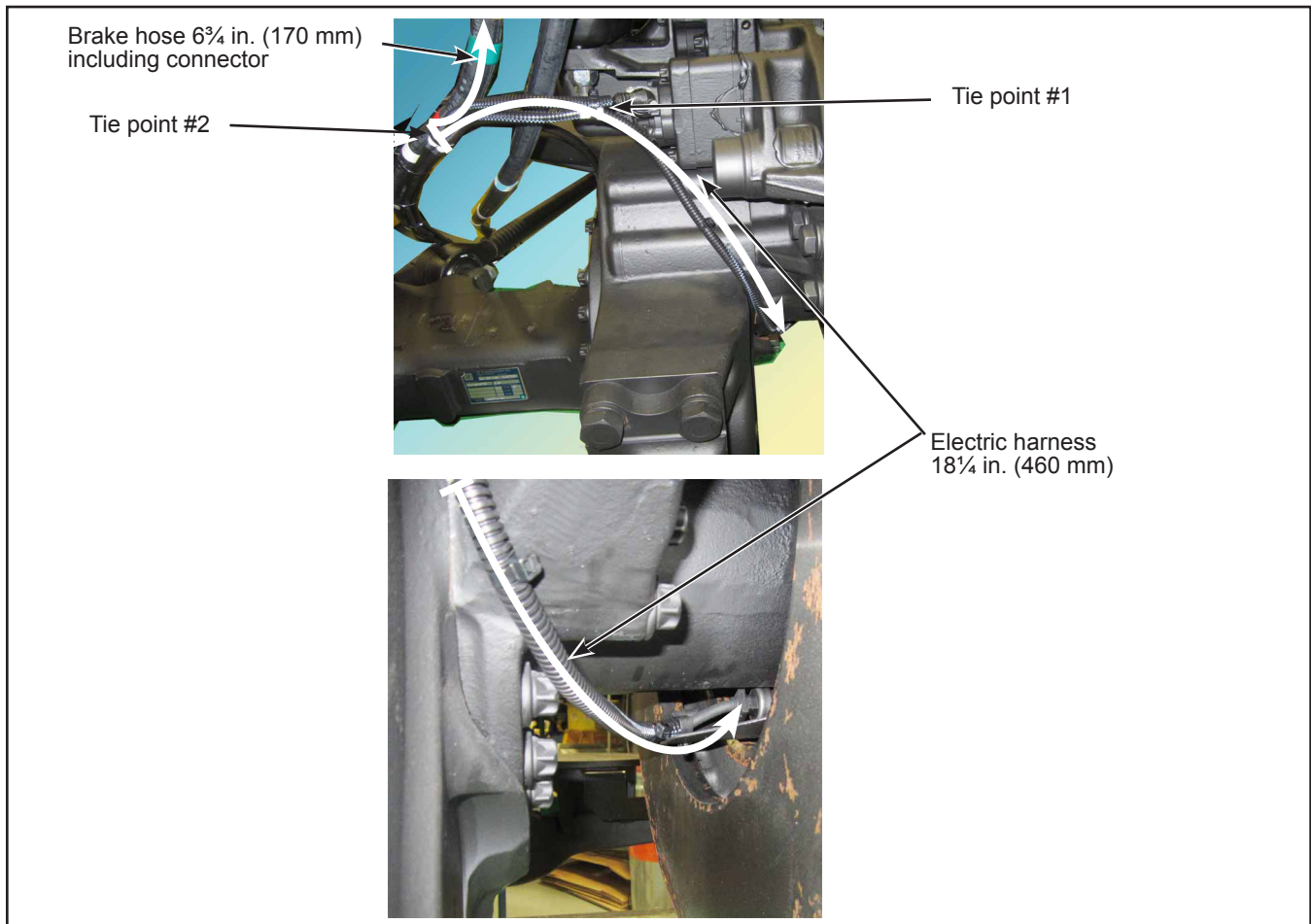

Figure 20 - Curb Side Electrical Harness Routing

- 2.29. Affix the electrical harness to the brake hose at tie point #2 with a tie wrap. If required, install additional tie wraps.
2.30. Lower the vehicle.

**NOTE**

With the aid of an assistant, ensure that there is no contact between the brake hoses and their surrounding components by fully turning the front wheels to the left and the right. During these maneuvers, ensure that the steering radius is sufficient and that the hoses do not collapse. Make sure the hoses are not strained by suspension travel. Correct if necessary, then repeat these verification steps until the desired outcome is achieved.

- 2.31. Verify that all bolts and nuts are well tightened.
2.32. The vehicle may be returned to service.❖