

Service

This manual is to be used by qualified appliance technicians only. Maytag does not assume any responsibility for property damage or personal injury for improper service procedures done by an unqualified person.

Commercial Top Load Washer

This Base Manual covers general information
Refer to individual Technical Sheet
for information on specific models

This manual includes, but is
not limited to the following:

MAT12PDA
MAT12PDB
MAT12PDC
MAT12PDD
MAT12PDS
MAT12PRA
MAT12PRB
MAT12PRD
MAT12PRS
MAT12PSA
MAT12PSB
MAT12PSD
MAT12CSA
MAT12CSD
MAT13MNA
MAT13MND
MAT13PNA
MAT13PND

Important Information

Important Notices for Servicers and Consumers

Maytag will not be responsible for personal injury or property damage from improper service procedures. Pride and workmanship go into every product to provide our customers with quality products. It is possible, however, that during its lifetime a product may require service. Products should be serviced only by a qualified service technician who is familiar with the safety procedures required in the repair and who is equipped with the proper tools, parts, testing instruments and the appropriate service information. **IT IS THE TECHNICIANS RESPONSIBILITY TO REVIEW ALL APPROPRIATE SERVICE INFORMATION BEFORE BEGINNING REPAIRS.**



WARNING

To avoid risk of severe personal injury or death, disconnect power before working/servicing on appliance to avoid electrical shock.

To locate an authorized servicer, please consult your telephone book or the distributor from whom you purchased this product. For further assistance:

Contact your local commercial product distributor or visit Web site www.maytagcommerciallaundry.com

Recognize Safety Symbols, Words, and Labels



DANGER

DANGER—Immediate hazards which **WILL** result in severe personal injury or death.



WARNING

WARNING—Hazards or unsafe practices which **COULD** result in severe personal injury or death.



CAUTION

CAUTION—Hazards or unsafe practices which **COULD** result in minor personal injury, product or property damage.

Table of Contents

Important Information	2	Disassembly Procedures(continued)	
Important Safety Information	4	Pressure Switch	19
General Information		Air Dome	19
Model Identification	7	Water Valve	20
Model Nomenclature	7	Meter Case	20
How It Works	8	Coin Slide	20
Tools For Servicing	10	Coin Drop Acceptor	20
Troubleshooting Procedures		Coin Sensor	21
Mechanical Troubleshooting	11	Service Door Switch	21
Drive Lug Adjustment	12	Coin Vault Switch	21
Damper Pad Noise	12	Lid	21
Pump Belt Adjustment	12	Front Panel	22
Electrical Troubleshooting	13	Top Cover	22
Component Testing	14	Tub Cover	22
Motor Testing	14	Balance Ring	22
Disassembly Procedures	16	Agitator	23
Control Panel	16	Access Plug	23
MN (Manual) Timer	16	Inner Tub	23
CS (Coin Slide) Timer	16	Mounting Stem	24
Control Board (Microprocessor)	16	Outer Tub	24
Touch Pad	17	Tub Bearing	24
Cycle Selector Switch	17	Transmission	25
Transformer	17	Lip Seal	26
Motor Run Relay	17	Damper Assembly	27
Reversing Motor Relay	18	Brake Package and Radial Bearing	27
Indicator Light	18	Belts	28
Lid Switch Assembly (Prior series 15)	18	Drive Pulley and Rotor Bearing	28
Lid Switch Assembly (After series 15)	18	Pump	29
Unbalance Lever and Plunger Assembly	19	Drive Motor and Motor Base	29

Important Safety Information



WARNING

To reduce the risk of fire, electric shock, serious injury or death to persons when using your washer, follow these basic precautions:

- Read all instructions before using the washer.
- Refer to the Grounding Instructions in the Installation Manual for the proper grounding of the washer.
- Do not wash articles that have been previously cleaned in, washed in, soaked in, or spotted with gasoline, dry-cleaning solvents, or other flammable or explosive substances as they give off vapors that could ignite or explode.
- Do not add gasoline, dry-cleaning solvents, or other flammable or explosive substances to the wash water. These substances give off vapors that could ignite or explode.
- Under certain conditions, hydrogen gas may be produced in a hot water system that has not been used for two weeks or more. Hydrogen gas is explosive. If the hot water system has not been used for such a period, before using a washing machine or combination washer-dryer, turn on all hot water faucets and let the water flow from each for several minutes. This will release any accumulated hydrogen gas. The gas is flammable, do not smoke or use an open flame during this time.
- Do not allow children to play on or in the washer. Close supervision of children is necessary when the washer is used near children. This is a safety rule for all appliances.
- Before the washer is removed from service or discarded, remove the lid to the washing compartment.
- Do not reach into the washer if the wash tub is moving.
- Do not install or store the washer where it will be exposed to water and/or weather.
- Do not tamper with the controls.
- Do not repair or replace any part of the washer, or attempt any servicing unless specifically recommended in the User-Maintenance instructions or in published user-repair instructions that you understand and have the skills to carry out.
- To reduce the risk of an electric shock or fire, do not use an extension cord or an adapter to connect the washer to the electrical power source.
- Use your washer only for its intended purpose, washing clothes.
- Always disconnect the washer from electrical supply before attempting any service. Disconnect the power cord by grasping the plug, not the cord.
- Install the washer according to the Installation Instructions. All connections for water, drain, electrical power and grounding must comply with

local codes and be made by licensed personnel when required. Do not do it yourself unless you know how!

- To reduce the risk of fire, clothes which have traces of any flammable substances such as vegetable oil, cooking oil, machine oil, flammable chemicals, thinner, etc. or anything containing wax or chemicals such as in mops and cleaning cloths, must not be put into the washer. These flammable substances may cause the fabric to catch on fire by itself.
- Do not use fabric softeners or products to eliminate static unless recommended by the manufacturer of the fabric softener or product.
- Keep your washer in good condition. Bumping or dropping the washer can damage safety features. If this occurs, have your washer checked by a qualified service person.
- Replace worn power cords and/or loose plugs.
- Be sure water connections have a shut-off valve and that fill hose connections are tight. Close the shut-off valves at the end of each wash day.
- Loading lid must be closed any time the washer is in operational fill, tumble, or spin. Do not attempt to bypass the loading lid switch by permitting the washer to operate with the loading lid open.
- Always read and follow manufacturer's instructions on packages of laundry and cleaning aids. Heed all warnings or precautions. To reduce the risk of poisoning or chemical burns, keep them out of the reach of children at all times (preferably in a locked cabinet).
- Always follow the fabric care instructions supplied by the garment manufacturer.
- Never operate the washer with any guards and/or panels removed.
- Do not operate the washer with missing or broken parts.
- Do not bypass any safety devices.
- Failure to install, maintain, and/or operate this washer according to the manufacturer's instructions may result in conditions which can produce bodily injury and/or property damage.

NOTE: The Warnings and Important Safety Instructions appearing in this manual are not meant to cover all possible conditions and situations that may occur. Common sense, caution and care must be exercised when installing, maintaining, or operating the washer.

Always contact your dealer, distributor, service agent or the manufacturer about any problems or conditions you do not understand.

Important Safety Information

WARNING

To avoid personal injury or death from improper servicing, make sure you read and understand the descriptions and meaning of various safety symbols, words and labels used in this manual, before attempting any procedures described in the manual. Failure to understand and comply with safety information may result in severe personal injury or death.

General Information

This Service Manual describes the operation, disassembly, troubleshooting, and repair of Maytag® washing machines. It is intended for use by authorized technicians who troubleshoot and repair these units.

NOTE: It is assumed that users of this manual are familiar with the use of tools and equipment used to troubleshoot and repair electrical, and mechanical systems; and understand the terminology used to describe and discuss them.

Related Publications

This is a base service manual, covering a range of similar models. It is intended to be used in conjunction with the Parts Manual and Technical Sheet covering the specific model being serviced.

Electrical Service Information

Proper Grounding and Polarization of 120 Volts Wall Outlets

For the safety of our customers and the Service Technician ALL appliances have a three-prong power cord and MUST be connected to a properly polarized AND grounded wall outlet.

This information was written for those who do not understand grounding and polarization of a wall outlet. A 120 volt wall outlet must always be wired as shown below.

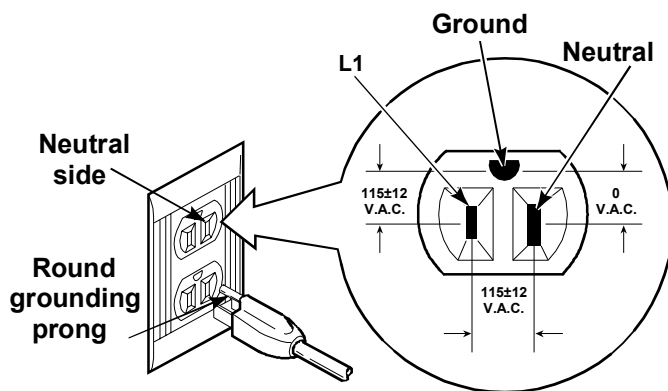

About Ground Wires

In the event of an electrical short circuit, a ground wire reduces the risk of electric shock by providing an escape wire for the electric current.

Standard accepted color coding for ground wires is **green** or **green with a yellow stripe**.

Grounding wires and wires colored like grounding wires are **NOT** to be used as current carrying conductors.

WARNING

To reduce the risk of fire, electric shock, serious injury or death, all wiring and grounding must conform with the latest edition of the National Electric Code, ANSI/NFPA 70, or the Canadian Electrical Code, CSA C22.1, and such local regulations as might apply. It is the customer's responsibility to have the wiring and fuses checked by a qualified electrician to make sure your home has adequate electrical power to operate the washer.

WARNING

To avoid risk of personal injury or death due to electrical shock:

- **Observe all local codes and ordinances.**
- Disconnect electrical power to unit before servicing.
- Ground appliance properly.
- Check with a qualified electrician if you are not sure this appliance is properly grounded.
- DO NOT ground to gas line.
- DO NOT ground to cold water pipe if pipe is interrupted by plastic, nonmetallic gaskets, or other insulating (nonconducting) materials.
- DO NOT modify plug on power cord. If plug does not fit electrical outlet, have proper outlet installed by qualified electrician.
- DO NOT have a fuse in the neutral or ground circuit. A fuse in the neutral or ground circuit could result in an electrical shock.
- DO NOT use an extension cord with this appliance.
- DO NOT use an adapter plug with this appliance.
- DO NOT pinch power cord.

Important Safety Information

Explanation

Polarization—This means that the larger slot must be neutral and the small slot must be at line voltage.

Mispolarized—The outlet is incorrectly wired so that the larger slot is at line voltage and the smaller slot is neutral.

Grounded—This means the round hole connection is connected to earth ground through a connection to the main power panel.

Ungrounded—The round hole connection is not complete to earth ground and/or the main power panel.

Grounding Instructions



WARNING

- To avoid the risk of electrical shock or death, do not alter the plug.
- Do not remove grounding prong when installing grounded appliance in a home that does not have three wire grounding receptacle. Under no condition is grounding prong to be cut off or removed. It is the personal responsibility of the consumer to contact a qualified electrician and have properly grounded three prong wall receptacle installed in accordance with appropriate electrical codes
- To avoid the risk of electrical shock or death, this equipment must be grounded.

This equipment **MUST** be grounded. In the event of an electrical short circuit, grounding reduces the risk of electric shock by providing an escape wire for the electric current. This unit is equipped with a cord having a grounding wire with a grounding plug. The plug must be plugged into an outlet that is properly installed and grounded.

Consult a qualified electrician or technician if grounding instructions are not completely understood, or if doubt exists as to whether the equipment is properly grounded. Do not use an extension cord. If the product power cord is too short, have a qualified electrician install a three-slot receptacle. This unit should be plugged into a separate 60 hertz circuit with the electrical rating as shown in the appropriate drawing. Models operate with a supply voltage of 120 Volts.

General Information

Model Identification

Model and serial number is located on the back of the console and cabinet. It is important that you keep a record for future reference.

- For Maytag product call your distributor or visit the Web Site at www.maytagcommerciallaundry.com

When contacting provide product information located on rating plate. Record the following:

Model Number: _____

Serial or S/N Number: _____

Date of purchase: _____

Distributor name and address: _____

Service

Keep a copy of sales receipt for future reference or in case warranty service is required. To locate an authorized distributor:

- For Maytag product call your distributor or visit the Web Site at www.maytagcommerciallaundry.com.

Service should be performed by qualified service technicians. We also recommend contacting an authorized distributor, if service is required.

Parts and Accessories

Purchase replacement parts and accessories over the phone. To order accessories for your product call:

- or Maytag product call your distributor or visit the Web Site at www.maytagcommerciallaundry.com.

Only factory approved replacement parts should be used.

Commercial Washer Nomenclature

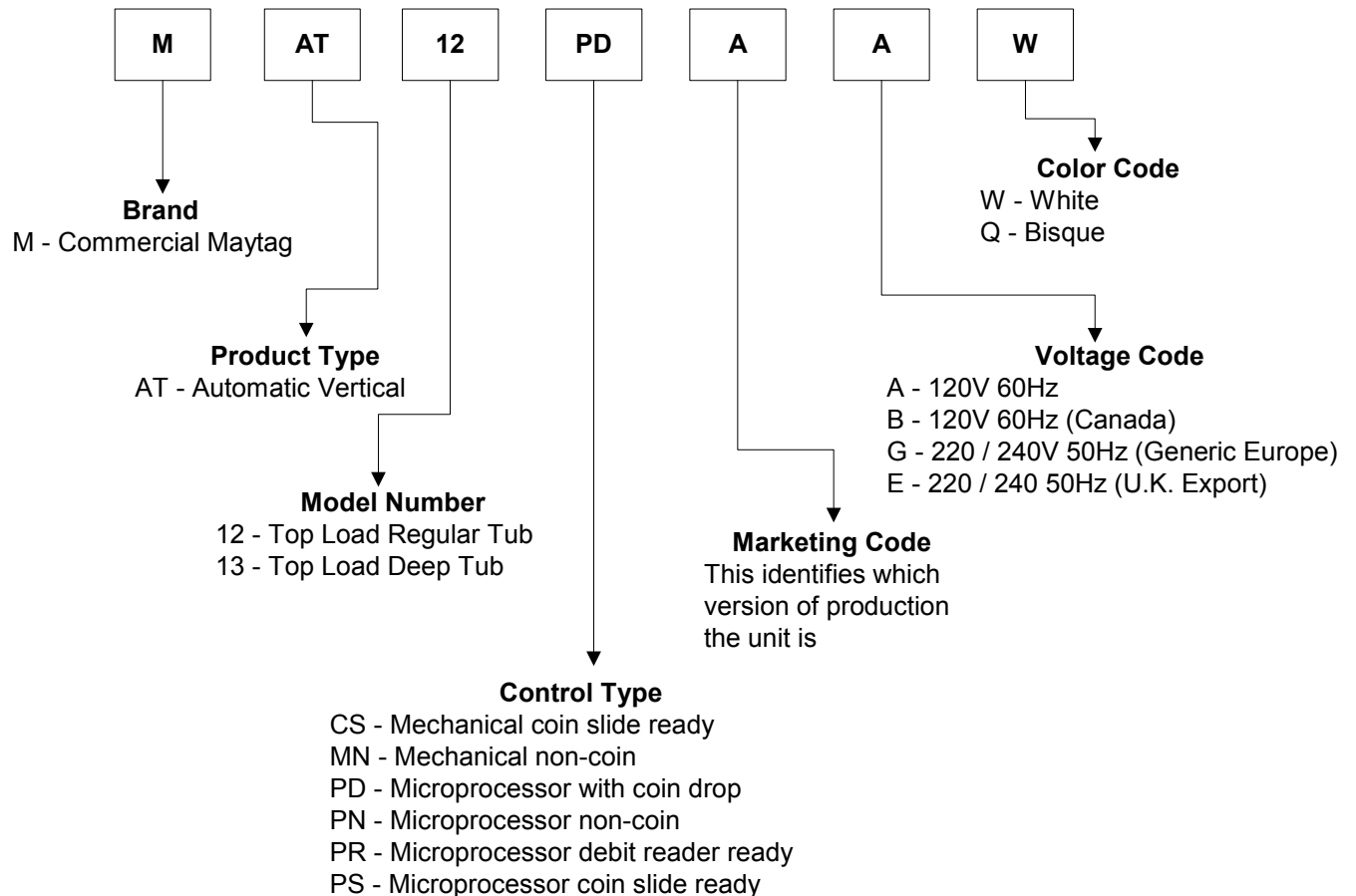

General Information

HOW IT WORKS

The cycles are made up of three basic operations Fill, agitate and drain/spin. These operations are sequenced by the controls (timer or microprocessor board) to provide a proper cleaning cycle for each of several different fabrics.

FILL

Pressurized hot and cold water supplies are required. The dynamic, or flow pressure should be between 30 lbs. per square inch and 80 lbs. per square inch (p.s.i.). Pressure below 20 lbs p.s.i. may cause water line hammering.

Hot water is describe to be 140° F and cold water temperature should be 75° F. A 50-50 mix of hot water and cold should result in warm temperature between 100° F and 105° F.

The components involved in a fill operation are the water valve assembly, the water level control and the timer or control board. The control board or timer along with the selector switch tell the valve whether to allow hot, cold or both (warm) into the washer. The water level control (a.k.a. pressure switch) controls the level of the water in the washer. It should be at the top row of holes (perforations) in the washer basket plus or minus 1/4 inch.

Water Valve (Non-Thermostatic)

The water valve used on the top load washers is designed to operate with in a pressure range of 30-120 p.s.i.. Flow pressure cannot fall below 20 p.s.i. or valves may fail to close when solenoids are de-energized.

Water from source enters valve at inlet and pushes up on diaphragm. The solenoid plunger and the plunger spring are not strong enough to hold the diaphragm in a closed position. The diaphragm lifted and some water will flow under the diaphragm and into the outlet.

Some water also flows through bleeder holes in the diaphragm and into the guide tube area behind the diaphragm. With the solenoid not energized, the plunger would block the pressure release hole allowing the guide tube to pressurize to source pressure. This causes the diaphragm to be pushed against the valve seat blocking the valve seat and closing the outlet.

While there is equal pressure (source pressure) on both sides of the diaphragm, the pressure in the guide tube area covers a greater surface area of the diaphragm. The center (outlet area) on the bottom side of the diaphragm is at atmospheric pressure so the valve remains closed. It

is important to understand that water pressure is the operation force in the water valve.

When the valve operating solenoid is energized, a magnetic field is produced that lifts the plunger away from the pressure release hole in the center of the diaphragm. The pressure in the guide tube area is released through the hole allowing the inlet pressure to lift the diaphragm off of the outlet seat. Water flows under the diaphragm and out through the valve outlet.

Because the bleed holes cannot allow water into the guide tube area as rapidly as it can escape out through the pressure release hole, the diaphragm will remain in the open position as long as the plunger is held away from the release hole.

When the plunger is released (solenoid coil de-energized), it again blocks the release hole allowing pressure entering through the bleed holes to again force the diaphragm back against the outlet seat, stopping the flow of water. A nozzle arrangement at the center of the diaphragm causes the valve closure to be gradual and smooth to reduce the chances of water hammer as the valve closes.

Water Level Control (Pressure Switch)

The water level switch is a single pole-double throw switch which is activated by air pressure increase against a sealed diaphragm. An air hose is connected to a spout at the bottom of the outer water container (outer tub) and to an inlet spout at the water level control body.

As water enters the tubs and the water level raises, air is trapped in the air dome at the bottom of the pressure switch hoses. As the water level increases, this air is pushed up the hose and against the diaphragm in the water level control body.

The control is designed to cause the contact points to switch when the water level in the wash basket (and the outer container) reach a particular level. At that point the fill circuits are disconnected and the motor circuit is energized. This corresponds to empty = fill and full = run.

Air leaks at the hose connections cannot be tolerated for proper operation of the water level control.

In timer models, a bypass circuit is provided by the timer and selector switch to continue power to the motor in spin operations. Without the bypass, the drive motor would stop when sufficient water had been pumped out of the washbasket to cause the pressure switch to reset to the "empty" position. Microprocessor models do not need the bypass circuit.

General Information

DRIVE MOTOR

When the water level/pressure switch is satisfied circuits are completed to the main drive motor. The drive motor is a special high torque split-phase, four pole motor. Two windings are used. The run winding is designed for full time use in wash and spin. A second winding, called the auxiliary or "start" winding is used to provide starting torque and determine direction of rotation. A centrifugal switch is mounted to the upper end bell of the motor and serves to disconnect the start winding as the motor reaches running speed.

Contact sets in a timer or in a motor reversing relay provide proper connection to the motor to cause it to run clockwise in agitate and counterclockwise in spin (viewed from the top).

The motor drives the power unit by means of a special design "V" belt. The belt has a "slip factor" designed to act as a slip clutch.

TRANSMISSION

The helical drive shaft drives a pinion gear (which is splined to the top of the drive shaft) at approximately 618 r.p.m. This drives the bevel gear at approximately 150 r.p.m.

The pivot pin of the yoke portion of the torque block and yoke assembly is driven in a circular motion (orbit) around an imaginary center point of the bevel gear center axis. The yoke drives the torque block back and forth through an arc of approximately 97 degrees at the rate of about 150 times per minute. Because this is a continuous motion, the drive provides very smooth operation. The low number of parts results in improved dependability. This gear case can be serviced without removing it from the washer.

HELICAL DRIVE

The helical drive mechanism used in the washer is simple - not requiring a special device or linkage to shift the washer from agitation to spin.

The drive mechanism utilizes a reversible motor and helical (threaded) drive shaft. A pulley which is threaded to the helical drive shaft moves either up or down the shaft dependent upon the direction it is turned by the drive motor by means of a drive belt.

AGITATION

When the pulley is turning counterclockwise (viewed from the bottom) it moves down the helical drive shaft. As it

rotates down the shaft, a lug on the pulley comes against a drive lug which is splined to the helical drive shaft. At this point the drive shaft turns with the pulley. The pulley bearing which merely resting on top of the pulley also rotates with the pulley, drive lug and helical drive shaft.

At the top of the drive shaft is a spined gear. As it rotates it drives a series of gears causing the agitator to move back and forth in an arc creating the water action for the wash.

The tub and transmission are locked in place and cannot turn because the brake rotor and brake shoe (which is splined to the transmission) is being held down against the brake drum by the brake spring.

SPIN

When the motor reverses, the pulley will turn in a clockwise (viewed from the bottom). This causes the pulley and bearing to turn. The pulley climbs the threads on the helical drive shaft overcoming the force of the brake spring to lift the brake rotor and brake shoe off the brake drum.

As the pulley climbs the shaft and overcomes the force of the brake spring, there is a downward pull on the shaft.

Within the transmission there are two washers which act as a spin clutch. This is a friction clutch consisting of a bronze washer which is splined to and turns the drive shaft. Between this washer and the pinion gear is a steel washer which is locked to the transmission case.

As the helical shaft is pulled downward, the two clutch washers under the pinion are forced together. This is done rapidly and slippage occurs only during the first two or three revolutions, until the film of oil between the two clutch washers is forced out.

The drive occurs when the washers are forced together and the pulley has climbed the shaft as far as it can. The driving force has locked the pulley, brake rotor, drive tube and gear case together and all will turn as a unit in the same direction as the pulley is turning, causing the tube to spin in a counterclockwise direction (as viewed from the top).

Spin cycle completed:

When the washer reaches the end of the spin cycle, the drive force is removed. Thus, there is no force supplied to lock the components together or to compress the brake spring. Therefore, the downward force of the brake spring and the momentum of the spinning washbasket effectively reverse all the actions outlined above.

General Information



WARNING

To avoid risk of electrical shock, personal injury or death from improper servicing, make sure you understand the proper procedures and usage of tools listed, before attempting any procedures described in the manual. Failure to understand and comply with safety information may result in severe personal injury or death.

TOOLS FOR SERVICING

The following is a list of tools used to service the commercial top load washer.

Part Number	Description
<input type="checkbox"/>	Test Meters <input type="checkbox"/> Appliance Test Meter (AC-DC voltage and Ohmmeter) <input type="checkbox"/> Clamp-On Ammeter
<input type="checkbox"/> 038138	Motor Test Cord
<input type="checkbox"/> 2000021	Lip Seal Tool
<input type="checkbox"/> 22038313	Tub Nut spanner Wrench
<input type="checkbox"/> 038315	Brake Package Wrench
<input type="checkbox"/> 038323	Agitator Puller
<input type="checkbox"/> 038327	Motor Pulley Puller
<input type="checkbox"/> 038555	Center Shaft Installation Tool
<input type="checkbox"/> 20001028	T-15 Torx bit
<input type="checkbox"/> 038227	T20H Torx bit
<input type="checkbox"/> 20001052	T25H Torx bit
<input type="checkbox"/> 20001025	#3 Pozi-Drive bit
<input type="checkbox"/> 038184	Water Hardness Test Kit
<input type="checkbox"/> 038195	Rust Test Capsules
<input type="checkbox"/> 056080	Transmission Oil
<input type="checkbox"/> 055978	Rubber Adhesive (yellow)
<input type="checkbox"/> 204999	Silicone Grease
<input type="checkbox"/> --	RTV Sealant Maytag
<input type="checkbox"/> --	1/4" nut driver or socket
<input type="checkbox"/> --	5/16" nut driver or socket
<input type="checkbox"/> --	3/8" nut driver or socket
<input type="checkbox"/> --	7/16" socket
<input type="checkbox"/> --	1/2" socket
<input type="checkbox"/> --	#2 "stubby" Phillips screwdriver
<input type="checkbox"/> --	#2 Pozi-Drive screwdriver

Troubleshooting Procedures



WARNING

To avoid risk of electrical shock, personal injury or death, disconnect power to unit before servicing, unless testing requires power.

Mechanical Troubleshooting

There are a number of factors which can contribute to noisy or improper washer operation. Some of these are listed below along with areas to check for possible corrections.

Condition	Possible Cause
1. Vibration Noise	<ul style="list-style-type: none"> • Control cover loose • Front panel loose • Entire washer <ul style="list-style-type: none"> ○ weak floor construction (reinforce) ○ inner Tub not centered ○ damper pads dry
2. Operation Noise	<ul style="list-style-type: none"> • Noise during agitation <ul style="list-style-type: none"> ○ check rotor bearing • Noise during spin <ul style="list-style-type: none"> ○ check tub bearing ○ check radial bearing
3. Water Leaks	<ul style="list-style-type: none"> • Water valve • Fill hoses • Hose clamps • Injector housing • Poly pump • Boot seal • Tub cover loose
4. Oil Leaks	<ul style="list-style-type: none"> • <u>Clear oil around inside of cabinet</u>; excess oil from tub bearing. Wipe off and wait to see if more develops. • <u>Oil under base</u>; wipe off and wait to see if more develops. It is probably excess oil from brake package. • Excess oil on helical shaft and in rubber dust cap. Replace lip seal in transmission.
5. Failure To Agitate Or Spin	<ul style="list-style-type: none"> • Belt broken or off pulley • Motor pulley off or loose • Transmission • Brake package loose
6. Poor Spin Out	<ul style="list-style-type: none"> • Belt off or broken • Dry or dirty motor base • Kinked drain hose • Clothing article between tubs • Pump belt too tight
7. Spins And Agitates At Same Time	<ul style="list-style-type: none"> • Drive lug adjustment • Clutch washer in transmission
8. Freewheeling Inner Tub	<ul style="list-style-type: none"> • Rotor bearing in upside down • Brake liner loose • Tub nut loose
9. Timer Shaft Hard to Pull Out (MN Models)	<ul style="list-style-type: none"> • Oil shaft where it goes into timer housing and work in and out until it loosens up (rust).
10. Warm Water Temperature Too Cold	<ul style="list-style-type: none"> • Increase temperature at hot water heater. • Clean inlet screen in hot water hose • Adjust hot and cold faucets to compensate
11. Slow Fill	<ul style="list-style-type: none"> • Plugged inlet screens in fill hoses and water valve • Inadequate water pressure (should be 30 – 120 p.s.i.)
12. Water Siphoning Out Of Washer	<ul style="list-style-type: none"> • Drain hose not 36" from floor <ul style="list-style-type: none"> ○ Raise drain hose to 365" ○ Install siphon break

Troubleshooting Procedures



WARNING

To avoid risk of electrical shock, personal injury or death, disconnect power to unit before servicing, unless testing requires power.

Drive Lug Adjustment

1. Disconnect power supply to unit.
2. Turn the drive pulley onto the shaft clockwise until all play is taken up.
3. Holding the pulley in this position, the distance between drive and pulley lugs should be $3/8$ ".
4. Turn pulley counterclockwise and check to see that the drive lug and pulley are making contact.

Note: There should always be clearance between the bottom of the pulley and the top of the stop lug to prevent the drive pulley from dragging on the drive lug, forcing it off the shaft.

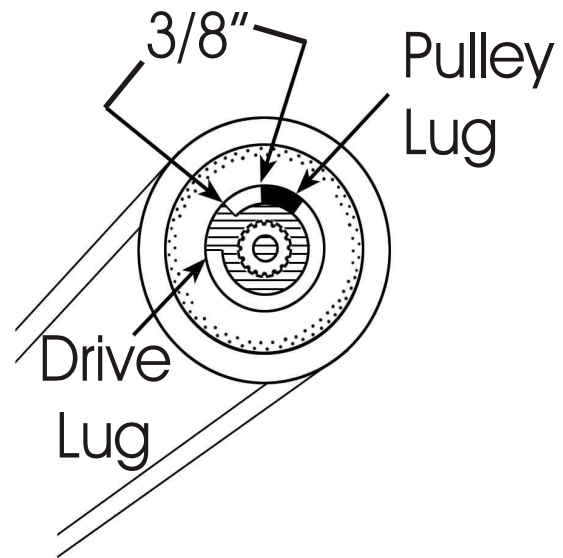

Damper Pad Noise

Dry or poorly lubricated damper pads can result in a rubbing noise during the beginning and end of the spin cycle. If this condition is encountered, the damper pads should be lubricated or replaced. See "Damper Assembly" in Disassembly Procedures Section of this manual.

Pump Belt Adjustment

1. Disconnect power supply to unit.
2. Pull motor forward so drive belt is tight.
3. With washer in an upright position, grasp the pump belt in the middle and flex. With the belt flexed, it should be tightened so that there is approximately $1/4$ " between the inside surfaces of the pump belt before movement of the motor is felt.
4. If necessary, tilt washer and loosen screws holding pump to base frame and position pump to attain the proper $1/4$ " dimension.

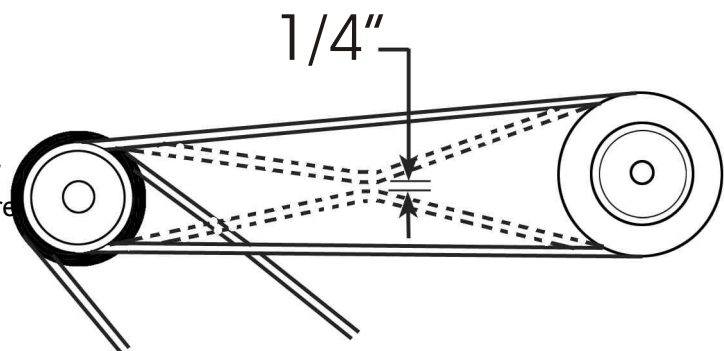

Troubleshooting Procedures



WARNING

To avoid risk of electrical shock, personal injury or death, disconnect power to unit before servicing, unless testing requires power.

ELECTRICAL TROUBLESHOOTING

The malfunction of an electrical circuit cannot easily be diagnosed unless you first understand how it functions when operating normally. The electrical schematic and wiring diagram includes a cycle sequence chart keyed to the contacts in the timer, relay and/or control switches.



CAUTION

Resistance or continuity testing is done with the product disconnected from power. Failure to do so can result in damage to your meter.

For the most part, we will only be concerned with continuity. Is there a path or not? References are made between a “closed” (Continuity) reading and an “open” (No continuity) reading. One note, when you get an “open” reading, try a higher resistance range (setting). A very high resistance appears as an “open” on the lower ranges. For best accuracy always “rezero” meter when changing ranges and/or the physical position of the meter.

Continuity testing, as related to an electrical component, is the check of a part for an “open” or “closed” circuit.

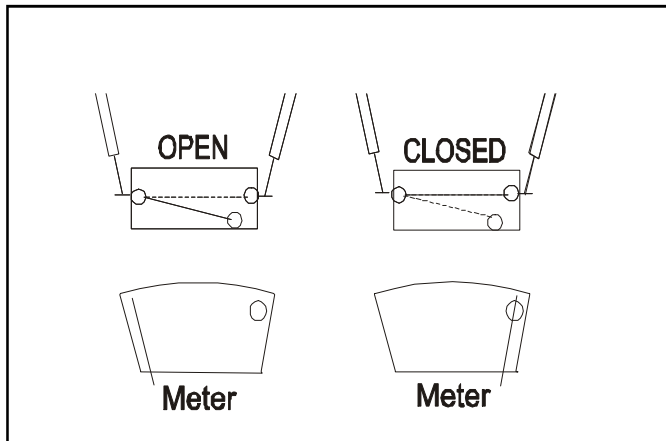

Electrical components fall into two general categories.

1. **Loads** - Devices that use or consume electricity. Examples would include drive motor, timer and solenoid coils.
2. **Switches** - Devices that control the supply of electricity to the load or loads in a circuit. Examples include lid switches, timer contacts selector switch and relay contacts.

Continuity test of “load” devices will show varying levels of resistance from very low for some transformer and motor windings to very high for some timer motors and components on control boards. Usually it is more important to know if there is a path for current flow through a device (continuity) than to know the exact resistance (ohms) of the device.

Continuity tests of switches will show virtually no resistance across a closed contact. Resistance, even low values indicate burned or dirty contacts in a switch.

When checking components or circuit paths for continuity, external wiring should be disconnected to eliminate false readings through external paths. Isolate what you want to test.





Troubleshooting Procedures

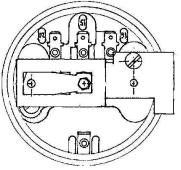
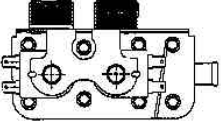

WARNING

To avoid risk of electrical shock, personal injury or death, disconnect power to unit before servicing, unless testing requires power.

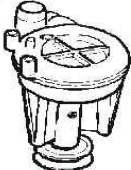
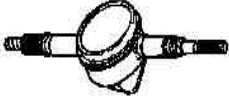
COMPONENT TESTING

Illustration	Component	Test Procedure	Results
	Pressure Switch	Disconnect wire terminals from switch. Measure resistance across the following terminals: Empty (Filling) 20 to 15----- Full (Run) 20 to 15 -----	Resistance above 2 Ω indicates dirty switch contacts. Closed circuit Open circuit
	Water Valve	Measure resistance across the terminals of each coil on the valve.	Approximately 850-950 Ω
	Motor	Type of Motor: Single speed (Split phase)	See "Motor" Testing section for correct wiring contact
	Pump	Verify drain pump is not clogged or damaged	1) Remove clog and verify proper operation 2) Replace drain pump if damaged
	Transmission	Type of transmission (orbital): 618 r.p.m. Spin 150 o.p.m. Agitate Check wattage with full tub of water only (Use Wattage Meter)	See "Transmission" Disassembly Procedures section. 380 to 420 watts
	Belts	Check belt for excessive wear or being burnt and cracking	Replace if belt if damaged

MOTOR TESTING

A motor test cord may be used to electrically check operation of the various electrical components without removing them from the unit. Testing in this manner merely determines whether or not part will function independently of other electrical components. In order to make accurate test, proper connection of the motor test cord is important.

All four leads of the test cord are required to test the washer drive motor. The following drawing shows installation of the test cord on washer drive motor. Reversing the motor from agitation to spin is accomplished by reversing the test cord wires B and C.

Troubleshooting Procedures



WARNING

To avoid risk of electrical shock, personal injury or death, disconnect power to unit before servicing, unless testing requires power.

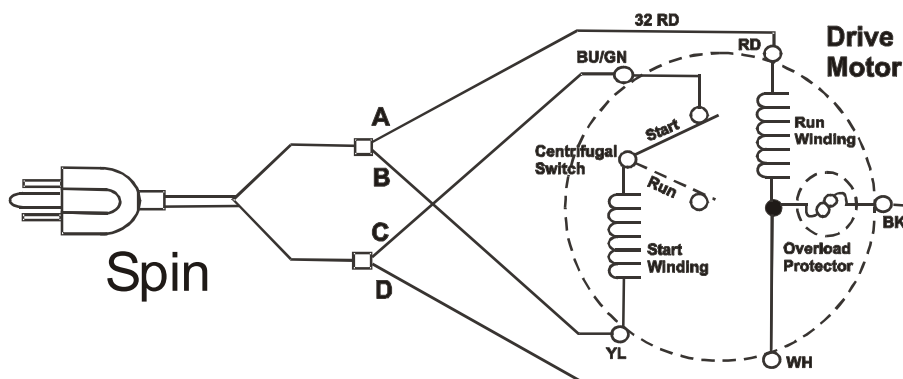
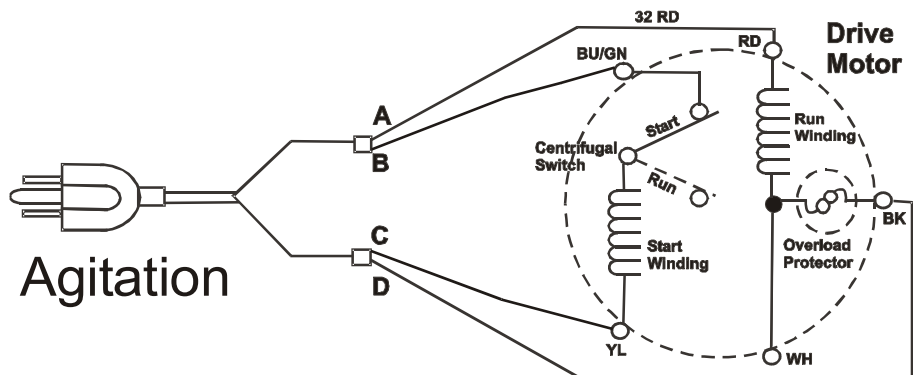

Windings	Wiring Harness Connections	Readings
Run Winding	Red to White or Black	1.5Ω
Start Winding	Yellow to Blue	3Ω
Over-load	White to Black	0 Ω

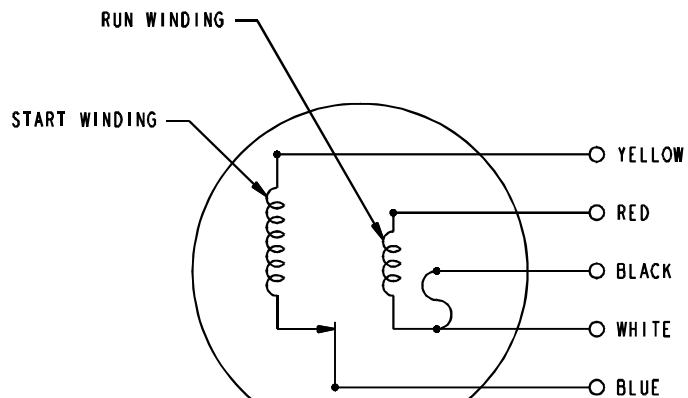

Note: Export Motors-run windings 4.9Ω, start windings 20.5Ω, over-load 0 Ω.

Disassembly Procedures



WARNING

To avoid risk of electrical shock, personal injury or death; disconnect power to unit before servicing.

Control Panel

1. Disconnect power supply to unit.
2. Remove top two T-20H Torx screws located on the front of the control panel.
3. Carefully lay the control panel forwards.

Note: Use a protective cloth to minimize the chance of scratching the panel on the control console.

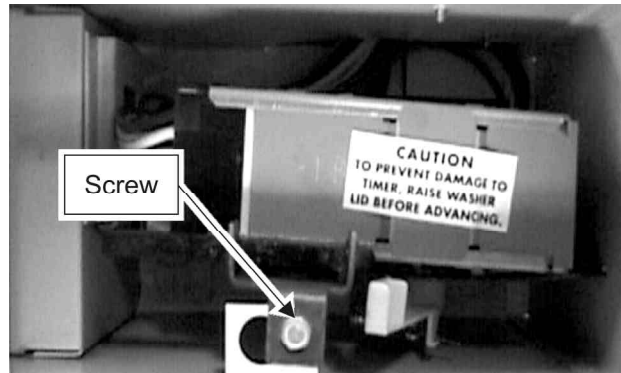
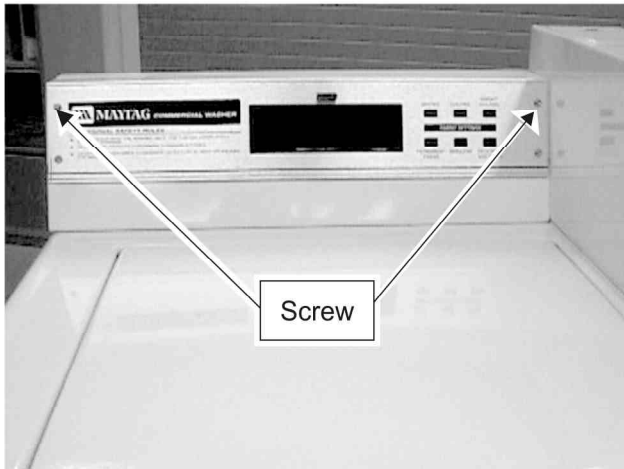

5. Squeeze tabs to remove connectors from timer.

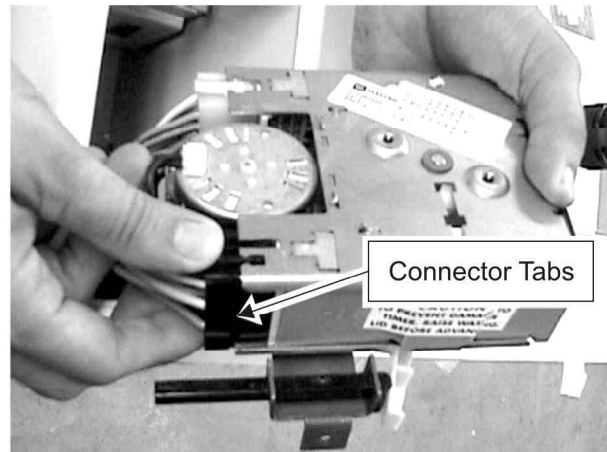

MN (Manual) Model Timer

1. Disconnect power supply to unit.
2. Carefully pry the timer knob center cap out of the knob.
3. Slip the retainer clip off of the timer shaft.

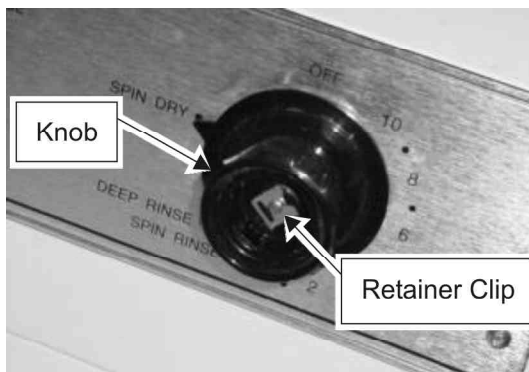

4. Pull the knob, spring and dial off of the timer shaft.
5. Remove screws securing Timer to Control Panel.
6. Remove Control Panel.

Control Board (Microprocessor)

1. Disconnect power supply to unit.
2. Remove Control Panel.
3. Remove four 5/16" nuts from backup plate mounting studs.

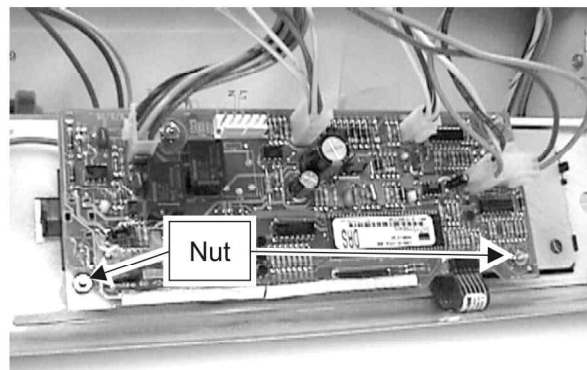

4. Lift board from studs and tilt forward. Don't lose the spacers.
5. Disconnect touch pad ribbon. Grasp touch pad "tail" between your thumbs and forefinger. Ribbon can be pulled out of receptacle.

CS (Coin Slide) Model Timer

1. Disconnect power supply to unit.
2. Use key to gain access through service door.
3. Remove screw securing timer bracket to meter case.
4. Lift timer and bracket up and forward from the meter case.

Note: Extra wire (slack) can be fed from the left.

Disassembly Procedures



WARNING

To avoid risk of electrical shock, personal injury or death; disconnect power to unit before servicing.

Touch pad

1. Disconnect power supply to unit.
2. Remove all four T-20H Torx screws securing control panel facia.
3. Remove Control Panel.
4. Remove Control Board.
5. Remove two Pozi-drive screws securing touch pad to Control panel.

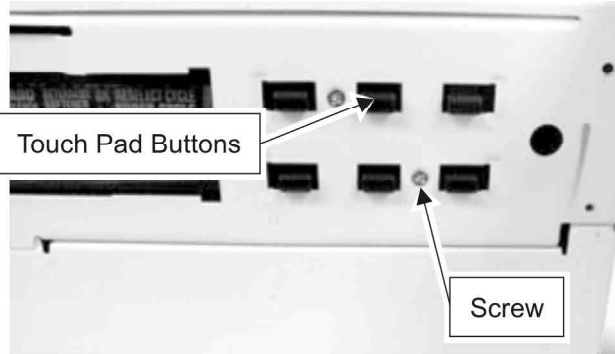

5. Lay control panel forward.
6. Remove wires from switch (note switch position) and remove switch.

Note: When replacing switch, note the position of “top” on the switch.

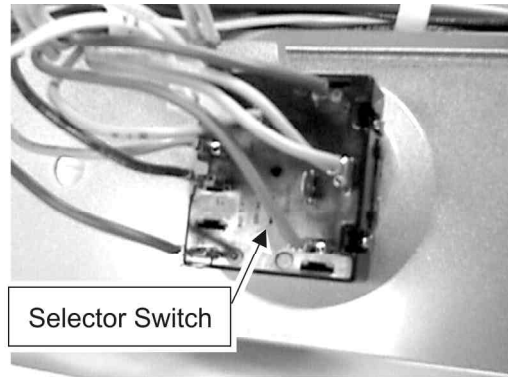

Cycle Selector Switch

1. Disconnect power supply to unit.
2. Remove all four T-20H Torx screws securing control panel facia.

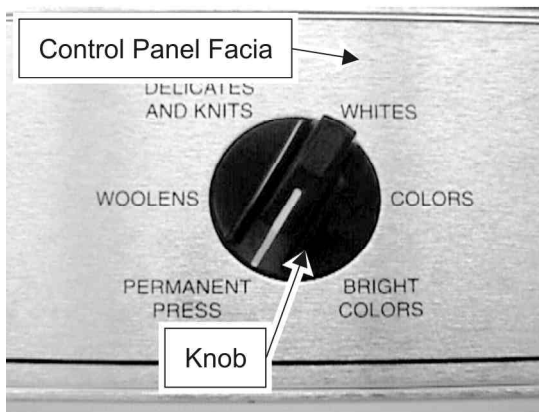

3. Pull selector switch knob off switch shaft.
4. Remove two screws holding switch to control panel.

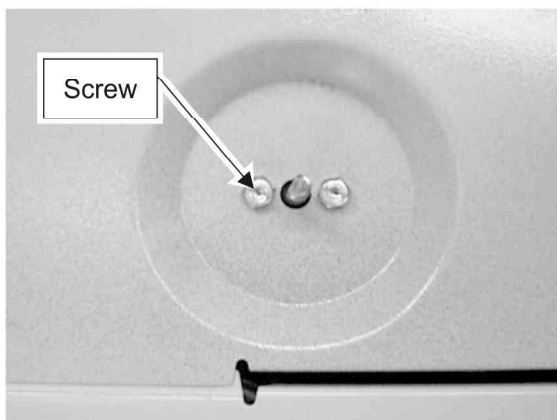

Transformer

1. Disconnect power supply to unit.
2. Remove Control Panel.
3. Remove two screws securing transformer and disconnect wire harness.

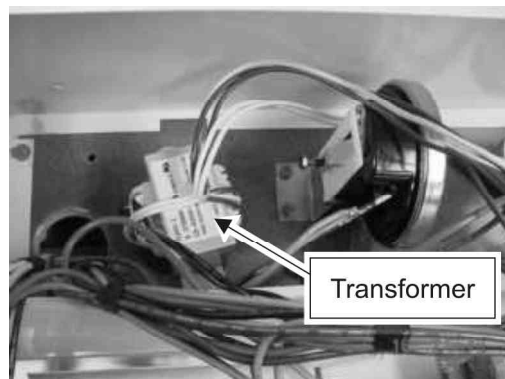

Motor Run Relay

1. Disconnect power supply to unit.
2. Remove Control Panel.
3. Disconnect wires from Motor Relay.
4. Remove screw securing relay to Control Panel.

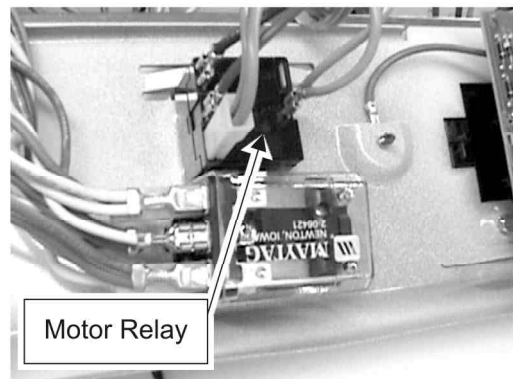

Disassembly Procedures



WARNING

To avoid risk of electrical shock, personal injury or death; disconnect power to unit before servicing.

Reversing Motor Relay

1. Disconnect power supply to unit.
2. Remove all four T-20H Torx screws securing control panel facia.
3. Disconnect all wires attached to Reversing Motor Relay.
4. Remove single screw securing relay.

Note: Notice the positioning tab for ease in mounting and locating relay onto the Control Panel.

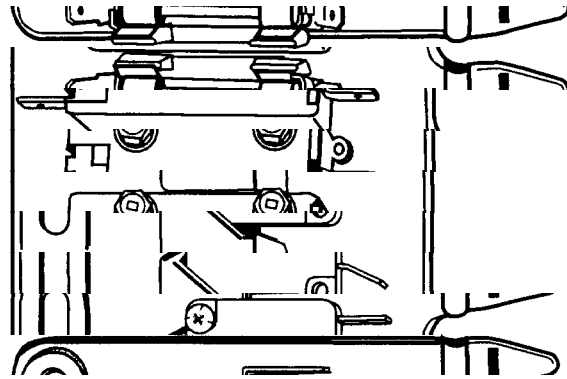
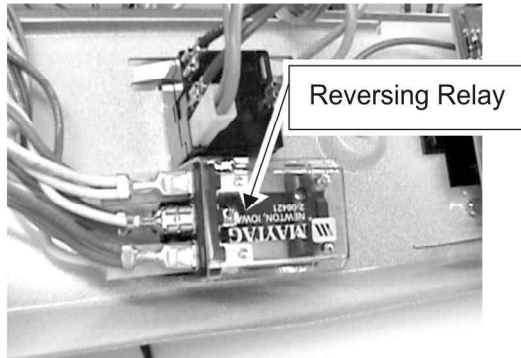

Lid Switch Assembly (After series 15)

1. Disconnect power supply to unit.
2. Remove Control Panel
3. Remove wire connector attached to the switch.

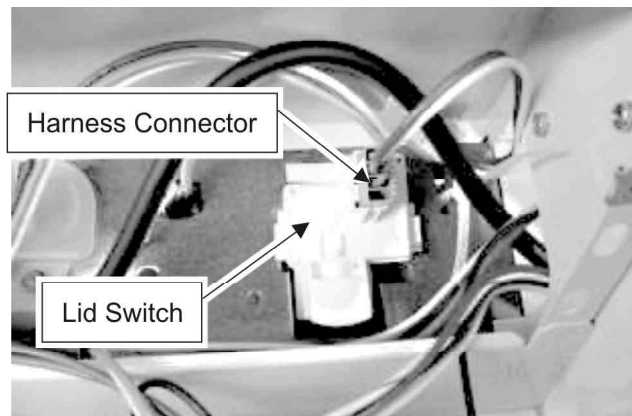

Indicator Light (Timer models)

1. Disconnect power supply to unit.
2. Remove Control Panel.
3. Compress tab on the end of the Indicator Light and remove from back side of Control Panel.
4. Remove wires from assembly.

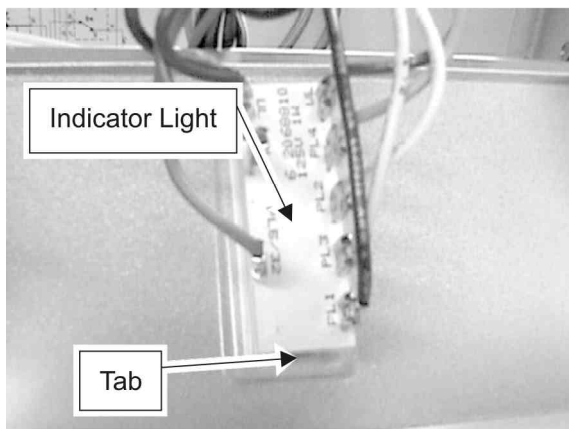

4. Lift tab and move switch forward and out.

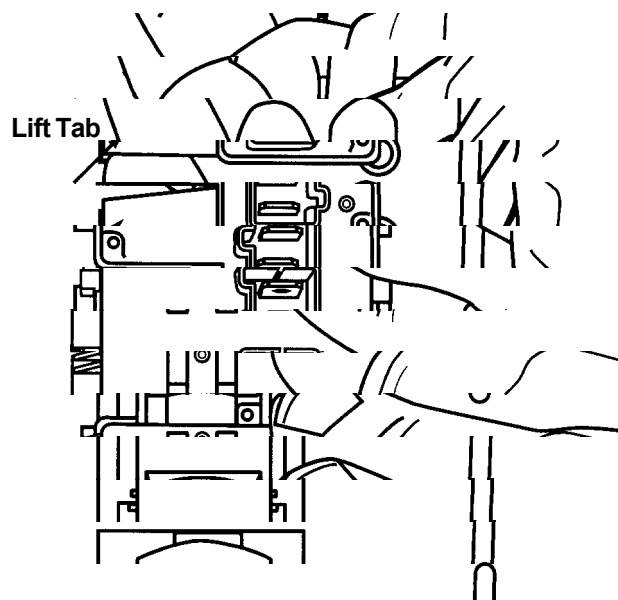

Lid Switch Assembly (Prior series 15)

1. Disconnect power supply to unit.
2. Remove Control Panel.
3. Remove wires attached to switches and fuse.
4. Remove adjusting screw securing lid switch bracket to the top cover.

Disassembly Procedures



WARNING

To avoid risk of electrical shock, personal injury or death; disconnect power to unit before servicing.

Reinstalling Lid Switch

1. Insert the lid switch assembly in the Top Cover (Push the switch assembly straight down and back until it locks in place).

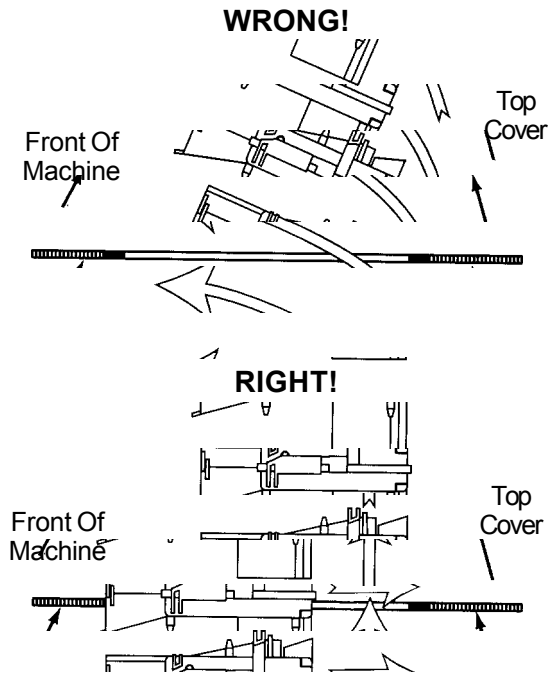

Pressure Switch

1. Disconnect power supply to unit.
2. Remove Control Panel.
3. Disconnect wires attached to the switch.
4. Remove clamp securing Air Dome Hose.
5. Remove two screws securing Pressure Switch to the Top Cover.

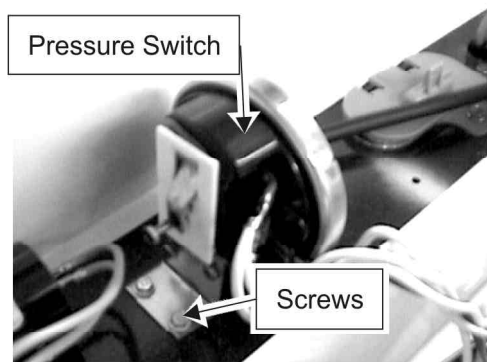

Air Dome

1. Disconnect power supply to unit.
2. Remove Control Panel and rear access service plate.
3. Remove clamp securing rubber hose to the Pressure Switch.
4. Remove clamp securing Air Dome to the Outer Tub spout.

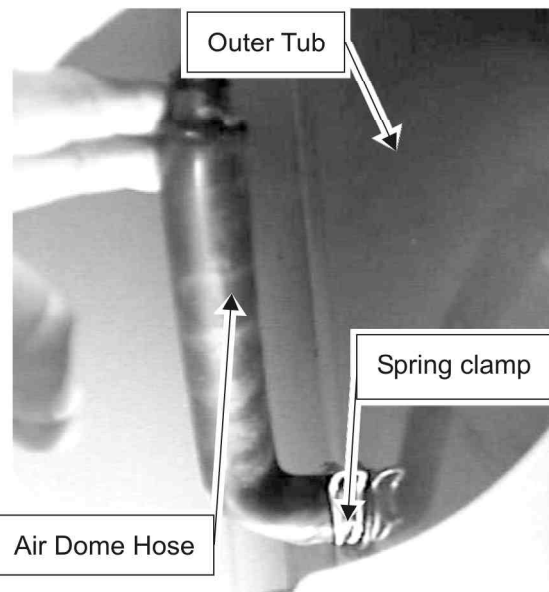

Unbalance Lever and Plunger Assembly

1. Disconnect power supply to unit.
2. Remove Lid and tilt the Top cover backwards.

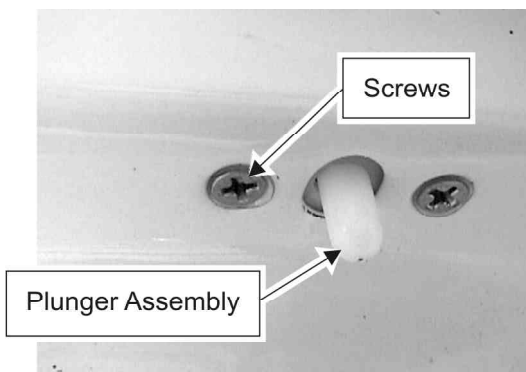

3. Remove two screws securing the plunger assembly to the Top Cover.

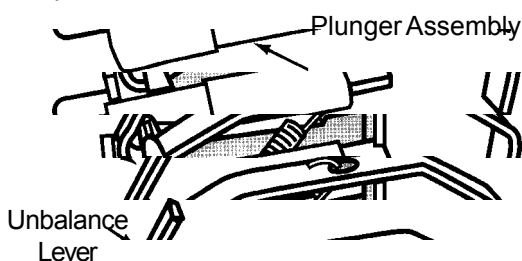

5. Disconnect rubber air tube secured to the cabinet.
6. Remove the air dome hose through the rear access opening.

Disassembly Procedures



WARNING

To avoid risk of electrical shock, personal injury or death; disconnect power to unit before servicing.

Water Valve

1. Disconnect power supply to unit.
2. Remove screw holding Valve Bracket to back panel.
3. Pivot out until flange clears back and lift up to disengage the bracket from the slot on the back panel.
4. Remove two screws holding Water Valve to mounting bracket.

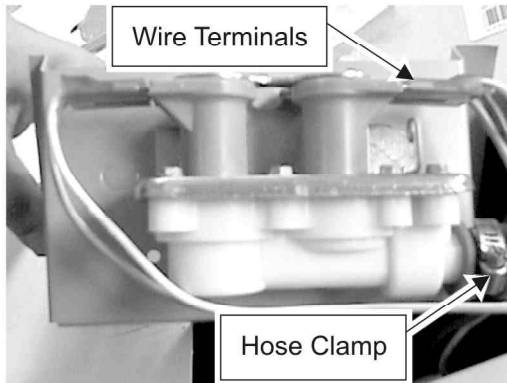

5. Disconnect wires from terminals.
6. Remove injector hose.

5. Remove Control Panel.
6. Remove screws securing console to meter case.
7. Remove two nuts (one inside coin box area and inside service access door compartment.).

Coin Slide

1. Disconnect power supply to unit.
2. Unlock and remove service access door.
3. Loosen the locking bolt from inside the meter case.
4. Pull the coin slide out of the Meter Case.

Note: The timer Actuator can be adjusted once the Coin slide is removed. The holes on the actuator are slotted to allow proper length adjustments (the actuator must be adjusted for the particular coin slide to advance the timer into the cycle).

Coin Drop Acceptor

1. Disconnect power supply to unit.

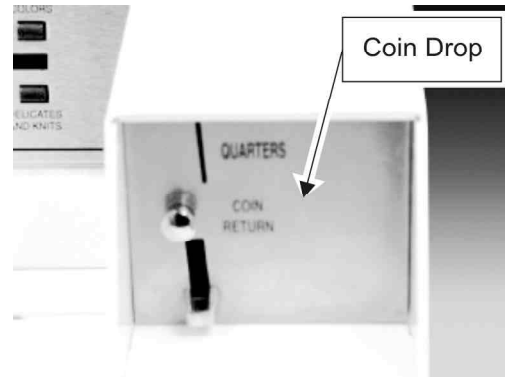

Meter Case

1. Disconnect power supply to unit.
2. Remove Service Access Door.

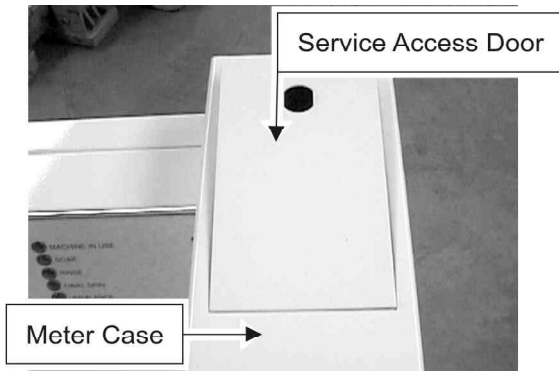

3. Remove coin box.
4. Remove timer or disconnect wires to Service and Vault Switches.

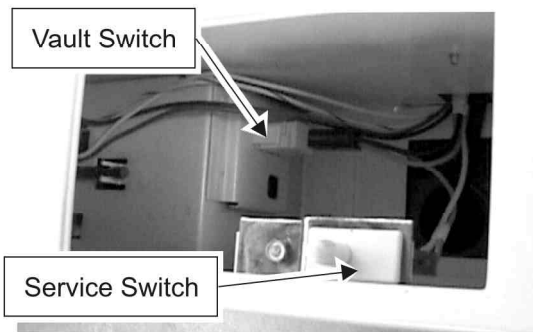

2. Unlock service access door.
3. Loosen the two locking bolts from inside the meter case.
4. Remove Coin Drop Acceptor.
5. Remove screw securing Coin Sensor to the rear of the Coin Drop Acceptor.

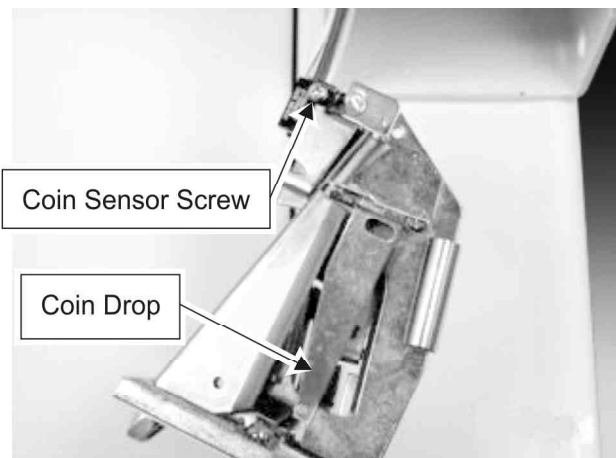

Disassembly Procedures



To avoid risk of electrical shock, personal injury or death; disconnect power to unit before servicing.

Coin Sensor

1. Disconnect power supply to unit.
2. Remove Control Panel and disconnect Coin Sensor connector plug on the Control Board.
3. Unlock service access door.
4. Remove Coin Drop Acceptor.

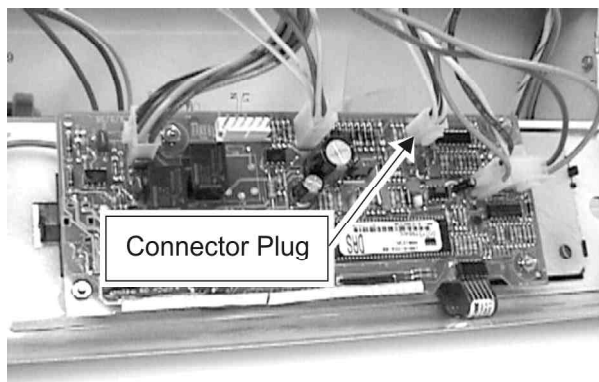

Lid

1. Disconnect power supply to unit.
2. Raise the lid where it is at a 45 degree angle.
3. With the left hand, grasp the left side of the lid toward the back. With the right hand, grasp the right side of the lid at the front right corner.
4. Taking care to watch the right hinge ball, pull towards you with the right hand. When the lid is disengaged from the right side of the top cover, catch the right hinge ball, remove the lid and catch the left hinge ball.

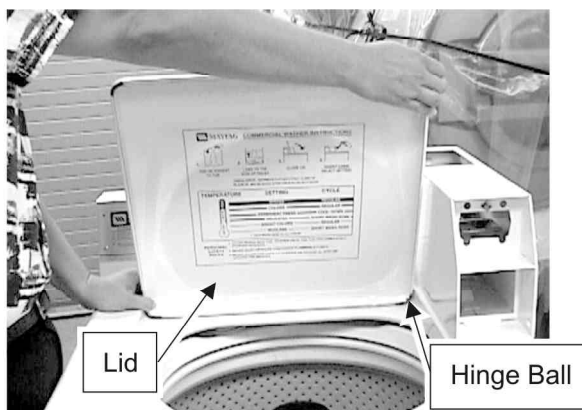

Service Door Switch

1. Disconnect power supply to unit.
2. Remove Service Access Door.
3. Remove the screw securing the switch mounting bracket and lift the switch from inside the Meter Case.

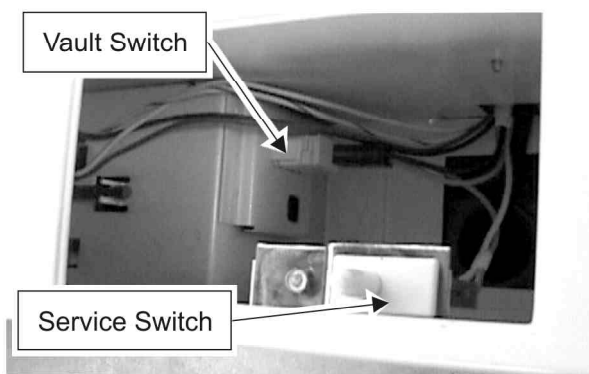

Reinstalling the Lid

1. Place a hinge ball in the recess of the left side of the top cover. Holding it in position, place the lid over the ball so the ball is in the recess on the left side of the lid.

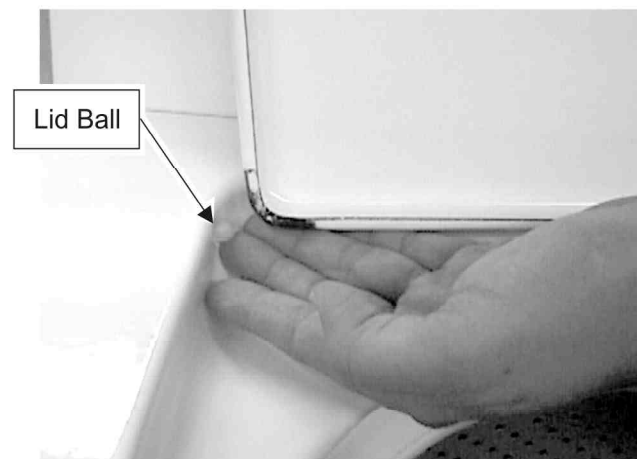

4. Disconnect wires from the switch, and squeeze tabs on switch to remove from bracket.

Coin Vault Switch

1. Disconnect power supply to unit.
2. Remove Service Access Door and Coin Box.
3. Disconnect wires from the switch.
4. Squeeze the two tabs on the switch and push the switch through towards the front.

2. Hold the lid with the left hand as shown, keeping sufficient pressure against the left side to ensure the hinge ball will remain wedged between the lid and the top cover.
3. With the right hand, place a hinge ball in the right side of the Top Cover recess.
4. Push the lid down against the hinge ball on the right side and with the right thumb. Press down sharply to engaged the lid with the hinge ball on the right side.

Disassembly Procedures



WARNING

To avoid risk of electrical shock, personal injury or death; disconnect power to unit before servicing.

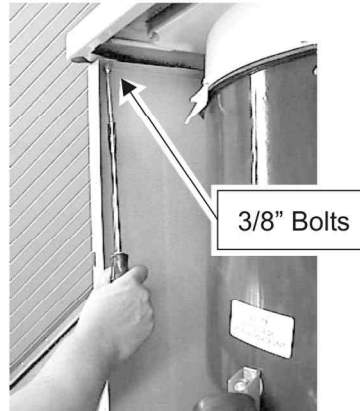
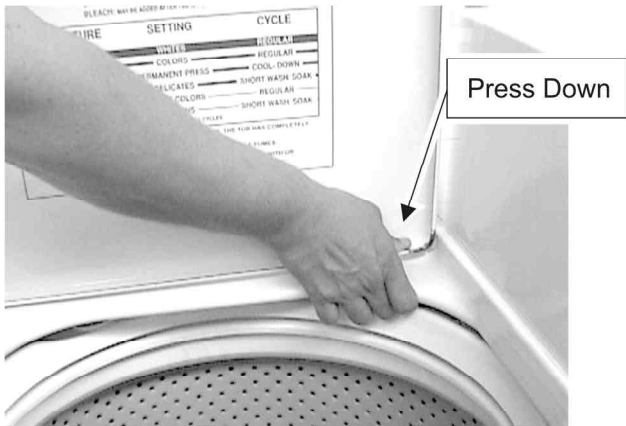

Note: If the fit between the right hinge ball and the lid is so tight you cannot press it into position with the right thumb, carefully strike the right corner of the lid with the palm of the hand to snap it into position.

Tub Cover

1. Disconnect power supply to unit.
2. Secure Lid to the Top cover.
3. Remove Front Panel.
4. Remove screw securing Top cover to the cabinet.
5. Tilt Top back.
6. Remove tub cover by unsnapping the tabs securing Tub Cover to the Outer Tub.

Front Panel

1. Disconnect power supply to unit.
2. Remove two T-25H Torx screws securing front panel.
3. Pull front panel up and away from the bottom.

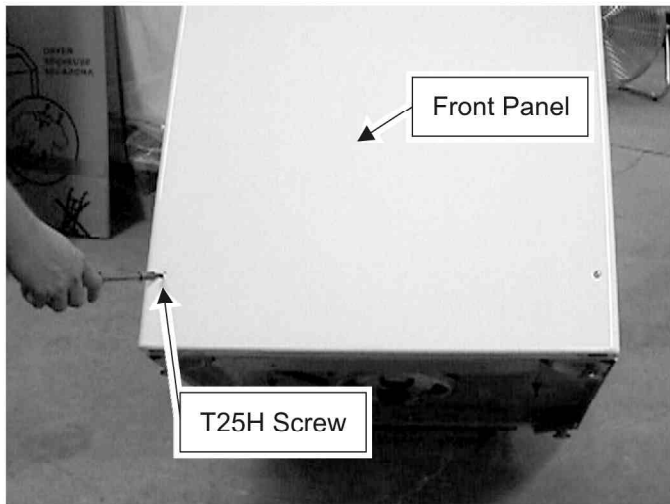
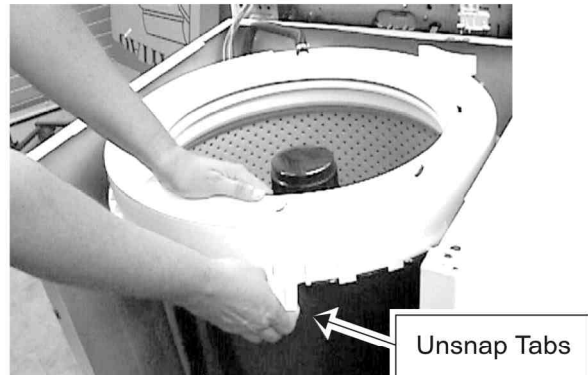

Balance Ring

1. Disconnect power supply to unit.
2. Remove Tub Cover.
3. Insert a pencil or other small pin through the three small holes in the outer tub depressing the tabs on the Balance Ring.

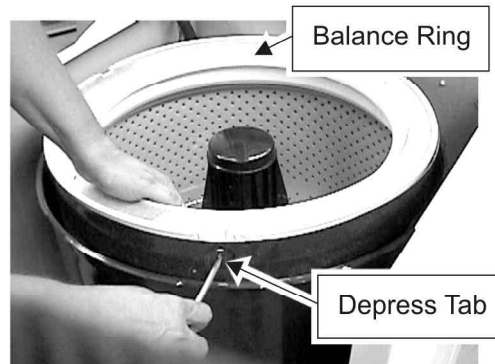

Top Cover

1. Disconnect power supply to unit.
2. Remove Front Panel.
3. Remove two top cover bolts and tilt Top Cover back.

Note: Hold lid closed or tape lid to the Top Cover to prevent it from striking the Control Panel.

Disassembly Procedures



To avoid risk of electrical shock, personal injury or death; disconnect power to unit before servicing.

Note: Try using a thin piece of cardboard to place between the tab and outer tub once you have inserted the pencil through the hole to depress the tabs. This will allow you to work on the other tabs for easy removal.

4. Remove Tub Cover.
5. Remove Agitator.
6. Use spanner wrench to remove clamping nut.

Note: This is a left hand thread so it must be turned clockwise. A mallet will be required to loosen the nut. Use care when striking wrench to prevent chipping the tub.

Agitator

1. Disconnect power supply to unit.
2. Loosen 1/4" hex head screw and lift Agitator up.

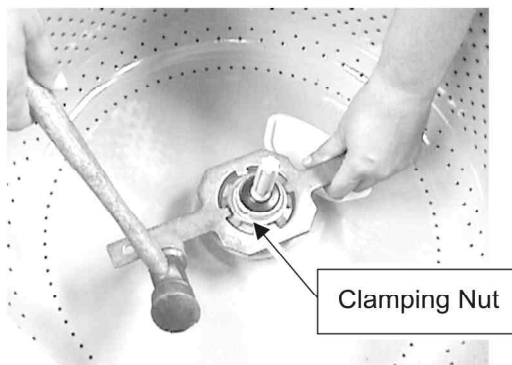
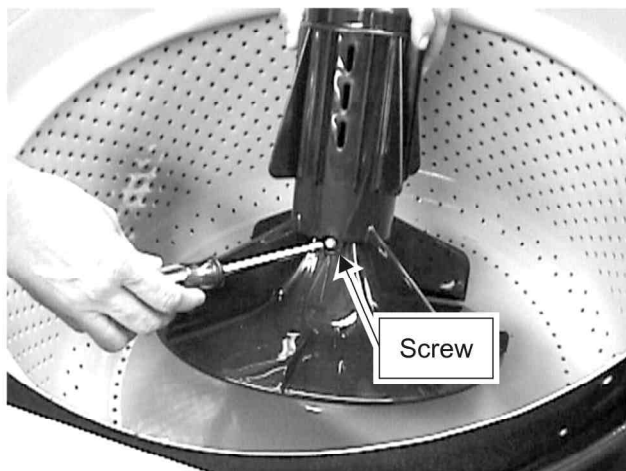

7. Remove clamping nut washer.

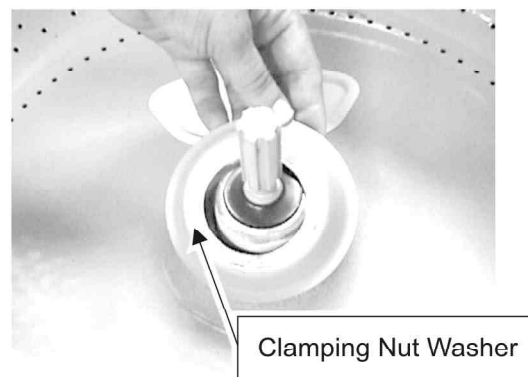

Access Plug

1. Disconnect power supply to unit.
2. Remove Agitator.
3. Pry out Access Plug.

Note: Grasp plug in the center on the long side. Lift up and push in at the same time to remove plug.

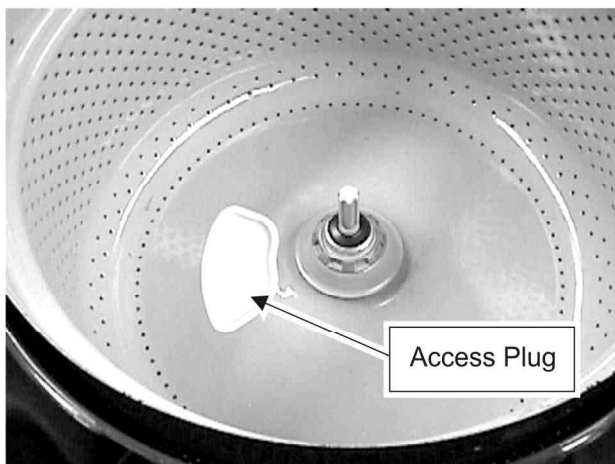

8. Lift Inner Tub Out. (Inner tub is lighter if Balance Ring has been removed.)

Note: When reinstalling Inner Tub. Rock Inner Tub back and forth on the mounting stem to make sure it is seated properly. Use care when tightening clamping nut, not to chip Tub.

Tub Centering

1. Place a 1/2 lb. weight in the tub.
2. Allow the washer to reach full spin speed.
3. When washer reaches full spin speed, turn off power to the washer and allow the tub to come to a complete stop before opening lid. The opening in the tub cover should be centered with the opening in the top cover, but with a small portion of the tub cover visible at the back. This visible portion of the tub cover should not exceed 1/4".

Inner Tub

1. Disconnect power supply to unit.
2. Remove Front Panel.
3. Raise Top Cover.

Disassembly Procedures



To avoid risk of electrical shock, personal injury or death; disconnect power to unit before servicing.

4. If the proper amount of the tub cover is not visible at the back or the tub is off center on either side, tighten the opposite damper spring and recheck as outlined in previous steps.

Mounting Stem

1. Disconnect power supply to unit
2. Remove Inner Tub.
3. Remove T-20H Torx set screw in the Mounting Stem.

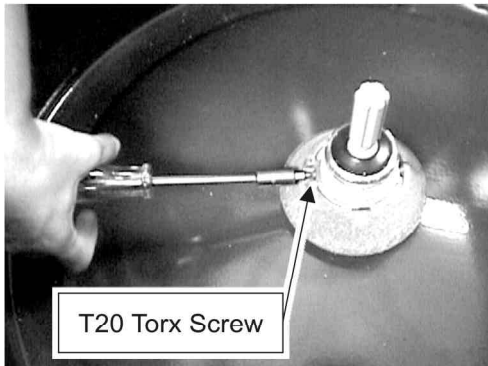

4. Use spanner wrench to remove Mounting Stem.

Note: This is a left hand thread so it must be turned clockwise. A mallet will be required to loosen.

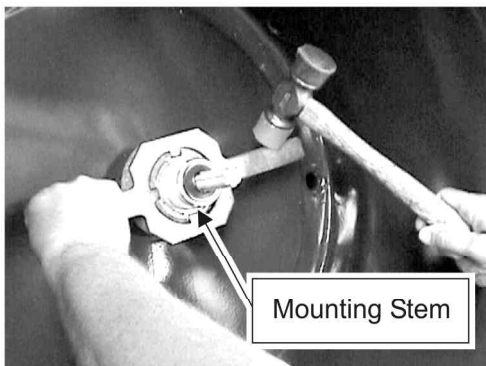

5. When the Mounting Stem is lifted off you have access to the Boot Seal.
6. Remove Boot Seal by twisting clock wise.

Reinstalling Mounting Stem

1. Center seal grease may be used on the mounting stem threads. When the Mounting Stem has been reinstalled and hand tighten to seat. Tap the spanner wrench a couple of times with the mallet to seat.
2. Before inserting the set screw into the Mounting stem, lubricate the hole in the mounting stem with Maytag grease. Be sure to tighten the screw securely.

Note: Set screw must not be in a water relief groove.

Outer Tub

1. Disconnect power supply to unit.
2. Remove Inner Tub.
3. Remove Mounting Stem.
4. Loosen clamps and remove Drain Hose and Air Dome Hose from Outer Tub.

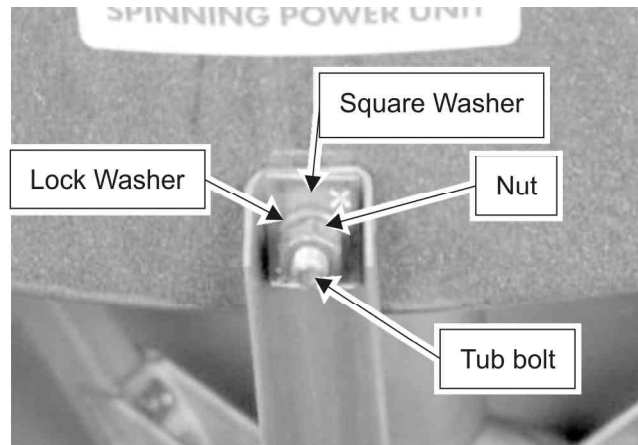

5. Remove three bolts that hold the Outer Tub to the tub braces. To facilitate removal of Tub Bolts, remove outside nuts, lock and Retaining Washers and push tub Bolts through into the Tub.
6. Lift Outer Tub off transmission.

Note: When replacing tub bolt and nuts, just get them started. Do not tighten them until you have the front bolt also started. Use the brake package tool, you can hook the front brace to apply pressure to move the brace against the tub. This makes it easier to get the lock washer and the nut on the front bolt.

Note: The two rear bolts are longer than the front bolt. DO NOT use a long tub bolt in the front position.

Tub Bearing

1. Disconnect power supply to unit.
2. Remove Outer Tub.
3. Because of the porcelain tub and molded retainer, it is not practical to drive the tub bearing from the tub. To remove the bearing from the tub, elevate the tub so that the porcelain drain tube clear the floor. This could be done by placing 2 X 4 under the tub.
4. Apply pressure on the bearing pushing it from the tub. This can be done by standing on the bearing.

Disassembly Procedures

WARNING

To avoid risk of electrical shock, personal injury or death; disconnect power to unit before servicing.

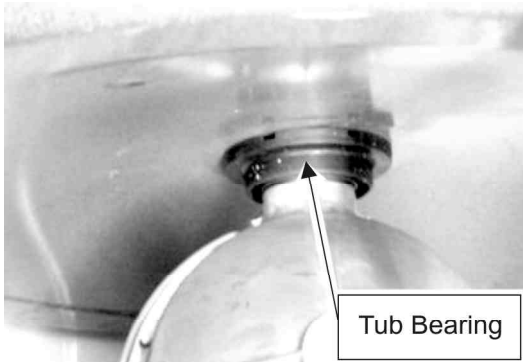

Reinstalling tub bearing

1. Turn tub over, starting bearing into outer tub.
- Note:** Caution should be exercised to see that the tub bearing is started into the tub straight to prevent egg-shaping when sealed in the tub.
2. Press bearing into place by apply pressure. This may be done with a rubber mallet.

Transmission

1. Disconnect power supply to unit.
 2. Remove Mounting Stem.
- Note:** Prior to Series 22, proceed onto Step 3.
- Note:** Beginning with Series 22, The Mounting Stem must be removed if work must be performed on Agitator shaft, before proceeding.
3. Place Tub Block in the Tub.
 4. Remove Front Panel.
 5. Lay the washer on its back and remove Belts.
 6. Place an oil catch pan (Motor Cover will do) under the center hub of the Transmission (take used oil to your local oil recycling center for proper disposal).
 7. Remove the 7/16" bolts from the transmission cover.
- Note:** Be sure the bolts heads are facing up. This will insure that you will not get oil all over the back of the washer should the cover come loose. Cut around the cover to separate silicon sealer used as a gasket.

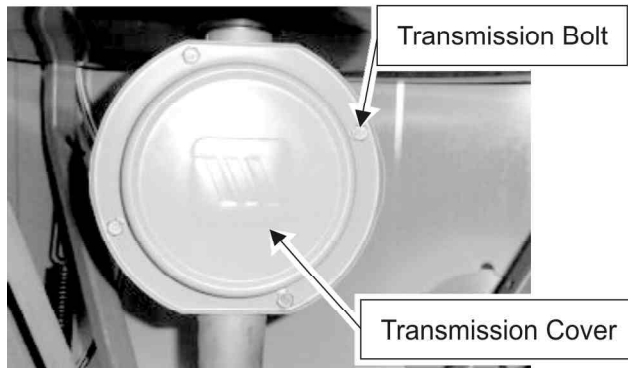

8. Remove cover plate (it may be necessary to pry the plate off with a screwdriver). Carefully rotate the transmission, dumping oil into your catch pan.
9. Remove Plastic Keeper on the top of the Agitator shaft.

Note: Prior to Series 22, a spring Retaining Clip was used. This clip can be removed by pulling it out and off the agitator shaft. Care should be taken when removing.

Note: Beginning with Series 22, a Plastic Keeper is used.

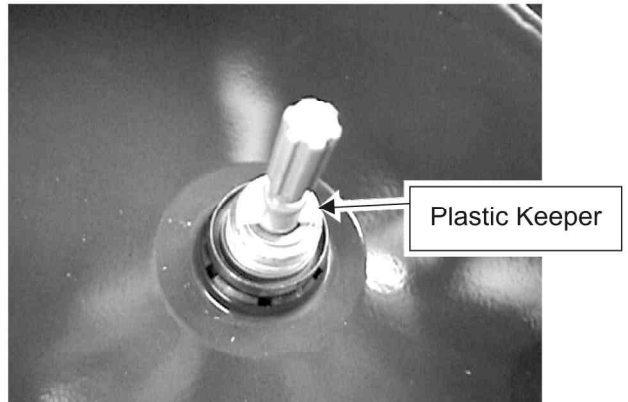

10. Remove the Plastic Keeper and Center Shaft Collar.

Note: Early models used a Collar secured with a Pin (remove with a 3/16" Allen wrench).

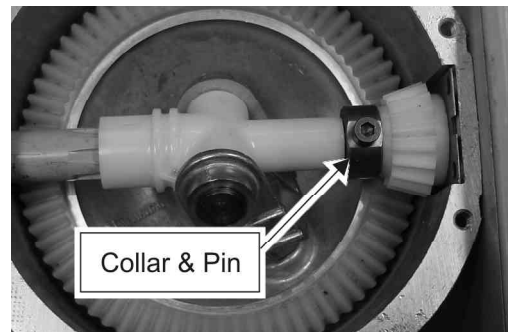

Note: Later version used the Plastic Keeper and Center Shaft collar

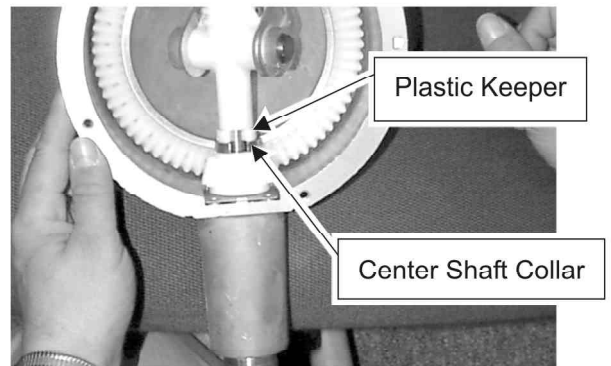

Disassembly Procedures



WARNING

To avoid risk of electrical shock, personal injury or death; disconnect power to unit before servicing.

11. Grasp the drive pulley and slowly pull the center shaft out. Only a small amount of force will be needed to remove the shaft.

Note: Be careful not to damage the Lip Seal at the bottom of the Transmission.

12. Pull the Agitator Shaft out through the Tub.

Note: You may have to pull hard on this as the oil in the Torque Block forms a suction.

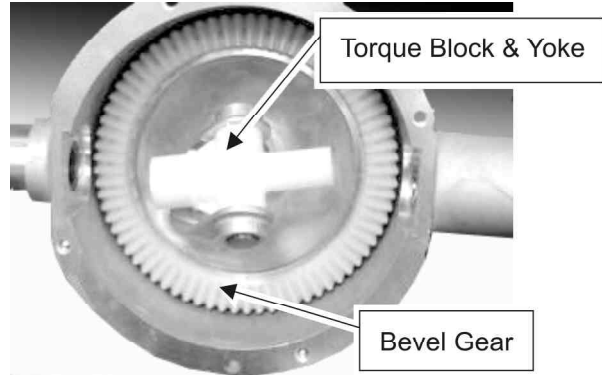
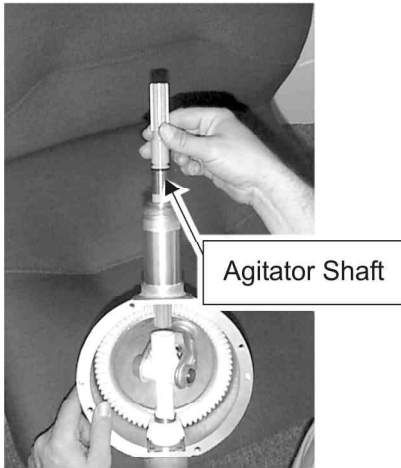

Note: At this point, all components to be reassembled should be cleaned. Also, clean any silastic from the Transmission housing and cover before reassembling. Apply a thin film of oil on the center stud before installing Bevel Gear.

Lip Seal

1. Disconnect power supply to unit.
2. Tip washer to gain access to bottom of pulley. Remove #2 Phillips screw and lock washer from bottom of Drive Shaft.
3. Pry drive Lug off Drive Shaft.
4. Spin drive Pulley off shaft (counterclockwise from bottom).

13. With the Agitator and Drive Shafts removed, simply lift out the Pinion Gear, followed by the steel Clutch Plate and copper Spined Washer which are located under the Pinion Gear.

Note: Pay close attention as to the order in which the Clutch Plate and Spline Washer are Removed.

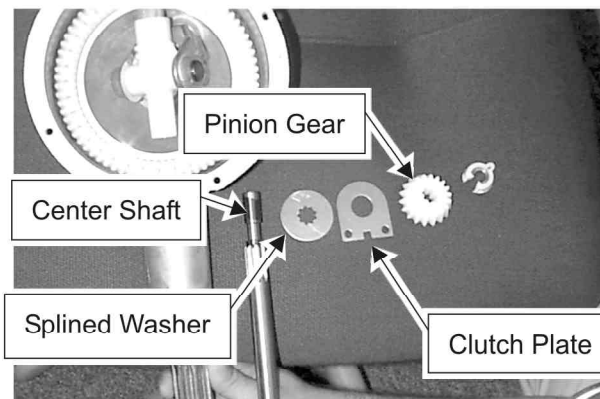

14. The Torque Block and Yoke can now be removed as can the Bevel Gear. Underneath the Bevel Gear is a spacer Washer.



5. Use the Lip Seal Tool to remove the Lip Seal from Center Tube.

Note: This tool is screwed into the Lip Seal and the Lip Seal is removed by turning the bolt against the Center shaft.

Reinstalling Lip Seal

1. Clean Lip Seal recess in the center tube with choke cleaner to remove any oil. Make sure area is clean and dry.
2. Press new Lip Seal over the Seal-Protector. The Seal-Protector is designed to protect the seal area of the Lip Seal from rolling over or tearing as the seal is

Disassembly Procedures

WARNING

To avoid risk of electrical shock, personal injury or death; disconnect power to unit before servicing.

- pressed into the center tube of the transmission.
3. Slide assembly over square thread of center shaft until the Lip Seal starts into the center tube bore.
4. Turn Drive Pulley onto the center shaft and against Seal -protector. Tighten pulley to press Lip Seal into / center tube bore. Back pulley off and check to make sure Lip Seal is pressed into position (flange of Lip Seal should be against end of center tube).
5. Remove Pulley.
6. Using the loops, remove Seal -Protector and discard.

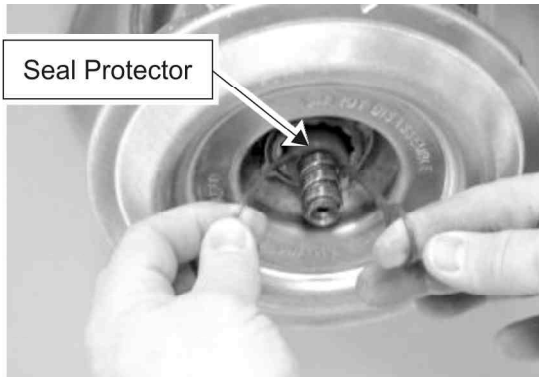

6. Set washer down on top of the wood block.
7. The complete assembly of the Tubs and Damper should be pushed up from the base far enough to get to the damper pads.
8. Scrape old pads from base.
9. Use a degreasing agent such as alcohol to remove any grease from the area.
10. Apply rubber adhesive to area where old pads were removed.
11. Apply pads to base and let dry. The top surface of the pad should be located 3/32" below center opening in base. The distance between pads should be about 5/8".

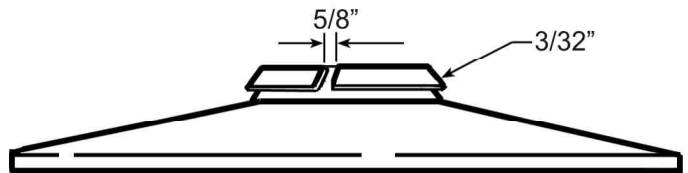

7. Replace pulley and belts. Be sure rotor bearing is on drive pulley correctly with "cup" of bearing over hub of pulley.
8. Place washer in upright Position. Replace front panel and remove tub block.

Note: Connect washer and check for proper operation.

Damper Assembly

1. Disconnect power supply to unit.
 2. Remove two bolts holding Top Cover and raise.
- Note:** Tape Lid to prevent it from striking the Control Panel.
3. Remove nut from three eyebolts. The position of the nuts on the eyebolts can be marked by placing strips of electrical tape around bolts above nuts before loosening.
 4. Remove Drive Belts.
 5. Tip washer back and lay 4" X 4" wood block under drive pulley.

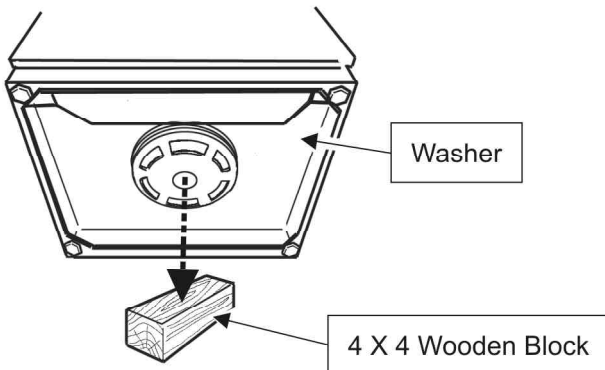

Brake Package and Radial Bearing

1. Disconnect power supply to unit.
2. Put Tub Block in Tub and lay washer back far enough to get to the Pulley and Brake Package.

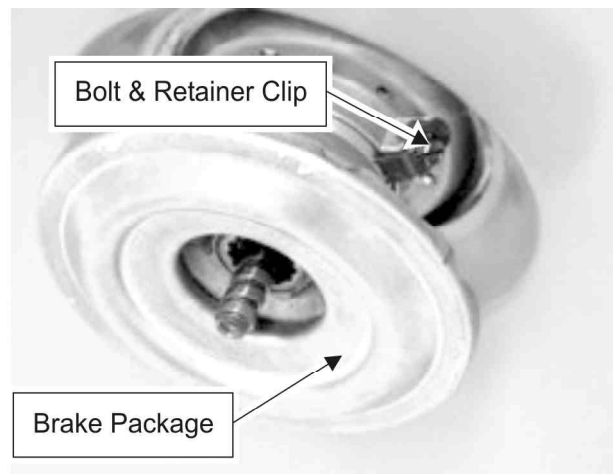

3. Remove Bolt and Retainer Clip in Damper holding the brake package.

Note: Bolt and Retainer Clip must be removed before the brake package.

Disassembly Procedures

WARNING

To avoid risk of electrical shock, personal injury or death; disconnect power to unit before servicing.

4. Use the Brake Tool to unscrew the Brake Package assembly from the Damper. When the Brake Package is free, pull to disengage it from the spline surface of the drive tube.

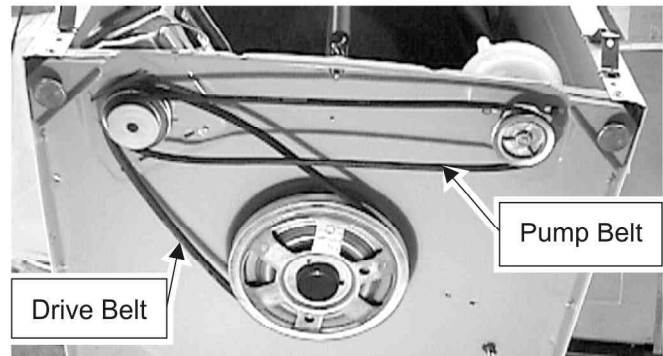

5. Use a hammer to remove the Brake Package.

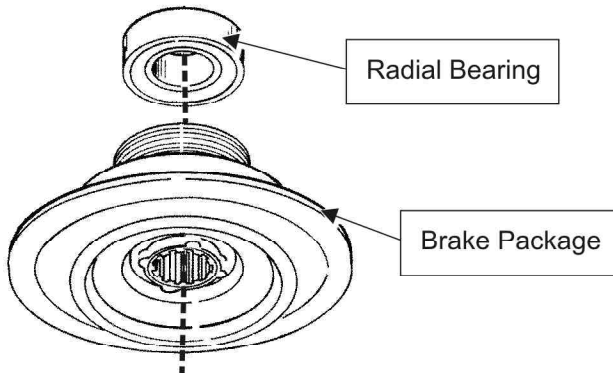

6. After Brake Package has been removed, the Radial Bearing may be removed from top of Brake package.

Drive Pulley and Rotor Bearing

1. Disconnect power supply to unit.
2. Remove Drive and Pump Belts and Dust Cap covering hub of Pulley.
3. Remove screw and washer from bottom of Drive Shaft.
4. Remove the splined Drive Lug from the Drive shaft.
5. Turn pulley counterclockwise to remove it from the Helical Shaft. The Rotor Bearing is located above the drive pulley.

Note: There is a top and bottom to the rotor bearing. When it is positioned correctly, the top of the Bearing and the Pulley hub will be about even (the concave side against Pulley hub).

WARNING

To reduce the risk of serious injury or death to persons when using your washer, make sure the Rotor Bearing is not put on upside down. You will have no Brake.

Belts

1. Disconnect power supply to unit.
2. Remove front Panel.
3. Tilt machine backwards.
4. Roll Pump Belt then Drive Belt off pulleys.

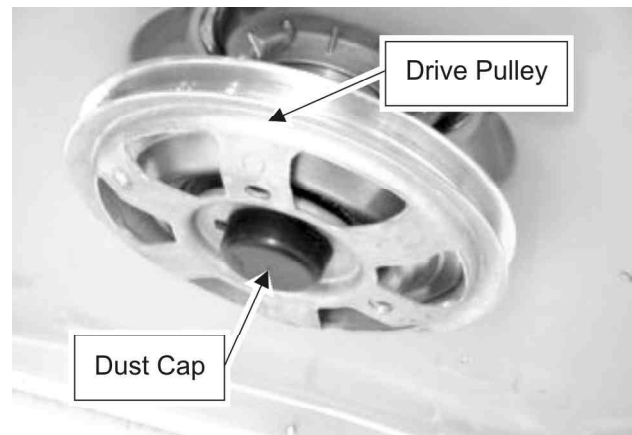

Note: When the drive Pulley is replaced, the Drive Lug must be properly positioned.

Disassembly Procedures



To avoid risk of electrical shock, personal injury or death; disconnect power to unit before servicing.

Pump

1. Disconnect power supply to unit.
2. Remove Front Panel.
3. Disconnect hoses from pump.

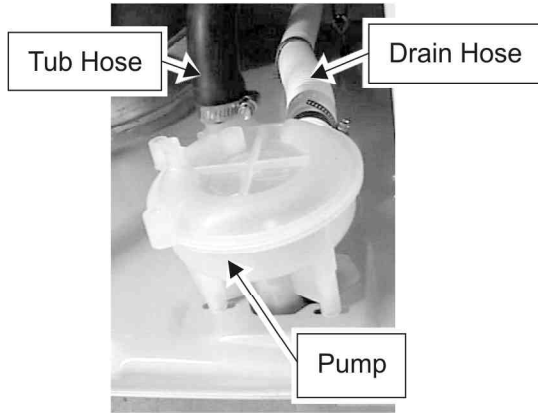

4. Tape washer lid to Top Cover.
5. Tilt washer and remove Pump Belt.
6. Remove three screws from bottom of base holding pump to base. The mounting holes for the pump on the base frame are slotted for adjustment of the Pump Belts.

Note: Mark the general position of pump before removing.

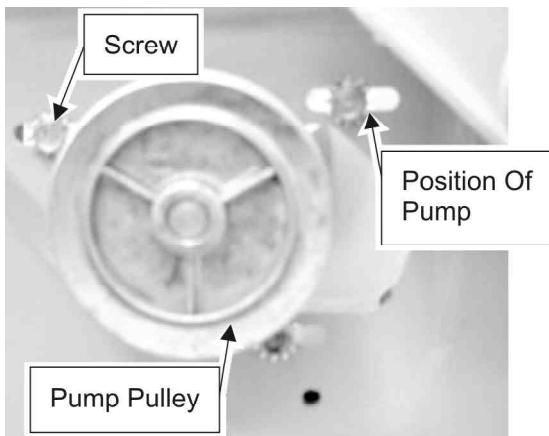

7. Tilt pump and lift through access hole in base frame.

Drive Motor and Motor Base

1. Disconnect power supply to unit.
2. Remove Front Panel.

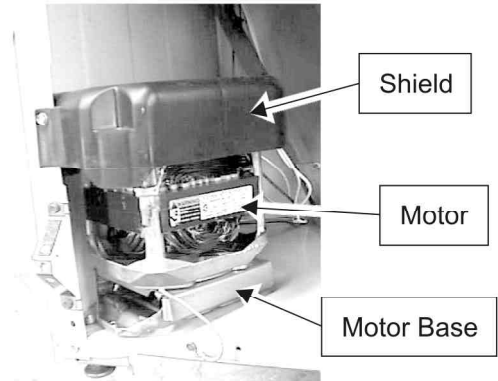

3. Remove Motor Cover.
4. Remove main wiring harness from motor terminals.

Note: DO NOT remove the wires going from motor switch to motor.

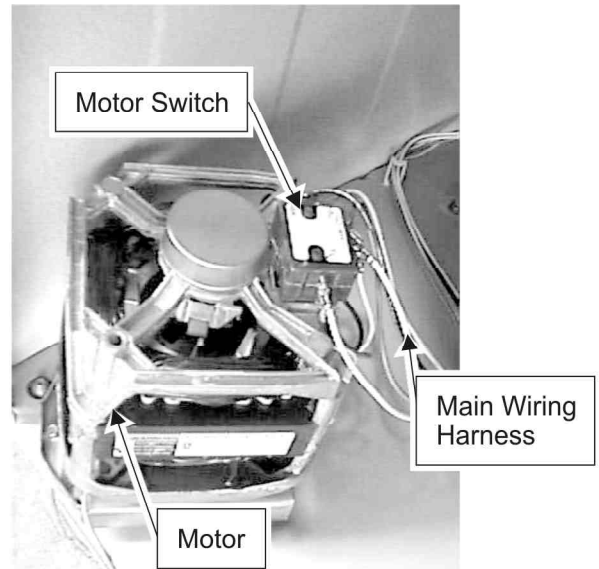

5. Remove Belts.
6. Remove three screws holding motor base to base frame.
7. Remove Motor and Motor Base.
8. Remove Pulley from Motor.
9. Disengage tension springs and remove mounting nuts.

Note: To remove two of the nuts, align upper and lower sections and insert wrench through the slots into lower section.

10. Lift Motor Base off Motor.

Note: With Motor removed, carriage and slides are accessible for service.