

SERVICE MANUAL

SERVICE MANUAL SECTION

CE 200 AND CE 300 BUS BODY COMPONENTS

Model: CE 200

Model: CE 300

S47004

08/18/2004

Table of Contents

1. IDENTIFICATION.....	1
1.1. VEHICLE CERTIFICATION PLATE.....	1
1.2. BODY SERIAL NUMBER.....	2
2. DESCRIPTION.....	3
2.1. VEHICLE EXTERIOR.....	3
2.2. REPORTING SAFETY DEFECTS.....	3
2.3. FRONT END.....	4
Crossing Control Gate.....	4
Cross View Mirrors.....	4
Hood and Related Components.....	5
2.4. BUS BODY — EXTERIOR.....	7
Windshield, and Windshield Wipers.....	7
Rear View Mirrors.....	7
Passenger Entry Door.....	9
Vandal Lock.....	11
Front Warning Lights.....	12
D.O.T. Lights and Reflectors.....	12
Assist Steps.....	13
Fuel Fill.....	14
Emergency Exit Doors.....	15
Emergency Exit Windows.....	16
Passenger Windows.....	16
Roof Mounted Escape Hatch.....	17
Rear Bumper Assembly.....	18
Rear Body Exterior Lights.....	19
Side Traffic Stop Arm.....	19
Under Body Compartments.....	21
Electrical Compartment.....	22
Battery Compartment.....	23
Radio Antenna.....	24
Chair Lift Door and Chair Lift.....	25
Roof Mounted Strobe Light (Optional).....	27
Transition Panels.....	28
End Caps.....	28
Windshield- 3 Piece.....	29
Driver Side Window.....	30
Driver Side Storm Glass Windows.....	31
Static Roof Vents.....	31
Mud Guards.....	31
Rear Wheel Rubber Fenderettes.....	31
Body Tie Down Bolts and Assemblies.....	31
2.5. BUS BODY — INTERIOR.....	32
Step Well.....	32
Assist Rails.....	33
Step Well Heater.....	34
Crash Barriers.....	34

Fire Extinguisher.....	35
Driver Controls / Instrument Panel.....	36
Driver Side Sliding Window.....	39
Driver Side Storm Window Assembly (Optional).....	39
Driver Seat.....	39
Heater and Defroster.....	41
Light Bars.....	42
Flooring.....	45
Seats and Seating.....	46
Windows.....	49
Emergency Exit Door Lower Glass Protection Screen.....	51
Emergency Exit Latches and Alarms.....	52
Exterior Light Monitor (Optional).....	53
Safety Equipment- Reflective Road Triangles.....	54
Seat Tracks.....	54
Wheelchair Access Door and Chair Lift.....	56
Wheelchair Access Door Assembly.....	61
Fuel Sender Access Panel.....	64
Miscellaneous Options.....	65
First Aid Kit.....	65
Body Fluid Clean-up Kit (Optional).....	65
Windshield Defroster Fan (Optional).....	66
Driver Side Interior Rear View Mirror and Sun Visor.....	67
Manual Door Opener.....	67
3. REMOVE.....	69
3.1. EXTERIOR BODY COMPONENT — REMOVE.....	69
Windshield Wiper Drive Arm Removal.....	69
Windshield Removal.....	71
Rear View Mirror- Driver Side.....	75
Rear View Mirror- Passenger Side.....	76
Front Warning Lights.....	77
Destination Sign Lighted (Optional).....	78
D.O.T. Lights and Reflectors.....	79
Vandal Lock.....	79
Assist Steps.....	81
Passenger Entry Door.....	82
Fuel Fill.....	83
Passenger Windows and Emergency Exit Windows.....	84
Emergency Exit Doors.....	84
Roof Mounted Escape Hatch.....	86
Wheelchair Access Door.....	88
Rear Bumper Assembly.....	89
Rear Body Exterior Lights and Warning Lights.....	91
Street Side Stop Signs.....	92
Rubber Fenderettes.....	94
Under Body Compartments.....	94
Electrical Compartment.....	96
Battery Compartment.....	97
Radio Antenna.....	98
Transition Panels.....	98
End Caps.....	99
Optional Warning Lights.....	100

Body Attachment.....	100
Static Roof Vents.....	105
Mud Guards.....	106
3.2. INTERIOR BODY COMPONENTS — REMOVE.....	106
Step Well Tread Plates.....	106
Step Well Assembly-Removal.....	107
Assist Handrails.....	108
Defroster Fans (Optional).....	109
Sun Visor.....	109
Destination Board Lights (Optional).....	110
Interior Rear View Mirror.....	111
Dash Board Panels, Cluster and Switch Panels.....	111
Driver Side Sliding Window Assembly.....	116
Driver Seat.....	117
Driver Seat Belts.....	118
Fire Extinguisher.....	120
Driver Seat Bulkhead / Passenger Crash Barrier.....	120
Passenger Door Control Panel— Electric.....	121
Passenger Door Removal.....	124
Air Operated Door Opener (Optional).....	125
Bus Interior Light Bars.....	125
Seats and Seating Removal.....	126
Seat Tracks (Optional).....	129
Seat Belts— Two Point (Optional).....	130
Passenger Windows.....	131
Emergency Window Exits.....	132
Stationary Glass Removal.....	132
Emergency Window Exit Alarms.....	133
Emergency Exit Doors, Buzzers and Latches.....	134
Wheelchair Lift (Optional).....	137
Wheelchair Floor Plates.....	138
Wheelchair Seat Belts and Shoulder Harness.....	138
Rear Door Glass Protection Screen.....	139
Safety Equipment — Required.....	139
Safety Equipment — Optional.....	140
Exterior Light Monitor.....	140
Fuel Sender Access Hatch.....	141
Flooring.....	142
Plywood Sub-Flooring.....	142
4. INSTALL.....	143
4.1. EXTERIOR BODY COMPONENTS.....	143
Windshield Wiper Install.....	143
Windshield Install.....	144
Driver Side Rear View Mirror.....	151
Passenger Side Rear View Mirror.....	151
Front Warning Lights.....	152
Destination Sign.....	152
D.O.T. Lights and Reflectors.....	153
Vandal Lock.....	153
Assist Steps.....	154
Passenger Entry Door.....	155
Fuel Fill Door.....	155

Passenger Windows.....	155
Emergency Exit Windows.....	155
Emergency Exit Doors and Latches.....	155
Roof Mounted Escape Hatch.....	156
Wheel Chair Access Door.....	157
Rear Bumper Assembly.....	158
Rear Body Exterior Lights and Warning Lights.....	159
Street Side Body Stop Signs.....	159
Rubber Fenderettes.....	159
Under Body Compartments.....	160
Electrical Compartment Door.....	160
Battery Compartment.....	161
Radio Antenna.....	162
Driver Side Sliding Window.....	162
Driver Side Storm Window (Optional).....	162
Transition Panels.....	162
End Caps.....	163
Static Roof Vents.....	164
Optional Roof Mounted Warning Lights.....	164
Body Attachments or Tie Downs.....	165
4.2. INTERIOR INSTALL.....	165
Step Well.....	165
Assist Handrails.....	166
Defroster Fans (Optional).....	167
Sun Visor.....	167
Destination Sign Lights (Optional).....	167
Interior Rear View Mirror.....	167
Dash Board Panels, Cluster and Switch Panels.....	168
Driver Seat.....	169
Driver Seat Belts (3-Pt Belt Install).....	170
Driver Crash Barrier (Rail Mounted).....	170
Fire Extinguisher.....	172
First Aid Kit.....	173
Body Fluid Clean-up Kit (Optional).....	174
Passenger Door Control Mechanism.....	174
Bus Interior Light Bars.....	178
Seats.....	179
Seat Cushions.....	180
Seat Back.....	181
Seat Tracks (Optional).....	182
Seat Belt— 2 Point With Seat Track (Optional).....	183
Passenger Window Installation.....	183
Stationary Glass Install.....	184
Emergency Exit Window Installation.....	185
Emergency Exit Doors and Latches.....	185
Emergency Roof Hatch Exit Install.....	186
WheelChair Access Door (Optional).....	186
Wheelchair Lift.....	187
Wheelchair Floor Plates.....	187
Wheelchair Seat Belts and Shoulder Harness.....	187
Emergency Door Glass Protection Screen (Optional).....	187
Emergency Door and Wheelchair Access Door Glass Install.....	187
Safety Equipment (Required).....	188

Exterior Light Monitor (Optional).....	189
Fuel Sender Access Panel.....	190
Flooring.....	191
5. MAINTENANCE.....	192
5.1. HEATERS AND ACCESSORIES.....	192
Driver Side Heater.....	192
Step Well Heater (Optional).....	193
Under Seat Heaters.....	194
Rear Body Heaters (Optional).....	195
Maintenance.....	195
Heaters and Accessories.....	195
Troubleshooting.....	196
Heater / Defroster and Blower Motor Access Procedures.....	197
Access Main Front Heater / Defroster Blower Motors and Resistors Assembly.....	197
Auxiliary / Midship Heater Motor Access.....	198
Optional Step Well Heater Assembly.....	199
Troubleshooting Chart.....	202
Fluid Capacity.....	203
Upholstery Care and Cleaning Recommendations.....	203
6. EXTERIOR BODY REPAIR	204
6.1. REMOVE.....	204
Fasteners.....	204
Body Panel Remove.....	204
End Cap Remove.....	204
6.2. INSTALL.....	205
Rivet Replacement.....	205
Body Panel — Install.....	205
End Cap Replacement.....	205
7. WINDSHIELD WIPER DRIVE SYSTEM.....	206
7.1. WINDSHIELD WIPER MOTOR— REMOVE.....	206
8. PAINT AND FINISH.....	208
8.1. TOUCH UP AND PAINT PROCEDURE.....	209
9. LETTERING AND DECALS.....	209
9.1. SURFACE PREPARATION.....	209
10. CHARTS AND TABLES.....	211
10.1. COMPONENT INSPECTION INTERVALS.....	211
10.2. TORQUE CHARTS.....	213

1. IDENTIFICATION

1.1. VEHICLE CERTIFICATION PLATE

The certification plate is located on the left front bulkhead above the driver position. These plates should be referred to for identification of model number, parts order number and axle rating capacity. Whenever contact is made with a distributor or authorized service center, refer to these plates.

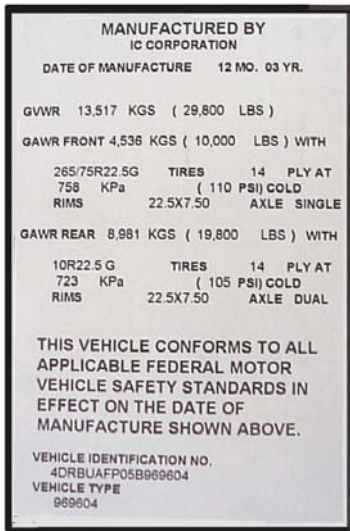

Figure 1 Certification Plate

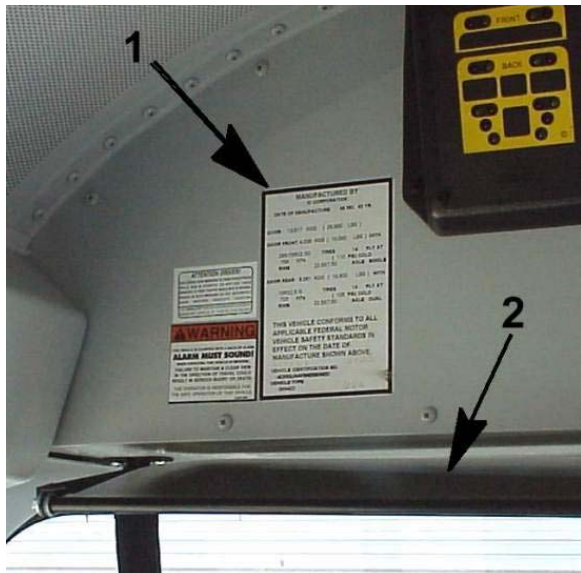

Figure 2 Certification Plate Location

1. CERTIFICATION PLATE
2. DRIVER SUN VISOR

1.2. BODY SERIAL NUMBER

The body serial number plate is located on the right side (curb side) of the bus above the front window light bar.

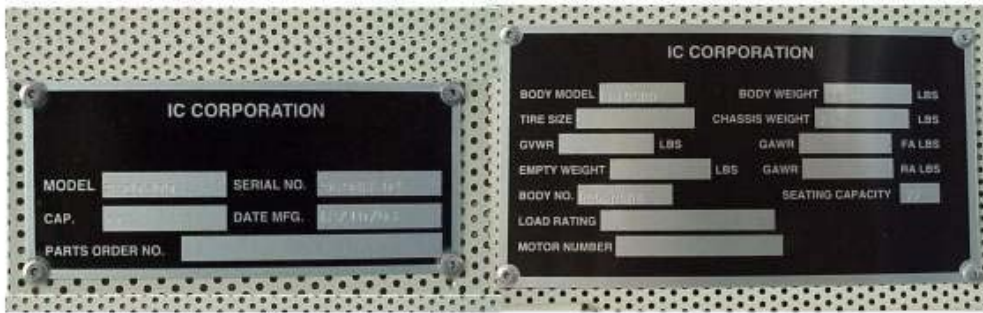

Figure 3 Body Serial Number Plate

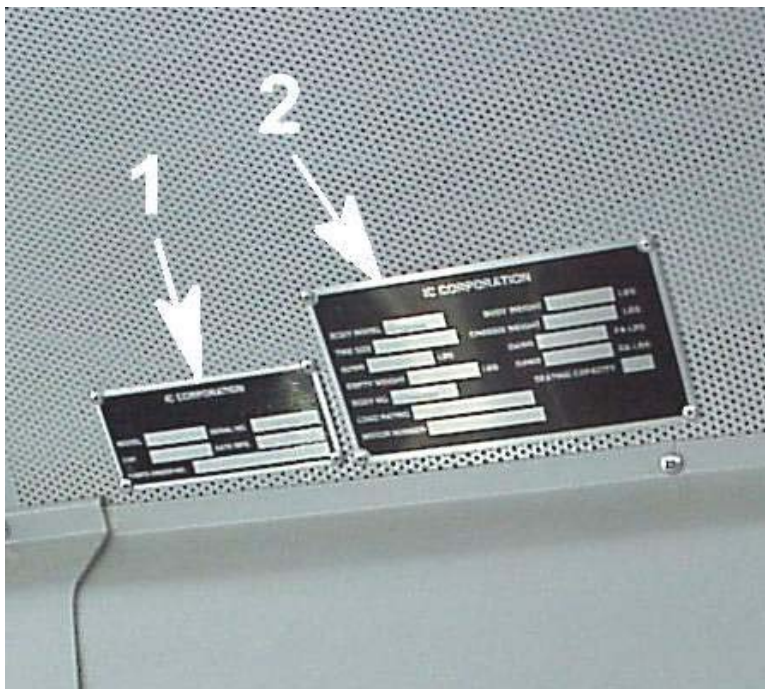

Figure 4 Body Serial Number Plate Location

- 1. BODY SERIAL NUMBER
- 2. CHASSIS SERIAL NUMBER PLATE

2. DESCRIPTION

2.1. VEHICLE EXTERIOR

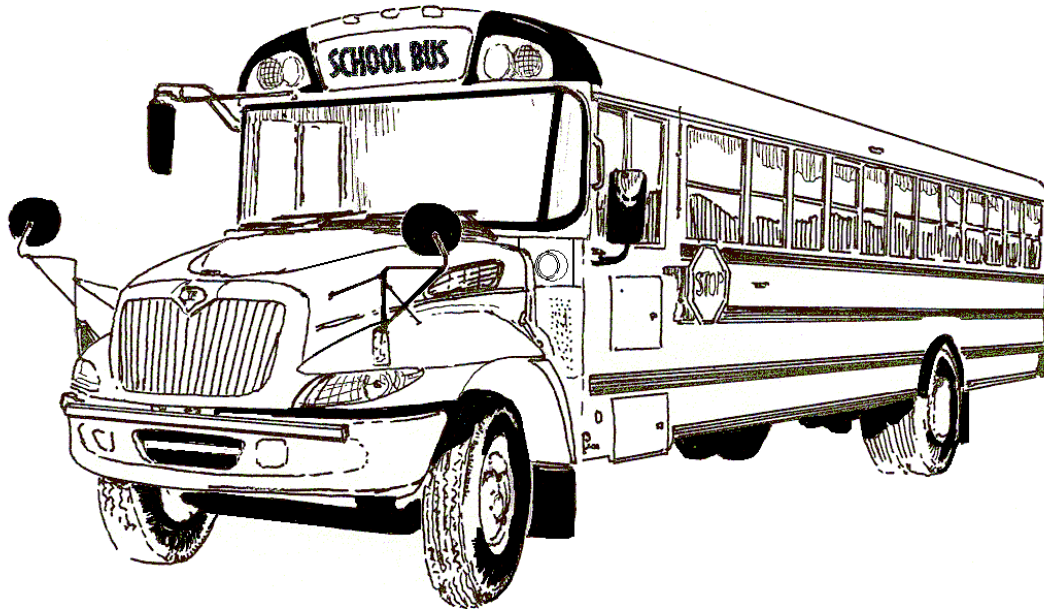

Figure 5 CE Series Bus

The CE 200 and CE 300 bus bodies are designed as a unit, which means that every structural part is tied to other structural parts to form a whole. This concept is known as unit body construction. The strength and durability of the bus body depends on the structural integrity of the unit. If any structural part is damaged or removed, the entire bus body integrity is weakened. Therefore, a damaged structural part must be carefully repaired or replaced exactly as it was originally so body strength can be restored. All units are to meet all applicable F.M.V.S.S. requirements as of the date of manufacture. The **floor** of the bus is designed as the foundation upon which the rest of the body is constructed. If the floor is ever twisted or damaged (other than superficial or cosmetic damage) it cannot be repaired, and the bus must be removed from service.

2.2. REPORTING SAFETY DEFECTS

If you believe that your vehicle has a defect that could cause an accident, injury or death, you should immediately inform the National Highway Traffic Safety Administration (NHTSA), in addition to notifying International Truck and Engine Corporation.

If NHTSA receives similar complaints, it may open an investigation, and if it finds that a safety defect exists in a group of vehicles, it may order a recall and remedy campaign. However, NHTSA cannot get involved in individual problems between you, your dealer or International truck and Engine Corporation.

To contact NHTSA, you may either call the Auto Safety Hotline toll-free at 1-800-424-9393 (or 366-0123) in the Washington D.C. area, or write to:

U.S. Department of Transportation

Washington, D.C. 20590

2.3. FRONT END

The front end components are listed in more descriptive detail in the Hood, Fender and Grille Service Manual. Refer to S09009 for detail instructions for serviceability of the various front end components.

Crossing Control Gate

The Crossing Control gate (Figure 6 Item 1) is a standard component on the CE Series bus. The gate is activated by the door opening mechanism and bus warning lights.

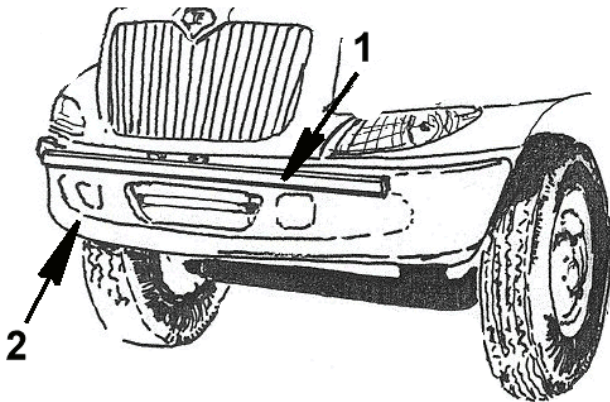

Figure 6 Crossing Control Gate and Front Bumper

1. CROSSING CONTROL GATE
2. FRONT BUMPER ASSEMBLY

Cross View Mirrors

The Cross View Mirrors are also a standard feature on the CE Series school bus. These mirrors allow cross frontal views of the students' activity at the front and sides of the bus entrance.

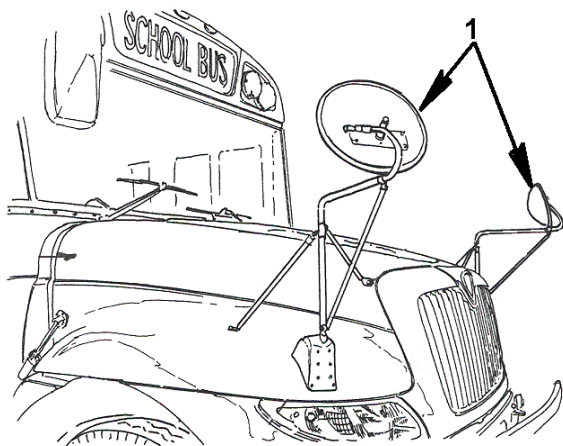

Figure 7 Cross View Mirrors

1. TYPICAL CROSS VIEW MIRROR ASSEMBLIES

Hood and Related Components

The hood and related components are more specifically described in the Hood, Fender and Grille Service Manual (S09009). The front end components are designed to enhance the overall safety and functionality of the entire school bus.

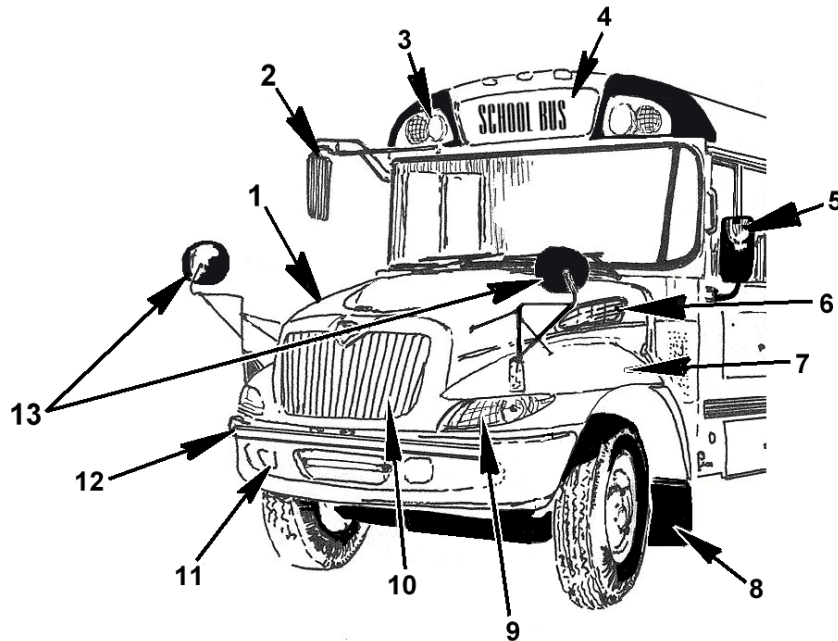

Figure 8 Front End

1. FRONT HOOD ASSEMBLY
2. PASSENGER SIDE EXTERIOR MOUNTED REAR VIEW MIRROR
3. SCHOOL BUS FRONT WARNING LIGHTS
4. FRONT SCHOOL BUS IDENTIFICATION PANEL
5. DRIVERS SIDE EXTERIOR MOUNTED REAR VIEW MIRROR
6. ENGINE AIR INLET ASSEMBLY
7. FRONT FENDER ASSEMBLY
8. FRONT WHEEL MUD FLAPS
9. HEADLIGHT AND DIRECTIONAL ASSEMBLY
10. GRILLE AND SHROUD ASSEMBLY
11. FRONT BUMPER ASSEMBLY WITH SAFETY GATE
12. SAFETY GATE
13. CROSS VIEW MIRRORS

2.4. BUS BODY — EXTERIOR

Windshield, and Windshield Wipers

The CE Series school bus utilizes a large three piece windshield assembly allowing the driver a full unobstructed field of view. The windshield wipers are designed to allow for the largest windshield cleaning area available on the conventional class school bus in the industry. The wiper pattern allows for a larger field of vision during inclement weather operation.

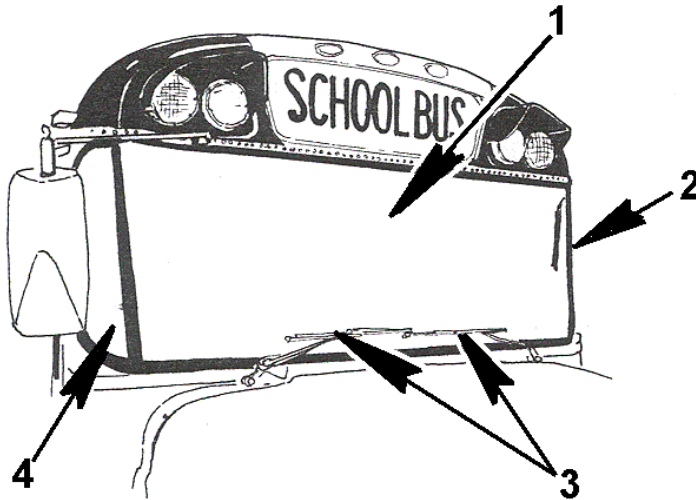

Figure 9 Windshield and Windshield Wipers

1. WINDSHIELD CENTER GLASS
2. DRIVER SIDE WING PANEL
3. WINDSHIELD WIPER ASSEMBLIES
4. PASSENGER SIDE WING PANEL

Rear View Mirrors

The driver side exterior rear view mirrors are located forward of the driver side window and are mounted on break-away brackets. The mirror is a dual head mirror with an adjustable convex and rear view flat section.

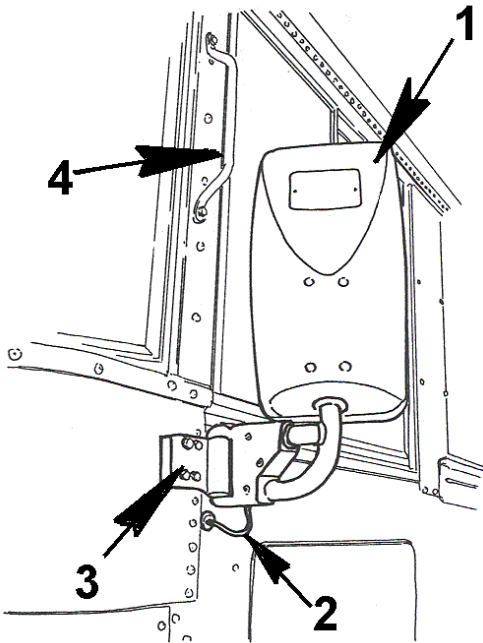

Figure 10 Rear View Mirror (Driver Side)

1. DRIVER SIDE REAR VIEW MIRROR ASSEMBLY
2. OPTIONAL HARNESS CONNECTION FOR HEATED MIRROR
3. MIRROR MOUNTING BRACKET
4. DRIVERS SIDE ASSIST GRAB HANDLE

The passenger side mounted rear view mirror assembly is mounted on a break away bracket forward of the entrance door with both convex and flat mirror heads. The mirror is situated forward of the bus body structure to allow for maximum visibility by the driver.

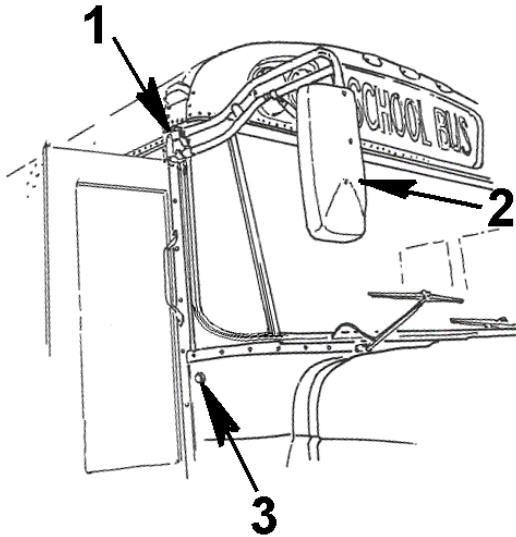

Figure 11 Rear View Mirror (Passenger Side)

1. PASSENGER SIDE REAR VIEW MIRROR MOUNTING BRACKET
2. PASSENGER SIDE REAR VIEW MIRROR HEAD ASSEMBLY
3. VANDAL LOCK

Passenger Entry Door

The passenger side entry doors are aluminum structured door assemblies utilizing increased height and through door visibility with larger functional glass areas. The door are electrically operated by the driver switch located in the steering wheel control panels. An emergency override switch is located on the overhead panel above the entry door. The passenger door assembly is also available as an air activated assembly. The air actuated override switch is located on the drivers right wing panel.

NOTE – The electric operated door opener has no speed adjustment control but limit switches can adjust the door opening limits.

NOTE – The air operated passenger door opening speed may be adjusted to allow for open and closing cycle times. The door mechanism is located above the entry door header and has a manual override.

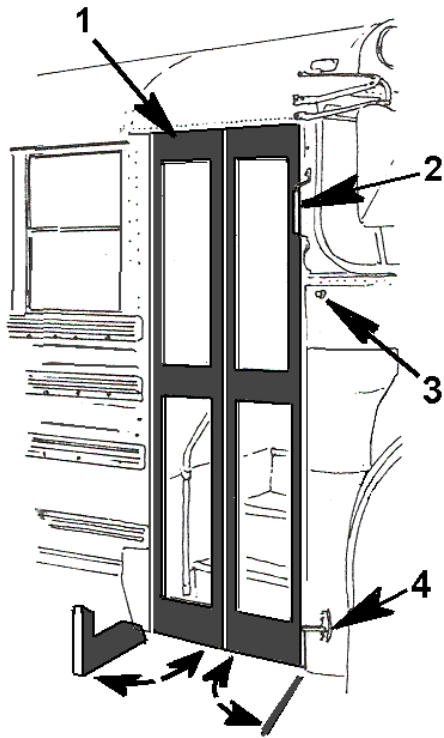

Figure 12 Passenger Side Entry Doors

1. PASSENGER SIDE ENTRY DOORS
2. PASSENGER SIDE DRIVER ASSIST GRAB HANDLE (MAINTENANCE PURPOSES ONLY)
3. VANDAL LOCK DOOR SWITCH
4. PASSENGER SIDE ASSIST STEP

Vandal Lock

The Vandal Lock option allows the driver to close and lock the passenger side entry door when the school bus is parked and not in operation or is intended to restrict access to the bus without the driver being present. The vandal lock is located on the passenger side of the bus forward of the side entry door above the transition panel and below the passenger side wing panel window.

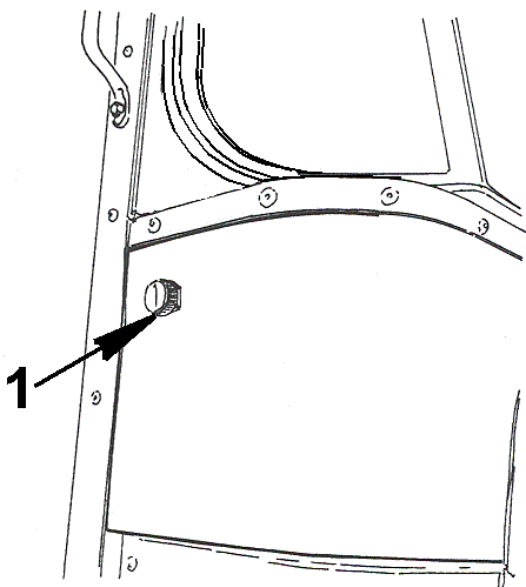

Figure 13 Vandal Lock

1. VANDAL LOCK ASSEMBLY

Front Warning Lights

The CE Series school bus is equipped with various warning light options as may required by both federal and state standards. The warning lights front and rear may also vary based on the requirements of the local school districts.

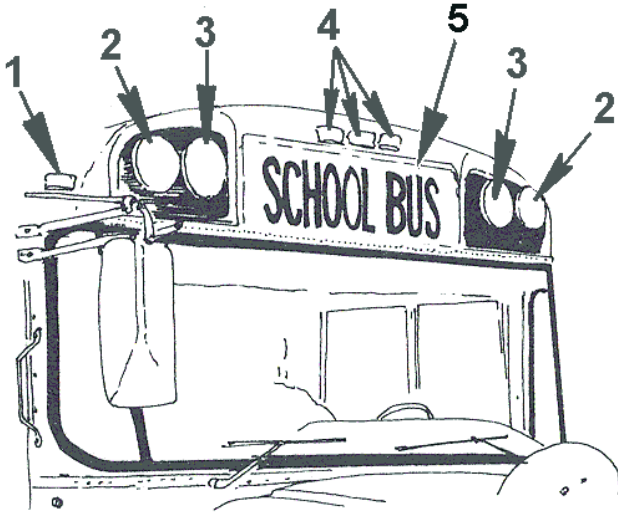

Figure 14 Front Warning and Clearance Lights

1. SIDE MARKER LIGHT (FEDERAL REQUIREMENT)
2. AMBER FLASHING WARNING LIGHT (AS REQUIRED)
3. RED FLASHING WARNING LIGHT (AS REQUIRED)
4. AMBER CLEARANCE LIGHTS (FEDERAL STANDARD)
5. IDENTIFICATION / DESTINATION SIGN (MAY BE LIGHTED)

D.O.T. Lights and Reflectors

Federally mandated reflectors and clearance lights are located according to F.M.V.S.S. standards. The reflectors, depending on location, may be red or amber in color.

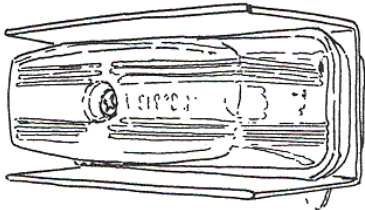

Figure 15 D.O.T. Lights (Side mounted on body)

Assist Steps

Driver fold down assist steps are located each side of the body on the lower cowl assembly to assist in accessing the windshield or wipers for cleaning, servicing or adjustment. Grab handles (Fig. 10, Item 4 and Fig. 12, Item 2) are also installed each side of the bus exterior to assist in accessing the windshield area and wiper assemblies.

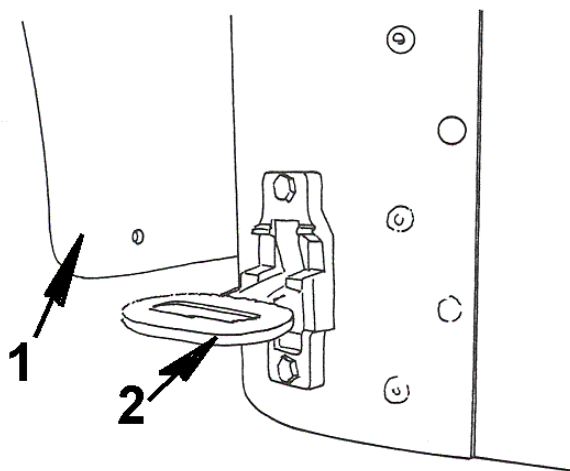

Figure 16 Assist Steps (Driver Side Shown)

1. FENDER EXTENSION
2. ASSIST STEP

Fuel Fill

The CE series bus fuel fill assembly is located on the passenger side of the bus body. The fuel fill may be located at the forward section passenger side of the bus (Fig. 17 Item 3), aft of the side entry door on buses equipped with side frame rail mounted fuel tanks. The fuel tank and fuel fill may be located on the driver side of the bus. Access to the fuel filler assembly may require a key if fuel fill door is of the locking type. Buses with fuel tanks located aft the rear axle and between the frame rails have the fuel fill located on the passenger side of the body behind the rear wheel well openings. A spring hinged fuel fill door with or without lock or latching mechanisms are utilized on the fuel fill access doors.

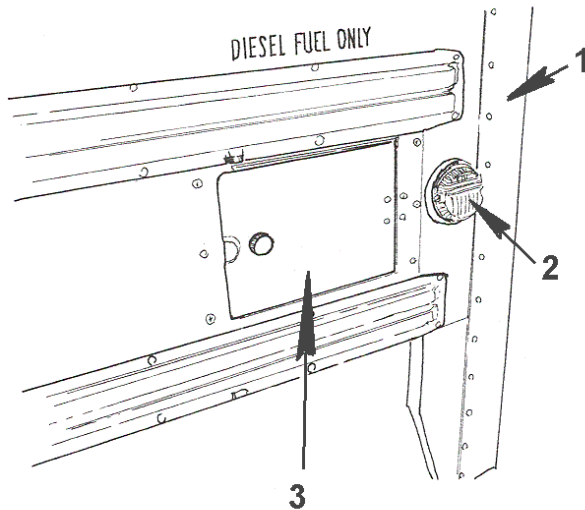

Figure 17 Fuel Fill Door (Bus With Frame Rail Mounted Fuel Tank Shown)

1. PASSENGER SIDE ENTRY DOOR REAR FRAME
2. OPTIONAL SIDE ENTRY ACCESS LIGHT
3. FUEL FILL DOOR

Emergency Exit Doors

The CE Series school bus is equipped with emergency escape exits as required by state and federal law. The school bus must be equipped with one emergency escape door located at the rear (Fig. 18) or mid ship section of the school bus, depending on the number of occupants and/or state requirements. The school bus is also equipped with emergency escape push-out or kick-out windows; location and number are per requirement of state or local mandates. Roof mounted escape hatches may also be provided for bus egress in a roll-over situation. The CE school bus is equipped with recessed hidden hinge assemblies at the rear and side emergency doors. All emergency exits are equipped with an open door alarm activation switch to alert the driver of any emergency door which might be ajar.

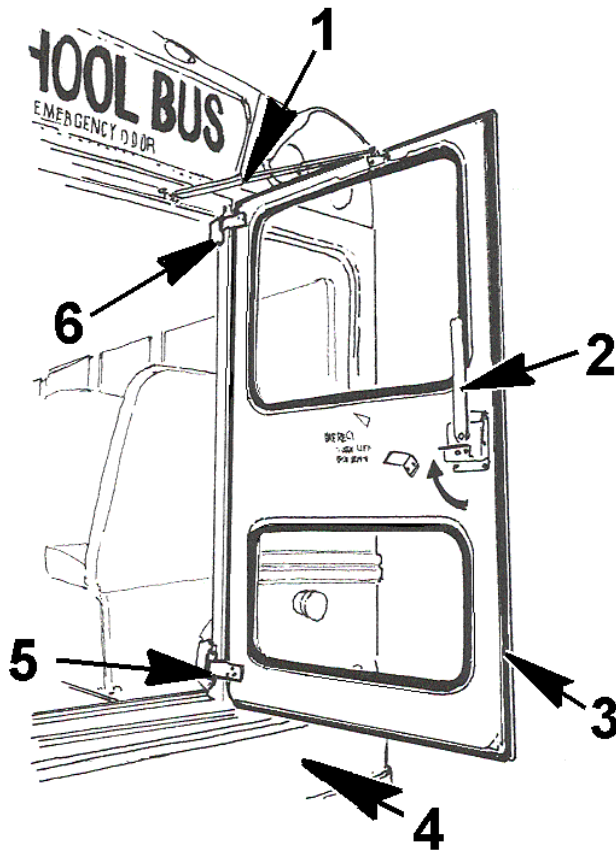

Figure 18 Emergency Exit Door (Rear Door Exit Shown)

1. EMERGENCY EXIT DOOR STAY ASSEMBLY
2. EMERGENCY DOOR EXIT LIFT BAR
3. EMERGENCY EXIT DOOR
4. REAR BUMPER ASSEMBLY
5. LOWER EMERGENCY EXIT DOOR RECESSED HINGE ASSEMBLY
6. UPPER EMERGENCY EXIT DOOR RECESSED HINGE ASSEMBLY

Emergency Exit Windows

Emergency exit push-out or kick-out windows (Fig. 19, Item 2) are located each side of the bus as required by individual state requirements. The number and location of the emergency escape windows is subject to the state or local mandates. Emergency escape windows may come in different configurations as required by the state requirements. The windows may latch and kick-out with a bottom mounted latch or swing out vertically with a vertically mounted latch. All emergency windows are equipped with a relay alarm switch that activates when the latch mechanism is opened. This will alert the driver of any open emergency windows.

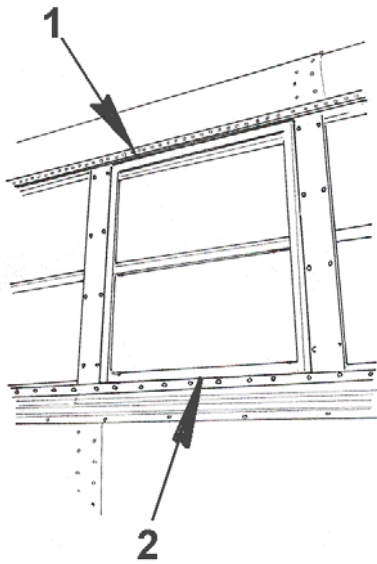

Figure 19 Emergency Exit, Bottom Push— Out Windows Shown (Exterior View)

1. PASSENGER WINDOW ASSEMBLY
2. KICK-OUT WINDOW WITH LOCKING INTERIOR LATCH

Passenger Windows

The CE Series school buses are equipped with aluminum extruded framed passenger windows. All windows are top opening with dual closure latches at the top of the upper window frame assembly. The bus passenger windows are removable for glass replacement and/or other repairs.

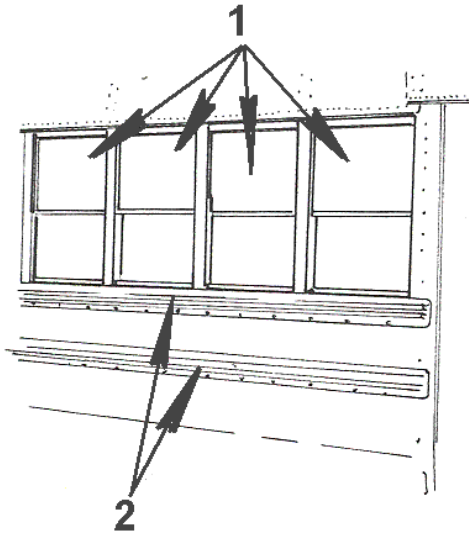

Figure 20 Passenger Windows

1. STANDARD PASSENGER SIDE WINDOWS
2. RUB RAILS

Roof Mounted Escape Hatch

The roof mounted escape hatch allows egress from the bus body through the roof section in the event of an emergency where exiting the emergency exit doors or windows is not possible (Fig. 21, Item 3).

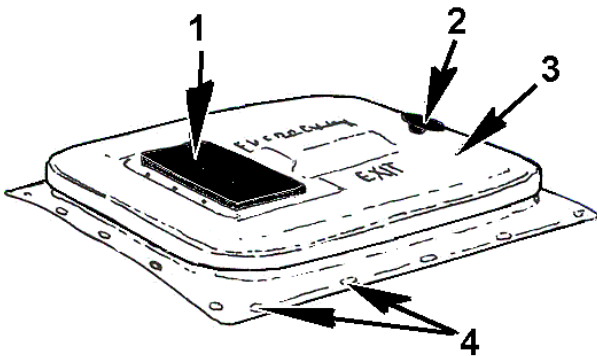

Figure 21 Roof Emergency Escape Hatch

1. STATIC ROOF VENT (OPTIONAL)
2. EXTERNAL HATCH LATCH
3. ESCAPE HATCH
4. MOUNTING RIVETS WITH CAPS (AROUND PERIMETER)

Rear Bumper Assembly

The rear bumper assembly is a full wrap around style bumper bolted to the chassis frame assembly. The optional tow hooks are also mounted to the frame assembly and are located below the bumper assembly (Fig. 22, Item 4) at the rear of the bus.

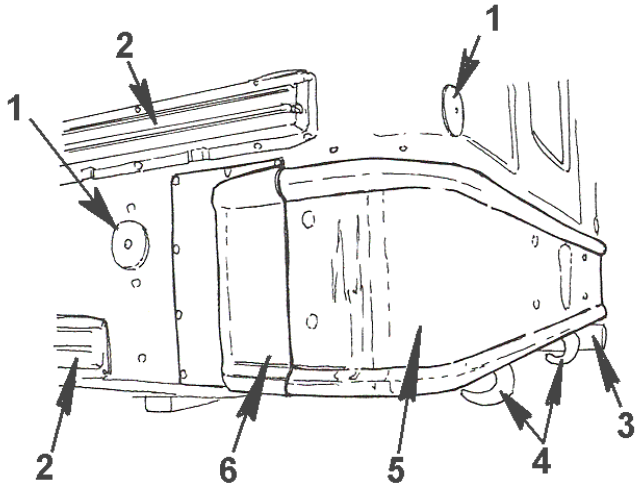

Figure 22 Rear Bumper Assembly and Tow Hooks

1. D.O.T. RED REFLECTOR
2. BODY SIDE RUB RAIL
3. EXHAUST PIPE
4. REAR TOW HOOKS
5. BUMPER ASSEMBLY
6. REAR BUMPER TRANSITION PANELS

Rear Body Exterior Lights

The lower rear body lights include all requirements of F.M.V.S.S. with options that may be required by the local state or regional authority.

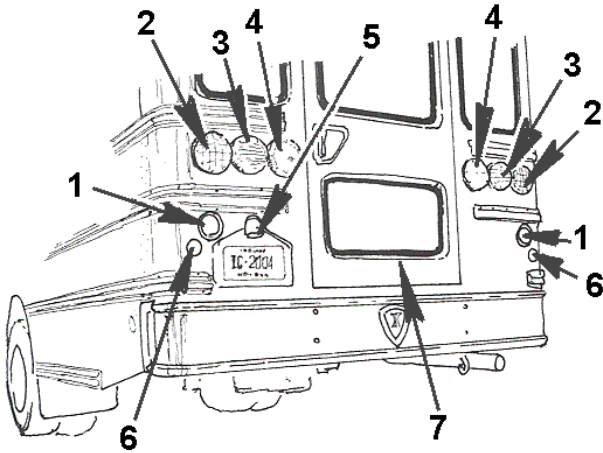

Figure 23 Rear Bus Lights (Lower Lights)

1. RED REAR BODY LIGHTS (OPTIONAL)
2. AMBER DIRECTIONAL LIGHTS
3. RED STOP / TAIL LIGHTS
4. CLEAR BACK-UP LIGHTS (SIZES OF LIGHT ARE OPTIONAL)
5. LICENSE PLATE LIGHT AND HOLDER
6. RED D.O.T. REFLECTORS
7. BUS REAR EMERGENCY EXIT DOOR

Side Traffic Stop Arm

Driver side stop arm signs are located at the forward portion of the bus body under the driver side window. These signs are electrically or air operated with flashing warning lights facing forward with a large reflective stop sign. The warning lights on the safety arm may vary in the type of lights required by the local district or state standard. An Optional air operated safety arm is available.

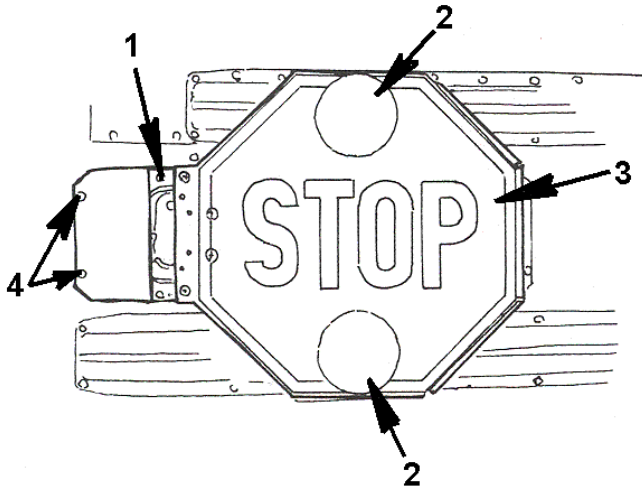

Figure 24 Standard Stop Sign and Light

1. SIGN HINGE BRACKET
2. RED FLASHING WARNING LIGHTS (LIGHT TYPE MAY VARY)
3. REFLECTIVE STOP SIGN FACE
4. STOP ARM FORWARD MOUNTING BOLTS

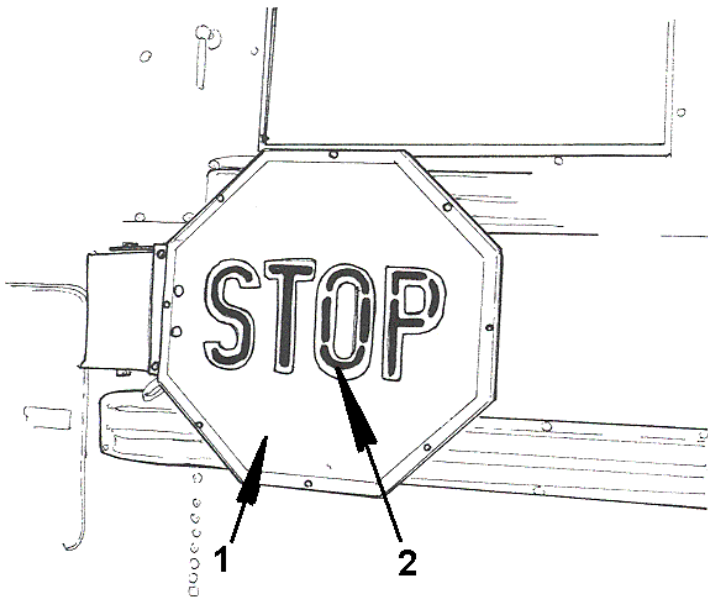

Figure 25 Optional L.E.D. Side Stop Sign

1. STOP ARM REFLECTIVE STOP SIGN FACE
2. L.E.D. RED FLASHING LETTERS

An optional rear stop arm may be specified (Fig. 26). This stop arm is located on the rear street side of the bus body with the warning light and sign face facing the rear of the bus when activated.

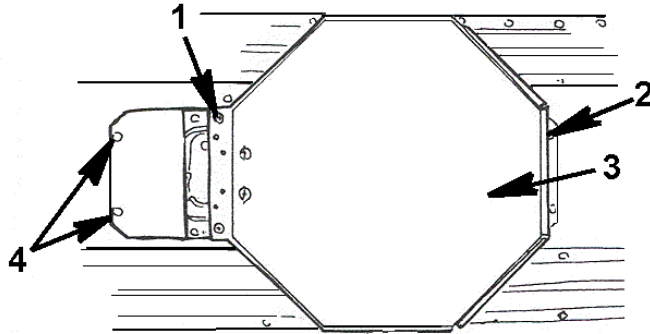

Figure 26 Side Rear Stop Sign and Light

1. STOP ARM HINGE MOUNTING SCREWS
2. STOP ARM ASSEMBLY REAR MOUNTING SCREWS
3. SIGN FACE BACK SURFACE
4. STOP ARM ASSEMBLY FRONT MOUNTING SCREWS

Under Body Compartments

Additional compartments under the bus body is available on either side of the bus, depending on the size and location of the fuel tank. These compartments vary in size and type of door hardware. Compartments may be equipped with horizontal hinges or vertical depending on the style and size compartment chosen.

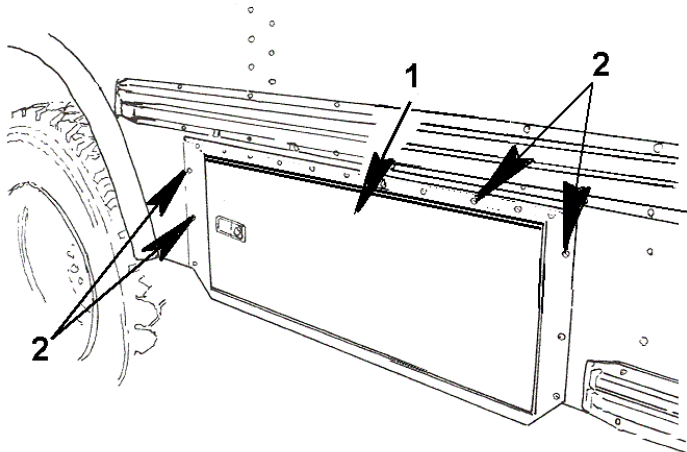

Figure 27 Under Body Storage Compartment

1. UNDERBODY STORAGE COMPARTMENT DOOR ASSEMBLY
2. UNDER BODY FACE SKIN ASSEMBLY MOUNTING HOLES AND SCREWS

Electrical Compartment

The body electrical compartment on the CE bus is located on the driver side directly below the driver side window. This compartment encapsulates all the bus body electrical functions. The body main electrical relays, fuse panels and harness connections are located in this compartment. Located on the inside of the enclosure door is the location schematic for all relays and fuse types and sizes.

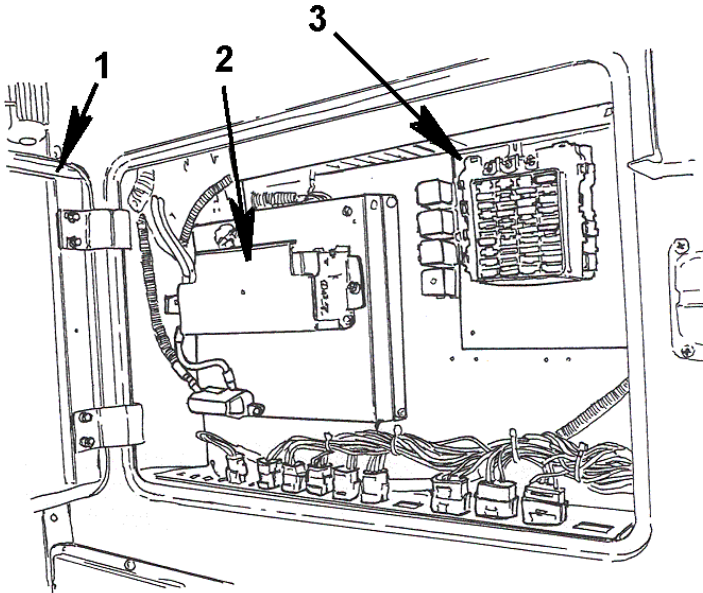

Figure 28 Body Electrical Control Panel

1. HINGED BUS BODY ELECTRICAL PANEL
2. RELAY LOCATIONS COVER PANEL
3. BUS BODY FUSE PANEL

Battery Compartment

The bus battery compartment is located directly below the body electrical control panel compartment on the driver side of the bus body (Fig. 29, Item 3). The compartment is equipped with a slide out type tray (Fig. 30, Item 5) with locking tray latch (Fig. 30, Item 6). The battery compartment is secured by a positive latching device that may incorporate a key locking feature.

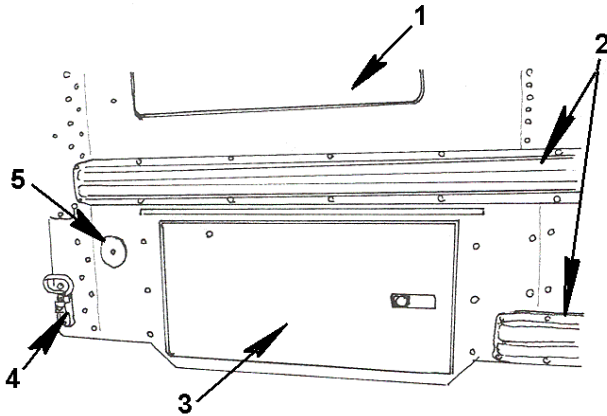

Figure 29 Battery Compartment

1. BODY ELECTRICAL CONTROL PANEL COMPARTMENT
2. BODY SIDE RAILS
3. BATTERY COMPARTMENT ENCLOSURE DOOR WITH LATCH
4. DRIVER ASSIST STEP
5. FORWARD AMBER D.O.T. REFLECTOR

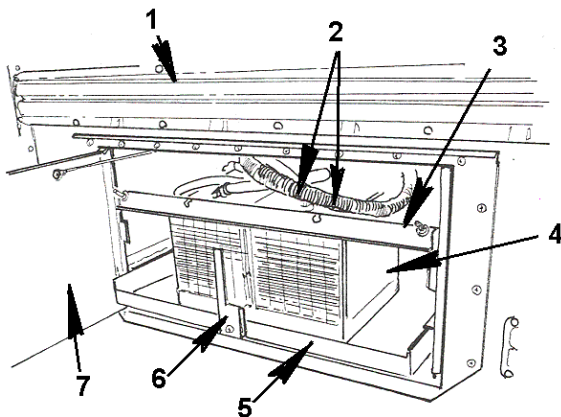

Figure 30 Battery Compartment Sliding Tray

1. BODY RUB RAIL
2. BATTERY CABLES
3. BATTERY TIE DOWN ANGLE
4. BATTERY LOCATION
5. BATTERY SLIDE OUT TRAY
6. SLIDE OUT TRAY LOCKING LATCH
7. BATTERY COMPARTMENT HINGED DOOR

Radio Antenna

The bus may be equipped with an optional AM/FM entertainment radio. The radio would be located in the driver's right hand wing panel. The entertainment radio antenna (Fig. 31, Item 1) is located on the driver side vertical pillar directly to the rear of the driver side window.

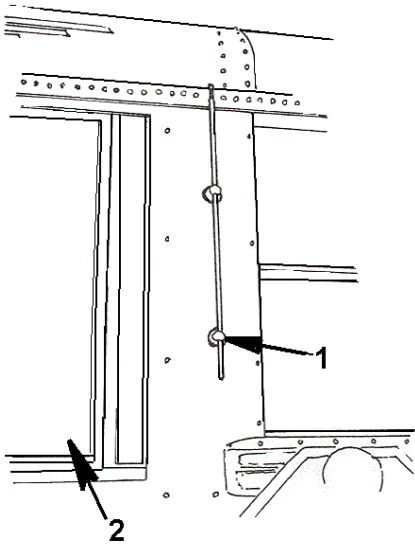

Figure 31 Radio Antenna

1. ENTERTAINMENT RADIO ANTENNA (IF ENTERTAINMENT RADIO EQUIPPED)
2. DRIVER SIDE WINDOW

Chair Lift Door and Chair Lift

Optional handicapped access requirements are an available option. The wheelchair lift is available in different configurations. Depending on the district requirement the chair lift may be located at the rear side bus, at mid point, or directly behind the passenger entry door (Fig. 32, item 1). Depending on the location, the door may swing left or right.

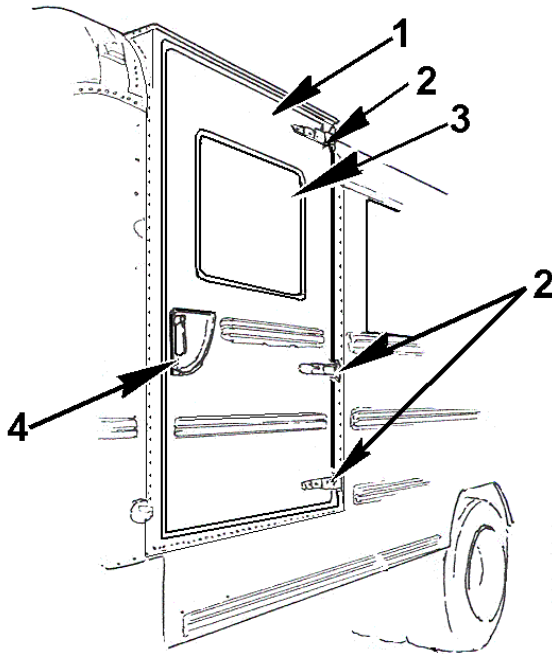

Figure 32 Chair Lift Door (Shown At Rear With Forward Exterior Hinge Assembly)

1. WHEEL CHAIR LIFT ENTRY DOOR
2. EXTERNAL DOOR HINGE ASSEMBLIES
3. WHEEL CHAIR LIFT DOOR WINDOW
4. WHEEL CHAIR LIFT DOOR LATCH

The chair lift option is available from different manufacturers as may be requested by the customer. The chair lift assembly is mounted directly inside the body by the chair lift door. The entire mechanism, depending on manufacturer, is either all electric control or hydraulically controlled. The chair lift door latching mechanism is equipped with a door open sensor which activates when the handle is opened, and alerts the driver the door is ajar. The chair lift operating functions are detailed in the chair lift operators manual if the bus is so equipped.

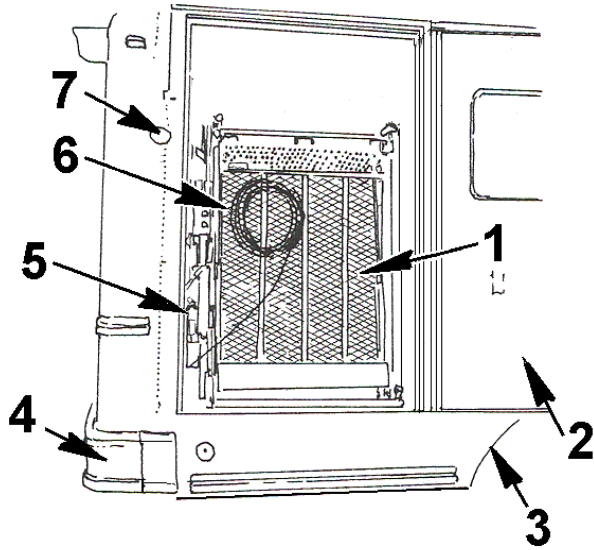

Figure 33 Chair Lift Assembly and Door Opening

1. CHAIR LIFT DECK
2. CHAIR LIFT EXTERIOR ACCESS DOOR
3. REAR WHEEL WELL OPENING
4. REAR BUMPER ASSEMBLY
5. CHAIR LIFT PUMP POWER MODULE
6. REMOTE CONTROLLER CABLE
7. CHAIR LIFT EXTERNAL ACCESS LIGHT

Roof Mounted Strobe Light (Optional)

The roof warning light is located on the center section of the roof structure or as may required by the state or local governing authority. The light is available (Fig. 34) in different types and styles. These lights are generally in use during times when students are in transit on the bus.

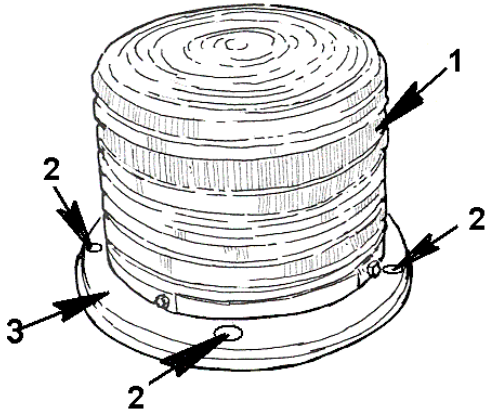

Figure 34 Optional Roof Strobe Warning Light

1. CLEAR OPTICS LENS
2. STROBE LIGHT MOUNTING HOLES
3. LIGHT MOUNTING BASE

Transition Panels

The bus body transition panels are located at the front corners of the bus body directly below the windshield side panels. The driver side transition panel (Fig. 35, Item 2) is furnished with fresh air openings (Fig. 35, Item 3) to the driver heater assembly.

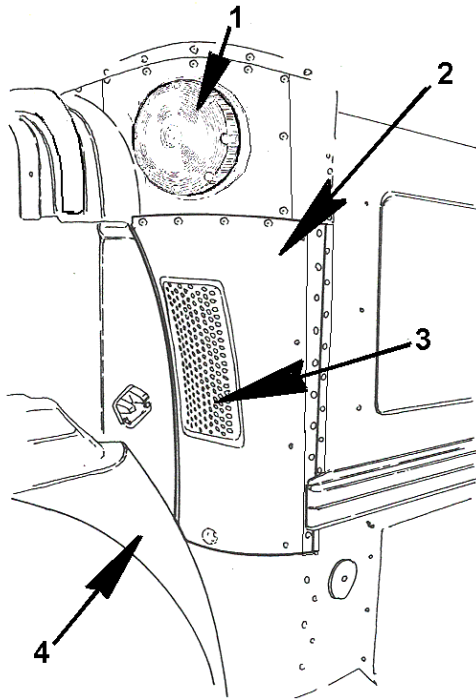

Figure 35 Transition Panel- Driver Side Shown

1. OPTIONAL COWL MOUNTED AMBER DIRECTIONAL LIGHT
2. DRIVER SIDE TRANSITION PANEL
3. FRESH AIR INLET TO HEATER ASSEMBLY
4. DRIVERS SIDE FENDER EXTENSION

End Caps

The end caps are located at the top of the bus body both forward and aft. The front end cap is located directly above the windshield assembly. The front end cap assembly houses the school bus identification or destination sign, the upper front amber warning lights, the red "stop" warning lights, and the required F.M.V.S.S. clearance lights and forward side marker lights. The bulbs that illuminate this option can be accessed from inside the bus. The rear bus end cap is located at the rear of the bus over the rear windows and emergency exit door. The rear end cap is similar in design and function, except that the clearance lights and upper body side marker lights are red instead of amber in color. The location of the warning lights or type of warning light may vary based on the state or local jurisdiction requirements.

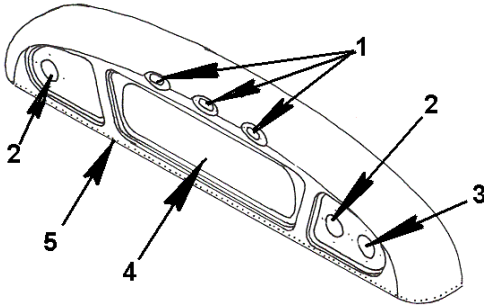

Figure 36 Roof End Caps

1. BODY CLEARANCE LIGHTS
2. RED "STOP" WARNING LIGHTS
3. AMBER WARNING LIGHTS
4. IDENTIFICATION / DESTINATION PANEL
5. END CAP RIVET MOUNTING HOLES

Windshield- 3 Piece

The CE bus incorporates a three piece windshield design. The single piece center panel (Fig. 37, Item 1) allows for full frontal view with no center bar support interference. The side panels (Fig. 37, Item 2) allow for better peripheral vision and rear view mirror visibility. The windshield is encapsulated in a single piece rubber type windshield mounting seal. The center windshield section may be removed and replaced without removing the side panels.

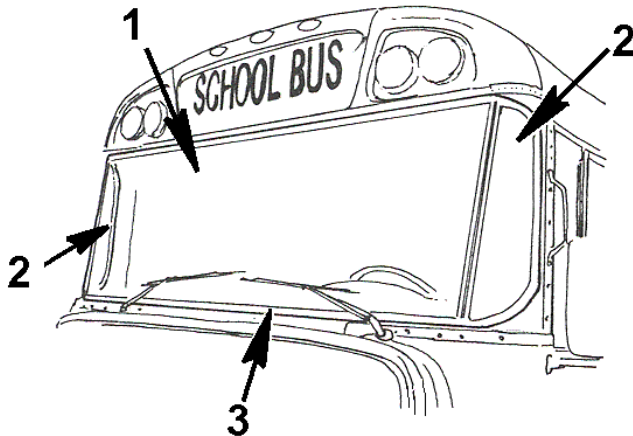

Figure 37 3 Piece Windshield Assembly

1. CENTER WINDSHIELD PANEL
2. WINDSHIELD SIDE PANELS
3. ONE PIECE WINDSHIELD SEAL

Driver Side Window

The school bus driver window is an aluminum two piece sliding window. The window panels, both front and rear, are designed to slide forward and aft. The window is equipped with a positive latching device to secure the window in a closed locked position.

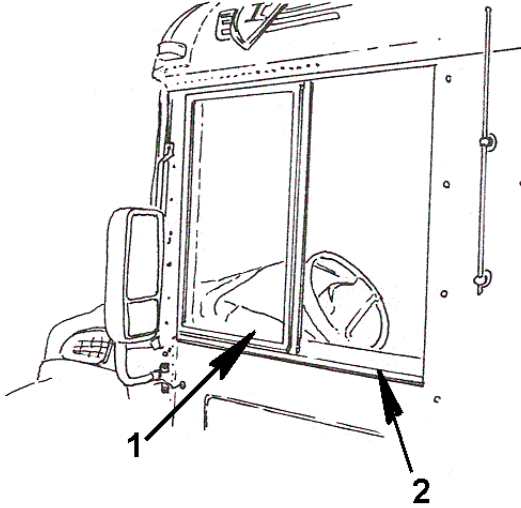

Figure 38 Driver Side Sliding Window

1. DRIVER SIDE SLIDING WINDOW ASSEMBLY
2. DRIVER SIDE SLIDING WINDOW EXTRUDED FRAME

Driver Side Storm Glass Windows

The driver side sliding window is also supplied with a sliding storm window option. The window is designed for use in colder climates and eliminates frost build up on the window in adverse weather. The window glass is a heavier and thicker design.

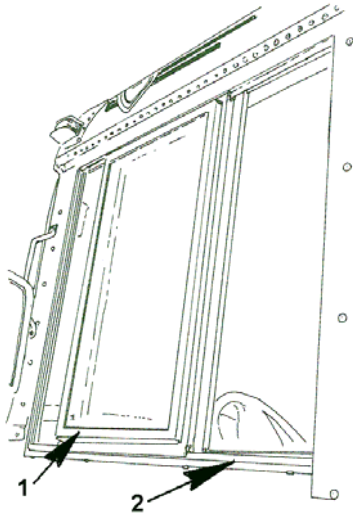

Figure 39 Driver Side Storm Glass Window

1. DRIVER SIDE WINDOW FRAME EXTRUSION
2. DRIVER SIDE STORM WINDOW TRACK EXTRUSION

Static Roof Vents

Static roof vents are provided as a standard on all CE school bus models. The static vents are located at the low pressure point on the roof. Optional roof hatches may be equipped with static vents.

Mud Guards

Mud Guards front and rear are optional equipment.

Rear Wheel Rubber Fenderettes

Rear wheel opening rubber fenderettes are an available option on the CE bus. The fenderettes reduce wheel splash and help minimize body damage.

Body Tie Down Bolts and Assemblies

The body tie down bolts are mechanical fasteners that secure the body floor panels to the chassis frame rail. This application consists of a combination of body tie down clips and 1/2" - 13 x 11 1/2" bolts and nuts equipped with j-bars that fit around the chassis frame rail. A high durometer anti-squeak rubber is located between the bus body floor and the chassis frame rail. The anti-squeak function is to absorb and dampen sound and vibration. Anti-squeak should be in place before the tie down bolts are torqued.

The body tie down bolts should be tightened within 30 days or 1,000– 2,000 miles and quarterly thereafter. The tie down bolts should be torqued 35 to 40 lbf-ft. The body tie down bolts, front outrigger mounting bolts, shear bolts and standard tie downs should be part of a normal preventative maintenance check.

2.5. BUS BODY — INTERIOR

Step Well

The passenger entry step well is located at the front curb side corner of the bus body. The step well entrance has non skid type stair tread with assist handrails for entry and exit assistance.

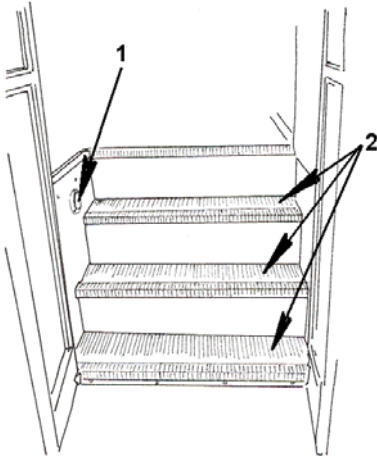

Figure 40 Entrance Step Well

1. STEP WELL LIGHT
2. STEP TREADS

Assist Rails

Assist rails are located at the entry step along the left front bulkhead wall (Fig. 41, item 3). The rails are installed to assist ingress and egress of the passengers. An optional assist handrail is located on the forward bulkhead (Fig. 42, Item 3) below the windshield and dash board extension panel.

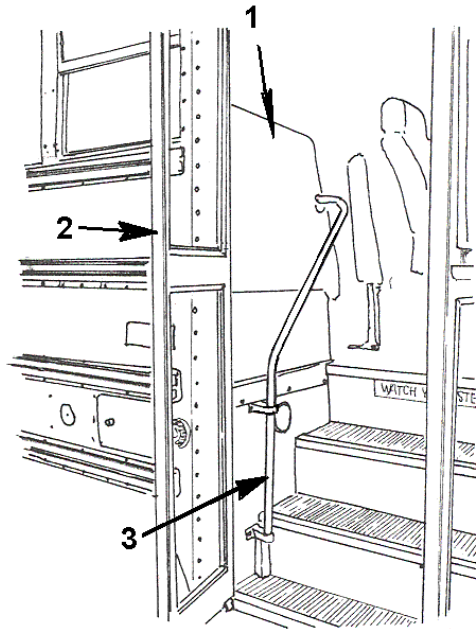

Figure 41 Step Well Assist Rails

1. FRONT CRASH BARRIER
2. ENTRY DOOR
3. STEP WELL ASSIST HAND RAIL

Step Well Heater

The bus entrance may also be supplied with an optional step well heater (Fig. 42, Item 2). The step well heater controls are located on the left wing switch panel.

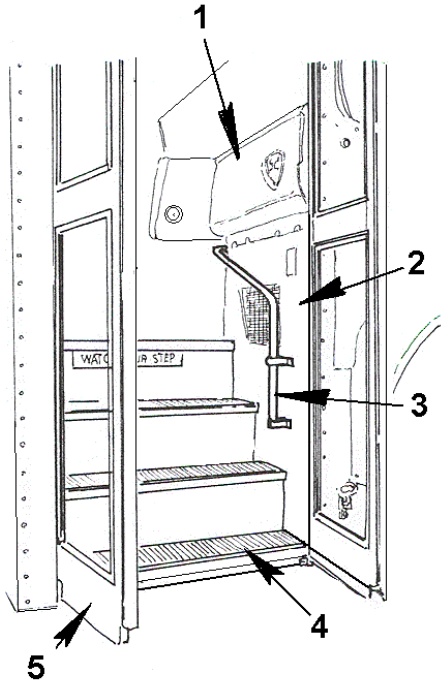

Figure 42 Step Well Heater

1. ENTRY DOOR DASH PANEL EXTENSION
2. STEP WELL HEATER
3. FORWARD OPTIONAL ASSIST HANDRAIL
4. STEP WELL TREADS
5. SWING OUT ENTRY DOORS

Crash Barriers

The crash barriers are located on each side of the bus. The crash barriers are installed to the floor and along the seat rail or to the floor. When flip up emergency exit seats are supplied with the emergency door along the side of the body, an optional crash barrier may be installed for crash protection.

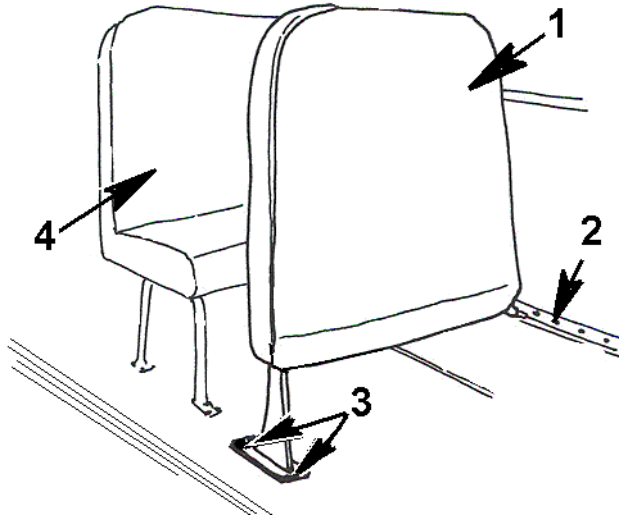

Figure 43 Seat Front Bulkheads

1. SEAT BULKHEAD PANEL
2. CHAIR RAIL MOUNTING
3. FLOOR MOUNTING POSITION
4. FIRST ROW OF SEATS (BEHIND DRIVER SHOWN)

Fire Extinguisher

Fire Extinguishers are supplied and mounted on all school buses. The location may vary depending on the seating arrangement, step well and driver control configurations and state requirements (Fig. 44, Item 1).

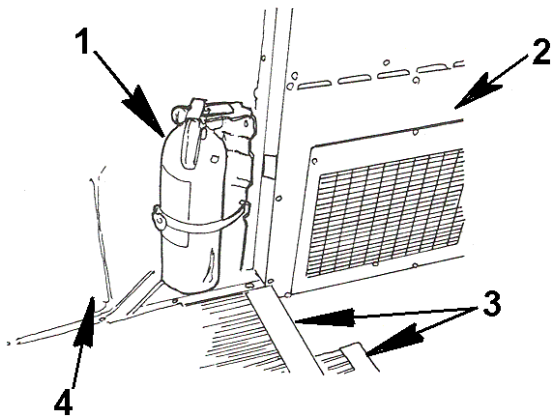

Figure 44 Fire Extinguisher Mounting

1. FIRE EXTINGUISHER (MOUNTED BY STEP WELL HEATER SHOWN)
2. STEP WELL HEATER GRILLE
3. ENTRANCE STEP TREADS
4. INTERIOR ENGINE COVER

Driver Controls / Instrument Panel

The driver's control panel is an ergonomically designed full function driver control system. All instruments and controls are situated to allow driver full function control with limited hands off the steering wheel at any given time. Door operation, warning light control functions and other optional items are placed in the steering wheel to allow more control for the driver.

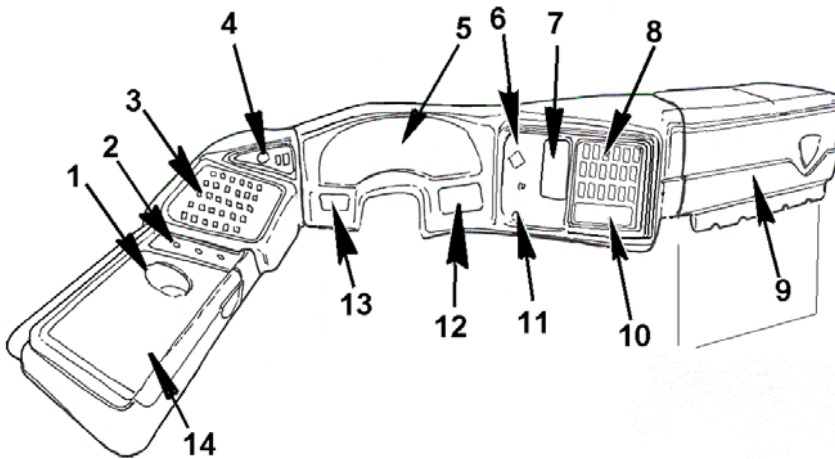

Figure 45 Dash Board and Components

1. DRIVER'S LEFT WING STORAGE COMPARTMENT WITH CUP HOLDER
2. HEATER AND BLOWER CONTROLS
3. SWITCH PANEL FOR VARIOUS BODY FUNCTIONS
4. OPTIONAL AIR RESTRICTION INDICATOR LOCATION AND FUNCTIONAL SWITCHES
5. INSTRUMENT CLUSTER
6. PARKING BRAKE SWITCH
7. TRANSMISSION SELECTOR CONTROL
8. OPTIONAL SWITCH PANELS
9. RIGHT ENTRANCE WING PANEL
10. ENTERTAINMENT RADIO (OPTIONAL)
11. IGNITION KEY
12. ECON SWITCH
13. PANEL LIGHTS AND HEADLIGHT SWITCHES
14. LIFT UP STORAGE COMPARTMENT COVER

Refer to Fig. 46 for all items in parentheses.

Driver wing panel is located to the right of the driver position and contains various functional items: including the transmission shifter (Item 3), parking brake control, the ignition key (Item 8), various function switches (Item 5), and other items. (See callouts for other available options.)

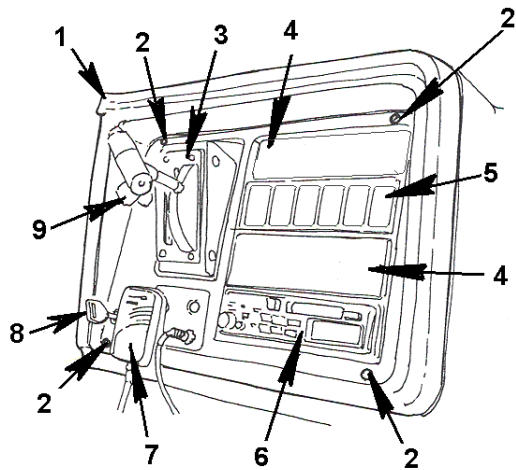

Figure 46 Driver Side Wing Panel

1. WING PANEL TRIM RING
2. PANEL MOUNTING SCREWS
3. TRANSMISSION SHIFTER
4. BLANK
5. SWITCH BANK
6. ENTERTAINMENT RADIO (OPTIONAL)
7. MICROPHONE FOR PA SYSTEM OR COMMUNICATION RADIO
8. IGNITION KEY AND SWITCH
9. BRAKE SWITCH

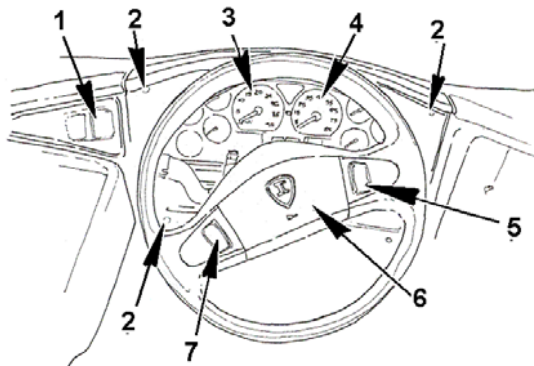

Figure 47 Steering Wheel and Dash Cluster

1. AIR RESTRICTION INDICATOR GAUGE (OPTIONAL)
2. DASH CLUSTER COVER PLATE AND BEZEL MOUNTING SCREWS
3. TACHOMETER
4. SPEEDOMETER
5. CRUISE CONTROL OR PUPIL WARNING LIGHT CONTROL
6. HORN BUTTON
7. CRUISE ON/OFF OR DOOR CONTROL

The steering wheel switch functions may vary based on the requirements chosen by the school district. See operators manual for actual switch function and/or location.

Steering wheel switch functions may include passenger door opening function, (Fig 47, Item 7) both electric and optional air control or cruise control on / off. The pupil warning lights may also be included in the steering wheel switch module (Fig. 47, Item 5) or cruise control functions. Both the electric and air operated door openers have an emergency override switch located over the door entrance. An optional, manual door opener is available in place of the standard electric door control (Fig. 89).

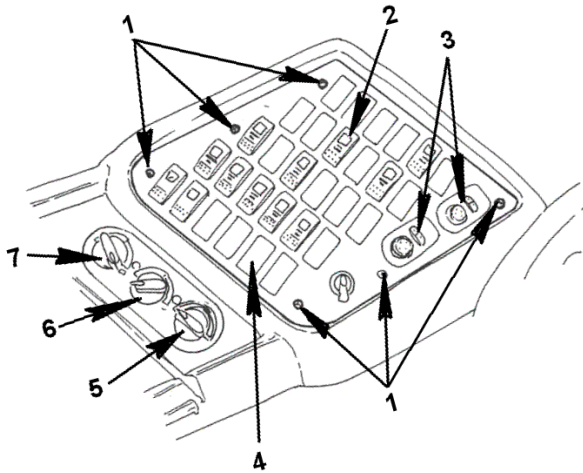

Figure 48 Driver Side Switch Panel

1. SWITCH PANEL FACE MOUNTING SCREWS
2. SWITCH ASSEMBLY
3. ELECTRIC MIRROR CONTROLS (OPTIONAL)
4. SWITCH BLANKS
5. TEMPERATURE CONTROL
6. HEAT CONTROL (DRIVER / PASSENGER)
7. AIR CONTROL (RECIRCULATE / FRESH)

The driver side left wing switch panel is located at the left console. This switch panel contains the controls for environmental controls, body interior light functions, electric rear view mirrors and other options.

The driver side wing storage compartment is located to the rear of the left wing switch panel. The compartment has a removable hinged top. An inside storage compartment 12 volt power supply plug with protective cap is an available option.

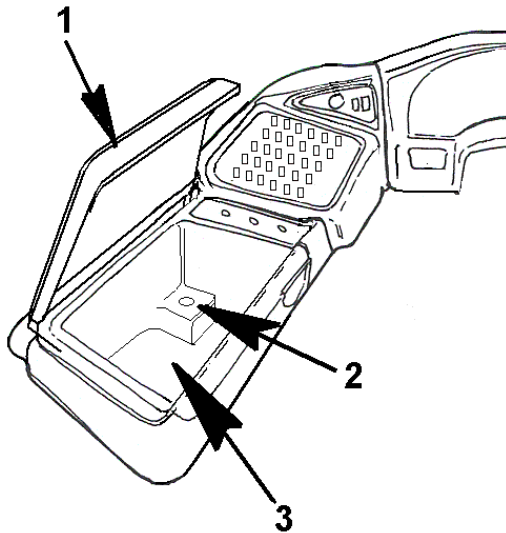

Figure 49 Driver Side Storage Compartment

1. STORAGE COMPARTMENT HINGED COVER
2. 12 VOLT POWER SUPPLY PLUG IN
3. STORAGE COMPARTMENT BOTTOM

Driver Side Sliding Window

The driver side sliding window is an aluminum extruded sliding window assembly with a positive latching device to secure the window in a closed position. The forward section of the window slides full length aft when the rear window is in closed position. The rear window slides full length forward, when front section is closed.

Driver Side Storm Window Assembly (Optional)

When specified, the optional driver side sliding storm window assembly is available. This sliding window assembly utilizes a thicker thermal type glass mounted in an aluminum extrusion. The window is mounted in the window frame area but has an offset extruded framework to compensate for the glass thickness.

Driver Seat

The driver seat is located in the driver platform and is secured at the base of the front bus floor frame. The driver seat is supplied with a three point seat belt assembly. The standard seat is manually adjusted for back tilt and fore and aft positions. Other optional driver seat assemblies are available, and are addressed in the operators manual supplied with the vehicle.

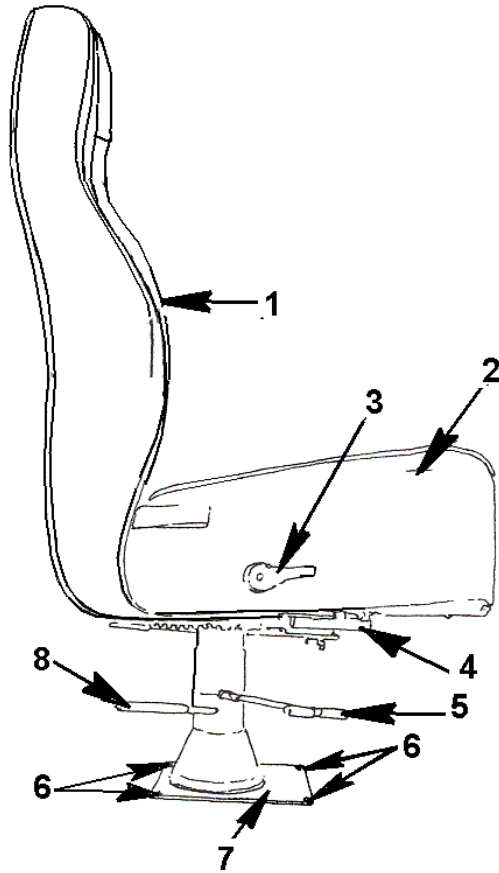

Figure 50 Driver Seat

1. DRIVER SEAT BACK
2. DRIVER SEAT CUSHION
3. VERTICAL SEAT BACK ADJUSTMENT
4. FORE AND AFT SEAT ADJUSTMENT
5. SEAT HEIGHT ADJUSTMENT
6. DRIVER SEAT MOUNTING BOLTS
7. DRIVER SEAT MOUNTING BASE
8. SEAT SWIVEL LOCK

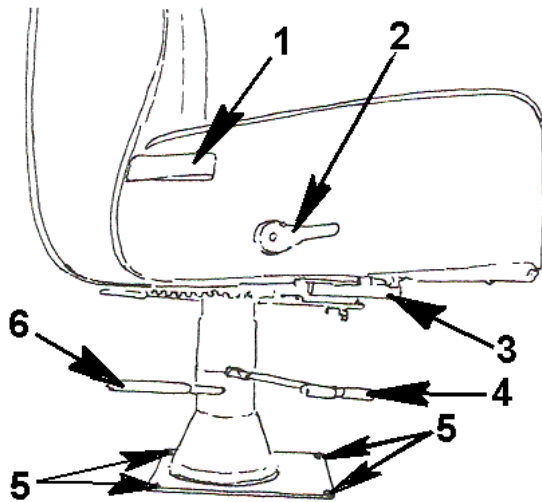

Figure 51 Driver Seat Adjustments

1. SEAT BELT RETAINER STRAP
2. SEAT BACK TILT ADJUSTMENT
3. FORE AND AFT SEAT ADJUSTMENT
4. SEAT HEIGHT ADJUSTMENT
5. SEAT BASE MOUNTING BOLTS
6. SEAT SWIVEL LOCK

Heater and Defroster

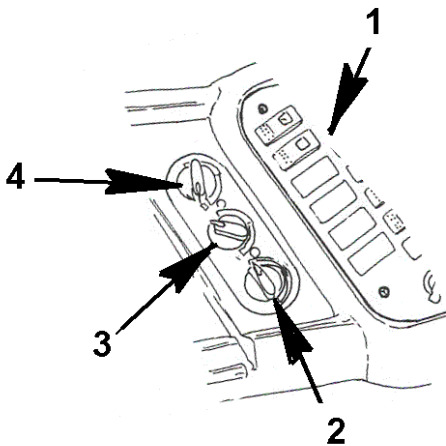

Figure 52 Heater Controls

1. DRIVER SIDE LEFT WING SWITCH PANEL
2. TEMPERATURE CONTROL
3. HEAT CONTROL (DRIVER / PASSENGER)
4. AIR CIRCULATION CONTROL (RECIRCULATE / FRESH)

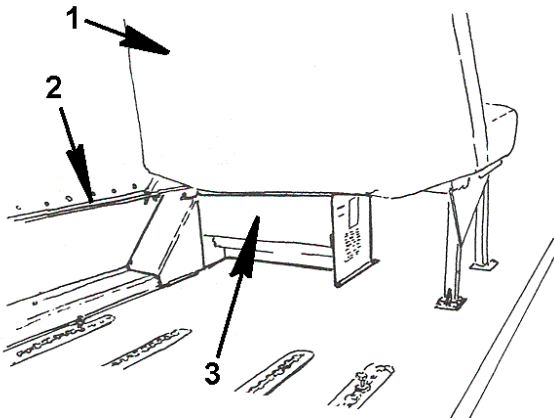

Figure 53 Under Seat Heater (30" Seat Shown)

1. SEAT BACK ASSEMBLY
2. CHAIR MOUNTING RAIL
3. UNDER SEAT HEATER ASSEMBLY

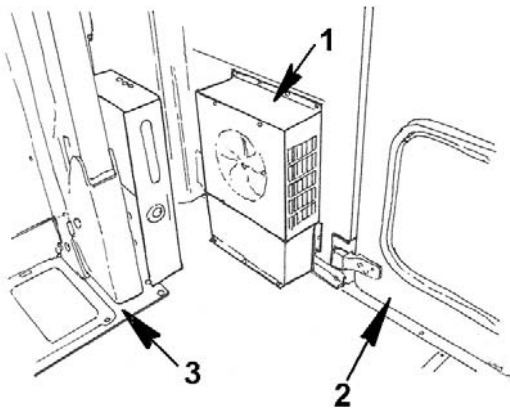

Figure 54 Auxiliary Rear Heater

1. OPTIONAL REAR BULKHEAD HEATER AND BLOWER ASSEMBLY
2. REAR EMERGENCY EXIT DOOR
3. OPTIONAL HANDICAPPED WHEELCHAIR LIFT ASSEMBLY

Light Bars

The bus light bars run from the front of the bus body interior to the rear bulkhead above the passenger side window assemblies. The light bar encapsulated wiring harness connections to the rear end cap, emergency door and window alarm switches and for speaker assemblies may be specified. The end cap covers at each end of the light bar cover the junction points for the various harness connection plugs.

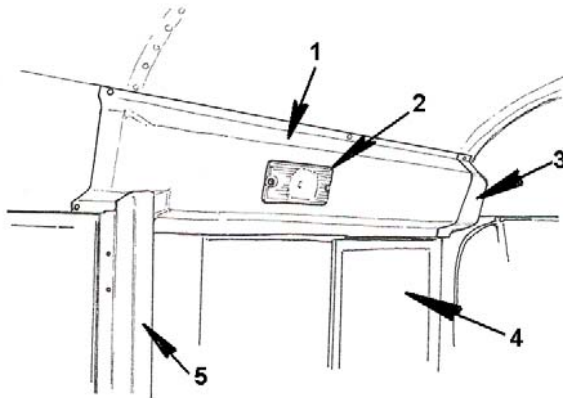

Figure 55 Driver Side Light Bar

1. LIGHT BAR ASSEMBLY
2. DRIVER SIDE OVERHEAD LIGHT
3. LIGHT BAR END CAP (JUNCTION COVER)
4. DRIVER SIDE SLIDING WINDOW
5. HARNESS FEED COVER TO LIGHT BAR

The driver side light bar assembly is located directly over the driver side sliding window. The light bar section contains an overhead light for the driver (Fig. 55, Item 2) and may include an audio speaker. Directly behind the driver seat is the light bar harness cover and tee (Fig. 55, Item 5). The tee connection furnishes the harness leads to the various parts of the bus body through the light bar assemblies.

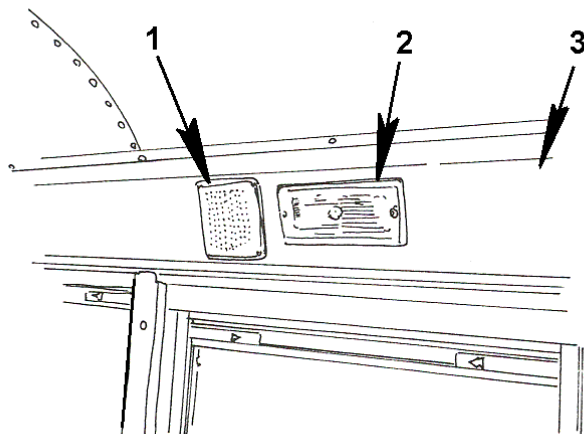

Figure 56 Light Bar with Speaker and Light

1. LIGHT BAR MOUNTED SPEAKER (OPTIONAL)
2. LIGHT BAR MOUNTED LIGHT ASSEMBLY
3. LIGHT BAR ASSEMBLY

Light bar assemblies along the upper portion of the body interior (Fig. 56, Item 3) house passenger compartment lighting (Item 2) and optional speaker assemblies (Item 1).

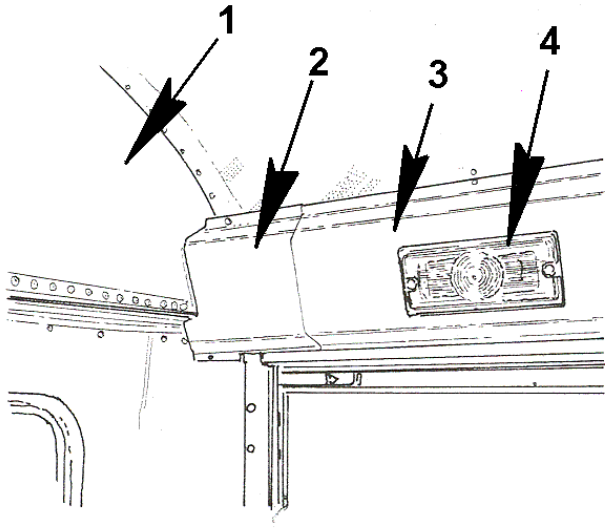

Figure 57 Rear Junction Cover and Light

1. INTERIOR BULKHEAD AT END CAP
2. LIGHT BAR END CAP AND HARNESS JUNCTION COVER
3. LIGHT BAR ASSEMBLY
4. PASSENGER AREA LIGHT BAR MOUNTED LIGHT

The rear light bar assembly tee cover (Fig. 57, Item 2) at the rear interior end cap is removable and allows access to the various harness connections for the rear of the bus body. The harness plug connections for the rear electrical components on the bus body are serviceable from this point.

Flooring

The school bus flooring may vary in color and material type per the requirements of the school district. The center isle is a raised surface type tread to eliminate possible slipping in the walkway area. The entrance area and step well are also a tread style flooring. The wheel well covers are a black composite molded material (Fig. 58, Item 2) with the heater hoses enclosed in the outer section (Fig. 58 Item 3) of the wheel well cover against the bus wall.

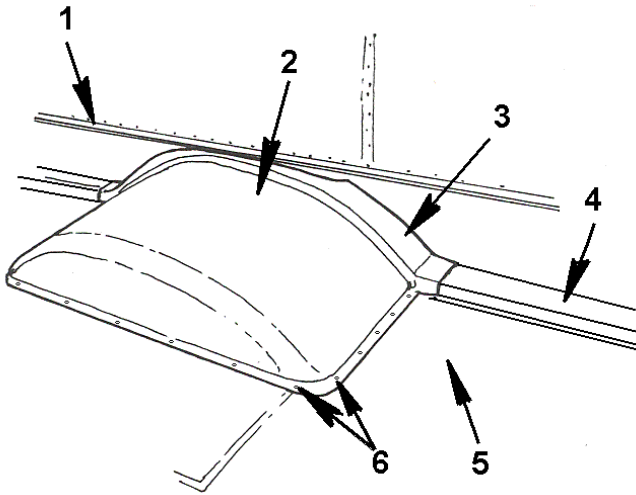

Figure 58 Wheel Well Cover

1. CHAIR MOUNTING RAIL
2. WHEEL WELL COVER
3. MOLDED HEATER HOSE COVER INTEGRAL WITH WHEEL WELL COVER
4. HEATER HOSE COVER ALONG BUS WALL
5. BUS FLOOR COVERING
6. WHEEL WELL COVER MOUNTING SCREWS

Seats and Seating

The standard school bus seating varies with the bus length or seat plan arrangement per the school district requirements. The row of seats can vary in seat length. Seats and mounting types may vary depending on the seat configuration required by the school district. Two leg with chair rail (Fig. 59, Item 3) mounting is standard. Options include 4 leg seat mounting, track seating hardware and wheel chair mounts.

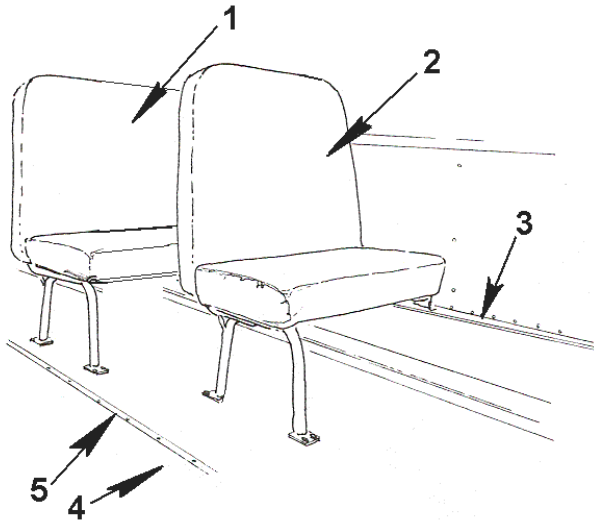

Figure 59 30" and 45" Passenger Seats and Chair Rail Mounting

1. TYPICAL 45 INCH SEAT
2. TYPICAL 30 INCH SEAT
3. TYPICAL CHAIR MOUNTING RAIL
4. ISLE WAY FLOORING RUNNER
5. FLOOR AND ISLE TRIM STRIP

Small Child Restraint Seat

The Small Child Restraint Seat (Fig. 60) is an optional seat provided for children under certain height and weight designations. The seats are provided with a drop down cushion panel and shoulder harnesses to secure the specific child.

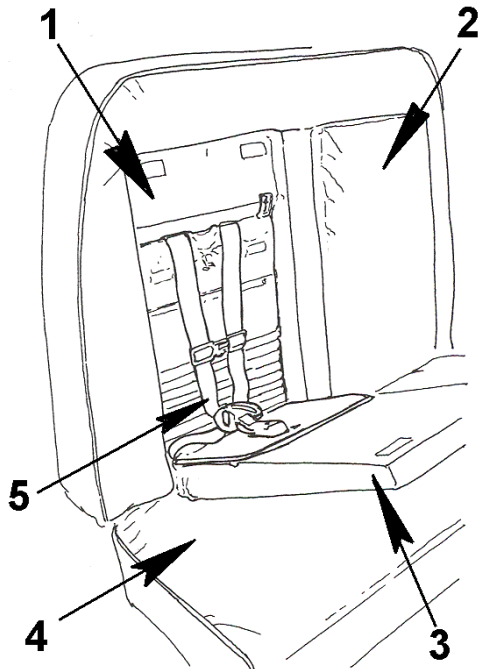

Figure 60 Child Safety Seat (Optional)

1. SMALL CHILD RESTRAINT SEAT INNER PANEL
2. SMALL CHILD RESTRAINT SEAT IN UPRIGHT POSITION
3. SMALL CHILD RESTRAINT SEAT IN OPEN POSITION
4. STANDARD SEAT CUSHION BOTTOM
5. CHILD SAFETY SEAT HARNESS SEAT BELTS

Two Point Lap Belts

Two point seat belts (Fig. 61, Item 1) are an available option. The seats may be a 2 leg with chair rail mount, 4 leg direct mount or four leg with floor track (Fig. 61, Item 2) for adjustability.

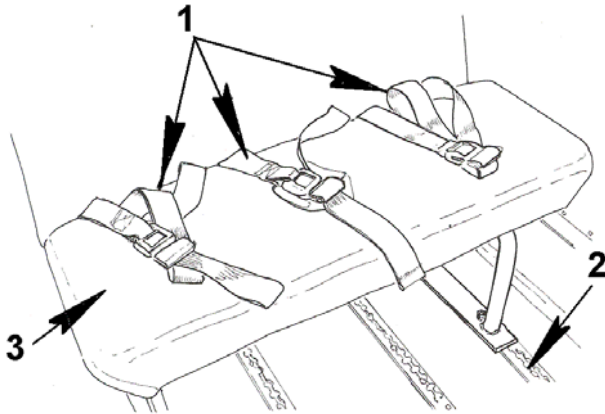

Figure 61 Two Point Lap Belts

1. TWO POINT LAP BELT ASSEMBLIES (45" SEAT SHOWN)
2. OPTIONAL FLOOR MOUNTED TRACK
3. STANDARD SEAT BOTTOM FRAME AND CUSHION

Flip Up Emergency Exit Seats

Flip up bottom emergency exit seats are also an available option (Fig. 62, Item 1 and 2). These seats are mounted at the emergency exit door location, and have spring operation to keep them in the open position, until weight is placed on the seat to hold the seat cushion down in the transport position.

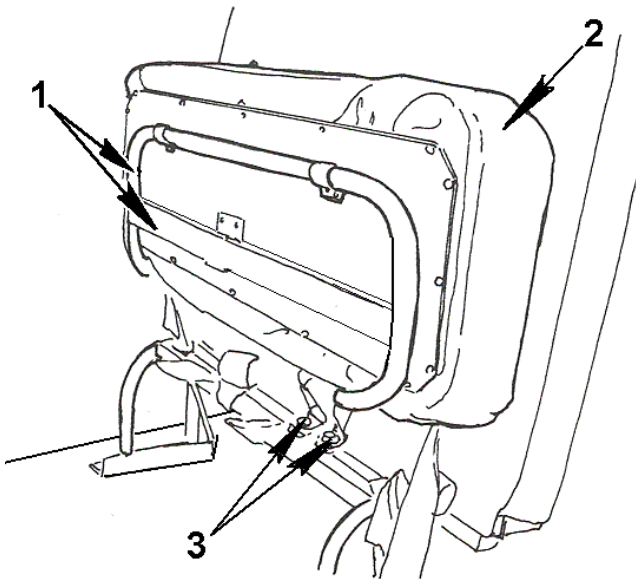

Figure 62 Emergency Exit Flip Up Seats

1. FLIP UP EMERGENCY EXIT SEAT TUBE AND BOTTOM STRUCTURE
2. FLIP UP EMERGENCY SEAT CUSHION
3. 2 POINT SEAT BELT (OPTIONAL) MOUNTING BOLTS AND NUTS

Windows

The standard passenger windows are an aluminum extruded window assembly. The windows are equipped with a positive latch drop down type upper window section. Slide latch mechanisms are located at the upper corners of each window assembly to lock the window in the desired position. The window assemblies are completely removable for serviceability, from the bus interior.

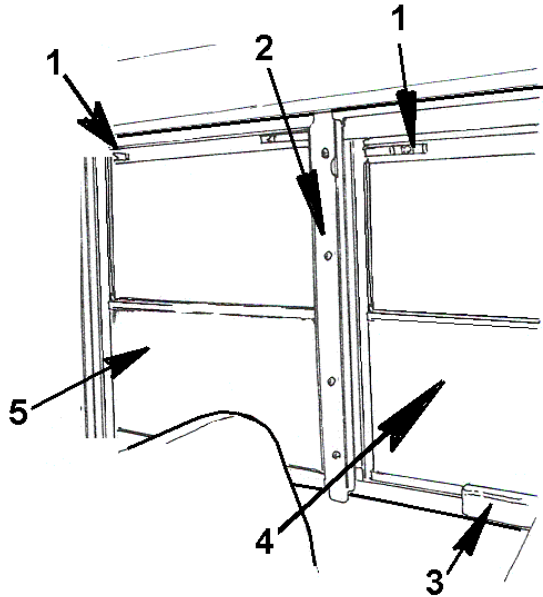

Figure 63 Standard Passenger Windows

1. TOP WINDOW LOCKING LATCH
2. WINDOW POST COVER PLATE
3. EMERGENCY WINDOW LOCKING LATCH
4. EMERGENCY WINDOW LOCK LATCH
5. EMERGENCY WINDOW LOWER GLASS PANEL

Passenger windows are sealed thermal glass panels that are easily serviced if damaged.

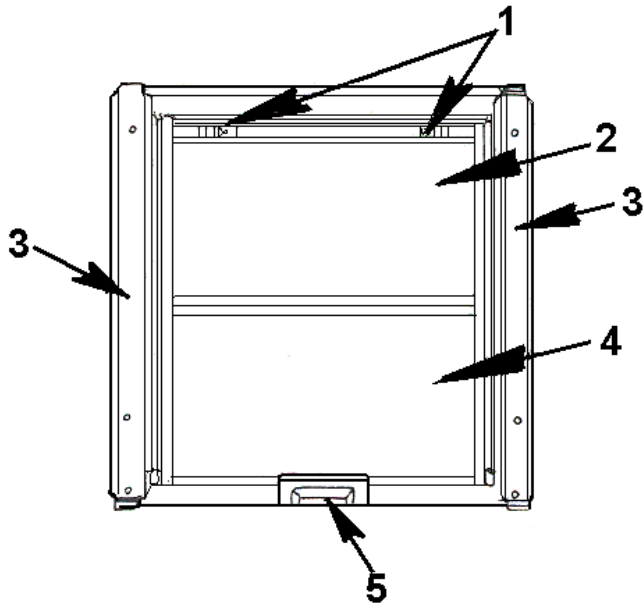

Figure 64 Emergency Exit Push Out Windows

1. WINDOW LATCHES
2. UPPER WINDOW PANE (WINDOW AND FRAME SLIDES UP AND DOWN)
3. WINDOW TRIM COVER PLATES
4. STATIONARY WINDOW PANE (LOWER)
5. EMERGENCY WINDOW RELEASE LATCH

The bus body is equipped with emergency exit windows and doors. Opening an emergency window or door will activate an alarm or buzzer (Fig. 65, Item 4) at the driver's position when the key is in the on or accessory position. Depending on the local requirements the emergency window will unlatch and push out and is either vertically or horizontally hinged.

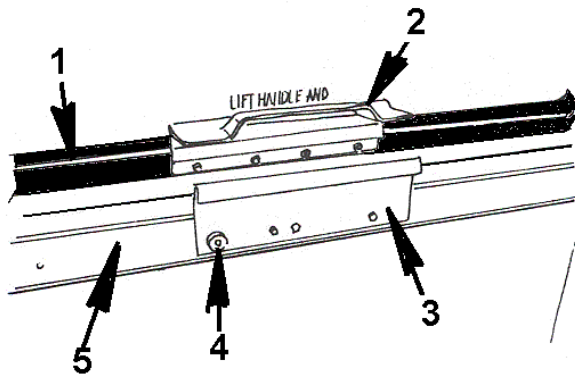

Figure 65 Emergency Window Open — Relay Switch

1. WINDOW SEAL
2. EMERGENCY WINDOW EXIT LATCH
3. EMERGENCY WINDOW EXIT CLIP
4. EMERGENCY WINDOW AJAR WARNING SWITCH
5. LOWER WINDOW SILL

Emergency Exit Door Lower Glass Protection Screen

An optional lower rear emergency door window glass protection shield is available to protect the lower door glass panel from damage.

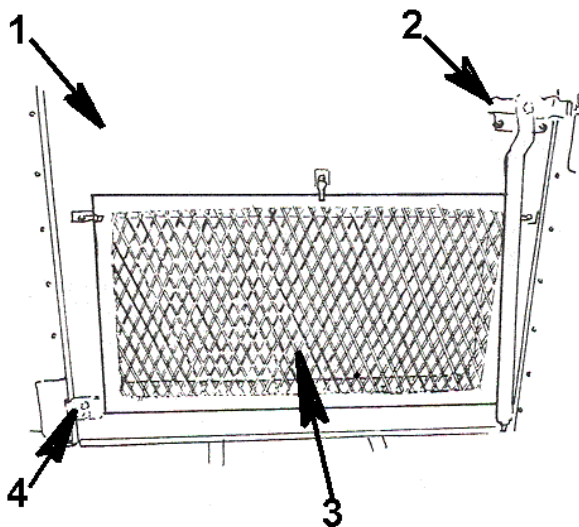

Figure 66 Lower Door Glass Protection Screen

1. REAR EMERGENCY DOOR
2. EMERGENCY DOOR LATCH AND WARNING RELAY
3. LOWER GLASS WINDOW PROTECTION SCREEN
4. LOWER DOOR HINGE

Emergency Exit Latches and Alarms

The bus is equipped with an emergency door latch and driver warning switch that is activated when the door latch mechanism (Fig. 67, Item 1) is opened. This switch activates (Fig. 67, Item 4) an alarm and flashing light at the driver's control panel.

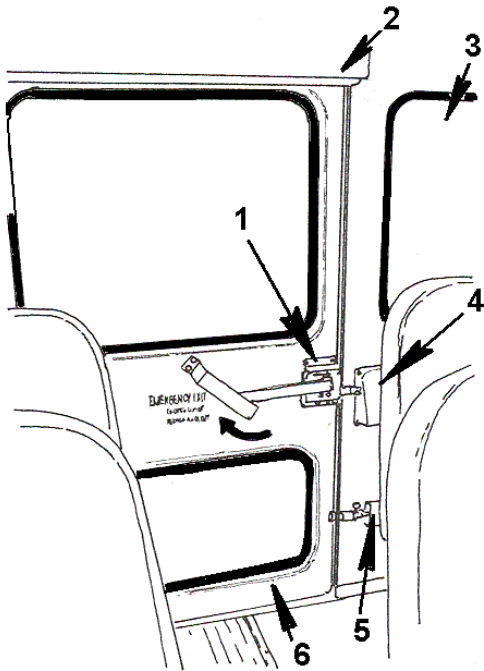

Figure 67 Emergency Exit Door and Related Hardware

1. EMERGENCY DOOR LATCH
2. CUSHIONED HEAD BUMPER
3. REAR WINDOW ASSEMBLY— DRIVER SIDE
4. EMERGENCY DOOR LATCH RELAY ASSEMBLY
5. BOLT LATCH (OPTIONAL WITH STARTER INTERLOCKS)
6. EMERGENCY EXIT DOOR

The emergency roof escape hatch (Fig. 68, Item 2) when specified allows egress from the interior of the bus in situations when the bus may not be in an upright position. The roof escape hatch when specified is available with a lift up vent opening (Fig. 21, Item 1).

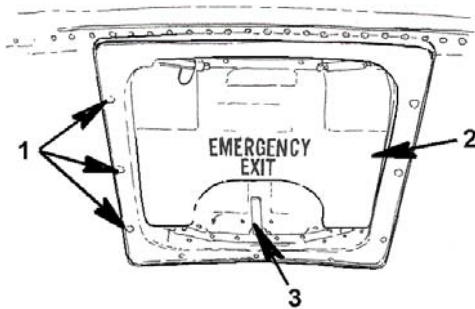

Figure 68 Emergency Roof Exit Hatch

1. ROOF MOUNTED FRAME AND MOUNTING BOLTS
2. EMERGENCY ROOF HATCH
3. EMERGENCY EXIT HATCH RELEASE HANDLE

Exterior Light Monitor (Optional)

When specified, the exterior light monitor (Fig. 69, Item 2) is mounted in the overhead console panel. This monitor indicates the status of the amber and red flashing warning lights at the front and rear of the bus body. The monitor is available in 8, 12 and 16 light configurations.

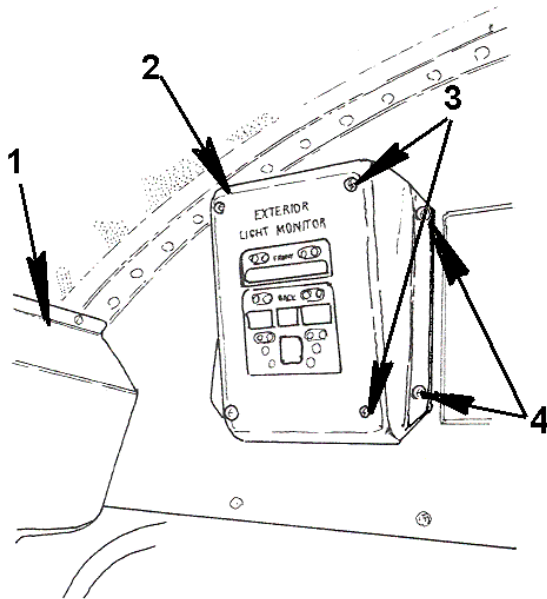

Figure 69 Exterior Light Monitor (Optional Eight Light monitor Shown)

1. DRIVER SIDE LIGHT BAR
2. EXTERIOR LIGHT MONITOR ASSEMBLY
3. EXTERIOR LIGHT PANEL COVER MOUNTING SCREWS
4. EXTERIOR LIGHT MONITOR MOUNTING SCREWS

Safety Equipment- Reflective Road Triangles

Reflective road hazard triangles required by F.M.V.S.S. (Fig. 70, Item 2) are mounted and secured in locations easily accessible to the driver. Actual storage locations may vary.

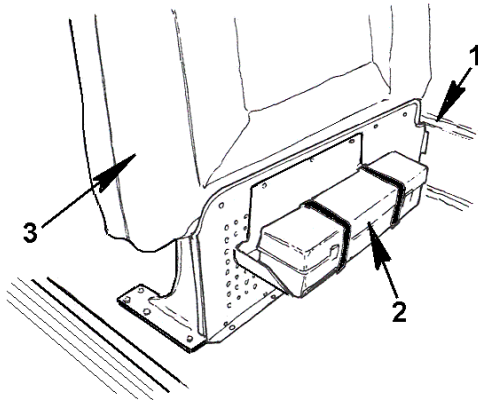

Figure 70 Reflective Triangles and Case

1. DRIVER SIDE SEAT CRASH BARRIER
2. REFLECTIVE TRIANGLES, CASE AND MOUNTING BRACKET
3. SEAT MOUNTING CHAIR RAIL

Seat Tracks

Seat track requirements (Fig. 71, Item 3) are available for various seat configurations and seat type applications. Seat track and wheel chair tie downs are available for different configuration of seating plans when required. The tracks are mounted to the floor and use a stud and locking clip (Fig. 71, Items 1 and 2) to allow the movement of seat rows as required.

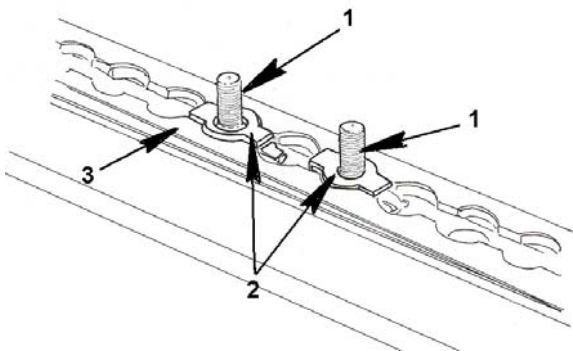

Figure 71 Seat Track and Seat Mounting Studs

1. SEAT MOUNTING STUD
2. SEAT STUD RETAINER CLIP
3. SEAT TRACK

Seat track may be installed to facilitate various width seat rows.

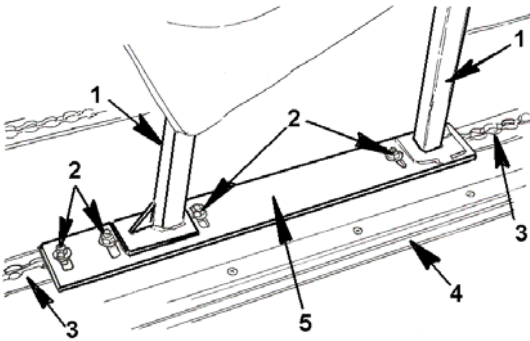

Figure 72 Seat Track and Seat Mounting Base

1. SEAT ASSEMBLY LEGS
2. SEAT MOUNTING STUDS AND NUTS
3. SEAT TRACK
4. RIBBED ISLE FLOORING
5. SEAT MOUNTING BASE

Wheel Chair Shoulder Harness Mounting and Storage

Shoulder harness tracks (Fig. 73, Item 2) are an available option used in conjunction with wheel chair wheel floor track. The seat belt and harness assembly are stored in a secured carrying bag (Fig. 74, Item 2) attached to the shoulder harness track assembly.

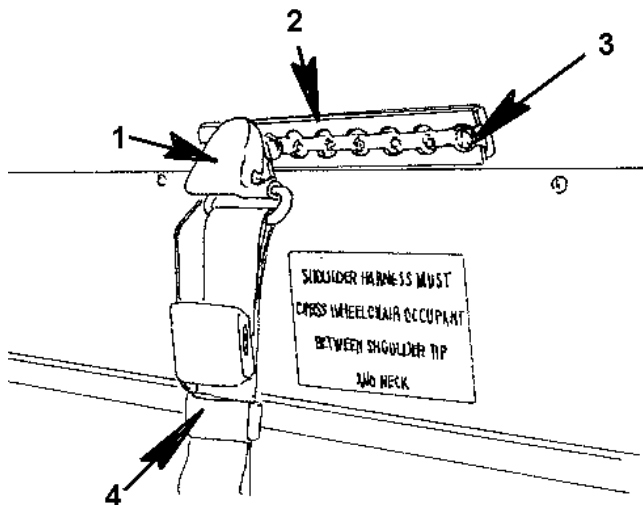

Figure 73 Shoulder Harness Track

1. SHOULDER HARNESS ATTACHMENT ASSEMBLY
2. SHOULDER HARNESS TRACK
3. SHOULDER HARNESS TRACK TORQUE HEAD MOUNTING SCREWS
4. SHOULDER HARNESS BELT

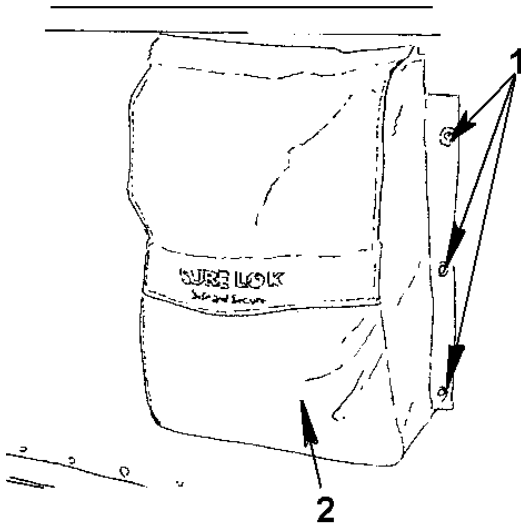

Figure 74 Shoulder Harness Storage Bag

1. HARNESS BAG MOUNTING SCREWS
2. SHOULDER HARNESS STORAGE BAG

Wheelchair Access Door and Chair Lift

When required, the bus is equipped with a wheelchair lift (Fig. 76, Item 3) and access door (Fig. 32, Item 1). The door is a hinged door with a 180 degree opening angle (Fig. 33, Item 3). The door is equipped with an activation alarm relay that activates when the door is opened while the bus is in operation or with the key on accessory. The door is equipped with a cable retainer to hold the door in a full open position (Fig. 79, Item 2).

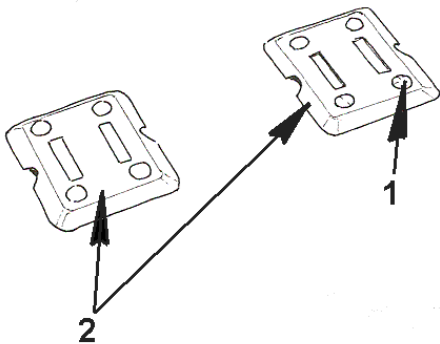

Figure 75 Wheel Chair Floor Plates

1. WHEELCHAIR LOCK PLATES MOUNTING BOLTS
2. WHEELCHAIR LOCKING PLATES



WARNING – This product has been designed and manufactured to exact specification. Modification of this product in any respect can be dangerous.

The chair lift assembly is equipped with ADA features and is mounted at different locations as specified by the school district. Different models and weight capacities are available per customer specifications.

NOTE – Styles and functional controls vary by manufacturer, check the manufacturers owners manual for actual application.

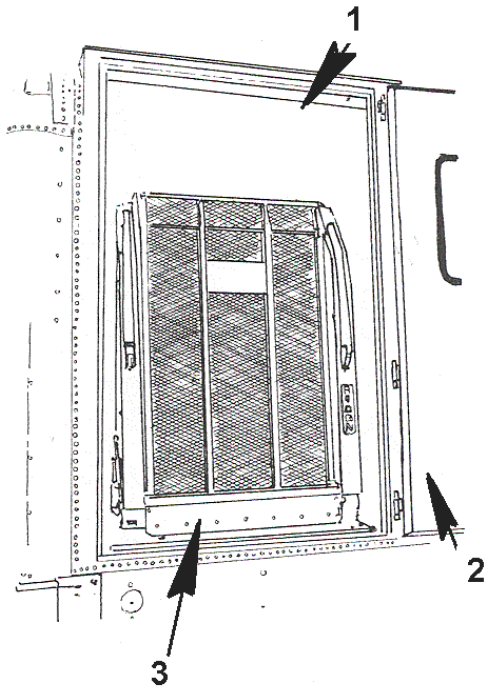

Figure 76 Wheelchair LIFT - Stored Position

1. WHEELCHAIR LIFT DOOR OPENING
2. CHAIR LIFT DOOR IN OPEN POSITION
3. CHAIR LIFT ASSEMBLY IN CLOSED POSITION

Reference Chair Lift Operators Manual for proper use and maintenance of chair lift.

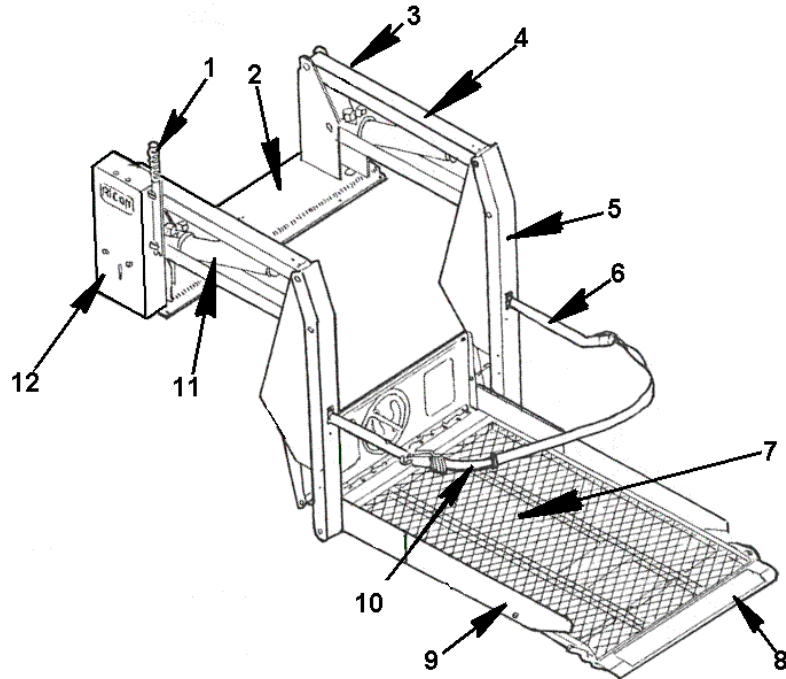

Figure 77 Wheelchair Lift — In Open Position

1. MANUAL BACK-UP PUMP HANDLE
2. BASE PLATE ASSEMBLY
3. SERIAL NUMBER
4. TOP/BOTTOM ARMS
5. VERTICAL ARM
6. HANDRAILS
7. PLATFORM
8. PLATFORM ROLL STOP
9. PLATFORM SIDE RAIL
10. OCCUPANT RESTRAINT BELT
11. HYDRAULIC CYLINDER
12. HYDRAULIC POWER UNIT

Chair Lift Remote Controller

The chair lift assembly is supplied with a remote operators pendant (Fig. 78) that mounts in the chair lift area for operator use. The remote pendant consists of the pendant controller (Item 1), the mounting clip (Item 2), and the power cable connector (Item 3). The pendant assembly connector plugs into the base section of the hydraulic pump assembly (Fig. 79, Item 5).

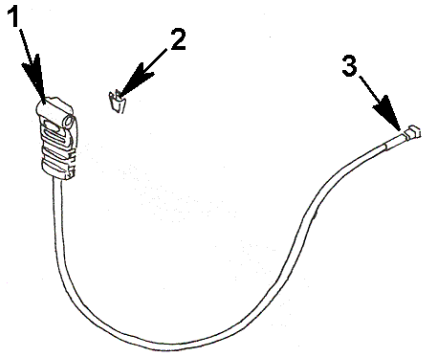

Figure 78 Wheelchair Lift Controller

1. CONTROL PENDANT
2. PENDANT MOUNTING CLIP
3. PENDANT PLUG IN CONNECTOR

The wheelchair lift contains a powerful electro-hydraulic pump that includes a built-in manual back up pump. If the unit loses electrical power, it can be raised or lowered manually. By using the control switch, the lift is unfolded out from the vehicle. The user boards the large non-skid platform and the operator uses the control switch to gently lower the platform to the ground. After the user departs, the platform is raised and folded into the vehicle (stowed). It is important to user safety that the lift operator be completely familiar with the operating instructions. Once the lift is installed, it is also important that the lift be properly maintained by following the manufacturer recommended cleaning, lubrication, and inspection instructions. If the bus is equipped with a wheelchair lift, check the lift instruction, and maintenance manual for the proper procedures to maintain the lift.

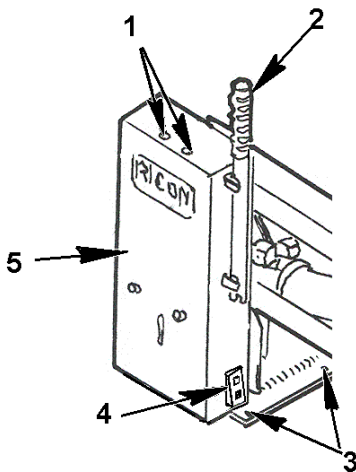

Figure 79 Wheelchair Lift Power Unit

1. POWER ON AND INTERLOCK INDICATOR LIGHT
2. MANUAL BACK UP PUMP HANDLE
3. BASE PLATE MOUNTING BOLTS
4. PENDANT CONTROLLER CONNECTION
5. HYDRAULIC PUMP UNIT COVER ASSEMBLY

Chair Lift Door and Latches

The wheelchair lift door assembly is similar in operation to the Emergency Exit Door. The door is equipped with an open door activation relay that notifies the driver in the event the door latch has been opened. The chair lift door is a full 180 degree swing open door with a door restraint cable and clip located on the outside bus body (Fig. 80, Item 3).

The door latch mechanism is opened from the outside of the vehicle by lifting the handle (Fig. 32, Item 4) upward and pulling the door open.

Chair Lift Door Secure Cable

When the wheelchair access door is opened and the lift to be put in operation, the access door must be secured in the open position. The door is hinged to swing a full 180 degrees to the full open position. A cable stop is located on the interior door assembly and clipped in place on the exterior body latch ring. This cable allows the operator to ensure the door is secure during operation of the chair lift.

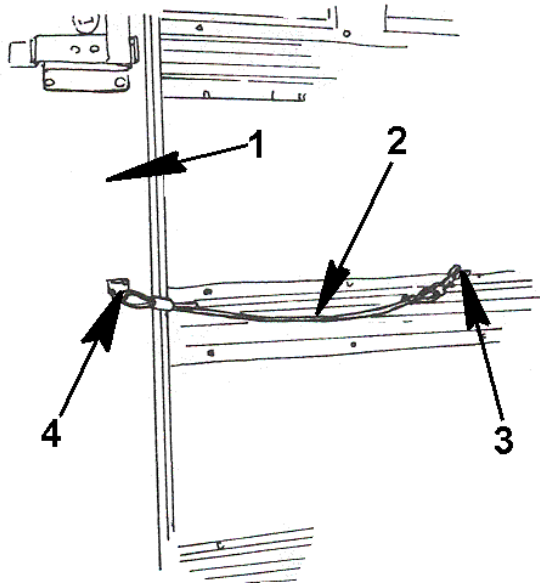

Figure 80 Chair Lift Door Cable

1. WHEELCHAIR ACCESS DOOR
2. DOOR CABLE
3. EXTERIOR BODY CABLE RING
4. DOOR CABLE RING ATTACHMENT

Wheelchair Access Door Assembly

The wheelchair access door is an external access door for use with the wheelchair lift. The door is mounted on the bus body with external swing hinges that allow a full 180 degree opening swing. The door is equipped with a door ajar warning light and buzzer that is activated when the door handle is opened. The door incorporates a full door perimeter door seal to prevent water leaks or drafts into the bus passenger area. Location of the access door is dependent upon the requirements of the specification as determined by the school district or local government agency.

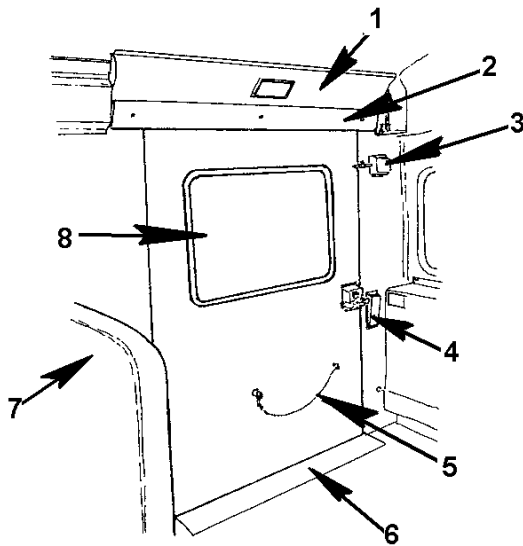

Figure 81 Wheelchair Access Door

1. WHEELCHAIR ACCESS DOOR LIGHT BAR AND LIGHT
2. DOOR HEADER CUSHION
3. INTERIOR LATCH MECHANISM (IF APPLICABLE)
4. DOOR AJAR ACTIVATION RELAY SWITCH
5. CABLE STOP ASSEMBLY
6. DOOR / FLOOR THRESHOLD
7. WHEEL CHAIR ACCESS BULKHEAD (IF APPLICABLE)
8. WINDOW AND SEAL

Door Ajar Relay Switch Assembly

The door ajar relay switch is mounted on the bus interior wall at the door opening (Fig. 82, Item 2). When the door handle is opened when the ignition key is in the on position the plunger (Fig. 82, Item 1) will activate a flashing light and or buzzer at the driver position. The door opening relay will also activate the power supply unit of the wheelchair lift unit.

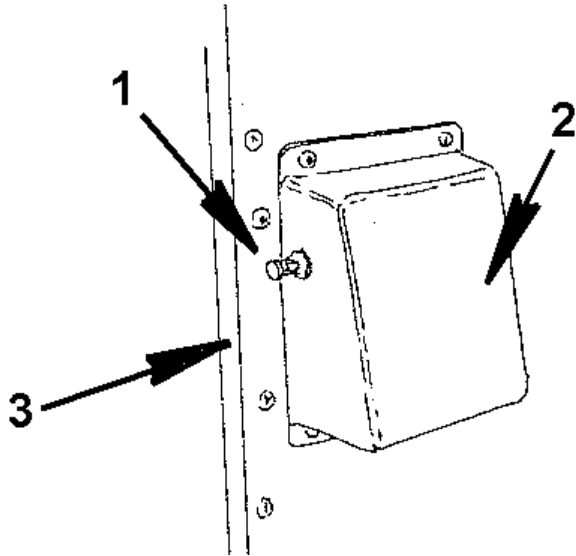

Figure 82 Door Ajar Activation Switch/Relay

1. DOOR AJAR RELAY SWITCH PLUNGER
2. DOOR AJAR / OPEN SWITCH ASSEMBLY
3. WHEELCHAIR ACCESS DOOR OPENING FRAME

Some wheelchair access doors have a positive latching pin top and bottom, controlled by the outside access handle. The pins at both the top and bottom of the latch rod secure into the threshold floor plate (Fig 83, Items 3 and 4); the upper into a bracket on the header above the door opening.

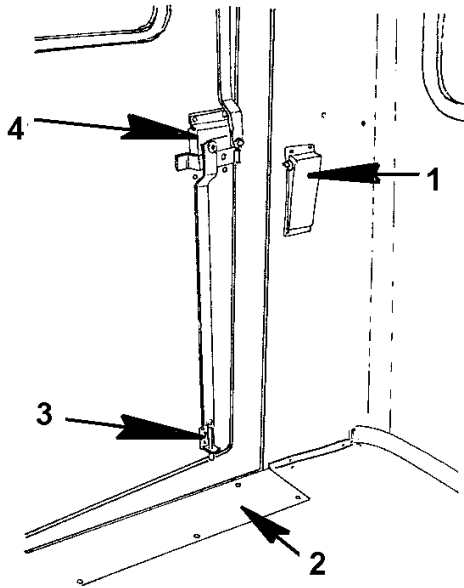

Figure 83 Wheelchair Access Door Latch Assembly (Optional)

1. DOOR AJAR ACTIVATION ALARM SWITCH
2. DOOR THRESHOLD
3. DOOR LATCH LOCK BAR (OPTIONAL 3 POINT LATCHING MECHANISM SHOWN)
4. DOOR LATCH MECHANISM

Fuel Sender Access Panel

The fuel sender access panel is located on the floor area depending on the fuel tank location. When the fuel tank is located at the rear of the bus between the frame rails the fuel sender access panel is located in the center isle section as shown (Fig. 84, Item 2).

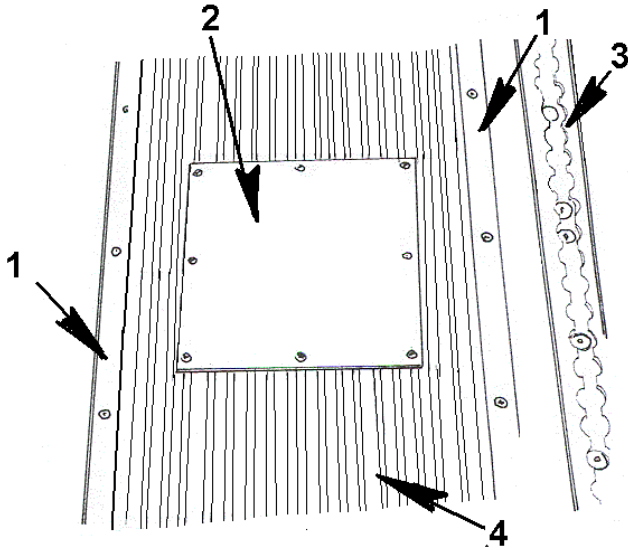

Figure 84 Fuel Sender Access Cover

1. CENTER ISLE TRIM STRIPS
2. FUEL SENDER ACCESS PANEL
3. SEAT TRACK (OPTIONAL)
4. CENTER ISLE FLOOR RUNNER

Miscellaneous Options

Miscellaneous options that may occur are listed in the paragraphs below:

First Aid Kit

The first aid kit is located in the driver area (Fig. 85, Item 2). These locations may vary depending on state and local requirements. Check state requirements for correct location. The First Aid Kit should be inspected prior to each trip.

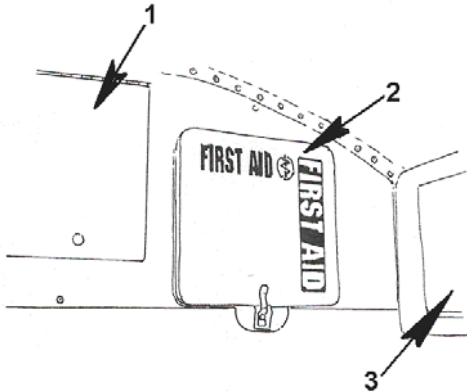

Figure 85 First Aid Kit

1. DESTINATION SIGN OR EQUIPMENT STORAGE ACCESS DOOR
2. FIRST AID KIT
3. PASSENGER DOOR OPENING MECHANISM COMPARTMENT

Body Fluid Clean-up Kit (Optional)

The body fluid clean-up kit may be mounted in various locations within the driver area (Fig. 86, Item 2). Check state requirements for application and location.

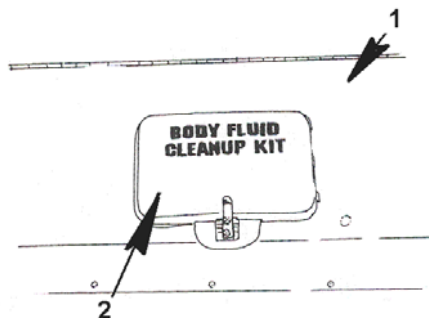

Figure 86 Body Fluid Clean-Up Kit

1. FRONT END CAP INTERIOR SKIN
2. BODY FLUID CLEAN-UP KIT

Windshield Defroster Fan (Optional)

The windshield defroster fan(s) (when specified) are located in the forward driver area (Fig. 87, Item 3) or above the entry step well. The fans are mounted on the header assembly above the windshield.

! **WARNING** – The fan motor will become extremely hot due to the ambient temperature or after operating for long periods of time. Wait until the motor cools before repositioning the fan. Use extreme care!

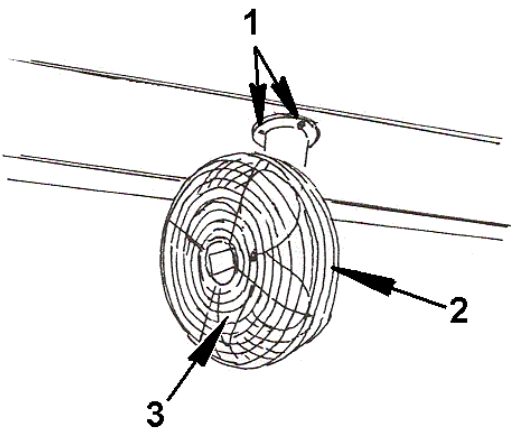

Figure 87 Windshield Defroster Fan

1. FAN MOUNTING SCREWS
2. FAN CAGE
3. DEFROSTER FAN (OPTIONAL)

Driver Side Interior Rear View Mirror and Sun Visor

The driver side interior rear view mirror and sun visor assembly are located above the driver position (Fig. 88, Item 3). The rear view mirror allows the driver to view the entire passenger section of the bus without the need to turn around. The optional translucent sun visor (Fig. 88, Item 7) is mounted on a hinged bracket attached to the windshield header assembly and is adjustable as needed by the driver.

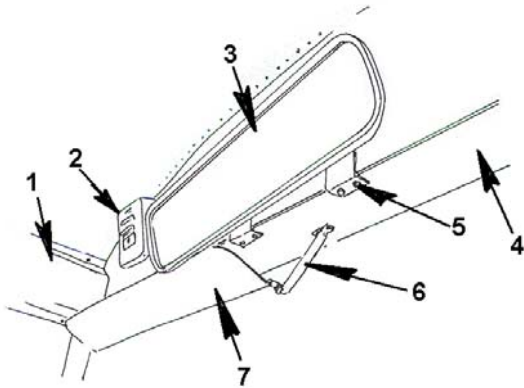

Figure 88 Interior Rear View Mirror and Sun Visor Assembly

1. DRIVER SIDE LIGHT BAR
2. EXTERIOR LIGHT MONITOR (OPTIONAL)
3. INTERIOR REAR VIEW MIRROR
4. DRIVER SIDE WINDSHIELD HEADER
5. REAR VIEW MIRROR MOUNTING BRACKET
6. SUN VISOR MOUNTING BRACKET
7. TRANSLUCENT SUN VISOR ASSEMBLY

Manual Door Opener

The manual passenger entry door opener (Fig. 89) is an option that may be required by the state or local municipality. The manual door opener assembly control handle (Fig. 90, Item 4) is located at the right wing switch panel. The door opener transverse rod is situated along the step well and attaches to the door at a mid level height.

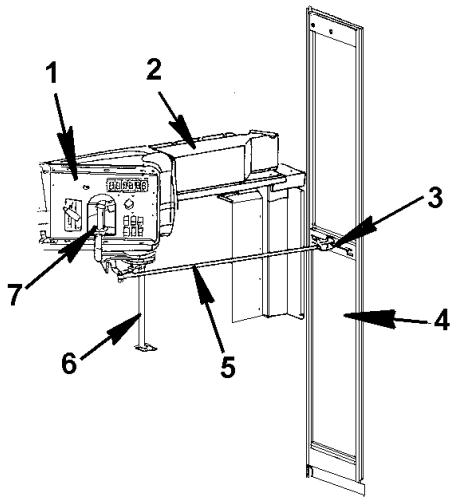

Figure 89 Manual Door Opener Operating Handle

1. BUS KEY IGNITION SWITCH
2. DEFROSTER DUCT (ENTRY PANEL REMOVED FOR DETAIL)
3. DOOR OPENER SLIDE ROD ASSEMBLY
4. FORWARD PASSENGER DOOR PANEL
5. DOOR CONTROL ROD
6. MANUAL DOOR OPENER ASSEMBLY SUPPORT LEG
7. MANUAL DOOR OPENER HANDLE AND CUT OUT

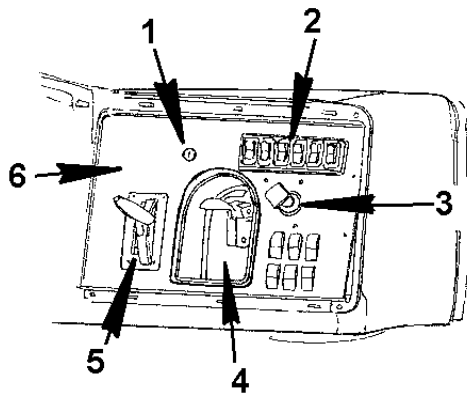



Figure 90 Manual Door Opener Transverse Control Rod

1. BUS IGNITION KEY SWITCH
2. RIGHT WING PANEL SWITCHES
3. PARKING BRAKE SWITCH
4. DOOR CONTROL HANDLE AND CUT-OUT
5. TRANSMISSION SELECTOR
6. RIGHT WING PANEL

3. REMOVE

This section describes the exterior body components and some common option removal procedures. Follow all procedures and warnings.

3.1. EXTERIOR BODY COMPONENT — REMOVE

 **WARNING** – If the owner/operator of the vehicle is a skilled technician and intends to perform the vehicle maintenance and servicing, he/she is strongly urged to purchase and follow the appropriate IC Corporation service manual. Failure to properly perform maintenance and servicing procedures could result in vehicle damage, personal injury or death.

 **WARNING** – Making any modifications to any part, component or system of the vehicle, can adversely affect the quality and reliability of your vehicle and must be avoided. Modifications to systems could result in property damage, personal injury or death.

 **WARNING** – Always use genuine International service parts. The use of inferior parts can adversely affect the quality and reliability of your vehicle, which could result in property damage, personal injury or death

Windshield Wiper Drive Arm Removal

1. Locate the windshield wiper arm assembly to be removed and swing the wiper arm out at the swivel assembly.
2. Disconnect the windshield wiper fluid supply line from the connector at the wiper arm base.

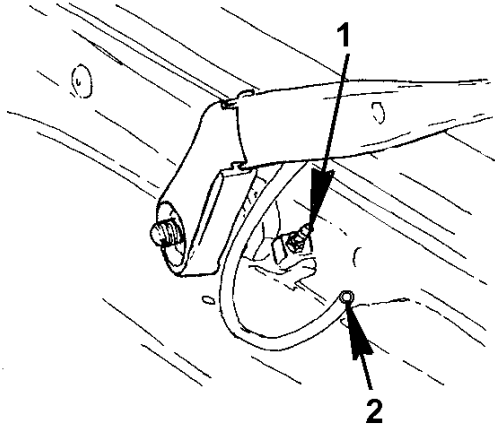

Figure 91 Windshield Washer Fluid Supply Hose

1. WINDSHIELD WASHER FLUID SUPPLY NIPPLE
2. WINDSHIELD WIPER ARM FLUID SUPPLY HOSE

3. Remove the plastic cap assembly covering the wiper arm attachment nut.

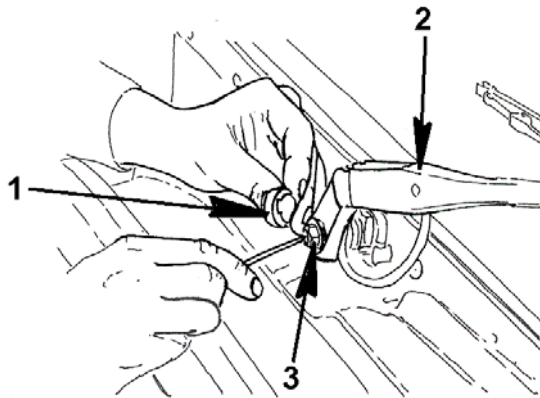

Figure 92 Wiper Arm Cap Cover

1. COVER CAP
2. WINDSHIELD WIPER ARM
3. WINDSHIELD WIPER ARM ATTACHMENT NUT

4. Loosen and remove the attachment nut.
5. Make a mark on the wiper arm assembly with a coinciding mark on the wiper drive stud. This will help in the re-alignment when re-installing the wiper arm on the drive.
6. Remove the wiper arm assembly.

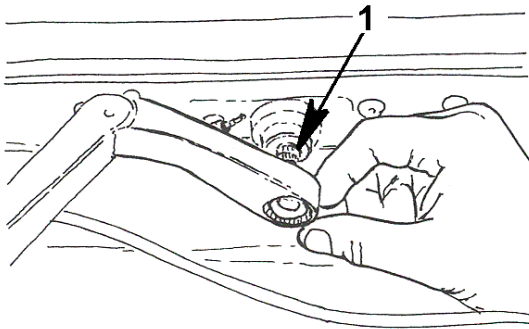

Figure 93 Windshield Wiper Arm Removal

1. WINDSHIELD WIPER DRIVE STUD

7. Follow the same procedure to remove the opposite side wiper drive arm.

Windshield Removal

IMPORTANT – There are many variations of window and glass arrangements installed in school bus applications. However, the installation and maintenance procedures given in this section can be used as a general information that is contingent on state specifications (optional equipment).

All glass in this vehicle meets F.M.V.S.S. requirements. Should the glass require replacing, replace with the same type of glass and glass mounting seal. The windshield is a flat three piece assembly. Replacing the windshield assembly requires a qualified glass technician and helper. The windshield is an AS-1 laminated safety glass, tinted 73% light transmission and sealed with a rubber “S” style gasket and lace. Installation of the windshield lace requires a special tool to properly insert and seal the windshield assembly.

NOTE – An assistant is required in the removal and installation of the windshield assembly.



WARNING – Always wear eye protection and other safety equipment when handling glass to minimize the risk of injury.

If the glass is broken, it may already have fallen or been removed from the rubber seal. It is often necessary to remove cracked or otherwise imperfect glass that is still intact. In this case, it is a good practice to criss-cross the glass with strips of masking tape before removal. This will help hold the glass together and minimize the risk of injury.

1. Beginning at the center of the windshield at the bottom glass seal, pry out the windshield lock lace from around the entire perimeter of the windshield, including the wing panels.

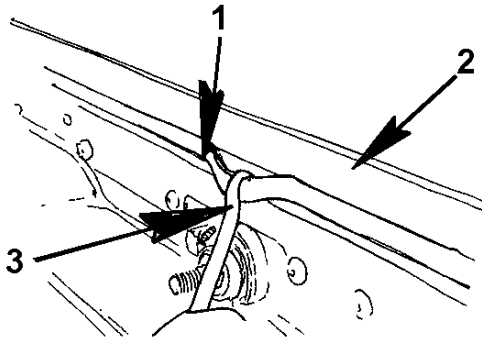

Figure 94 Windshield Lock Lace Removal

1. WINDSHIELD LOCK LACE
2. WINDSHIELD MOUNTING SEAL
3. LACE LOCK REMOVAL HOOK TOOL

2. Removal can begin at either wing panel. For easy removal a putty knife or non metallic flat tool can be use to insert between the glass and seal to release the glass from the seal.
3. While releasing the glass from the seal an assistant should apply pressure pushing the upper portion of the wing panel in an outward direction.

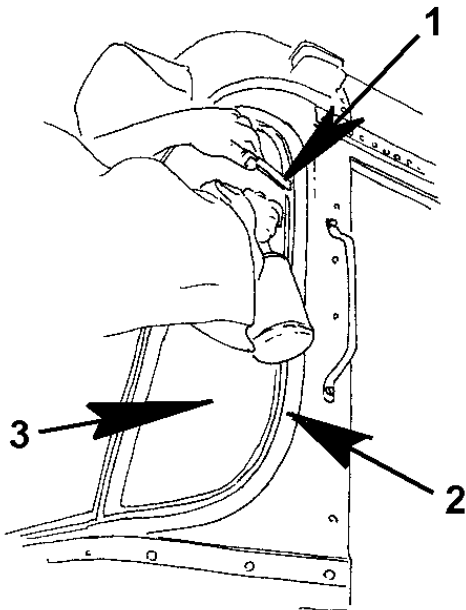

Figure 95 Wing Glass Removal

1. WINDSHIELD SEAL REMOVAL FLAT TOOL
2. WINDSHIELD MOUNTING SEAL
3. WINDSHIELD DRIVER WING PANEL

4. Remove the wing window from the seal and place on a padded table to prevent any damage.
5. Beginning in the upper corner where wing panel glass was removed, insert tool to release center glass panel from window seal. Continue across top surface of center windshield panel.

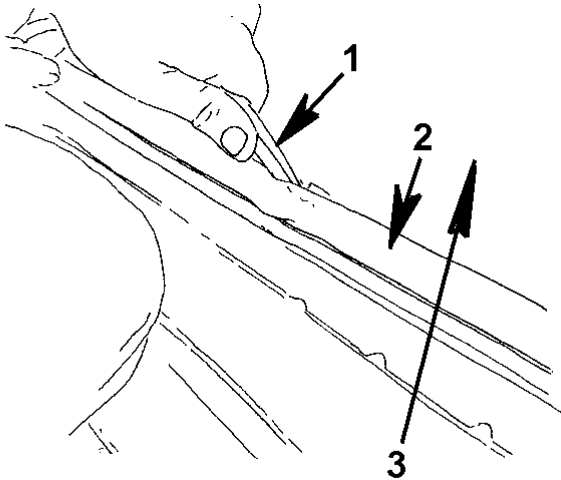

Figure 96 Windshield Center Section

1. FLAT TOOL
2. WINDSHIELD SEAL
3. WINDSHIELD CENTER PANEL

6. As the seal is being released, an assistant should be applying pressure along the upper windshield surface, pushing the glass outward.

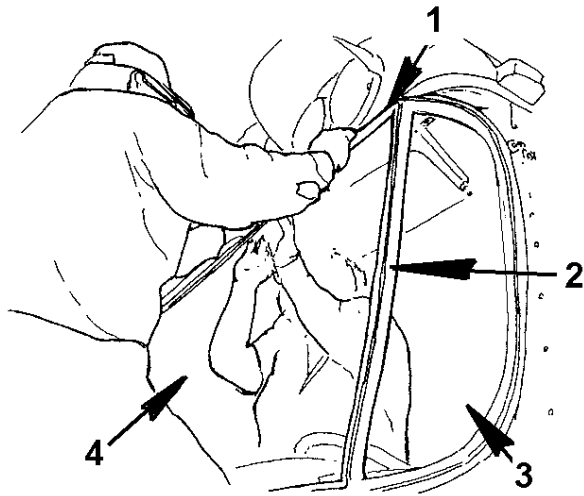

Figure 97 Windshield Remove From Seal

1. WINDSHIELD TOP SEAL SECTION
2. VERTICAL SEAL (DRIVER SIDE SHOWN)
3. DRIVERS WING PANEL GLASS
4. WINDSHIELD CENTER GLASS

7. When the windshield and seal have been released from the windshield frame assembly at the top of the windshield, remove the vertical seal from the outboard edge of the glass. The assistant should be steadying glass during procedure removing the windshield seal.
8. Remove the seal from the upper edge of the center windshield glass.
9. With an assistant slide the glass toward the side of the bus (the side with wing panel previously removed), lift glass out of bottom seal, and remove from bus.

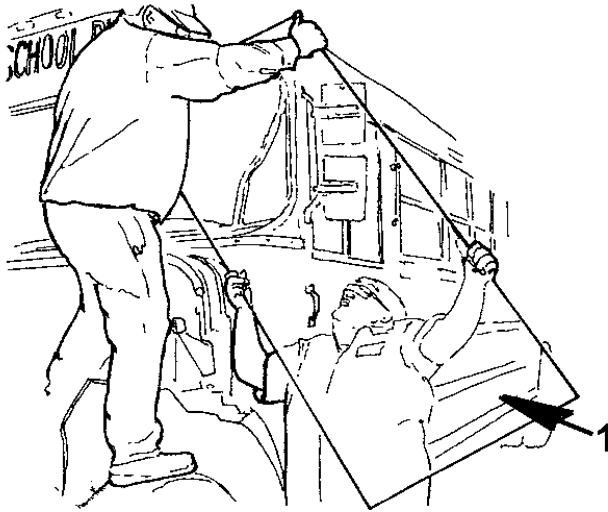

Figure 98 Windshield Removal

1. WINDSHIELD CENTER PANEL

10. If windshield glass is going to be re-used (not broken or cracked) store on padded stand until ready to install.
11. Check windshield mounting frame and tabs for any damage before installing new seal and or glass.

Rear View Mirror- Driver Side

The driver side rear view mirror is a body mounted mirror forward of the drivers window. The mirror is mounted on a bracket below the drivers window plane.

1. To remove the drivers exterior rear view mirror, locate the four mounting bolts attaching the bracket to the bus body.

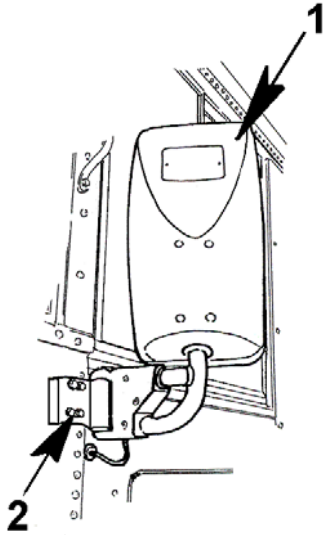

Figure 99 Driver Side Rear View Mirror

1. DRIVER SIDE REAR VIEW MIRROR HEAD ASSEMBLY
2. DRIVER SIDE REAR VIEW MIRROR MOUNTING SCREWS

2. If mirror head is equipped with mirror heaters, disconnect the harness connection.
3. Access the harness connection plugs in the electrical compartment below the drivers window assembly. Remove the body grommet prior to pulling mirror harness through body opening.
4. Remove mirror.

Rear View Mirror- Passenger Side

Locate the passenger side mirror brackets.

A ladder will be required to remove the passenger side mirror assembly.

1. Loosen and remove the mirror bracket arm from mirror main support.

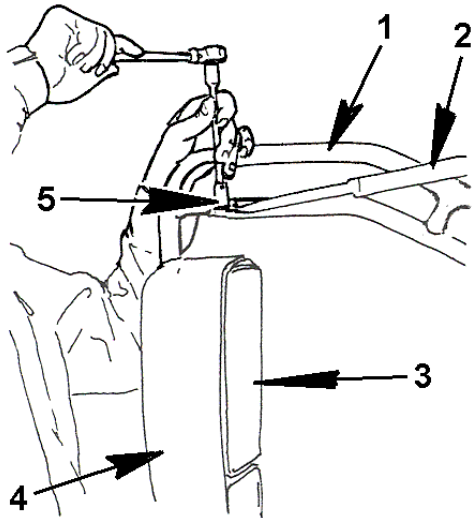

Figure 100 Passenger Side Rear View Mirror-Removal

1. PASSENGER SIDE REAR VIEW MIRROR MAIN SUPPORT ARM
2. PASSENGER SIDE REAR VIEW MIRROR LATERAL BRACKET
3. PASSENGER SIDE REAR VIEW MIRROR UPPER PANEL
4. PASSENGER SIDE REAR VIEW MIRROR HEAD
5. PASSENGER SIDE REAR VIEW MIRROR LATERAL BRACE MOUNTING CLAMP AND MOUNTING NUT AND BOLT

2. Swing mirror outward to access all four mounting bolts on door and window external pillar.
3. To access the mirror heater element connection, locate the "A" pillar cover on the inside of the bus entry at the windshield.
4. Remove the mounting screw cover caps, loosen and remove the "A" pillar cover mounting screws. Remove the pillar cover.
5. Disconnect mirror heater harness (if applicable).
6. Loosen and remove mirror mounting bracket at mirror swing out base.
7. Remove mirror assembly.

Front Warning Lights

The front warning lights mounted on the upper front cap section are replaceable; the lens can be removed to replace burned out bulbs.

1. Utilizing a step ladder or stand, locate the light to be replaced, or bulb (incandescent bulbs) to be changed. With LED lights, the entire light must be replaced.
2. Locate the lens mounting screws on the light, loosen and remove.

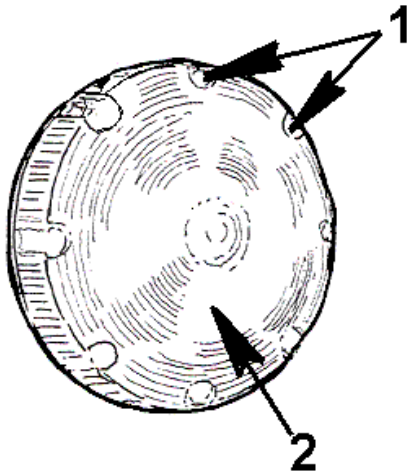

Figure 101 Front Warning Lights (Typical)

1. WARNING LIGHT LENS MOUNTING SCREWS
2. WARNING LIGHT LENS

3. Remove the lens cover and gasket if applicable.
4. Remove bulb if replacement is necessary.
5. To remove light assembly, locate the mounting screws securing light fixture to bus body. Loosen and remove mounting screws.
6. Disconnect light connection plug and remove light.
7. Check wire grommet in surface of body prior to installing new light.
8. Follow same procedure for other lights that may have to be changed or replaced.

Destination Sign Lighted (Optional)

The backlit glass destination sign may be removed if broken. Access to lighting of destination board is from interior of bus above windshield header. The procedure for removal of the glass destination board is as follows:

1. Open the hood of vehicle (wheels should have been previously chocked and parking brake applied).
2. Using a straight plastic flat tool, release the lace from the destination sign mounting rubber seal.
3. Remove the lace.
4. Carefully remove broken glass on destination sign if applicable. A cover should be utilized to cover engine and component parts from broken glass that may separate during removal of glass destination board.
5. Remove destination glass seal ("H" seal).

6. Discard the seal if necessary and replace with new.
7. Follow same procedure for rear destination board if required.

D.O.T. Lights and Reflectors

D.O.T. marker lights and reflectors are located in various positions around the body.

1. Remove lens on marker light to access bulb for replacement.
2. Loosen and remove lens mounting screw in center of lens assembly.

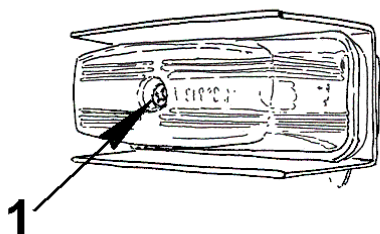

Figure 102 D.O.T. Light Removal

1. LENS AND LIGHT MOUNTING SCREW

3. Replace bulb as necessary.
4. Reflectors are replaceable by removing the center screw.

Vandal Lock

The vandal lock option is located forward of the side entry door below the passenger side windshield wing panel. To remove the vandal lock assembly the passenger side of the dash panel must be removed.

1. Beginning at the passenger side wing panel glass, locate the mounting screw and tab for the passenger entry dash panel.
2. Remove the mounting screws on the forward, leading edge of the dash panel assembly.

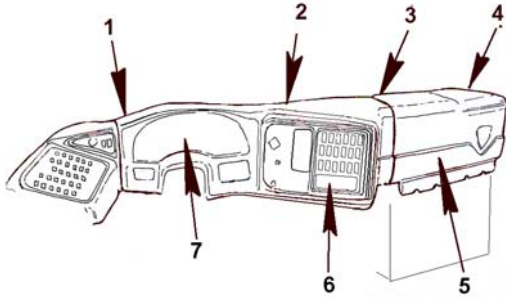

Figure 103 Dash Panel Remove to Access Vandal Lock

1. DASH PANEL FORWARD EDGE MOUNTING SCREW LOCATION
2. WING PANEL AND CLUSTER MOUNTING SCREW LOCATION
3. RIGHT WING PANEL AND ENTRY MOUNTING SCREW LOCATION
4. ENTRY STEP WELL DASH MOUNTING SCREW
5. ENTRY WELL DASH PANEL SECTION
6. RIGHT WING SWITCH PANEL SECTION
7. CLUSTER SECTION

3. Locate the mounting screws along the bottom edge of the dash panel and remove.
4. Lift the dash panel up and out of the way.
5. Locate the vandal lock assembly on the interior panel forward of the passenger entry and over the cross bus beam.
6. Disconnect the wire connections to the vandal lock assembly.

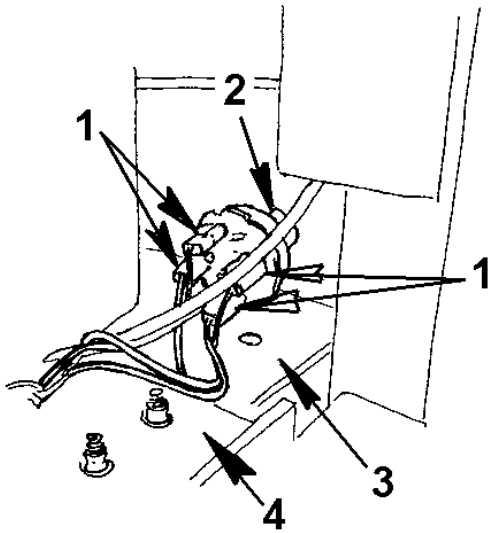

Figure 104 Disconnect Wire Connections- Vandal Lock

1. VANDAL LOCK HARNESS CONNECTORS
2. VANDAL LOCK INTERIOR JAM NUT
3. CROSS BEAM SUPPORT MOUNTING BRACKET
4. CROSS BUS BEAM ASSEMBLY

7. Loosen the vandal lock interior surface lock jam nut.
8. Loosen and remove the exterior trim ring on vandal lock key shaft.
9. Loosen the lock ring on the outside body panel section of the vehicle, remove the nut and washer.
10. Remove the vandal lock assembly out of the mounting hole from inside.

Assist Steps

Assist steps are located each side of the bus behind the fender extension. The steps are a fold down access step to aid in access to windshield wipers and blades. The steps are removable.

1. Locate the step to be removed, fold to down position to access upper mounting bolt.

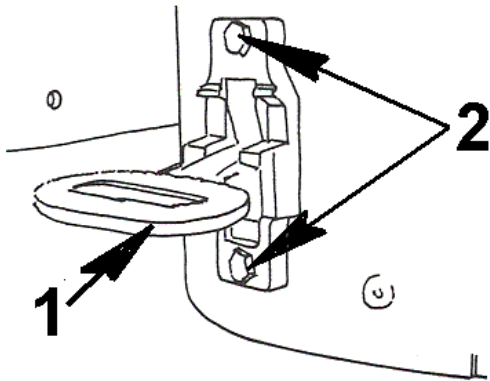

Figure 105 Assist Steps Remove

1. FOLD DOWN ASSIST STEP
2. ASSIST STEP MOUNTING BOLTS

2. Loosen and remove upper and lower mounting bolt, remove step assembly.

Passenger Entry Door

The side exit door should be inspected daily for proper operation, as stated by the instruction decal. Inspect the door seal on each door for foreign debris and dirt accumulation from road film and other environmental factors. Over a period of time, door seal rubber can lose its elasticity and become brittle. A thin coat of lubricant such as Vaseline will restore the natural characteristics of the seal.

The passenger entry doors are a double door assembly, with mounting points in the upper and lower corners of each door. The standard entry doors are electrically operated. Disconnect the harness connection to the door operating mechanism prior to removing the doors, or set door control switch in panel over door to manual mode.

1. Disconnect the drive arm mounting bolts at the top of each door.

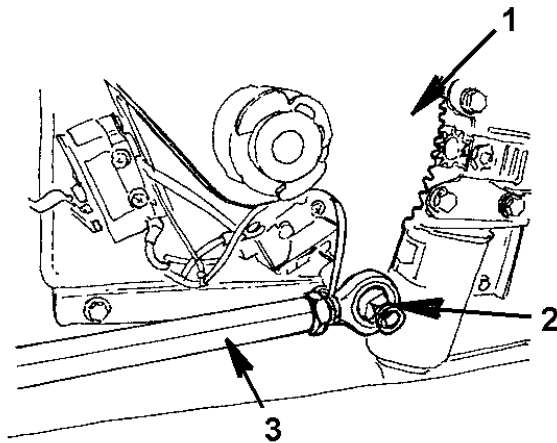

Figure 106 Drive Arm Disconnect

1. DOOR OPENER GEAR DRIVE PLATE
2. DOOR OPENER DRIVE ARM MOUNTING BUSHING AND CONNECTOR
3. DOOR OPENER DRIVE ARM

- Loosen and remove the mounting bracket bolts and remove the bushing and bracket from the door jam assembly. An assistant should be available to steady door when removing the lower mounting bracket and bushing.

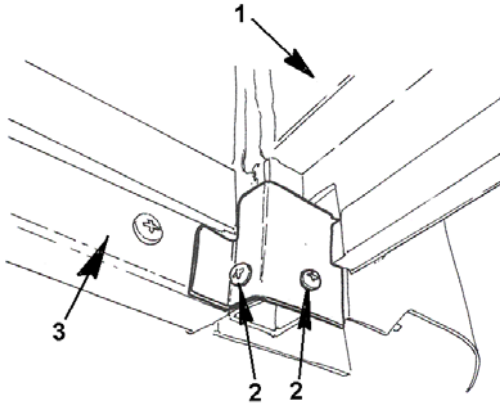

Figure 107 Passenger Entry Door Pivot Bracket (Right Hand shown)

- FORWARD PASSENGER ENTRY DOOR PANEL
- PIVOT BLOCK MOUNTING SCREWS
- ENTRY STEP LOWER SUPPORT BAR

- Lower the door from the upper mounting hole opening.
- Set door down in secure out of the way area to avoid possible glass damage.
- Follow the same procedure for the opposite side entry door.

Fuel Fill

The bus fuel fill is located on the curb side of the vehicle unless optional tanks are required and installed. The fuel fill location on side mounted fuel tanks is generally located behind the passenger side entry door. Rear mounted between the frame rail fuel tanks have the fuel fill door at the rear of the bus body behind of the rear axle. The fuel door has a positive latching device to secure the door. An optional locking door is available. The entire fuel fill access door assembly can be removed.

- Locate the six mounting screws that secure the fuel fill door assembly to the body side panel.

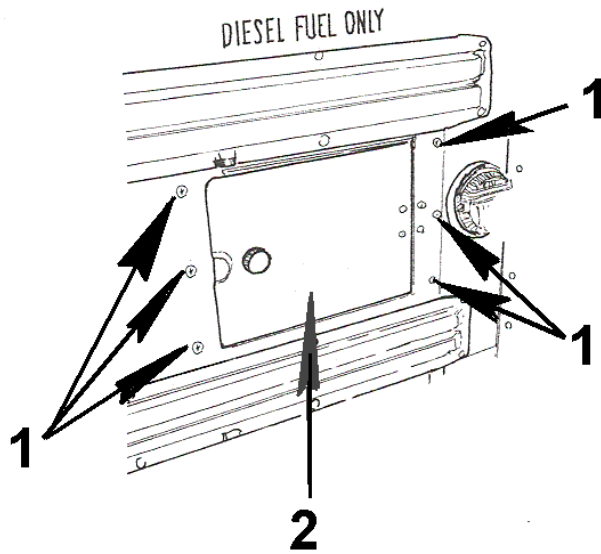

Figure 108 Fuel Fill Door Panel Removal

1. FUEL DOOR PANEL MOUNTING SCREWS
2. FUEL PANEL DOOR

2. Loosen and remove the mounting screws and remove fuel fill door assembly.

Passenger Windows and Emergency Exit Windows

Passenger windows and emergency exit windows are removed from inside the bus body. All repairs or servicing of the windows and glass is addressed in the interior remove section of this service manual.

Emergency Exit Doors

Depending on the wheelbase, the type of seating requirements and/or the state specifications, the location of the emergency exit door may vary from side to side and rear. The emergency exit door utilizes a hidden door hinge. The hidden door hinges are protected from inclement weather and road chemicals that might cause corrosion.

The emergency exit door(s) should also be inspected daily for proper operation. The door buzzer should be checked with the ignition switch in the "ON" position. If the door buzzer sounds after the door has been closed, check the door switch adjustment and electrical install to determine the cause of the problem. The door switch will require an adjustment in or out to eliminate the problem.

Inspect the hold back device and the mounting hardware torque for distortion at regular intervals. All emergency exits should be inspected and operated per operational instruction labels daily.

1. To remove the emergency exit door, the ignition key should be in the off position.
2. Lift latch arm and open door.

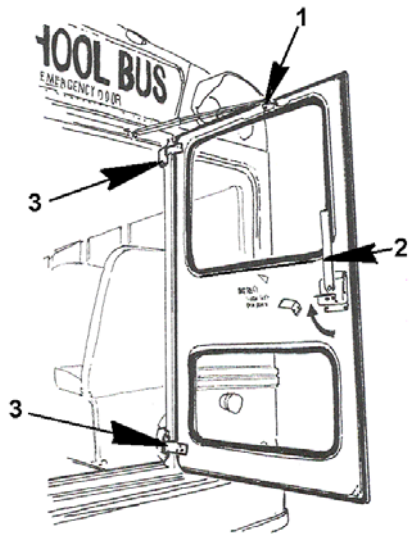

Figure 109 Emergency Exit Door Assembly

1. EMERGENCY EXIT DOOR STAY
2. EMERGENCY DOOR EXIT INTERIOR EXIT DOOR LATCH
3. EMERGENCY EXIT DOOR HIDDEN HINGE ASSEMBLY

3. Locate and remove the mounting bolts on the door hold back device, located at the top of the exit door and door frame.

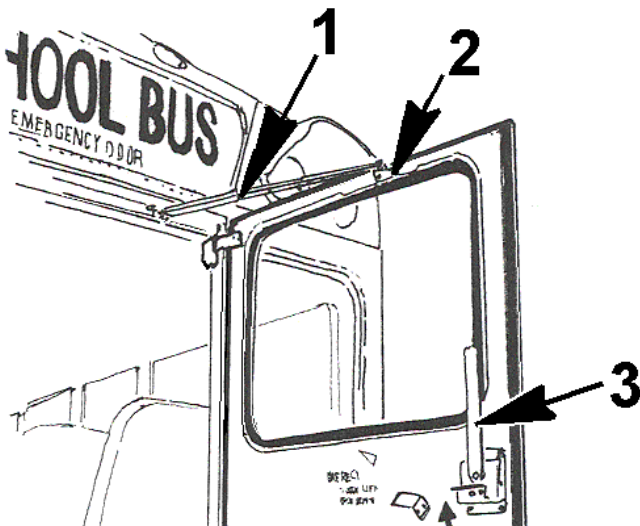

Figure 110 Door Hold Open Device

1. EMERGENCY DOOR HOLD OPEN DEVICE
2. HOLD OPEN DEVICE MOUNTING BRACKET
3. EMERGENCY DOOR INTERIOR EXIT LATCH HANDLE

4. Locate and remove the plastic hinge covers.
5. Locate the door / hinge mounting bolts.
6. Loosen and remove mounting bolts; an assistant should be available to help remove the emergency exit door.

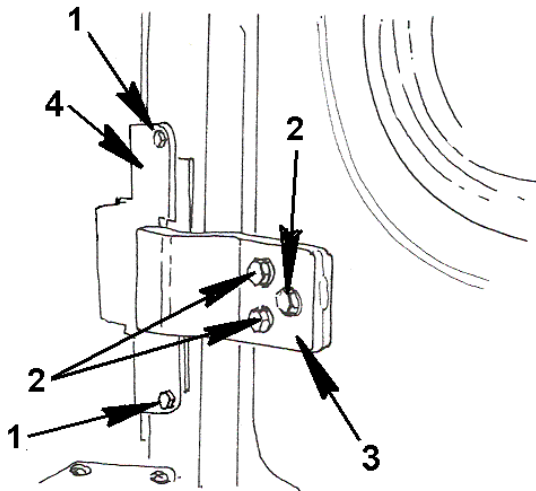

Figure 111 Emergency Exit Door Hinge and Bolt Removal

1. EMERGENCY EXIT DOOR FRAME MOUNTING BOLTS
2. DOOR HINGE MOUNTING BOLTS
3. DOOR HINGE ASSEMBLY
4. FRAME MOUNTED HINGE PLASTIC COVER PLATE

Roof Mounted Escape Hatch

All roof hatches installed are designed to provide years of reliable service with a minimum of maintenance. All components are corrosion resistant with lifetime finishes, and moving parts are Teflon coated to eliminate the need for lubrication. Use of lubricants, paints or other coatings — such as graffiti deterring sprays — is not recommended on roof hatches. The alarm switch should be inspected daily for proper operation. The audible warning buzzer should activate when the hatch door is open, with the ignition switch “on”. The instructional decal to open the hatch should be near the release handle at all times.

If the roof hatch is damaged in any manner, removal and replacement must be undertaken.



WARNING – To avoid personal injury or death always use a secure scaffold assembly and safety restraints or equivalent equipment when servicing the bus roof panels or roof component accessories. An assistant should be present during any roof or roof accessory repair procedures.

1. To remove the roof hatch, locate the roof hatch assembly interior trim collar. Locate the trim caps covering the mounting screws around the perimeter of the interior trim ring.

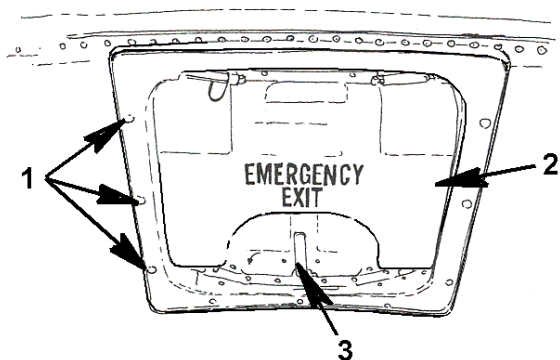

Figure 112 Roof Hatch Interior Mounting Ring

1. INTERIOR HATCH MOUNTING SCREW COVER CAPS
2. EMERGENCY HATCH ASSEMBLY
3. HATCH EXIT ACTIVATION HANDLE

2. Remove the cap covers.
3. Loosen and remove the mounting screws securing the trim ring to the ceiling and roof hatch assembly.
4. Locate and disconnect the electrical harness connection for the hatch open buzzer indicator.
5. On the top of the roof section, locate the rivet cap covers around the outside perimeter of the roof hatch assembly.

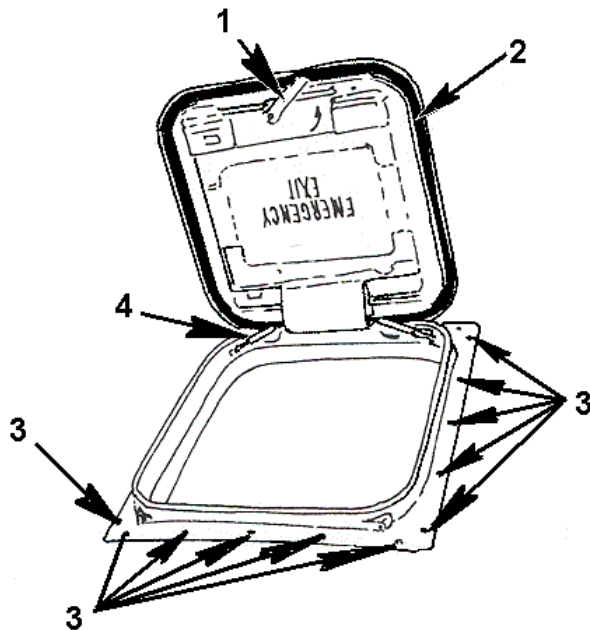

Figure 113 Emergency Roof Hatch Removal

1. HATCH EXIT ACTIVATION HANDLE
2. HATCH WEATHER SEAL
3. HATCH ROOF ASSEMBLY MOUNTING HOLES
4. HATCH HOLD OPEN CYLINDERS

6. Remove the caps that cover the hatch mounting screws. Loosen and remove the hatch mounting screws.
7. With the screws removed, lift the escape hatch assembly from the roof section.
8. Check for sealer material on the surface of the bus roof around the hatch assembly opening.
9. Remove any sealer or gasket material around the opening and clean the surface prior to installation of the roof hatch assembly.

Wheelchair Access Door

The wheelchair lift door is a flush mounted access door with three exterior hinge assemblies.

1. To remove the wheelchair access door, locate and open the door latch assembly.
2. Locate the exterior hinge assembly mounting bolts on the bus body and loosen the mounting bolts in each hinge.

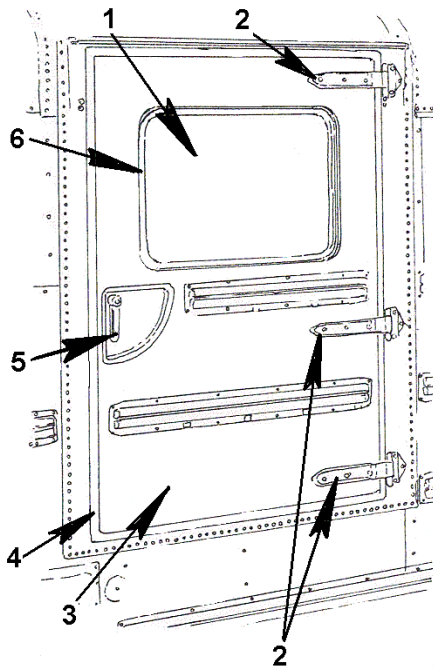

Figure 114 Wheel Chair Access Door Hinge Removal

1. WHEEL CHAIR DOOR WINDOW ASSEMBLY
2. WHEEL CHAIR ACCESS DOOR HINGES
3. WHEEL CHAIR ACCESS DOOR ASSEMBLY
4. WHEEL CHAIR DOOR SEAL
5. WHEEL CHAIR ACCESS DOOR OPENING LATCH HANDLE
6. ACCESS DOOR WINDOW SEAL

3. With an assistant, remove the mounting bolts, and remove the door assembly.
4. Place the door on a padded stand or table to complete any further repairs that may be required to the door assembly.

Rear Bumper Assembly

The rear bumper assembly is a steel bumper bolted to the chassis frame section offset with mounting brackets. The bumper is mounted to the brackets with eight carriage bolts with lock nuts and washers.

1. Locate, loosen and remove the mounting screws securing the bumper transition cover on the body panels and bumper ends.

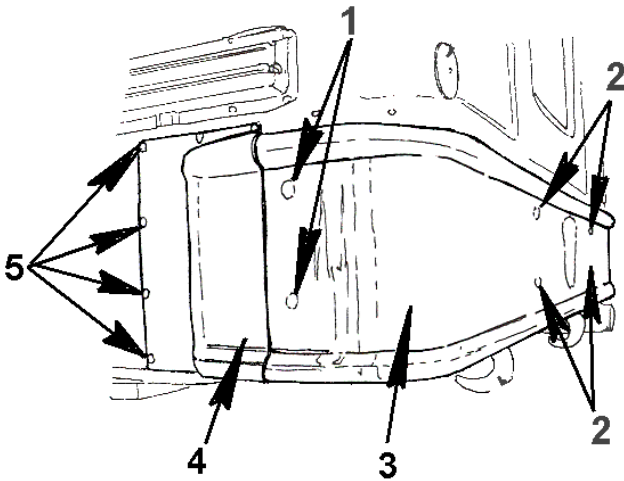

Figure 115 Bumper Transition Cover

1. REAR BUMPER SIDE MOUNTING BOLTS (2 EACH SIDE)
2. REAR BUMPER MOUNTING BOLTS (4)
3. BUS REAR BUMPER ASSEMBLY
4. BUMPER TRANSITION COVER
5. BUMPER TRANSITION COVER MOUNTING SCREWS

2. Locate the bumper mounting bolts and lock nuts and washers on the bumper assembly. These bolts are located on the outboard section of the bumper assembly on each side at the rear of the bus body.

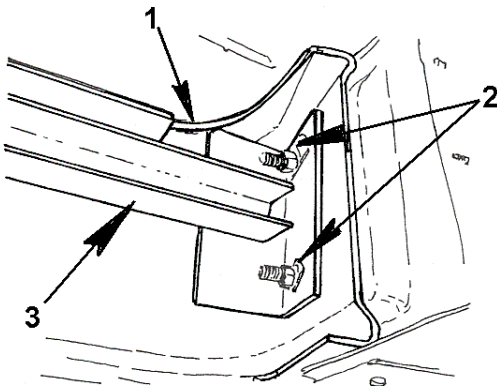

Figure 116 Rear Bumper Side Support Brackets (DRIVERS SIDE SHOWN)

1. REAR BUMPER ASSEMBLY
2. REAR BUMPER SIDE MOUNTING BOLTS
3. REAR BUMPER SIDE SUPPORT BRACKET ASSEMBLY

3. Loosen and remove the lock nuts and washers (2 each side) securing the bumper assembly to the mounting brackets on the bumper mounting assembly located outboard each side of the body.

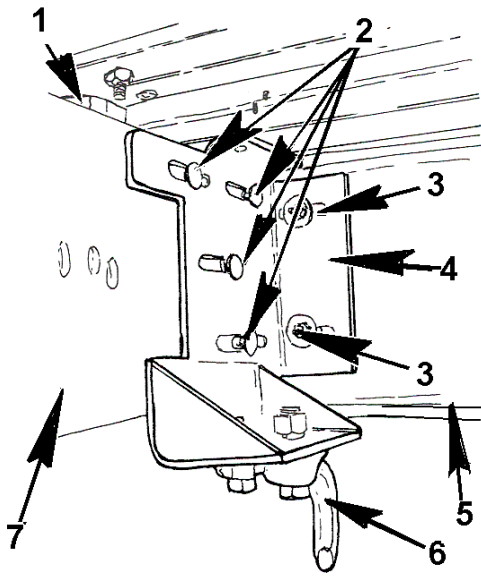

Figure 117 Bumper Mounting Bracket and Bolts with Tow Hook Assembly

1. SQUEAK PAD
2. BUMPER FRAME MOUNTING BRACKET BOLTS
3. REAR BUMPER MOUNTING BOLTS, NUTS AND WASHERS
4. REAR BUMPER MOUNTING BRACKET
5. REAR BUMPER LOWER FLANGE SECTION
6. REAR TOW HOOK ASSEMBLY (OPTIONAL)
7. CHASSIS FRAME SECTION

4. With an assistant steadying the bumper, loosen and remove the remaining 4 mounting bolts at the rear of the bumper assembly from the bumper mounting brackets.
5. Remove the rear bumper assembly.

Rear Body Exterior Lights and Warning Lights

The exterior lights and warning light assemblies and lenses at the rear of the bus body may be totally removed due to damage.

1. Bulb replacement is done by removing the eight lens mounting screws on the applicable light, removing the lens and seal and replacing bulb.
2. The entire light fixture may be removed by removing the lens (step 1), and locating the light fixture mounting screws

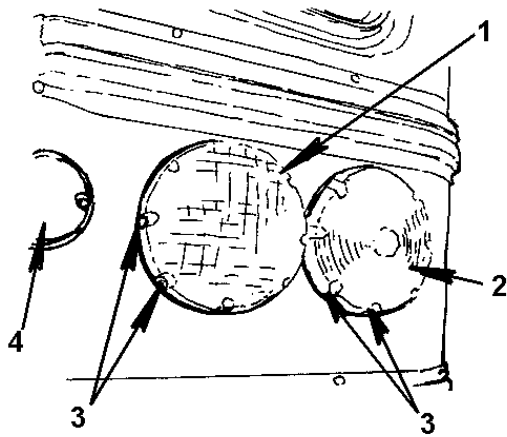

Figure 118 Typical Light Removal

1. STOP / TAIL LIGHT ASSEMBLY
2. AMBER DIRECTIONAL LIGHT ASSEMBLY
3. TYPICAL MOUNTING SCREWS
4. STANDARD BACK-UP LIGHT

3. Remove the mounting screws, disconnect the light harness plug and remove light fixture.

NOTE – If equipped with L.E.D. lights and light burns out, the entire assembly must be replaced.

Street Side Stop Signs

To remove street side stop signs located on the side of the bus body below driver side window, or the optional rear driver side body mounted stop arm or sign, follow the procedure as described. Stop sign lights may vary according to the requirements as specified by the municipality or school district. The optional lights may be either strobe or L.E.D. type.

1. If only replacement bulbs are needed in the stop arm sign, the lens should be removed and bulb replaced. Replace bulbs with the proper style and bulb designation as required by the manufacturer.
2. To remove the entire stop arm assembly, locate the two front mounting screws on the swing arm bracket.

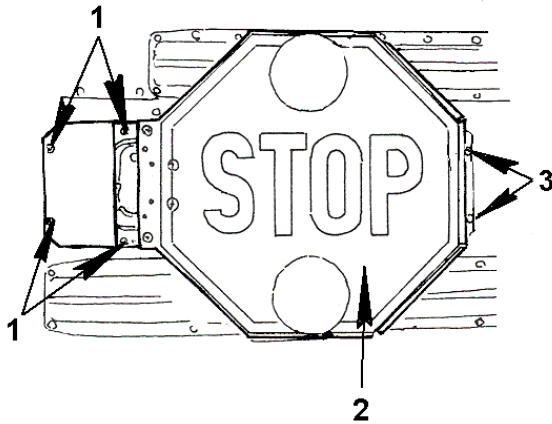

Figure 119 Stop Arm Assembly Front Mounting Screws

1. STOP ARM FORWARD MOUNTING SCREWS
2. STOP ARM SIGN ASSEMBLY
3. STOP ARM REAR MOUNTING SCREWS

3. Loosen and remove the lower screw, then loosen the upper screw.
4. Disconnect cable pull on the sign assembly and remove the cotter pin.
5. Swing the sign to the open position. Locate the rear mounting screws on the swing sign assembly.
6. Loosen the upper and lower screws, then remove the lower screws.

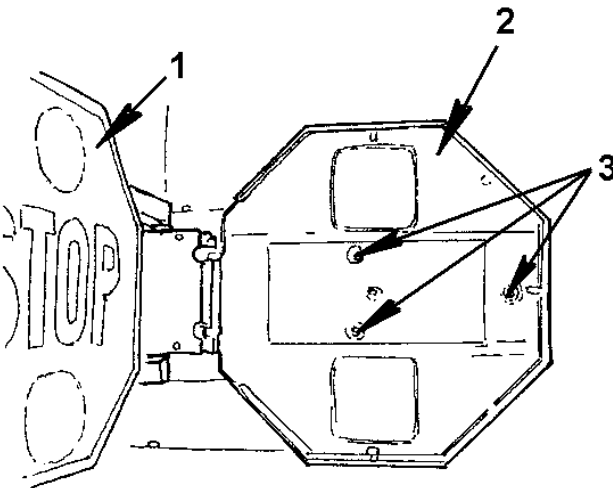

Figure 120 Rear Stop Arm Mounting Screws (Optional Sign Assembly)

1. REAR STOP ARM SIGN ASSEMBLY
2. STOP ARM SIGN BACKING PLATE
3. STOP ARM MOUNTING SCREWS

7. With an assistant holding the assembly, remove the upper mounting screws.
8. Disconnect the stop sign / arm assembly harness plug and remove the stop sign / arm assembly.

Rubber Fenderettes

The rubber fenderettes help decrease the amount of mud and water splash from the rear wheels. The rubber fenderettes are available as an optional item.

Use the procedure to remove the fenderettes.

1. Locate the 21 mounting screws and lock nuts around the wheel well opening securing the rubber fenderette and mounting ring.

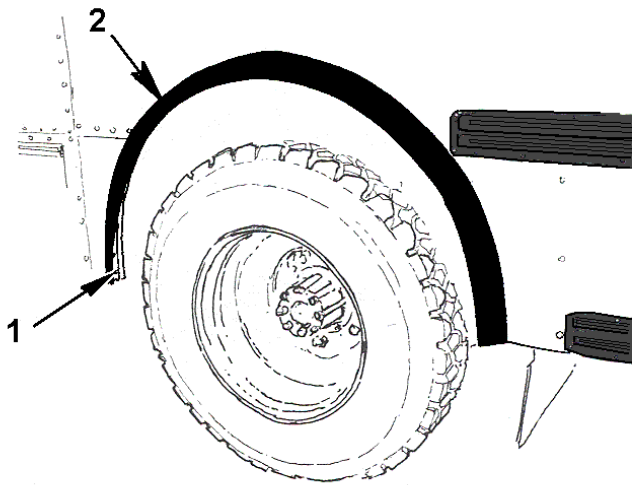

Figure 121 Rubber Fenderette Mounting Screws

1. FENDERETTE MOUNTING BOLT
2. FENDERETTE ASSEMBLY

2. Loosen and remove the mounting screws and lock nuts.
3. Remove the mounting ring and fenderette.
4. Check the mounting holes for any rust or damage.

Under Body Compartments

The luggage boxes or underbody compartments are located along the lower line of the body and attached to the floor structure flange sections. The front face of the compartment door frame is on the side sheet and attached with mounting screws (Fig. 27, Item 2). The luggage compartment has luggage box hanger brackets attached to the rear of the compartment upper surface with a “J” clip assembly clipped to the frame rail upper flange. The luggage box mounting brackets are welded to the rear wall of the luggage compartment. The upper flanges of the luggage compartment are spot welded to the floor structure lower flange. The number of luggage box mounting brackets may vary depending on the overall length of the compartment.

1. To remove the under body storage / luggage box compartment, place jack stand supports under the compartment in preparation for compartment removal.
2. Prior to removing the underbody luggage compartment the compartment door may be removed. (See steps 11–14)
3. With a grinder carefully grind the spot welds at the compartment top flanges and floor structure lower flange.
4. With all the welds removed check the floor structure flange for undercoating or other debris. Make sure the flange surface is clean and smooth.
5. Locate the mounting screws along the face frame of the compartment door.
6. Loosen and remove the mounting screws.
7. Remove the front face plate of the luggage compartment.

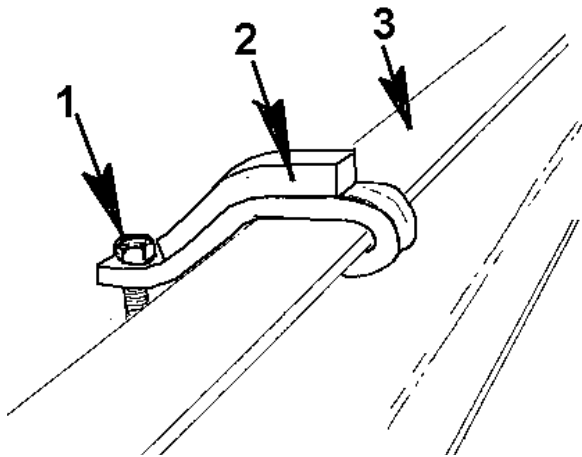

Figure 122 “J” Clip Mounting

1. COMPARTMENT FASTENING ATTACHMENT BOLT
2. “J” CLIP WITH REINFORCING
2. TOP OF FRAME RAIL (DRIVERS SIDE SHOWN)

8. Locate the luggage box hanger brackets and “J” clip mounting bolts and nuts at the rear of the compartment.
9. Loosen and remove the luggage box “J” clip attachment mounting nuts and bolts.
10. With an assistant lower the compartment support jack stands and remove compartment from bus body.

Under Body Compartment Door Removal

The under body luggage compartment door can be removed without removal of the entire under body compartment. The under body compartment door hinge is a single piece extruded rubber hinge that runs the full length of the door opening.

11. To remove the underbody compartment door, unlatch the door lock mechanism and swing door upward.

12. With an assistant, slide the door assembly from rubber extruded door hinge. Remove the door when the hinge and the door have been disconnected.
13. The hinge may then also be removed from the compartment frame extrusion by sliding the hinge out of the extrusion.

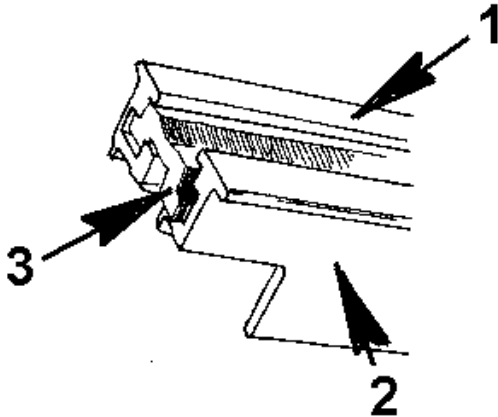

Figure 123 Under Body Compartment Hinge Assembly

1. UPPER SIDE HINGE SECTION (BODY)
2. LOWER SIDE HINGE SECTION (DOOR)
3. RUBBER HINGE ASSEMBLY

14. Check the rubber extruded door hinge for cracks or breaks and replace if necessary.

Electrical Compartment

The body electrical access door is mounted utilizing two hidden hinges attached to the door panel assembly. The door also includes a recessed full wraparound door seal.

1. The door may be removed by locating and removing the mounting nuts and screws on the door hinge mounting plate.

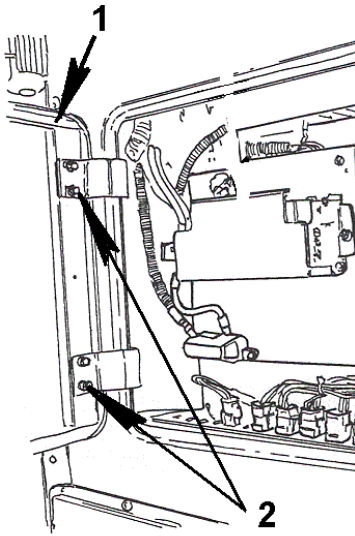

Figure 124 Electrical Compartment Door Remove

1. ELECTRICAL COMPARTMENT DOOR ASSEMBLY
2. HINGE/DOOR MOUNTING NUTS

2. The door seal should be checked for cracks or breaks that might allow dirt and or moisture to get into the electrical control panel. Replace seal if cracks or breaks are identified.

Battery Compartment

The battery compartment incorporates a hinged, sealed latching door and slide out battery tray. The battery tray is equipped with battery tie down clamps and a positive latch handle to secure the battery tray in place. The battery compartment structure is welded in place at the compartment upper flanges and the floor structure lower flanges.

1. The battery compartment door and frame assembly are bolted to the body side skin, with the hinge assembly bolted to the door frame assembly.
2. Open the battery compartment door and disconnect the cable stop on the door panel.

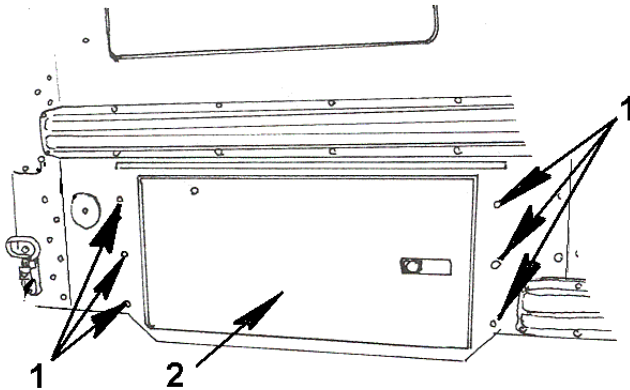

Figure 125 Battery Compartment Door Removal

1. BATTERY COMPARTMENT FRONT FACE MOUNTING RIVETS
2. BATTERY COMPARTMENT DOOR ASSEMBLY

3. Loosen and remove the door frame panel. The door hinge is riveted to the door frame assembly.
4. If the door has been damaged drill out the rivet heads. Remove rivet bodies and remove door.
5. To remove the compartment, with a grinder carefully grind the spot welds at the compartment top flanges and floor structure lower flange.
6. With all the welds removed check the floor structure flange for undercoating or other debris. Make sure the flange surface is clean and smooth.
7. Remove the compartment.

Radio Antenna

The entertainment radio antenna is mounted on the bus body pillar directly behind the driver side sliding window.

1. Loosen and remove the retainer nuts on the antenna mounting posts.

Transition Panels

The transition panel and reinforcing bar are fastened to the bus cowl section. A yellow adhesive sealer may be utilized in the installation of the transition panels. This sealer must also be removed and the areas cleaned prior to the installation of the new transition panel, if applicable.

1. To remove the transition panel, locate the upper and lower mounting screws, 4 at the top and two at the bottom.

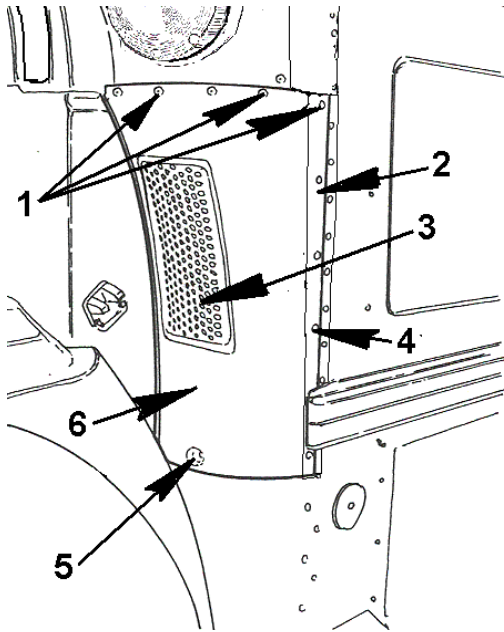

Figure 126 Transition Panel Remove

1. TRANSITION PANEL MOUNTING SCREWS
2. TRANSITION PANEL REINFORCING FLAT BAR
3. DRIVER SIDE FRESH AIR INLET PANEL
4. REINFORCING BAR MOUNTING SCREWS
5. LOWER TRANSITION PANEL MOUNTING BOLT
6. TRANSITION PANEL (DRIVERS SIDE SHOWN)

2. Loosen and remove the mounting screws.
3. Locate the vertical transition panel mounting bracket, loosen and remove the mounting screws.
4. Remove the transition panel.
5. Follow the same procedure for the opposite side.

End Caps

The bus body end caps if damaged can be removed and replaced (Figure 36). The front cap and rear cap (End Caps) follow the same general procedure in the removal process.

1. Due to the proximity and nature of the end cap removal, the drivers windshield assembly must be removed. Follow the procedure as outlined in the windshield removal section of this manual.
2. Front cap requires removal of the outside rear view mirror. Depending on the type mirror, the drivers side rear view mirror may not require removal.
3. Loosen and remove the passenger side rear view mirror support brackets. Remove the rear view mirror assembly. If the mirror is equipped with optional heater accessories, disconnect the heater harness connection.
4. Loosen and remove the front or end cap warning lights and disconnect all electrical connections between the cap and the body.

5. Remove as many rivets from the front end drip rail as needed to free the front cap for removal.
6. Remove all remaining rivets that attach the cap to the body.
7. Follow the same general procedure for the rear end cap removal. The bus rear windows and emergency exit door need not be removed to remove the end cap.

Optional Warning Lights

Warning lights other than standard may be mandated in some municipalities. The most common optional warning light (Fig. 34) is the roof mounted clear strobe light. Another common optional warning light is the cowl mounted amber directional light (Fig. 35, Item 1).

1. To replace the flash element in the strobe warning light, locate and loosen the dome mounting screws.
2. Lift and remove the dome assembly.
3. Locate the strobe bulb element and remove.
4. If the entire light assembly is to be removed follow the same procedures in steps 1, 2, and 3.
5. Locate the strobe light mounting screws attaching the light housing to the bus structure. Loosen and remove the mounting screws.
6. Lift the light assembly up, disconnect the harness connection, remove the gasket or seal between the light and the roof surface.

Body Attachment

The bus body tie downs vary in type and location in the bus structure. Each type of tie down application has an individual function in securing the overall bus substructure

“J” Bolts

The “J” clip and bolt encapsulate the chassis lower frame rail flange and floor structure. The “J” bolt mountings should be checked periodically to ensure the proper alignment and condition.

1. Locate the lock nut and washer located at the top of the “J” clip and bolt.
 - a. Loosen the “J” clip bolt lock nut at the floor structure flange and remove.

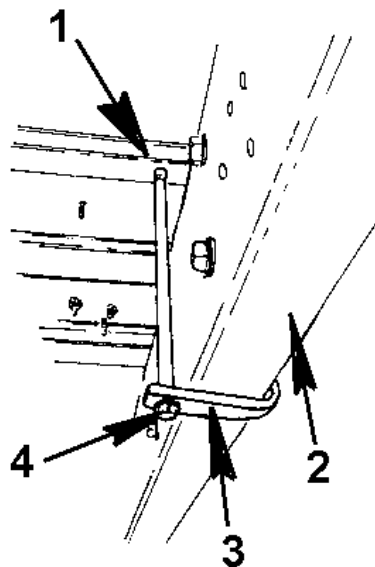

Figure 127 “J” Clip Removal

1. FLOOR STRUCTURE ASSEMBLY
2. CHASSIS FRAME RAIL
3. “J” CLIP
4. “J” CLIP MOUNTING ROD, NUTS AND WASHERS

- b. Slide the “J” clip bolt out of the floor panel flange.
- c. Check for the anti-squeak pad.

Shear Bolt Tie-Down

2. Shear bolt tie down is located at the rear section of the bus body. If the body has shifted more than is allowable the shear bolt will shear. **If the shear bolt has sheared, the bus body has moved; check all remaining body tie-downs. Report the condition to the bus fleet manager.**
 - a. The shear bolt would not necessarily be changed other than in the case of body shifting on the chassis.

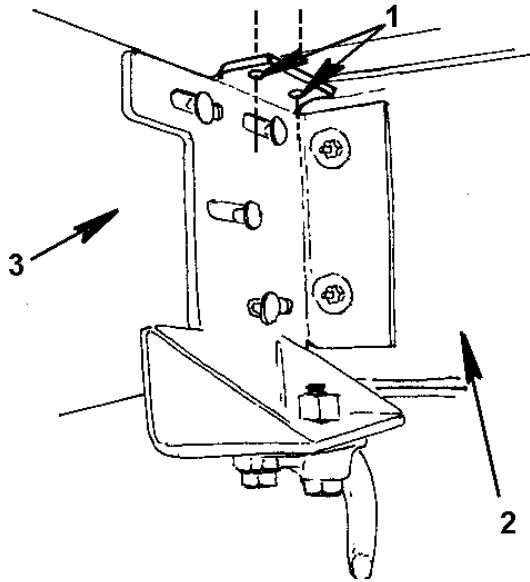

Figure 128 Shear Bolt Removal

1. SHEAR BOLT MOUNTING HOLES
2. REAR BUMPER ASSEMBLY
3. CHASSIS FRAME RAIL

- b. Periodically, the shear bolts should be checked for tightness.
- c. If the bolts have to be tightened they should be torqued. (See the torque chart for the required torque values)

Formed Tie-Down

3. The formed tie downs are the main structural body tie downs. The formed tie downs are located at the flange sections of the bus floor assembly and are secured at the inside of the upper flange of the frame rail. These tie downs should be checked for any possible movement, also checking for the anti-squeak pads. If the squeak pads are missing, the formed tie down clip may not be sufficiently retaining the floor section in place.

To remove formed tie down clip:

- a. Locate the lock nut on formed tie down clip at the floor assembly lower flange.
- b. Loosen the lock nut and remove the bolt.

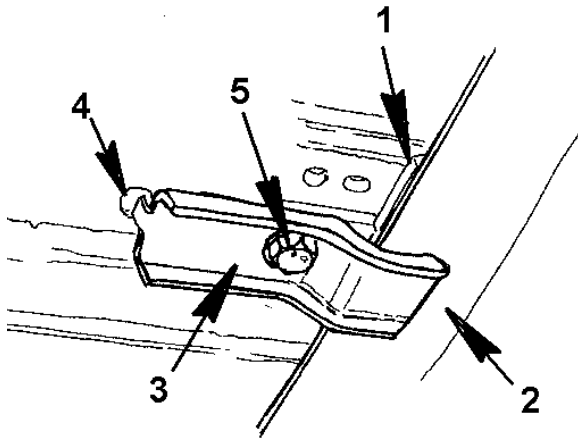

Figure 129 Formed Tie-Down Assembly Removal

1. CHASSIS SQUEAK PAD
2. CHASSIS FRAME RAIL
3. FORMED BODY TIE DOWN BRACKET
4. TIE DOWN LOCATOR HOLE
5. TIE DOWN MOUNTING BOLT

c. Remove the formed tie down clip.

Outrigger Tie-Down

The outrigger tie down assembly are located behind the cowl assembly. The driver side outrigger is mounted at the driver platform sub-structure.

4. The outrigger tie-downs are located at the outer flange on the body outrigger assemblies. The outrigger assemblies are bolted to the chassis frame rail. They are a spring mounted type assembly with bolt and lock nut.
 - a. Locate the outrigger end and tie-down hardware.

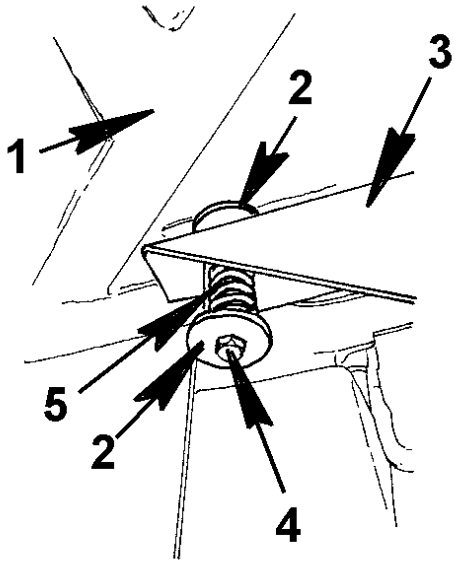

Figure 130 Out Rigger Tension Bolt Assembly Remove

1. DRIVER PLATFORM "K" BRACE ASSEMBLY
 2. TIE DOWN WASHERS (NUT NOT SHOWN AT TOP)
 3. CHASSIS OUTRIGGER BRACKET
 4. OUTRIGGER TIE DOWN MOUNTING BOLT
 5. MOUNTING BOLT TENSION SPRING
- b. Loosen and remove the lock nut and washer from the spring assembly.
- c. Remove the tie-down mounting bolt and spring assembly.
5. To remove the outrigger assembly:
- a. Locate the outrigger mounting bolts attaching the outrigger to the chassis frame rail.

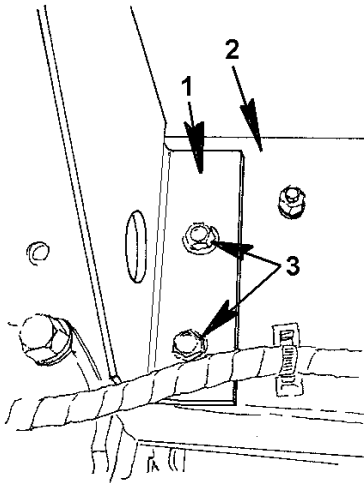

Figure 131 Body Outrigger Assembly Remove

1. OUTRIGGER FRAME BRACKET
2. CHASSIS FRAME RAIL
3. OUTRIGGER ASSEMBLY MOUNTING BOLTS AND NUTS

b. Loosen and remove the outrigger mounting bolts nuts and washers.

Static Roof Vents

The CE 200 and CE 300 are equipped with static roof vents located along the upper center of the bus roof line.

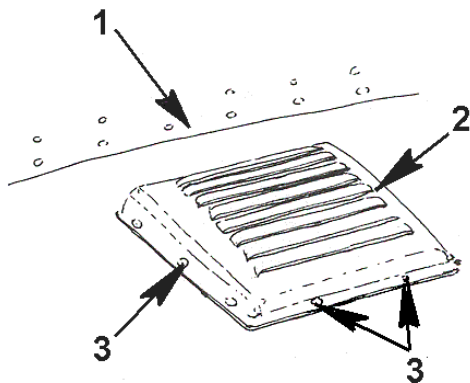

Figure 132 Static Roof Vent

1. BUS ROOF PANEL OVERLAP
2. STATIC ROOF VENT ASSEMBLY
3. STATIC ROOF VENT MOUNTING RIVETS

To remove the static air vent, if damaged:

1. Center punch all rivets in preparation for removal.

2. Use an 1/4" diameter replacement rivet of suitable length. Use a rivet gun of industrial quality to properly set rivets.
3. Use a 17/64" diameter drill bit and a heavy duty reversible drill.
4. Drill through rivet head until rivet sleeve separates from the rivet head.
5. Remove the static vent.
6. Clean the area around the vent of sealant or gasket material.

Mud Guards

The mud guards at the rear of the bus body are an available option. The optional mud guards located at the front wheel fender extension are covered in the Front End Manual (see S09009).

To remove the rear mud guards:

1. Locate the mounting bolts and reinforcing bar at the rear wheel well.
2. Loosen and remove the mounting nuts and bolts.
3. Remove the reinforcing bar.

3.2. INTERIOR BODY COMPONENTS — REMOVE

This section describes the interior bus body component removal procedures. The most common options are also described in this section.

Step Well Tread Plates

The step well assembly and step tread plates are removable. The step well tread plates should be checked for excessive wear and/or damage on a regular basis. If wear on the step tread is discovered, the section should be replaced immediately.

1. The step treads are secured utilizing mounting screws and an adhesive to secure the tread to the step well assembly.
2. Locate the six mounting screws in the step tread, loosen and remove the screws, and remove step tread panel.

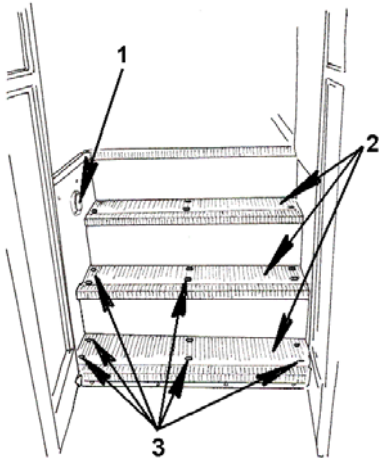

Figure 133 Step Well Tread Plates

1. STEP WELL ENTRY COURTESY LIGHT
2. STEP WELL TREAD COVERS
3. STEP WELL TREAD MOUNTING SCREWS

3. After removing the step tread, remove any adhesive and sealer along the outside surfaces of the area where the tread was removed.
4. To remove the tread panel at the entrance to the center isle and adjacent to the driver platform, locate the six mounting screws securing the edge trim piece at the joint between the center isle flooring and the entrance panel to be removed. Loosen and remove the trim strip mounting screws.
5. Locate the 4 driver seat mounting bolts and nuts securing the driver seat to the floor and entrance tread panel. Loosen and remove the mounting bolts with an assistant under the bus to remove the lock nuts.
6. Locate and remove the engine cover mounting bolts along the rear edge of the engine cover.
7. Remove the remaining 2 mounting screws from edge trim at the engine cover to the step well.
8. Remove the seal along the edge of the tread panel at the top step.
9. Remove the entrance panel step tread.
10. Remove and clean any adhesive on the floor panels used to secure the entrance tread panel.

Step Well Assembly-Removal

The entire step well assembly is removable in case of damage. To remove use the following procedure:

1. Remove the passenger entry doors. Refer to the Exterior Component Remove section of this service manual.
2. Remove the step tread plates.

3. Remove the assist handrail assemblies and trim panels at the top corners of the step well compartment.
4. Remove the step well courtesy light and disconnect electrical connections in the step well area.
5. Remove or pull back the flooring material around the entry area.
6. Remove the crash barrier panel at the entrance way if required.
7. Locate the spot welded sections of the step well assembly attaching it to the bus floor assembly. Carefully grind the welds and remove the step well assembly.
8. Inspect the entry door lower cross bar for damage, including the mounting points for the entry door. Replace as needed.

Assist Handrails

The assist handrails are located in the step well area and are mounted on the front seat crash barrier assembly. Handrails are also available as options and are mounted in the step well on the step well heater assembly (if equipped), or on the front plate assembly mounted to the right hand dash panel cover and attached to the bus cross beam assembly.

To remove the standard entry assist rail:

1. Locate the hex head mounting screw at the crash barrier panel hand rail attachment.

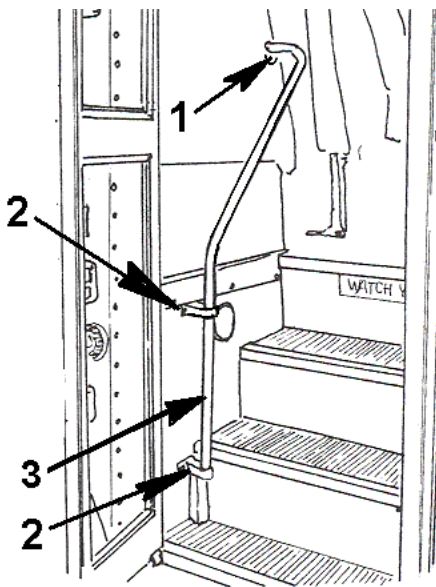

Figure 134 Assist Handrail Removal

1. ASSIST HANDRAIL CRASH BARRIER MOUNTING SCREW
2. STEP WELL ASSIST HANDRAIL MOUNTING BRACKETS
3. STEP WELL ASSIST HANDRAIL ASSEMBLY

2. Loosen and remove the hex head mounting screw.
3. Locate the mounting screws on the lower step well handrail mounting brackets, two on each bracket.

4. Loosen and remove the mounting screws, remove the assist handrail assembly.
5. To remove the stainless steel handrail from the lower mounting brackets, locate the set screw on the handrail assist mounting bracket.
6. Loosen the set screw and remove the handrail.
7. If the bus is equipped with the optional assist handrail, follow the same basic procedure as outlined in steps 3 through 7.
8. The top mounting bracket for the forward mounted handrail will be attached with a mounting screw attachment to the forward dash vertical support bracket or the step well optional heater side cover plate.
9. Loosen and remove the mounting screw and remove the forward assist handrail (if applicable).

Defroster Fans (Optional)

The defroster fans are optional equipment and when specified are mounted on the front header assembly. More than one fan may be specified. The fans are adjustable horizontally and vertically. To remove the defroster fan:

1. Locate the 3 mounting base screws (Fig. 87, Item 1), loosen and remove.
2. Disconnect the fan harness plug. Remove the defroster fan.

Sun Visor

IMPORTANT – All mounting and assembly hardware should be inspected every 30 days. Each driver should inspect the rear view glass surface on a regular basis for glass fractures and breakage. It is not uncommon for glass to fracture under high stress conditions when mounting hardware has not been maintained. When glass fractures occur, the glass should be replaced immediately.

The sun visor is mounted on a swing down bracket. The bracket assembly is attached to the header assembly above the driver's position. The assembly has two mounting screws attaching the bracket to the header assembly. The sun visor itself is attached to the brackets mounted to the header assembly. The sun visor swings upward and stores on the horizontal plane of the header assembly.

To remove the visor assembly:

1. Locate the bolts on each end of the visor assembly, loosen and remove. Remove the visor.

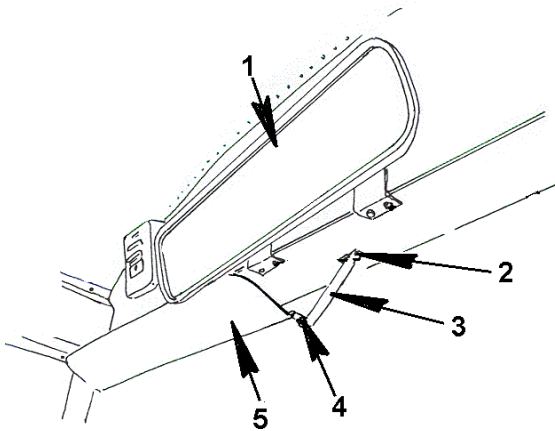

Figure 135 Sun Visor Assembly

1. DRIVERS INTERIOR REAR VIEW MIRROR
2. SUN VISOR HEADER MOUNTING BRACKET
3. SUN VISOR BRACKET ARM
4. SUN VISOR ADJUSTMENT ATTACHMENT BRACKET
5. SUN VISOR

2. To remove the entire assembly: locate the mounting bracket screws on the header assembly, two at each bracket.
3. Loosen the mounting screws each side and remove the entire sun visor assembly.

Destination Board Lights (Optional)

The destination sign or board option includes a translucent glass panel on the exterior of the front and rear end caps. The illumination for these panel are from lights on the inside of the end cap assembly. These lights are accessed through the lift up door on the header assembly directly behind the destination board.

1. Open the access door and locate the destination board bulbs and sockets.

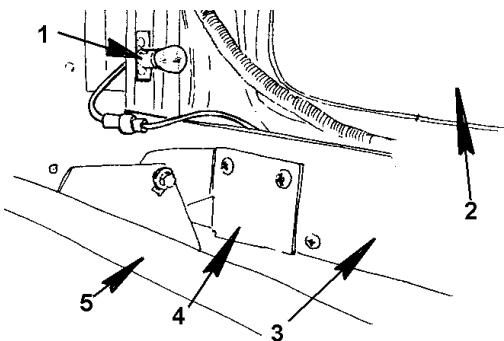

Figure 136 Lighted Destination Board Bulb Removal

2. Loosen and remove the bulb or bulbs.

Interior Rear View Mirror

The interior rear view mirror is located directly above the driver position. The mirror is mounted on two brackets attached to the windshield header assembly.

1. Locate the mounting screws on the mirror bracket assembly attaching the brackets to the header assembly. Loosen and remove the screws on each bracket.
2. Remove the mirror assembly.

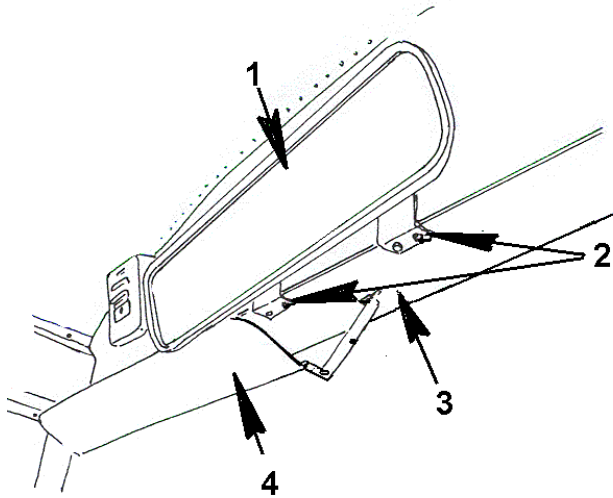

Figure 137 Drivers Interior Rear View Mirror

1. DRIVERS INTERIOR REAR VIEW MIRROR
2. REAR VIEW MIRROR MOUNTING BRACKETS
3. FRONT INTERIOR HEADER ASSEMBLY
4. SUN VISOR ASSEMBLY

3. To remove the mirror glass, remove the nuts and bolts on the mirror to release the adapter bracket.
4. Remove the adapter bracket, rubber strip and the metal backing plate.
5. Remove the mirror glass and discard (if mirror glass is broken or cracked).
6. The inside rear view mirror should be carefully inspected for small chips. If chips are found, do not install.

Dash Board Panels, Cluster and Switch Panels

The dash panel, switch panels and drivers storage panels are all constructed of injection molded composite material. All panels assemble together to make a clean fully functional assembly, enhancing visibility and ease of operation, with the ergonomically designed panels. All panels are removable for access to the components and assemblies in the driver control area (Figure 45). To remove the dash panels follow the procedures as listed.

1. Dash Panels

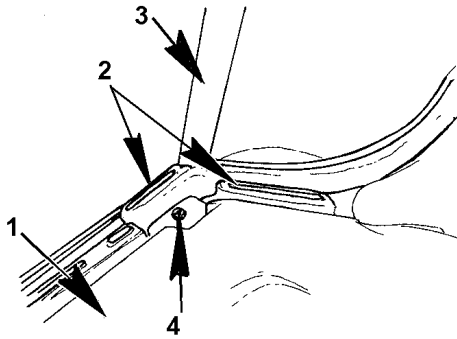

Figure 138 Passenger Side Entry— Dash Panel Section

1. PASSENGER SIDE ENTRY DASH COVER PANEL
2. DEFROSTER DUCT OPENINGS
3. WINDSHIELD VERTICAL PANEL SEAL
4. PASSENGER ENTRY PANEL COVER TOP PANEL MOUNTING SCREW

- a. Beginning at the passenger entry door and step well, locate the dash panel mounting bolts along the leading edge of the step well panel at the lower section of the windshield glass and seal.
 - b. Loosen and remove the panel mounting bolts.
 - c. Locate the panel lower edge mounting screws the secure the panel to the entry panel or step well heater panel (if equipped). Loosen and remove the mounting screws.
 - d. With the mounting screws and bolts removed, lift the step well panel cover upward and out.
2. Dash Panel / Cluster And Right Switch Panel
- a. Locate and remove the forward edge mounting bolts along the lower windshield seal. Loosen and remove the mounting bolts.
 - b. Slide the driver side window forward section open to access the mounting screw at the left hand corner of the dash panel assembly. Loosen and remove the mounting screw.
 - c. Locate the right wing switch panel, locate and remove any optional equipment mountings that may be mounted to the right wing switch panel; e.g., communication radio microphone (Figure 46).

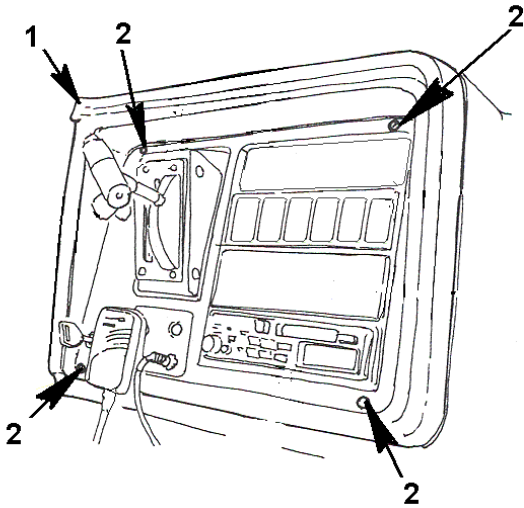

Figure 139 Right Wing Switch Panel Remove

1. DRIVERS RIGHT WING PANEL BEZEL TRIM RING
2. RIGHT WING PANEL BEZEL AND COVER MOUNTING SCREWS

- d. To remove right wing switch panel trim bezel, locate the four mounting screws (Fig. 46, Item 2) attaching the switch panel and bezel assembly. Loosen and remove.
- e. Remove the switch panel assembly and disconnect harness connections if necessary.
- f. Prior to removing the instrument cluster, the steering column cover must be removed. Locate the upper and lower column cover mounting screws.
- g. Loosen and remove the mounting screws and remove the steering column covers.

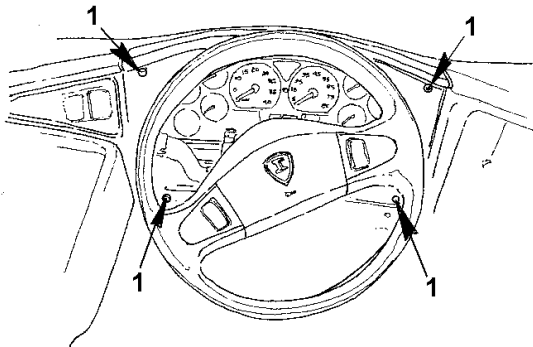

Figure 140 Cluster Attachment Mounting Screws

1. CLUSTER BEZEL MOUNTING SCREWS

- h. Locate the cluster bezel assembly and remove the bezel.
- i. Locate the cluster mounting screws, loosen and remove.
- j. Lift the instrument cluster out to access the harness connections. Disconnect the instrument cluster harness and remove cluster.

3. Left Hand Driver Switch Panel And Storage Bin

- a. The left hand switch panel contains the operating controls for many of the bus interior functions (Figure 48). The switch panel assembly must be removed first.

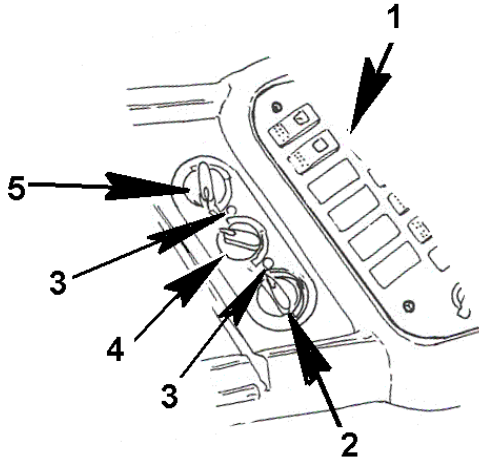

Figure 141 Heater Controls

1. LEFT WING SWITCH PANEL
 2. TEMPERATURE CONTROL KNOB
 3. ENVIRONMENTAL CONTROL PANEL MOUNTING SCREWS
 4. HEAT DIRECTIONAL CONTROL KNOB
 5. FRESH AIR / RECIRCULATION CONTROL KNOB
- b. Locate the heater, defroster, and recirculation control switches to the rear of the left hand switch panel. Remove the control knobs for the heater controls.
- c. Locate the six left hand switch panel mounting screws.

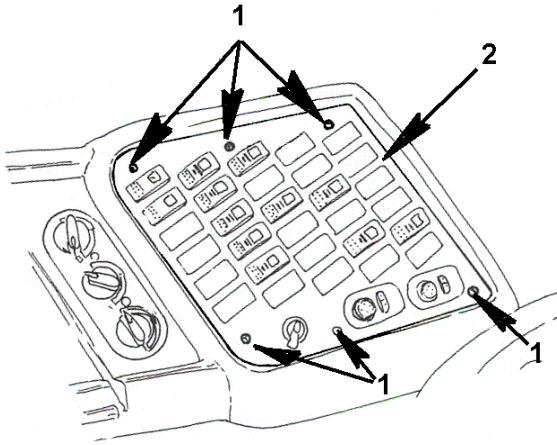

Figure 142 Heat Control and Left Switch Panel Assembly

1. DRIVERS LEFT WING SWITCH PANEL MOUNTING SCREWS
2. DRIVERS LEFT WING SWITCH PANEL

- d. Loosen and remove the panel screws.
- e. Lift the switch panel out and disconnect necessary harnesses for removal of the switch panel.
- f. Open the driver side storage compartment bin cover. Locate the mounting screws in the bottom of the storage bin. Loosen and remove the mounting screws.

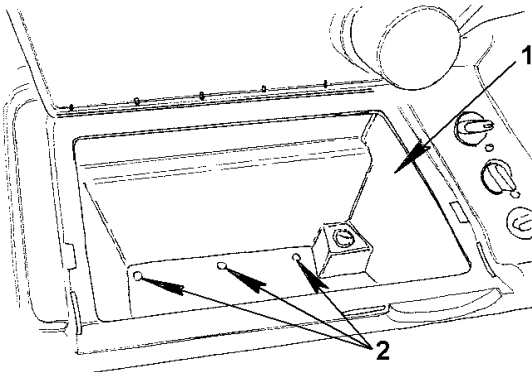

Figure 143 Drivers Storage Bin

1. DRIVERS LEFT PANEL STORAGE BIN
2. LEFT WING PANEL STORAGE BIN MOUNTING SCREWS (THREE OF SIX SHOWN IN BOTTOM OF STORAGE BIN)

- g. Locate the lower edge mounting screws mounting the panel to the driver's heater assembly.
- h. Locate the heater / defroster control harness and disconnect.
- i. Lift and remove the left hand panel dash assembly and storage bin.
- j. Disconnect the 12 volt power receptacle harness from the storage bin receptacle (if applicable).

Driver Side Sliding Window Assembly

The driver side window is an extruded aluminum framed sliding window. An optional driver side storm window is also available. The driver side sliding window assembly is secured in place with 9 mounting screws. To remove the standard driver window assembly:

1. Slide the forward section of the driver side window to the rear. Locate the two frame mounting screws on the forward vertical extrusion. Loosen and remove the fasteners.
2. Locate the two mounting screws on the bottom extrusion of the forward window section. Loosen and remove the mounting screws.

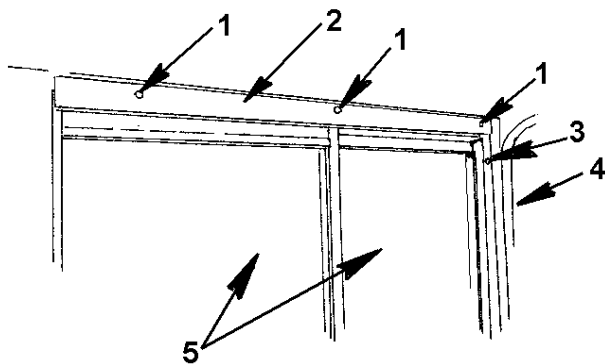

Figure 144 Drivers Upper Window Frame Mounting Screws

1. UPPER WINDOW FRAME MOUNTING SCREWS
2. DRIVERS WINDOW UPPER HORIZONTAL WINDOW FRAME
3. DRIVERS WINDOW VERTICAL FRAME MOUNTING SCREW
4. DRIVERS WINDOW FORWARD VERTICAL FRAME
5. DRIVER SLIDING WINDOW ASSEMBLY

3. Slide both window sections forward.
4. Locate the remaining two lower extrusion mounting screws at the rear bottom frame section. Loosen and remove the mounting screws.
5. Locate the two screws fastening the rear vertical extrusion to the bus structure, loosen and remove.

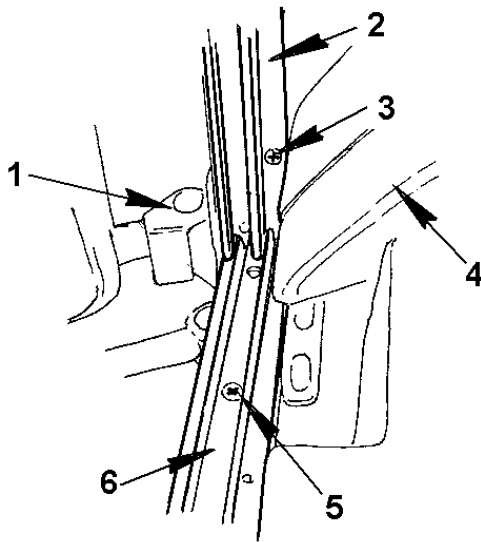

Figure 145 Lower Frame Mounting Screws

1. DRIVERS SIDE EXTERIOR REAR VIEW MIRROR ASSEMBLY
2. DRIVERS FORWARD "A" PILLAR
3. DRIVERS FORWARD VERTICAL WINDOW FRAME MOUNTING SCREW
4. DASH CLUSTER TRIM BEZEL
5. DRIVERS WINDOW LOWER FRAME MOUNTING SCREWS
6. DRIVERS WINDOW LOWER FRAME

6. Locate the TWO mounting screws along the lower window frame attaching the window to the window base frame.
7. Loosen and remove the mounting screws and remove the driver side sliding window assembly.

Driver Seat

The driver seat area has been designed for a high degree of driver comfort. Each component has been carefully located to reduce driver fatigue and to maximize driver operating ability and safety.

NOTE – The CE 200 / CE 300 bus may be equipped with an optional driver seat that may be different than the one described in this manual. If so, refer to the seat manufacturers manual for proper operation and maintenance.

The driver seat assembly has a mounting plate which is mounted to the driver side floor riser and secured with grade eight mounting bolts. The bolts are secured with lock nuts and washers and are torqued to specified values (Fig. 51, Item 5).

1. To remove the seat, an assistant is required. The assistant should locate the mounting nuts and washers on the underside of the driver riser.
2. With the assistant's aid, loosen and remove the driver seat mounting bolts and lock nuts.
3. Remove the seat.

Driver Seat Belts

The standard driver seat belt assembly is a three point lap and shoulder harness assembly, with retractor. The shoulder harness and the shoulder harness mounting assembly are attached to the structural pillar at the rear of the driver side sliding side window. The lap connection is mounted to the driver's floor riser assembly. The lap connector assembly is bolted through the floor utilizing grade eight structural bolts and lock nuts and washers.

! WARNING – The seat belt should be considered to have a limited life and must be replaced as needed throughout the life of the vehicle. The belts must be inspected for needed care and maintenance every 20,000 miles or more often if exposed to severe environmental or vocational conditions. All belts should be replaced at least every 5 years. Failure to maintain the seat belts could weaken the system, resulting in personal injury or death.

1. To replace the shoulder harness assembly, locate the shoulder harness mounting bolts on the driver side sliding window pillar. Remove the bolt cap covers.

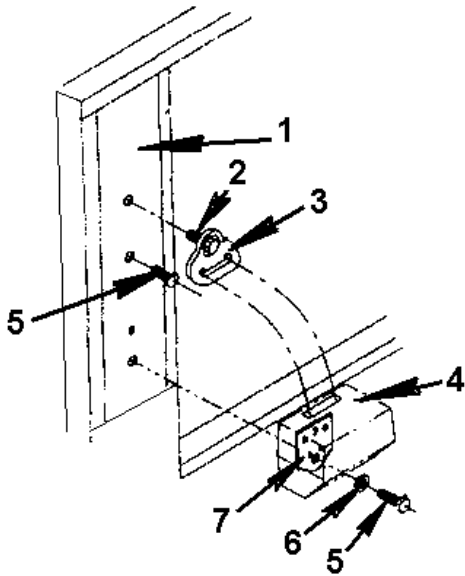

Figure 146 Drivers Shoulder Harness Mounting Bolts

1. DRIVERS WINDOW REAR PILLAR ASSEMBLY
2. SHOULDER HARNESS ATTACHMENT CLIP MOUNTING BOLT
3. SHOULDER HARNESS ATTACHMENT CLIP BRACKET
4. HARNESS AND LAP BELT PLASTIC COVER
5. MOUNTING BOLTS
6. LOCK WASHERS
7. LOWER SHOULDER HARNESS / LAP BELT MOUNTING BRACKET

2. Loosen the three mounting bolts and remove the shoulder harness assembly from the pillar at the rear of the driver side sliding window.

3. Locate the lower left hand lap belt connector, and mounting bolts on the left hand side of the driver seat cushion base.
4. To remove the lap clip assembly, locate the mounting bolt on the driver seat riser assembly. With an assistant securing the lock nut and washer from under the riser assembly, loosen and remove the lap clip assembly mounting bolt. (On suspension seats the right hand latch assembly is mounted to the seat.)
5. Remove the lap clip assembly.
6. Locate the floor mounted attaching point for the driver seat belt assembly.

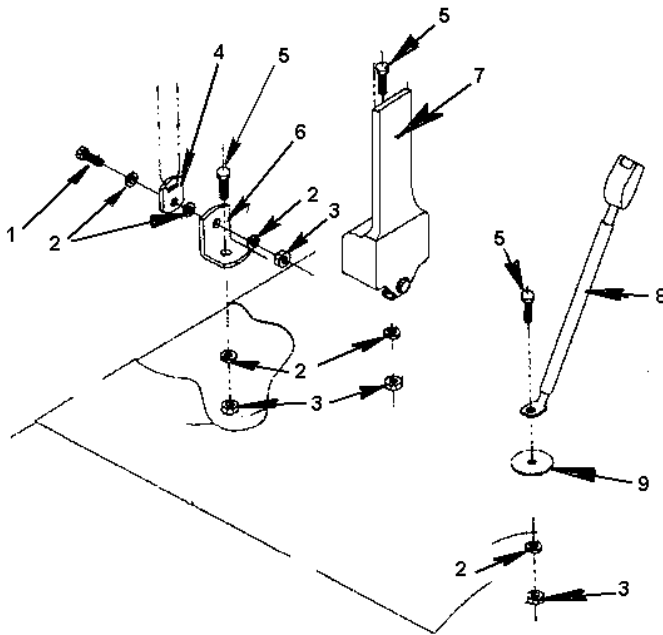

Figure 147 Drivers Seat Belt Floor Attachments

1. SEAT BELT ATTACHMENT BRACKET MOUNTING BOLT
2. SEAT BELT MOUNTING WASHERS
3. SEAT BELT ASSEMBLY MOUNTING NUTS
4. SEAT BELT ATTACHMENT BRACKET
5. SEAT BELT ASSEMBLY MOUNTING BOLTS
6. SEAT BELT ASSEMBLY FLOOR MOUNTING BRACKET
7. SEAT BELT MOUNTING ASSEMBLY PLASTIC COVER
8. DRIVERS SEAT BELT LAP LATCH ASSEMBLY
9. DRIVERS SEAT BELT LAP LATCH ASSEMBLY FLOOR MOUNTING WASHER

7. With the assistant below the floor, loosen and remove the seat belt floor attachment bolt.
8. Remove the seat belt attachment assembly.
9. When replacing the shoulder harness and lap belt assembly, replace both parts at the same time. Do not mix and match shoulder harness and lap assemblies as failure could occur if parts are mismatched.

Fire Extinguisher

The fire extinguisher is a recommended item on all buses (Fig. 44, Item 1). Placement of the extinguisher may vary depending on the specification requirements of the state or local municipality. The extinguisher should be checked monthly to ensure that it has sufficient charge. Look at the gauge located at the top of the extinguisher to verify proper charge.

1. The extinguisher mounting bracket is generally mounted on a vertical flat surface and attached with two screws. Some extinguishers are also equipped with a base plate and vertical mounting bracket.
2. Remove the extinguisher from the mounting bracket, locate, loosen and remove the mounting screws.

Driver Seat Bulkhead / Passenger Crash Barrier

The driver seat bulkhead or passenger crash barriers are located each side, forward of the first row of passenger seats. Additional barriers may be specified at the emergency exit doors or wheelchair access door (if specified). The barrier at the front curb side passenger seat may be equipped with an assist rail. To remove the barrier the assist rail would have to be removed first. The barrier structure is a chair rail mounted barrier unless otherwise specified. To remove the barrier:

1. Locate the mounting bolts on the inboard floor attachment. The bolts are secured through the floor assembly to the underside of the floor structure. An assistant may be required to loosen and remove the lock washer and nuts from the foot of the barrier assembly.
2. Locate the barrier mounting bracket along the chair rail on the bus wall.

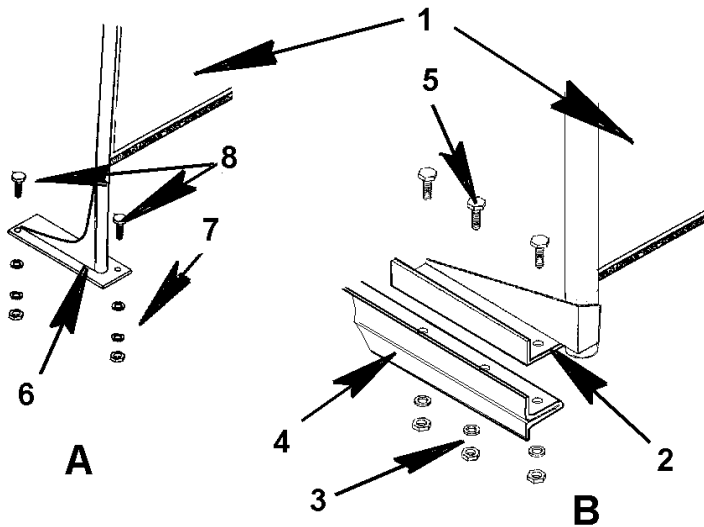

Figure 148 Crash barrier Mounting Bolts

A. CRASH BARRIER FLOOR MOUNTING ASSEMBLY (DRIVER SIDE CRASH BARRIER FLOOR MOUNTING SHOWN)

- 1. CRASH BARRIER PANEL ASSEMBLY
- 6. CRASH BARRIER FLOOR MOUNT PLATE
- 7. FLOOR MOUNT PLATE MOUNTING NUTS AND LOCK WASHERS
- 8. FLOOR MOUNTING PLATE MOUNTING BOLTS

B. CHAIR RAIL MOUNTING ASSEMBLY (PASSENGER SIDE CRASH BARRIER CHAIR RAIL MOUNT SHOWN FOR CLARITY)

- 1. CRASH BARRIER PANEL ASSEMBLY
- 2. CRASH BARRIER CHAIR RAIL MOUNTING BRACKET
- 3. CHAIR RAIL BARRIER BRACKET MOUNTING NUTS AND LOCK WASHERS
- 4. CHAIR RAIL SECTION
- 5. CHAIR RAIL SEAT MOUNTING BOLTS

- 3. Locate and loosen the three (3) mounting bolts, nuts and lock washers on the barrier mounting bracket.
- 4. Remove the crash barrier.
- 5. In some applications road triangles or other optional equipment may be mounted on the barrier directly behind the driver position. These items should be removed prior to removing the driver side crash barrier.

NOTE – Inspect and tighten all seat and barrier mounting hardware attachments. This should be performed at 30 to 45 day intervals. The seat leg bolts require 19–20 lbf-ft of torque.

Passenger Door Control Panel— Electric

The electric passenger door opener is standard on all CE 200 and CE 300 buses. Optional air operated and manual openers are also available. Prior to doing any work on the electric door mechanism disconnect the power supply, and set the manual override switch to emergency position.

Electric Door Opener

1. The electric door opener drive mechanism is located in the compartment directly over the passenger entry door.
 - a. To access the mechanism, rotate the door latch locking device and lift the door up.
 - b. Disconnect the power to the drive mechanism, locate the harness plug at the forward section of the door mechanism compartment. Disconnect the harness plug.

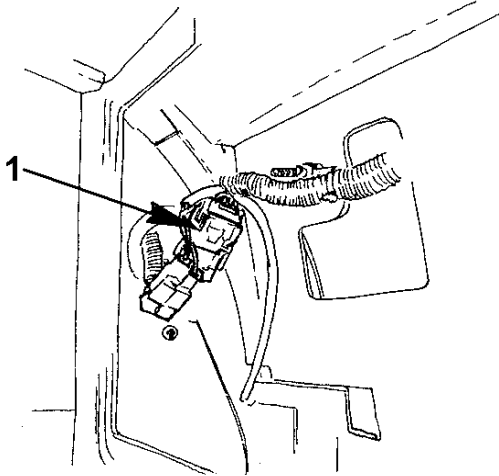

Figure 149 Electric Door Opener Harness Disconnect

1. ELECTRIC PASSENGER DOOR OPENER HARNESS CONNECTOR
2. To remove the door hardware from the drive mechanism:
 - a. Locate the drive arm mounting lock nut on the main gear drive plate.

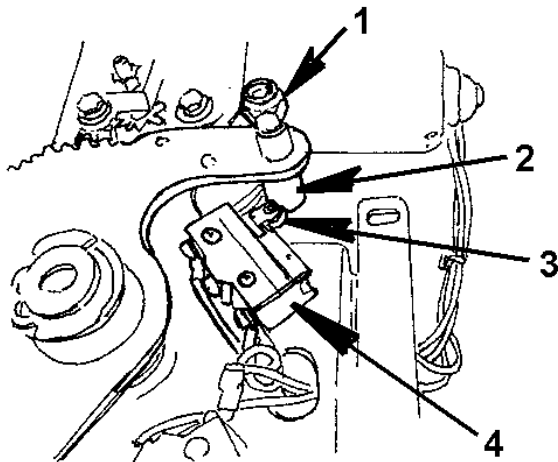

Figure 150 Drive Arm Disconnect

1. DRIVE ARM ATTACHMENT STUD AND NUT
2. DRIVE ARM LIMIT SWITCH POST
3. DOOR LIMIT SWITCH ACTIVATOR
4. DOOR LIMIT SWITCH

- b. Loosen and remove the lock nut from the drive arm assembly and main gear drive plate.
 - c. Remove the drive arm assembly end.
3. To remove the entire electric drive mechanism:
- a. Locate the six mounting bolts on the motor drive assembly.

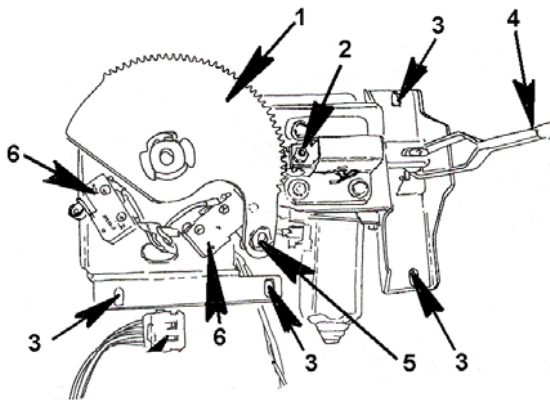

Figure 151 Door Opener Electric Drive Motor Remove

1. ELECTRIC DOOR OPENER DRIVE PLATE
2. ELECTRIC DOOR OPENER DRIVE GEAR ASSEMBLY
3. ELECTRIC DOOR OPENER ASSEMBLY MOUNTING BOLT HOLES
4. ELECTRIC DOOR MANUAL / AUTOMATIC ACTUATION SWITCH
5. DRIVE ARM ATTACHMENT MOUNTING STUD AND NUT
6. ELECTRIC DOOR OPENER LIMIT SWITCHES

- b. Loosen and remove the mounting bolts, and lift the drive motor out of the compartment.
4. To remove door opener connecting rods:
 - a. The main drive arm from the electric door drive mechanism is attached to the door bracket assembly. Main drive arm is a swivel joint attachment connection with lock nut and washer at the door drive mounting bracket. The door drive mounting bracket is located at the top of the forward door panel, and is mounted with two mounting bolts into the door assembly.
 - b. The rear door assembly of the passenger entry doors is connected utilizing a drive arm with swivel joints connected to the forward door bracket. The rear door drive arm is connected to a bracket mounted on the upper frame of the rear door panel of the main passenger entry doors. This bracket is mounted to the door frame assembly with two mounting bolts.
 - c. The door opener drive rods have swivel joints at each end and are secured to the brackets with lock nuts and washers at each end.
 - d. The doors are equipped with a mounting bracket with mounting points for the drive arm ends and swivels.

Passenger Door Removal

Removal of doors without removing drive arms:

1. To remove the individual doors, disconnect the door opener drive rod brackets at the door to be removed.
2. Locate and remove the two mounting bolts on the drive rod door bracket located at the top of the door assembly, remove the door mounting bracket.

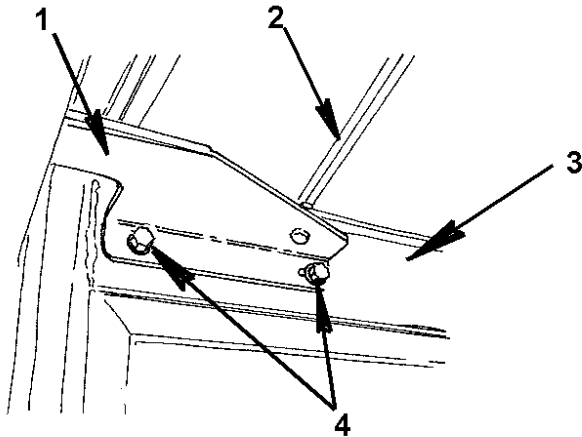

Figure 152 Drive Rod Door Bracket

1. PASSENGER ENTRY DOOR OPENER— DOOR BRACKET
2. PASSENGER ENTRY SECONDARY DOOR DRIVE ARM
3. PASSENGER ENTRY DOOR- FORWARD DOOR FRAME
4. DOOR DRIVE BRACKET MOUNTING SCREWS

3. With an assistant holding the door, lift the door up and out of the pivot block assembly.

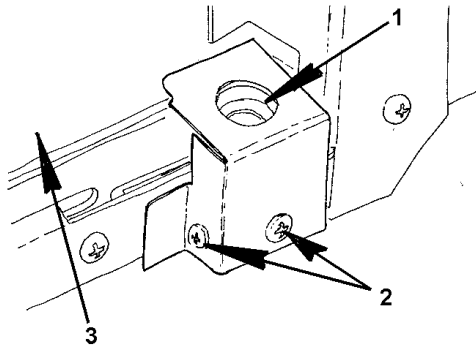

Figure 153 Passenger Door Pivot Block Remove

1. DOOR PIVOT ROD INSERT HOLE
2. PIVOT BLOCK COVER MOUNTING SCREWS
3. PASSENGER ENTRY STEP

4. Follow the same procedure to remove opposite passenger entry door.

Air Operated Door Opener (Optional)

The four major parts that make up the air door are the regulator, cylinder, door switch and the air valve. The actuator switch is located on the steering wheel, or may be located on the drivers console located to the right of the steering wheel. Various state regulations may apply.

The air door dump valve switch is located to the right of the drivers right wing switch panel and is accessible from the seated position. The air will empty out of the air cylinder when the ignition is turned "OFF" or when the dump valve is switched to "MANUAL". The dump valve switch is a toggle switch. Various state regulations may apply. (See Interior Install Section in this manual for adjustments)

The door removal procedure for the air operated door is the same as the electric door removal procedure. Follow the same procedures as outlined in steps 1 through 4.

Bus Interior Light Bars

The bus interior light bars run the entire length of the bus body on each side. The light bars encapsulate the bus harnesses, interior lights and speakers (if applicable). The light bar sections have cover plates at the end of each section. To remove the light bars:

1. Locate the joint covers between the section to be removed. Loosen and remove the mounting screws, then remove the joint covers.
2. Locate the mounting screws along the section of light bar to be serviced. Loosen and remove the mounting screws, then remove the light bar.

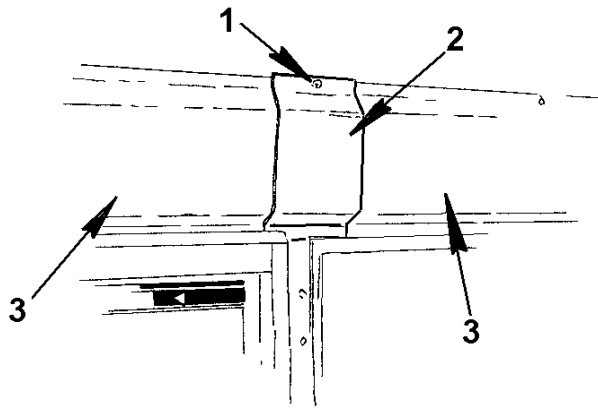

Figure 154 Light Bar and Joint Connectors Plates

1. LIGHT BAR JUNCTION COVER MOUNTING SCREW
2. LIGHT BAR JUNCTION COVER PLATE
3. LIGHT BAR ASSEMBLY COVERS

3. If a light or speaker assembly is located in the section of light bar removed, loosen the mounting screws attaching the light or speaker to the light bar.
4. Disconnect the harness connector for the speaker or light as may be required.

NOTE – The removal of the front and rear covers of the light bar allow access to the harness connectors at the interior of the bus end caps.

Seats and Seating Removal

NOTE – Inspect and tighten all seat and barrier mounting hardware attachments. This should be performed at 30 to 45 day intervals. The seat leg bolts require 19–20 lbf-ft of torque.

The standard seat in the CE 200 or CE 300 school bus is a two legged / chair rail mount type seat in 30", 36" and 45" lengths. The chair assembly legs are mounted along the center isle section of the bus and attached to the floor structure with structural bolts, lock washers and nuts. The out board side of the seat assembly is mounted to the chair rail assembly which is an integral part of the bus side wall. To remove the standard chair rail mounted seats:

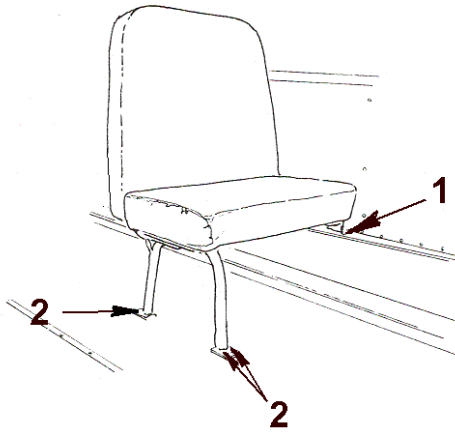

Figure 155 Standard Seat Mounting

1. SEAT CHAIR RAIL MOUNTING
2. STANDARD FLOOR MOUNTING PLATE AND ATTACHMENT BOLTS

1. With an assistant, locate the connecting bolts, washers and nuts at each individual leg. The nuts and washers are removed from the underside of the bus floor structure.
 - a. Loosen and remove the bolts, nuts, and washers attaching the seat legs to the floor assembly.

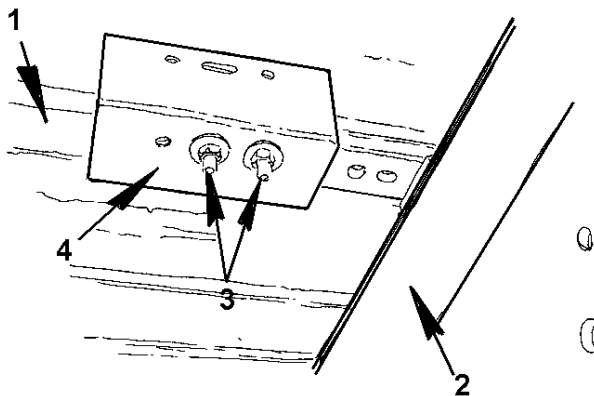

Figure 156 Seat Attachment Points

1. FLOOR STRUCTURE CHANNEL SECTION
2. CHASSIS FRAME RAIL
3. SEAT MOUNTING BOLTS, LOCK NUTS AND WASHERS
4. SEAT MOUNTING REINFORCING BRACKET ANGLE

- b. Tilt the seat bottom cushion forward by releasing the cushion latch clip. Tilt the seat bottom.
- c. Locate the mounting bolts and nuts along the chair rail of the seat to be removed.
- d. Loosen and remove the seat / chair rail mounting bolts, washers and nuts.
- e. Remove the seat.

2. Four leg seat removal.
 - a. Follow the same procedure as two leg mounting above with four leg mounting (no chair rail is involved).

Seat Cushion Removal

3. The bottom seat cushion is an easy to remove assembly. Care should be taken in the removal of the cushion.

CAUTION – Avoid leaning on the cushion when cushion is tilted. Damage or bending of the seat cushion hinge may occur.

- a. Tilt the bottom seat cushion forward and locate the hinge mounting screws on the bottom of the cushion.

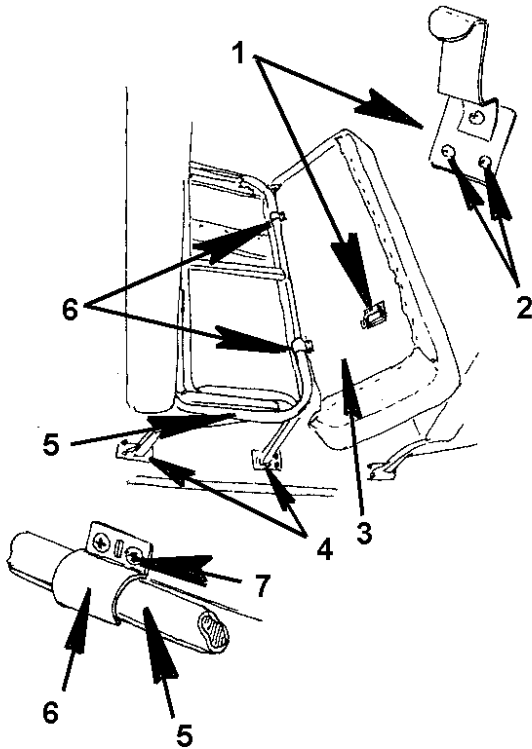

Figure 157 Seat Cushion Removal

1. SEAT ASSEMBLY TILT LOCKING LATCH
2. LOCKING LATCH MOUNTING SCREWS
3. SEAT CUSHION BOTTOM PLYWOOD BASE
4. SEAT FLOOR MOUNTING PLATE
5. SEAT FRAME TUBULAR STRUCTURE
6. SEAT CUSHION FRAME MOUNTING BRACKETS
7. SEAT CUSHION FRAME MOUNTING BRACKET SCREWS

- b. Loosen and remove the hinge mounting screws from both hinge assemblies.

- c. Remove the cushion assembly.
- d. Inspect the mounting hardware at the seat mount and seat clip.
- e. Inspect the seat back foam around the upper corner and in the knee impact area. If damage is discovered such as breakage or separated seals, the seat material should be replaced without delay.
- f. Inspect the staples that attach the seat tacking strip and inspect the upholstery for cuts, markings and other damage.

Small Child Restraint Seat (Optional)

4. The Small Child Restraint seat is an available option. (Fig. 60) The Small Child Restraint seats are generally located in the front section of the bus seating rows.
 - a. See the Small Child Restraint seat Owners Manual for operation and servicing of the seat assembly.

Flip— Up Emergency Exit Seat (Optional)

5. The flip up safety seat is an available option that is located at the side emergency exit doors (Fig 62).
 - a. The Flip up seat removal procedure follows the same procedure as the standard four leg seat mounting configuration. (Reference Step 2 of Seats and Seating Removal Section)

Seat Tracks (Optional)

Seat track assemblies are located along length of the floor and spaced to accommodate changes in seat requirements and spacing. The track option is available in two variations.

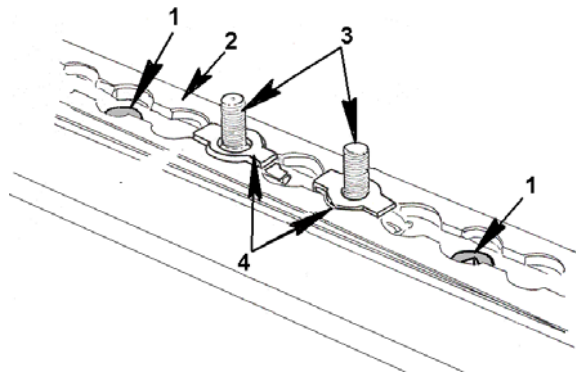

Figure 158 Seat Track Assembly

1. FLOOR TRACK TORQUE HEAD MOUNTING SCREWS
2. SEAT TRACK ASSEMBLY
3. SEAT TRACK SEATING ATTACHMENT STUDS
4. SEAT TRACK CHAIR MOUNTING INSERT LOCK CLIPS

1. Variation 1: The Seat track is secured through the plywood sub-floor and secured to the steel bus floor structure assembly.
 - a. The plywood is fastened to the floor with using an adhesive and mechanical fasteners.
 - b. The plywood sub floor is routed out to encapsulate the floor track. The floor track mounting is then drilled and screwed to the floor assembly.
 - c. The flooring material is then glued to the plywood flooring.

- d. To remove the seat track, locate the seat assembly and remove.
 - e. Locate the track mounting screws counter sunk in the track. Loosen and remove the screws, remove the track. If the plywood floor is also to be removed, follow the procedure in the floor repair section of this manual.
2. Variation 2: The seat track is mounted directly through the flooring material to the floor structure.
 - a. Remove the seats as required.
 - b. Locate the track mounting screws, loosen and remove the mounting screws.
 - c. Remove the seat tracks.

Seat Belts— Two Point (Optional)

When the Two Point Seat Belts option is required the seat track option is also required. (Fig. 61, Item 1).

1. The seat belt mounting is to the seat frame.

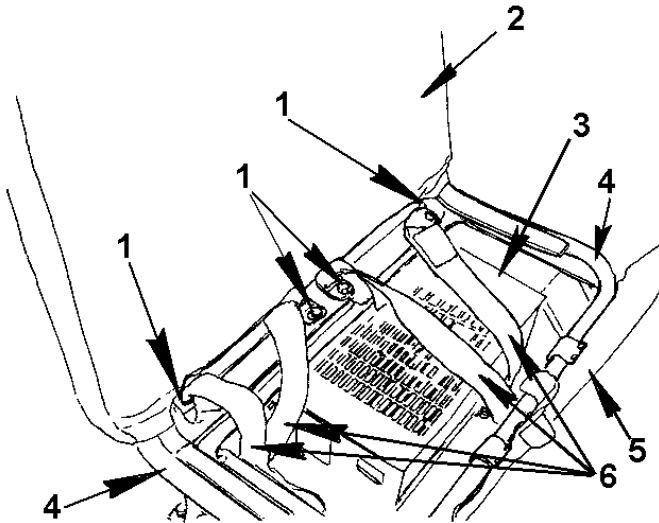

Figure 159 Two Point Seat Belt Seat Frame Mounting (30" SEAT SHOWN)

1. SEAT BELT MOUNTING CLIP, BOLTS AND LOCK NUTS
 2. SEAT BACK ASSEMBLY
 3. UNDER SEAT HEATER
 4. SEAT FRAME
 5. SEAT CUSHION BOTTOM (SHOWN TILTED FOR ACCESS)
 6. SEAT BELTS
- a. To remove the lap belt assemblies, disengage the securing clip.
 - b. Tilt the seat cushion forward, locate the seat belt mounting bolts and nuts on the seat frame.
 - c. Loosen and remove the lock nuts and washers, remove the mounting bolts.
 - d. Remove the seat belt assemblies.
 - e. Before re-installing the seat belt assemblies, check the belts for chafing and or wear.

2. The two point seat belt assemblies with handicap application use the seat track assemblies for fastening and securing the seat belts.
3. Locate the seat belt assembly to be removed, loosen and remove the floor mounted track stud bolt lock nut.
4. With the lock nut removed, lift the seat belt mounting end from the floor stud.
5. To remove the floor stud, slide stud forward and lift from track.

Passenger Windows

Passenger window assemblies are located each side of the bus and are removable without major disruption in the bus interior assemblies. Each window mounts in the window opening frame from the interior of the bus body. The windows are secured in place by a window post cover that encapsulates the windows within the body structure. To remove the side window assemblies use the following procedure.

1. Locate the four mounting screws on the cover plate on each side of the window assembly to be removed.

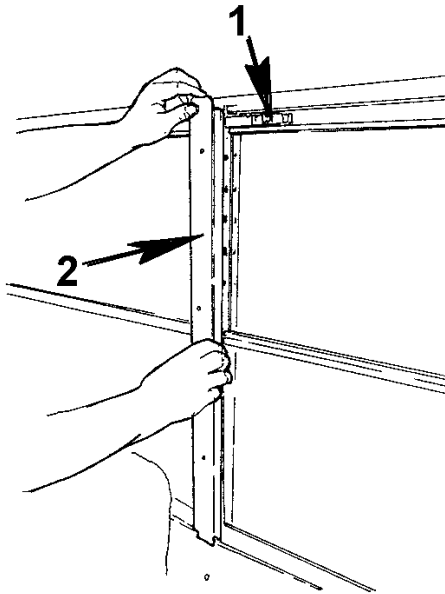

Figure 160 Passenger Window Cover Plate Mounting

1. WINDOW OPENER LATCH LOCK
2. PASSENGER WINDOW MOUNTING COVER PLATE

2. Loosen and remove the mounting screws. Use a Phillips head screwdriver, remove the window retaining cover plates.
3. Tilt the top of the window in and away from the bus light bar assembly.

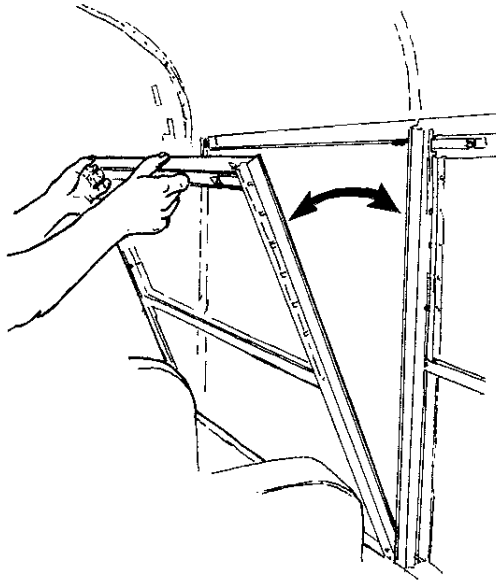

Figure 161 Passenger Window Removal

4. Lift the window assembly up and out of the window opening.

Emergency Window Exits

Emergency exit windows on the bus body consist of two different style assemblies, a horizontally hinged and a vertically hinged emergency exit window. Both sets of windows are installed from inside the bus and are secured by a mounting cover plate.

IMPORTANT – The push-out / kick-out windows are equipped with buzzer wires and the wires are routed from the window latch to the window header. Inspect the wire routing.

1. Horizontally Hinged Kick-out Windows and Vertically Hinged Kick-out Windows
 - a. Remove the four mounting screws securing the window mounting cover plates each side of the window assembly. (see Figure 160)
 - b. Tilt the top of the window in and away from the bus light bar assembly. (see Figure 161)
 - c. Lift the window assembly up and out of the window opening.
 - d. Locate the buzzer wire connection and disconnect.
 - e. Remove the caulking seal that may remain in the window opening.

Stationary Glass Removal

Stationary glass removal are those panels that are mounted in an "H" type seal in the emergency exit door, the wheel chair lift access door and the passenger side entry doors.

There are many variations of window and glass arrangements installed school bus applications. However, the installation and maintenance procedures given in this section can be used as general information that is contingent on state specifications (optional equipment).

If the glass is broken it may have already fallen or been removed from the rubber gasket or seal. It is often necessary to remove cracked or otherwise imperfect glass that is still intact. In this case, it is a good practice to criss-cross the glass with strips of masking tape before removal. This will help hold glass together and minimize the risk of injury.

Follow the procedure as listed below for glass removal.

1. Remove the lace rubber from the rubber gasket by prying out the edge of the lace rubber from the groove and continue to pull out the rubber.
2. For easy removal, insert a putty knife between the rubber gasket and the glass to break the sealant seal, making sure the glass is not stuck.
3. Repeat step two on the opposite side of glass.
4. Position an assistant outside the vehicle at the glass.
5. From inside the bus, push the glass from the rubber seal.
6. Have the assistant remove the glass and discard.
7. Remove the gasket from the window flange.
8. If the gasket is cut or damaged, discard and replace with new gasket.

Emergency Window Exit Alarms

Depending on which type, horizontal or vertical kick-out style window, the window exit alarms are removed by:

1. Remove the four mounting screws securing the window mounting cover plates each side of the window assembly.
2. Remove the window from the window opening, remove any caulking seal that may remain in the window opening.

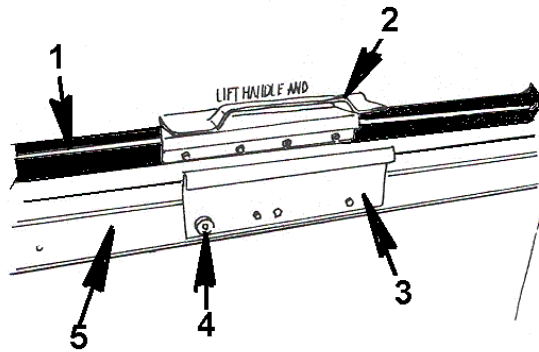

Figure 162 Emergency Window Alarm Switch

1. WINDOW SEAL
2. EMERGENCY WINDOW LATCH HANDLE
3. EMERGENCY WINDOW LOWER LOCK BRACKET
4. EMERGENCY WINDOW AJAR WARNING SWITCH
5. PASSENGER WINDOW LOWER FRAME

3. Remove both sets of screws at each end of the window frame at the bottom (or side if vertically hinged) that hold the plunger switch in place.
4. Remove the wire lead that is connected to the switch.

Emergency Exit Doors, Buzzers and Latches

The side and or rear emergency exit door should be inspected daily for proper operation, as stated by the instruction decal. The door buzzer / alarm should be checked with the ignition switch in the "ON" position. If the door buzzer sounds after the door has been closed, check the door switch adjustment and electrical installation to determine the cause of the problem. The door switch will require an adjustment in or out to eliminate the problem.

Inspect the door hold back device and the mounting hardware torque for distortion at regular intervals. All emergency exits should be inspected and operated per the operational labels on a daily basis.

Exit Door Hold-Open Device

1. To remove the exit door hold back device use the following procedure.
 - a. Open the exit door and locate the mounting screws on the device on the interior of the door frame.

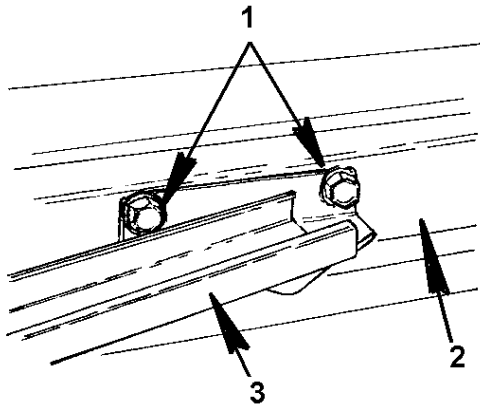

Figure 163 Exit Door Hold Open Device

1. EMERGENCY DOOR HOLD OPEN BRACKET MOUNTING SCREWS
2. EMERGENCY DOOR FRAME
3. EMERGENCY DOOR STAY ARM

- b. Loosen and remove the mounting screws.
- c. Follow the same procedure for the opposite end of the door hold open device.
- d. Remove the device.
- e. Prior to installation check the latching mechanism and lubricate as may be required.

Door Buzzer Assembly

Each side or rear exit door is equipped with a door open buzzer indicator. The buzzer assembly is operated by a plunger type switch (Fig. 164, Item 1) located at the door opening (Fig. 67, Item 4).

2. To remove the door buzzer assembly use the following procedure.
 - a. Locate the buzzer assembly mounting bolts.
 - b. Loosen and remove the buzzer assembly mounting screws.

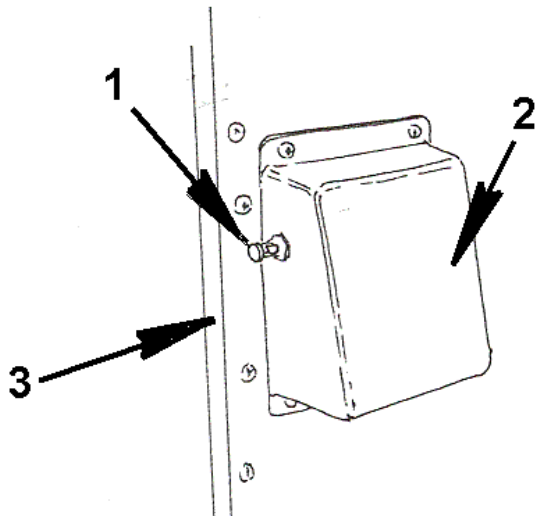

Figure 164 Door Buzzer Assembly

1. SWITCH ACTIVATION PLUNGER
2. DOOR AJAR WARNING BUZZER ASSEMBLY
3. EMERGENCY DOOR OR WHEEL CHAIR ACCESS DOOR OPENING FRAME

- c. Remove the buzzer assembly, disconnect the wire harness plugs.
- d. To remove the buzzer cover from the assembly loosen the plunger assembly mounting nut, remove plunger and cover.

Door Latch Mechanism

The emergency exit doors are equipped with an inside and outside latch handle mechanism. To remove the mechanism use the following procedure.

3. From inside the bus, locate the lift type lever to open the latch mechanism.
 - a. With the door in the open position loosen and remove the four mounting bolts securing the latch assembly to the door.

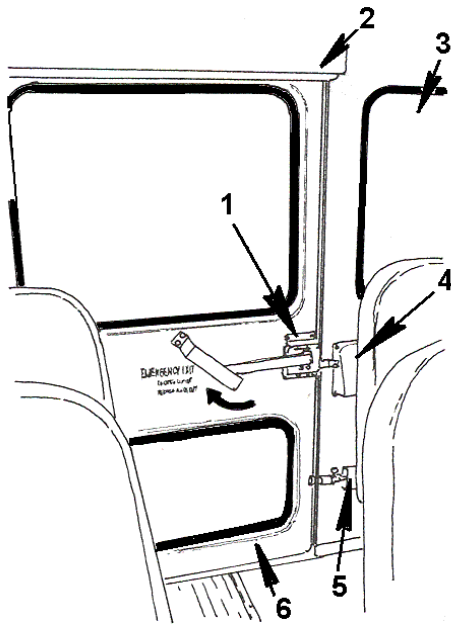

Figure 165 Door Latch Assembly (Rear Emergency Exit Door Shown)

1. DOOR LATCH MECHANISM
2. HEAD BUMPER
3. REAR BUS WINDOW
4. DOOR AJAR ALARM MECHANISM
5. DOOR SWITCH STARTER INTERLOCK (IF APPLICABLE)
6. REAR EMERGENCY DOOR ASSEMBLY

- b. To remove the exterior handle, locate the torque head screw in the top of the handle and one in the side of the handle.
- c. Loosen and remove both torque head screws, remove the handle.
- d. To remove the handle mounting plate, locate the 2 Phillip head screws on the handle mounting plate, loosen and remove screws.
- e. Remove the handle assembly mounting plate.
- f. Prior to installation, check the door latch mechanism and lubricate.

Wheelchair Lift (Optional)

The wheelchair lift is an available option and can be located in various positions in the bus body. The wheelchair lift is supplied with a 180 degree swing open door, which allows for full door opening access. The operation and maintenance of the chair lift assembly is supplied with the manufacturer's manuals. The wheelchair lift assembly controls are integrated with the bus electrical system.

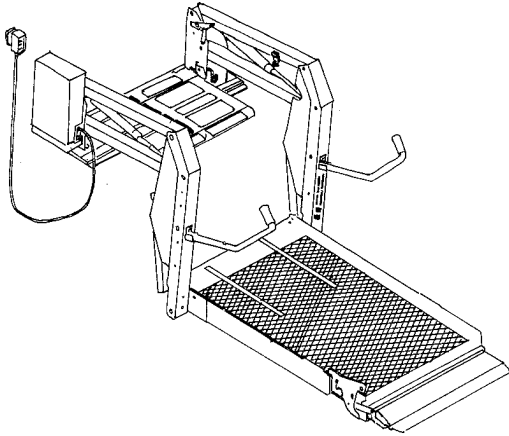

Figure 166 Wheel Chair Lift (Optional)

The chair lift door is equipped with an interlock with door ajar alarm system, notifying the driver of the door status.

1. For removal or service of the chair lift system, and or any adjustment, see the manufacturer's operator manual and maintenance guide for the proper operation and service for the chair lift assembly.

Wheelchair Floor Plates

The wheelchair floor plates are mounted directly to the bus floor assembly and are installed to secure the wheelchair during transport. Two mounting plates are required to secure each wheelchair. The wheelchair mounting plates are secured to the floor utilizing four (4) grade eight carriage bolts (Fig. 75, Item 1) with washers and lock nuts.

1. To remove the wheelchair mounting plates, locate and loosen and remove the lock nuts and washers from the underside of the bus floor assembly.
2. Push the mounting bolts upward through the floor.
3. From inside the bus area, remove the mounting bolts and wheel chair floor plates.

Wheelchair Seat Belts and Shoulder Harness

The wheelchair seat belts and shoulder harness assemblies are attached to the floor and wall harness track assemblies. When not in use the harness and seat belt assemblies may be stored in a shoulder harness storage bag (Fig. 74, Item 2).

1. To remove the shoulder harness assembly track, locate the track section (Fig. 73, Item 2) above the bus body light bar along the upper section of the body (if equipped).
2. Locate the torque head mounting screws (Fig. 73, Item 3), loosen and remove.
3. Remove the harness track assembly.

Rear Door Glass Protection Screen

The rear lower door window protection screen is an available option. This screen protects the lower rear door window from damage from items that may cause damage to the lower door glass. To remove the lower door window glass screen:

1. Locate the mounting screws (Fig. 66, Item 4) around the perimeter of the screen assembly and attachment clips, loosen and remove the screws and clips.
2. Remove the screen.

Safety Equipment — Required

Fire Extinguisher removal and check.

1. The fire extinguisher is generally mounted in the area around the driver position (Fig. 44, Item 1). Locate the extinguisher and mounting bracket.
2. Release the strap latch securing the extinguisher to the base mounting bracket.
3. Locate the bracket mounting screws, loosen and remove.
4. Remove the extinguisher mounting bracket.
5. With extinguisher bracket removed, secure the extinguisher in the bracket assembly and latch the locking strap. This is to prevent any damage to the extinguisher or the possibility of the extinguisher being discharged.

First Aid Kit

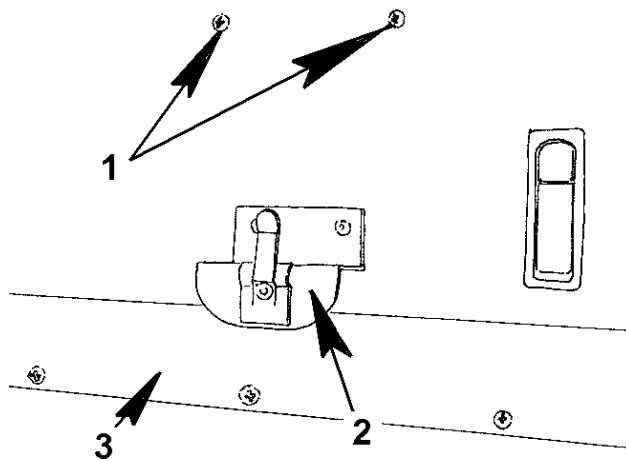

Figure 167 First Aid Kit Mounting Bracket

1. FIRST AID KIT UPPER MOUNTING SCREWS
2. FIRST AID KIT LOWER MOUNTING BRACKET
3. INTERIOR FRONT HEADER PANEL ASSEMBLY

6. The first aid kit is generally mounted on the front bulkhead over the windshield assembly (Fig. 85, Item 2). The first aid kit is secured in a mounting bracket to the bulkhead structure.

7. Release the lower clip on the mounting bracket, loosen and remove the first aid kit mounting screw at the top of the handle assembly.
8. Remove the first aid kit.

Safety Equipment — Optional

Body Fluid Clean-up Kit

1. The Body Fluid Clean-up Kit is also mounted on the bulkhead over the windshield assembly (Fig. 86, Item 2).
2. The Body Fluid Clean-up Kit is secured in a mounting bracket to the bulkhead structure.
3. Release the lower clip on the mounting bracket, loosen and remove the first aid kit mounting screw at the top of the handle assembly.
4. Remove the body fluid clean up kit.

Exterior Light Monitor

To remove the exterior light check monitor, locate the four mounting screws securing the monitor to the front bulkhead over the driver position (Fig. 69, Item 4).

1. Loosen and remove the four mounting screws.
2. Carefully remove the light check monitor.
3. Locate the connecting harness plugs from the monitor.
4. Disconnect the plugs and remove monitor.

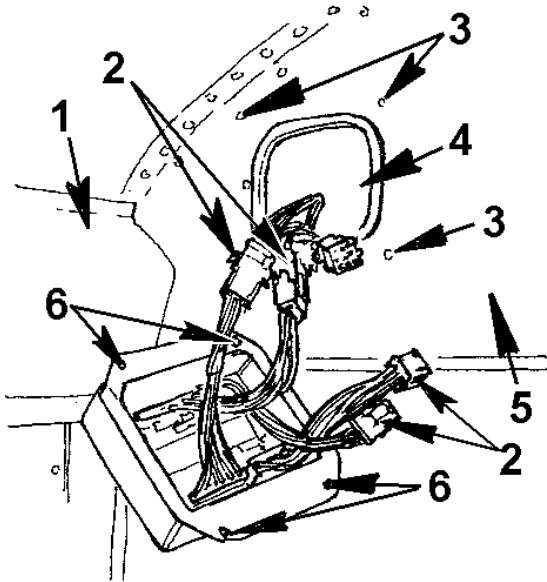

Figure 168 Exterior Light Monitor Harness Connections

1. DRIVER LIGHT BAR ASSEMBLY
2. EXTERNAL LIGHT MONITOR HARNESS CONNECTORS
3. EXTERNAL LIGHT MONITOR MOUNTING SCREW HOLES
4. EXTERNAL LIGHT MONITOR HEADER HARNESS ACCESS OPENING
5. DRIVERS OVERHEAD FRONT BULKHEAD
6. EXTERNAL LIGHT MONITOR SCREW ATTACHMENT MOUNTING HOLES

Fuel Sender Access Hatch

The fuel sender access hatch may be located in different positions depending on the location of the fuel tank. With rear mounted fuel tanks (between the frame rails) the fuel sender access hatch is located in the center aisle toward the rear of the bus. With side mounted fuel tanks, the fuel sender access hatch or opening is located above the tank generally on the right (curb) side of the bus body. Check the floor under the forward passenger seats for the access location.

1. To remove the access hatch under the passenger seat, it may require removing the seat assembly.
2. With the seat assembly removed (if applicable), locate, loosen and remove the fuel sender access cover mounting screws.

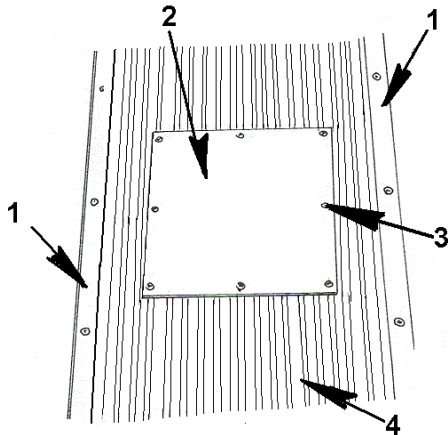

Figure 169 Fuel Sender Access Hatch

1. CENTER ISLE TRIM COVERS
2. FUEL SENDER ACCESS HATCH
3. FUEL SENDER COVER ACCESS HATCH MOUNTING SCREWS
4. CENTER ISLE FLOOR RUNNER

3. Follow step 2 for center isle, rear tank access cover removal.

Flooring

Flooring in the CE 200 and CE 300 bus should be inspected daily. This includes floor trim, mounting hardware that secures floor trim and the step tread. Mounting screws should be tightened if found loose. Regular cleaning and proper maintenance will prolong the life of the floor covering material. The floor should be mopped weekly with a mild detergent. If floor wear or damage is evident, the flooring should be repaired or replaced immediately.

Determine if floor surface material has a plywood sub-floor. To determine, inspect the side entry door area. Look for a slightly raised trim panel. If trim panel is present, the floor is equipped with plywood sub-flooring.

1. Seats do not have to be removed if replacing only center isle mat.
2. Remove fasteners that secure center isle mat trim.
3. Remove the damaged area.
4. Measure damage area to be repaired for correct sizing.

Plywood Sub-Flooring

1. If plywood sub-floor is present, check condition of plywood for damage.

If damage or wear to the floor covering is under the passenger seat areas, the seats must be removed to repair the area affected.

2. Remove the seats in the area to be repaired. Follow the procedure for seat removal as outlined in the Seat and Seating Removal section in this manual.
3. Remove the flooring material that has been damaged or worn.

4. Measure the new flooring for fit.
5. If the plywood sub-floor is damaged, measure the area and remove the existing plywood.
6. Fill and seal any holes in floor from previously mounted plywood, clean adhesives from floor and prepare surface for replacement plywood.

4. INSTALL

4.1. EXTERIOR BODY COMPONENTS

This section describes the procedures required to install the exterior body components that may have already been removed. All necessary warnings and safety precautions remain in effect during these installation procedures.

Windshield Wiper Install

Prior to installation of the windshield wiper assembly, check blades and washer fluid hoses for replacement.

1. Locate the windshield wiper drive stud and mark previously located to help set alignment of wiper arms.

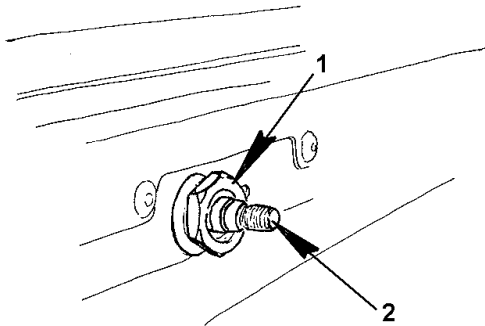

Figure 170 Windshield Wiper Drive Stud

1. WINDSHIELD WIPER DRIVE STUD MOUNTING JAM NUT
2. WINDSHIELD WIPER DRIVE STUD

2. Place windshield wiper arm on drive stud aligning the previously marked parts.
3. Install the mounting nut and hand tighten.
4. Follow the same procedure for the opposite side if both wiper arms have been removed.
5. From the drivers position, turn the ignition key, and turn on the wiper switch on. Allow at least one full cycle of wiper operation.
6. Turn the wiper switch to the off position and allow the wipers to go to the park position.
7. Turn the ignition key off. Go outside the bus and check the location of the wipers in the parked position.
8. Check dimensions as specified in Figure 171.

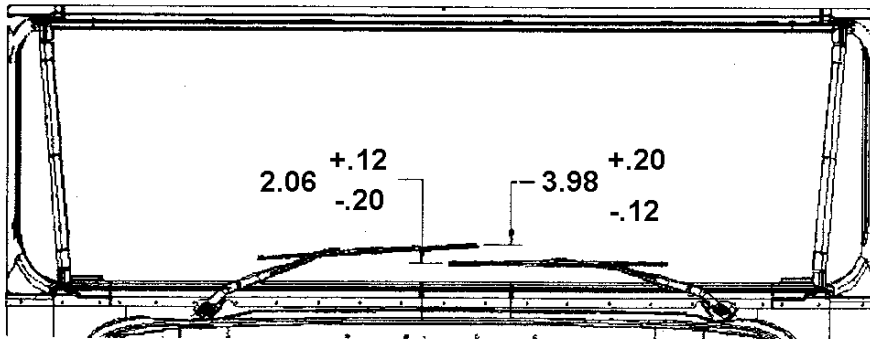

Figure 171 Windshield Wipe Alignment Dimensions

9. If the location is correct, tighten the wiper arm retaining nut to the proper torque value (See Torque chart).
10. If the wiper arm is not in correct position, remove retaining nut, reposition wiper arm, and check dimension.
11. Install wiper arm retaining nut and torque to correct value.
12. Replace plastic cap on wiper arm assembly covering retainer nut.
13. Reconnect windshield washer fluid supply hoses at cowl and windshield wiper arm.
14. Operate the windshield wipers and washer to verify correct operation. If wipers contact each other or the window frames during operation, or if they look close and might contact each other or the windshield frame, adjust the wiper arm orientation as needed.

Windshield Install

Prior to windshield installation, the windshield glass should be inspected for cracks and or chips. The windshield fence structure and locator tabs should be inspected for any type of bends or damage that might create problems in seal mounting and/or possible leaks. The windshield seal should also be checked for breaks, cracks or any other deformity that might cause windshield leaks or improper fit.



WARNING – Always wear safety glasses and gloves to prevent accidents from occurring. Extreme care should always be taken when handling glass and repair tools.

IMPORTANT – An assistant is required during the installation of the three piece windshield.

1. Prior to installing the 3 piece windshield:
 - a. Check the windshield mounting frame (fence) and mounting tabs for any bends or distortion in the assembly. Straighten if necessary.

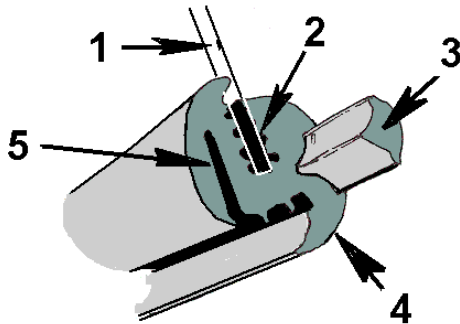

Figure 172 Windshield "S" Seal Cross Section

1. WINDSHIELD GLASS SECTION
2. GLASS SEAT OPENING
3. LOCK LACE
4. WINDSHIELD "S" SEAL ASSEMBLY CROSS SECTION
5. WINDSHIELD FENCE MOUNTING ORIFICE

- b. Check the windshield "S" seal for any cracks, breaks or deterioration. If found replace "S" seal. Check the windshield glass for cracks or chips in the glass or the edges. If the glass edge is chipped it should be ground smooth prior to installation.
- c. When handling glass avoid contacting the glass with anything that might chip or crack the edges of the glass. Pressure on the glass will tend to concentrate at the chipped areas, causing cracks. If the glass is cracked, do not install. Replace with a new section.

2.

Installation

For large applications such as the windshield center section, install the mounting seal on the windshield frame around the opening.

- a. Align the seal on the insert tabs and lower windshield mounting frame.

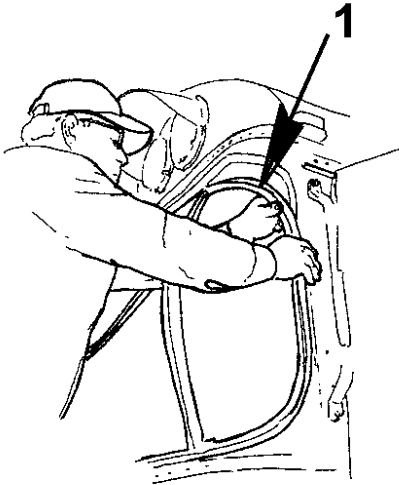

Figure 173 Install Windshield Seal

1. WINDSHIELD "S" SEAL INSTALLATION- WING PANEL

- b. Spray a foam type window cleaner or soapy water solution on the windshield seal. This will lubricate the seal and help in the installation of the windshield glass.
- c. With an assistant, locate the windshield glass panel section from the padded work stand and place in approximate position on the cowl assembly.
- d. With the technician and an assistant on the opposite side of the bus windshield area, place the glass in the lower section of the windshield seal. Using a flat stock windshield tool work the glass into the lower seal section.
- e. Align one side of the glass into the vertical seal section at the tee seal connector. Recheck the for alignment on the tab assembly.
- f. Using the flat stock tool, ensure the glass is in the position in the vertical section. Use the same tool on the inside of the windshield to properly seat the glass in the vertical section.

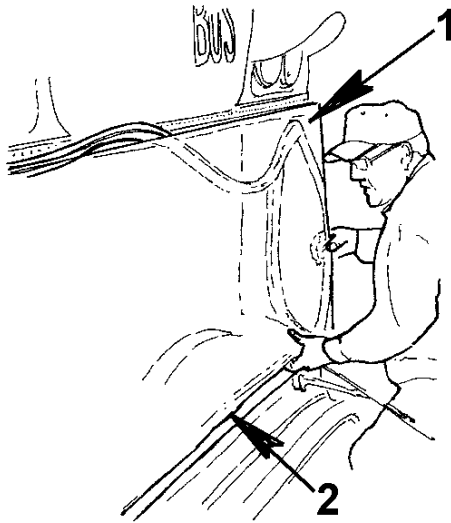

Figure 174 Seating Glass In Seal

1. WINDSHIELD CENTER PANEL
2. WINDSHIELD LOWER SEAL SECTION

- g. With the assistant on the outside of the windshield glass, steady the assembly, insert a 1/8" rope section in the glass seal around the upper section of the main glass panel. Spray the glass again with a soapy solution to help insert the glass into the upper seal.
- h. The assistant from the outside should apply a steady pressure against the upper portion of the center glass toward the windshield frame.
- i. The technician using the glass tool should encapsulate the top corner of the windshield glass on the fence (or frame), then with a constant, steady pulling motion on the rope work his way across the top of the interior of the windshield glass, checking the glass is seating in the seal as he pulls the rope. If the step is done properly the windshield should be mounted in the seal on the windshield frame around the top and bottom and both ends of the center panel.
- j. With the windshield glass properly seated in the top and bottom frame, use the flat stock tool and/or other appropriate glass tool as may be available to work the seal around the opposite end of the vertical windshield seal.

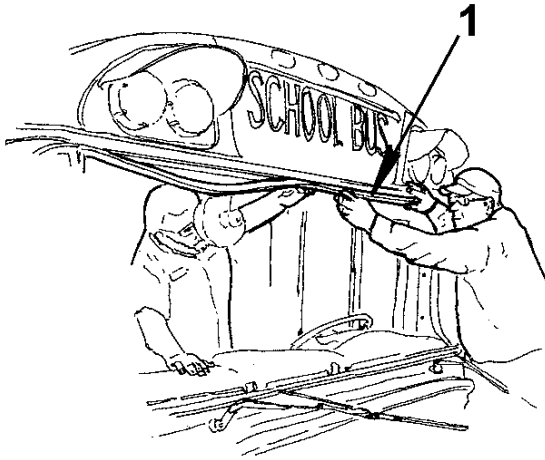

Figure 175 Windshield Installation

1. ALIGNING SEAL AND GLASS ON UPPER MOUNTING FENCE

- k. Check both the interior and exterior of the windshield panel for any irregularities in the seal that could cause a leaking condition.

- 3.

Side Panels / Wing Panels

Prior to installing side panel or wing glass, check the glass for cracks or chips.

- a. Align seal with windshield frame at wing panel area.
- b. Place the wing or side panel glass at the top corner of the seal and align the inboard edge in the vertical seal adjacent to the center windshield panel.
- c. Spray the seal and glass with soapy solution to aid in installation of glass.

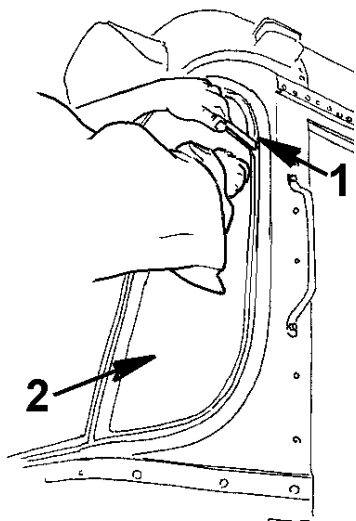

Figure 176 Inserting Wing Panel

1. WINDSHIELD FLAT TOOL WORKING SEAL PERIMETER
2. DRIVER WING PANEL GLASS

- d. Using flat stock glass tool or other appropriate glass tool, work seal around the outside edge of the wing panel glass. Pressure should be applied against glass to fit glass into seal.
- e. Continue around the exterior perimeter of panel or wing glass until entire panel is seated on window frame section.
- f. Follow the same procedure on the inside of the wing panel ensuring the glass is inserted in the seal assembly.
- g. Follow the same procedure for the opposite side wing panel (if necessary).

4.

Windshield Lace / Lock Seal

The recommended windshield lace insertion tool : **Lock Strip Straight Tool, Part number 201-1127 from Sommer Maca.**

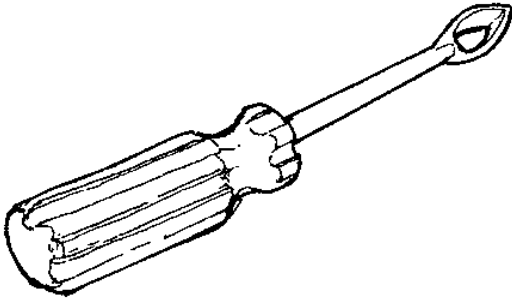

Figure 177 Windshield Lock Lace Tool

A sufficient length of windshield lace should be on hand for installation. A single piece length is required to fit the entire perimeter of the windshield opening. Two additional sections for the vertical panels between the windshield and wing panels are required. Prior to installation find the center of the lace perimeter section and place at the approximate center of the windshield seal at the top of the windshield.

- a. To install the lace rubber into the seal, use the lacing tool by threading the lace rubber into the tool. Depending on the method used and the direction in which the lace is installed will determine whether the tool is pushed or pulled while inserting the windshield lace.

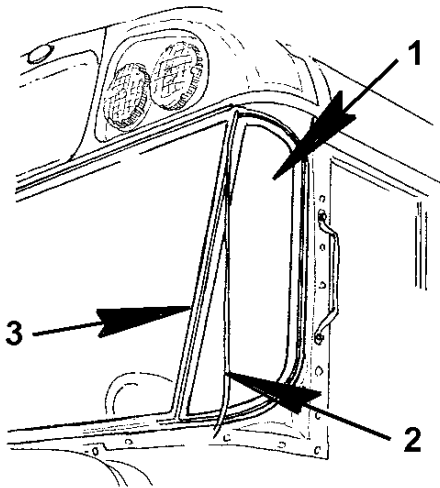

Figure 178 Windshield Lace Installation

1. WING PANEL GLASS
2. VERTICAL WINDSHIELD AND WING PANEL SEAL
3. LOCK LACE

- b. After installation of the surround lace, install the two remaining vertical pieces between the panel glass sections and the center windshield panel.

- c. A foam type glass cleaner or mild soapy solution and some water can be used to lubricate the rubber seal. This will ease installation of the lace rubber.
- d. Inspect the installation and clean off the surface of the glass, both inside and outside the bus.
- e. A pliable windshield seal may be used to seal the rubber and glass.

Driver Side Rear View Mirror

Check mirrors for cracks or any type of damage prior to installation. If the mirrors have a heater element option, check the wires and plug for breaks in the harness wire or cracks.

1. Beginning on the drivers side of the bus body, locate and align the mounting holes in the mirror and bus body.
2. Insert the four mounting bolts (Fig. 10, Item 3) and hand tighten.
3. If the mirror has the optional mirror heater, locate the harness wire (Fig. 10, Item 2) and insert through the grommet in the body section. Connect the mirror harness plugs in the appropriate harness connections in the upper corner of the electrical compartment located under the drivers window on the exterior of the bus.
4. Tighten the mirror mounting bolts to the required torque value.
5. Enter the bus, open the drivers sliding window and adjust the mirror to the proper settings.

Passenger Side Rear View Mirror

Prior to installing the passenger side rear view mirror (Fig. 11), check the mirrors for cracked mirror glass or any harness damage.

1. Place a step ladder at the passenger side of the bus body by the passenger entry doors.
2. Locate the mounting holes for the mirror support brackets (Fig. 11, Item 1) and hand tighten along the header above the top of the windshield assembly.
3. Align the mirror support bracket mounting holes with the header mounting holes, insert the bracket mounting bolts.
4. Locate the mirror base mounting holes on the "A" pillar forward of the side entry door. Align the mirror base with the mounting holes and insert the four mounting bolts. Hand tighten.
5. Attach the passenger side mirror support clip bracket to the mirror arm. Insert the attachment bolt, washer and lock nuts as required.
6. Adjust the mirror position and tighten all mounting bolts to the required torque.
7. If the mirror is equipped with optional heater element locate the mirror harness and insert into body harness hole. Install grommet on mirror harness, and insert grommet in opening.
8. Locate the mirror heater element harness and plug in the mirror connectors. Replace the "A" pillar cover.
9. Install the passenger side "A" pillar cover on the inside of the bus body. insert mounting screws in pillar cover, tighten. Install "A" pillar plastic cap covers over mounting screws.
10. Check mirror for adjustment, adjust as necessary.

Front Warning Lights

Replacement of the upper front warning lights on the face of the front end cap.

1. Tilt the hood forward. Using a step ladder to allow access to the end cap light locations, insert the warning light wire harness through the grommet.
2. Connect the warning light plug into the harness plug and insert in body opening.
3. Insert the grommet into bus end cap. Feed excess wire through grommet into the end cap.
4. Place warning light on end cap and align mounting holes.
5. Insert mounting screws and tighten.
6. Locate the warning light lens on the light assembly, insert the lens mounting screws and tighten.
7. Follow the same procedure for replacement of all other warning light assemblies on end caps.

Destination Sign



WARNING – Always wear eye protection and other safety equipment when handling glass to minimize the risk of injury.

The back lit destination board if previously removed because of damage to the glass area should be replaced only with IC Corporation authorized replacement parts to ensure the proper fit and operation.

To ease installation, the rubber gasket can be heated with a non-flame source (heat gun). At high temperatures, the rubber gasket is more pliable. Do not heat above 125 degrees Fahrenheit for longer than one and a half hours.

Avoid contacting the glass with anything that may chip or crack the edges. Pressure on the glass will tend to concentrate at the chipped areas, causing cracks. If the glass is chipped, the edge should be ground smooth prior to installation.

1. Tilt the hood to forward position, cover engine components to protect from any dirt or debris.
2. The glass destination sign is installed utilizing an “H” type glass seal. Locate the seal to be installed and check the seal for breaks or cracks.
3. For large installations such as the windshield glass, install the rubber gasket or seal onto the flange of the glass opening. For smaller applications, such as the entrance door, the rubber gasket should be located on the glass itself.
4. Insert the hook end of the windshield installation tool into the seal and work the glass into the opening.
5. With the glass seated in the seal check the fit around the perimeter of the glass for distortion or cracks.
6. To install the lace rubber into the rubber gasket or seal, use the lacing tool by threading the lace rubber into the tool and installing the rubber.

7. Pull the lace rubber around the gasket, feeding the lace rubber into the tool using a hitching motion. This will help prevent the lace rubber from stretching.
8. A foam type glass cleaner or a mild soap and some water can be used to lubricate the rubber gasket. This will ease installation of the glass lace rubber.
9. Inspect the installation and clean off the surface of the glass.
10. Seal the rubber gasket and glass with a pliable windshield type sealant.

D.O.T. Lights and Reflectors

The D.O.T. reflectors mounted on the exterior of the body as required by F.M.V.S.S. must be replaced if cracked or broken.

1. To replace a damaged reflector, locate the mounting hole of the removed reflector (Fig. 102, Item 1).
2. Insert the mounting screw through the center hole of the reflector and mounting hole in the bus body. Tighten the mounting screw till snug.
3. Broken D.O.T. marker lights or lens must be replaced if broken or damaged.
4. Locate the lens mounting hole, insert the lens mounting screw, and align with the mounting hole on the marker light assembly.
5. Tighten the marker light lens mounting screw.
6. If the light assembly was broken and removed, locate the marker light mounting hole on the bus body.
7. Locate the harness and plug in the new marker light connector. Insert the marker light wire through the body grommet and insert the grommet in the body panel.
8. Align the marker light mounting hole with body mounting holes. Insert the mounting screws and tighten. Replace the lens cover (see step 4).

Vandal Lock

The Vandal lock assembly is located at the front panel above the passenger side transition panel forward of the passenger entry door (if equipped).

1. Prior to installing the vandal lock assembly through the bus body panel, install the jam nut and washer on the assembly stem. Allow extra length for mounting the exterior mounting nut and washers.
2. Install the vandal lock assembly from inside the bus body by sliding the assembly stem through the opening in the body panel.
3. Install the exterior lock washer and threaded collar.

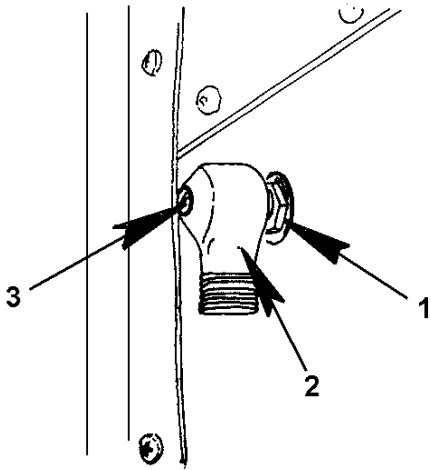

Figure 179 Vandal Lock Install

1. EXTERIOR JAM NUT LOCK WASHER
 2. EXTERIOR JAM NUT
 3. SWITCH HANDLE MOUNTING SCREW
4. From inside the bus slide the interior lock washer against the body panel. Tighten the jam nut against the washer and body panel.
 5. Connect the vandal lock wiring leads to the harness connection (Figure 104).
 6. Check the assembly from outside the bus to ensure a snug tight fit.
 7. Replace the dash panel.
 8. Locate the mounting holes at the lower joint of the passenger entry dash panel and the lower edge of the right wing switch panel.
 9. Locate the 2 dash panel mounting holes at the leading edge of the dash panel by the bottom edge of the windshield assembly.
 10. Align the 2 dash panel mounting holes and insert the two mounting screws. Tighten the mounting screws to the torque value required.
 11. Locate the mounting screws along the lower edge of the dash panel, insert the mounting screws and tighten.

Assist Steps

The assist steps (Fig. 16, Item 2) are mounted each side of the bus body directly behind the front fender extension and below the transition panel.

1. Locate the assist step body mounting holes and align the assist step assembly bracket holes on the body holes.

2. Insert the two mounting bolts through the bus body panel.
3. Install the lock nuts and washers behind the panel and tighten to the required torque value.

Passenger Entry Door

Installation of the passenger entry doors may require the help of an assistant when aligning the pivot pins and blocks.

1. With an assistant, place the forward door in the upright position at the door opening. Insert the upper pivot pin in the overhead header opening (Figure 153).
2. Locate the lower pivot block and slide on lower pivot pin, align pivot block mounting holes with mounting holes in lower step door opening cross bar.
3. Insert the mounting bolts in the pivot block and support bar (Fig. 153, Item 2).
4. Check door in position and pivot points, and ensure door swings freely.
5. Locate the door mounting bracket attached to the door opener drive arm. Align the bracket mounting holes with the mounting holes in the upper portion of door frame.
6. Insert two mounting bolts and tighten to required torque.
7. Follow the same procedure on opposite door if applicable.

Fuel Fill Door

Depending on the location of the fuel tank assembly the fuel door may vary in location. All fuel doors have a positive closure spring, and may be equipped with a latching device or keyed lock. Locate the opening where the fuel fill door assembly is to be installed.

1. Locate the fuel fill door assembly over the opening in the bus body side panel.
2. Align the mounting holes in the fuel fill door assembly with those in the bus body side panel.
3. Insert the six mounting screws in the fuel fill door assembly and tighten (Fig. 108, Item 1).

Passenger Windows

Passenger windows and related hardware are installed from the inside of the bus body. Reference Body Interior installation section.

Emergency Exit Windows

Emergency exit windows and related hardware are installed from the inside of the bus body. Reference Body Interior installation section.

Emergency Exit Doors and Latches

The rear emergency exit door is a flush mounted door assembly with interior recessed hinges.

1. Prior to installing the door assembly, check the door seal for cracks and or breaks in the material. Replace if necessary.

2. With an assistant locate the emergency exit door in the bus body door opening.
3. Locate the hinge assemblies on the inside of the door assembly. Rotate the door hinge assemblies out and align with the hinge mounting plates on the inside of the door frame assembly.
4. Locate the mounting bolts in the hinge assembly (Fig. 111, Items 1 and 2) and hand tighten. Open the door and close to check for door fit in the opening. Adjust the door assembly as may be required. Tighten the hinge bolts, install the remaining hinge bolts, and torque to the required value.
5. Check the alignment with the door latch assembly and the buzzer plunger switch.
6. If the door is aligned and functional, install the plastic hinge covers on the interior hinge assemblies.
7. Locate the mounting holes in the plastic covers, and align with mounting holes in bus body.
8. Insert mounting screws and tighten.

Roof Mounted Escape Hatch



WARNING – To avoid personal injury or death always use a secured scaffold assembly and safety restraints when servicing the bus roof panels or roof component accessories. An assistant should be present during any roof or roof accessory repair procedures.

Check the roof surface around the opening of the emergency roof hatch assembly. Make sure no sharp edges or foreign materials are present when installing sealer or the hatch assembly.

1. Clean the roof area around the hatch opening prior to any installation procedure.

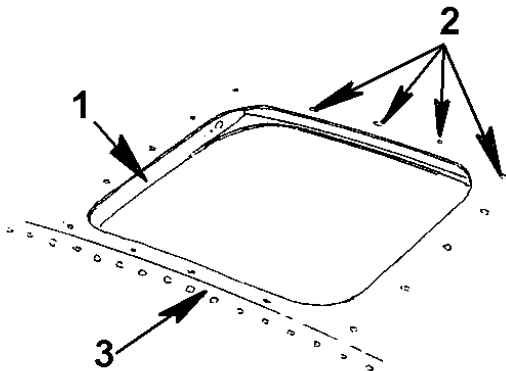

Figure 180 Emergency Roof Escape Hatch Opening

1. ROOF HATCH CUT OUT SECTION
2. ROOF HATCH MOUNTING HOLES
3. ROOF PANEL OVERLAP SECTION

2. Locate the roof hatch assembly on the opening and align the hatch mounting holes with the mounting holes in the roof section.

3. Apply any sealer required to the roof or hatch assembly prior to fastening the hatch assembly in place.
4. Install the emergency escape hatch in the opening.
5. Align the mounting holes in the hatch perimeter frame and the mounting holes in the roof panel.
6. Using an industrial type rivet gun, insert the rivet in the mounting holes and secure the hatch assembly to the roof structure.
7. Install plastic fastener covers over fasteners on the hatch assembly.
8. Apply sealant around the outside perimeter of the hatch assembly at the roof line.
9. Connect hatch open alarm switch harness to bus harness connectors.
10. Install the interior trim ring in the ceiling, insert mounting screws and tighten.
11. Place plastic insert caps over the mounting screws.

Wheel Chair Access Door

Prior to installing the wheel chair access door, check the door seals for cracks or breaks in the door seal. Replace if necessary.

1. With an assistant place the access door in the door opening. Check the alignment of the hinge mounting holes with the mounting holes in the bus body. Adjust the door as may be required.
2. Install the door hinge mounting bolts and hand tighten. Recheck the door alignment and seal for proper fit.

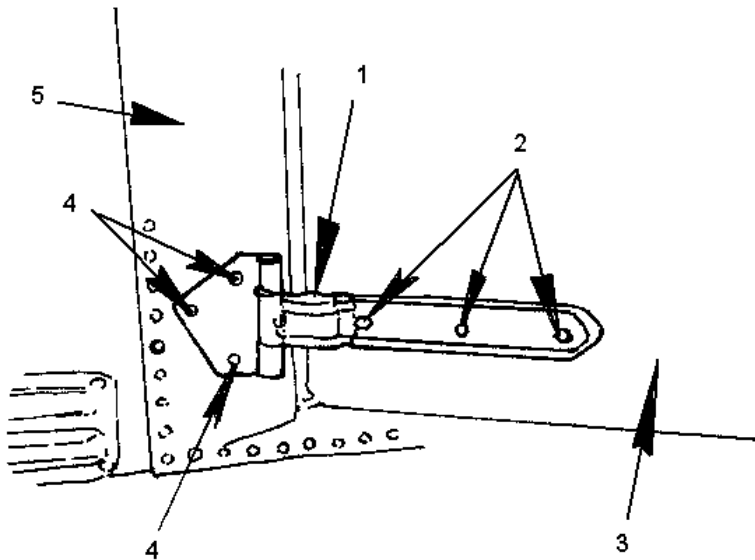

Figure 181 Wheel Chair Lift Access Door Hinges

1. ACCESS DOOR HINGE
2. DOOR HINGE ATTACHMENT SCREWS
3. ACCESS DOOR
4. DOOR FRAME HINGE MOUNTING SCREWS
5. DOOR FRAME ASSEMBLY

3. If the door fits securely, tighten and torque door hinge mounting bolts to required torque values.
4. Check the door latch alignment, ensure proper latching and locking.
5. Check the alarm buzzer assembly plunger for proper alignment and operation.
6. Adjust as necessary.

Rear Bumper Assembly

An assistant is required for rear bumper installation.

1. With an assistant locate the bumper to the rear of the bus body and align the rear mounting holes (Fig. 115, Item 2) on the bumper with those on the rear frame bumper mounting bracket.
2. Insert the upper mounting bolts through the bumper into the bumper mounting bracket. Install the bumper mounting bolt nuts and washers on the mounting bolts and hand tighten.
3. Locate and install the lower rear bumper mounting bolts through the bumper and mounting bracket.
4. Install the mounting nuts and washers on the bumper mounting bolts and hand tighten.
5. Locate and install (Fig. 115, Item 1) the remaining side bumper mounting bolts (2 each side) with nuts and washers. Hand tighten side bumper mounting bolts.

6. Check the alignment of the bumper assembly with the body. Locate and align the bumper transition panels at each end of the bumper assembly and side body panels.
7. Tighten all bumper mounting bolts and lock nuts to the required torque value.
8. Install the bumper transition panel mounting screws and tighten.

Rear Body Exterior Lights and Warning Lights

The rear body warning lights and standard stop / tail, directional and back-up lights all follow the same removal and install procedure.

A step ladder is required to access the warning light mounted on the end cap assembly.

1. Locate the end cap light mounting locations. Insert the warning harness wire and connector through the grommet.
2. Connect the warning light plug into the harness plug and insert in body opening.
3. Insert the grommet into bus end cap. Feed excess wire through grommet into the end cap.
4. Place warning light on end cap and align mounting holes.
5. Insert mounting screws and tighten.
6. Locate the warning light lens on the light assembly (Fig. 118, Items 1 and 2), insert the lens mounting screws and tighten.
7. Follow the same procedure for replacement of the stop / tail lights, back-up lights and directional lights.

Street Side Body Stop Signs

Prior to mounting optional street side body stop signs, check the wiring harness connectors and the wiring access hole for proper grommet fit.

1. Locate the wire harness connection and plug into the body harness. Feed the excess wire through the grommet.
2. Locate the stop sign mounting holes in the body side sheet. Align the stop sign assembly mounting holes with the body holes (Fig. 119, items 1 and 2) and insert the mounting screws as required (Fig. 120, Item 3).
3. Tighten the mounting screws.

Rubber Fenderettes

With an assistant, locate the rubber fenderette at the rear wheel well opening.

1. Locate the mounting holes in the fenderette, and align with the mounting holes in the wheel well opening trim ring (Fig. 121, Item 1).
2. Begin inserting the mounting bolts approximately every fourth bolt with washer and lock nut and hand tighten. There are 21 per side. With the pilot mounting bolts in place, install the remaining mounting bolts, washers and lock nuts.

3. Tighten all remaining nuts and recheck the fenderette alignment around the wheel well opening.
4. Torque all the lock nuts to the required torque value.

Under Body Compartments

The under body compartments can be installed without the door assemblies in place.

1. With an assistant, locate the body compartment in the area of the compartment opening. Using a hydraulic lift or other mechanical means, raise the compartment assembly in place.
2. Locate the door frame assembly on the body side panel and align the mounting holes.
3. Insert the mounting screws through the door frame face plate assembly holes (Fig. 122, Item 2) and tighten.
4. Locate the luggage box hanger bracket on the rear of the compartment assembly.
5. Install the “J” clip around the upper flange of the chassis frame rail. Locate the bracket mounting hole and the rear bracket hanger mounting hole.
6. Insert the mounting bolt through the frame bracket and compartment hanger bracket. Install the washer and lock nuts as required. Tighten the underbody “J” clip mounting bolts at the compartment mounting bracket.

CAUTION – To avoid damage to vehicle electronic components, disconnect both battery positive (+) and (-) negative cables prior to any welding operations. Attach the welding ground cable as close as possible to the part being welded. If necessary to weld close to an electronic component, it is recommended that the component be temporarily removed.

7. Check the surfaces on the flange edges of the compartment and the surface area of the floor structure where the compartment flange surface and the floor structure surface meet. Ensure that both surfaces are clean and free of dirt, undercoating or debris, prior to spot welding the compartment flanges in place.
8. When the compartment assembly has been welded in place, torque the “J” clip mounting bolts to the required torque value.
9. Clean all surfaces and undercoat or paint as necessary.
10. Seal all overlap joint seams with yellow sealer. Allow to dry before painting.

Electrical Compartment Door

Prior to installing the electrical compartment door assembly, check the door seal for breaks and or cracks that might cause a leak problem into the chassis electrical compartment.

1. Locate the door assembly hinge mounting holes and align them with the hinge mounting holes. The hinge assemblies are slotted for door adjustment.

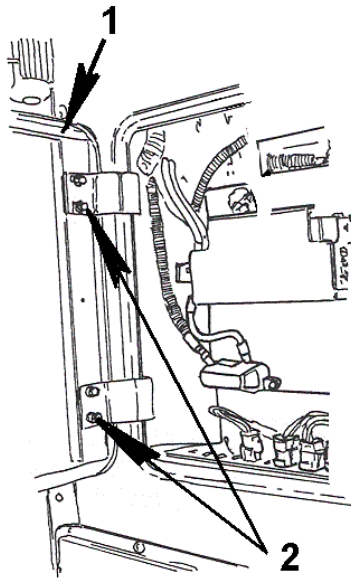

Figure 182 Electrical Compartment Door Installation

1. ELECTRICAL COMPARTMENT DOOR ASSEMBLY
2. ELECTRICAL COMPARTMENT DOOR / HINGE MOUNTING NUTS

2. Insert the hinge mounting bolts and nuts and tighten.
3. Close the electrical compartment door and check the seal and fit. If necessary loosen and adjust the mounting bolts and nuts in the hinge slots.

Battery Compartment

IMPORTANT – Excessive voltage or current applied to electronic components may damage or destroy them, resulting in expensive repairs.

CAUTION – To avoid damage to vehicle electronic components, disconnect both battery positive (+) and (-) negative cables prior to any welding operations. Attach the welding ground cable as close as possible to the part being welded. If necessary to weld close to an electronic component, it is recommended that the component be temporarily removed.

The battery compartment face plate is mounted to the outside skin of the bus body panel and is mounted utilizing with Phillip head mounting screws along the front face perimeter.

1. Prior to installing the battery compartment assembly, check the floor structure flanges for undercoating, paint, dirt and or debris. Clean surfaces where attachment points are to be welded in place.
2. Locate the battery compartment in the opening and support in place by jacks or other mechanical means.
3. Locate and align the mounting holes on the front face of the compartment assembly with the holes in the body side panel.

4. With the floor structure flanges clean and free of dirt and debris, spot weld the battery compartment mounting flanges to the floor structure flange assembly.
5. Install the battery tray and related hardware.

Radio Antenna

The entertainment radio antenna connection mounting is directly behind the drivers side widow (if equipped) (Figure 31).

1. Feed the antenna wire through the body opening with grommet on antenna wire. Insert grommet in body opening as required.
2. Locate the antenna mounting holes on the body, align the antenna mounting base and insert the mounting screws.
3. Tighten the mounting screws, and plug antenna end into radio.

Driver Side Sliding Window

The driver sliding window assembly is an aluminum extruded framed horizontal sliding dual panel window. The window individually slides forward and aft in the window frame. The window is secured with a positive latching device.

To install the driver sliding window:

1. Prior to installation check the window frame and opening for old sealant, dirt and or debris. Clean as necessary.
2. Place the driver storm window assembly into the window frame opening.
3. Locate the (4) frame mounting screws located in the bottom extrusion, (2) screws on the forward vertical frame and (3) screws across the top lip flange.
4. Insert the (4) mounting screws on the bottom of the window assembly extrusion. Tighten the mounting screws.
5. Locate the mounting holes in the forward vertical extrusion, insert the two mounting screws and tighten.
6. Install the mounting screws along the top extrusion of the window frame.
7. Double check the window for fit and apply seal around window frame area as may be needed.

Driver Side Storm Window (Optional)

The driver side storm window procedure follows the same procedure as listed above.

Transition Panels

The transition panels are comprised of two assemblies, driver side and passenger side panels. Prior to installation check the surface areas for any caulking or seal that may remain from the removed panels.

1. Align the transition panel mounting holes with mounting holes in the cowl and body panels.
2. Insert the top mounting screws in the cowl panel and hand tighten (Fig. 126, Item 1).

3. Check the alignment of the rear edge of the transition panel with the body mounting holes. Beginning at the top of the transition panel align and insert mount screws in the transition panel rear cover reinforcing strip (Fig. 126, Item 2 and 4).
4. Locate the bottom recessed mounting screw in the lower center recessed mounting hole and tighten (Figure 126, Item 5).
5. Check the perimeter of the transition panel for any gaps and re-adjust if necessary.
6. Apply sealant along the rear edge of the rear transition panel reinforcing strip as needed.

End Caps

The end caps on the front and rear of the bus body are replaceable. Care should be taken in the process or removal and installation of the assemblies.



WARNING – To avoid personal injury or death always use a secured scaffold assembly and safety restraint when servicing the bus roof panels or roof component accessories. An assistant should be present during any roof or roof accessory repair procedures.

NOTE – When replacing end caps, some interior panels are required to be removed to drill pilot holes through the roof bows, for the end cap attachment process.

When replacing the front cap assembly, the driver bulkhead compartment and any equipment mounted on it will have to be removed to access the roof bow assembly.

This includes:

- Optional defroster fan assemblies.
 - First aid kits and Body fluid clean-up kits.
 - Driver interior rear view mirror and sun visor (if applicable).
 - Exterior light check system (if applicable).
 - The forward ceiling panel or rear depending on end cap being replaced.
 - Any other items that may be options that would be mounted on the driver overhead bulkhead.
1. With the applicable interior items removed, mount the forward end cap on the roof assembly and header assembly.
 2. Insert bolts in the lower forward edge and corners of the end cap assembly. Check the fit and alignment with the roof panels.
 3. From the inside front section of the bus, drill through the roof bow and roof panel holes, through the end cap assembly.
 4. With the roof bow holes drilled, prior to installing pilot rivets, install sealer adhesive along the existing roof panel and under the rear edge of the end cap.
 5. Install pilot rivets across roof bow to ensure alignment.

6. Beginning at the front corner over the windshield install rivets through the new end cap mounting holes (Fig. 36, Item 5) into header assembly and side section over driver window frame and entry door frame.
7. Insert the remainder of roof bow rivets as required and check joint seals at end cap and front roof panel.
8. If end cap seats properly, re-install interior bulkheads, and equipment that may have been removed.
9. Re-install the front windshield assembly (see windshield installation).
10. Install the end cap marker light and connect marker light harness plugs.
11. Seal all seams prior to paint.
12. If bus is equipped with glass destination board, install the glass panel and seal as described in section.

Follow the same basic procedure for rear end cap. Rear emergency door and windows need not be removed.

Static Roof Vents



WARNING – To avoid personal injury or death always use a secured scaffold assembly and safety restraint when servicing the bus roof panels or roof component accessories. An assistant should be present during any roof or roof accessory repair procedures.

1. Locate the static roof vent opening in the bus roof . Check the edges of the opening for old seal gasket material or sharp edges.
2. Locate the static roof vent and gasket assembly on the roof aligning the mounting holes in the roof vent and the roof (Fig. 132, Item 3).
3. Using an industrial type rivet gun, insert the rivets through the static roof vent flange into the roof panel assembly.
4. Seal as necessary and allow seal to dry before painting.

Optional Roof Mounted Warning Lights

Roof mounted clear strobe light assembly (Figure 34).

1. Prior to installing the roof mounted strobe light, ensure the surface is clear and clean of any dirt or debris.
2. Locate the strobe light harness connection plug, and the body harness connection. Connect the plug assemblies, install the body grommet on the harness wire and insert in the body opening.
3. Locate the mounting gasket and place on body section. Align the mounting holes on the light base and insert fasteners.
4. Tighten fasteners and check gasket for proper seal.

Body Attachments or Tie Downs

The body attachment tie downs are mechanical fasteners that secure the body floor panels to the chassis frame rail. This application consists of a combination of body tie down clips.

CAUTION – Failure to properly torque tie down bolts can result in body damage.

“J”-Clip

1. Check for anti-squeak pad. If it is missing, install. Locate the 1/2”-13 x 13 in “J”-clip and bolt around the chassis frame rail and insert in floor frame structure (Fig. 127, Items 1, 3 and 4).
 - a. Install the washers and lock nuts.
 - b. Torque the “J”-clip bolt to 30–40 Lbf-ft. (see Torque Chart).

Shear Bolt Tie Downs

2. Locate the shear bolt mounting angle at the upper section of the bumper mounting bracket assembly and chassis frame rail (Fig. 128, Item 3).
 - a. Align the mounting holes in the shear angle assembly with the holes in the floor structure flange.
 - b. Insert the 1/2”- 13 x 13” mounting bolts, washers and lock nuts.
 - c. Torque the mounting bolts to 30–40 Lbf-ft.

Formed Tie Down

3. Locate the formed tie down end in the notch in the floor flange structure. Locate the opposite end under the frame rail flange (Fig. 129, Items 4 and 5).
 - a. Locate the 1/2”-13 x 2 1/2” bolt through the formed tie down and floor structure flange.
 - b. Install the washer and lock nut and tighten to 30–40 Lbf-ft.

Front Tie Down (Outrigger Tie Down)

4. Locate the mounting hole in the drivers platform frame assembly. Insert the 1/2”-13 x 4” mounting bolt through the compression spring and through the driver platform frame mounting hole (Fig. 130, Item 4 and 5).
 - a. Install the flat washer and mounting nut. Torque to 50–60 Lbf-ft.

4.2. INTERIOR INSTALL

The procedures outlined in this section are the general procedures for the standard items and select options that are most commonly specified.

Step Well

The step well assembly is secured to the floor substructure, body side panel and driver substructure frame. Because portions of the step well assembly are spot welded in place, take the proper precautions in the disconnecting the battery system.

1. Prior to installing the step well assembly, check the floor for holes from the previous step well mounting. If pre-existing holes are found, fill the holes and seal the under structure to prevent leaks that could lead to rust and/or other deterioration.
2. Align the step well in position with the step well opening. Prior to spot welding the assembly in place, ensure that all surfaces are clean and free of dirt and/or debris.
3. After the step well assembly is spot welded in place check for open gaps that may allow moisture in the interior.
4. Seal any open areas.
5. Check the understructure for clean areas to spot weld the step well assembly to the structures as needed.
6. All undercoating and paint if applicable should have been removed from the area surrounding the step well mounting points.
7. Prior to installing the step well, mark and cut out the openings for any courtesy lights that may be mounted in the step well.
8. With the step well spot welded and screwed into place, re-install the flooring material and trim pieces.
9. Relocate the step well assist handrail brackets, drill and mount the handrail base assembly.
10. Remount the passenger entry door assembly, check the alignment of the doors and lower mounting blocks on door cross frame structure.

Assist Handrails

The assist handrail located on the left side of the entry step well is the standard location for the assist rail. An optional assist rail is located on the forward step well bulkhead.

To install the standard step well assist handrail;

1. Locate the hex head mounting hole at the crash barrier panel hand rail attachment point.
2. Insert the hex head mounting screw and tighten.
3. Locate the mounting screws on the lower step well handrail mounting brackets, two on each bracket.
4. Insert the mounting screws. The assist handrail assembly can be mounted in the handrail mounting brackets.
5. Install the stainless steel handrail in the mounting brackets, locate the set screw on the handrail assist mounting bracket.
6. Tighten the set screw to secure the handrail.
7. If the bus is equipped with the optional assist handrail, follow the same basic procedure as outlined in steps 3 through 7.
8. The top mounting bracket for the forward mounted handrail will be attached with a mounting screw attachment to the forward dash vertical support bracket or the step well optional heater side cover plate.

Defroster Fans (Optional)

The optional defroster fan or fans are mounted on the bulkhead over the windshield area. The fan mounting base is the ground circuit.

1. Locate the mounting holes in the base of the 12 VDC defroster fan, align the fan base mounting holes with the mounting holes in the bulkhead assembly (Fig. 87, Item 1)
2. Install the mounting screws and tighten.
3. Connect the wire leads to the harness connection through the grommet in the bulkhead panel.
4. When connecting the fan circuits the black wire lead is for low speed, the red wire lead for high speed.
5. Adjust the fan direction by loosening the spring adjustment screw. Tighten the adjustment screws when fan is in desired position.

Sun Visor

The sun visor mounts to the overhead structure above the driver position.

1. Locate the sun visor assembly bracket on the overhead panel above the driver position.
2. Locate the mounting holes in the overhead assembly, align the sun visor mounting bracket holes (Fig. 135, Item 2).
3. Install the mounting screws in the brackets and into the overhead panel.
4. Hand tighten all other sun visor fasteners.
5. Torque all fasteners until tight and still adjustable.

Destination Sign Lights (Optional)

On busses equipped with lighted destination boards front and rear, the light bulbs and socket assemblies are located in the compartment over the windshield in the bulkhead compartment. To replace the bulbs:

1. Open the latching devices on the panel door and lift panel.
2. Locate the light bulb socket assemblies (6).
3. Remove the burned out bulb or bulbs and install new bulbs.
4. Turn on the bus lights to activate the destination board lights. Check bulbs.
5. Close compartment door and secure latches.

Interior Rear View Mirror

Prior to the installation of replacement glass, the glass should be inspected for small chips. If chips are found, do not install.



WARNING – Always use safety equipment and eye protection when removing or working with glass.

1. Place the mirror glass section on the backing plate. Install the rubber perimeter strip.
2. Install the metal backing plate assembly on the bulkhead mounting bracket. Align with the bulkhead mounting bracket holes (Fig. 137, Item 2), both right and left side.
3. Insert the fasteners and hand tighten.
4. Adjust mirror to proper position for driver and tighten lock nut.

Dash Board Panels, Cluster and Switch Panels

Prior to installation of the dash panels, check all harness connections, check the defroster duct installation and heater connections.

Driver Side Storage Compartment

(Fig. 49)

1. Place the driver storage compartment assembly in place, connect the 12 volt power receptacle plug at the bottom of the storage compartment.
2. Locate the 6 mounting screw holes in the bottom of the driver storage compartment (Fig. 143, Item 2), insert the mounting screws and tighten.

Heater and Environmental Controls

(Fig. 45, Item 2)

3. Connect the heater, defroster and fan control harness to the system harness.
4. Locate and install the heater, defroster and recirculation control panel (Fig. 141, Item 3).
5. Install the control knobs for the environmental controls.

Driver Left Side Switch Panel

(Fig. 45, Item 3)

6. Locate and connect the driver left side switch panel and harness plugs. Connect the switch harness plugs.
7. Install the switch panel and align the panel mounting holes. Install the mounting screws and tighten (Fig. 142, Item 1).

Cluster Assembly

(Fig. 103, Item 7)

8. Place the instrument cluster in position, locate the harness connections for the instrument cluster and connect.

9. Seat the cluster and locate the cluster mounting holes and mounting screws (Fig. 140, Item 1). Insert the mounting screws and tighten.

Cluster Cover Panel

(Fig 45, Item 5)

10. Align the instrument cluster cover forward edge mounting holes with the mounting holes along the lower edge of the windshield assembly (Fig. 103, Items 1 and 2). Insert the mounting bolts and tighten.

Steering Column Cover

(S09009)

11. Locate and align the steering column cover panels. Install the mounting screws and tighten.

Right Wing Switch Panel and Cluster Bezel

(Fig. 103, Item 6)

12. Locate and install the right wing switch panel, align the panel mounting holes with the mounting holes in the panel support bracket.
13. With the panel aligned and in place, insert the panel and bezel mounting screws. Tighten the panel screws.
14. Locate any of the optional equipment mounted on the switch panel. Align with the mounting holes, insert the mounting screws (Fig. 103, Items 2 and 3), and tighten.

Step Well Panel

(Fig. 103, Item 5)

CAUTION – Prior to any installation of assemblies that have been attached to the bus interior through the floor assembly, the existing holes must be plugged or filled and or sealed prior to sub-floor installation. All fasteners that protrude the floor assembly must be painted and or under coated to prevent corrosion.

15. Place the step well dash panel in place and align the lower over lap mounting holes.
16. Align step well forward edge mounting holes (Fig. 103, Items 3 and 4) with the cluster cover / wing switch panel cover mounting hole and mounting hole at right hand windshield wing panel lower edge of the windshield assembly.
17. Install the mounting bolts and tighten.
18. Align the lower edge of the step well panel mounting holes with the mounting holes in the bus cross beam support bracket. Insert the mounting screws and tighten.

Driver Seat

Prior to installation of the driver seat assembly, the mounting hardware should be inspected, and the adjustment mechanisms should be lubricated. The seat belts should be inspected for smooth operation and secure attachment.

1. Clean the driver position platform prior to installation of the driver seat assembly. Locate and check the driver seat mounting holes in the platform area.
2. Align the driver seat mounting holes on the driver platform floor holes.
3. Insert the mounting bolts through the seat pedestal and floor (Fig. 51, Item 5).
4. With an assistant located under the driver seat platform beneath the floor assembly, install the washers and lock nuts on each of the driver seat mounting bolts. Hand tighten the mounting nuts.
5. Check the seat mounting for alignment, torque seat anchoring hardware to 20–22 Lbf-ft.

Driver Seat Belts (3–Pt Belt Install)

Check the type of driver seat (for air ride seats) installed and follow the manufacturers recommended procedure for seat belt installation. This procedure requires an assistant under the bus to install the mounting nut and washer.

1. Locate the seat belt latch assembly floor mounting bracket (Fig. 147, Item 5) and mounting bolt and washer (Fig. 147, Items 8 and 9).
2. Align the mounting bracket hole with the mounting hole through the floor on the driver platform.
3. Insert the mounting bolt and washer through belt assembly attachment.
4. With the assistant under the driver platform, install the washer and lock nut (Fig. 147, Items 2 and 3).
5. Tighten the lock nut to 40–42 Lbf-ft.
6. Locate the mounting bracket mounting hole on the left side of the driver seat platform floor.
7. Align and install the floor mounting bracket (Fig. 147, Item 6) and mounting bolt (Fig. 147, Item 5) through the bracket and floor assembly.
8. With the assistant under the driver platform, install the washer and lock nut (Fig. 147, Items 2 and 3).
9. Tighten the lock nut to 40–42 Lbf-ft.
10. Locate the seat belt harness and cover assembly floor mounting bracket (Fig. 147, Item 7 and 6) on left side of driver's position. Install the mounting bolt, washers and lock nut through the belt assembly hardware and floor mounted bracket. Torque to 10–12 Lbf-ft.
11. Locate the upper wall mounting holes directly behind the driver rear sliding glass window pillar (Fig. 146, Item 1).
12. Locate the shoulder harness assembly mounting bracket and insert the mounting bolts through the bracket and into the wall structure mounting holes, both upper and lower bracket assemblies (Fig. 146, Items 2 and 3). Torque the mounting bolts to 40–42 Lbf-ft.

Driver Crash Barrier (Rail Mounted)

NOTE – The installation of the floor mounted seat and barrier attachments can be located underneath the bus floor. An assistant is required to install the washers and lock nuts. Installation also requires torquing the fasteners to the specified values from under the bus body.

1. Locate the barrier to be installed and place the inboard (rail mounting bracket) on the chair rail along the bus side wall.

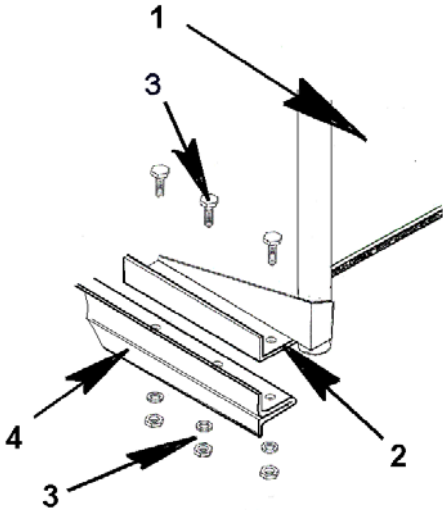

Figure 183 Chair Rail Seat Mounting

1. LOWER SEAT CUSHION
 2. CHAIR RAIL
 3. SEAT / CHAIR RAIL MOUNTING BOLTS AND WASHERS
 4. CHAIR RAIL SEAT MOUNTING BRACKET
2. Align the barrier wall bracket mounting holes on the chair rail (Fig. 148, Item 4) mounting holes. Insert the mounting bolts (Fig. 148, Item 5) through the barrier mounting bracket (Fig. 148, Items 2) and chair rail (Item 4). Install the washers and lock nuts (Item 3).
 3. Locate the barrier foot assembly (Fig. 184) mounting holes and align with mounting holes in floor.

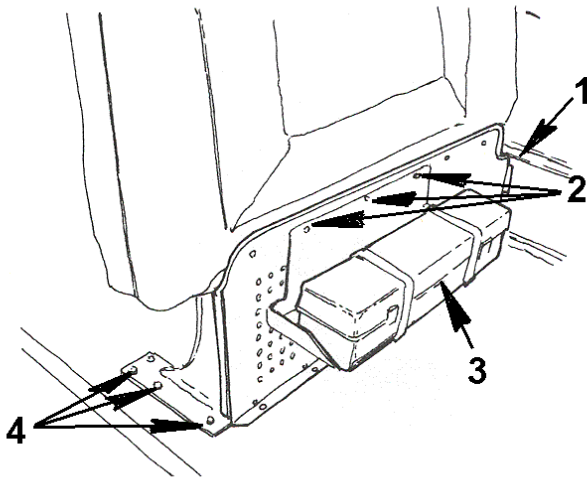

Figure 184 Crash Barrier Floor Mounting

1. BUS CHAIR RAIL ASSEMBLY
2. ROAD WARNING TRIANGLE MOUNTING BRACKET SCREWS
3. ROAD HAZARD WARNING TRIANGLE CASE
4. CRASH BARRIER FOOT MOUNTING SCREWS

4. Install the mounting bolts, washers and lock nuts as required and torque to specified value.
5. Install the entry assist handrail as required (if installing passenger side crash barrier).

Fire Extinguisher

The fire extinguisher installation may vary depending on location of the extinguisher. The extinguishers are generally mounted in the vertical position.

1. Locate the area the extinguisher is to be mounted. Mark the bulkhead or area where the extinguisher bracket will be mounted. Use the bracket mounting holes as a guide. Drill the mounting holes or use the existing mounting holes.

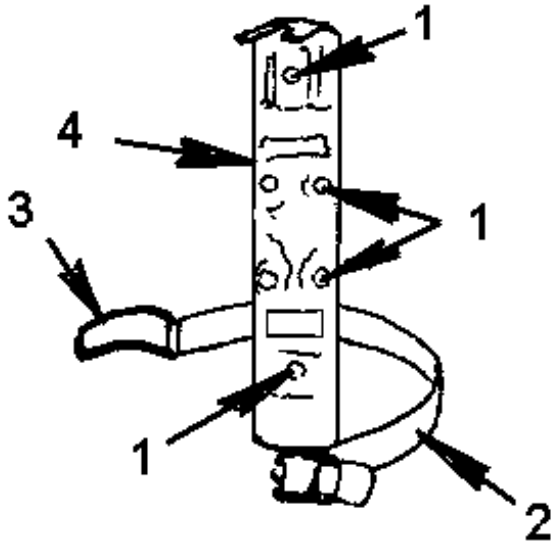

Figure 185 Extinguisher Mounting Bracket

1. FIRE EXTINGUISHER BRACKET MOUNTING HOLES
2. FIRE EXTINGUISHER RETAINER STRAP
3. EXTINGUISHER LOCK CLIP
4. FIRE EXTINGUISHER MOUNTING BRACKET

2. Align the bracket mounting holes and bulkhead mounting holes, insert mounting screws and tighten.
3. Insert extinguisher in bracket and secure strap band.

First Aid Kit

The first aid kit provided for the school bus application is designed for use from the mounted position. The kit is furnished with an upper mounting bracket and a lower spring clip retainer.

1. To mount the first aid kit locate the mounting holes in the overhead panel.

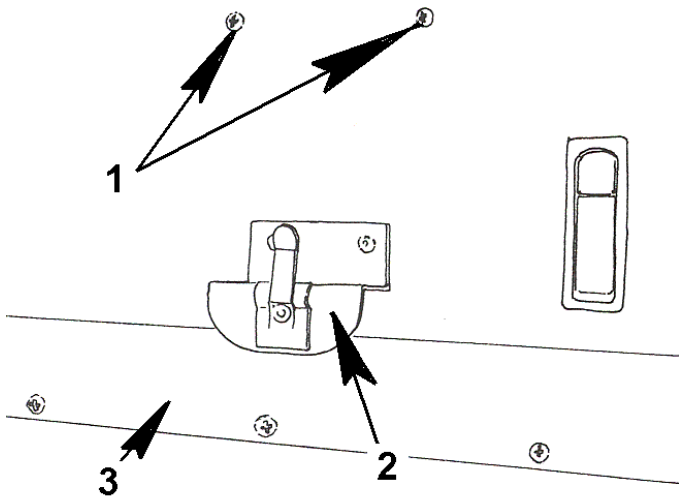

Figure 186 First Aid Kit mounting Clip and Screws

1. HANDLE MOUNTING SCREWS
2. LOCK CLIP BRACKET ASSEMBLY
3. FRONT BULKHEAD LEADING EDGE

2. Place the kit in on the lower bracket retainer assembly.
3. Insert the two mounting screws through the kit upper mounting flange and tighten the screw until the kit is snug.

Body Fluid Clean-up Kit (Optional)

The body fluid clean-up kit provided for the school bus application is designed for use from the mounted position. The kit is furnished with an upper mounting bracket and a lower spring clip retainer.

1. To mount the Body fluid clean up kit locate the mounting holes in the overhead panel.
2. Place the kit in on the lower bracket retainer assembly.
3. Insert the two mounting screws through the kit upper mounting flange and tighten the screw until the kit is snug.

Passenger Door Control Mechanism

The CE 200 and CE 300 school bus models are equipped with one of three different style or type passenger entry door opener mechanisms. The standard door opening type is the electrically operated door opening mechanism. The second style is the optional air operated door opener and the third is a manual type door opener. All three types automatically activate the student warning lights, the crossing gate and driver side stop arms.

Electric Actuated Door Opener

1. Electric Actuated Door Opener Removal

The electric door opener motor and drive mechanism are located in the compartment directly above the passenger entry door. The door operation is activated by a double switch operation on the left side of

the steering wheel. An optional two position switch is located on the left console switch panel. A manual override switch for emergency purposes is located on the door opener access panel. See bus operators manual for operational instructions.

To install the door opener use the following procedures:

- a. Locate and open the drive motor access door.
- b. Locate the six motor mounting bolts holes that secure the motor mounting bracket to the compartment structure.
- c. Install the door opener drive motor, and align with mounting holes in compartment.
- d. Insert the six mounting bolts and tighten.
- e. Locate and connect the harness plug at the upper left hand corner of the compartment.
- f. Move the emergency release lever forward to release the emergency door.
- g. Locate the drive arm on the cam gear plate.
- h. Locate the drive arm and drive arm end bushing mounting hole.
- i. Insert the mounting bolt through the bushing and gear plate.
- j. Install the lock nut attaching the drive arm to the gear plate.
- k. Tighten to required torque value.
- l. Set emergency door switch to automatic.
- m. Activate door from steering wheel switch. Check operation. If adjustment is required see door adjustment section of this manual.

Electric Door Adjustments

2. The passenger entry door has no speed adjustments. The doors do have a limit switch adjustment that sets the limits of the door opening. To adjust these limits loosen the mounting screws on the switch assembly. Move the switch in or out to set the limit of the door opening operation.
 - a. To replace either switch, set the emergency manual door opener to open.

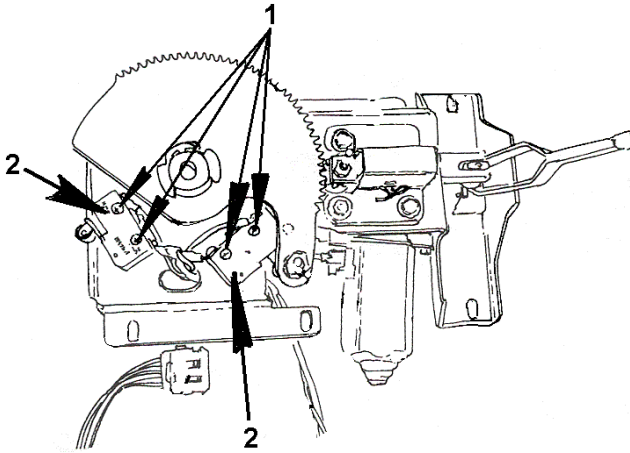

Figure 187 Electric Door Opener Adjustment- Limit Switches

1. LIMIT SWITCH MOUNTING SCREWS
2. LIMIT SWITCHES

- b. Locate the 2 Phillips head screws on the top surface of the switch. Loosen and remove screws.
- c. Remove switch. With switch removed disconnect the wire connectors to switch. Mark switch for placement of wires when reinstalling.
- d. Follow the same procedure for the opposite switch if it is to be replaced.

Air Actuated Door Opener Adjustments

Air Operated Door Opener

The air actuated door control switch is located on the steering wheel or on the left console panel. The emergency release switch is a toggle switch located on the right wing console outboard section.

The air actuated door has four major components: the regulator, cylinder, door switch and the air valve. The actuator switch is located on the steering wheel assembly or on the driver console (depending on state specifications). The switch to actuate the dump feature is located to the right of the driver side dash. Some states may require the dump feature to be located in other positions.

Door Speed Adjustment

The door speed can be adjusted at the air control valve. The air valve is located above the entrance door. To change the opening speed or closing speed follow the steps below:

Open Speed Adjustment

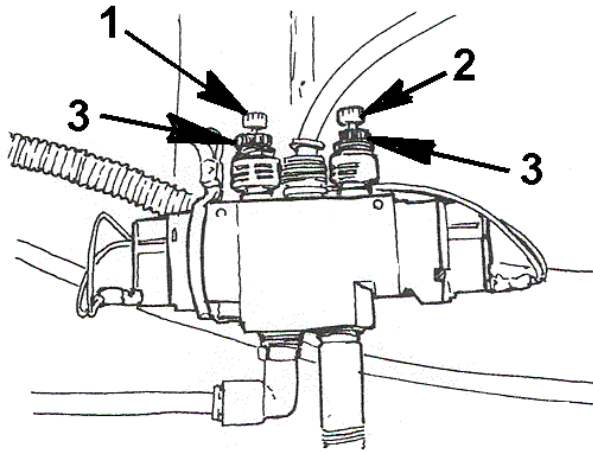

Figure 188 Air Operated Door Adjustment Valve

1. "OPEN" SPEED CONTROL SCREW
2. "CLOSE" SPEED CONTROL SCREW
3. JAM NUT

1. Use a small tip slotted screwdriver.
2. Loosen jam nut (hex head nut).
3. Locate the "open" screw and turn clockwise to slow the speed down.
4. To increase the door opening speed, turn the slotted screw counter-clockwise.
5. Tighten the jam nut.

Close Speed Adjustment

To change the close speed adjustment, use the steps below:

1. Use a small tip screwdriver
2. Loosen jam nut (hex head nut).
3. Locate the "close" screw and turn clockwise to slow.
4. To increase the opening speed, turn the slotted screw counter-clockwise

Pressure Regulator

The pressure regulator should be set at approximately 41 to 50 pounds of pressure.

1. To increase the pressure, turn the adjustment knob clockwise.
2. To reduce the pressure turn the knob counter-clockwise. **In extreme cold, the pressure will need to be increased because seals may stiffen.**

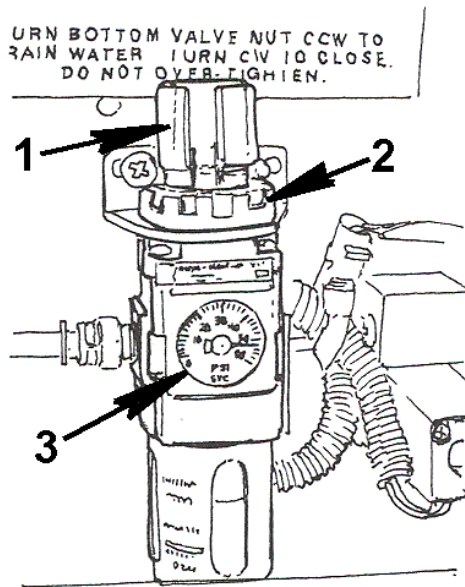

Figure 189 Air Door Pressure Regulator

1. ADJUSTMENT KNOB
2. REGULATOR MOUNTING BRACKET AND JAM NUT
3. REGULATOR GAUGE

The entrance door should take approximately four to five seconds to open and close depending on the speed setting.

NOTE – Periodic maintenance is required to torque mounting nut and wire attachment screws.

Bus Interior Light Bars

The light bar assemblies along each side of the bus body above the passenger and driver windows contain the harness for the rear bus warning, stop-tail, directional and back-up lights. They also contain the wire harness for the emergency exit door buzzers, the roof escape hatches, emergency window exits, interior bus lighting and speaker assembly wiring (if equipped).

1. Driver light bar. The driver light bar (Fig. 55, Item 1) contains the harness and connections from the chassis and body electrical compartment.
 - a. Place the light bar assembly in position over the driver window assembly. Align the mounting holes in the driver light bar and the passenger light bar assembly.
 - b. Check that the light bar cut out for the wire duct (Fig. 55, Item 5) from the electrical compartment fits properly.
 - c. Install the Phillips head screw and tighten.
2. Light bar panels
 - a. The light bar panels (Fig. 56) are located along the window line. The top flange of the light bar panel is attached to the ceiling panel.

-
- b. Install the light panel behind the passenger window top flange.
 - c. Lay the upper light bar flange against the ceiling panel, insert the mounting screw and tighten.
3. Passenger lights and speakers assemblies (Fig. 56, Items 1 and 2).
 - a. Passenger light assemblies are located above the window assemblies in the light bar.
 - b. If a light assembly is being replaced, locate the harness connection in the light bar for the light connection. Insert the light assembly connectors into the harness connector.
 - c. Place the light fixture and lens over the opening in the light bar.
 - d. Align the mounting holes and insert mounting screws.
 - e. Mounting the speaker assemblies in the light bar, locate the speaker wire connectors and attach the connectors.
 - f. Place the speaker assembly over the opening and align the four mounting screws.
 - g. Insert the screws and tighten.
 4. Light bar joint cover plate (Fig. 154, Item 2)
 - a. Locate the end sections of the two light bar panels (Fig. 154, Item 3) and install the joint cover over the panel joints. Place the lower flange behind the window top flange. Insert mounting screw in top flange of joint cover into ceiling panel.
 - b. Follow the same procedure for all other joint cover plates.
 5. Corner covers (Fig. 57, Item 2)

The corner cover light bar sections conceal the wire harness junction connectors at the rear corners of the bus body.

- a. When replacing the corner covers, ensure all harness connections are secured and out of the way.
- b. Install the corner cover over the light bar end section and flush to the inside rear cap assembly.
- c. Install the mounting screws and tighten.
- d. Torque all mounting screws until tight. Do not over tighten.

Seats

If the seat has been removed for repairs and is being re-installed to the same position use this procedure;

1. **Seat Install. An assistant will be required to install the seat mounting bolts.**
 - a. Two leg / chair rail mount (30" and 45")
 1. Align seat wall bracket on chair rail, align the mounting holes on the chair rail and leg mounting holes on the floor.
 2. Install the chair rail mounting bolts, washers and lock nuts. Tighten the chair rail fasteners.
 3. Locate the chair leg floor plate mounting holes and insert the mounting bolts through the mounting plate and floor.
 4. The mounting lock nuts and washers are installed from beneath the bus and torqued to 19–20 Lbf-ft by an assistant.
 - b. Four leg (30" and 45")

1. Locate the seat in position, aligning the mounting holes in the seat leg floor plate mounting holes with the floor mounting holes.
 2. Insert the mounting bolts through the four leg mounting plates and floor.
 3. The mounting lock nuts and washers are installed from beneath the bus and torqued to 19–20 Lbf-ft by an assistant.
- c. Child Safety seat (Optional)
1. Follow the same procedure for standard rail mount seat and four leg seat as previously outlined in steps “a” and “b”.
- d. Flip Up Emergency Exit Seat (Optional)

The flip up emergency exit seat is a four leg seat assembly.

1. Follow the same procedure as described in section “b” of this section.

Seat Cushions

Inspect all seat mounting hardware attachments. This should be performed at 30 to 45 day intervals. Inspect the seat back foam around the upper corner and in the knee impact area. If damage is discovered such as breakage or separated seals, the seat back material should be replaced without delay.

The following procedure should be used to replace seat upholstery. In most cases the seat will not have to be removed from the bus.

1. Locate the upholstery or foam on the seat board, align the foam, overlay the upholstery material and staple to the seat board.

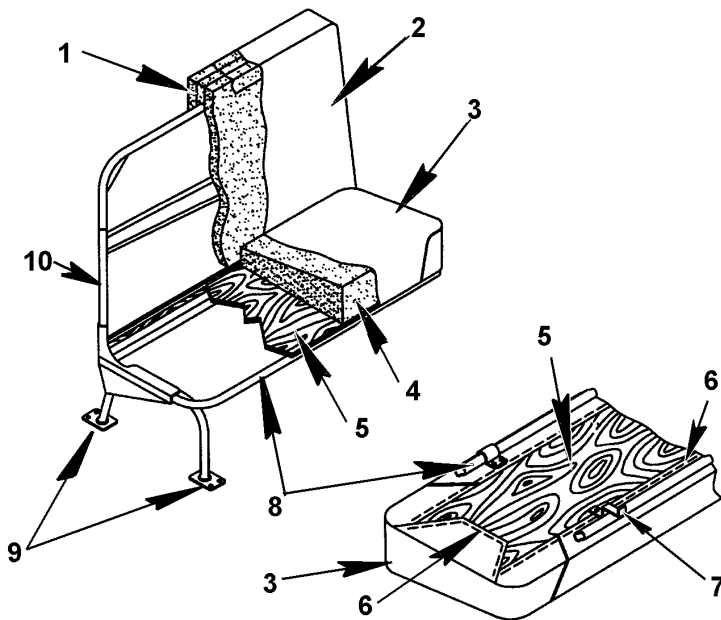

Figure 190 Seat Cushion Replace

1. SEAT BACK CUSHION FOAM
2. SEAT BACK CUSHION UPHOLSTERY COVER
3. SEAT CUSHION UPHOLSTERY COVER
4. SEAT CUSHION FOAM PAD
5. SEAT CUSHION PLYWOOD BASE
6. SEAT CUSHION UPHOLSTERY ATTACHMENT STAPLES
7. LOWER CUSHION TILT LATCH
8. LOWER SEAT TUBULAR FRAME
9. SEAT FLOOR MOUNTING FEET
10. SEAT BACK FRAME ASSEMBLY

2. Replace the seat board mounting hardware if necessary.
3. Align the seat cushion on the seat frame, insert mounting hardware screws, and tighten.
4. Insert the hinge mounting screws through the hinge assembly into seat cushion board. Tighten the screws.
5. Flip the cushion down to the ride position and rotate locking clip to secure seat cushion assembly.

Seat Back

1. With the seat cushion flipped forward, locate and install the seat back cushion (foam padding) over the seat back frame. Pull the foam panel all the way down over the frame work and ensure a tight fit.

2. Place the upholstery (seat back cover) section over the cushion and frame assembly and pull down into place.
3. Staple the material in place on the tack strip.
4. Check the end seams for adequate fit, flip seat cushion back down and lock in place.

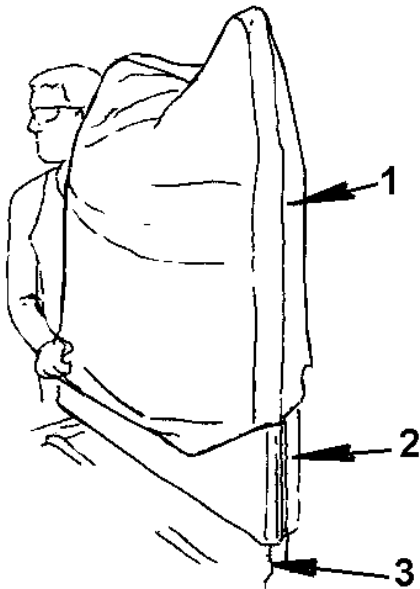

Figure 191 Seat Back Cushion Replace

1. SEAT BACK CUSHION UPHOLSTERY COVER
2. SEAT BACK CUSHION FOAM
3. SEAT BACK FRAME ASSEMBLY

Seat Tracks (Optional)

The seat track configuration may vary depending on the type seats and location.

1. If the floor has a plywood sub-floor the plywood will be routed to accommodate the seat track as part of the floor assembly.
2. Locate the slots in the plywood sub-floor and insert the seat tracks in the floor slot.
3. Locate the mounting holes in the track section and drill through the mounting holes and sub-floor assembly.
4. Insert the tapered Phillips head torque lock screw in the track and fasten into the floor system.
5. After the track is mounted, ensure that a sufficient amount of undercoat has been applied to prevent moisture from penetrating the bus integrity on the underside of the bus floor where the mounting screws have penetrated through.
6. With the seat track in place install the flooring material as required.

7. Install the seat track mounting studs according to the requirements of the state or district specifications.
8. Mount the seats on the track and mounting studs. Install the lock nuts and torque to required value.

Seat Belt— 2 Point With Seat Track (Optional)

With the seat track and seats in place insert the seat belt track mounting studs in the appropriate position by inserting the head of the track bolt in the track and slide to lock position.

1. Install seat belt ends through cushion and seat back and place end plate mounting hole on the seat track stud.
2. Install the stud mounting lock nut over the seat belt mounting plate and tighten.
3. Follow the same procedure for the remaining seat belt mounting plates on the respective mounting studs. Install lock nuts and torque.

Passenger Window Installation

Prior to installing the passenger side windows, inspect the window seat and frame for dirt, old sealant and/or debris. Clean as necessary.

NOTE – Check the window gasket material for full adhesion around the window frame prior to installation. Any cracks or breaks in the seal could result in window leaks.

1. Locate the window assembly in the window opening.

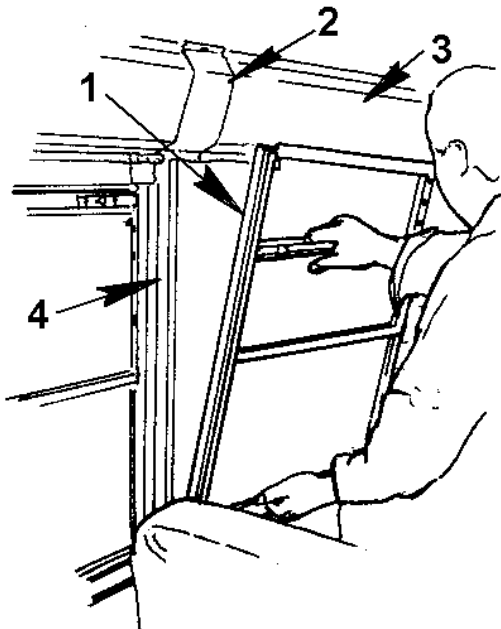

Figure 192 Passenger Window Replace

1. PASSENGER WINDOW EXTRUDED FRAME AND WINDOW ASSEMBLY
2. LIGHT BAR JOINT COVER PLATE
3. LIGHT BAR ASSEMBLY
4. PASSENGER VERTICAL WINDOW FRAME POST

2. Insert the window mounting cover plates each side of the window assembly. Install the mounting screws in the cover plates and tighten.

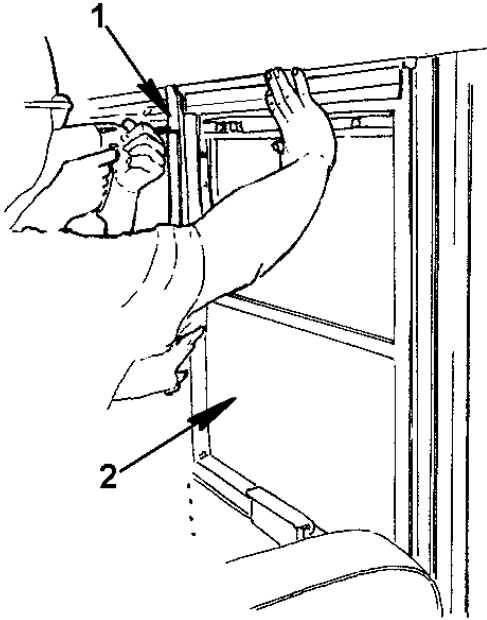

Figure 193 Install Window Cover Plates

1. WINDOW COVER PLATE
2. PASSENGER WINDOW ASSEMBLY

3. Check the window and seal for fit.
4. Apply sealant as may be required to ensure good seal and stop possibility of leaks.

Stationary Glass Install

All glass installed in this vehicle meets F.M.V.S.S. requirements. The glass should only be replaced with the same type glass. The passenger entry door glass is AS-2 tempered safety glass encased by an aluminum frame with a center latching device.

1. Check the glass for cracks and or chips before installation process.
2. Place the "H" seal around the glass panel.
3. Place glass and seal in window frame area from inside the bus body. With a flat tool seat glass and seal on the window opening lip.
4. Spray the window and seal with a soapy solution to help in the installation of the window assembly.
5. Using the window flat tool work the seal around the window frame lip.
6. Check the inside of the window and seal to ensure the window has seated. Using the same flat tool work the seal around the window perimeter to ensure proper seat.

7. Insert the window seal lock lace around the window area seal.
8. A rope in method may be used in place of working the window perimeter with the flat tool.

Emergency Exit Window Installation

Prior to installing the emergency kick-out window assemblies, inspect the window seat and frame for dirt, old sealant and/or debris. Clean as necessary.

1. Horizontally Hinged Kick-out Windows
 - a. Locate and connect the wire lead to the switch assembly below the window frame.
 - b. Locate the plunger switch and install the four mounting screws at the bottom of the window frame that secure the switch in place.
 - c. Locate the window assembly in the window opening.
 - d. Locate the plunger switch and install the four mounting screws on the bottom of the window frame that secure the switch in place.
 - e. Insert the window mounting cover plates each side of the window assembly. Install the mounting screws in the cover plates and tighten.
 - f. Verify the window buzzer operation.
2. Vertically Hinged Kick-out Windows
 - a. Locate and connect the wire lead to the switch assembly on the vertical window frame.
 - b. Locate the plunger switch and install the four mounting screws on the side of the window frame that secure the switch in place.
 - c. Locate the window assembly in the window opening.
 - d. Insert the window mounting cover plates each side of the window assembly. Install the mounting screws in the cover plates and tighten.
 - e. Verify the window buzzer operation.

Emergency Exit Doors and Latches

If the emergency door latch has been removed or replaced use the following procedure to install door latches:

1. Locate the interior door latch mechanism and install on door structure.
2. Align the four mounting screws on the door latch assembly with mounting holes on the interior door panel.
3. Locate the exterior door handle mounting plate on the exterior of the door handle panel. Install the two mounting screws to secure the mounting bracket.
4. Install the exterior door handle assembly on the mechanism rod.
5. Locate and tighten the torque head screws at the top of the handle and the other set screw (torque head) on the side of the handle stem.
6. Check the mechanism latch for proper operation and ensure the lock mechanism is lubricated.
7. With the ignition in the "ON" position, check the door buzzer for proper alignment and operation.

Emergency Roof Hatch Exit Install

If the roof hatch has been removed due to external damage and is being replaced, it is recommended that only OEM replacement parts be used in the installation procedure.



WARNING – To avoid personal injury or death always use a secure scaffold assembly and safety restraints or equivalent equipment when servicing the bus roof panels or roof component accessories. An assistant should be present during any roof or roof accessory repair procedures.

1. Locate the replacement roof escape hatch over the roof opening and align the mounting holes in the hatch assembly with the mounting holes in the roof.
2. Apply adhesive or sealer under the perimeter of the hatch assembly prior to fastening the hatch to the roof.
3. Use 1/4" diameter replacement rivets of suitable length. Use a rivet gun of industrial quality to properly set rivets.
4. Install a pliable sealant around the outside perimeter of the hatch to prevent possible leakage.
5. Install the plastic fastener protective caps over the rivets.
6. From inside the bus, locate the hatch buzzer wire harness and connect to the body harness plug.
7. Locate the inside hatch trim ring into the hatch opening in the ceiling. Align the trim ring mounting holes with the existing ceiling panel mounting holes.
8. Insert the mounting screws through the hatch trim ring and tighten.
9. Install the screw cap covers on the interior trim ring.
10. Close the hatch assembly, turn ignition key to the "ON" position and open hatch to verify the alarm operation.

WheelChair Access Door (Optional)

The wheelchair access door is mounted to the bus body structure with three 180 degree swing hinges.

NOTE – An assistant may be required to locate the wheel chair access door in the door opening.

1. Locate the door assembly in the door opening with the hinges mounted on the door assembly.
2. Align the hinge mounting holes with the body mounting holes.
3. Insert the mounting bolts in the hinge assemblies, tighten and swing door to check alignment.
4. If the door seats properly, torque hinge mounting bolts.
5. Open the door and check the door ajar alarm alignment.

6. Close the door assembly, turn ignition key to the "ON" position and open the door to verify the alarm operation.

Wheelchair Lift

The wheelchair lift is a specialized accessory and only a trained technician should attempt the installation of the wheelchair lift assembly. Refer to the manufacturer service manual for installation and servicing procedures.

Wheelchair Floor Plates

Locate the wheelchair plates on the floor where desired. Check all dimensions relative to the placement of the wheelchair and related components.

1. Mark the wheelchair mounting plate holes on the floor. Drill the holes to proper size.
2. Install the four carriage bolts per plate as required.
3. With an assistant locate the mounting bolts from underneath the bus body, install the washers and lock nuts.
4. Tighten lock nuts with torque wrench to the required torque value.

Wheelchair Seat Belts and Shoulder Harness

Locate the seat belt harness track mounting holes above the window assemblies.

1. Align the track mounting holes with the window header mounting and ceiling panel holes.
2. Insert the torque head mounting screws and tighten to the required torque value.
3. Locate the wall mounted shoulder / seat belt storage bag mounting holes in the lower interior side sheet.
4. Install the six mounting screws and tighten.

Emergency Door Glass Protection Screen (Optional)

Locate the emergency door protection screen and place over the lower glass panel.

1. Set the screen in the lower clips center on the window opening. Rotate the remaining clips around to capture the screen frame.
2. Tighten the mounting clips.
3. Align the clips on the screen and tighten the mounting screws.

Emergency Door and Wheelchair Access Door Glass Install

This procedure is for all stationary glass panels excluding the windshield assembly. This includes passenger entry doors, emergency exit doors, wheelchair access doors and destination board lighted glass panel.

Follow the procedure below to install the stationary glass panels.

The procedure for installation of the stationary glass panels includes passenger entry doors, wheelchair lift access door and rear or side emergency exit doors.

To ease installation, the rubber gasket can be heated with a non-flame source (heat gun). At high temperatures, the rubber gasket is more pliable. Do not heat above 125 deg. F for longer than 1 1/2 hours.

1. For smaller glass applications, install the glass in the window seal and set on the lower flange.
2. Utilizing the hook end of the glass installation tool work the seal and glass into the opening.

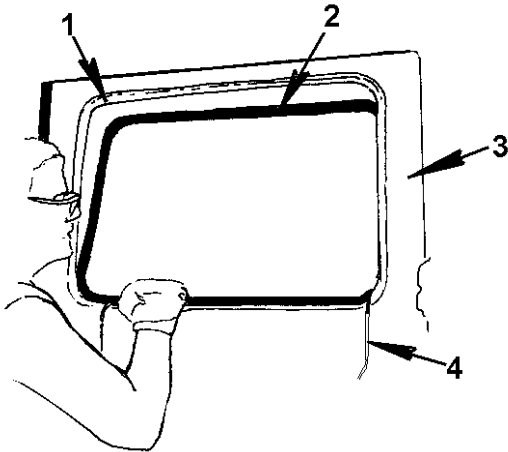

Figure 194 Emergency Exit Door and Wheelchair Door Glass Replace

1. DOOR WINDOW FRAME EDGE
2. GLASS INSERT WITH "H" SEAL
3. DOOR ASSEMBLY
4. WINDOW INSTALLATION ROPE TOOL

3. A foam type glass cleaner or soapy fluid can be used to lubricate the rubber gasket. This will ease the installation of the window and seal.
4. To install the lock lace into the window seal use a lacing tool (# 201-1127) by Sommer Maca. Thread lace rubber through tool into the window seal.
5. Push or pull the rubber around the rubber gasket, feeding the lace rubber into the tool using a hitching motion. This will help prevent the lace rubber from stretching.
6. Inspect the installation and clean off the surface of the glass.
7. Seal the rubber gasket and glass with a pliable windshield sealant.

Safety Equipment (Required)

Road reflective triangles and storage box are a safety requirement on all busses. These are generally stored in a plastic case mounted directly behind the driver position on the crash barrier bulkhead.

1. Locate the reflector mounting case bracket on the lower frame of the driver crash barrier bulkhead.
2. Align the mounting holes in the mounting bracket with the mounting holes in the barrier lower frame.

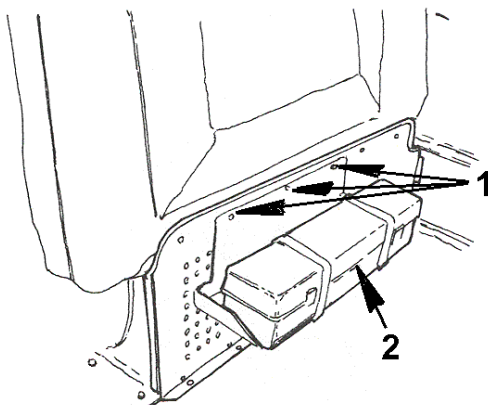

Figure 195 Road Hazard Triangle Mounting Bracket

1. BRACKET MOUNTING SCREWS
2. ROAD HAZARD TRIANGLE CASE

3. Insert the mounting screws through the bracket into the barrier frame.
4. Tighten the bracket mounting screw.

Exterior Light Monitor (Optional)

Locate and position the exterior light check module. Connect the harness connections as may be required.

1. Align the monitor mounting holes with the mounting holes located in the driver bulkhead.
2. Insert the mounting screws and tighten.

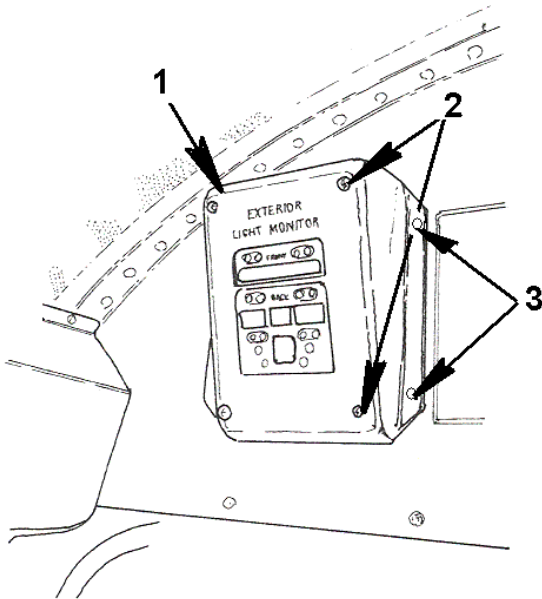

Figure 196 External Light Monitor Mounting

1. EXTERNAL LIGHT CHECK MONITOR ASSEMBLY
2. LIGHT MONITOR COVER SCREWS
3. LIGHT MONITOR MOUNTING HOLES

3. Turn ignition switch to the “ON” position, and check the light monitor for full function.
4. If the monitor works properly, torque the mounting screws to required torque values.
5. If the monitor does not function properly, remove and check harness connections.
6. Re-install the monitor assembly and torque mounting screws.

Fuel Sender Access Panel

To replace center aisle fuel sender access panel, follow procedure below.

1. Place the fuel access panel over the opening in the center aisle floor.
2. Align the holes in the access plate with the holes in the center aisle flooring and insert the mounting screws in the access panel.
3. Tighten all the screws around the access panel. Ensure that no sharp edges are protruding upward that might cause any kind of obstacle in the aisle way.

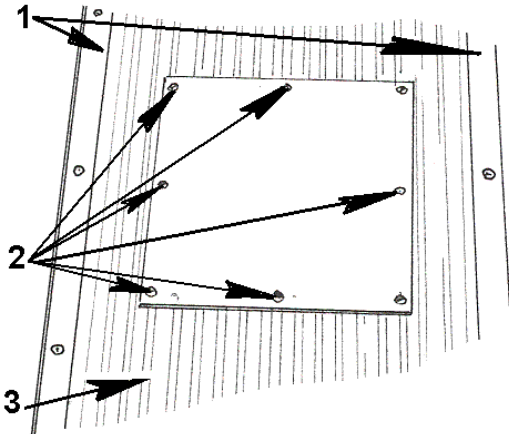

Figure 197 Fuel Sender Access Panel

1. CENTER AISLE TRIM
 2. ACCESS PANEL MOUNTING HOLES
 3. CENTER AISLE FLOOR RUNNER
4. With the access panel under a passenger seat, the seat should have already been removed during the access panel removal procedure.
 5. Follow the same procedure as in steps 3 and 4.
 6. With an assistant locate the seat removed, align the chair rail mounting holes with the mounting holes on the chair bracket. Insert the mounting bolts, nuts and washers through the chair bracket and chair rail. Hand tighten.
 7. With an assistant under the bus floor, locate the mounting foot holes in the chair and align with the mounting holes in the bus floor.
 8. Insert the mounting bolts and the assistant will install the washers and lock nuts. Tighten the chair mounting bolts and nuts to the proper torque value.
 9. Torque the chair rail mounting hardware to the required torque value.

Flooring

If an area of the bus floor is to be replaced, measure the area using the removed piece as a template.

1. Prior to installing the flooring adhesive, make sure the floor and or sub- floor is clean and free of any debris.
2. Replace the flooring that was removed with the new cut to fit piece.
3. Using a floor rolling tool, roll the surface of the flooring in a continuous motion, covering the entire area replaced and including the seams. Let the flooring set up.
4. If the floor was replaced under a row of seats, locate the chair rail holes of the seat and mark the floor accordingly.
5. Drill the flooring at the marks made and install the mounting bolts.

6. If the entire floor area must be replaced all seats must be removed and the sub-floor checked for damage if applicable.
7. If the sub floor requires replacement, remove the sub-floor prior to installation of the new sub-floor. Plug all holes in the floor structure.
8. Seal the floor structure and place adhesive. Place the new sub-floor plywood and screw into place.
9. Follow the same procedure installing the floor covering as was done in the repair procedure.
10. Re-drill the floor seat mounting holes.
11. Install the seats and torque all hardware as required.
12. Torque all fasteners from beneath the bus. All protruding screws and mounting bolts should be coated to prevent corrosion and/or leaks.

5. MAINTENANCE

5.1. HEATERS AND ACCESSORIES

All heating systems used in the vehicles are hot water type. This type system depends on the vehicle's engine to generate heat from the engine coolant or antifreeze. The engine coolant is pumped through the heater hoses, then to the heaters. The primary heating system is plumbed in a "series water flow" system. In this type of system, the heater coolant supply hose is routed to each heater and returns to the engine after exiting the last heater in the system.

Heaters are made up of tube and fin type coils. When the coolant flows through the coils, the blowers move air across the fins of the coil and pick up the heat from the coolant.

This section is for the repair and maintenance of the bus interior heaters. It is advised that caution be taken during any repairs or maintenance to the heater system and that the recommended procedures as defined in the manufacturer's instruction manual be followed.

Driver Side Heater

The driver side heater unit is located directly to the left of the driver position, and below the left wing switch panel and driver storage compartment.

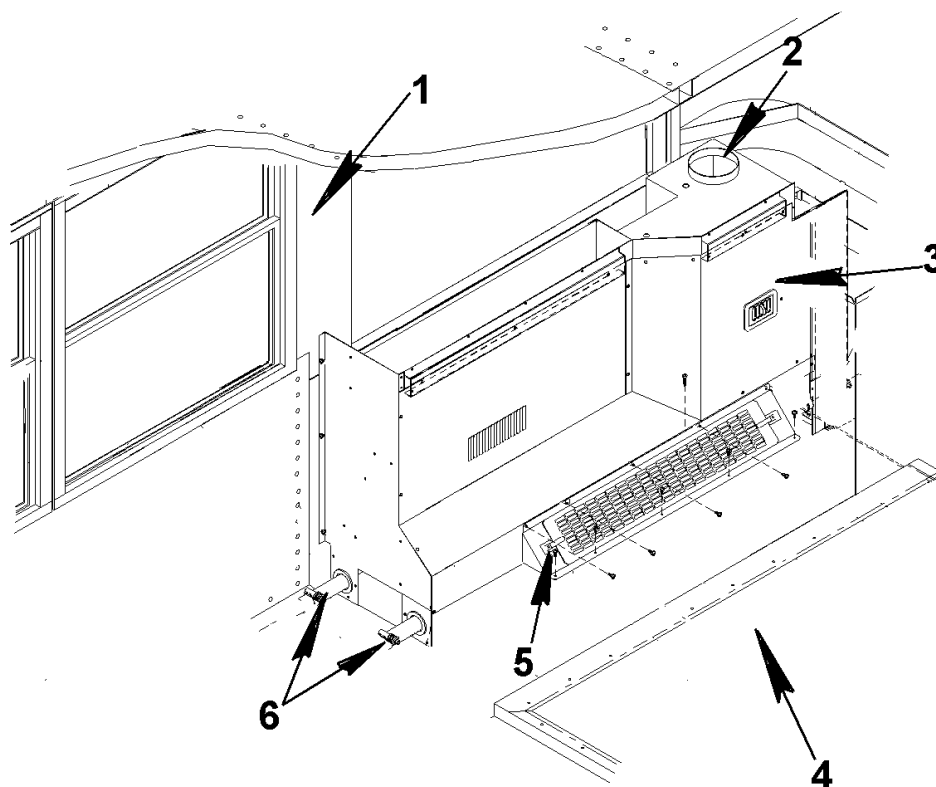

Figure 198 Driver Side Heater Main Heater Assembly

1. DRIVER "B" PILLAR
2. DEFROSTER DUCT CONNECTION FEEDER
3. HEATER FACE ASSEMBLY
4. DRIVER PLATFORM
5. HEATER FILTER PANEL
6. AUXILIARY HEATER FEED LINES

Step Well Heater (Optional)

The optional step well heater is located at the bus entry step well and is controlled from the driver environmental and climate control panel located between the driver side storage compartment and the driver's left wing switch panel.

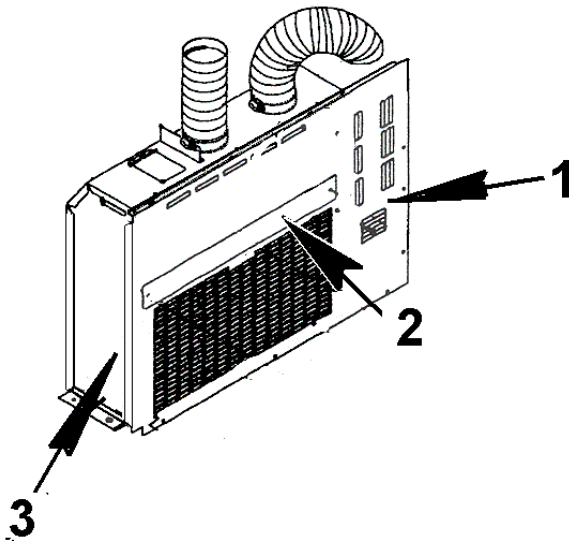

Figure 199 Step Well Heater (Optional)

1. STEP WELL HEATER FACE PLATE
2. FILTER ACCESS PANEL
3. STEP WELL HEATER ASSEMBLY

Under Seat Heaters

The under seat heaters are located along the driver side of the bus in various locations depending on the length of the bus body. The heaters are located under a passenger seat and protected by a screened cover to protect them from damage.

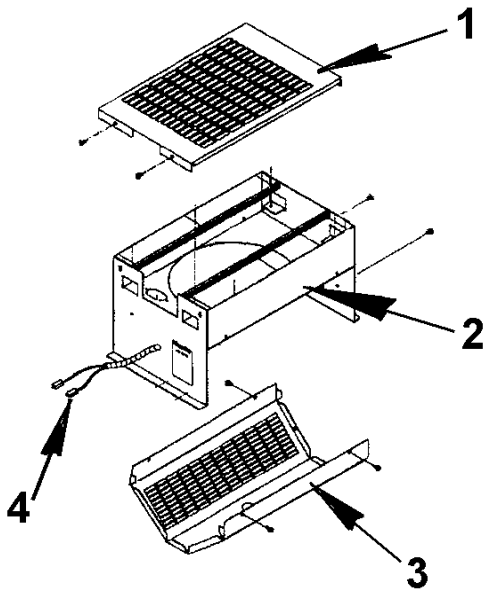

Figure 200 Under Seat Heater

1. AUXILIARY UNDER SEAT HEATER COVER PLATE
2. UNDER SEAT HEATER BODY ASSEMBLY
3. UNDER SEAT HEATER LOWER COVER AND AIR INLET
4. 12 VOLT DC HEATER HARNESS CONNECTOR

Rear Body Heaters (Optional)

Rear body optional heaters are generally used in conjunction with wheelchair access doors.

Maintenance

It is recommended that the heating system be inspected annually. However, more critical areas, such as around the engine, should be inspected on a regular basis. Filters should be removed and cleaned regularly.

Heaters and Accessories

1. Heater Coils

- a. The heater coils are most efficient when the coils, fins and air flow passages are kept clean and free of dirt and dust. The coils should be cleaned with a soft flow compressed dry air or vacuum and a soft brush. Damaged fins should be straightened to prevent air flow restrictions.

2. Hoses

- a. All heater hoses should be inspected for kinks and chafing that will cause failure. Hoses should be replaced when cracks or permanent distortions are found.
- b. Hoses and clamps should be checked regularly. Hoses may appear in good condition on the outside, but the inside may be partially deteriorated. If there are any doubts about the condition of the hoses, replacements should be made. Clamps should be inspected to ensure they are strong enough to hold a tight connection.

3. Motors/Switches/Blowers and Fans

- a. Motors are essentially maintenance free and do not require any lubrication or cleaning. However, excessive vibration caused by damaged blowers, wheels, and fans can cause motor damage.
- b. Switches are maintenance free, but can be damaged by water and loose wire connections. Loose wires cause the component to require more amperage than normal. Inspect on a regular basis.
- c. Defroster fans can be mounted on the bulkhead above the driver. The fans should be kept clean of dirt and dust. The metal cage can be removed for blade cleaning. Bend the metal lock clamps to remove the metal cage.

4. Antifreeze

- a. The antifreeze mixture of the coolant system is a 50/50 mixture of antifreeze and water. The mixture will protect the unit to -40 degrees F. For added protection in colder climates, refer to the engine coolant section.

Troubleshooting

Typically when a school bus does not have heat or air flow, several steps should be taken to eliminate the problem. Use the steps below as a problem solving guide.



WARNING – Use the following procedure to remove the pressure-type cap from the radiator. Always allow the engine to cool first. Wrap a thick, heavy cloth around the cap. Push down, loosen cap slowly to the first notch position; then pause a moment. This will prevent possible scalding by hot steam or water, which can cause injury and/or property damage.

1. No Heat from the Engine

- a. Check the heater hose gate valves. Make sure they are open (supply and return).

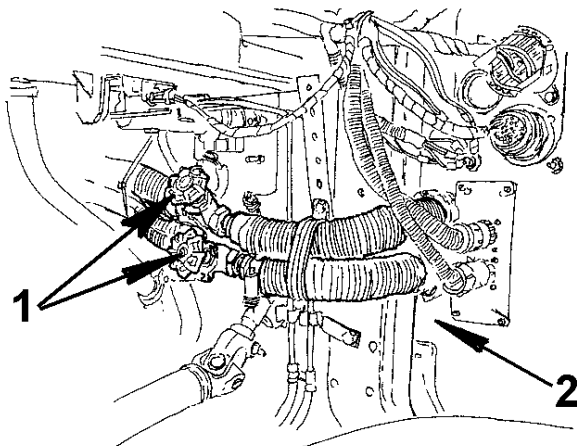

Figure 201 Heater Hose Gate Valves

1. HEATER HOSE SHUT OFF VALVES
2. DRIVER SIDE COWL ASSEMBLY

- b. Check the coolant level. Make sure the coolant system is full and flowing.
- c. Touch the heater hoses and feel for heat at the engine supply hose.
- d. Inspect the heater hose routing for kinked hose that could block coolant flow.
- e. Make sure the booster pump is operating correctly if present.
- f. Open the bleeder valve and check for air in the heater hose (air lock).
- g. Check engine operating temperature gauge and compare to air flow from heaters.
- h. Check the butterfly valve and actuating cable for proper operation.

2. No Air Flow from Heater Vents or Ducts

- a. Check the circuit breaker or fuse.
- b. Check the switch.
- c. Check the blower motor.
- d. Check the resistor.
- e. Check the harness connections for an open circuit.
- f. Repair any items that are not functioning as required.

Heater / Defroster and Blower Motor Access Procedures

Each blower assembly has a resistor that controls the speed of the rotor. The defroster / step switch is a three-speed switch with a three-post resistor. When checking for speed variation, check all three speeds. Use a multi-meter to check the resistor. Refer to the IC Bus Troubleshooting Guide.

Access Main Front Heater / Defroster Blower Motors and Resistors Assembly

To access the driver / main heater assemblies use the following steps:

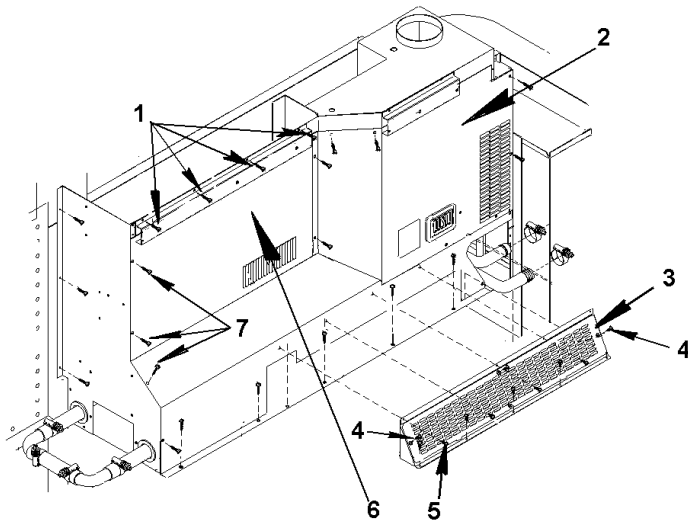

Figure 202 Access Main Front Heater

1. LEFT HAND SWITCH PANEL COVER MOUNTING SCREWS
2. HEATER PANEL ACCESS COVER
3. HEATER FILTER COVER PANEL
4. FILTER COVER MOUNTING SCREWS
5. FILTER COVER BASE MOUNTING SCREWS
6. HEATER BOX COVER PANEL

1. Drivers Heater Filter

- a. Locate all surface mounting screws at base of drivers heater panel (Fig. 202, Items 4 and 5).
- b. Loosen and remove the filter cover mounting screws.
- c. Lift filter cover panel away from heater assembly.
- d. Remove filter.

Auxiliary / Midship Heater Motor Access

To gain access the auxiliary heater motor or resistors, use the following steps.

1. The auxiliary and/or midship heaters may vary in location. The rear auxiliary heaters when used with the wheelchair access door may be a vertically wall mounted assembly. The under seat heaters will be mounted under the standard passenger seat assembly. Depending on the type service the seat may or may not require removal.
 - a. Locate the passenger seat above the heater assembly.
 - b. Flip the seat cushion up by adjusting the seat clip.
 - c. Remove the heater cover (Fig. 200, Item 1) panel mounting screws.

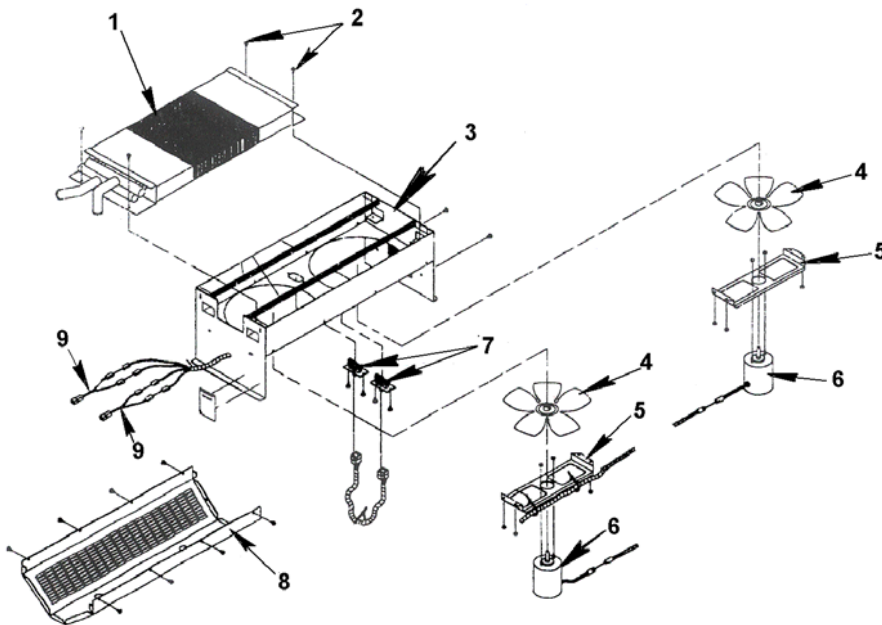

Figure 203 Under Seat Heater Motor Access (84,500 BTU SHOWN)

1. HEATER COIL
2. HEATER COIL MOUNTING SCREWS
3. UNDER SEAT HEATER BODY ASSEMBLY
4. FAN
5. FAN MOTOR MOUNT
6. MOTOR
7. RESISTOR
8. BOTTOM HEATER COVER
9. HARNESS

- d. Remove the screws that secure the heater to the floor.
- e. Remove the heater panels upper and lower, exposing the internal parts.
- f. Locate the heater motor and disconnect the wire leads from the resistor.
- g. Remove the motor casing nuts that secure the motor to the shroud.
- h. Remove the fan from the motor shaft by using a small Allen wrench and turning the set screw counter-clockwise.
- i. Remove the fan motor.

Optional Step Well Heater Assembly

To access the step well heater assembly, check for optional components that may be existing and have to be removed to gain access to the step well heater.

1. Filter Remove

To remove, clean or change step well heater filter use the following procedure.

- a. Locate the 3 filter plate mounting screws.

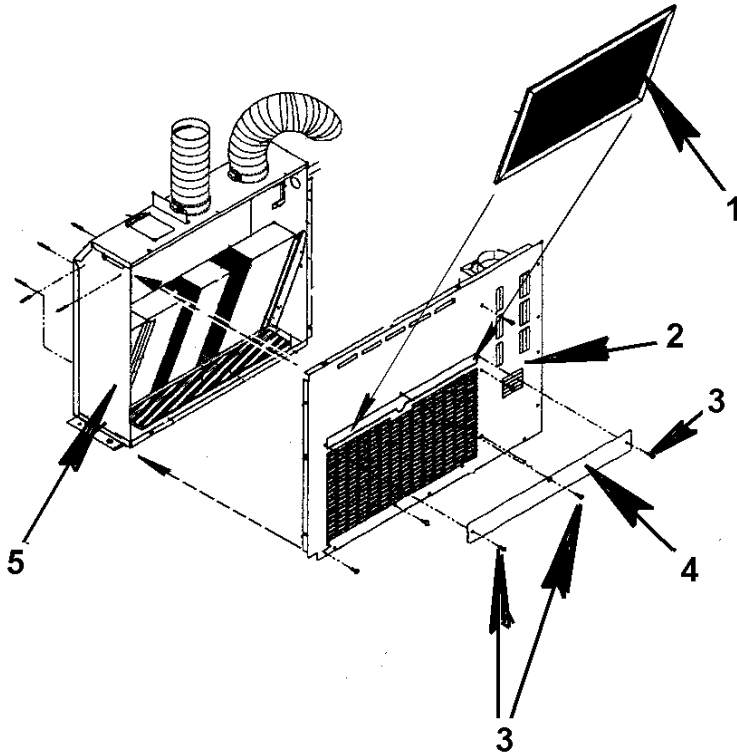

Figure 204 Filter Remove

1. STEP WELL HEATER FILTER ASSEMBLY
2. STEP WELL HEATER FACE PLATE
3. FILTER COVER PLATE MOUNTING SCREWS
4. FILTER COVER PLATE
5. HEATER FACE PLATE MOUNTING SCREWS

1. Loosen and remove mounting screws.
2. Remove the filter cover plate.
3. Remove the filter assembly.
4. To install filter reverse steps 1 through 3.

b. Remove Step Well Heater Blower Assembly

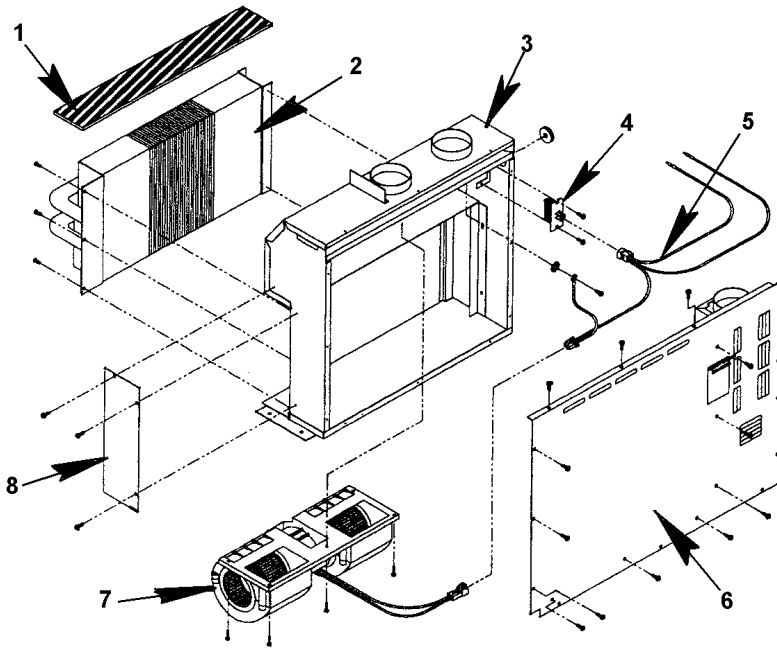

Figure 205 Step Well Blower Motor Assembly

1. URETHANE INSULATOR
2. HEATER COIL
3. HEAT BODY ASSEMBLY
4. RESISTOR
5. WIRE HARNESS
6. STEP WELL HEATER FACE PANEL
7. DUAL WHEEL BLOWER
8. HEATER COIL SIDE COVER PLATE

1. Remove the optional assist handrail (if applicable).
2. Remove the fire extinguisher and mounting bracket (if applicable).
3. Remove the mounting screws along the lower edge of passenger entry dash panel.
4. Loosen and remove the mounting screws on face plate (cover weldment).
5. Loosen and remove the defroster hose clamps attaching defroster hose to front face plate.
6. Disconnect the harness plug connection to dual wheel blower assembly (if blower is to be removed).
7. Loosen and remove the five dual wheel blower mounting screws attaching the blower assembly to the case weldment. Remove the dual wheel blower assembly.

c. Heater Coil Removal

The supply lines to and from the step well heater coil should be closed, prior to removal procedure.

Follow the procedures above to access the heater coil. To remove the heater coil:

1. Locate the four mounting screws on the coil assembly bracket. Loosen and remove the mounting screws.

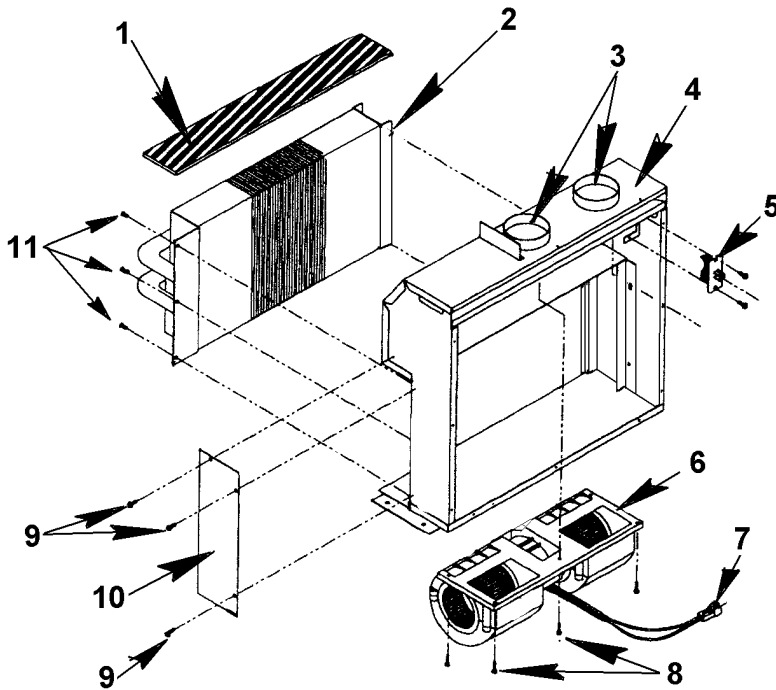

Figure 206 Heater Coil Removal

1. POLY URETHANE INSULATOR
2. HEATER COIL
3. DEFROSTER DUCT MOUNTING RINGS
4. STEP WELL HEATER BODY ASSEMBLY
5. RESISTOR
6. DUAL BLOWER MOTOR ASSEMBLY
7. BLOWER HARNESS CONNECTION
8. BLOWER ASSEMBLY MOUNTING SCREWS
9. HEATER COIL SIDE COVER PLATE MOUNTING SCREWS
10. HEATER COIL SIDE COVER PLATE
11. HEATER COIL MOUNTING SCREWS

2. Partially remove the heater coil assembly to gain access to the hose clamp connection to the supply and return lines.
3. Remove the coil gasket.
4. Remove the heater coil.

Troubleshooting Chart

Table 1 Heater Troubleshooting

Application	Troubleshooting Suggestion
Hose not warm to the touch.	Check heater cut-off valves (open) to make sure they are open. Check the butterfly valve for proper operation.

Table 1 Heater Troubleshooting (cont.)

Cold air flow from heaters.	Check coolant level and hoses for indications of coolant flow. Check for kinks and air blockage.
No air flow from heater.	Check blower and motor switch.
Blower motor has one speed only.	Check wiring and switch connection.
Poor water circulation.	Check booster pump and hose routing.
Air in the heater hose system.	Remove the surge tank cap, fill tank, start engine, open valves, bleed heater at bleeder valve.

Fluid Capacity**Table 2 Fluid Capacity**

Application	Volume / Cu .In.
Main Heater	84.35
Driver Heater	71.46
Auxiliary 1 Fan	47.31
Auxiliary 2 Fan	91.69
Heater Hose 1 Ft.	.17

Upholstery Care and Cleaning Recommendations

The upholstery vendor has supplied a list of solvents that are safe to use when cleaning the upholstery. These solvents, if properly used, will not harm the finish of the material. These solvents include:

- Denatured Ethyl Alcohol
- VM&P Naphtha
- Odorless Mineral Spirits
- Isopropyl Alcohol

Recommended Cleaning Instructions

1. Wash with mild soap and hot water to remove ordinary dirt, grime, etc.
2. Stubborn stains should be cleaned with alcohol. Odorless Mineral Spirits or VM&P Naphtha can be used to remove paint, tar, gum, shoe polish, etc. if alcohol does not remove the stain.
3. Isopropyl Alcohol and Denatured Alcohol are especially recommended for cleaning stubborn dirt and stains.
4. Never clean upholstery with polish remover, Graffiti Eater strong caustic or acidic agents or any cleaners with active solvents like MEK, Tolual, gasoline, etc.

6. EXTERIOR BODY REPAIR

NOTE – Before repairing body construction, consult your local distributor for OEM parts and additional information, if required. This procedure is only a general procedure for typical body side panel repairs. Extreme care should be used in performing body repairs. The repair should only be done by trained technicians.

6.1. REMOVE

Fasteners

The fasteners utilized in the manufacture and assembly of the bus body are mechanical type fasteners. Each joint is designed in a manner that it is imperative to replace all body panels and fasteners with OEM equipment. All body panels are required to meet federal standard F.M.V.S.S. 221. This standard establishes that all body panels must meet 60% joint strength requirements. Because of this standard and International design, it is very difficult to remove certain body panels. The following procedure will describe what is required to replace damaged body panels, in most conditions. Only trained technicians should perform the repair work.

1. Remove all rivets from the damaged panels.
2. Center punch all rivets in preparation for removal. This is important in order to prevent damage to panels that over- or underlap damaged panels.
3. Utilizing a heavy duty reversible drill and 17/64" diameter drill bit, drill through the rivet head until rivet sleeve separates from the rivet head.

Body Panel Remove

1. Remove all rivets from the damaged body panel. The rivets may be removed by using a large chisel and a #10 drill bit.
2. With the head or cap of rivet removed, use drill to remove sleeve of the rivet out of the body panel.
3. With rivets and sleeves removed from body panel, check panel overlap. New body panels must be installed with same panel overlap as that of removed panel.
4. Removal of some panels may require removal of body rub rails, depending on the location of the damage.
5. If rub rails are to be removed, follow procedure for removing rivets.

End Cap Remove

When removing the front end cap, the exterior rear view mirrors and any electrical connections for mirrors must be removed.

1. See mirror removal section of this manual for removal of exterior rear view mirrors.
2. The windshield and side panels must also be removed prior to removing end cap rivets. (Refer to windshield removal.)
3. Following rivet removal procedure, remove as many rivets from end cap drip rail as needed to free front end cap for removal.

6.2. INSTALL

NOTE – Instructional and warning decals must be re-installed on emergency doors, windows, etc. when repairs are performed.

Rivet Replacement

1. Use 1/4" diameter replacement rivets of suitable length.
2. An industrial quality rivet gun is recommended to properly set rivets.
3. Install the rivets as required.
4. Seal all overlapped joint seals with yellow sealer. Allow to dry before painting.

Body Panel — Install

NOTE – Replacement panels are not pre-punched. Drilling may be required for rivet installation and alignment.

Install the replacement panel with the overlap in the same direction of the panel that was previously removed.

1. Position the panel in the same location as the original part.
2. Use a heavy duty reversible drill and #10 drill bit to ream out rivet holes in the replacement panel.
3. Insert #12 screws to secure panel in position until all rivet holes are drilled for rivets.
4. Install 3/16" HUCK MAGNA LOCK pop rivet.
5. Seal all overlapped joint seals with yellow sealer. Allow sealer to dry before painting.

End Cap Replacement

The end caps on the front and rear of the bus body are replaceable. Care should be taken in the process or removal and installation of the assemblies.



WARNING – To avoid personal injury or death always use a secured scaffold assembly and safety restraint when servicing the bus roof panels or roof component accessories. An assistant should be present during any roof or roof accessory repair procedures.

NOTE – When replacing end caps, some interior panels are required to be removed to drill pilot holes through the roof bows, for the end cap attachment process.

When replacing the front cap assembly, the driver bulkhead compartment and any equipment mounted on it will have to be removed to access the roof bow assembly.

This includes:

- Optional defroster fan assemblies.
- First aid kits and Body fluid clean-up kits.

- Driver interior rear view mirror and sun visor (if applicable).
 - Exterior light check system (if applicable).
 - The forward ceiling panel or rear depending on end cap being replaced.
 - Any other items that may be options that would be mounted on the driver overhead bulkhead.
1. With the applicable interior items removed, mount the forward end cap on the roof assembly and header assembly.
 2. Insert bolts in the lower forward edge and corners of the end cap assembly. Check the fit and alignment with the roof panels.
 3. From the inside front section of the bus, drill through the roof bow and roof panel holes, through the end cap assembly.
 4. With the roof bow holes drilled, prior to installing pilot rivets, install sealer adhesive along the existing roof panel and under the rear edge of the end cap.
 5. Install pilot rivets across roof bow to ensure alignment.
 6. Beginning at the front corner over the windshield install rivets through the new end cap into header assembly and side section over driver window frame and entry door frame.
 7. Insert the remainder of roof bow rivets as required. Check joint seals at end cap and front roof panel.
 8. If end cap seats properly, re-install interior bulkheads, and equipment that may have been removed.
 9. Re-install the front windshield assembly (see windshield installation).
 10. Install the end cap marker light and connect marker light harness plugs.
 11. Seal all seams prior to paint.
 12. If bus is equipped with glass destination board, install the glass panel and seal.

7. WINDSHIELD WIPER DRIVE SYSTEM

7.1. WINDSHIELD WIPER MOTOR— REMOVE

This section covers the servicing, removal and installation of the windshield wiper system. The windshield wiper system is a single motor dual drive wiper system. The windshield wiper motor is located under the defroster duct, and mounted to the cross bus beam assembly. To remove the wiper motor assembly, the windshield wipers must be removed from the drive arms. See windshield wiper section in this manual.

1. Locate the windshield wiper arm assembly to be removed and swing the wiper arm out at the swivel assembly.
2. Disconnect the windshield wiper fluid supply line from the connector at the wiper arm base.
3. Remove the plastic cap assembly covering the wiper arm attachment nut.
4. Loosen and remove the attachment nut.

5. Make a mark on the wiper arm assembly with a coinciding mark on the wiper drive stud. This will help in the re-alignment when re-installing the wiper arm on the drive.
6. Locate the bushing and jam nut behind wiper arm mounting, loosen and remove.
7. Follow the same procedure to remove the opposite side wiper drive arm.

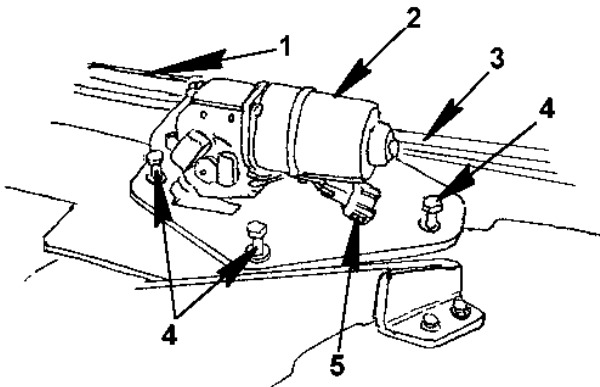

Figure 207 Windshield Wiper Motor Remove

1. DRIVER SIDE WINDSHIELD WIPER DRIVE ARM
 2. WINDSHIELD WIPER MOTOR
 3. PASSENGER SIDE WINDSHIELD WIPER DRIVE ARM
 4. WINDSHIELD WIPER MOTOR ASSEMBLY MOUNTING BOLTS
 5. WIPER MOTOR HARNESS CONNECTION
8. Proceed to interior of bus body and follow dash board panel removal procedures. Reference Dash Board Panels, Cluster and Switch Panel removal.
 9. If the bus is equipped with a step well heater, remove the face plate, disconnect the defroster hose connection clamp to allow clearance for duct repositioning.
 10. When the dash panels covers and step well heater face plate (if equipped) are removed reposition the passenger end of defroster duct. Lift duct upward and support to get access to wiper motor and mounting assembly.
 11. Locate the wiper motor harness plug assembly and disconnect from cab harness section.

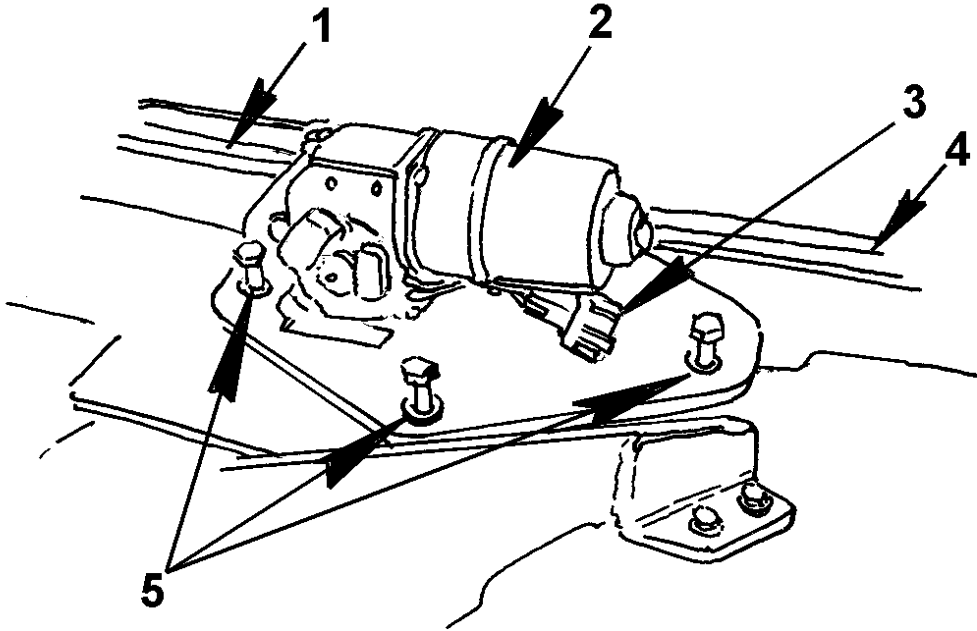

Figure 208 Windshield Wiper Drive Assembly

1. DRIVER SIDE WINDSHIELD WIPER DRIVE ARM
2. WINDSHIELD WIPER MOTOR
3. WINDSHIELD WIPER MOTOR HARNESS CONNECTOR
4. PASSENGER SIDE WINDSHIELD WIPER DRIVE ARM
5. WINDSHIELD WIPER MOTOR MOUNTING BOLTS

12. Locate the windshield drive arm lock nut and washer on the drive stud on the front side of the wiper motor.
13. Loosen and remove the nut and washers, slide the drive arms off the stud.
14. Locate the mounting nut on the wiper motor drive stud securing the wiper drive arms to the wiper motor assembly.
15. Loosen and remove the drive arm mounting nuts, and washers.
16. Locate the three wiper motor mounting bolts, nuts and washers securing the motor to the mounting plate.
17. Loosen and remove the bolts, nuts and washers.
18. Remove the wiper motor.
19. Follow the reverse procedure to install the wiper motor, drive arms and wipers.

8. PAINT AND FINISH

This procedure is for the touch up and painting for National School Bus Yellow Urethane Paint.

8.1. TOUCH UP AND PAINT PROCEDURE

1. Surface cleaning and preparation.
 - a. All dirt, grease, oils, sealants or any contaminants must be removed.
 - b. Surface should be washed. Solvent wash is recommended.
 - c. Surface area must be scuff sanded with fine finishing grade sandpaper until gloss is removed.
 1. On final sanding operation, 400 grit or finer sandpaper is recommended.
 - d. Surface area must be clean of all sanding dust and other particulates.
 1. Tach cloth wipe of area is recommended.

2. Metal Preparation and Prime

All bare metal areas are to be treated/conditioned and then primed. Use a metal treatment/conditioner. Apply a coat of good quality, two-component epoxy primer before applying topcoat. Primer should be an automotive grade.

3. Topcoat

KAY0015 / CT0066 needs to be mixed at a ratio of four (4) parts paint (KAY0015) to one (1) part catalyst (CTC00660) by volume.

Products are to be mixed thoroughly.

Paint can be reduced with a maximum of 2.5 ounces BCA solvent per quart. Add the BCA solvent to the KAY0015 part before mixing with the CTC0066.

This product has a "pot life" of fifteen minutes at 77 degrees F after being mixed together. Product should be used within this time.

Product, when mixed properly, will "cure to tape" in two hours with maximum hardness being achieved in three to five days with no external heat source.

9. LETTERING AND DECALS

This section covers the proper installation of lettering and decals to the school bus.

9.1. SURFACE PREPARATION

1. Surface Preparation

All surfaces must be considered dirty and must be cleaned prior to the application of markings. Recommended cleaning procedures for specific surfaces are listed below.

- a. Plastic and Glass

1. Saturate a clean cloth with a two to one mixture of water and isopropyl alcohol and wipe the surface (cleaners such as Windex may be used). Wipe the surface dry with a clean, dry, lint free cloth.

- b. Painted Metals and Base Metals

1. These surfaces must be cleaned with solvent such as E.I. DuPont PreSol Cleaning Solvent 39195, Xylol, VM & P Naptha, or Lacquer Thinner. Dry the surface with a lint free cloth before

the solvent evaporates. Freshly painted surfaces must be dried one week prior to application of a cleaning solvent.

c. Interior Painted Surfaces

1. Paint must be dried one week prior to application of markings. Clean the area where the markings are to be applied with a household cleaner such as 409. Rinse thoroughly and dry.

d. Temperature Requirements

1. Air and application surface temperature must be above 40 degrees F for decals to function properly.

2. Application Instructions

- a. Use 1"- 2" strips of masking tape to position marking in the proper position.

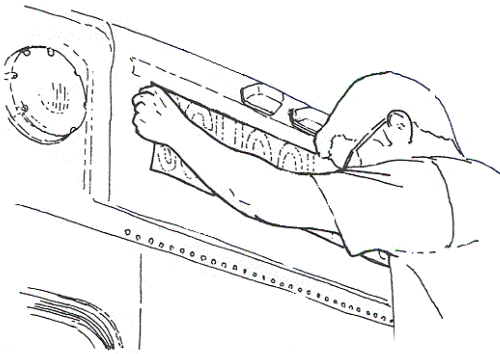

Figure 209 Aligning the Decal

- b. Squeegee masking in place with squeegee pressure.

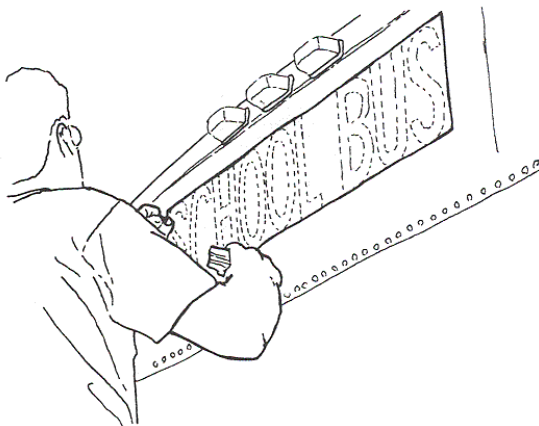

Figure 210 Squeegee Masking

- c. Remove liner entirely and allow marking to drape.

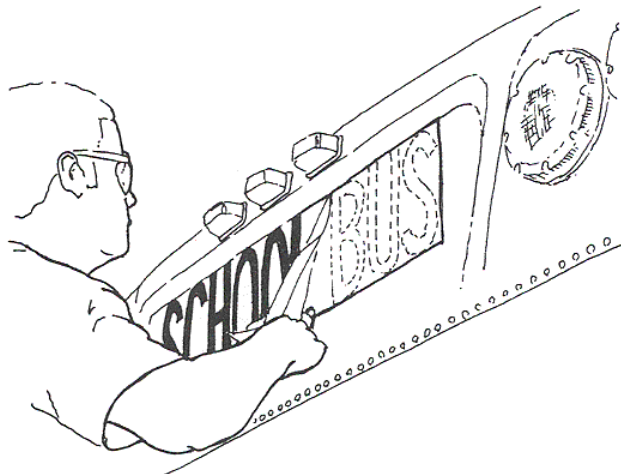

Figure 211 Remove Mask

- d. Using firm initial squeegee pressure, begin at the top center and work down and out to each edge of the mask.

10. CHARTS AND TABLES

10.1. COMPONENT INSPECTION INTERVALS

The following charts and tables are the recommended inspection intervals for the various components to keep the CE 200 and CE 300 in proper working order and maintain a safe operating environment.

Table 3 Component Inspection Intervals

ITEM	INSPECTION INTERVAL					
	DAILY	1 MO. 1,500 MI.	2 MO. 3,000 MI.	4 MO. 6,000 MI.	6 MO. 9,000 MI.	ANNUALLY 12,000 MI.
Body Mounting Bolts		1 st				Thereafter
Windows, Doors and Locks					X	
Hoses, Heaters and Connections		1 st				Thereafter
Chassis Cowl to Body Mounting Bolts						X
All Exterior Lights	X					

Table 3 Component Inspection Intervals (cont.)

Doors, Seals and Switches	X					
Emergency Equipment	X					
Exterior Hinges		X				
Interior Hinges				X		
Floor Covering			X			
Seat Belts and Bolts		1 st		Thereafter		
Emergency Exits	X					
Spare Tire Carrier				X		
Door Control Assembly		X				
Electrical system				X		
Glass / Windows	X					
Wipers and Washer		1 st				
Wheelchair Securement		1 st		Thereafter		
Light Lens	X					
Battery Compartment		1 st				Thereafter
Paint / Exterior				X		
Door Hinges		X				
Heater System						X
All Mirrors	X					
Warning Light System	X					
The preventive schedule above is only a minimum inspection time suggested by I.C. Corporation						

Table 4 Lubrication Recommendations for Locks and Hinges

Lubrication Recommendations for Locks and Hinges		
Application	Lubricant	Schedule
Emergency Door Hinges	Any multi-purpose grease	Every 60 days
Entrance Door Hinges	Light Oil 10–20 wt.	Every 30 days
1 and 3 Point lock Assembly	Lubriplate* wht. grease	Every 60 days
Luggage Box Doors	Lubriplate* wht. grease	Every 60 days
Key Ways and Locks	Graphite- internal	Every 60 days
Electrical Access Door	A-1 Oil-light oil	Every 60 days
Radiator Access Door	A-1 Oil-light oil	Every 60 days
Door Roller Assembly	#2 Multi-purpose lithium	Every 30 days

10.2. TORQUE CHARTS

Table 5 Torque Chart

Item #	Location (Figure No.)	LBF-FT / IN	Nm
6	Wheel Well Cover (Fig. 58)	Do Not Over Tighten	Do Not Over Tighten
3	Emergency Exit Flip Up Seat (Fig. 62)	35–50	47.5–68
4	Exterior Light Monitor Mounting Screws (Fig. 69)	17–23	23–31
2	Passenger Seat Mounting Nuts on Floor Track (Fig. 72)	20–22	27–29.8
3	Shoulder Harness Track Mounting (Fig. 73)	19–20	26–27
1	Shoulder Harness Bag (Fig. 74)	15–30 IN	1.7–3.39
1	Windshield Defroster Fan (Fig. 87)	20–24.5 IN	2.3–2.8
3	Windshield Wiper Mounting Nut (Fig. 92)	16–18	21.7–24
2	Drivers Exterior Rear View Mirror Mounting Screws (Fig. 99)	20–24.7 IN	2.3–2.8
5	Passenger Side Rear View Mirror (Fig. 100)	18–20	24–27
1	Exterior Warning Lights / Stop-Tail Lights (Fig. 101)	Do Not Over Tighten	Do Not Over Tighten
2	Body Side Assist Steps (Fig. 105)	34–38	46–51
1	Fuel Fill Door and Panel (Fig. 108)	4–5	6–7
1 & 2	Emergency Door Exit Hinges (Fig. 111)	18–20	24–27
1 & 2	Rear Bumper Mounting Bolts (Fig. 115 & 116)	100–120	135–162
2	Rear Bumper Mounting Bracket (Fig. 117)	100–120	135–162
1 & 3	Stop Arm Assembly Mounting Screws (Fig. 119 & 120)	8–10	11–13.6
1	Fenderette Mounting Bolts & Nuts (Fig. 121)	8–10	11–13.6
1	"J" Clip Mounting Bolts and Nuts (Fig. 122)	30–45	40.7–61
2	Electrical Compartment Door Mounting Nuts (Fig. 124)	15–30 IN	1.7–3.39
1,4 & 5	Transition Panel Mounting Screws (Fig. 126)	11–13	14.8–18.1
5	Formed Body Tie Down (Fig. 129)	30–40	40.7–54
2	Out Rigger Tension Spring Tie Down (Fig. 130)	30–40	40.7–54
3	Outrigger Frame Mounting Bolts (Fig. 131)	50–55	68–75
3	Step Well Tread Mounting Screws (Fig. 133)	3–4	4–6
1 & 2	Step Well Assist Handrail (Fig. 134)	77–95 IN	8.7–10.7
4	Instrument Panel Mounting Screws (Fig. 138)	15.9–19 IN	1.79 – 2.14
2	Dash Panel Bezel Mounting Screws (Fig. 139)	Do Not Over Tighten	Do Not Over Tighten
3	Instrument Panel Cluster Mounting Screws (Fig. 140)	Do Not Over Tighten	Do Not Over Tighten

Table 5 Torque Chart (cont.)

3	Heater Control Mounting Screws (Fig. 141)	Do Not Over Tighten	Do Not Over Tighten
1	Heater Control Mounting Screws (Fig. 142)	Do Not Over Tighten	Do Not Over Tighten
2	Drivers Storage Bin (Fig. 143)	Do Not Over Tighten	Do Not Over Tighten
1,3 & 5	Drivers Sliding Window Assembly (Fig. 144 & 145)	125–140 IN	14–16
2 & 5	Drivers Shoulder harness Mounting Bolt (Fig. 146)	40–42	54–57
1 & 5	Drivers Seat Lap Belt Mounting Bolts (Fig. 147)	10–12	13.6–16.5
3	Drivers Seat Lap Belt Mounting Nuts (Fig. 147)	40–42	54–57
1 & 7	Crash Barrier Floor Mounting Bolts (Fig. 148)	20–22	27–30
5 & 3	Crash Barrier Chair Rail Mounting Bolts (Fig. 148)	19–24.5	26–33.2
5	Passenger Door Drive arm Attachment Nut (Fig. 151)	15–30 IN	1.7–3.39
4	Passenger Door Drive Mounting Bracket (Fig. 152)	10–12	13.6–16.5
1	Light Bar Mounting Screws (Fig. 154)	Do Not Over Tighten	Do Not Over Tighten
3	Passenger Seat Floor Mounting Bolts & Nuts (Fig. 156)	20–22	27–30
2 & 7	Seat Cushion Fasteners (Fig. 157)	Do Not Over Tighten	Do Not Over Tighten
1	Seat Belt / 2– Point Passenger Mounting Bolts and Nuts (Fig. 159)	20–35	27–47.5
1	Emergency Exit Door Hold Open Device (Fig. 163)	13–15	17.6–20
3	Fuel Sender Access panel Mounting Screws (Fig. 169)	15–30 In	1.7–3.39
1	Windshield Wiper Drive Stud Mounting Nut (Fig. 170)	16–18 IN	1.8–2
3	Vandal Lock Mounting Screw (Fig. 179)	Do Not Over Tighten	Do Not Over Tighten
3 & 5	Wheel Chair Access Door Hinge Mounting Screws (Fig. 181)	13–15	17.6– 20
1	Electric Door Opener limit Switch Mounting Screws (Fig. 187)	Do Not Over Tighten	Do Not Over Tighten
1	Window Assembly Cover Plate Mounting Screws (Fig. 193)	Do Not Over Tighten	Do Not Over Tighten
1	Road Hazard Triangle Bracket Mounting Screws (Fig. 195)	3–3.3	4–4.5
2	Exterior Light Monitor Mounting Screws (Fig. 196)	17–23	23–31
2	Fuel Sender Access panel Mounting Screws (Fig. 197)	15–30 In	1.7–3.39
4	Windshield Motor Mounting Bracket Bolts (Fig. 207)	44.3–62 IN	5–7
5	Windshield Motor Mounting Bracket Bolts (Fig. 208)	44.3–62 IN	5–7