

TCM SERVICE MANUAL



SERVICE MANUAL

FORKLIFT TRUCK

FG20^{T3} - FG30^{T3}, FHG15^{T3} - FHG30^{T3}, FG35^{T3S}
FD20^{T3} - FD30^{T3}, FHD15^{T3}, FHD20^{T3A} - FHD30^{T3A}, FD35^{T3S}

FHD15^{T3}	FHG15^{T3}
FHD18^{T3}	FHG18^{T3}
FD20^{T3}	FG20^{T3}
FHD20^{T3A}	FHG20^{T3}
FD25^{T3}	FG25^{T3}
FHD25^{T3A}	FHG25^{T3}
FD30^{T3}	FG30^{T3}
FHD30^{T3A}	FHG30^{T3}
FD35^{T3S}	FG35^{T3S}

TCM CORPORATION

No. SEF-0F7BE

TCM CORPORATION

FOREWORD

TCM's new forklift trucks with capacities from 1.5 through 3.5 tons feature low operating noise and reduced vibration as well as improved controllability and higher safety, and come equipped with new high-performance engines.

The gasoline engines used for this series are equipped with an electronically-controlled fuel supply unit to reduce emissions from the engine.

The steering system can correct steering wheel knob deviation automatically to provide better driver control. The instrument panel accommodates optional OK monitors which allow the operator to check the water level, air cleaner plugging, and battery condition of charge with just a glance. The serviceability of these trucks has been greatly improved by these changes.

This Service Manual describes all of the major components and their service procedures. We encourage you to make practical use of it while servicing the trucks.

We also hope you will understand that, due to on-going improvements of the parts and components, the values and some of the descriptions in this manual are subject to change without notice.

February 2010



The specifications and equipment covered in this manual will vary according to the intended destination. In our documents and manuals, these differences are coded according to the destination as follows.

Export specification code	Destination
EXA	North America
EXB	All regions excluding North America, EU member countries, Oceania and South Africa
EXC	Oceania
EXE	EU member countries (excluding Scandinavia)
EXK	South Africa
EXN	Scandinavia

SPECIFICATIONS (1)

Item	Truck model	FHG15 ^{FB}	FHD15 ^{FB}	FHG18 ^{FB}	FHD18 ^{FB}
Performance					
Max. load	kg [lbs]	1360 [3000]		1580 [3500]	
Basic load center	mm [in.]	600 [24]			
Lift height	mm [in.]	3000 [118.1]			
Tilt angle (fwd-bwd)	°	6 - 12			
Free lift	mm [in.] A	155 [6.1]			
Lift speed	mm/s [fpm]				
(unloaded)		680 [133.9]	660 [129.9]	680 [133.9]	660 [129.9]
(loaded)		650 [127.9]	620 [122.1]	650 [127.9]	620 [122.1]
Traveling speed	km/h [mph]				
fwd		19.5 [12.1]			
1st		*			
2nd		*			
rev		19.5 [12.1]			
1st					
2nd					
Max. drawbar pull	kN [(kgf)] [lbf]				
(unloaded)		6.9 {700}			
(loaded)		[1540]	18.6 {1900}	15.7 {1600}	18.6 {1900}
		[3530]	[4190]	[3530]	[4190]
Gradeability					
(unloaded)		1/5.5		1/5.8	
(loaded)		1/3.0		1/3.2	
Min. turning radius	mm [in.] B	1980 [78]		2010 [79.1]	
Min. 90° intersecting aisle	mm [in.] C	1780 [70.1]		1800 [70.9]	
Dimensions	mm [in.]				
Overall length		3165 [124.6]		3195 [125.8]	
Overall width		1070 [42.1]		1100 [43.3]	
Overall height		2070 [81.5]			
(at overhead guard)					
Overall height with extended mast		4250 [167.3]			
Wheelbase		1425 [56.1]			
Tread				920 [36.2]	
(front)		890 [35]			
(rear)		920 [36.2]			
Fork overhang		395 [15.6]			
Rear overhang		425 [16.7]		455 [17.9]	
Fork size		920 x 100 x 35			
(Length (N) x Width (P) x Thickness (Q))		[36.2 x 3.9 x 1.4]			
Fork spacing		200 - 920			
		[7.9 - 36.2]			
Under clearance (at frame)		105 [4.1]			
Weight	kg [lbs]				
Operating weight		2510 [5530]	2620 [5780]	2670 [5580]	2780 [6120]

SPECIFICATIONS (2)

Item	Truck model	FG20 _{T3}	FHG20 _{T3}	FG25 _{T3}	FHG25 _{T3}	FG30 _{T3}	FHG30 _{T3}
Performance							
Max. load	kg [lbs] mm [in.]	1810 [4000] 600 [24]		2260 [5000]		2720 [6000]	
Basic load center	mm [in.]	3000 [118.1]					
Lift height	mm [in.]	6 - 12					
Tilt angle (fwd-bwd)	°	160 [6.3]				135 [5.3]	
Free lift	mm [in.] A						
Lift speed	mm/s [fpm]	590 [116.3] 580 [114.2]	640 [125.9] 620 [122.1]	590 [116.3] 580 [114.2]	640 [125.9] 620 [122.1]	500 [98.4] 490 [96.4]	540 [106.3] 520 [102.4]
Traveling speed	km/h [mph]	19.0 [11.8]				19.5 [12.1]	
fwd		*					
2nd							
rev		19.0 [11.8]				19.5 [12.1]	
2nd		*					
Max. drawbar pull	kN [kgf] [lbf]						
(unloaded)		8.3 [850] [1866]				9.8 [1000] [2203]	
(loaded)		16.7 [1700] [3754]	22.1 [2250] [5000]	16.7 [1700] [3754]	22.1 [2250] [5000]	14.2 [1450] [3192]	19.6 [2000] [4400]
Gradeability		1/5.0	1/5.6	1/5	1/5.6	1/5	1/5.6
(unloaded)		1/3.5	1/2.8	1/4.2	1/3.0	1/5.6	1/4.1
(loaded)		2170 [85.4]		2240 [88.2]		2400 [94.5]	
Min. turning radius	mm [in.] B	1920 [75.6]		2010 [79.1]		2110 [83.1]	
Min. 90° intersecting aisle	mm [in.] C						
Dimensions	mm [in.]						
Overall length	D	3555 [140]		3625 [142.7]		3775 [148.6]	
Overall width	E	1150 [45.3]				1225 [48.2]	
Overall height	F	2070 [81.5]				2090 [82.3]	
(at overhead guard)							
Overall height with extended mast	G	4250 [167.3]				4260 [168]	
Wheelbase	H	1600 [63.0]				1700 [66.9]	
Tread							
(front)	J	970 [38.2]				1000 [39.4]	
(rear)	K	970 [38.2]					
Fork overhang	L	450 [17.7]		450 [17.7]			
Rear overhang	M	435 [17.1]		505 [19.9]		480 [18.9]	
Fork size		1070 x 122 x 40		1070 x 122 x 40		1070 x 125 x 45	
(Length (N) x Width (P) x Thickness (Q))	R	[42.1 x 4.8 x 1.6]		[42.1 x 4.8 x 1.6]		[42.1 x 4.9 x 1.8]	
Fork spacing		245 - 1020				250 - 1090	
Under clearance (at frame)		110 [4.33]				140 [5.5]	
Weight							
Operating weight	kg [lbs]	3210 [7080]	3220 [7110]	3570 [7870]	3580 [7890]	4250 [9370]	4260 [9390]

SPECIFICATIONS (3)

Item	Truck model	FD20 _{FB}	FHD20 _{FA}	FD25 _{FB}	FHD25 _{FA}	FD30 _{FB}	FHD30 _{FA}
Performance							
Max. load	kg [lbs] mm [in.]	1810 [4000] 600 [24]		2260 [5000]		2720 [6000]	
Basic load center	mm [in.]	3000 [118.1]					
Lift height	mm [in.]	6 - 12					
Tilt angle (fwd-bwd)	°						
Free lift	mm [in.] A	160 [6.3]				135 [5.3]	
Lift speed	mm/s [fpm]						
(unloaded)		670 [131.9]	640 [126.0]	670 [131.9]	640 [126.0]	590 [116.1]	540 [106.3]
(loaded)		630 [124.0]	620 [122.1]	630 [124.0]	620 [122.1]	520 [102.4]	520 [102.4]
Traveling speed	km/h [mph]						
fwd		18.5 [11.5]				19.5 [12.1]	
1st	*						
2nd	*	18.5 [11.5]				19.5 [12.1]	
rev							
1st							
2nd							
Max. drawbar pull	kN [kgf] [lbf]						
(unloaded)		8.3 { 850 }				9.8 { 1000 }	
		[1866]				[2203]	
(loaded)		19.1 { 1950 }	26.5 { 2700 }	19.1 { 1950 }	26.5 { 2700 }	17.2 { 1750 }	23.5 { 2400 }
		[4300]	[6000]	[4300]	[6000]	[3850]	[5300]
Gradeability							
(unloaded)		1/5.0					
(loaded)		1/2.9	1/2.9	1/3.5	1/3.5	1/4.8	
Min. turning radius	mm [in.] B	2170 [85.4]		2240 [88.2]		2400 [94.5]	
Min. 90° intersecting aisle	mm [in.] C	1920 [75.6]		2010 [99.1]		2110 [83.1]	
Dimensions	mm [in.]						
Overall length	D	3555 [140]		3625 [142.7]		3775 [148.6]	
Overall width	E	1150 [45.3]				1225 [48.2]	
Overall height	F	2070 [81.5]				2090 [82.3]	
(at overhead guard)							
Overall height with extended mast	G	4250 [167.3]				4260 [168]	
Wheelbase	H	1600 [63.0]				1700 [66.9]	
Tread							
(front)	J	970 [38.2]				1000 [39.4]	
(rear)	K	970 [38.2]					
Fork overhang	L	450 [17.7]		450 [17.7]		480 [18.9]	
Rear overhang	M	435 [17.1]		505 [19.9]		525 [20.7]	
Fork size	N	1070 x 122 x 40		1070 x 122 x 40		1070 x 125 x 45	
(Length (N) x Width (P) x Thickness (Q))		[42.1 x 4.8 x 1.6]		[42.1 x 4.8 x 1.6]		[42.1 x 4.9 x 1.8]	
Fork spacing	R	245 - 1020				250 - 1090	
		[9.65 - 40.2]				[9.8 - 42.9]	
Under clearance (at frame)		110 [4.33]				140 [5.5]	
Weight							
Operating weight	kg [lbs]	3340 [7360]		3700 [8160]		4390 [9680]	

SPECIFICATIONS (4)

Item	Truck model	FG35 _{ES}	FD35 _{ES}
Performance			
Max. load	kg [lbs] mm [in.]	3500 [7000] 500 [24]	· ·
Basic load center	mm [in.]	3000 [118.1]	·
Lift height	mm [in.]	6 - 12	·
Tilt angle (fwd-bwd)	°	170 [6.7]	·
Free lift	mm [in.] A		
Lift speed	mm/s [fpm]	450 [88.6] 440 [86.6]	490 [96.5] 460 [90.6]
(unloaded)			
(loaded)			
Traveling speed	km/h [mph]	19.5 [12.1]	·
1st		*	
2nd		*	
rev		19.5 [12.1]	·
1st			
2nd			
Max. drawbar pull	kN [kgf] [lbf]	10.8 {1100}	·
(unloaded)		[2420]	18.1 {1850}
(loaded)		[4250]	[4070]
Gradeability		1/6.4	1/6
(unloaded)		1/6	1/5.5
(loaded)		2470 [97.2]	·
Min. turning radius	mm [in.] B	2280 [89.8]	·
Min. 90° intersecting aisle	mm [in.] C		
mm [in.]			
Dimensions			
Overall length	mm [in.] D	3870 [152.4]	·
Overall width	mm [in.] E	1290 [50.8]	·
Overall height	mm [in.] F	2140 [84.3]	·
(at overhead guard)			
Overall height with extended mast	mm [in.] G	4255 [167.5]	·
Wheelbase	mm [in.] H	1700 [66.9]	·
Tread	mm [in.] I	1060 [41.7]	·
(front)		970 [38.2]	·
(rear)		495 [19.5]	·
Fork overhang	mm [in.] J	605 [23.8]	·
Rear overhang	mm [in.] K	1070 x 150 x 50	·
Fork size	mm [in.] L	[42.1 x 5.9 x 2.0]	·
(Length (N) x Width (P) x Thickness (Q))			
Fork spacing	mm [in.] M	300 - 1090	·
Under clearance (at mast)	mm [in.] N	[11.8 - 42.9]	·
mm [in.] O		145 [5.7]	·
Weight			
Operating weight	kg [lbs]	4940 [10870]	4820 [10605]

Unit: mm [in.]

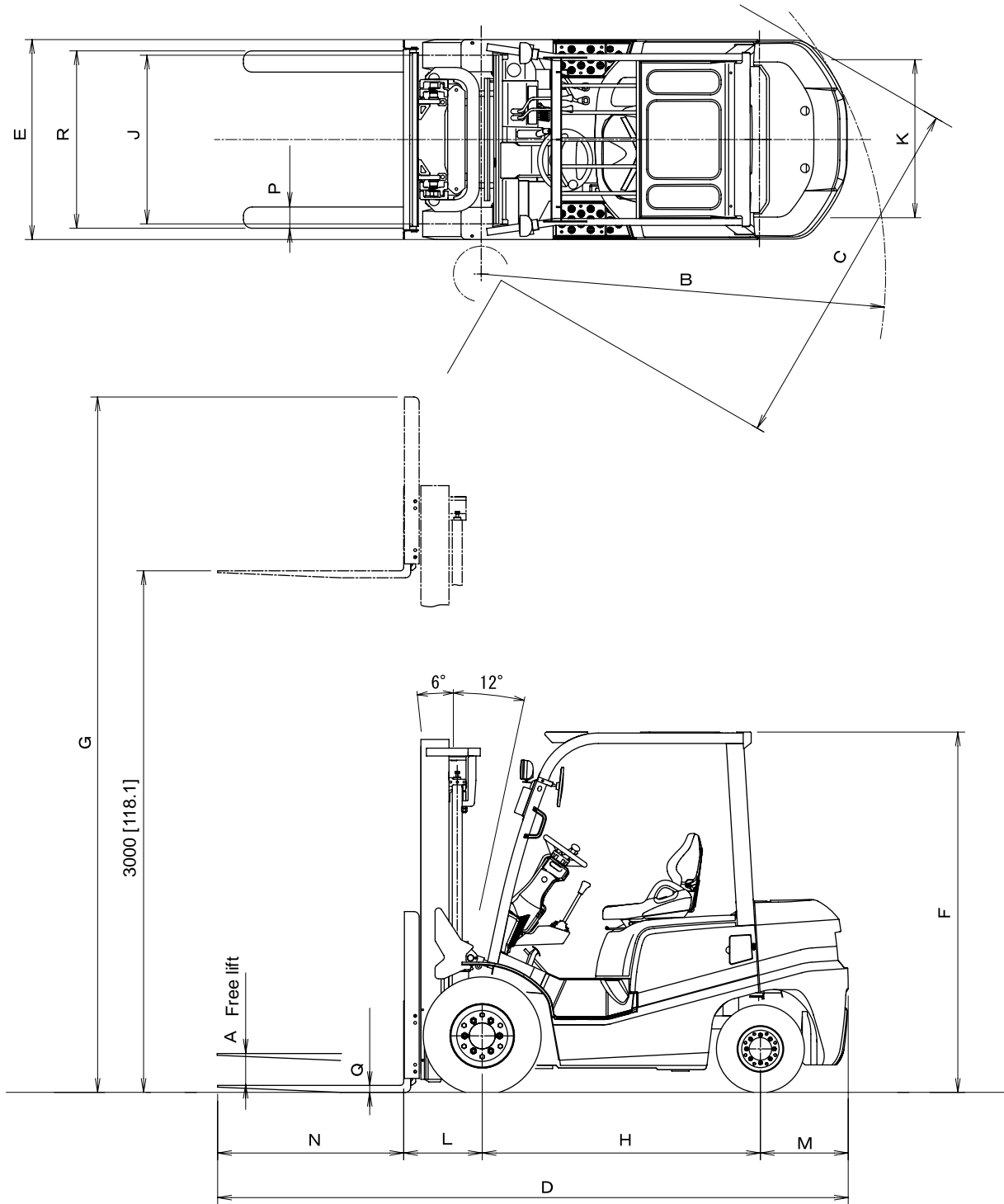

Fig. 1 Truck Dimensions

TABLE OF CONTENTS

1. ENGINE	1
1.1 GENERAL DESCRIPTION	3
1.1.1 FUEL SYSTEM (Gasoline and Diesel).....	10
1.1.2 FUEL SYSTEM (LPG)	17
1.1.3 ENGINE CONTROL SYSTEM (Gasoline and LPG)	19
1.1.4 COOLING SYSTEM	22
1.1.5 ACCELERATOR PEDAL.....	27
1.1.6 AIR CLEANER.....	29
1.1.7 MUFFLER.....	35
2. AUTOMATIC TRANSMISSION SYSTEM	37
2.1 GENERAL DESCRIPTION	37
2.1.1 TORQUE CONVERTER	40
2.1.2 CHARGING PUMP	41
2.1.3 TRANSMISSION.....	42
2.1.4 TRANSMISSION CONTROL VALVE	46
3. DRIVE AXLE	51
3.1 GENERAL DESCRIPTION	51
3.1.1 REDUCTION GEAR AND DIFFERENTIAL.....	57
4. BRAKE SYSTEM	61
4.1 GENERAL DESCRIPTION	61
4.1.1 BRAKE PEDAL.....	61
4.1.2 MASTER CYLINDER.....	66
4.1.3 WHEEL BRAKE.....	67
4.1.4 PARKING BRAKE LEVER	69
4.1.5 WHEEL BRAKE TROUBLESHOOTING	72
5. STEERING SYSTEM	73
5.1 GENERAL DESCRIPTION	73
5.1.1 STEERING AXLE	74
5.1.2 STEERING WHEEL ASSEMBLY	77
5.1.3 ORBITROL	78
5.1.4 POWER CYLINDER.....	81
5.1.5 STEERING WHEEL DEVIATION CONTROL.....	82

6. HYDRAULIC SYSTEM	85
6.1 GENERAL DESCRIPTION	86
6.1.1 MAIN PUMP.....	86
6.1.2 CONTROL VALVE.....	90
6.1.3 VALVE CONTROLS	103
6.1.4 LIFT CYLINDER	104
6.1.5 FLOW REGULATOR VALVE.....	109
6.1.6 TILT CYLINDER.....	110
6.1.7 OIL TANK.....	111
7. LOAD HANDLING	115
7.1 GENERAL DESCRIPTION	116
7.1.1 OUTER AND INNER CHANNELS.....	116
7.1.2 CARRIAGE.....	118
7.1.3 LOCATIONS OF ROLLERS	120
8. ELECTRIC WIRING	123

1. ENGINE

■ Gasoline and LPG engine

Truck Model	FHG15T3 FHG18T3	FG20T3 FG25T3 FG30T3	FHG20T3 FHG25T3 FHG30T3 FG35T3S
Name	K21		K25
Type	4-cycle, water-cooled, in-line, overhead valve type gasoline engine		
No. of cylinders – Bore x stroke	4 – 89 x 83.0		4 – 89 x 100
mm [in.]	4 – [3.50 x 3.27]		4 – [3.50 x 3.94]
Total displacement	2065 [126]		2488 [151.8]
cc [in. ³]			
Compression ratio			
GAS:	8.7		.
LPG (Exclusive):	9.3		9.2
Dual fuel:	8.7		.
Performance			
Rated speed			2700
rpm			
Rated output	kW {PS} [HP]		
GAS (Exclusive and Dual):	38.7 {52.6} [51.9]		44.7 {60.8} [59.9]
LPG (Exclusive):	40.0 {54.3} [53.7]		44.6 {60.7} [59.8]
LPG (Dual):	39.8 {54.1} [53.4]		44.4 {60.4} [59.4]
Max. torque			
N-m {kgf-m} [lbs-ft]/rpm			
GAS (Exclusive and Dual):	148 {15.1} [109.2]/2000		174 {17.7} [128.4]/1600
LPG (Exclusive):	151 {15.4} [111.4]/2000		185 {18.4} [136.5]/1600
LPG (Dual):	150 {15.3} [110.6]/2000		183 {18.7} [135.0]/1600
Full-load rated fuel consumption			
g/kW-h {g/PS-h}/rpm			
GAS (Exclusive and Dual):	303 {223}/1600		302 {222}/1600
LPG (Exclusive):	230 {169}/2000		215 {158}/1600
LPG (Dual):	235 {173}/2000		223 {164}/1600
No-load minimum speed	700 rpm (off the truck)		
rpm			
Weight	kg [lbs]		
GAS:	151 [333]		152 [335]
LPG (Exclusive):	151 [333]		152 [335]
Dual fuel:	152 [335]		153 [337]
Dimensions	mm [in.]		
	719.4 x 568 x 726 [28.3 x 22.4 x 28.6]		
Ignition order	1-3-4-2		
Rotational direction	Clockwise when viewed from the fan		

■ Diesel engine

Truck Model Item	FHD15_{T3} FHD18_{T3}	FD20_{T3} FD25_{T3} FD30_{T3}	FHD20_{T3A} FHD25_{T3A} FHD30_{T3A} FD35_{T3S}
Name	TD27		QD32
Type	4-cycle, water-cooled, in-line, overhead valve type diesel engine with swirl chamber		
No. of cylinders- Bore x stroke	mm [in.] 4-96 x 92 [4-3.78 x 3.62]	4-99.2 x 102 [4-3.91 x 4.02]	
Total displacement	cc 2663	3153	
Compression ratio	24.6	22	
Performance			
Rated speed	rpm 2300	2300	
Rated output	kW [HP] 41 [55]	44 [60]	
Maximum torque	N-m {kgf-m} [lbf-ft] 170 {17.3} [125]/ 2300	189 {19.3} [139.4]/ 1800	
Full-load rated fuel consumption	g/kw-h {g/ps-h} 253 {186}	255 {187}	
No-load minimum speed	rpm 750	750	
Weight	kg [lbs] 259 [571]	262 [578]	
Dimensions (L x W x H)	mm [in.] 787 x 614 x 722 [31 x 24.2 x 28.4]	794 x 616 x 747 [31.3 x 24.3 x 29.4]	
Ignition order	1 - 3 - 4 - 2		
Rotational direction	Clockwise when viewed from fan.		

1.1 GENERAL DESCRIPTION

This series comes equipped with either a gasoline or diesel engine. The engine is installed inside the truck frame along with the drive unit to deliver power to both the drive and hydraulic systems.

The engine is rubber mounted at four points in the frame.

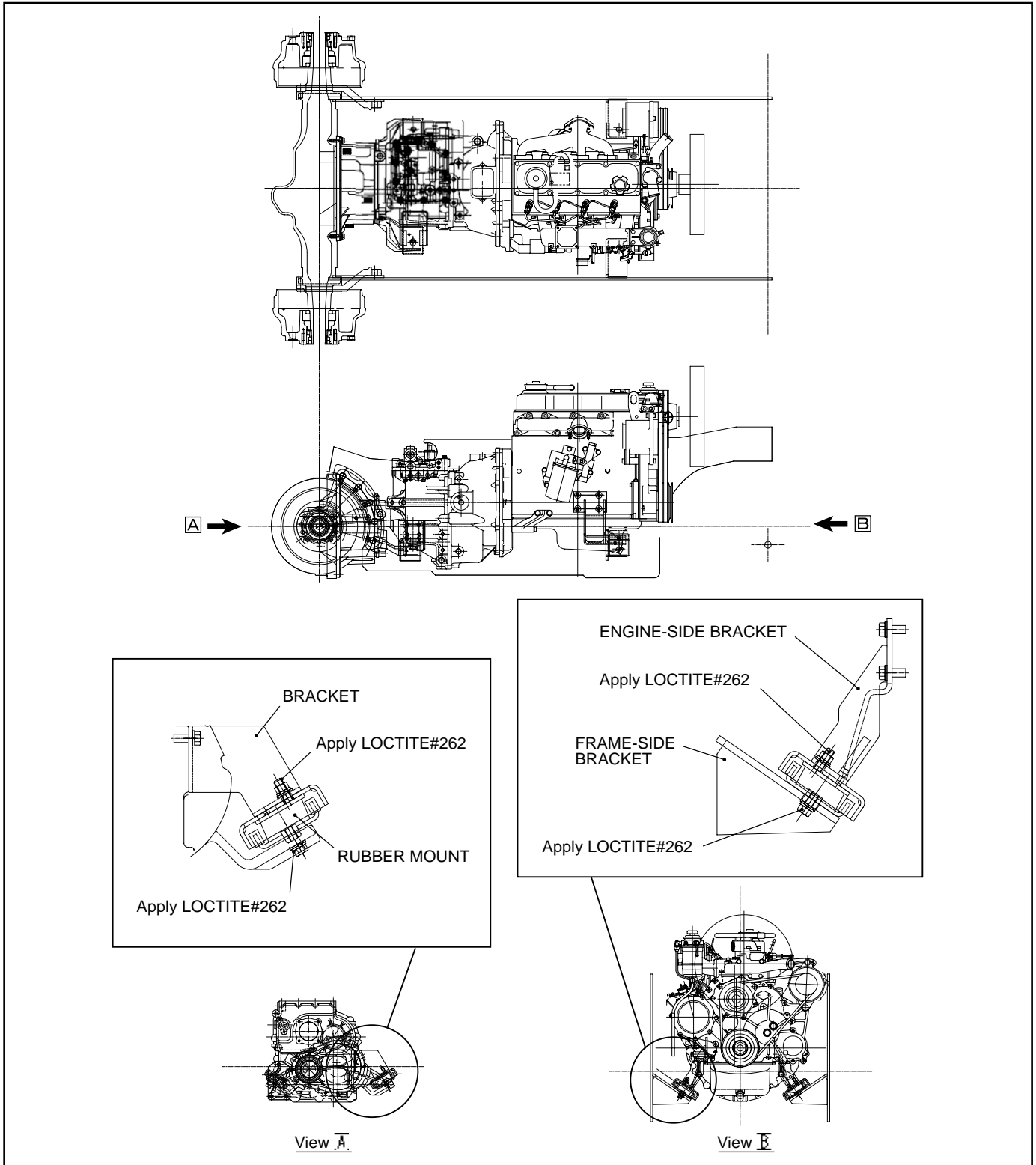

Fig. 1.1 Engine Mounting

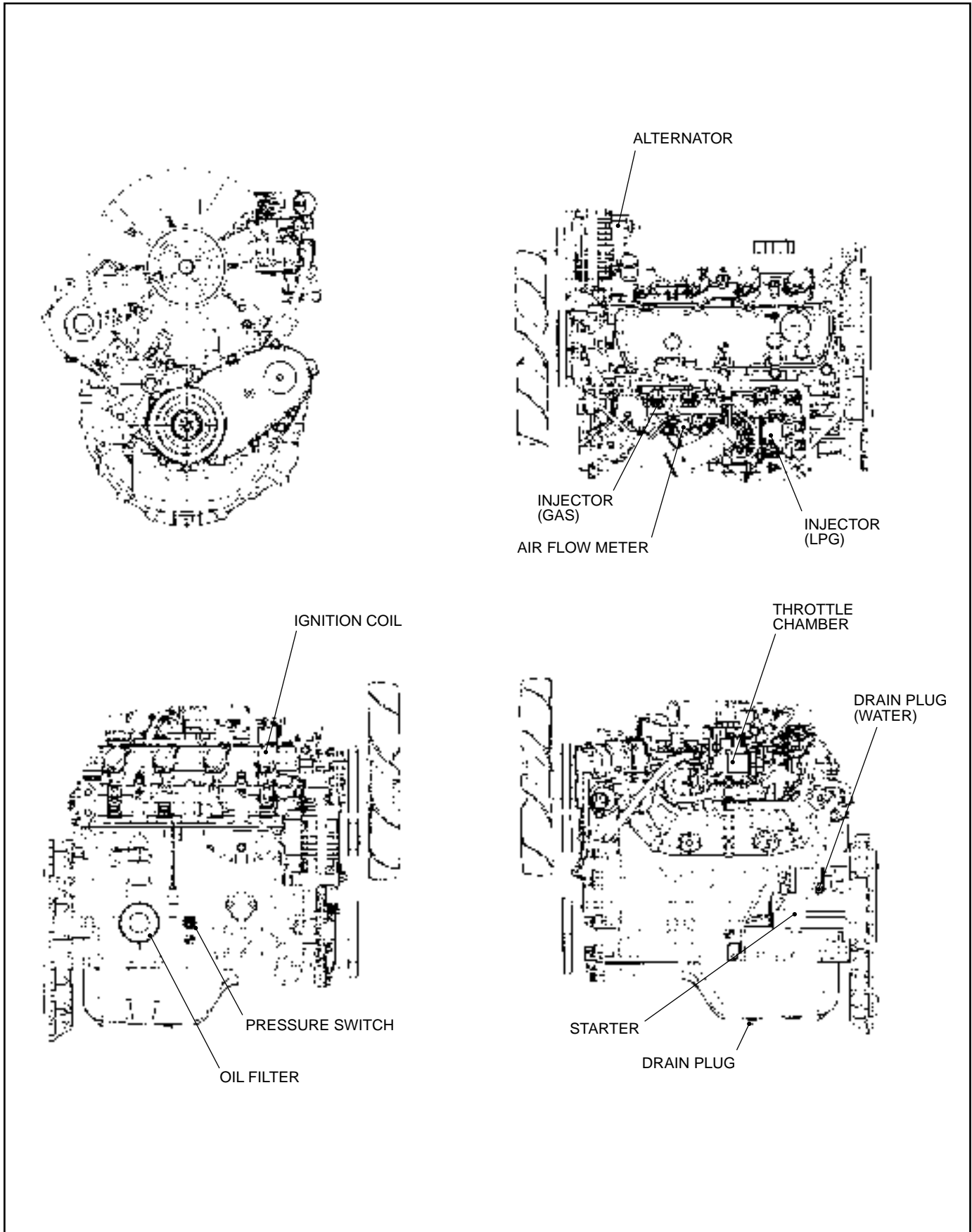

Fig. 1.2 Gasoline and LPG Engines

Item	Model	K21	K25
Main Construction			
Type of cylinder liner		Cylinder and cylinder block cast into one piece	.
Valve operation			
Suction valve			
opens at BTDC:		-4°	.
closes at ABDC:		40°	.
Exhaust valve			
opens at BBDC:		36°	.
closes at ATDC:		0°	.
Valve clearance,			
suction valve		0.38 mm [0.015 in.]	.
exhaust valve		0.38 mm [0.015 in.]	.
Ignition system		Ignition type	.
Ignition timing		BTDC 0° at 700 rpm	.
Ignition order		1 - 3 - 4 - 2	.
Ignition coil		Incorporated in igniter	.
Ignition plug		FR2A-D (NGK)	.
Spark gap		0.8 – 0.9 mm [0.032 – 0.035 in.]	.
Governor		Electronic type, fixed-range control	.
Air cleaner		Filter paper type	.
Lubrication system		Forced lubrication	.
Lubrication pump		Gear type	.
Lubrication oil filter		Filter paper	.
Filtration		Full-flow filtration	.
Cooling system		Water-cooling, forced circulation	.
Cooling fan		Pusher type, 10-blade, O.D. of 400 mm [15.8 in.]	.
Drive		V-belt drive, pulley ratio 1:1.20	.
Water pump		Centrifugal type	.
Drive		V-belt drive, pulley ratio 1:1.20	.
Water temperature regulator		Wax type (valve opening temp.: 82°C or 179.6°F)	.
Starting motor		Magnet shift type	.
Voltage		12 V	.
Output		1.2 kW	.

Item \ Model	K21	K25
Charging generator		
Voltage	12 V	.
Output	50 A	.
Generation	3-phase a.c.	.
Drive	V-belt drive, pulley ratio 1:2.15	.
Voltage/current regulator		
Type	Transistor type (built in charging generator)	.
Water and oil capacities		
Lubrication oil	3.8 liter [1 gal] (oil pan 3.5 liter [0.92 gal], oil filter 0.3 liter [0.08 gal])	.
Cooling water	3.5 liter [0.92 gal]	.

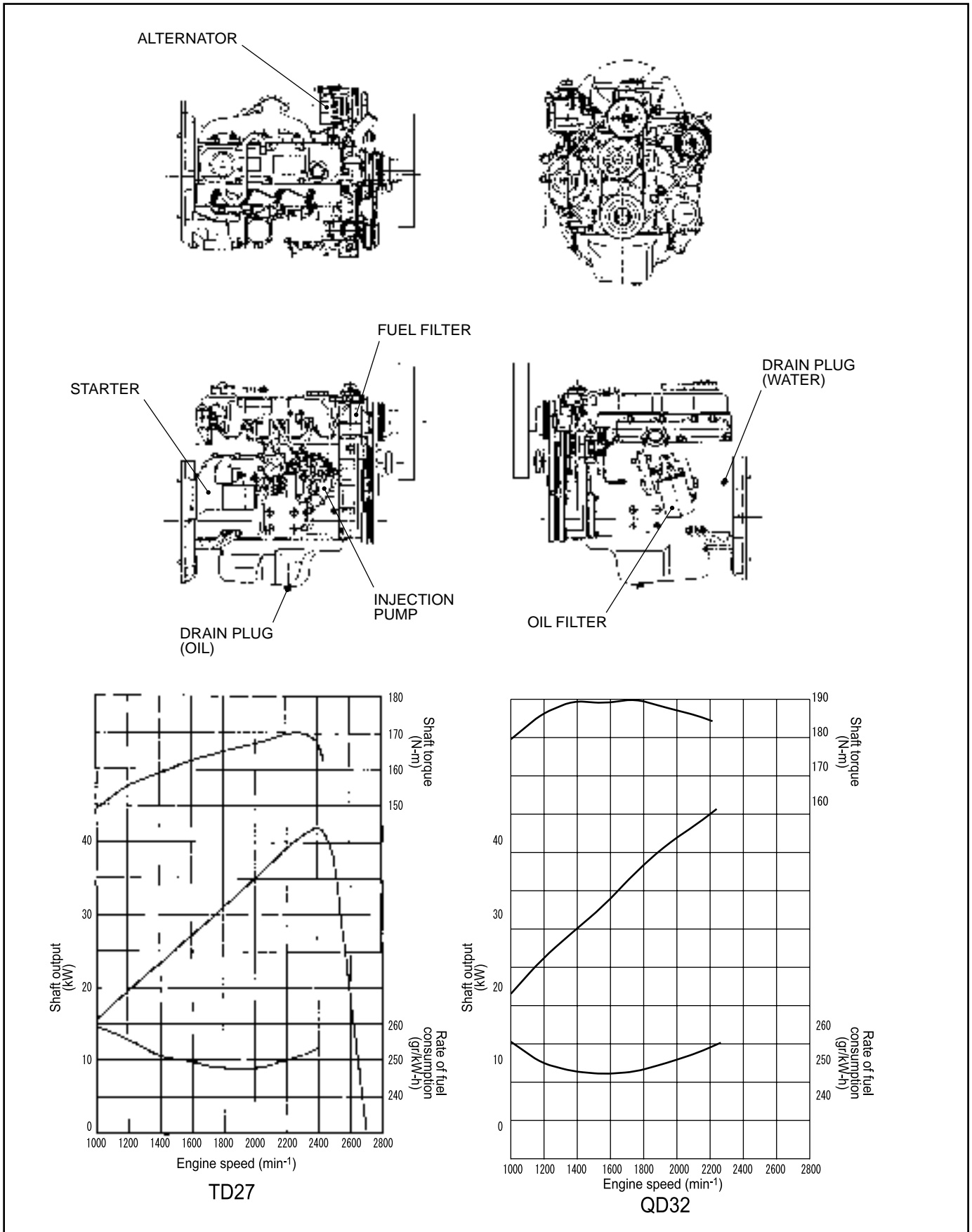

Fig. 1.3 Diesel Engine (TD27, QD32)

Item	Model	TD27	QD32
Main Construction			
Valve system		Overhead valve type	←
Fuel system			
Injection pump		Bosch distributor type	←
Plunger (diameter x stroke)		10 mm x 2.2 mm [0.394 in. x 0.087 in.]	11 mm x 2.88 mm [0.433 in. x 0.113 in.]
Injection nozzle		Throttle type	←
Fuel feed pump		Vane type	←
Fuel filter		Filter paper type with sedimenter	←
Governor			
Governing		Centrifugal, all-speed control	←
Lubrication		Fuel lubrication	←
Lubrication system			
Pump		Gear type	←
Drive		Gear-driven	←
Oil pressure regulator		Regulator valve	←
Oil pressure indicator		Switch type	←
Filtration		Full-flow, filter paper type	←
Oil cooler		Incorporated, water cooling	←
Cooling system			
Cooling method		Water cooling	←
Cooling fan		Pusher type with 6 blades O.D.: 380 mm [14.96 in.]	← O.D.: 430 mm [16.93 in.]
Drive		Belt drive	←
Pump		Centrifugal type	←
Drive		Belt drive	←
Water temperature regulator			
Type		Wax type	←
Temperature at which valve begins to open		82°C [179.6°F]	←
Temperature at which valve opens fully		95°C [203°F]	←
Starting motor			
Type		Magnet shift type	←
Voltage		12 V	←
Output		2.5 kW	2.8 kW
Stopping device		Fuel cut-off type	←
Engine preheater		Provided (QGS)	Provided

Item	Model	TD27	QD32
Charging generator			
Type		A.C. generation, diode rectification	←
Voltage		12 V	←
Output		60 A	←
Drive		Belt drive	←
Automatic charging regulator		IC type (built in generator)	←
Reference data			
Oil sump capacity		5.5 liters [1.45 U.S. gal] max. 4.0 liters [1.06 U.S. gal] min.	6.5 liters [1.72 U.S. gal] max. 5.0 liters [1.32 U.S. gal] min.
Cooling water volume		5.4 liters [1.43 U.S. gal]	6.2 liters [1.64 U.S. gal]
Valve clearance			
Suction valve		0.35 mm [0.014 in.] (at warm)	←
Exhaust valve		0.35 mm [0.014 in.] (at warm)	←
Valve operation			
Suction valve	opens at BTDC	16°	←
	closes at ABDC	52°	←
Exhaust valve	opens at BBDC	66°	←
	closes at ATDC	12°	←
Injection timing (BTDC)		5°	2°
Injection start pressure		9.8 MPa { 100 kgf/cm ² } [1421 psi]	←
Compression pressure		2.94 MPa { 30 kgf/cm ² } [426 psi] (200 rpm)	←

1.1.1 FUEL SYSTEM (Gasoline and Diesel)

The fuel system is integral with the truck frame and consists of a fuel tank, filter, pump and level sender.

(1) Fuel tank (Gasoline)

The fuel tank is welded into one integral body with the frame and located at the left side of the frame. The fuel tank has on its top a tank cover where a tank unit is provided to check the fuel level in the tank.

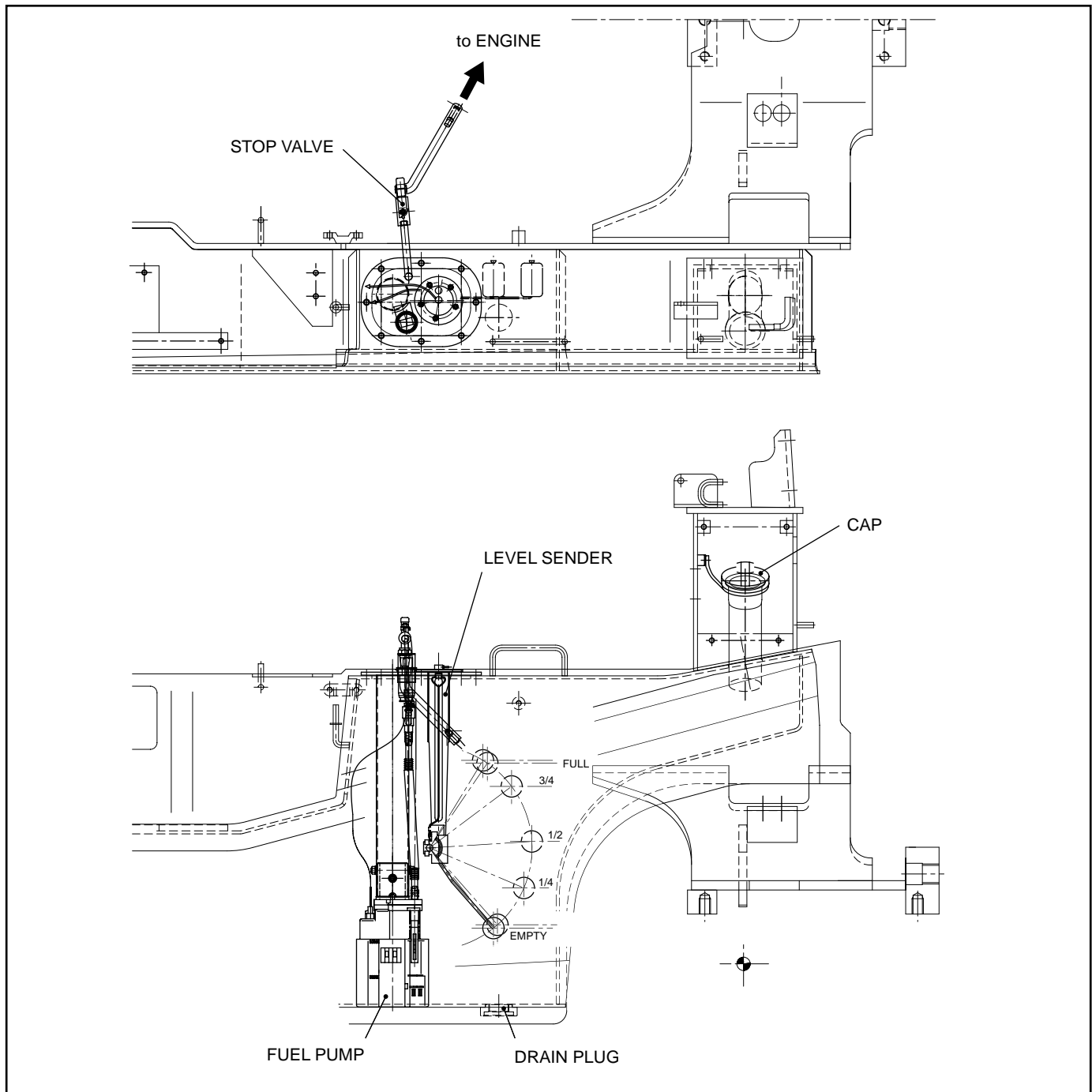

Fig. 1.4 Fuel Tank (Gasoline)

■ Fuel pump (Gasoline)

The fuel pump has a design as shown in Fig. 1.5. It consists of a pump, a regulator and a filter. The fuel pump is started when the key switch is turned to ON, to send fuel under pressure to the engine injector.

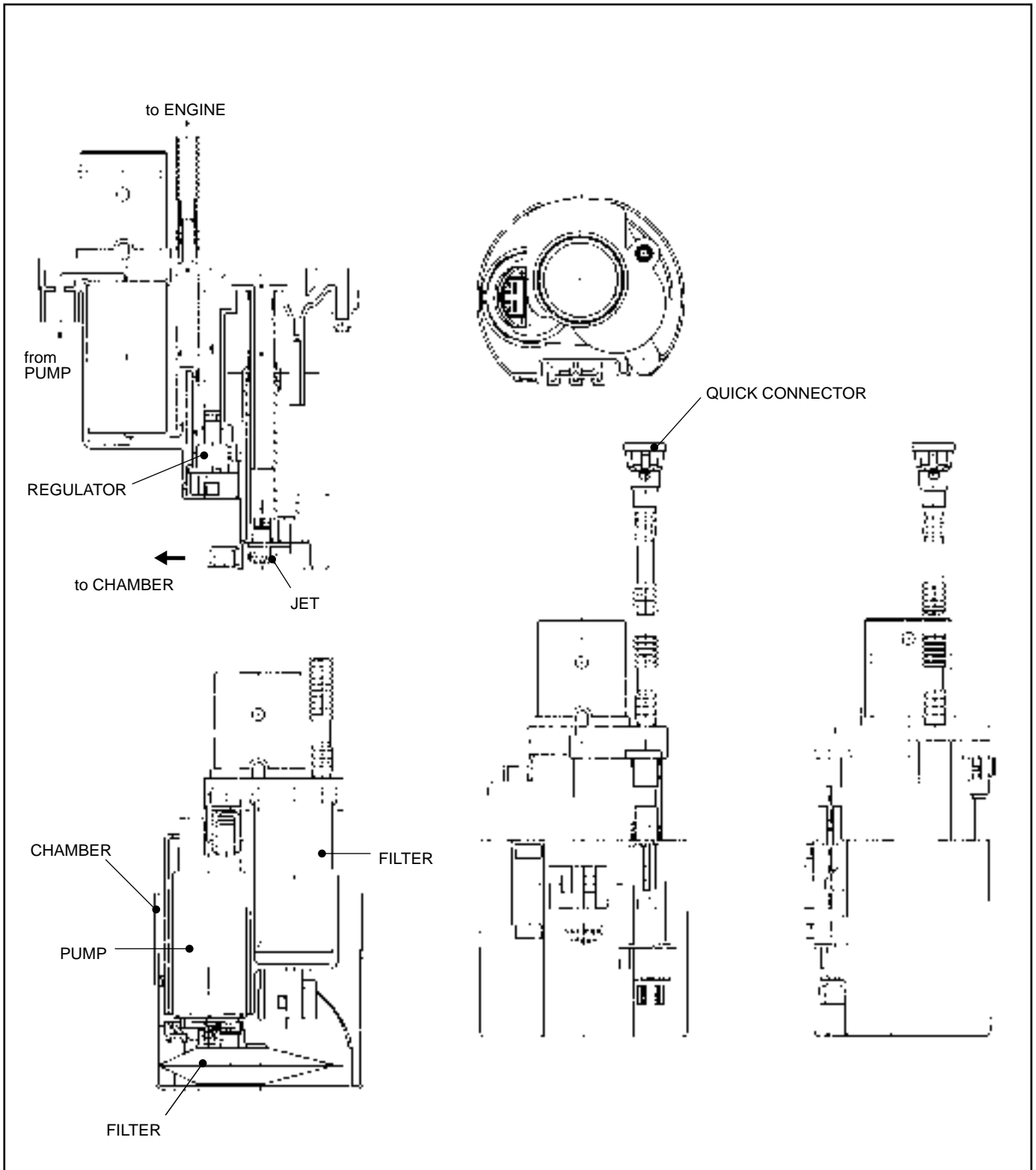

Fig. 1.5 Fuel Pump (Gasoline Engine)

(2) Fuel tank (Diesel)

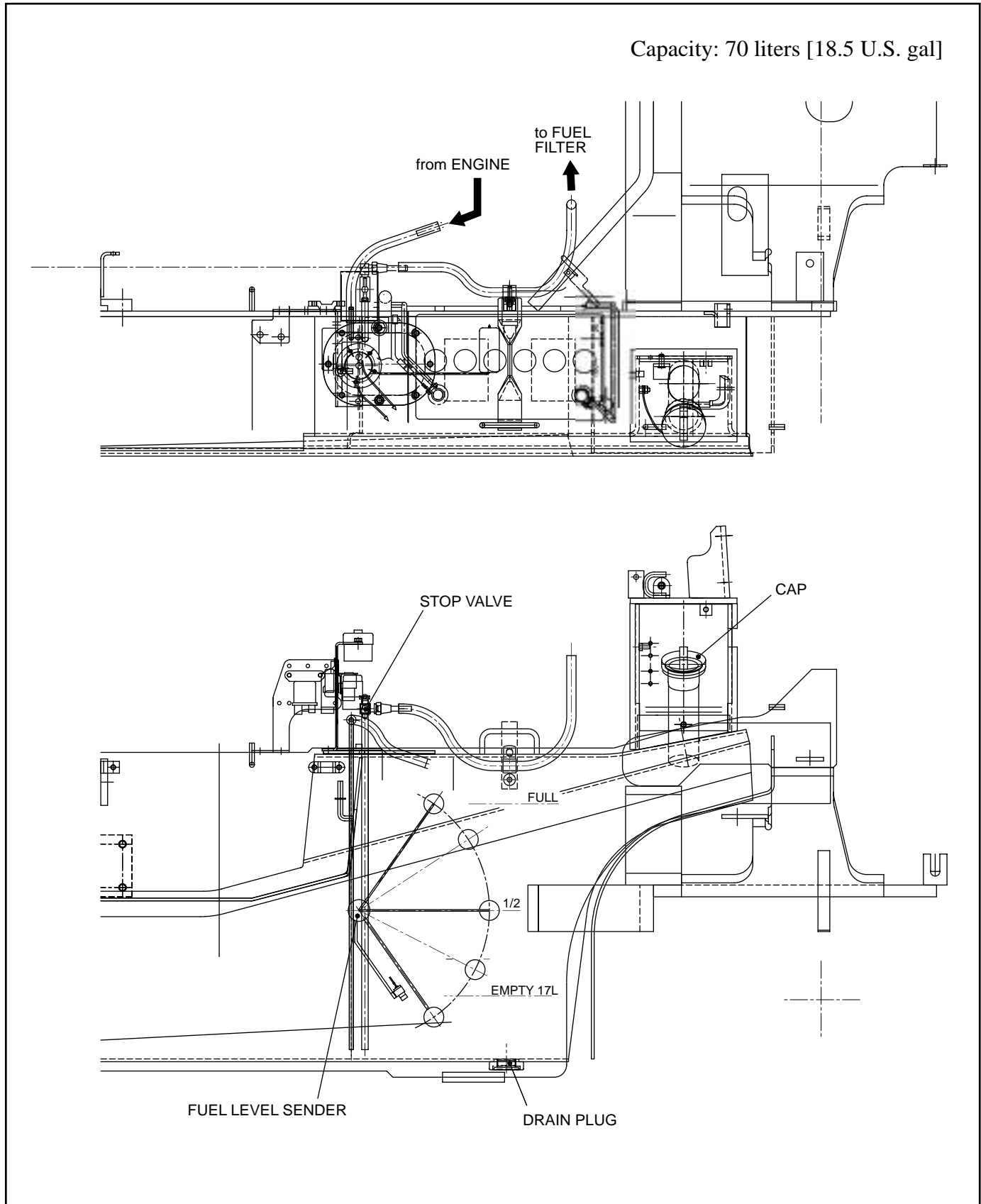

Fig. 1.6 Fuel System (diesel-powered trucks with TD27, QD32)

The fuel level sender converts the fuel level in the fuel tank into an electric current signal. Its construction is shown in Figure 1.7. The resistance element is a variable resistor made of nichrome wire. The slider that changes the resistance is connected to the float.

When the float is at the top level, the resistance value between the grounding and the “G” terminal is in the range of about 9.5 to 10.5 Ω. As the float lowers, the resistance value becomes greater. Changes in the resistance are transmitted to the CPU in the combination meter. The fuel meter indicator moves in the “F” direction when the resistance is small and moves in the “E” direction when the resistance value is large.

In addition, if the float lowers near to the bottom, the CPU sends the signal to light the fuel lamp to inform the operator that fuel should be added.

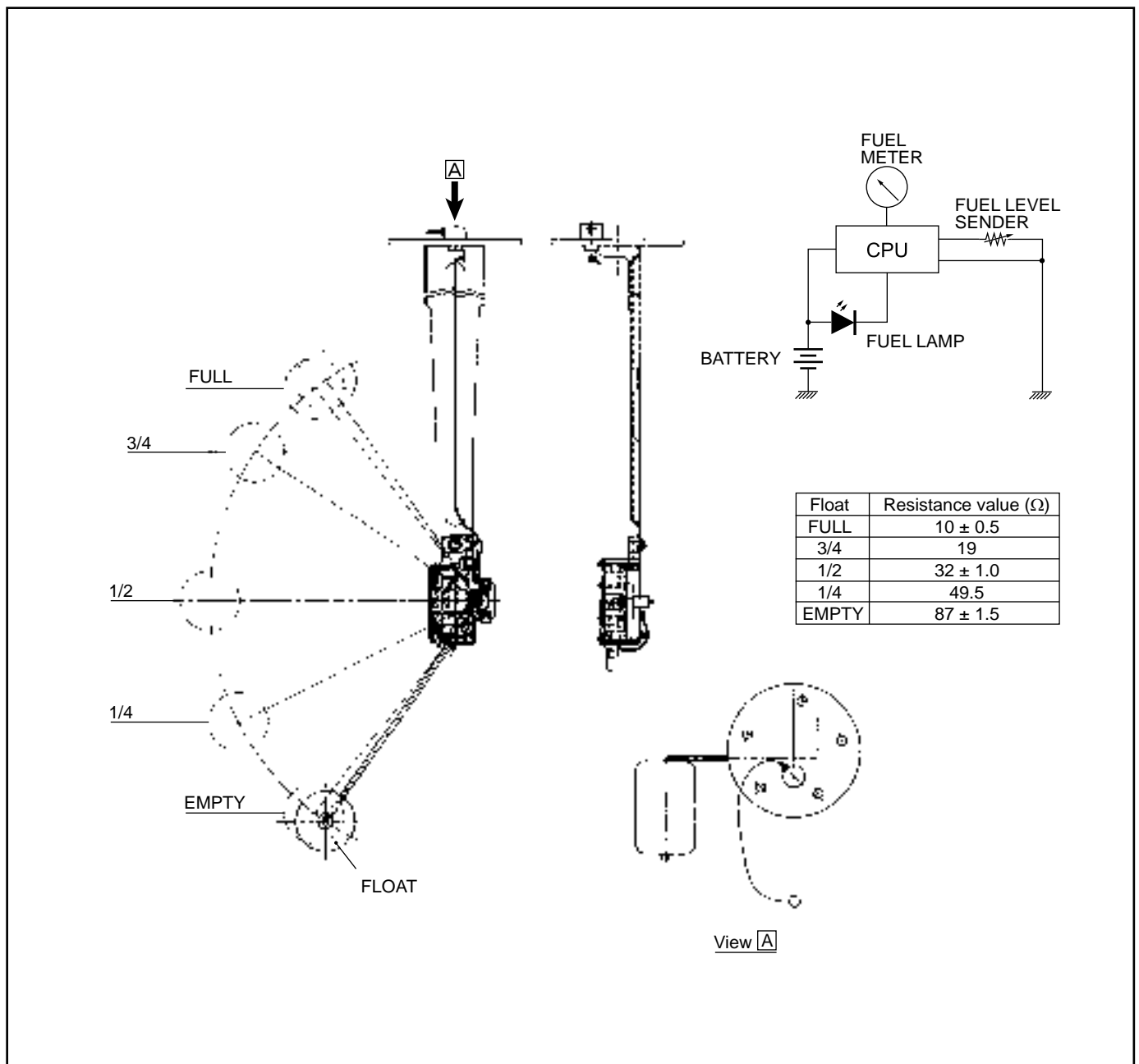
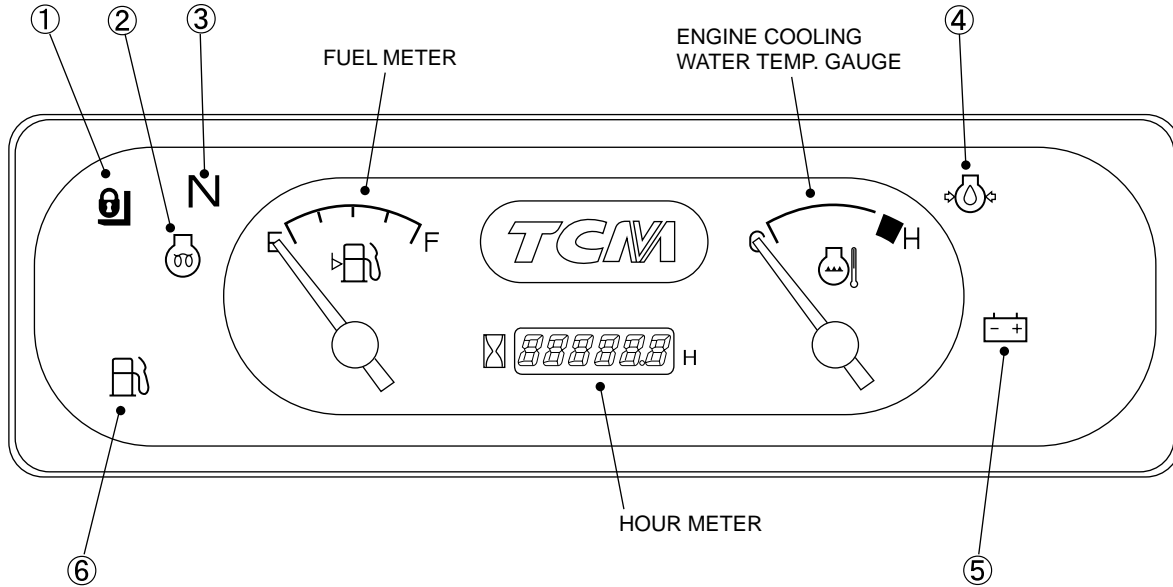

Fig. 1.7 Fuel Level Sender



1. LOAD HANDLING AND TRAVELING INTERLOCK WARNING LIGHT
2. PREHEATER INDICATOR (FOR DIESEL TRUCKS)
3. NEUTRAL WARNING LIGHT
4. ENGINE OIL PRESSURE WARNING LIGHT
5. BATTERY CHARGE WARNING LIGHT
6. FUEL LEVEL WARNING LIGHT

Fig. 1.8 Combination Meter

(3) Fuel Filter (Diesel)

The fuel filter removes dust and dirt from the fuel to be supplied to the engine. It is located on the fuel tank. The fuel filter for the diesel engine model also removes water from the fuel.

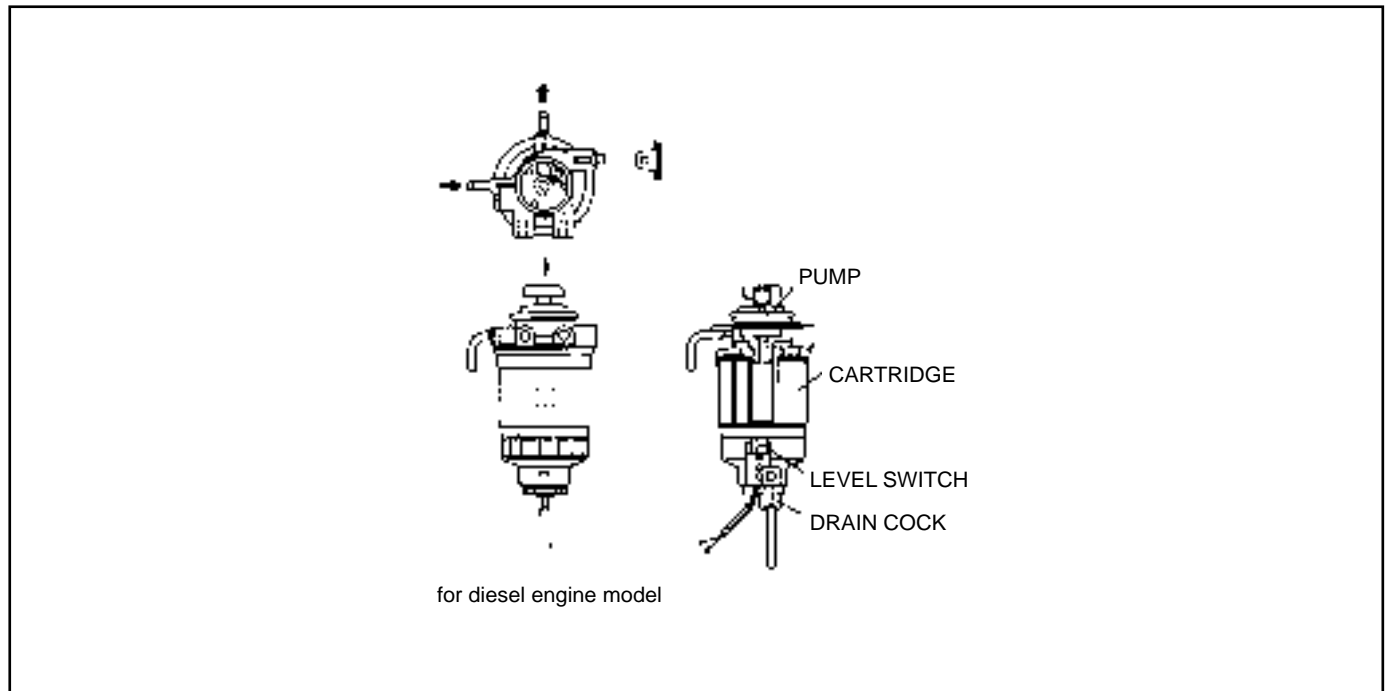

Fig. 1.9 Fuel Filter (Diesel engine)

■ Replacement of fuel filter

There is no need to replace the fuel filter of the gasoline engine, because it is incorporated into the fuel pump.

- (1) Using a filter wrench, remove the filter.
Replacement criteria: Damage or clogging
- (2) Apply fuel oil on the packing of a new filter and install the filter. After the packing comes in contact with the body, give an additional 2/3 of a turn.
- (3) If the sedimentor warning light comes on, loosen the drain cock to drain off water.

Note: After draining off water, make sure to close the drain cock.

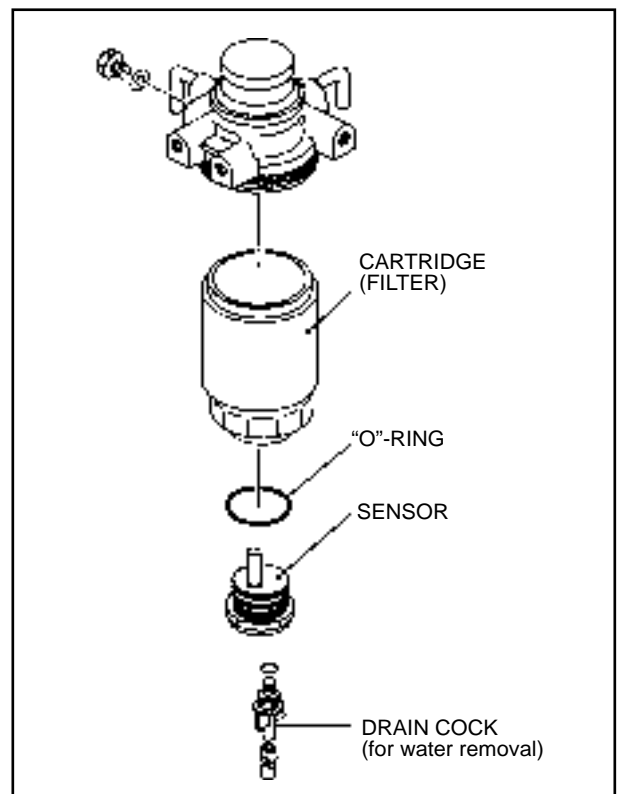

Fig. 1.10

■ **Air bleeding (Diesel engine)**

- 1 Operate the fuel filter (sedimentor) pump to send fuel into the injection pump.
- 2 After it feels a little hard, operate the pump 5 to 10 more times.

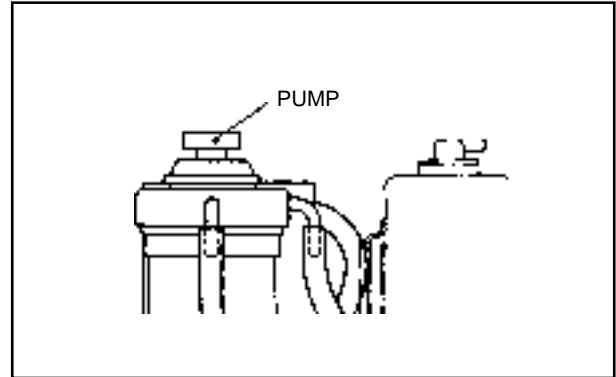

Fig. 1.11 Air Bleeding

1.1.2 FUEL SYSTEM (LPG)

The fuel system that uses LPG as a fuel has a construction shown in Fig. 1.12. It consists of a LPG cylinder, a vaporizer, and a solenoid valve. The LPG cylinder is attached to the upper part of the rear counterweight and both the vaporizer and the solenoid valve are located at the left side inside the engine room.

LPG flows from the LPG cylinder through the solenoid valve to the vaporizer where the gas pressure is properly regulated, before being controlled by the LPG injector and then injected into the cylinders of the engine.

The vaporizer case is warmed by the radiator water to prevent the vaporizer from freezing due to latent heat which occurs when the fuel vaporizes.

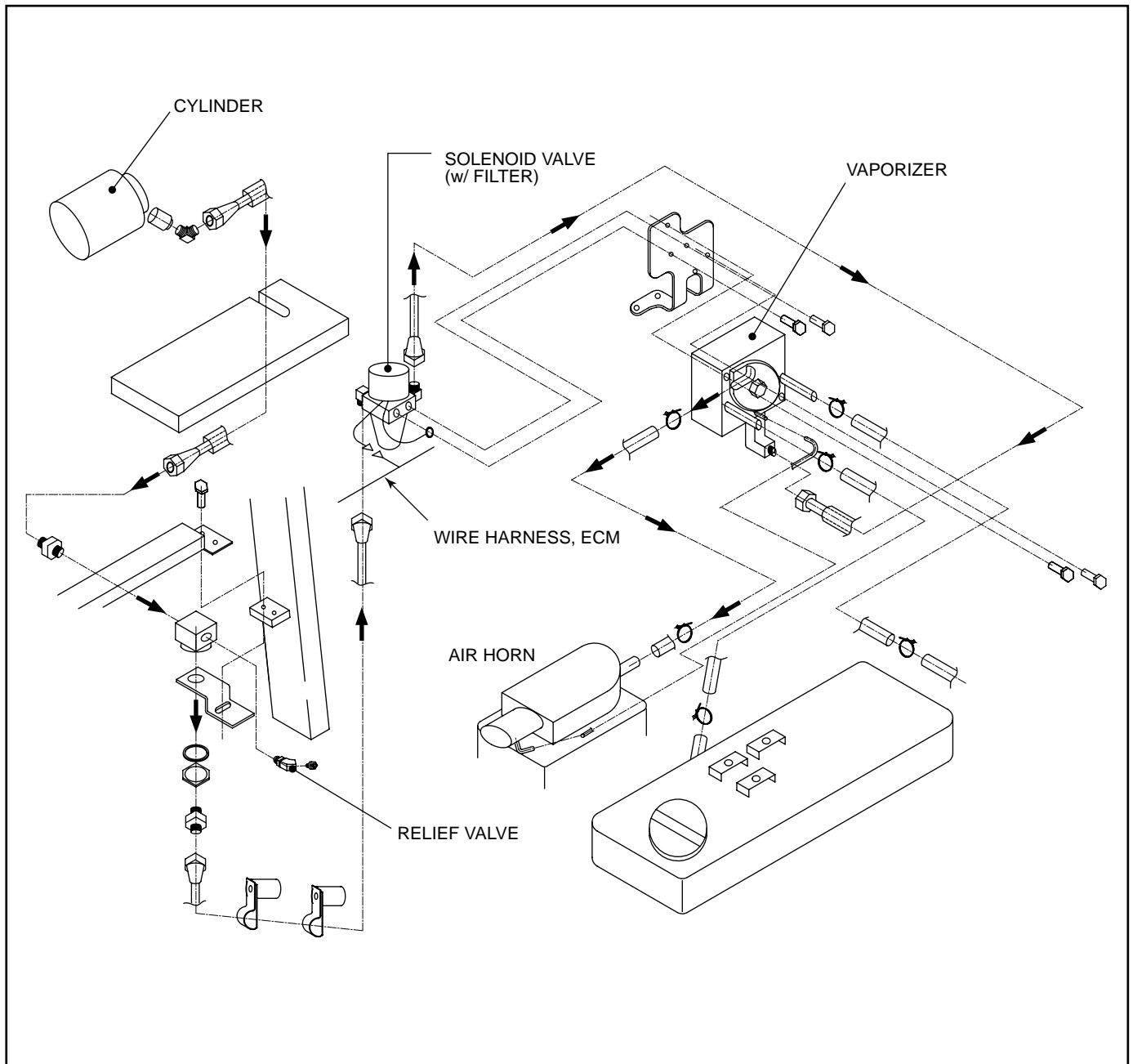

Fig. 1.12 LPG Fuel System (Outline)

■ Vaporizer

The vaporizer has a construction shown in Fig. 1.13. It converts high-pressure gas supplied from the LPG cylinder into low-pressure gas.

High-pressure gas from the LPG cylinder flows between the valve seat and valve and enters the pressure-reducing chamber so that the pressure inside the pressure-reducing chamber rises. Therefore, the diaphragm pushes up the diaphragm spring and the hook pulls up the valve lever so that the valve is pressed against the valve seat. The higher the pressure inside the pressure-reducing chamber, the stronger the valve is pressed against the valve seat. When the pressure inside the pressure-reducing valve is high enough to reach the set value, the gas flow is cut off by the valve.

When the pressure inside the pressure-reducing valve drops below the set value, the diaphragm spring is decompressed to reduce the lever pulling-up force. This opens the valve to allow high-pressure LPG to enter the pressure-reducing chamber.

This process is repeated to maintain the pressure inside the pressure-reducing chamber at a constant value.

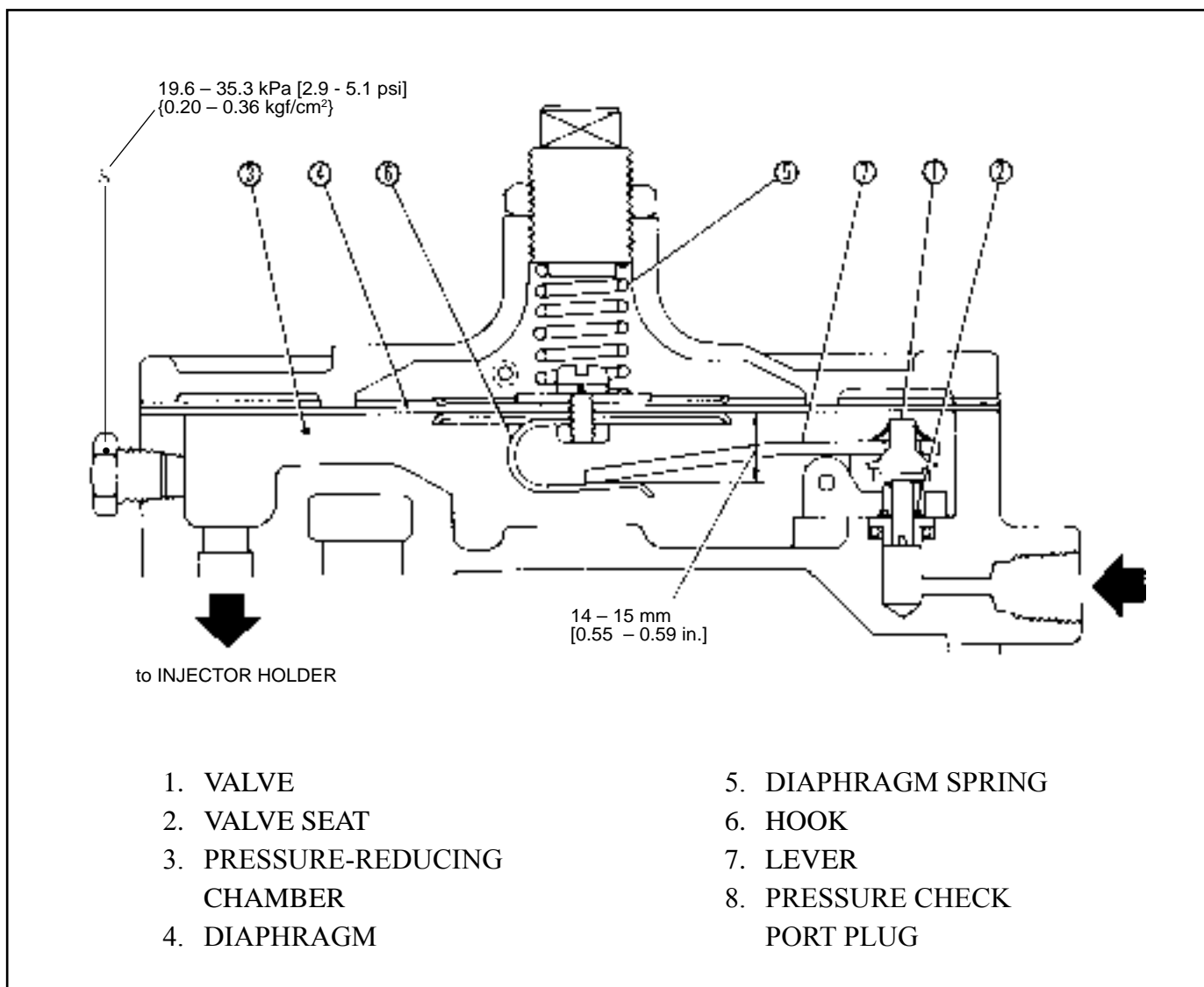

Fig. 1.13 Vaporizer (Outline)

1.1.3 ENGINE CONTROL SYSTEM (Gasoline and LPG)

The gasoline and LPG engines are electronically controlled and the schematic diagrams of their control systems are shown in Figs. 1.19 and 1.20.

The amount of fuel, mixing ratio and ignition timing are controlled by the ECM based on the information about the amount of accelerator pedal depression, the quantity of air to be sucked, and rotating angles of the crankshaft and camshaft.

The amount of accelerator pedal depression is detected by the accelerator sensor shown in Fig. 1.21 and the quantity of air to be sucked is detected by the air flow sensor installed on the air horn.

The rotating angle of the crankshaft is detected by the position sensor (POS) installed on the front cover of the engine and the rotating angle of the camshaft by the position sensor (PHASE) installed inside the chain housing of the engine .

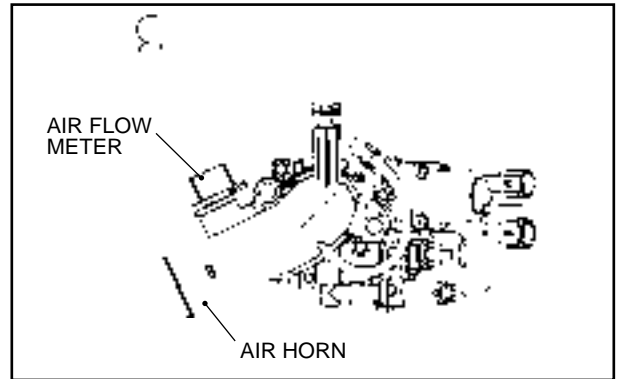

Fig. 1.14 Air Flow Sensor

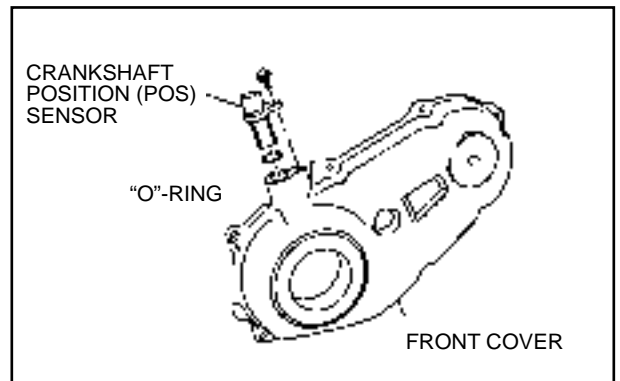

Fig. 1.15 POS

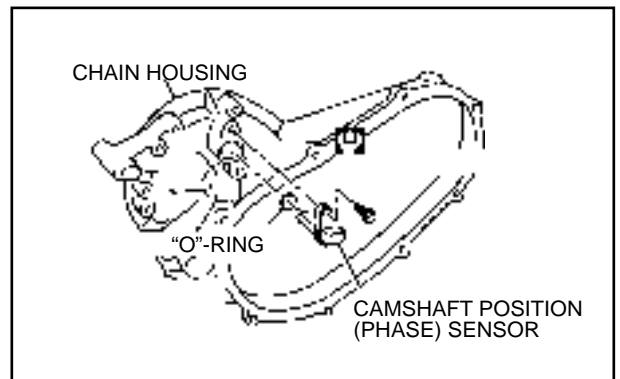

Fig. 1.16 PHASE

■ **Injector (LPG engines)**

The amount of fuel to be injected is controlled by the injectors. Four injectors are installed on the intake manifold and independently controlled respectively.

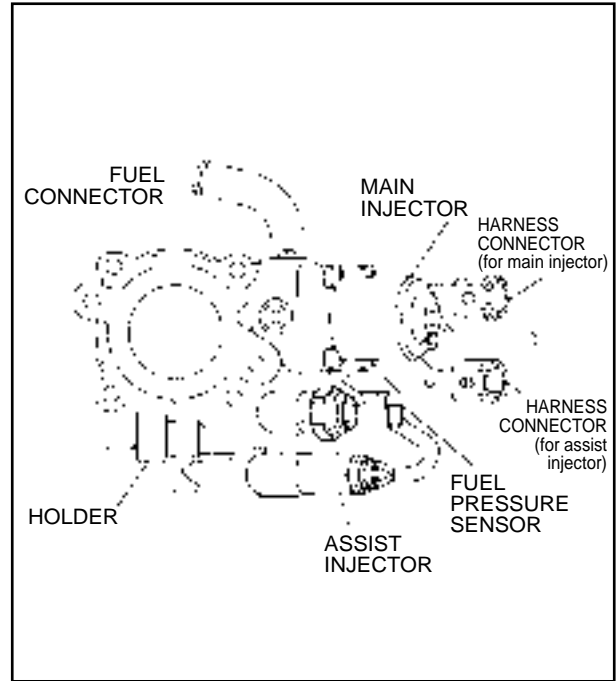

Fig. 1.17 Injector (LPG)

■ **Throttle**

The quantity of air to sucked is controlled by the throttle shown in Fig. 1.18.

The throttle valve is driven by a motor which is controlled by the ECM.

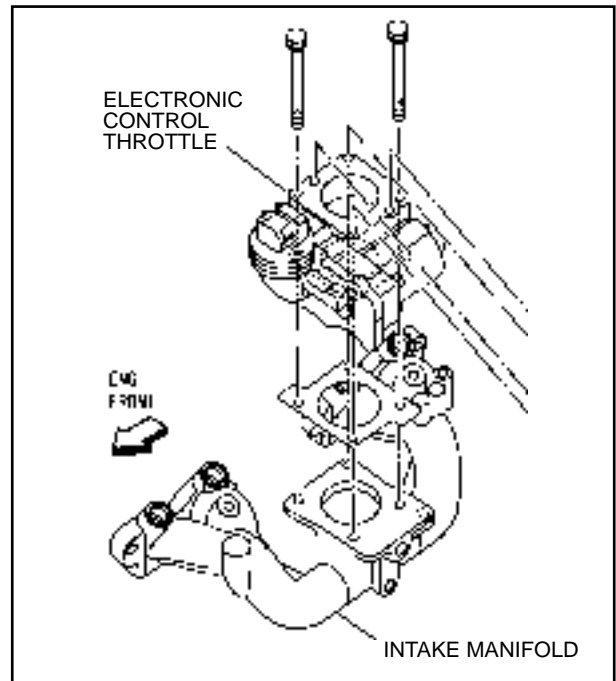

Fig. 1.18 Throttle

■ **Ignition coil**

The ignition coils are used only for the ignition plugs and directly attached to them. Inside each ignition coil is an igniter using transistors.

1.1.4 COOLING SYSTEM

The cooling system consists primarily of a radiator and a reserve tank, as shown in Figure 1.20. The radiator is a cross-flow type. On the automatic transmission trucks, the outlet tank has an oil cooler inside it.

The water pump is attached to the engine and driven by way of the V-belt as the engine starts running.

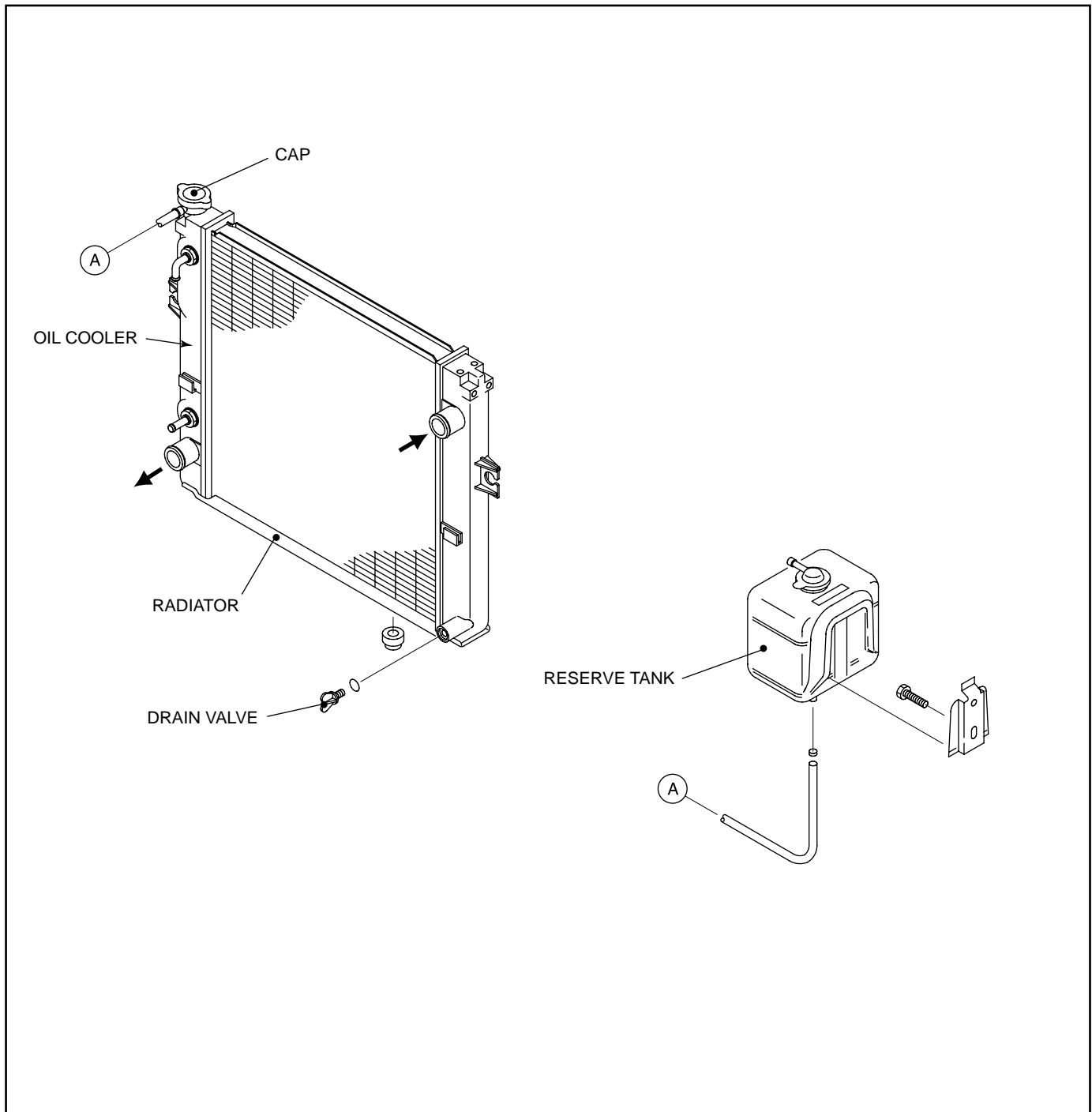

Fig. 1.20 Cooling System

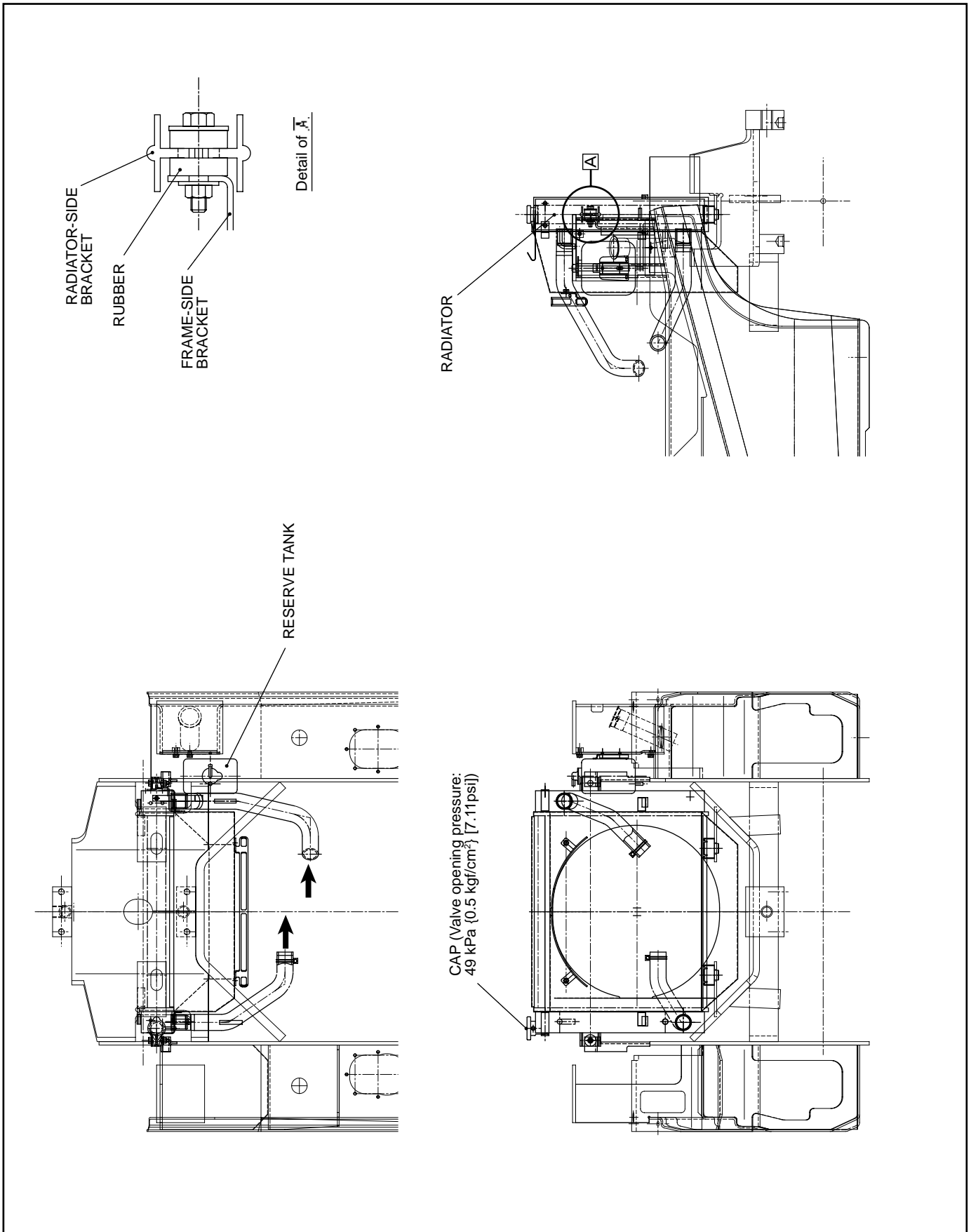

Fig. 1.21 Cooling System (Gas-powered trucks)

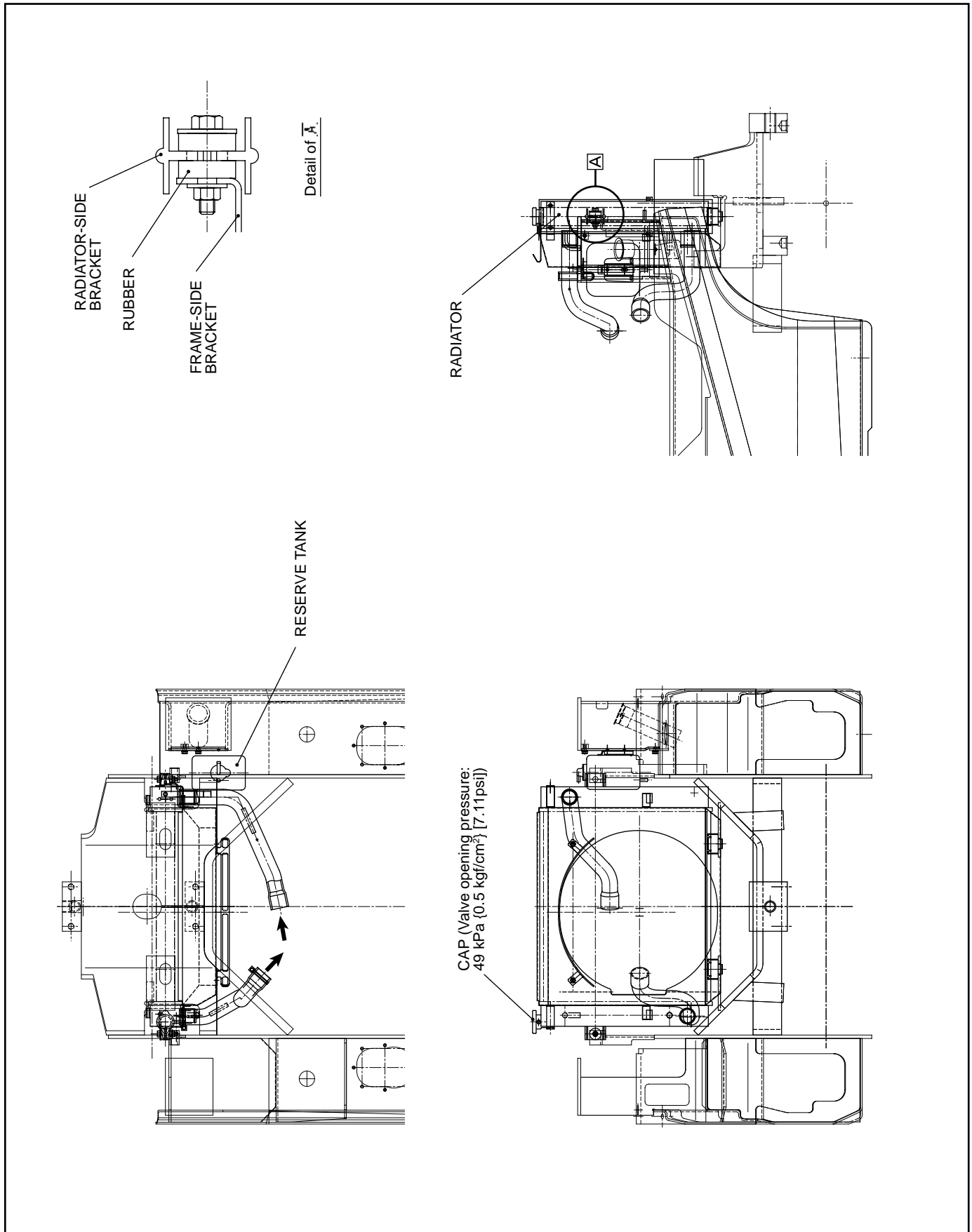

Fig. 1.22 Cooling System (Diesel-powered trucks)

■ **Adjusting fan belt tension**

▲ **Make sure the engine is shut off.**

■ **K21, K25**

- 1 Loosen generator fitting bolts.
- 2 Move the generator away from the engine to adjust the belt tension. So that the fan belt has a deflection of 10 mm at \bar{A} on the span when pressed by a finger pressure of about 98.1 N {10 kgf}.
- 3 Tighten the fitting bolts \bar{E} and then \bar{C} .

■ **TD27, QD32**

- 1 Loosen the tension pulley nut.
- 2 Adjust the adjust bolt so that the fan belt has a deflection of 10 mm when the area \bar{A} is pressed with a force of 98.1 N {10 kgf}.
- 3 Tighten the tension pulley nut.

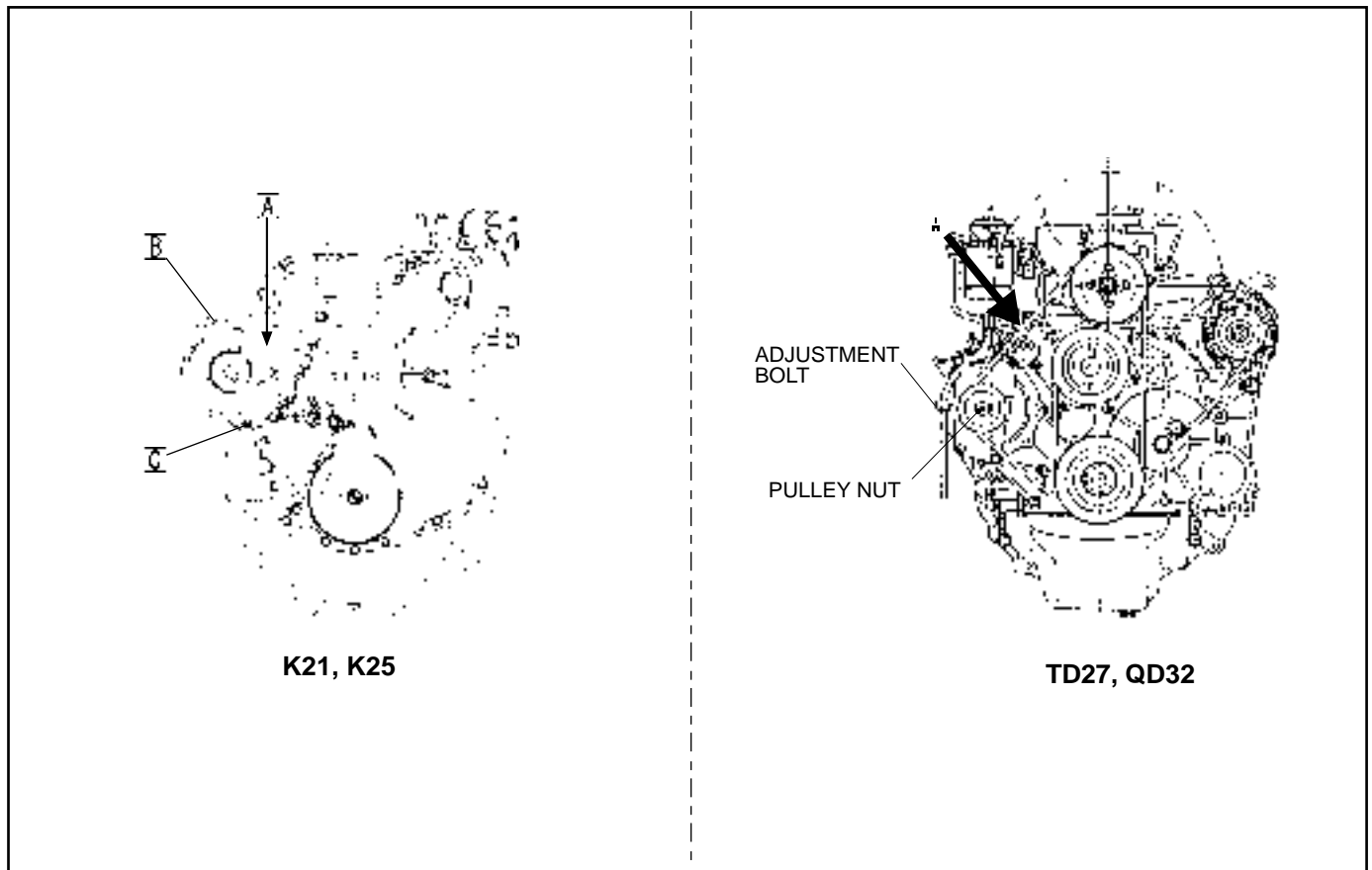

Fig. 1.23 Fan Belt

■ Checking cooling liquid

Check the cooling liquid in the reserve tank. If the level is below the LOW mark, add cooling liquid of appropriate concentration listed in Table 1.1, to bring level:

Up to the FULL mark when the engine is warm 2/3 of the capacity when the engine is cold.

■ Charging cooling liquid

- 1 Shut off the engine and wait for more than 30 minutes.
- 2 Remove the radiator cap and loosen the drain cock at the radiator side.
- 3 Loosen the drain cock at the engine side to drain off the cooling liquid.
- 4 Tighten the drain cocks at both the radiator and the engine sides.
- 5 Add cooling liquid of appropriate concentration listed in Table 1.1, into the radiator. The rate of addition is less than 2 liter/min.

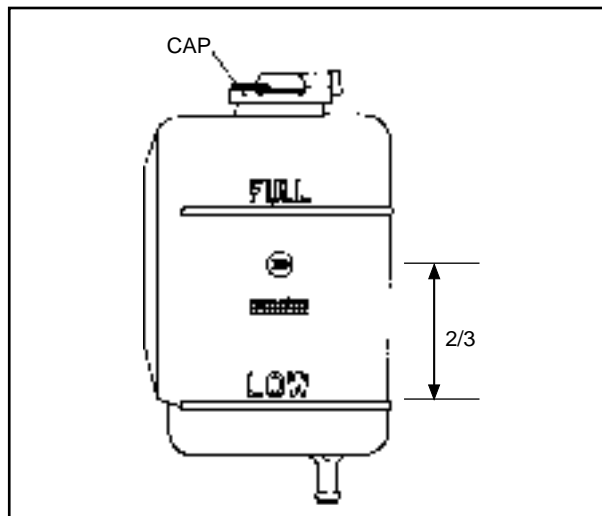

Fig. 1.24 Reserve tank

Table 1.1

Unit: liter

	K21	K25	TD27, QD32
1.5- to 1.75- ton trucks	8.0 [2.11]	*	*
2.0- to 3.5- ton trucks	9.0 [2.38]	.	9.9 [2.62]

Coolant concentration: 30% for general-climate regions
50% for cold regions

- 6 After adding cooling liquid, start the engine and let it run at idle rpm for a couple of minutes and check the cooling liquid level. If the level is low, add appropriate cooling liquid.
- 7 Tighten the radiator cap securely. Add cooling liquid to bring level up to 2/3 of the capacity.

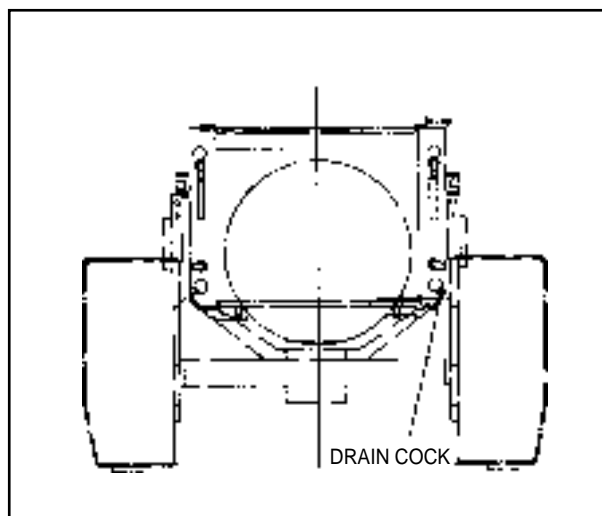

Fig. 1.25 Drain Cock Location

1.1.5 ACCELERATOR PEDAL

(1) Gasoline engine

The accelerator pedal, designed as shown in Fig. 1.26, is installed on the floorboard.

The movement of the pedal is converted into voltage by the potentiometer and outputted to the engine control module.

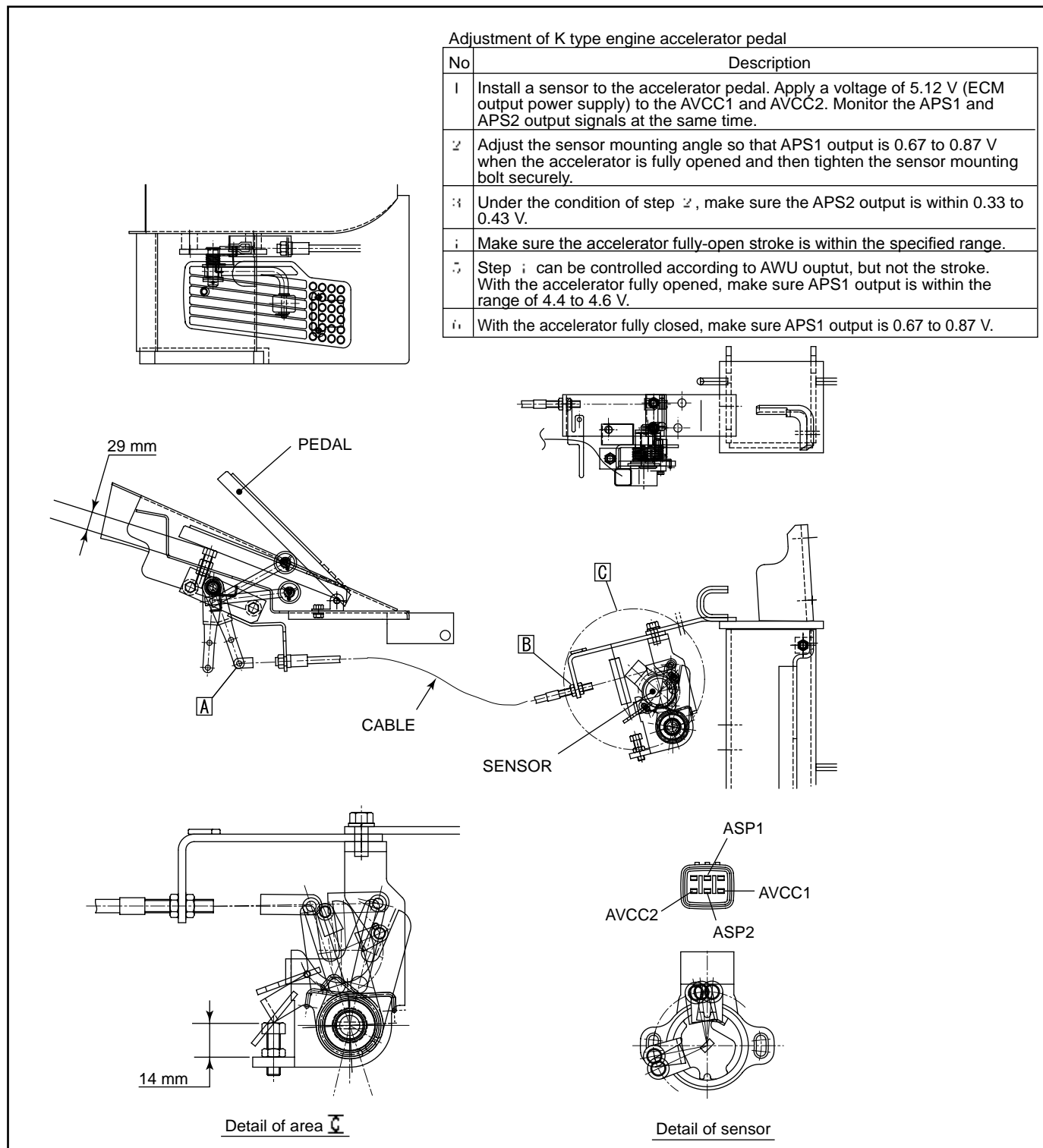
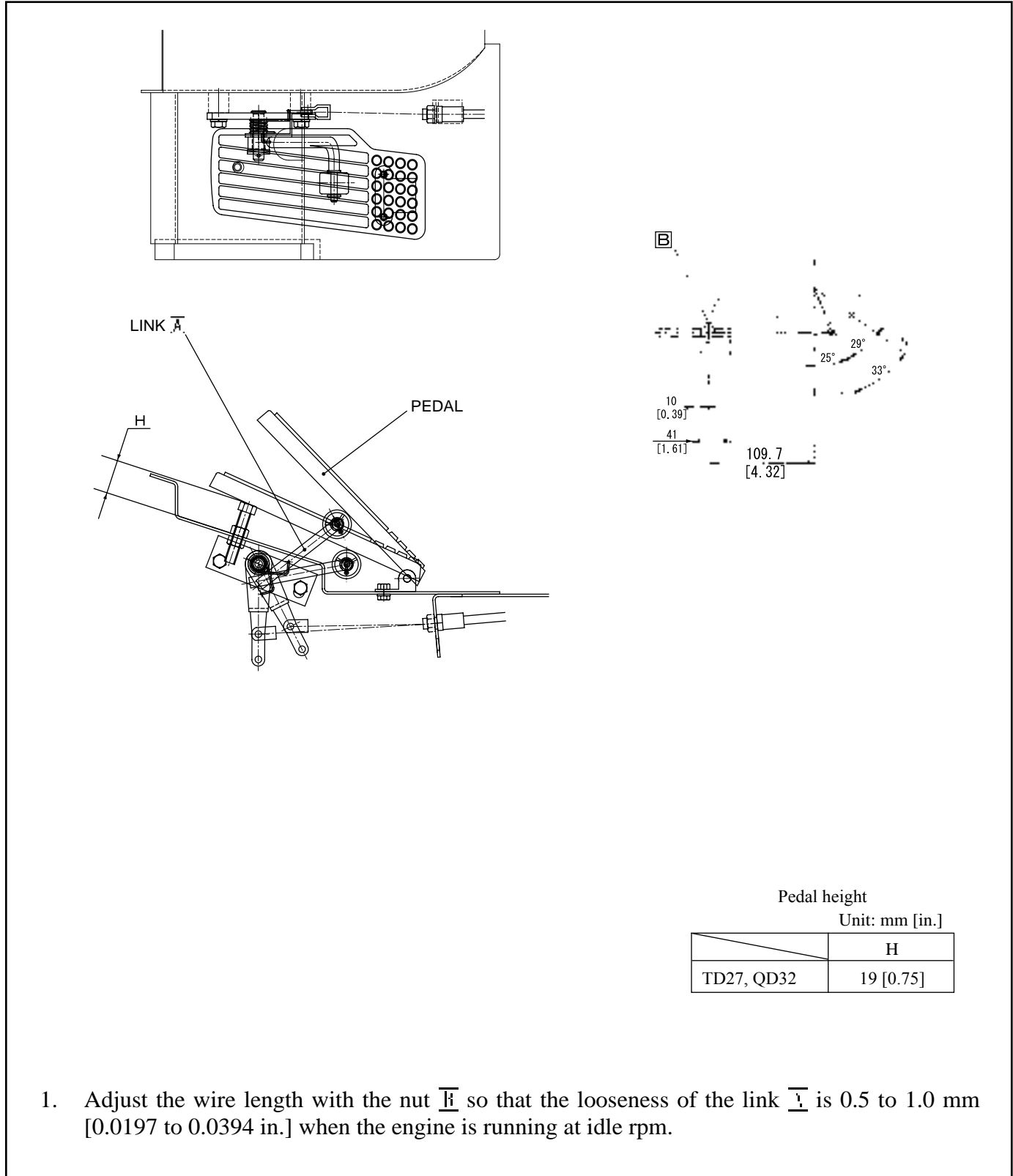

Fig. 1.26 Accelerator Pedal (Gasoline engine)

(2) Diesel engine

The accelerator pedal controls engine output. It is installed as shown in Figure 1.27.

The movement of the accelerator pedal is transmitted by way of a wire cable to the engine.



1. Adjust the wire length with the nut \bar{i} so that the looseness of the link \bar{y} is 0.5 to 1.0 mm [0.0197 to 0.0394 in.] when the engine is running at idle rpm.

Fig. 1.27 Accelerator Pedal (TD27, QD32)

1.1.6 AIR CLEANER

The air cleaner removes dust and dirt from the air to be supplied to the engine. It is located on top of the oil tank at the right side of the frame.

The outside air enters the air cleaner through the duct provided at the mounting part of the rear right pillar of the overhead guard.

Dust and other foreign matter is removed by the air cleaner element before being supplied to the engine.

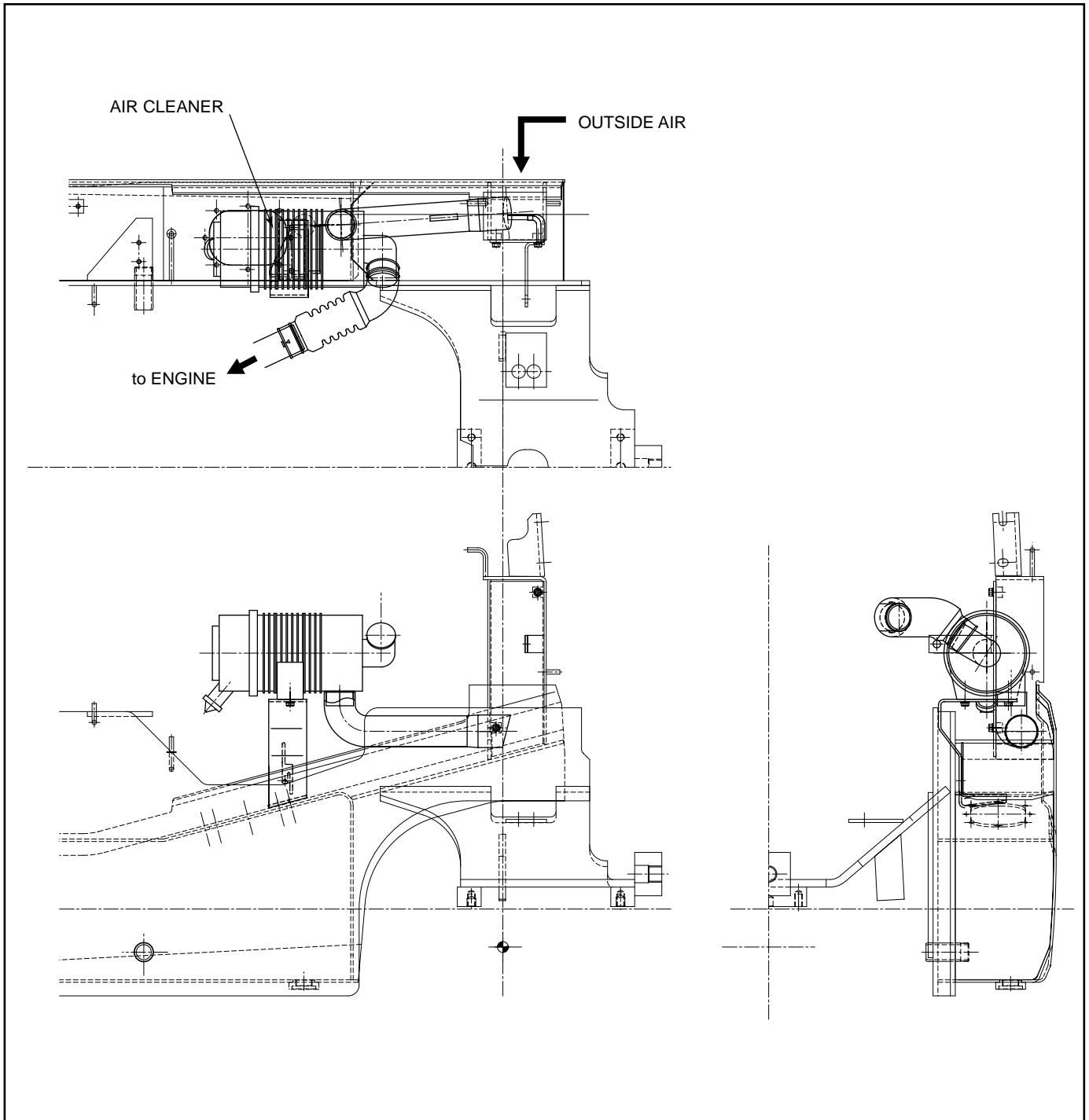

Fig. 1.28 Air Cleaner (Gas-powered, 1.5- to 1.8-ton trucks with K21 or K25)

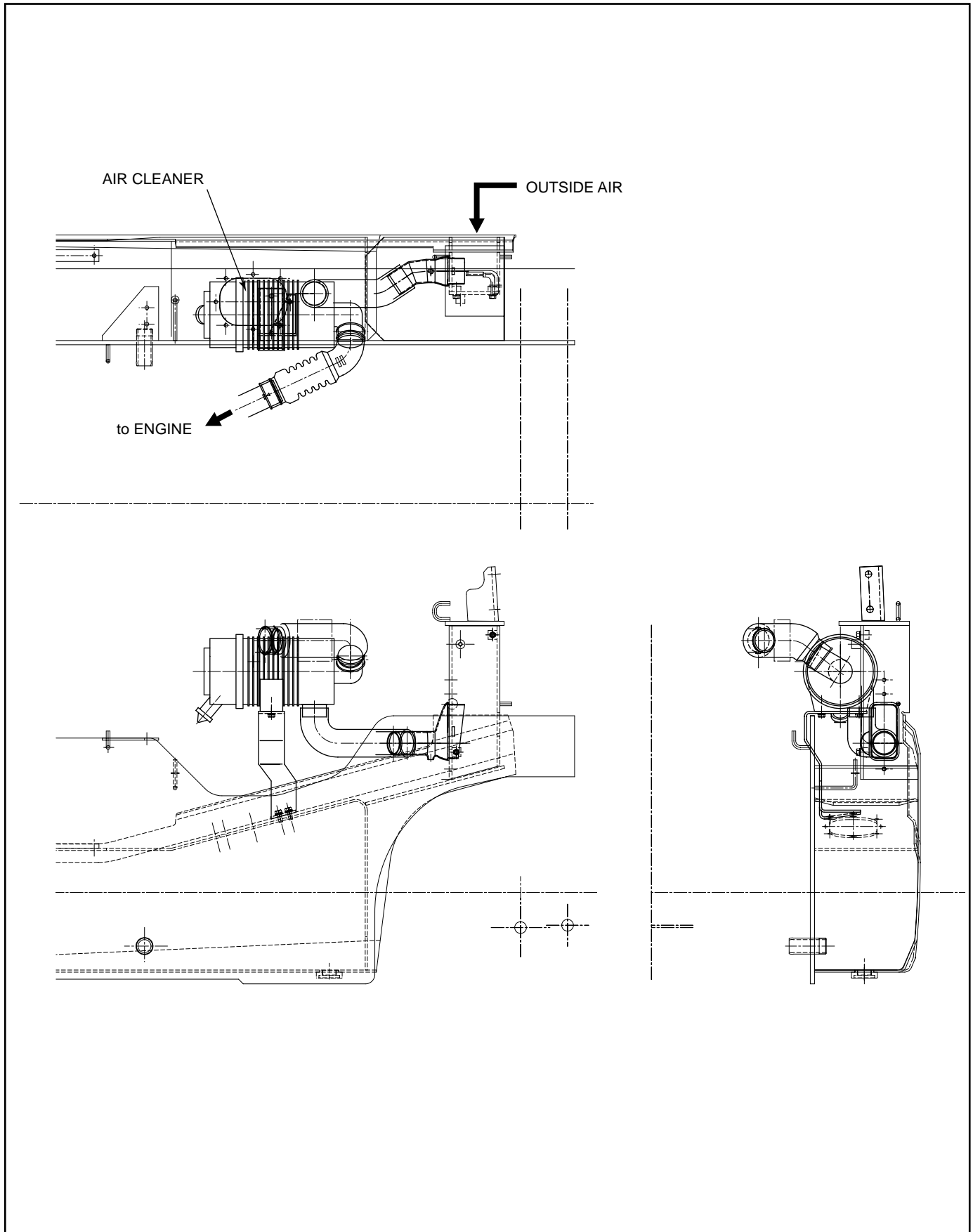

Fig. 1.29 Air Cleaner (Gas-powered, 2.0- to 3.5-ton trucks with K21 or K25)

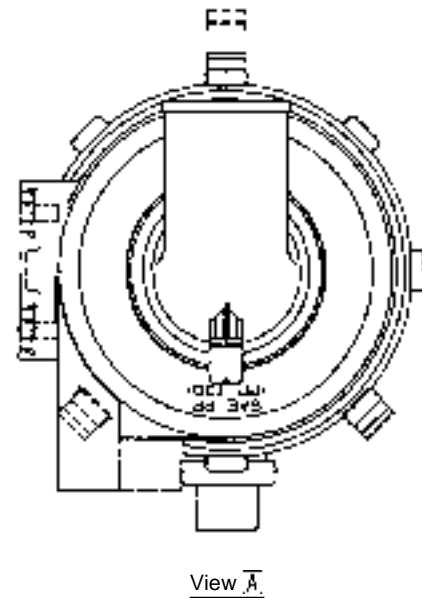
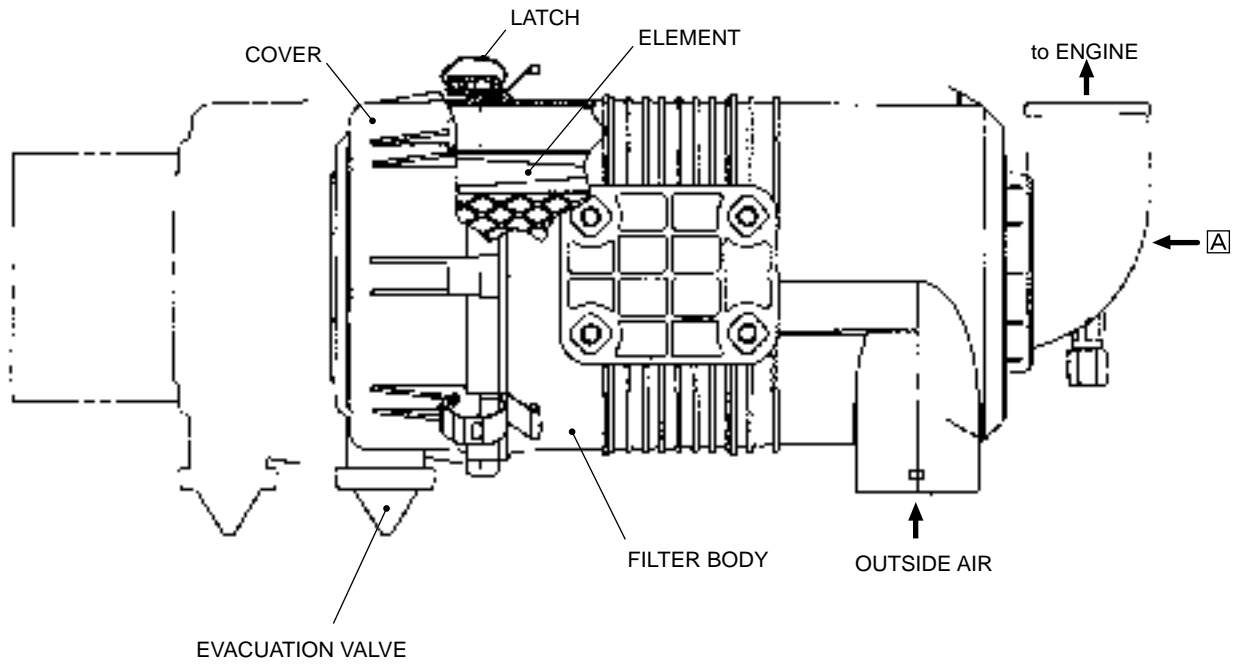

Fig. 1.30 Air Cleaner (Gas-powered trucks with K21 or K25)

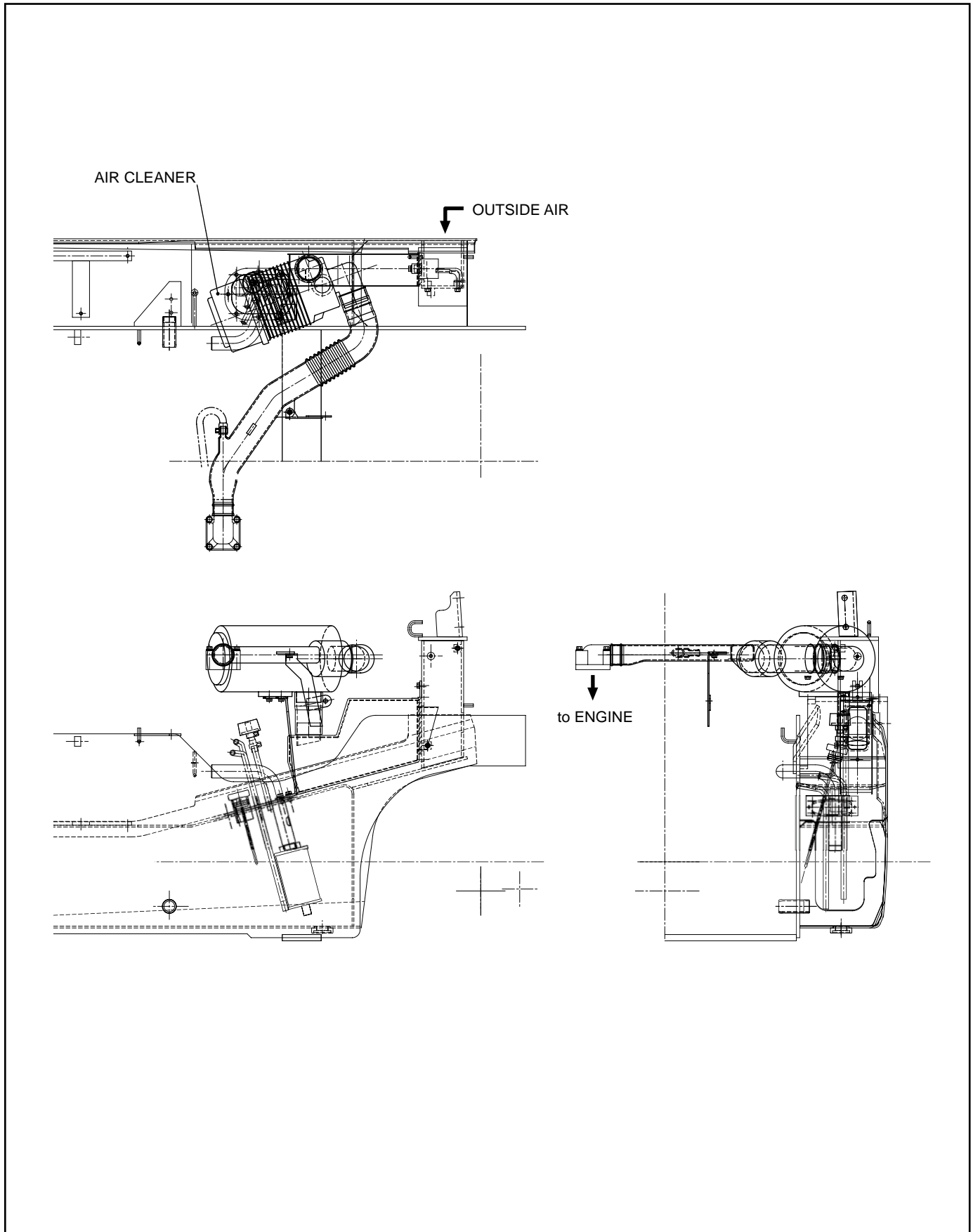

Fig. 1.31 Air Cleaner (Diesel-powered trucks with TD27, QD32)

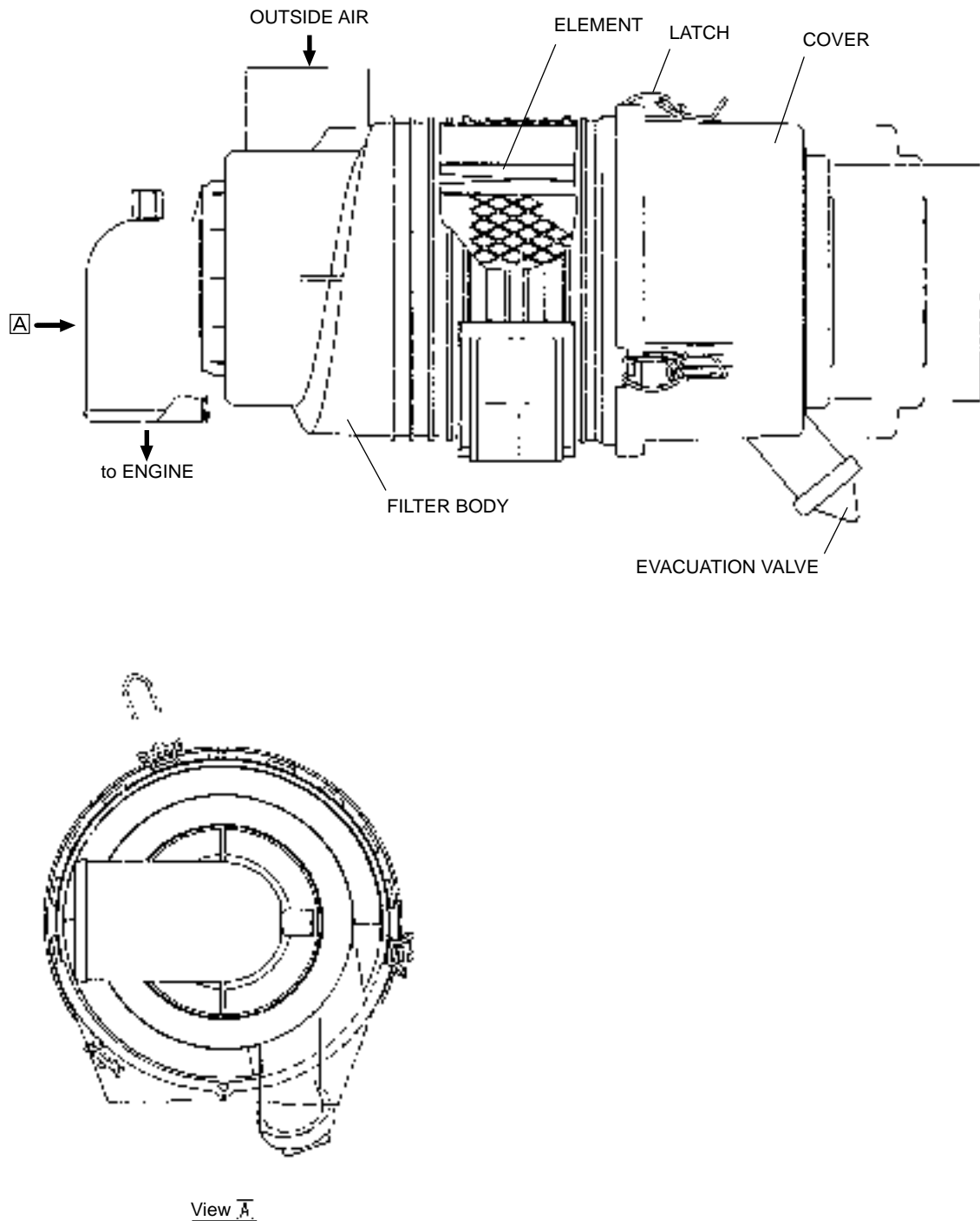

Fig. 1.32 Air Cleaner (Diesel-powered trucks with TD27, QD32)

■ **Air cleaner inspection and replacement**

- (1) Remove the air cleaner element.
- (2) Inspect the element for contamination and damage. If the element is dirty, clean it by blowing low-pressure air from inside to outside. If the element is damaged or clogged, replace it with a new one.
- (3) Clean the filter cover.

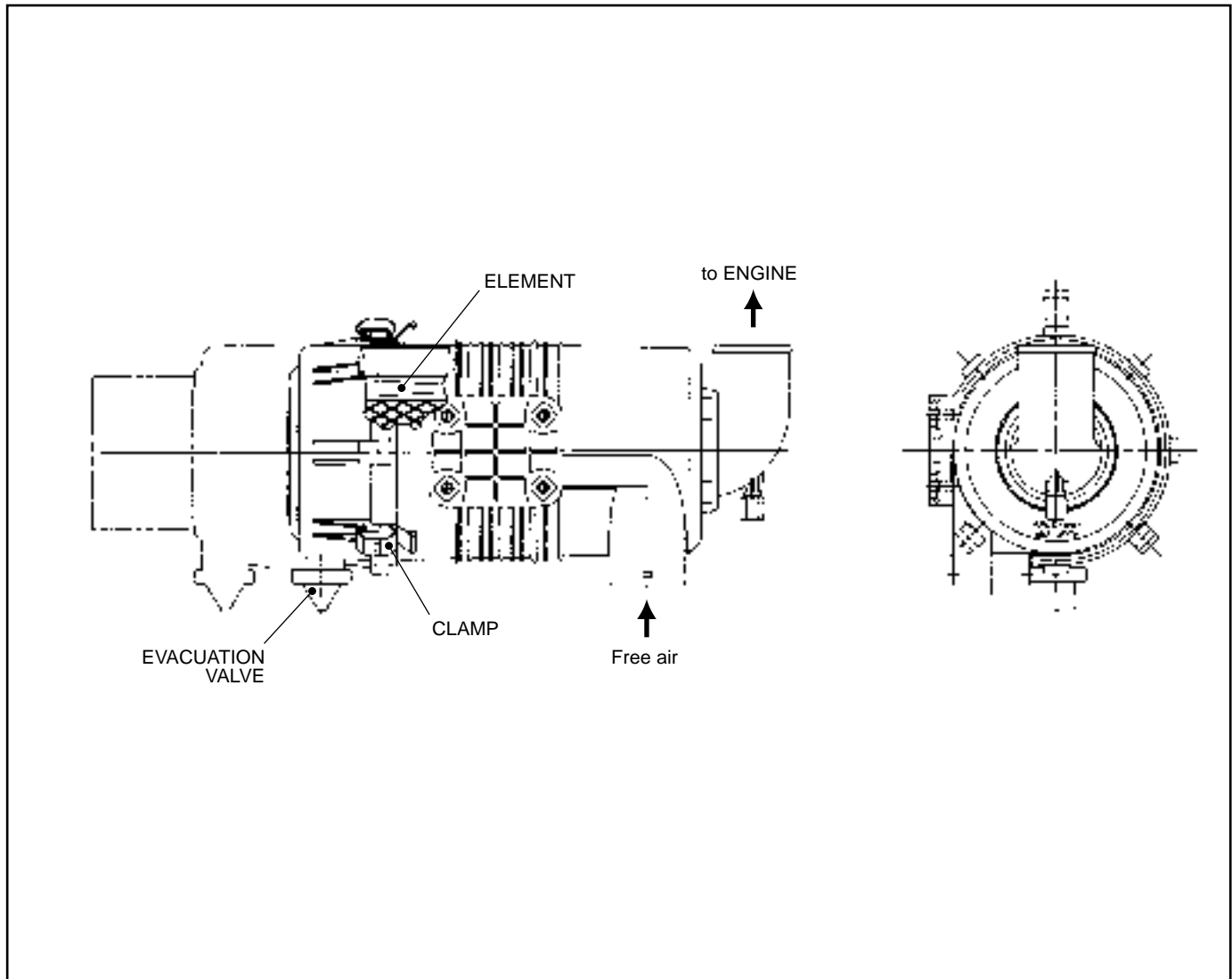

Fig. 1.33 Air Cleaner

⚠ Be careful not to touch the muffler and exhaust manifold since they are hot when the engine is running and for a while after it is shut off; otherwise you might burn your hand.

1.1.7 MUFFLER

The muffler helps reduce the sound of escaping gases of the engine, and it is provided between the radiator and the counterweight at the rear of the truck.

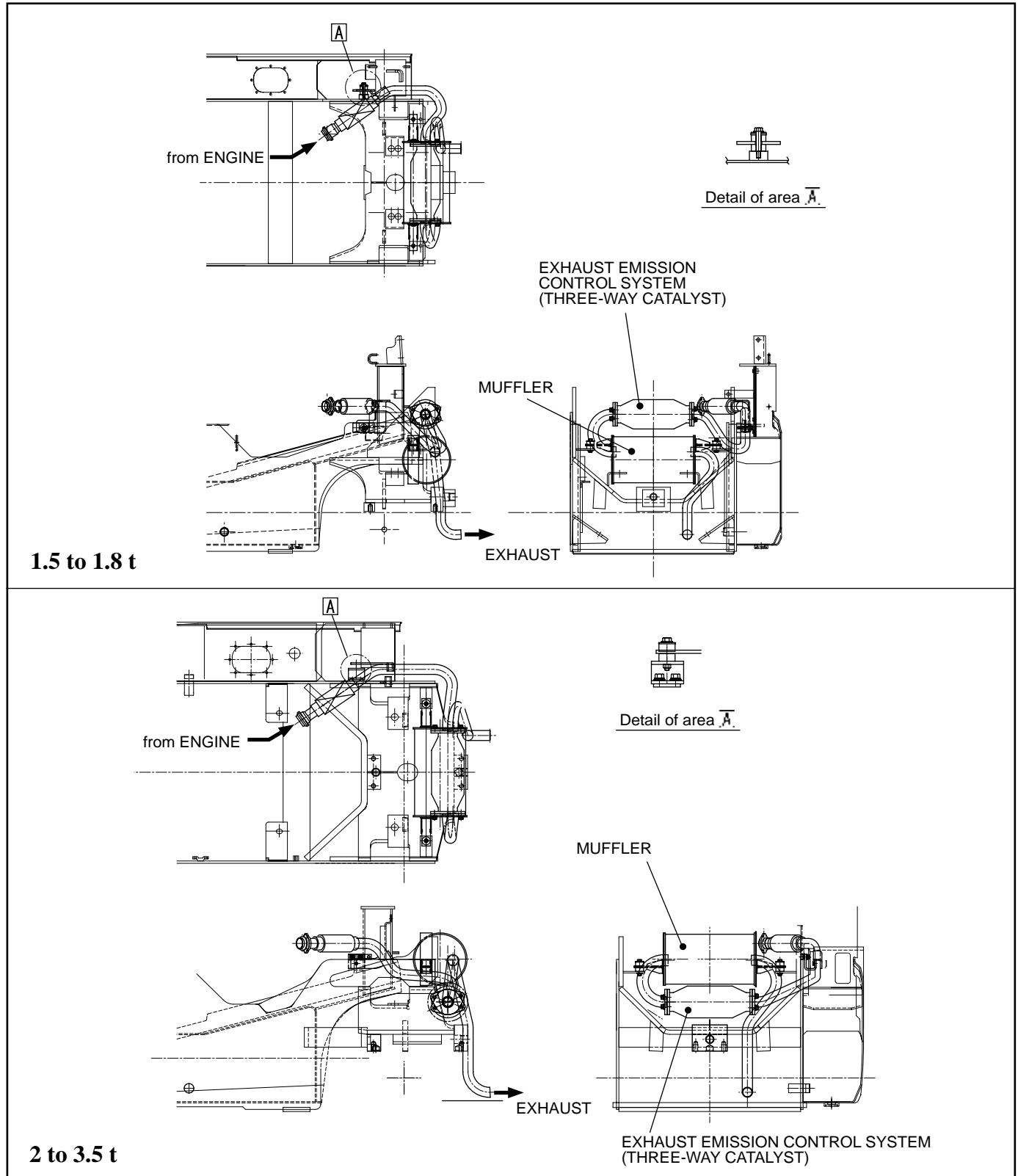

Fig. 1.34 Exhaust System (Gasoline Trucks)

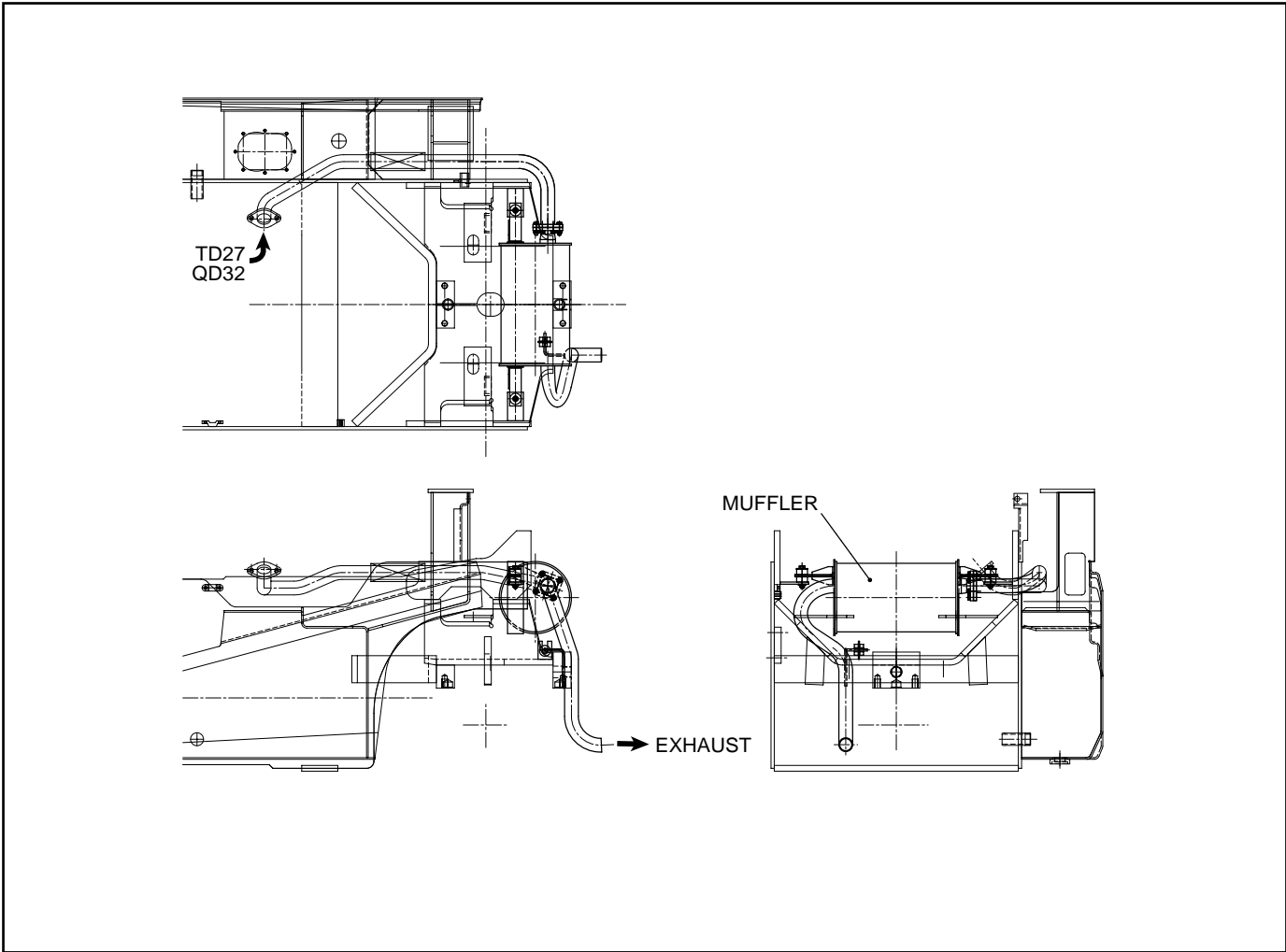

Fig. 1.35 Exhaust System (Diesel Trucks)

2. AUTOMATIC TRANSMISSION SYSTEM

Model	2N5-25
Speeds	1 fwd/rev
Torque converter	
Type	3-element, 1-stage, 2-phase type
Stall torque ratio	3
Charging oil pressure	0.39 – 0.69 MPa {3.98 – 7.04 kgf/cm ² } [56.6 – 100.1 psi]
Charging pump	
Type	Internal gear type
Discharge	15.93 cm ³ [0.97 in. ³]/rev
Transmission	
Type	Constant-mesh, power-shift type
Reduction ratio	1.638 for fwd, 1.674 for rev.
Clutch disc	
Dimensions	125 x 81 x 2.6 mm [4.92 x 3.19 x 0.102 in.]
Clutch oil pressure	1.08 – 1.47 MPa {11.01 – 15.0 kgf/cm ² } [156.6 – 213.2 psi]
Differential	
Reduction ratio	5.833
Weight	110 kg [242.5 lbs]
Oil capacity	9.0 liters [2.4 U.S. gal]
Oil to be used	SAE10W or equivalent

2.1 GENERAL DESCRIPTION

The automatic transmission system consists of a torque converter and a power-shift transmission as shown in Figures 2.1 and 2.2.

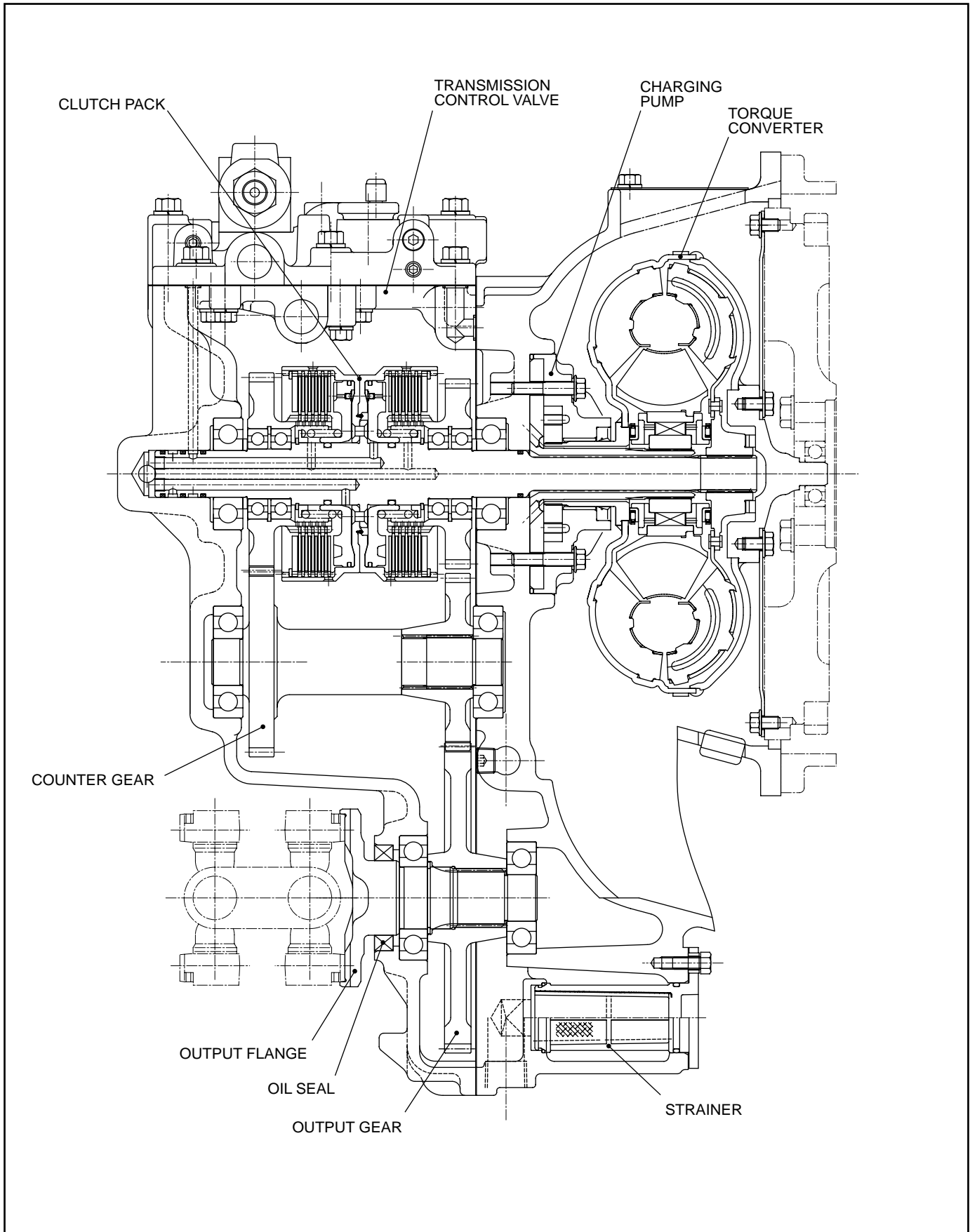

Fig. 2.1 Automatic Transmission System 1/2

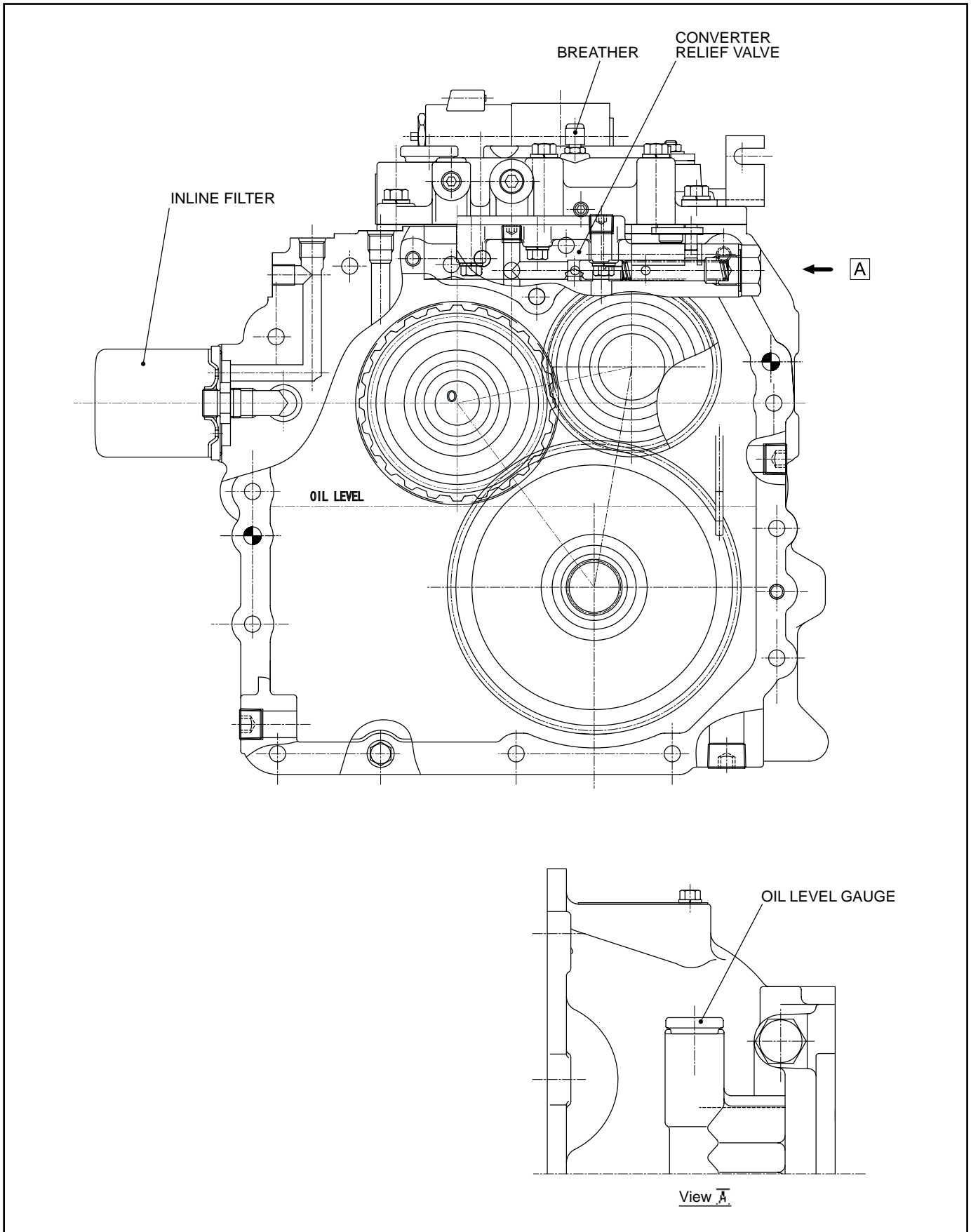

Fig. 2.2 Automatic Transmission System 2/2

2.1.1 TORQUE CONVERTER

The torque converter consists of a pump wheel, a turbine wheel, and a stator wheel, as shown in Figure 2.3.

As the engine is started, the pump wheel is driven and the fluid inside the pump wheel begins to be ejected along with the row of pump wheel vanes under centrifugal force, flowing into the row of turbine wheel vanes. The direction of fluid leaving the turbine wheel is changed by the stator wheel so that it may flow into the pump wheel at a proper angle. At this time, reaction torque pushing the stator is created so that the output torque exceeds the input torque by this reaction torque.

If the rotational speed of the turbine wheel increases and gets closer to the input rotational speed, the angle change in the fluid will become smaller and the output shaft torque will decrease, finally letting the fluid flow into the row of stator vanes in the reverse direction, causing reverse reaction torque.

As a result of this, the output shaft torque will become smaller than the input shaft torque. To prevent this from happening, the stator wheel is designed to rotate freely when reaction torque acts in the reverse direction. The output torque is kept equal to the input torque so that highly effective operation is ensured.

Since the phase of torque transmission is converted by the mechanical means, this type of torque conversion is called 2-phase type, which ensure smooth and effective operation.

The pump wheel of the torque converter is connected through the input plate to the engine flywheel, with area \bar{A} of the pump wheel boss driving the charging pump.

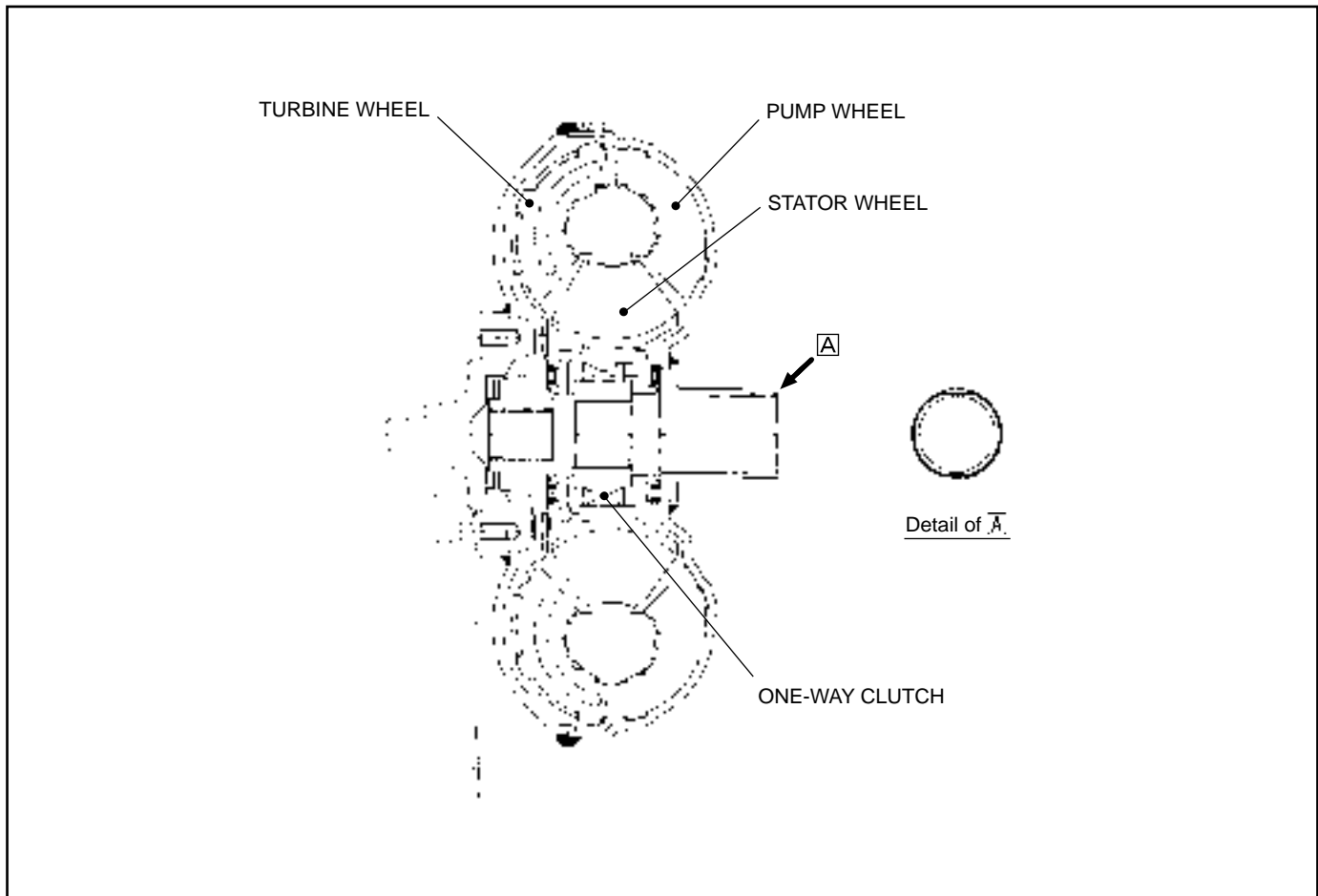

Fig. 2.3 Torque Converter

2.1.2 CHARGING PUMP

The charging pump consists of a drive gear, driven gear, a case, and a stator support as shown in Figure 2.4 and is incorporated into the torque converter housing.

The drive gear is driven by the pump wheel boss of the torque converter to pick up oil from the lower part of the transmission case and send it to the transmission and the torque converter.

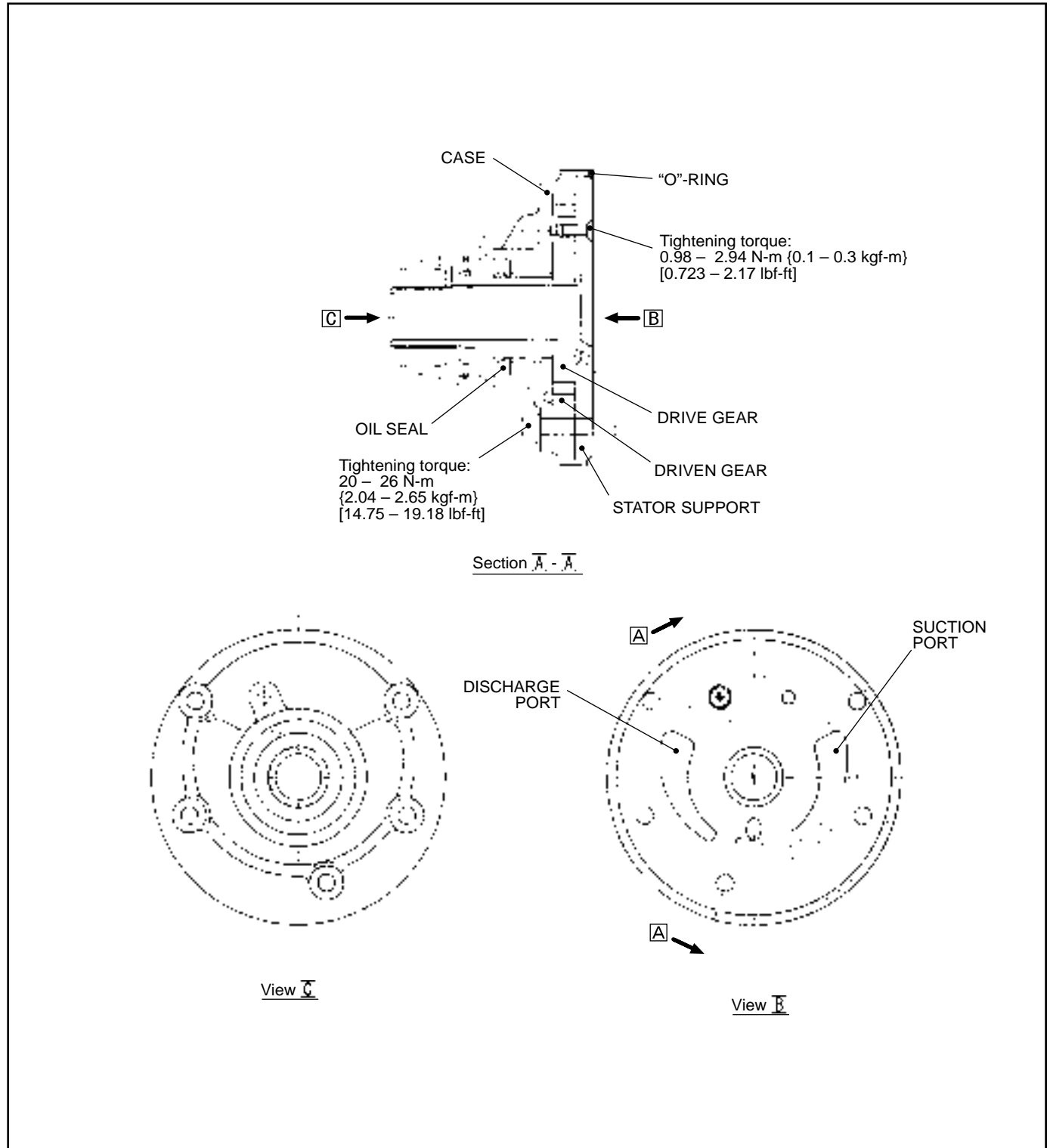

Fig. 2.4 Charging Pump

2.1.3 TRANSMISSION

The transmission is a power-shift type consisting of a clutch pack assembly, an output shaft, a reverse gear, and transmission control valve. (See Figures 2.1 and 2.2.)

(1) Clutch pack assembly

The clutch pack assembly consists of forward and reverse clutch packs, each of which consists primarily of a piston, a spring, clutch discs and a steel plate.

The piston is always forced against the far end of the drum by the spring. When the oil pressure is applied, the piston locks up the inner and outer discs.

The clutch lock-up oil is supplied through the groove in the clutch shaft and the lubrication oil is fed through the oil hole in one end of the shaft.

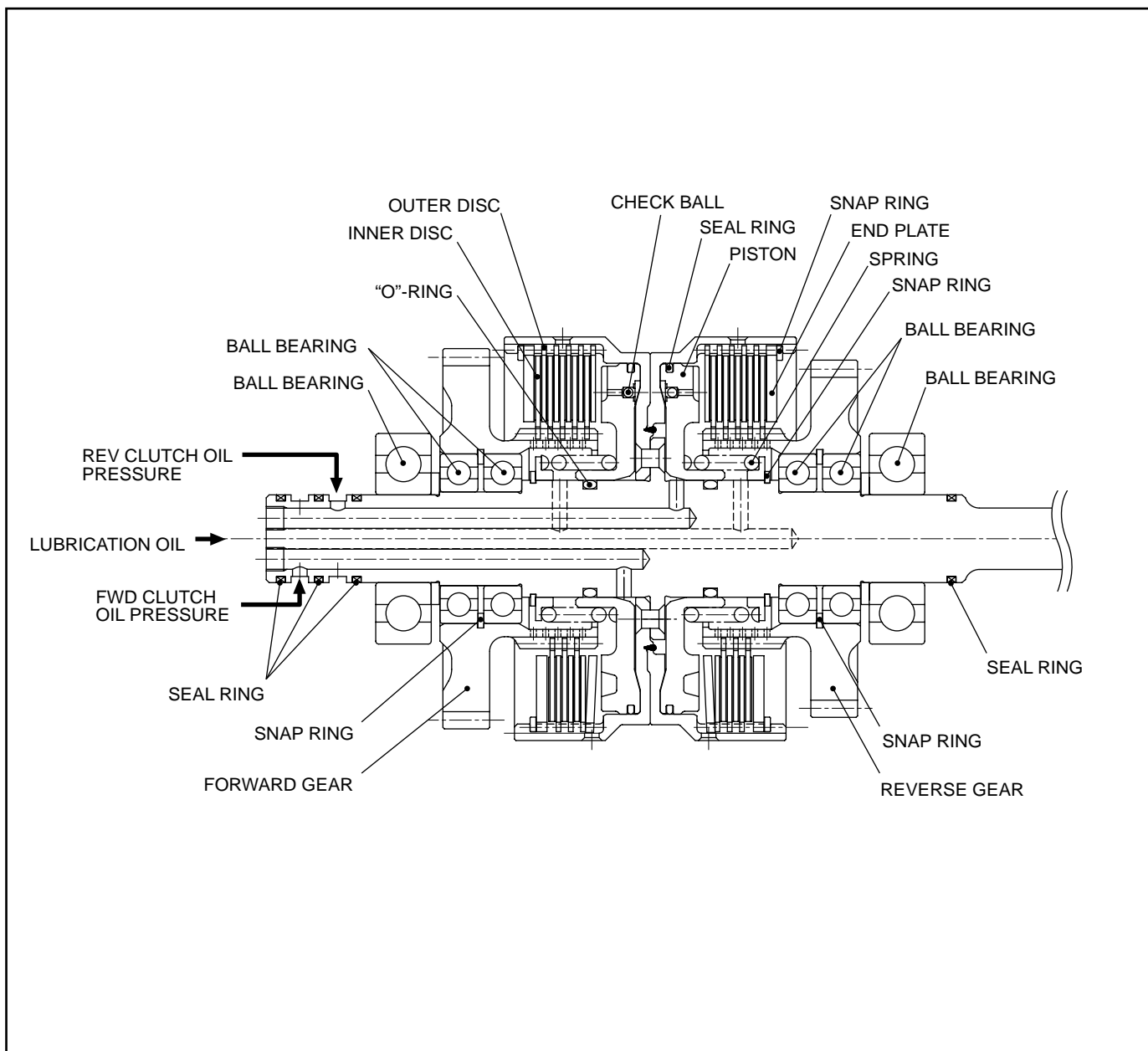

Fig. 2.5 Clutch Pack Assembly

(2) Transmission oil pressure circuit

As the engine is started and the charging pump is driven, oil is picked up from the lower part of the transmission case to flow through the strainer to the main relief valve where it is regulated to the specified clutch oil pressure.

The oil relieved from the main relief valve flows, passing through the torque converter, oil cooler, and inline filter, to some parts of the truck for cooling and lubrication before returning into the transmission case.

The oil pressure inside the torque converter is controlled to a specified value by the torque converter relief valve.

I In neutral

With the solenoid valve in neutral, the oil is blocked by the solenoid valve and therefore all the oil supplied from the charging pump flows to the torque converter.

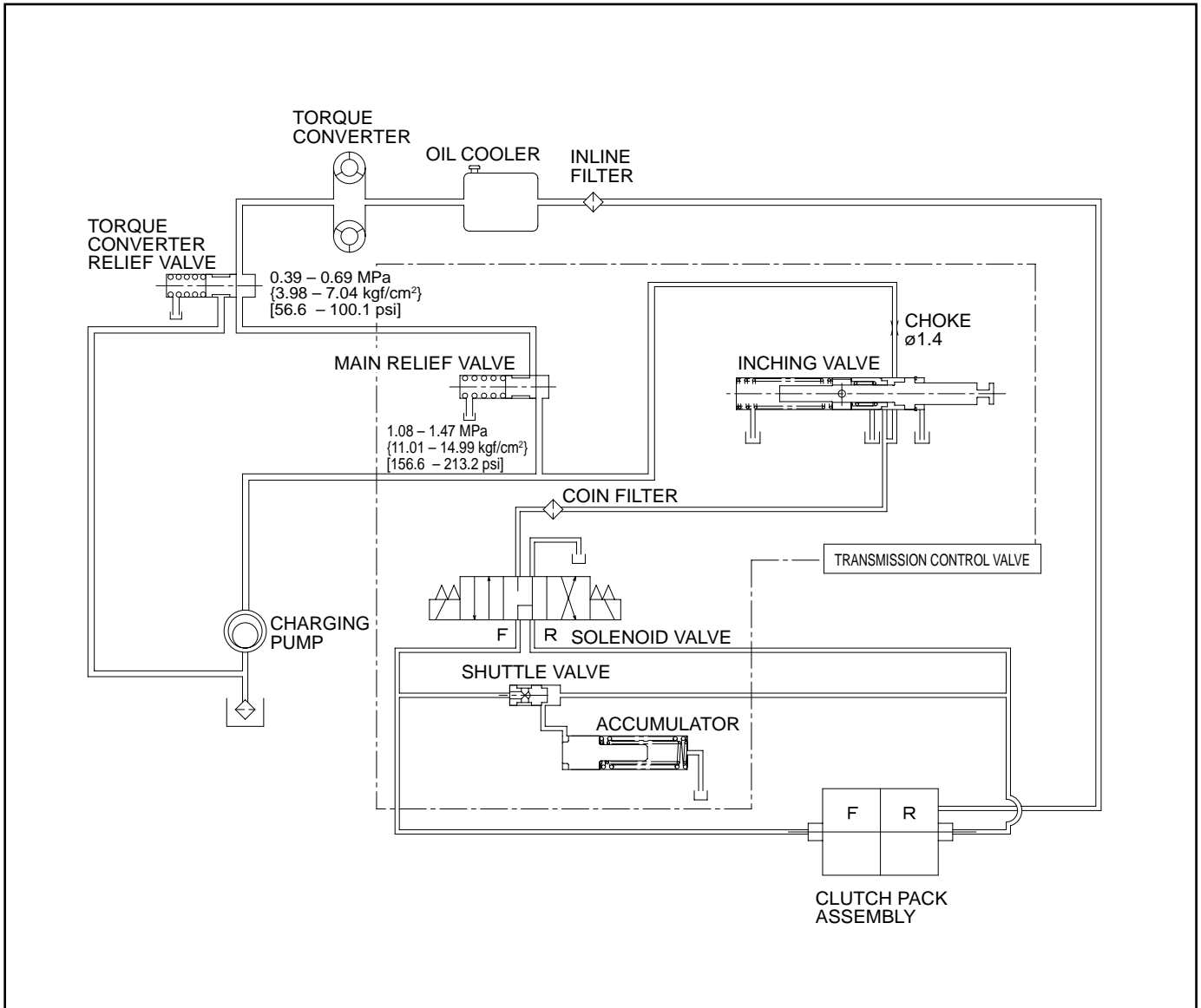

Fig. 2.6 Transmission Oil Pressure Circuit Diagram (in neutral)

2 In forward gear

As the solenoid valve is switch to the forward position, the oil flows to the forward clutch pack while the shuttle valve moves to the right to allow the oil to flow also to the accumulator. Until the accumulator is filled with oil, the clutch oil pressure increases gradually and the clutch lock-up pressure is weak. Once the accumulator is filled with oil, however, the clutch lock-up oil pressure rises rapidly to the specified value to lock up the forward clutch pack completely.

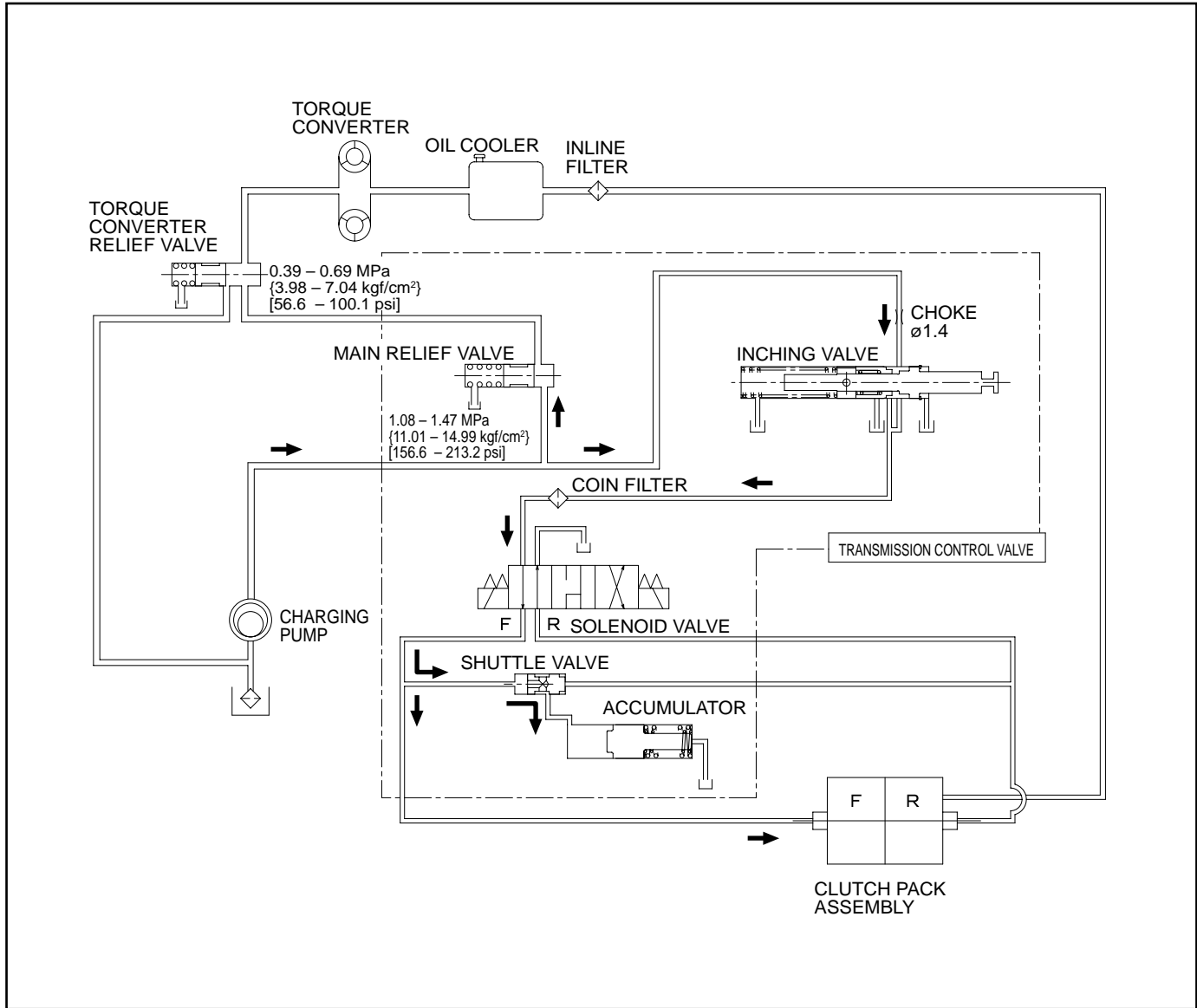

Fig. 2.7 Transmission Oil Pressure Circuit Diagram (in forward gear)

⌘ In reverse gear

When the solenoid valve is switch to the reverse position, the oil flows to the reverse clutch pack while the shuttle valve moves to the left to allow the oil to flow also to the accumulator. Until the accumulator is filled with oil, the clutch oil pressure increases gradually and the clutch lock-up pressure is weak. Once the accumulator is filled with oil, however, the clutch lock-up oil pressure rises rapidly to the specified value to lock up the reverse clutch pack completely.

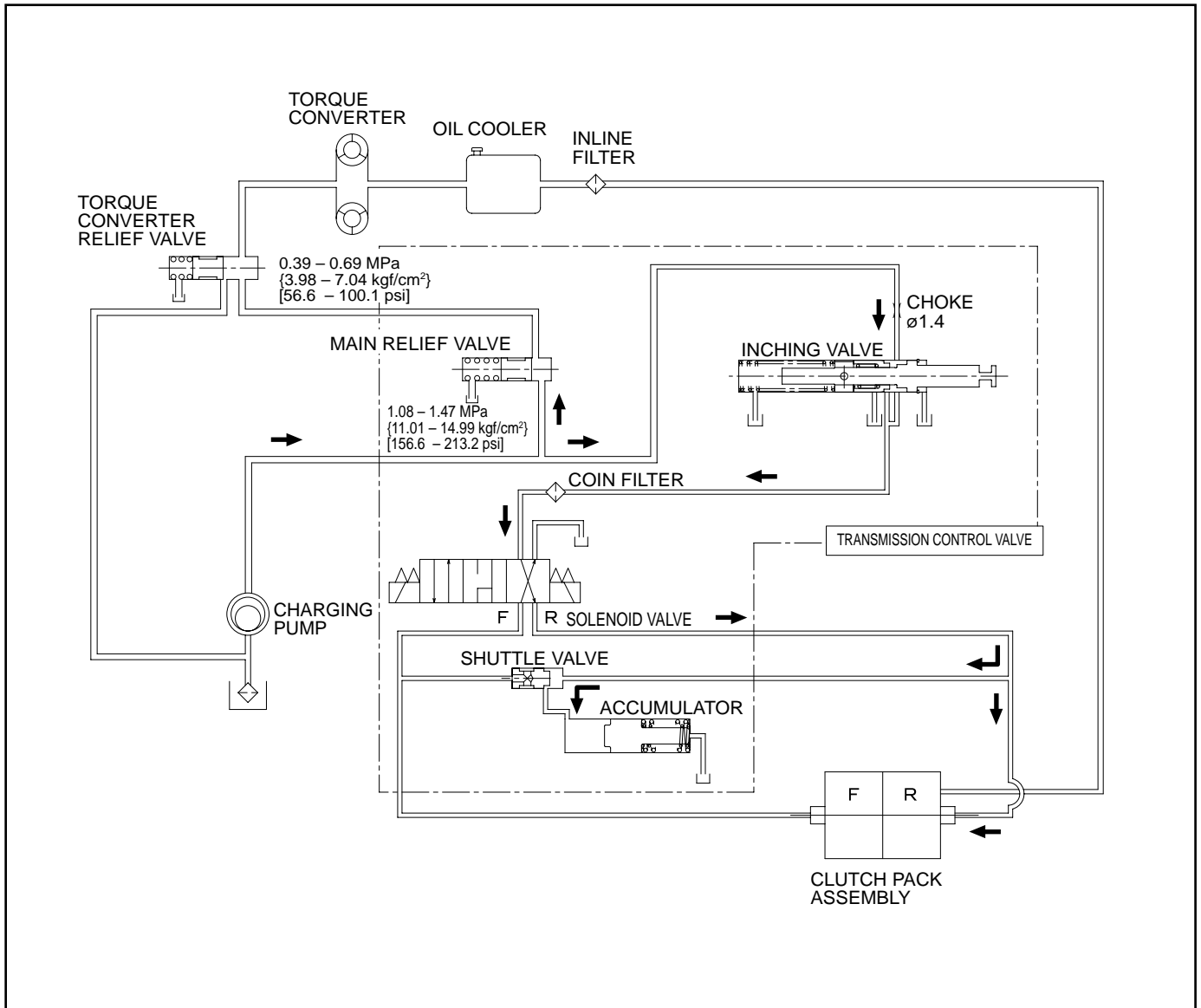

Fig. 2.8 Transmission Oil Pressure Circuit Diagram (in reverse gear)

; Inching

When the inching spool is pushed in, the oil flowing to the clutch pack assembly is drained through the inching spool piston. In addition, the oil returning from the clutch pack assembly is also drained.

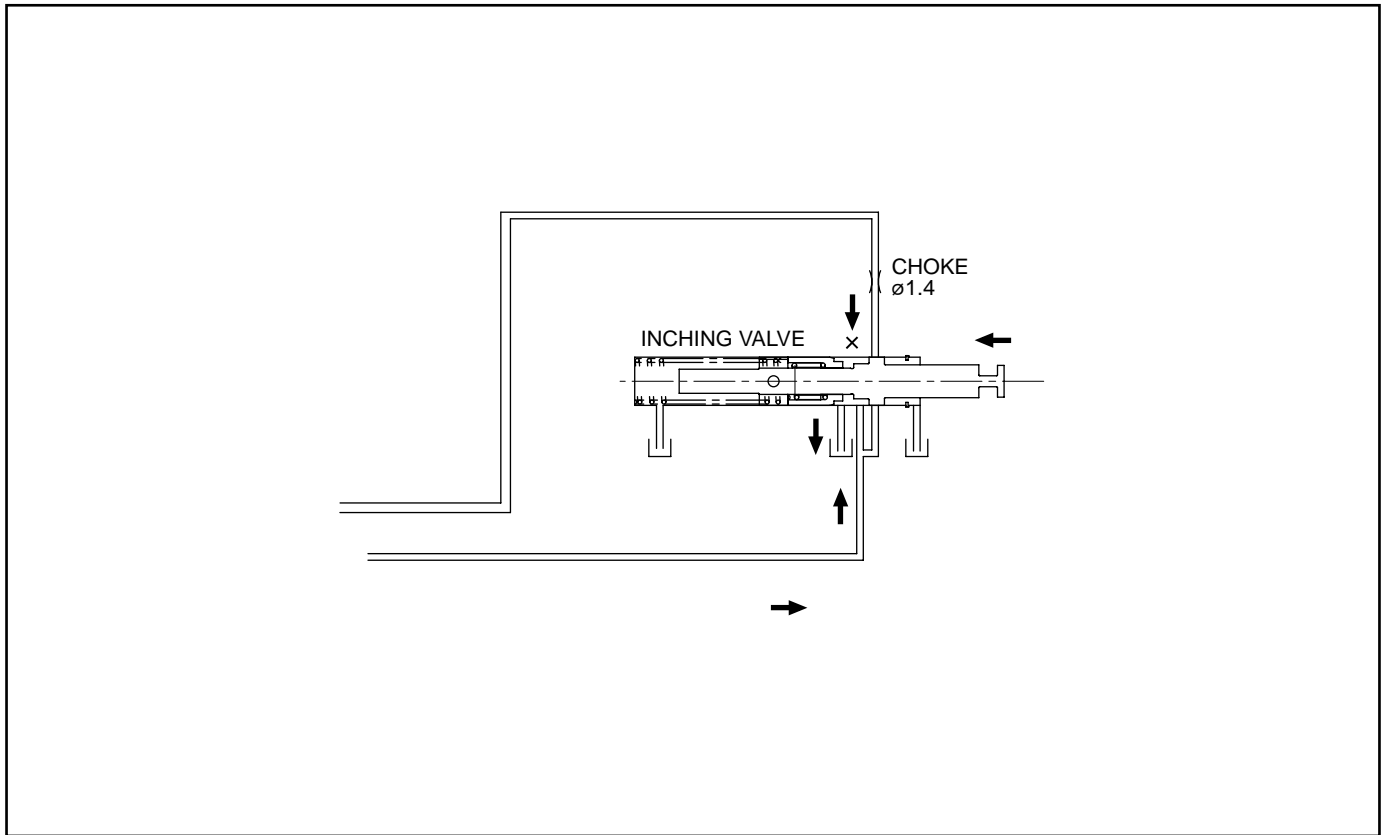

Fig. 2.9 Transmission Oil Pressure Circuit Diagram (during inching)

2.1.4 TRANSMISSION CONTROL VALVE

The transmission control valve consists of an inching valve, a regulator valve, and an accumulator, as shown in Figure 2.10. It is attached to the transmission case cover.

The inching valve spool is controlled by the lever installed on the case cover. The lever is in turn controlled through the cable connected to the left-side brake pedal. As the left-side brake pedal is pressed, the cable is pulled so that the lever pushes the inching valve spool.

The case cover has a solenoid valve which switches over the directions of travel.

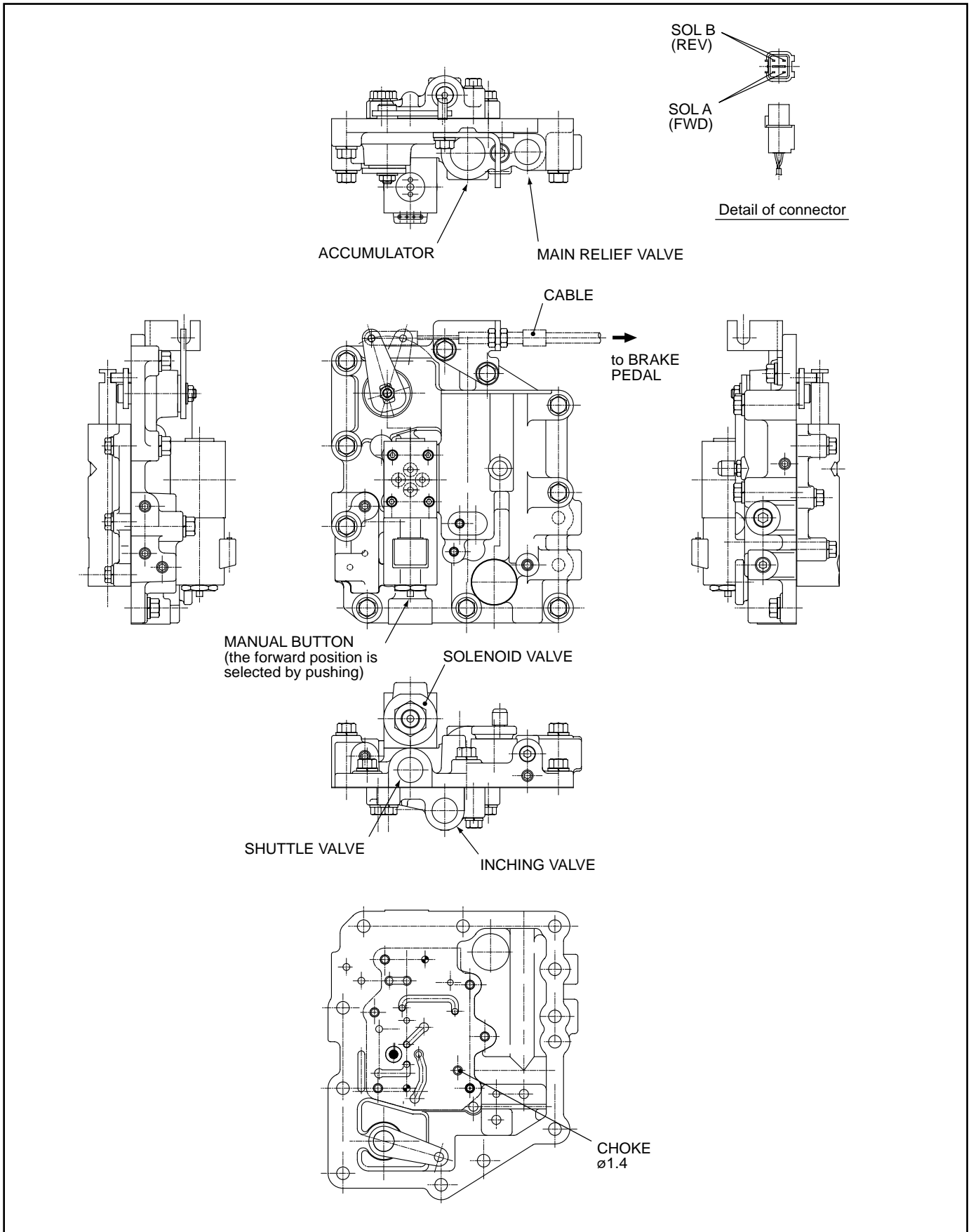
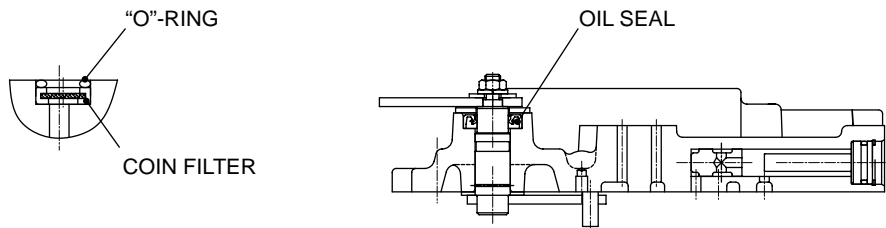
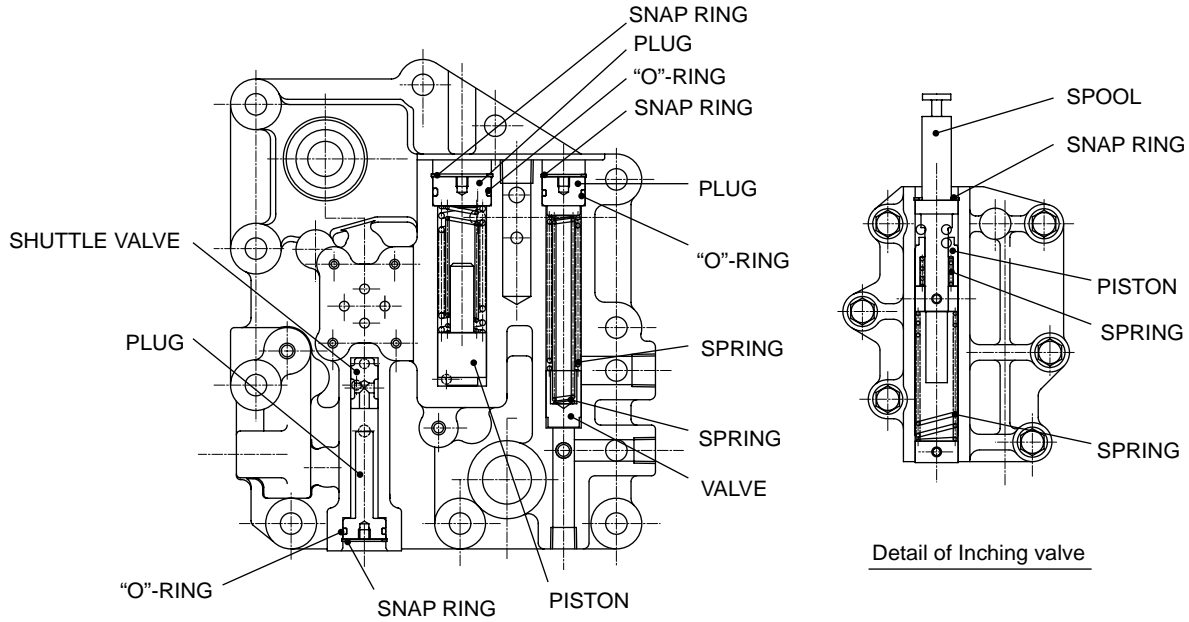

Fig. 2.10 Transmission Control Valve (1/2)



Detail of lever

Fig. 2.11 Transmission Control Valve (2/2)

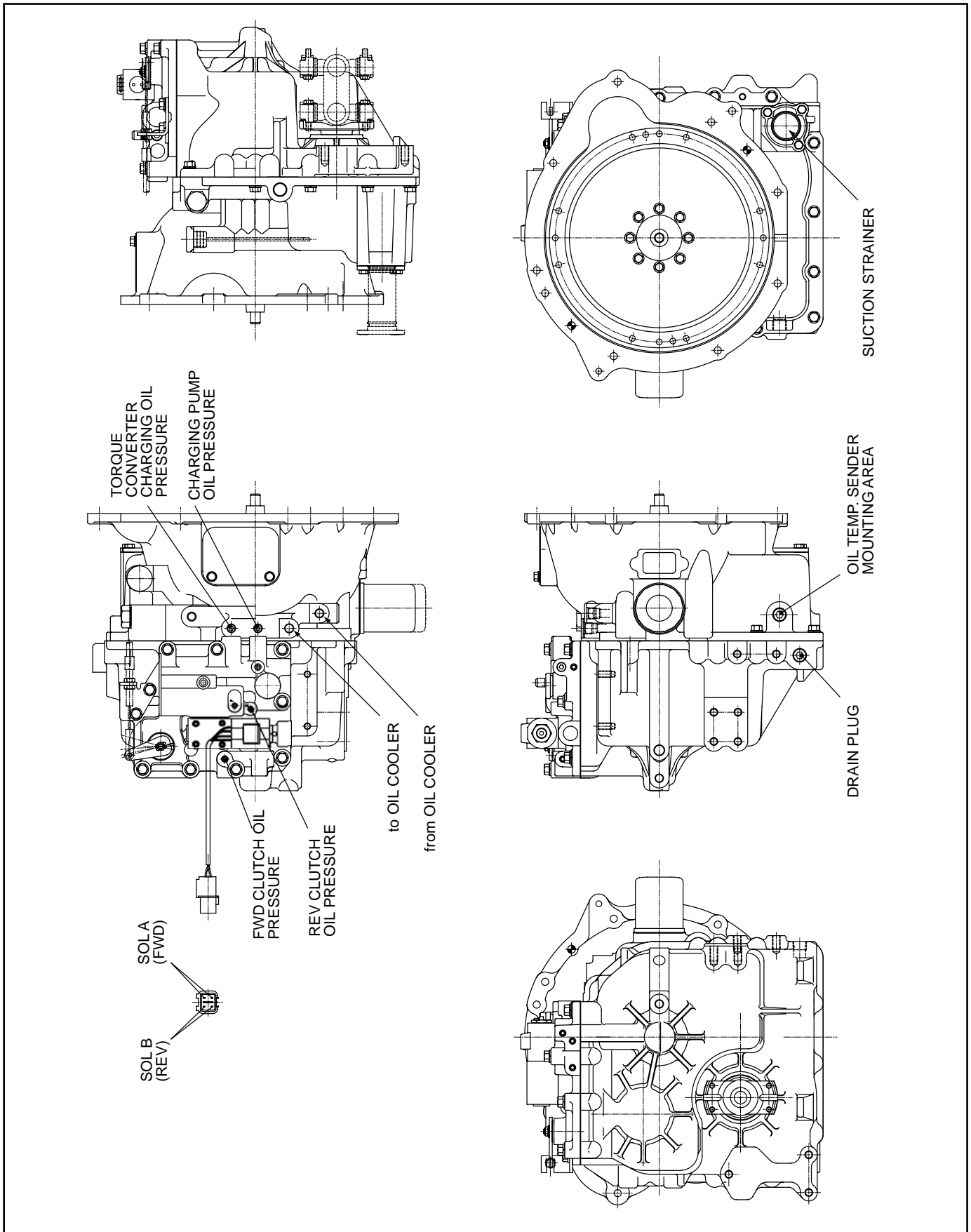

Fig. 2.12 Oil Pressure Check Ports

3. DRIVE AXLE

Truck Model		FG20 _{T3} FD20 _{T3}	FG30 _{T3}	
Item	FHG15 _{T3} FHG18 _{T3} FHD15 _{T3} FHD18 _{T3}	FHG20 _{T3} FHD20 _{T3A} FG25 _{T3} FD25 _{T3} FHG25 _{T3} FHD25 _{T3A}	FHG30 _{T3} FD30 _{T3} FHD30 _{T3A}	FG35 _{T3S} FD35 _{T3S}
Type	Full-floating type	,	,	,
Wheel				
Size	2-6.50-10-10PR(I)	2-7.00-12-12PR(I)	2-28x9-15-12PR(I)	2-250-15-16PR(2)
Tread pattern	J-LUG	,	,	,
Rim				
Type	Split type (1.5 t) Disc type (1.8 t)	Split type	Disc type	,
Size	5.00F x 10DT (1.5 t) 5.00F x 10TB (1.8 t)	5.00S x 12DT	7.00T x 15	,
Tire inflation pressure	690 kPa [100 psi]	,	,	850 kPa [123 psi]

3.1 GENERAL DESCRIPTION

The drive axle has a construction as shown in Figures 3.1 and 3.2 and is mounted on the front area of the frame.

It has a wheel hub and a wheel brake at its each spindle end and an axle shaft running through its center. The wheel hub is provided with a brake drum, which is installed on the spindle through two tapered roller bearings. The two tapered roller bearings have oil seals to prevent grease inside from oozing out and water from entering the brake unit.

At the center of the housing is a differential which transmits the power from the transmission to the right and left wheels.

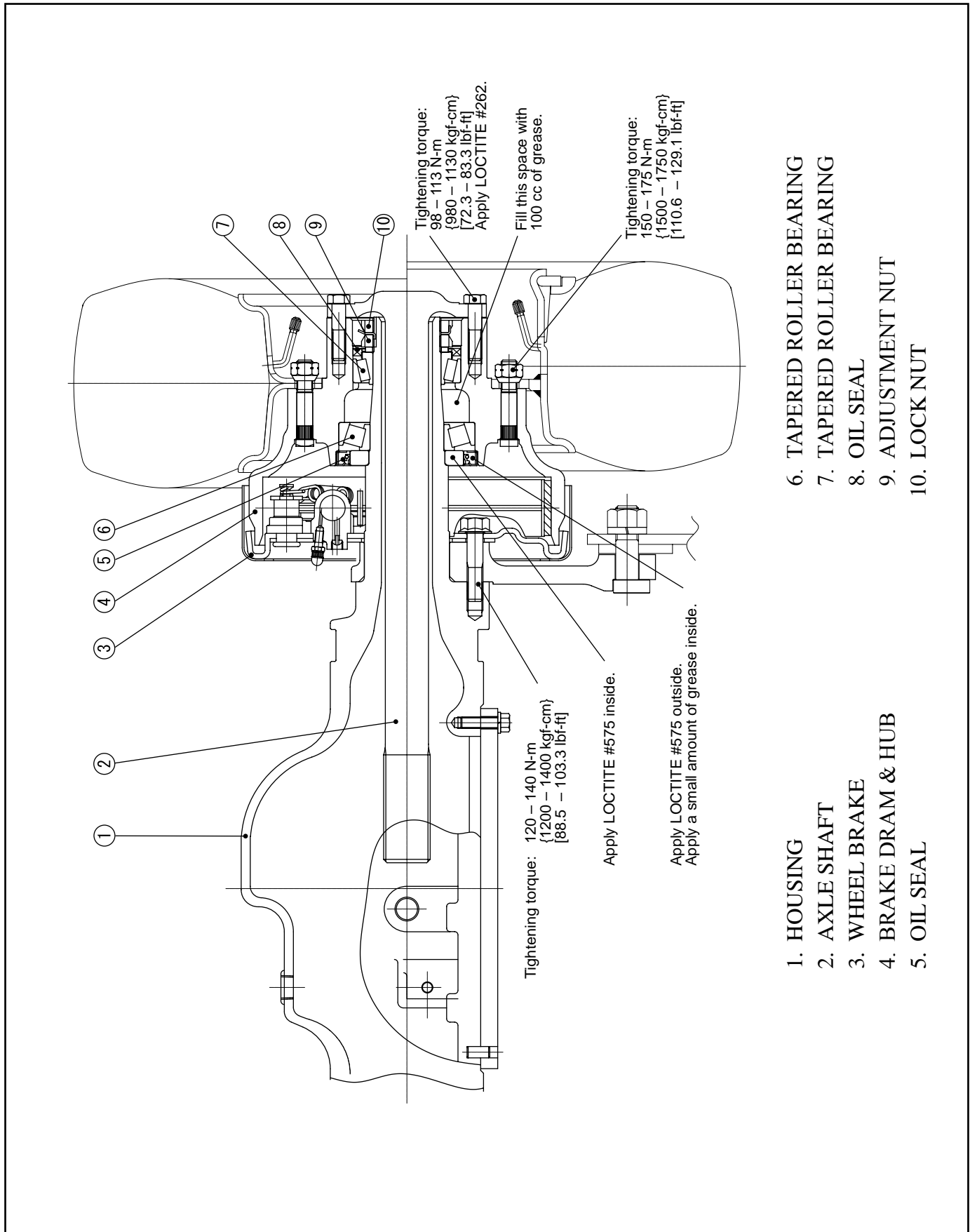

Fig. 3.1 Drive Axle (Trucks with capacities from 1.5 to 1.8 tons)

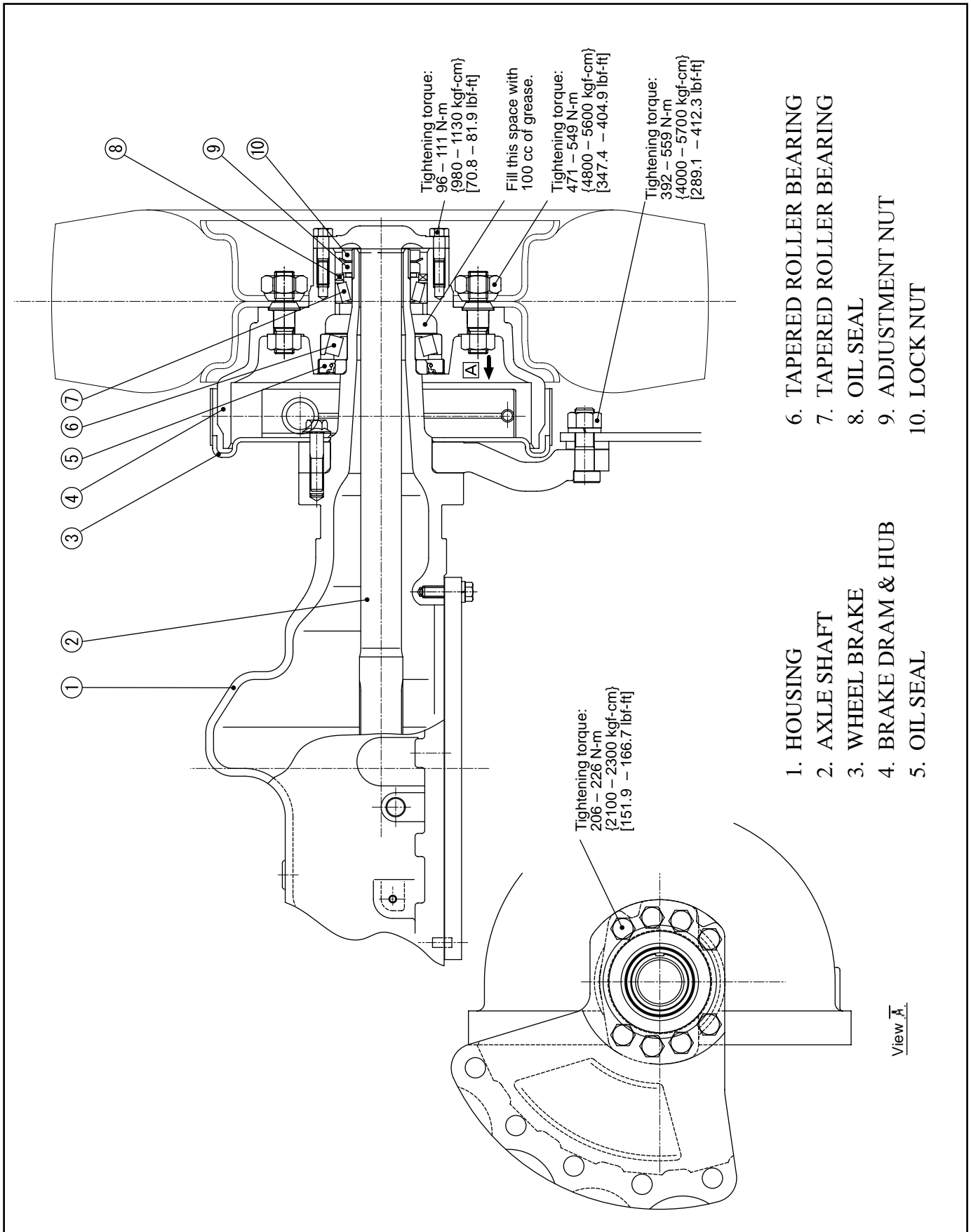

Fig. 3.2 Drive Axle (Trucks with capacities from 2.0 to 2.5 tons)

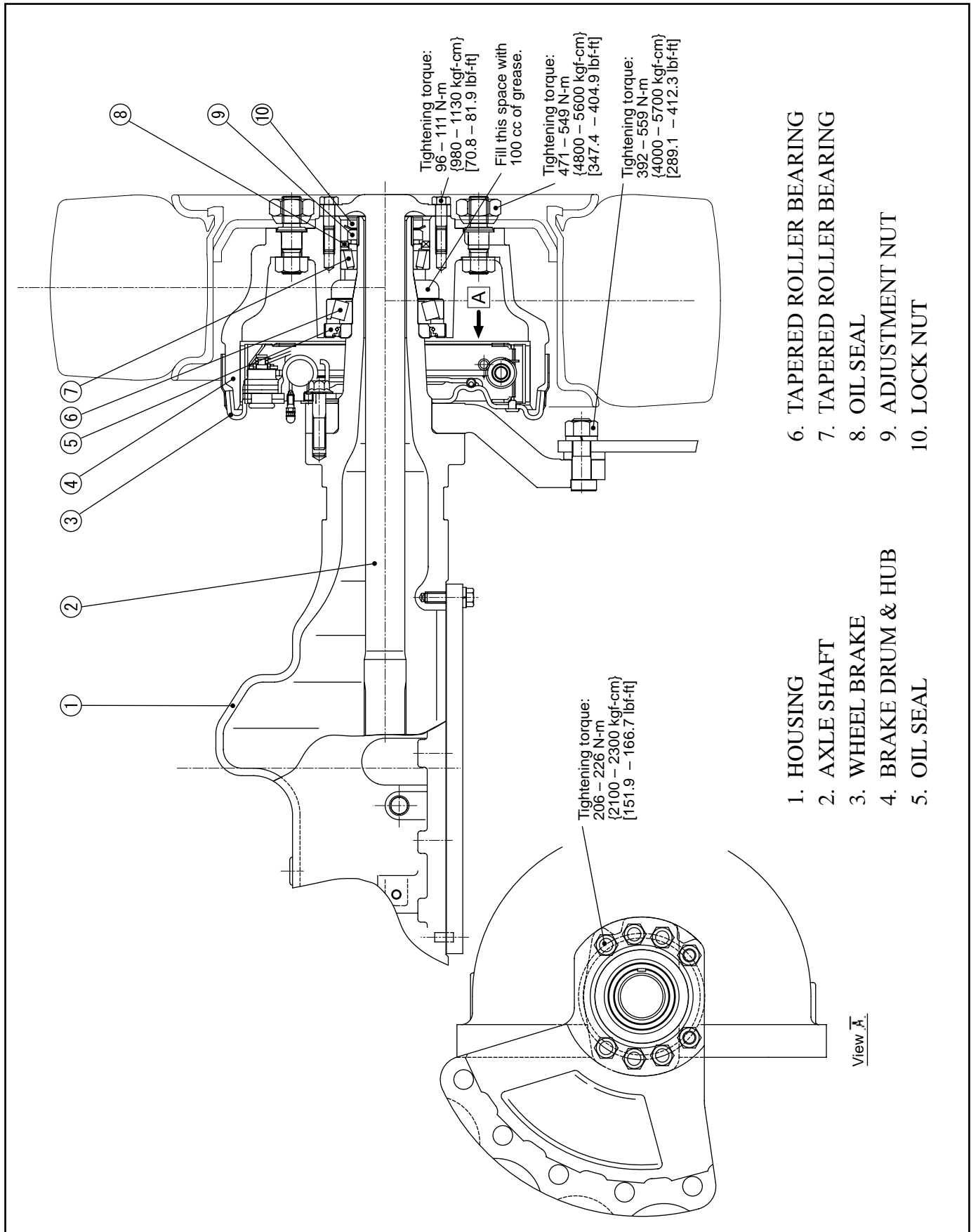

Fig. 3.3 Drive Axle (Trucks with a capacity of 3.0 tons)

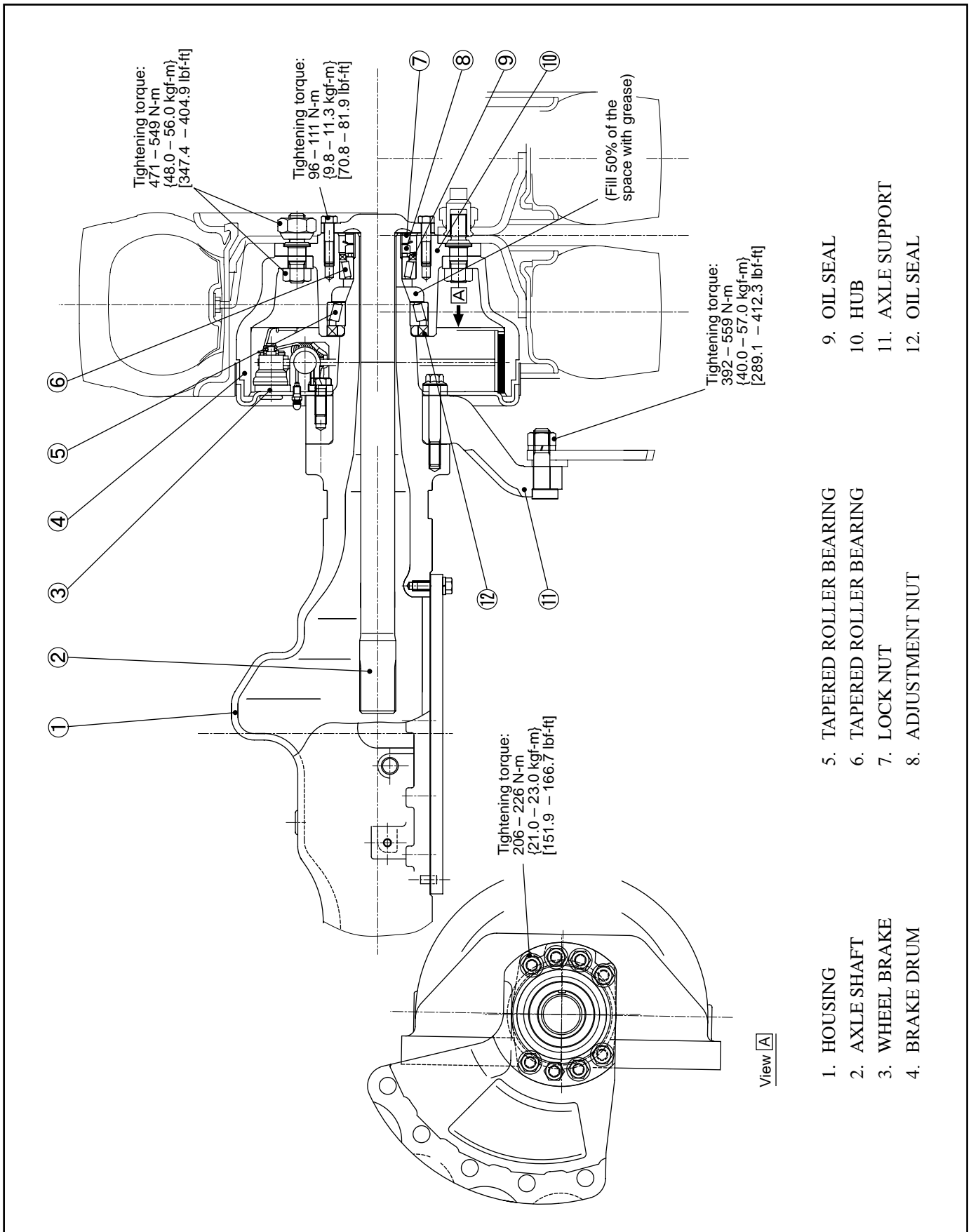

Fig. 3.4 Drive Axle (Trucks with a capacity of 3.5 tons)

Wheel hub installation procedure

- (1) Fill the space \bar{A} in the wheel hub with approximate 100 cc of grease and install the wheel hub on the spindle.
- (2) Tighten the adjustment nut to about 9.8 N-m {1 kgf-m} [7.2 lbf-ft] torque and back it off 1/2 of a turn.
- (3) Set a spring balance on the stud bolt and adjust the hub starting torque for the specified value, gradually tightening the adjustment nut.

Starting force: 49 – 147.1 N {5 – 15 kgf}
[11 – 33.1 lbf]

- (4) Install the lock washer and lock nut and secure the lock nut by bending the tang on the lock washer.

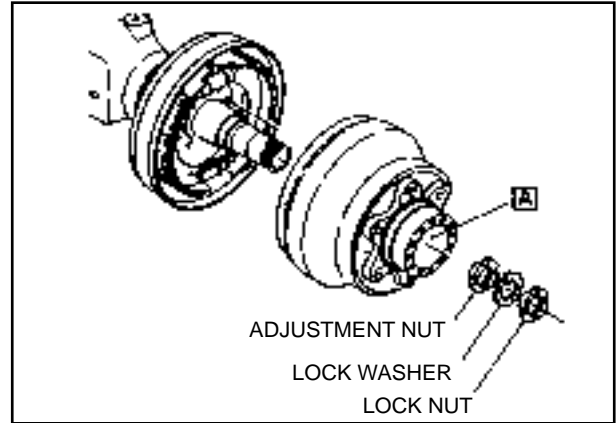

Fig. 3.5 Filling Grease

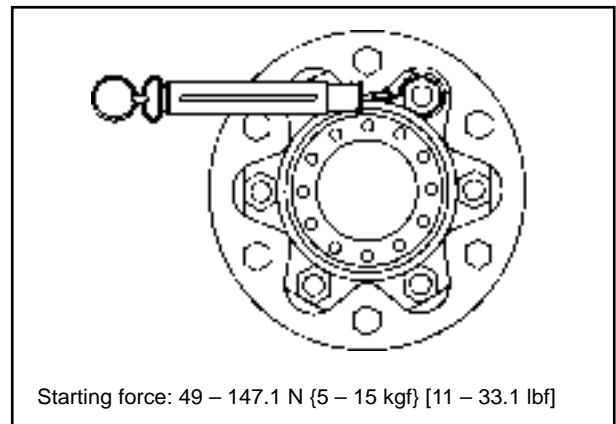

Fig. 3.6 Measuring Starting Force

- (5) Assembling wheels

Put a tube and flap in a tire and assemble the rims, observing the following conditions:

Note: 1. The air valve should be pointed outward, being matched with the rim notch.

2. The rim assembling bolts should be installed with their heads pointing the outside of the truck.

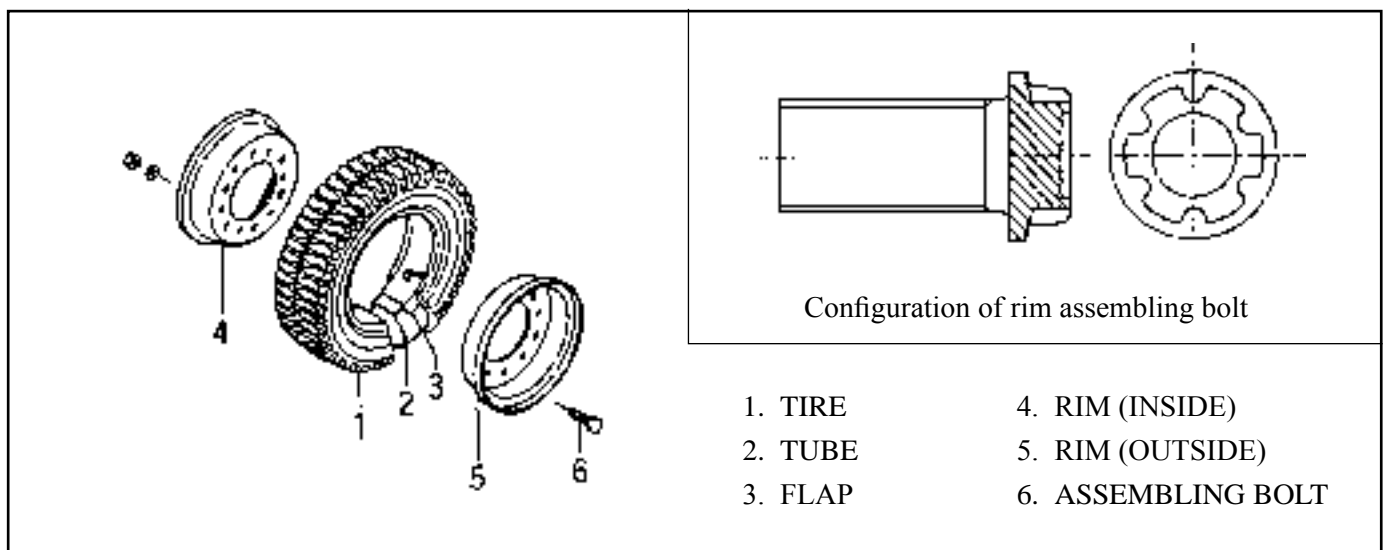

Fig. 3.7 Wheel Assembly (Trucks with capacities from 1.5, 2.0 to 2.5 tons)

3.1.1 REDUCTION GEAR AND DIFFERENTIAL

The reduction gear is located on the input shaft of the differential and reduces the power from the transmission, transmitting it to the differential.

The differential is fitted to the differential carrier through ball bearings with bearing caps and housed in the axle housing.

The differential cross case is a split type containing two side gears and four pinion gears, with thrust plates installed between the cross case and each gear according to their backlash.

The pinion gear is supported by the spider.

On the outer diameter of the cross case is a ring gear bolted. Each side gear is splined to the drive shaft so that the power sent from the transmission through the reduction gear is further reduced and differentiated by this device to drive the drive shaft.

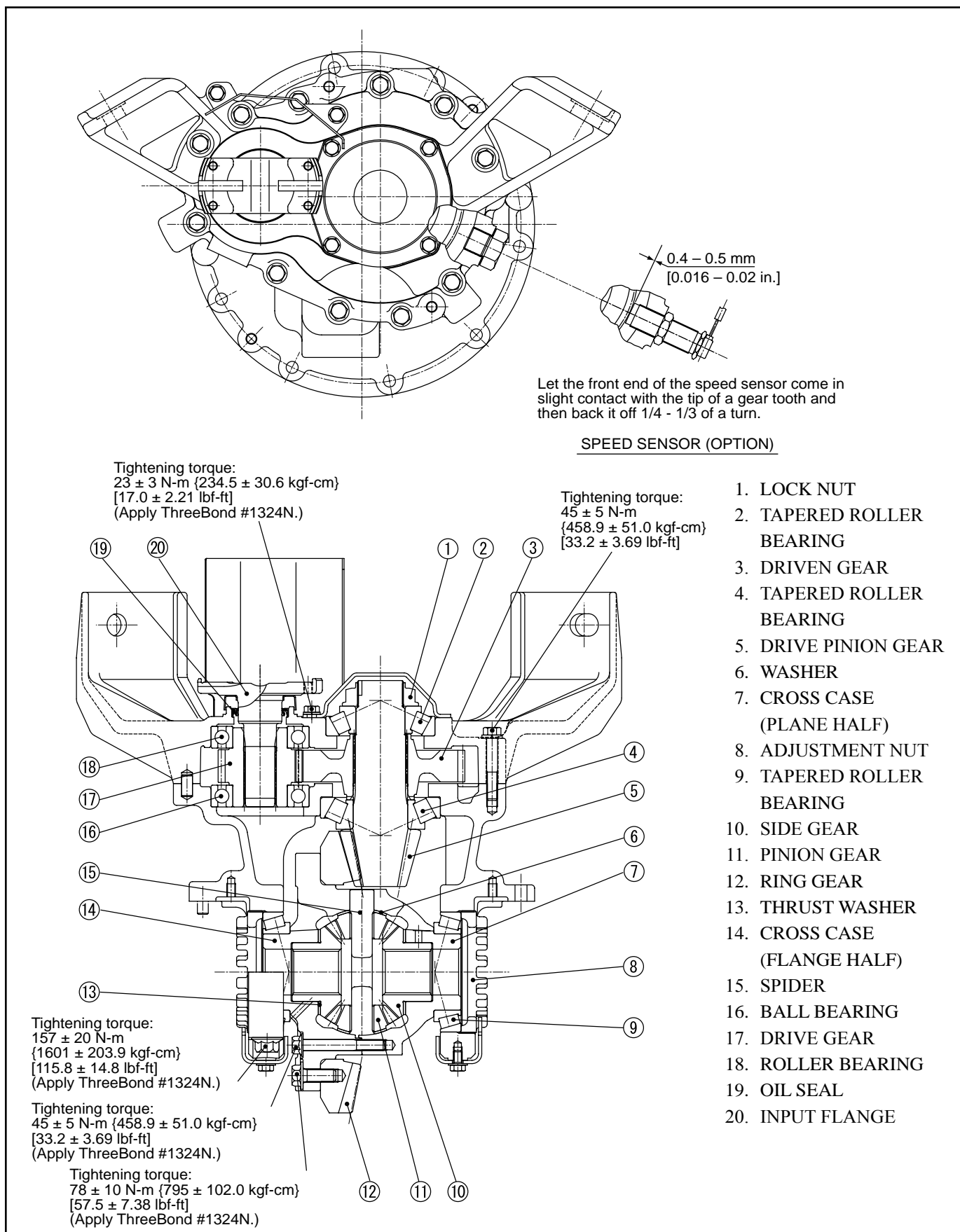
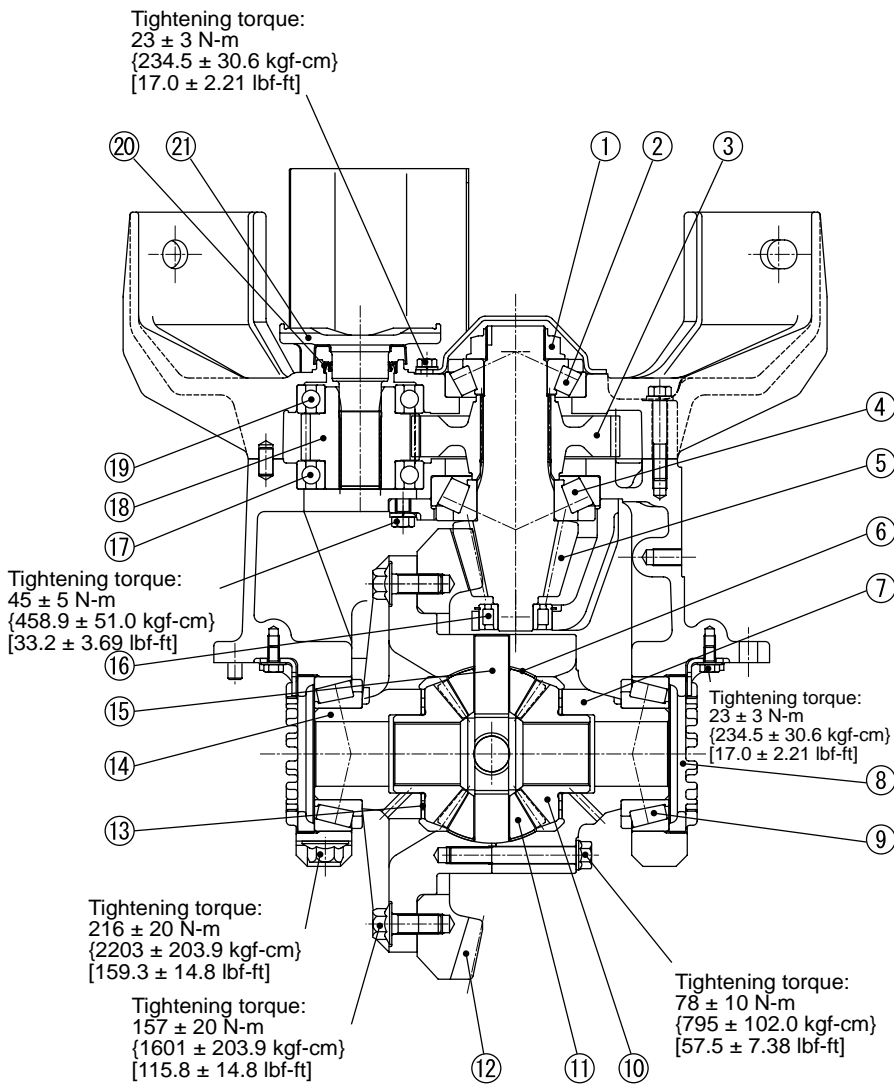
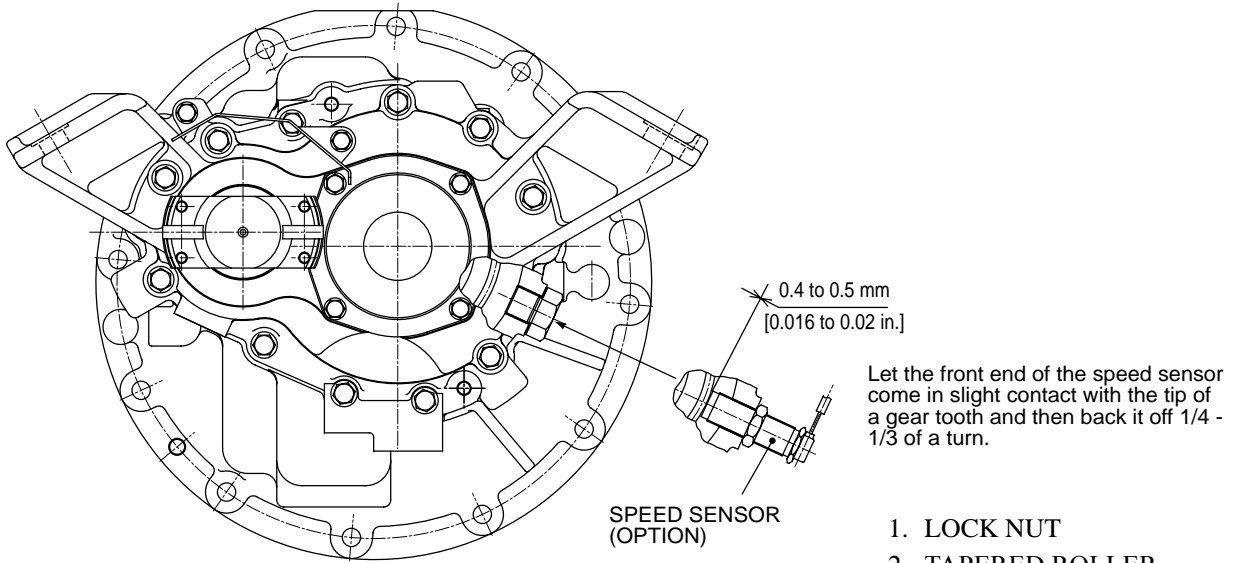

Fig. 3.8 Reduction Gear and Differential (Trucks with capacities from 1.5 to 1.75 tons)



1. LOCK NUT
2. TAPERED ROLLER BEARING
3. DRIVEN GEAR
4. TAPERED ROLLER BEARING
5. DRIVE PINION GEAR
6. WASHER
7. CROSS CASE (PLANE HALF)
8. ADJUSTMENT NUT
9. TAPERED ROLLER BEARING
10. SIDE GEAR
11. PINION GEAR
12. RING GEAR
13. THRUST WASHER
14. CROSS CASE (FLANGE HALF)
15. SPIDER
16. BEARING
17. BALL BEARING
18. DRIVE GEAR
19. ROLLER BEARING
20. OIL SEAL
21. INPUT FLANGE

Fig. 3.9 Reduction Gear and Differential (Trucks with capacities from 2.0 to 3.5 tons)

NOTE

A series of horizontal dashed lines intended for handwritten notes.

4. BRAKE SYSTEM

Truck Model	FHG15T3 FHG18T3 FHD15T3 FHD18T3	FG20T3 FHG20T3 FG25T3 FHG25T3	FD20T3 FHD20T3A FD25T3 FHD25T3A	FG30T3 FHG30T3 FD30T3 FHD30T3A FG35T3S FD35T3S
Item				
Type	Front two-wheel braking internal expansion, hydraulic type			
Pedal ratio	5.3		6.3	
Master cylinder bore	19.05 mm [0.75 in.] [3/4]			
Wheel brake	Duo-servo type			
Type	Duo-servo type			
Wheel cylinder bore	22.22 mm [0.87 in.]		28.58 mm [1.13 in.] [9/8]	
Brake drum inner dia.	254 mm [10 in.]		310 mm [12.21 in.]	314 mm [12.36 in.]
Lining size	279 x 48.5 x 5 mm [10.98 x 1.91 x 0.01 in.]		324 x 60 x 7 mm [12.76 x 2.36 x 0.28 in.]	348 x 76 x 7.67 mm [13.7 x 2.99 x 0.30 in.]
Surface brake	4 x 13530 mm ² [4 x 20.97 in. ²]		4 x 19440 mm ² [4 x 38.37 in. ²]	4 x 26400 mm ² [4 x 40.92 in. ²]
Parking brake	Front two-wheel braking internal expansion, mechanical type			
Type	Front two-wheel braking internal expansion, mechanical type			

4.1 GENERAL DESCRIPTION

The brake system is a front two-wheel braking internal expansion, hydraulic type consisting of a brake pedal, master cylinder and wheel brakes.

4.1.1 BRAKE PEDAL

The brake pedal unit has a structure as shown in Figure 4.1 and is installed through a bracket on the left side of the frame.

Pedal movement pushes the master cylinder piston through the push rod, converting brake pedal effort to oil pressure.

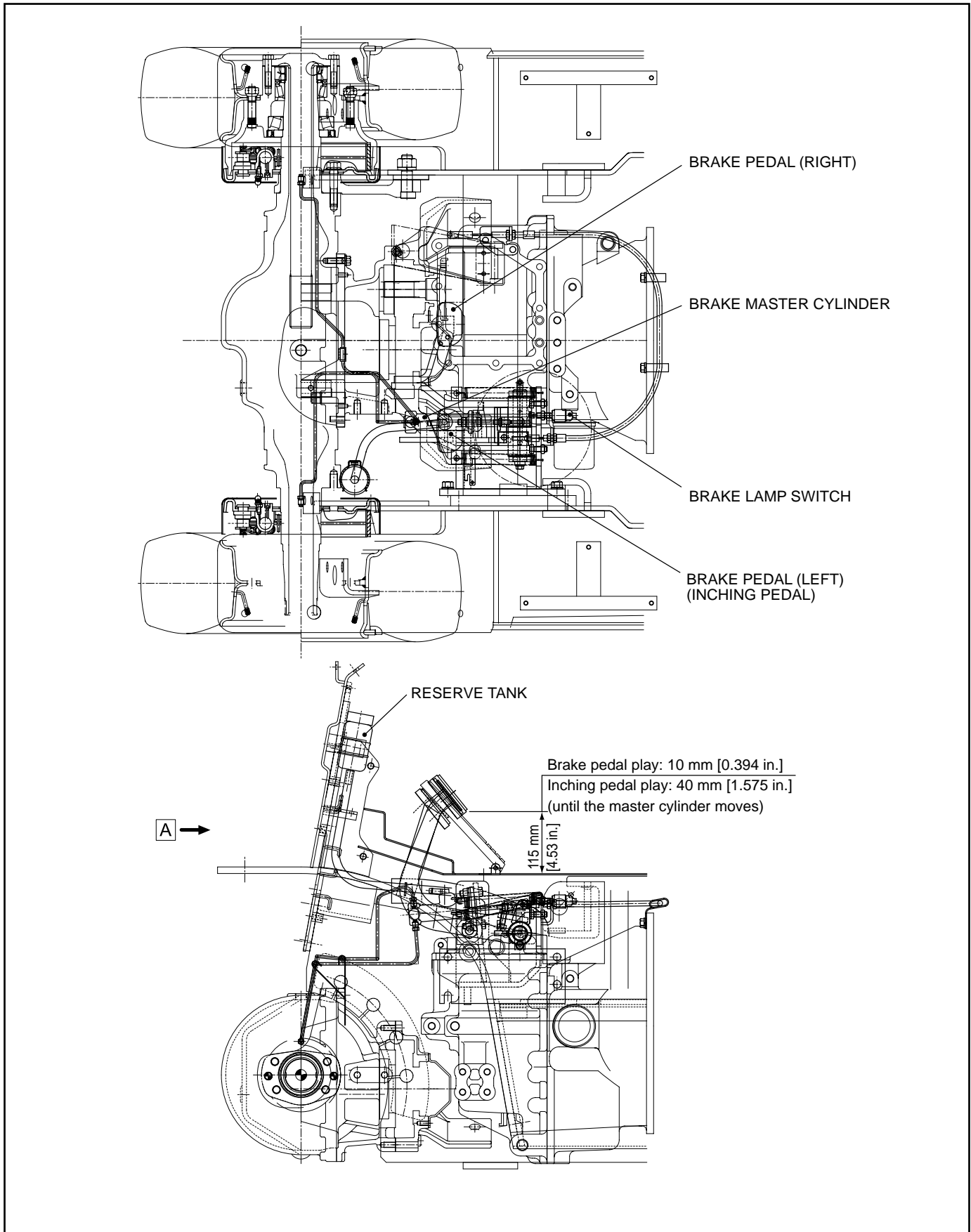
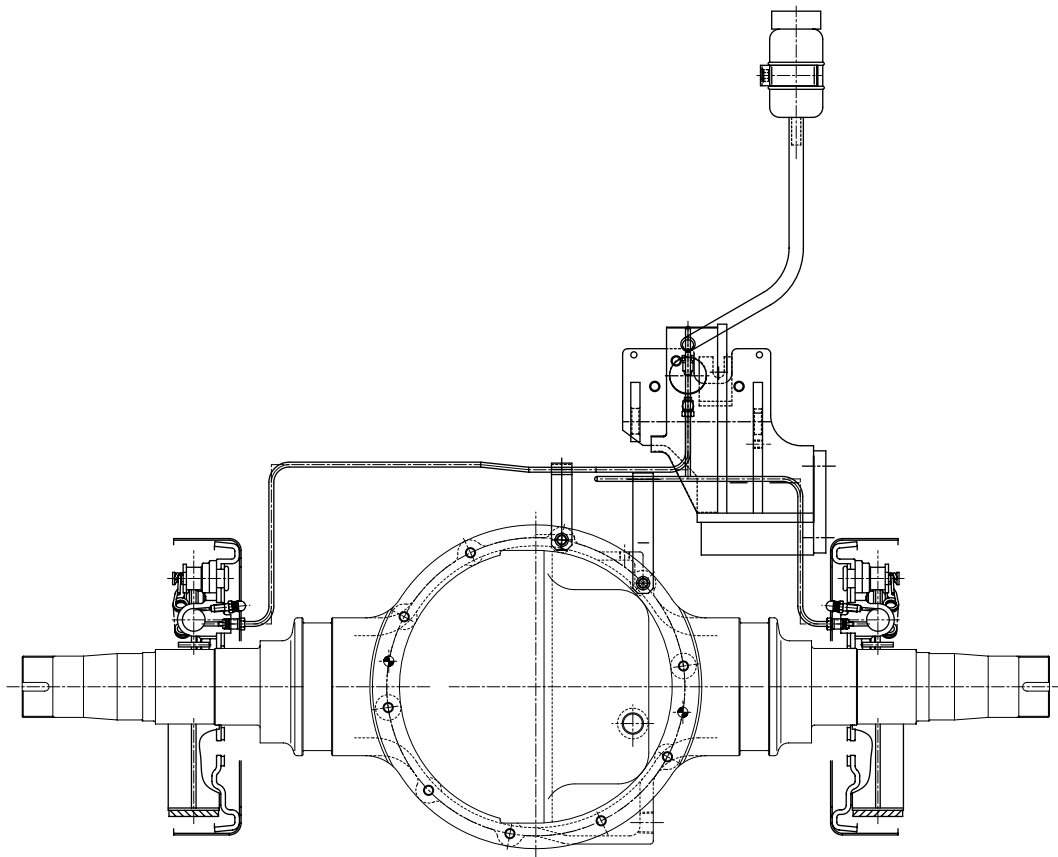
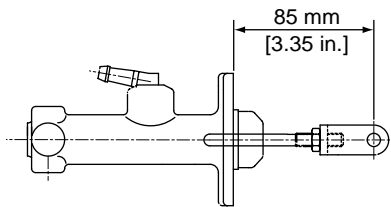

Fig. 4.1 Brake Pedal (Trucks with capacities from 1.5 to 1.75 tons) 1/2



View A



Detail of brake master cylinder

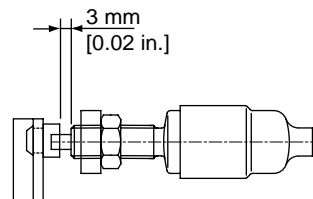

Detail of brake lamp switch

Fig. 4.2 Brake Pedal (Trucks with capacities from 1.5 to 1.75 tons) 2/2

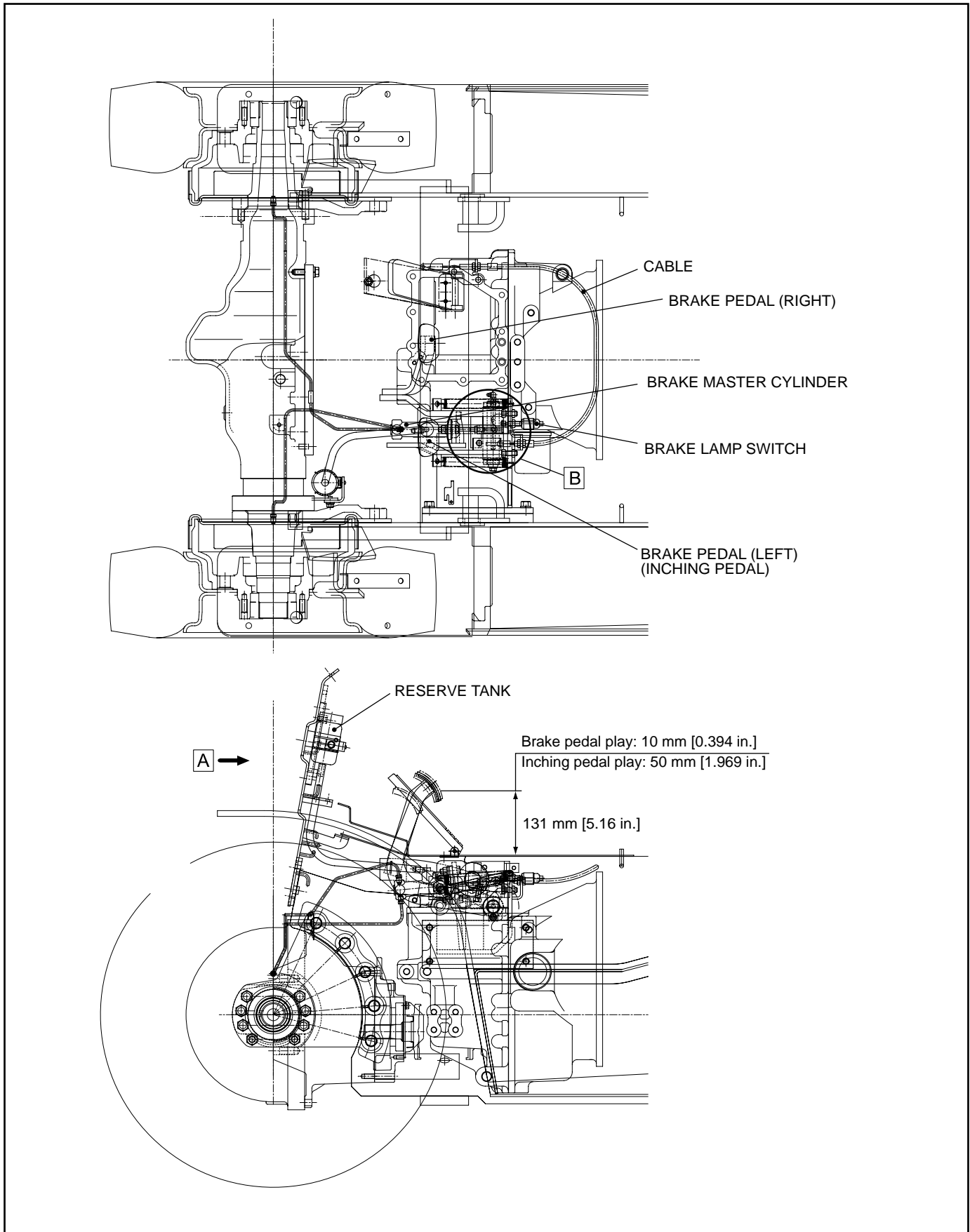

Fig. 4.3 Brake Pedal (Trucks with capacities from 2.0 to 3.5 tons) 1/2

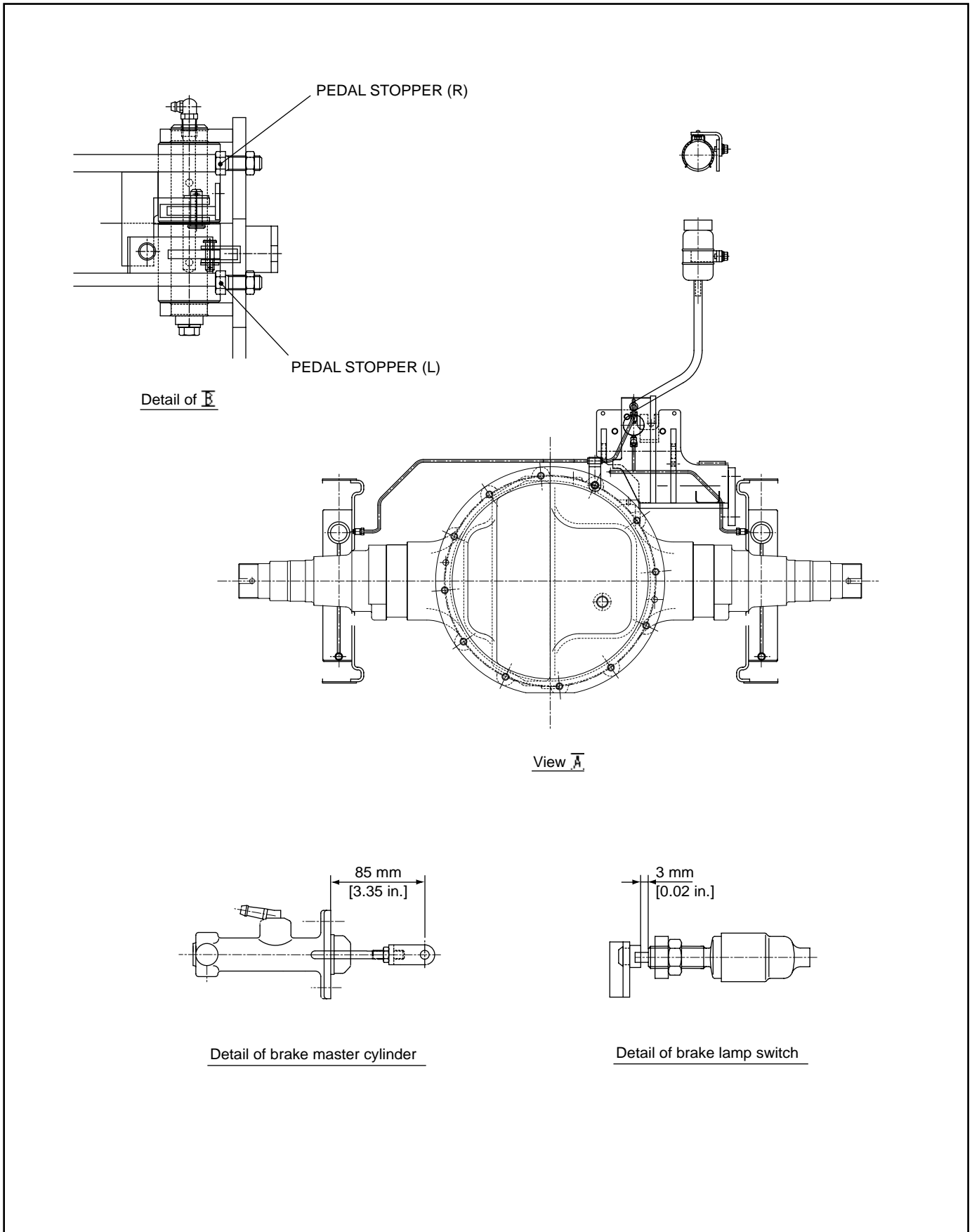

Fig. 4.4 Brake Pedal (Trucks with capacities from 2.0 to 3.5 tons) 2/2

4.1.2 MASTER CYLINDER

The master cylinder has a structure as shown in Figure 4.5 and is fitted to the bracket on the brake pedal. Built in the master cylinder are a spring and a piston which are kept in position by a snap ring.

The piston has a primary cup and a secondary cup and is slid in the cylinder by operating the brake pedal.

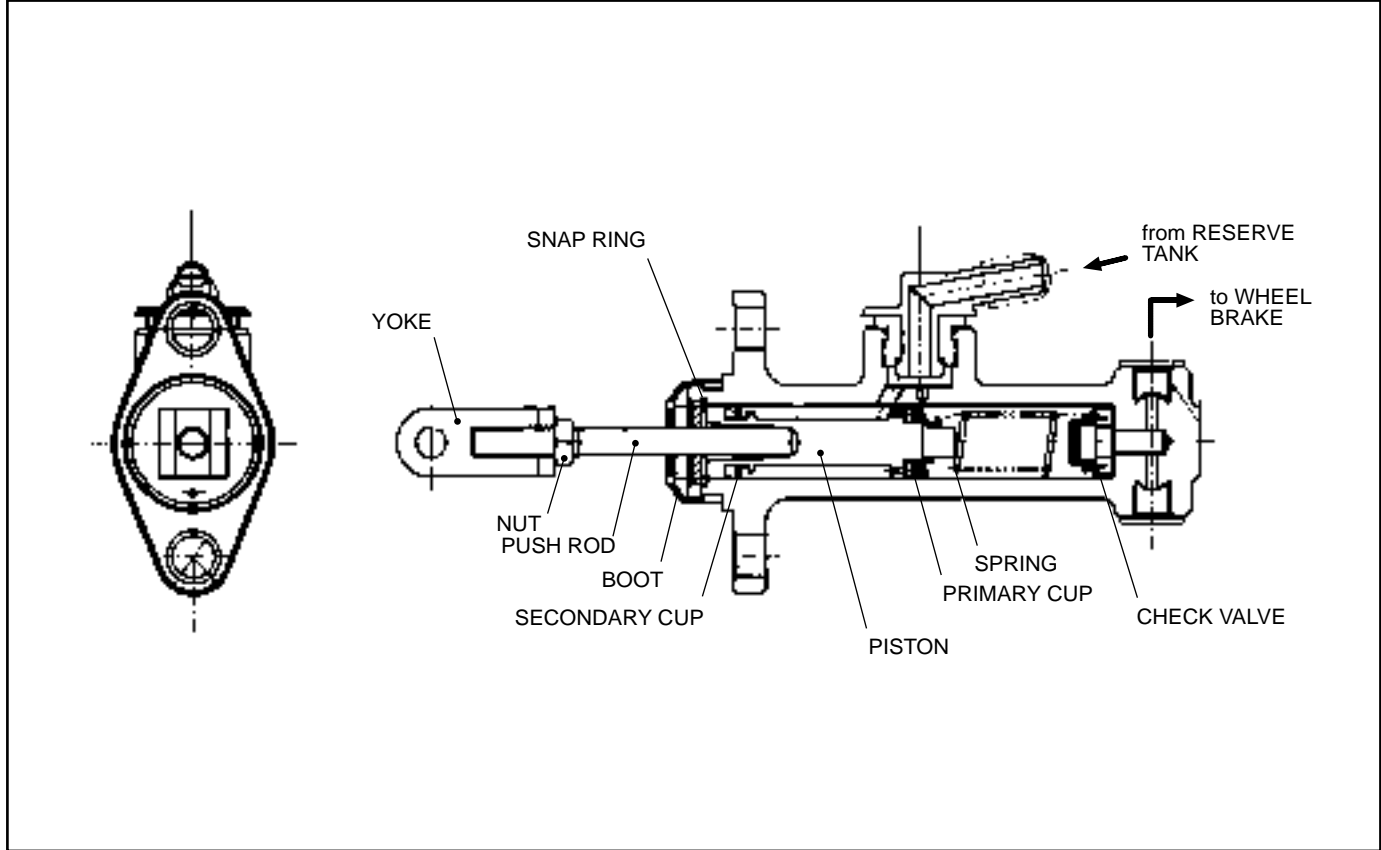

Fig. 4.5 Master Cylinder

The check valve works to leave some pressure inside the wheel cylinder and brake pipe in order to lock up the piston cup of the wheel cylinder. This prevents oil leakage and the occurrence of vapor lock.

4.1.3 WHEEL BRAKE

The wheel brake is a duo-servo type, and is mounted on each of both ends of the drive axle.

The wheel brake consists of two pairs of brake shoes, a wheel cylinder and an adjuster. The brake shoe, one end of it being connected to the anchor pin and the other end to the adjuster, is forced against the backing plate with a hold spring and pin.

In addition, the wheel brake is provided with a parking brake mechanism and an automatic clearance adjuster.

(1) Wheel brake operation

As the wheel cylinder presses the primary and secondary shoes with an equal force to the brake drum, they turn together with the brake drum until the secondary shoe top comes in contact with the anchor pin. When the secondary shoe top comes in contact with the anchor pin, the brake lining-to-brake drum friction force is produced and the primary shoe presses against the secondary shoe with force greater than offered by operation of the wheel cylinder, thus providing large braking force. (See Fig.4.6)

In reverse travel, the braking force works in the reverse direction. (See Fig.4.7)

(2) Parking brake

The parking brake unit is built in the wheel brake unit and consists of a lever and a strut. The lever is pinned to the primary shoe and movement of the lever is transmitted to the secondary shoe through the strut.

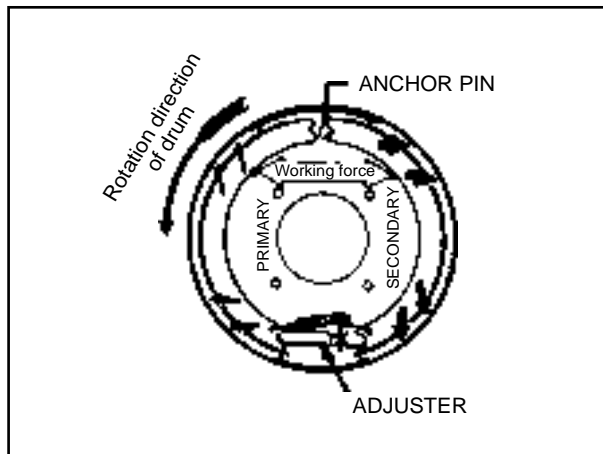

Fig. 4.6 Braking Operation in Forward Travel

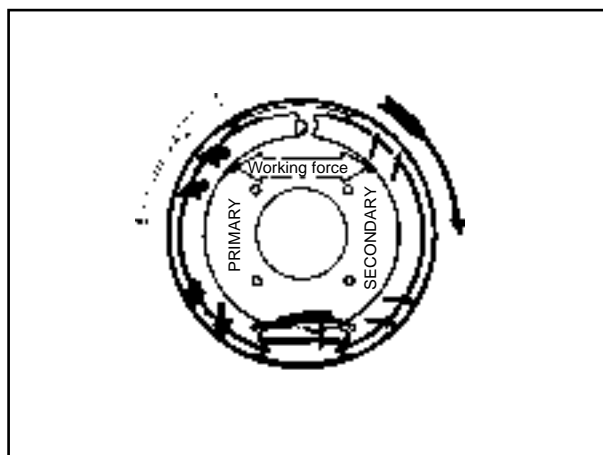

Fig. 4.7 Braking Operation in Reverse Travel

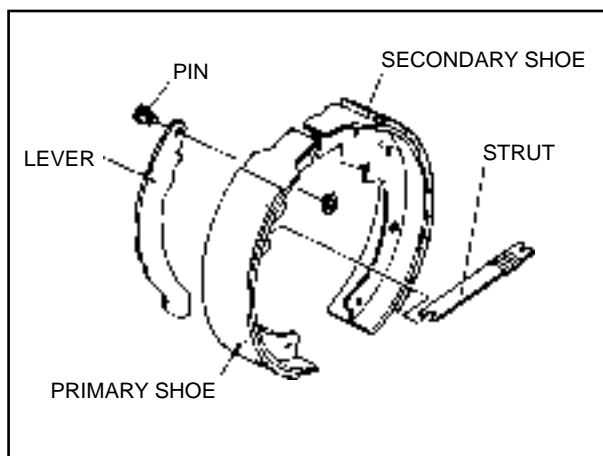

Fig. 4.8 Parking Brake Unit

(3) Automatic clearance adjuster

The automatic clearance adjuster keeps a proper lining-to-brake drum clearance automatically. The structure of the adjuster is shown in Figures 4.9 and 4.10.

This adjuster actuates only when the truck is braked in reverse travel. It varies in structured and operation with different truck models.

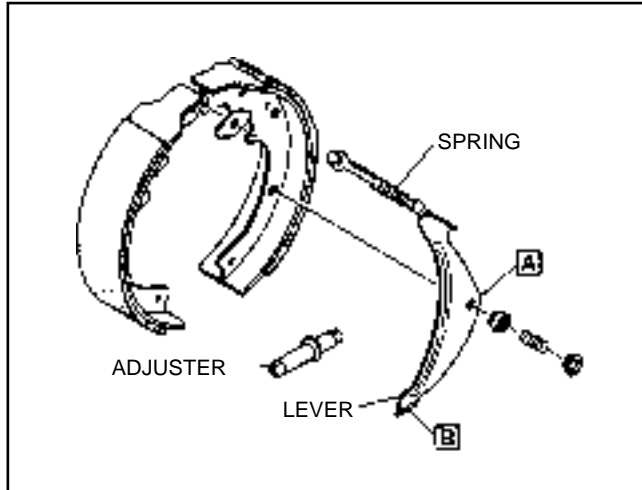

Fig. 4.9 Trucks with capacities from 2.0 to 2.5 tons

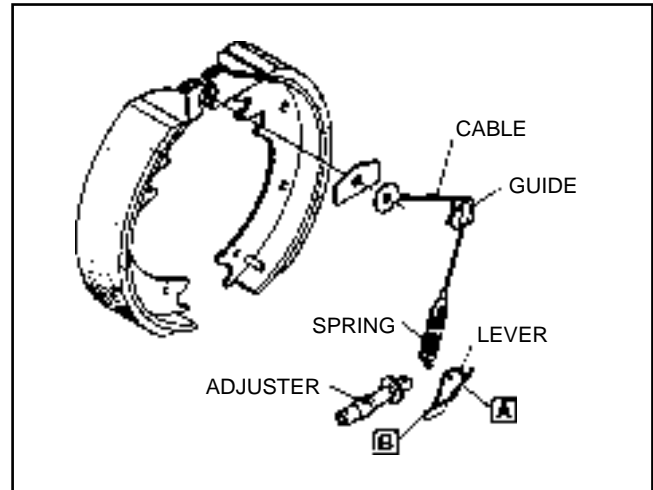

Fig. 4.10 Trucks with capacities from 1.5 to 1.75 and 3.0 to 3.5 tons

Automatic clearance adjuster operation

Trucks with capacities from 2.0 to 2.5 tons

When the brake is applied in reverse travel, the secondary shoe and the brake drum rotate together slightly. The lever turns to the right round the section A, causing the section B to rise.

When the brake is released, the lever is turned to the left round the section A, by spring force, causing the section B to move down.

As the lining-to-brake drum clearance becomes larger, the vertical movement of the section B grows. When the clearance becomes more than 0.4 mm [0.016 in.], the section B is engaged with the next tooth of the adjuster. When the section B engaged with the tooth moves down, the adjuster length expands to extend the shoe.

The clearance is thus adjusted within the range from 0.4 to 0.45 mm [0.016 to 0.018 in.] by the above operation.

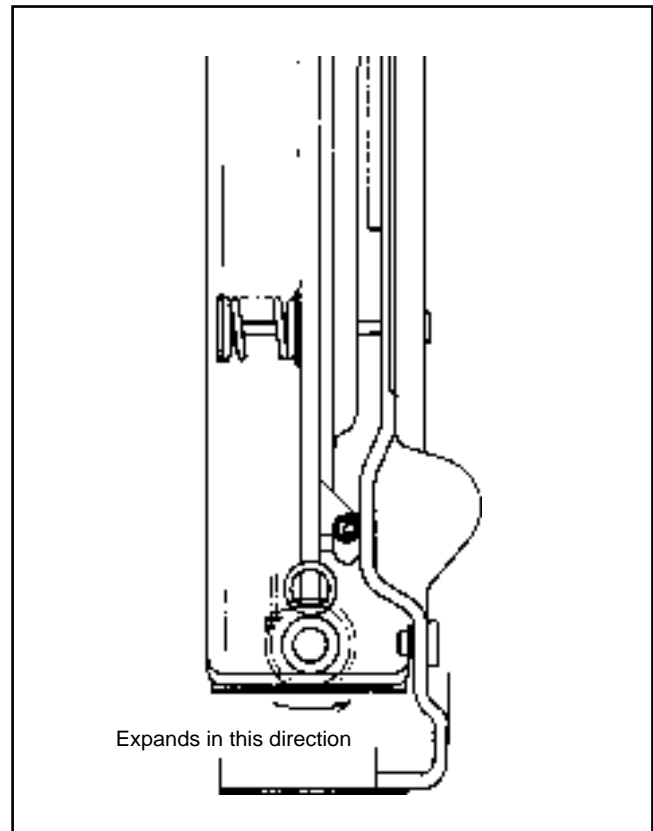

Fig. 4.11 Automatic Clearance Adjuster (Trucks with capacities from 2.0 to 2.5 tons)

Trucks with a capacity of 1.5 to 1.75 tons and 3.0 to 3.5 tons

When the brake is applied in reverse travel, the secondary shoe and the brake drum rotate together slightly. This turns the lever clockwise round the section A, shown in Figure 4.10, thus making the section E turn the adjuster.

If the braking force increases further, the force applied on the adjuster thread becomes so great that the adjuster cannot be turned any further.

When the brake is released, the brake shoe returns to the original position. This turns the lever counterclockwise round the section A, while the section E moves down.

At this time, if the position of an adjuster tooth is aligned with the section E of the lever, they engage with each other so that the clearance is adjusted to 0.25 to 0.4 mm [0.0098 to 0.016 in.].

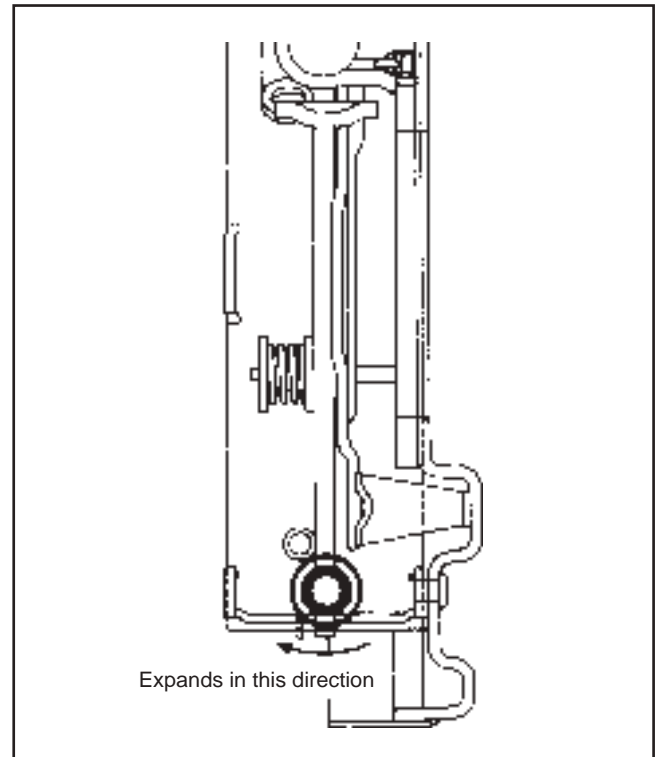
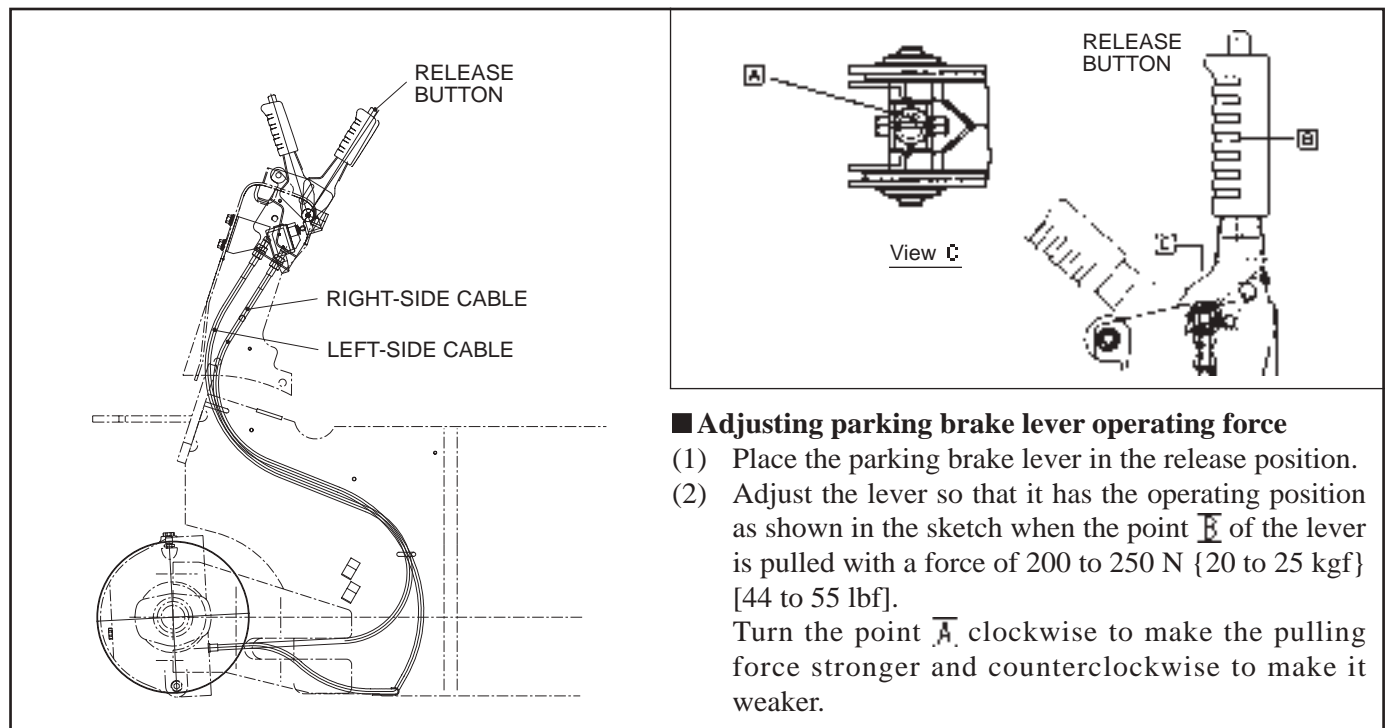

Fig. 4.12 Automatic Clearance Adjuster
(Trucks with capacities from 1.5 to 1.75 tons and 3.0 to 3.5 tons)

4.1.4 PARKING BRAKE LEVER

The parking brake lever is a toggle type and installed as shown in Figure 4.13. The lever has an adjuster on its head, with which you can adjust the braking force properly.



■ Adjusting parking brake lever operating force

- (1) Place the parking brake lever in the release position.
- (2) Adjust the lever so that it has the operating position as shown in the sketch when the point E of the lever is pulled with a force of 200 to 250 N {20 to 25 kgf} [44 to 55 lbf].
Turn the point A clockwise to make the pulling force stronger and counterclockwise to make it weaker.

Fig. 4.13 Parking Brake Lever

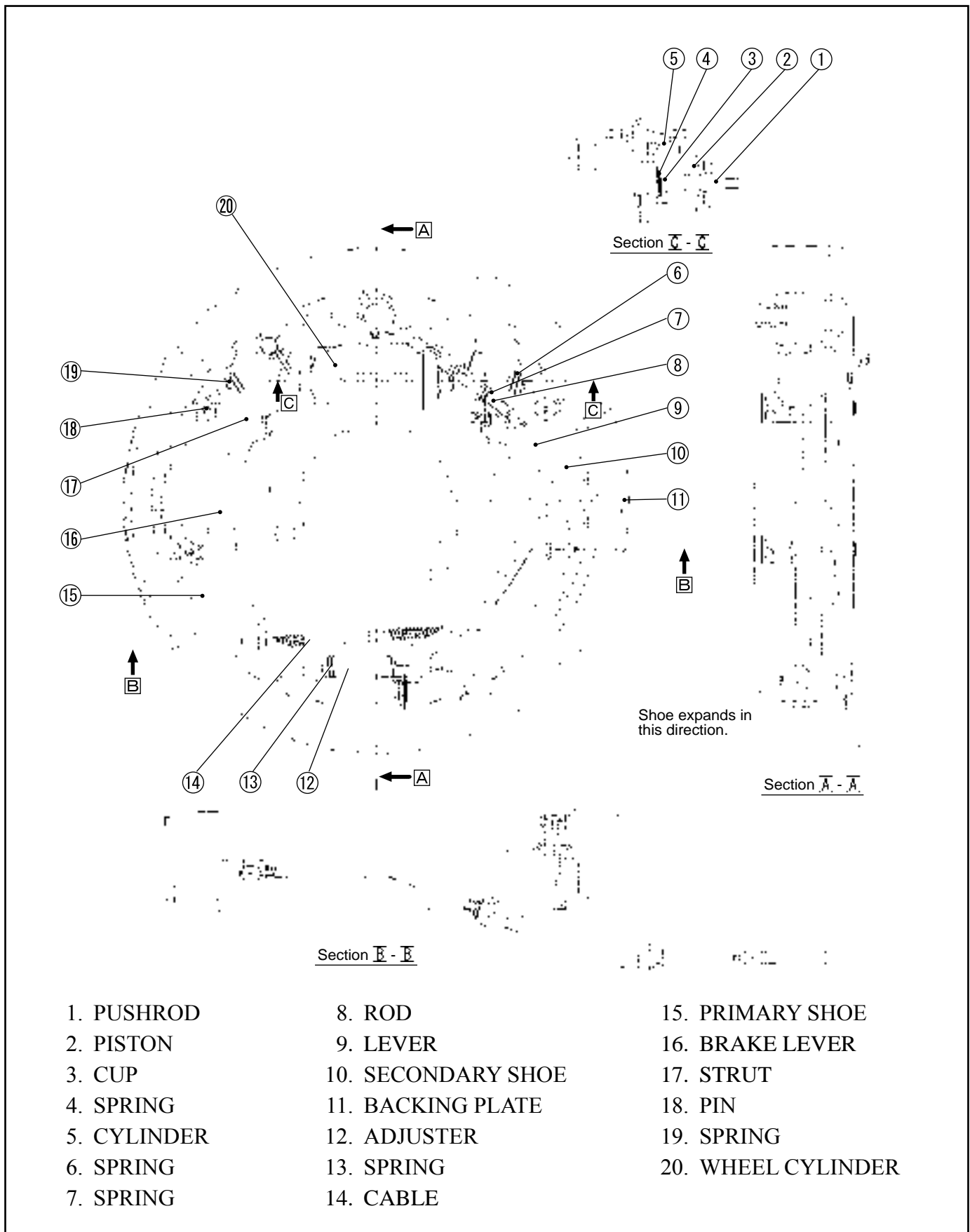
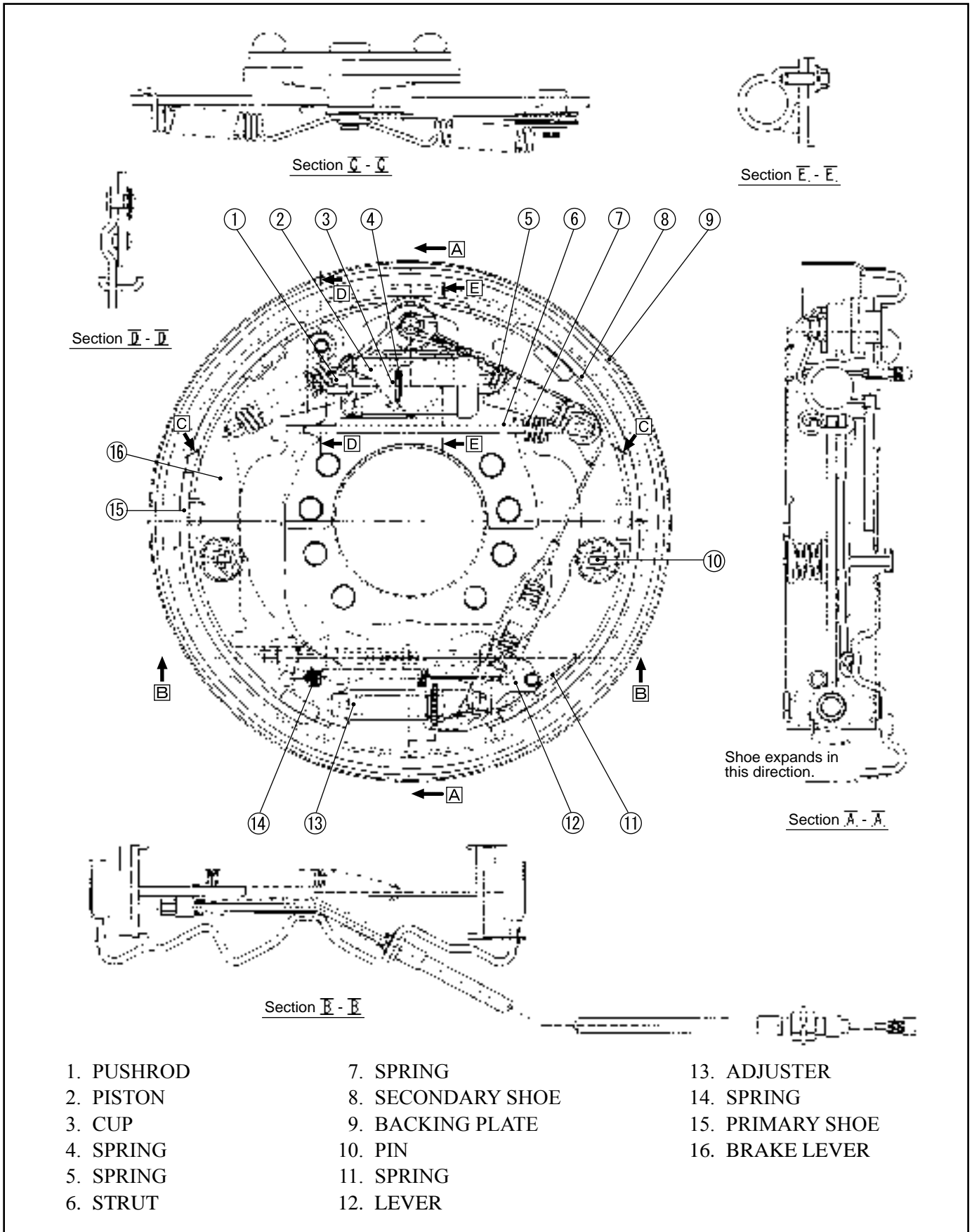

Fig. 4.14 Wheel Brake (Trucks with capacities from 2.0 to 2.5 tons)



- | | | |
|------------|-------------------|------------------|
| 1. PUSHROD | 7. SPRING | 13. ADJUSTER |
| 2. PISTON | 8. SECONDARY SHOE | 14. SPRING |
| 3. CUP | 9. BACKING PLATE | 15. PRIMARY SHOE |
| 4. SPRING | 10. PIN | 16. BRAKE LEVER |
| 5. SPRING | 11. SPRING | |
| 6. STRUT | 12. LEVER | |

Fig. 4.15 Wheel Brake (Trucks with capacities from 1.5 to 1.75 tons and 3.0 to 3.5 tons)

4.1.5 WHEEL BRAKE TROUBLESHOOTING

Problem	Probable cause	Remedy
Poor braking	1. Fluid leaks from brake system	Repair.
	2. Maladjustment of brake shoe clearance	Check and adjust adjuster.
	3. Overheated brake	Check for dragging.
	4. Poor contact between brake drum and lining	Adjust contact.
	5. Foreign matter adhered to lining	Replace.
	6. Foreign matter mixed in brake fluid	Change brake fluid.
	7. Maladjustment of brake pedal	Adjust.
Noisy brake	1. Hardened lining surface or foreign matter adhered thereto	Replace.
	2. Deformed backing plate	Replace.
	3. Deformed or improperly installed shoe	Repair or replace.
	4. Uneven wear of lining	Replace.
	5. Defective wheel bearing	Replace.
Uneven braking	1. Contaminated lining	Replace.
	2. Maladjustment of brake shoe clearance	Check and adjust adjuster.
	3. Malfunctioning wheel cylinder	Repair or replace.
	4. Defective shoe return spring	Replace.
	5. Run out of drum	Repair or replace.
	6. Improper inflation pressure of tire	Adjust.
Soft or spongy brake	1. Fluid leaks from brake system	Repair.
	2. Maladjustment of break shoe clearance	Check and adjust adjuster.
	3. Air mixed in brake system	Bleed air out of system.
	4. Maladjustment of brake pedal	Adjust.

5. STEERING SYSTEM

Truck Model			FG20 _{T3}	FD20 _{T3}	FG30 _{T3}		
	FHG15 _{T3} FHD15 _{T3}	FHG18 _{T3} FHD18 _{T3}	FHG20 _{T3} FG25 _{T3} FHG25 _{T3}	FHD20 _{T3A} FD25 _{T3} FHD25 _{T3A}	FHG30 _{T3} FD30 _{T3} FHD30 _{T3A}	FG35 _{T3S} FD35 _{T3S}	
Steering axle							
Type	Center-pin supported, Elliot type with box-shaped cross section of weld construction						
King pin spacing	780 mm [30.71 in.]				810 mm [31.89 in.]		
King pin angle			0°				
Toe-in			0 mm				
Camber			1°				
Caster			0°				
Steering angle							
Inner wheel	78°				78.9°		
Outer wheel	54°				54.1°		57°
Orbitrol							
Type	Open-centered, non-load reaction type with steering wheel knob deviation control						
Discharge	80 cm ³ [4.88 in. ³]/rev				96 cm ³ [5.86 in. ³]/rev		
Power cylinder							
Type	Double-acting piston type						
Cylinder bore	71 mm [2.8 in.]				80 mm [3.15 in.]		
Piston rod diameter	40 mm [1.57 in.]				50 mm [1.97 in.]		
Stroke	132 mm [5.2 in.]				171 mm [6.73 in.]		177 mm [6.97 in.]
Flow divider valve							
Flow rate	20 liters [5.28 U.S. gal]/min				60 liters [15.85 U.S. gal]/min		
Pressure setting	6.86 MPa {70 kgf/cm ² } [995 psi]				8.8 MPa {90 kgf/cm ² } [1276 psi]		

5.1 GENERAL DESCRIPTION

The steering system consists primarily of a steering wheel, an orbitrol, and a power cylinder. When the steering wheel is turned, the rotation is transmitted to the orbitrol; the oil passages in the orbitrol are changed over to direct the hydraulic pressure from the flow divider valve to the power cylinder, which extends or contracts depending on the hydraulic pressure, thereby steering the truck.

5.1.1 STEERING AXLE

The steering axle is of steel-welded construction with a box shaped cross section, incorporating a power cylinder inside it. See Figures 5.1 and 5.2. The power cylinder is housed in the axle to protect it from being damaged by obstacles on the road surface. The axle is installed onto the truck frame through a center pin with bushing and cap, and it cradles around this center pin.

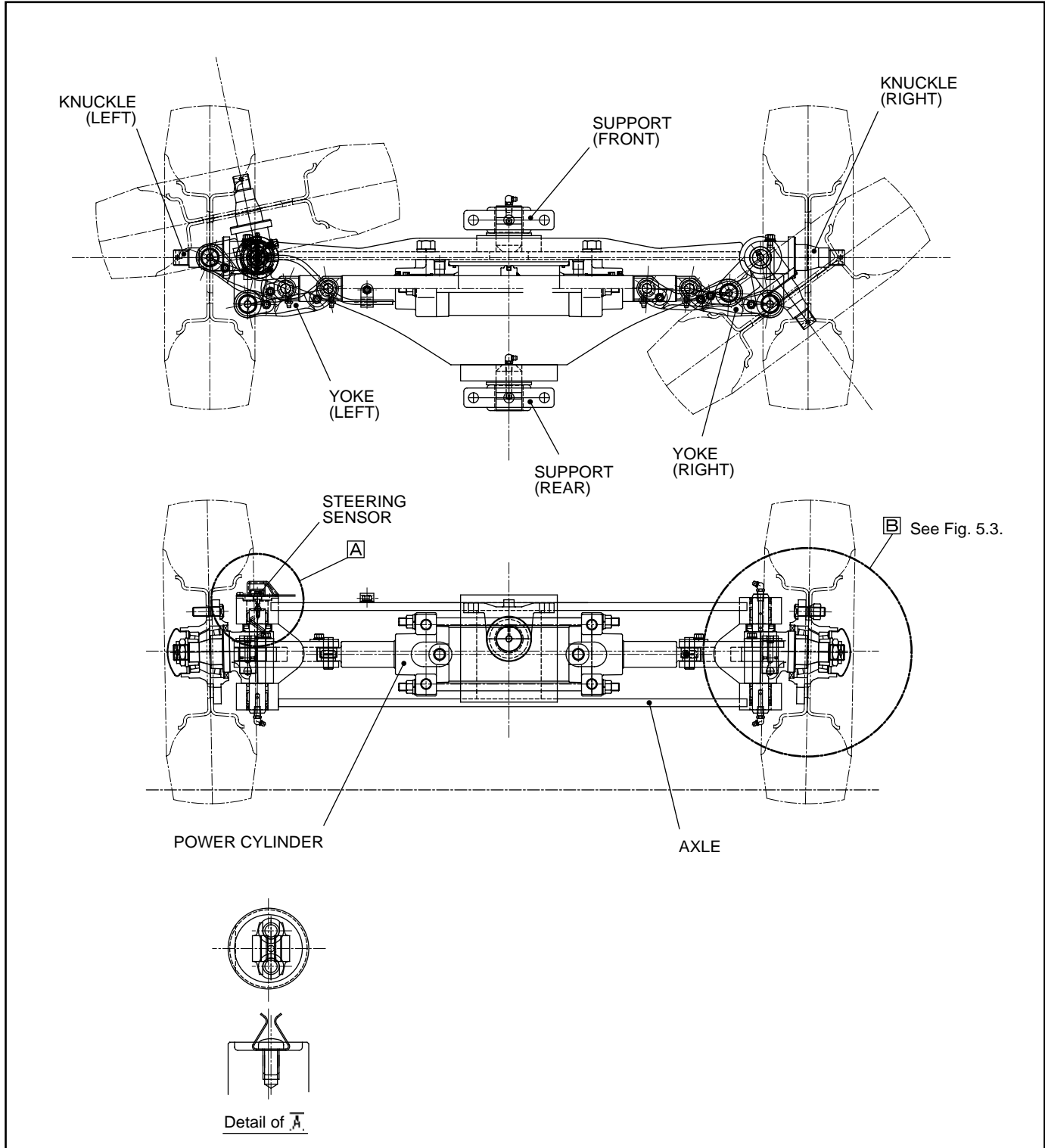

Fig. 5.1 Steering Axle (Trucks with capacities from 1.5 to 1.75 tons)

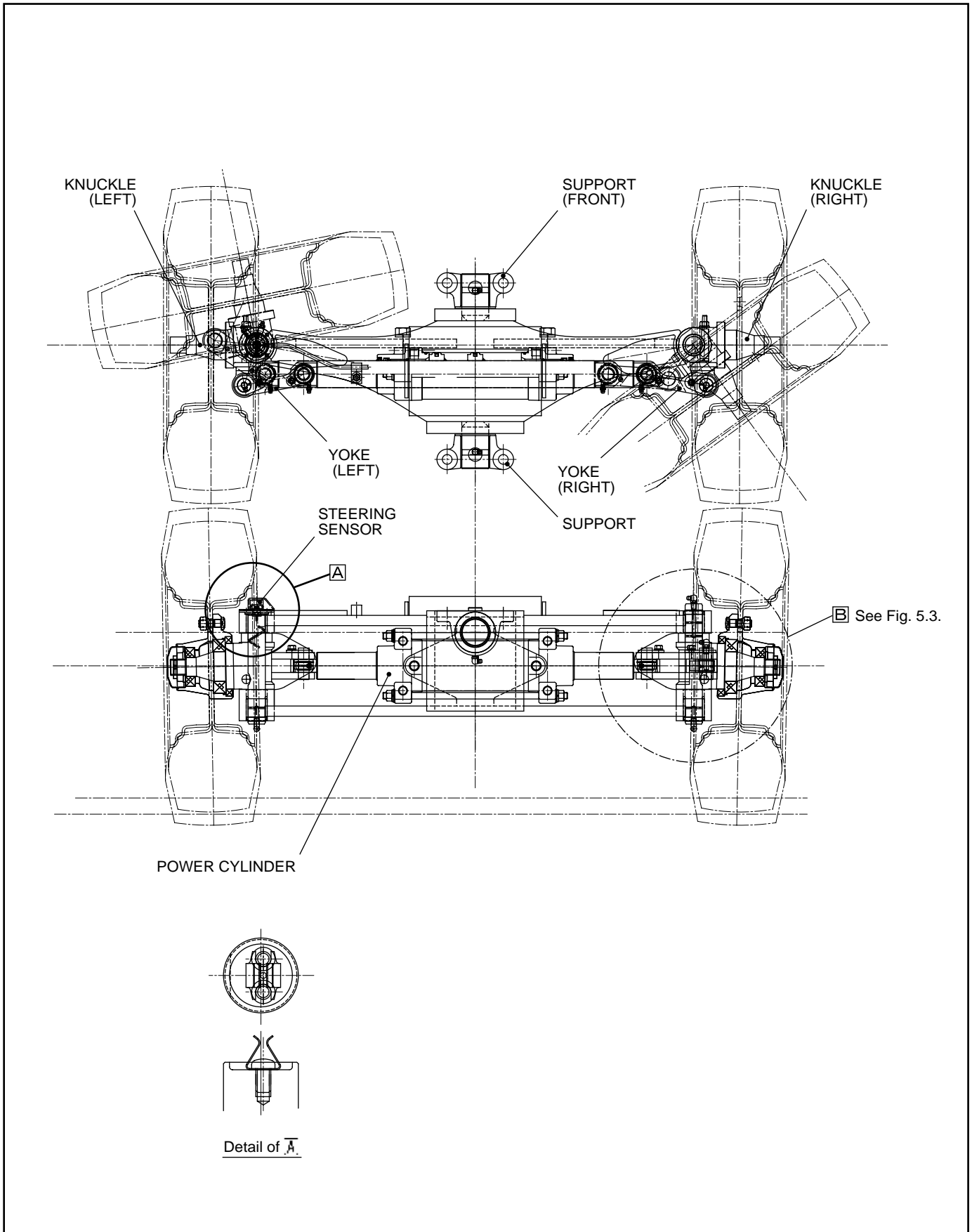

Fig. 5.2 Steering Axle (Trucks with capacities from 2.0 to 3.5 tons)

(1) Knuckle and king pin

The knuckle is supported with a king pin which in turn is secured at the knuckle side with a lock pin. The top and bottom of the king pin are fitted to the axle boss with needle bearings.

Between the axle boss and the knuckle is a thrust bearing to let the knuckle smoothly rotate around the king pin, sustaining load.

The needle bearings and thrust bearing are lubricated by grease supplied through the grease fittings at top and bottom of the king pin.

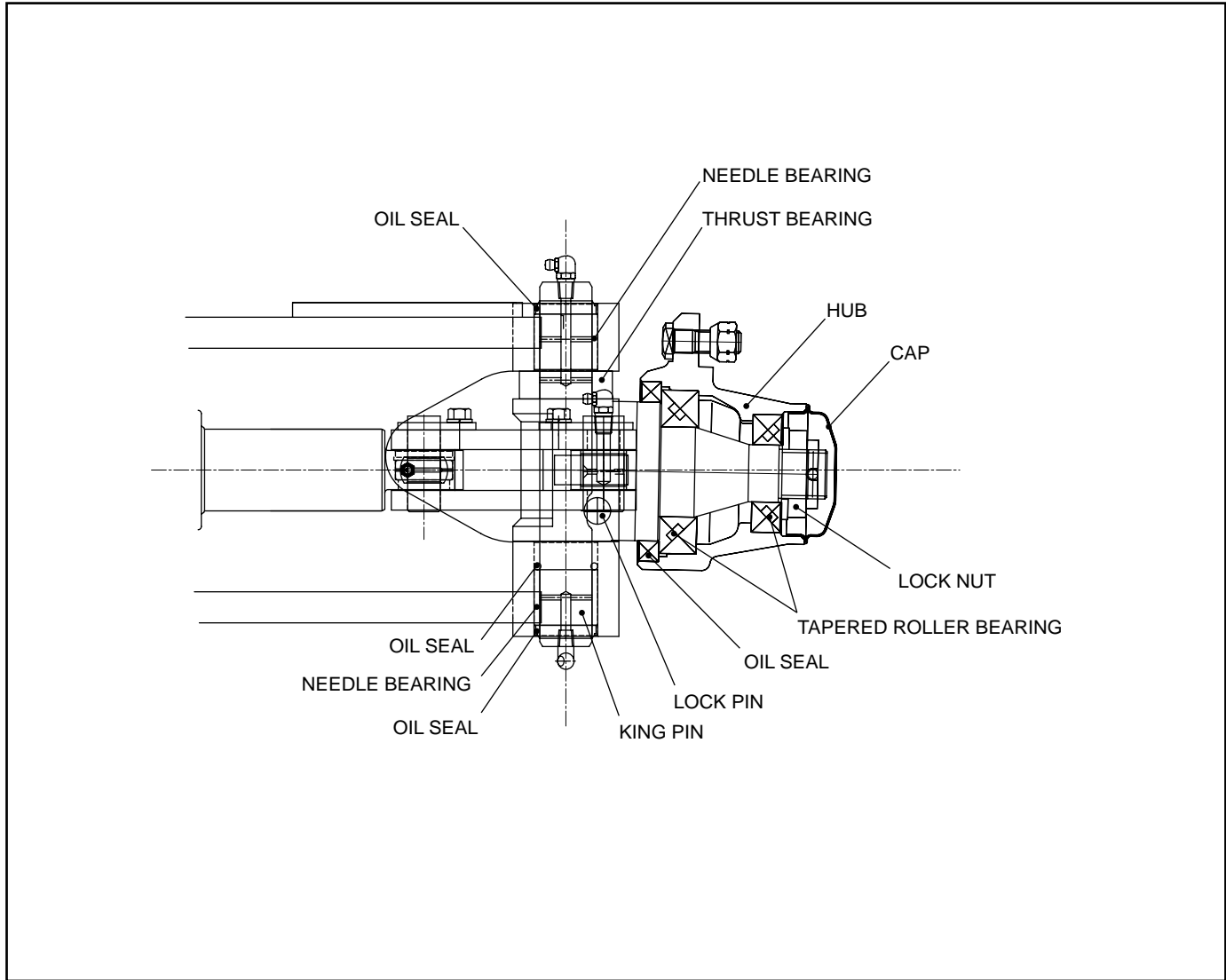

Fig. 5.3 Knuckle

(2) Wheel hub

The wheel hub is mounted on the knuckle spindle with two tapered roller bearings and its preload is adjusted with a nut.

5.1.2 STEERING WHEEL ASSEMBLY

The steering wheel assembly is arranged as shown in Figure 5.4. The orbitrol is located at the bottom of the assembly. At the center of the steering wheel is the horn button.

The steering shaft is connected to the drive shaft of the orbitrol. The steering wheel can be moved to a certain extent back and forth to suit the driver's physique.

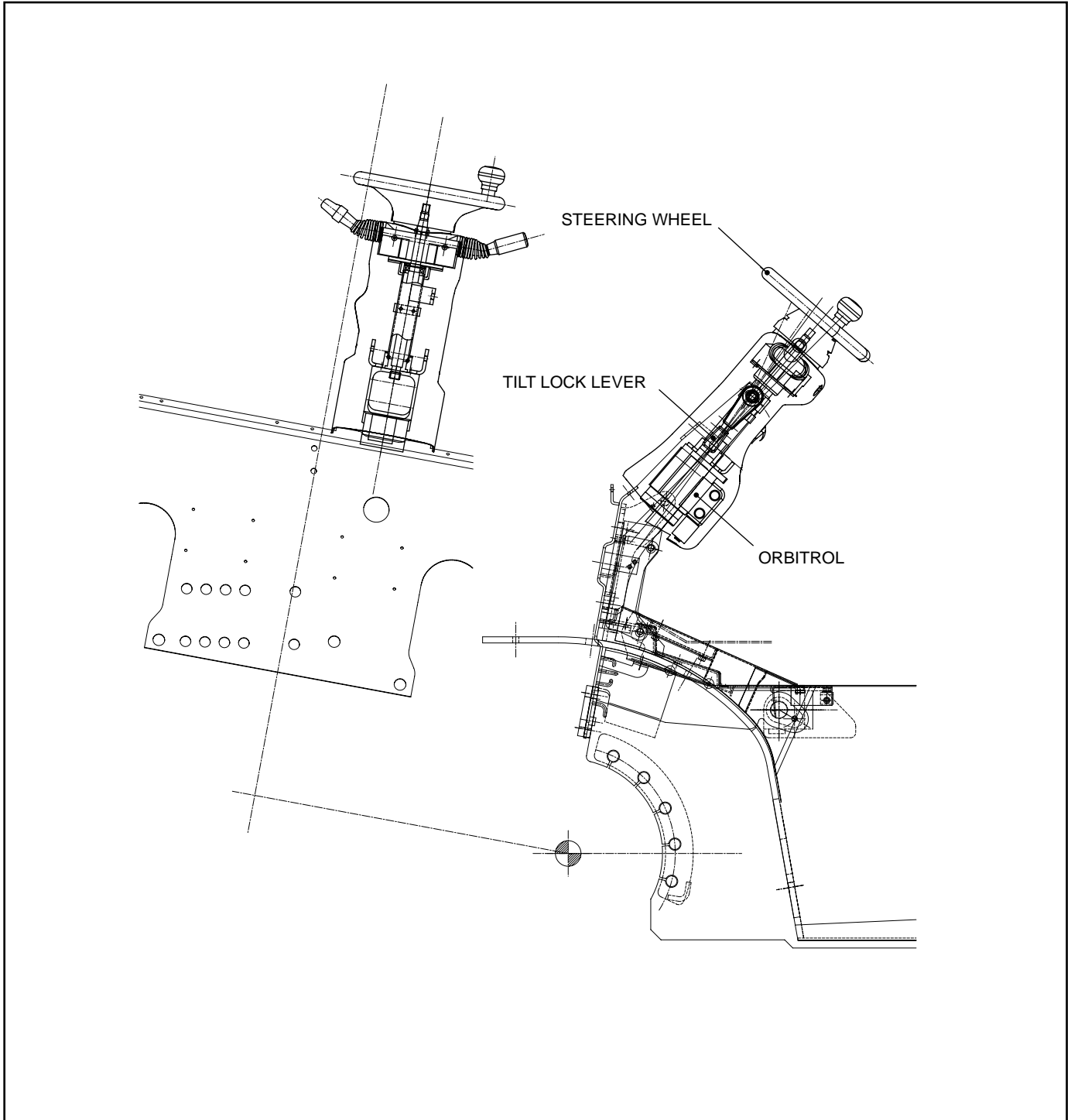

Fig. 5.4 Steering Wheel Assembly

5.1.3 ORBITROL

The orbitrol sends pressure oil from the pump selectively to the steering cylinder. It consists primarily of a control valve and a metering device.

The control valve used in this orbitrol is not an ordinary spool type whose spool moves in the axial direction, but a rotary type consisting of a sleeve and a spool, which rotates to switch over the oil passages. The housing has four ports which lead to the pump, tank, right and left chambers of the steering cylinder, respectively. Between the P port and T port is a check valve provided.

The metering device consists of an internally-toothed stator and an externally-toothed rotor. It works as an oil motor under normal operating conditions and can be used as a hand pump if the truck becomes disable for any reason. The rotor is mechanically linked to the sleeve with the drive shaft so that feedback operation is possible.

The sleeve is interlocked with the motor's rotor through the cross pin and drive shaft while the spool is splined to the steering shaft.

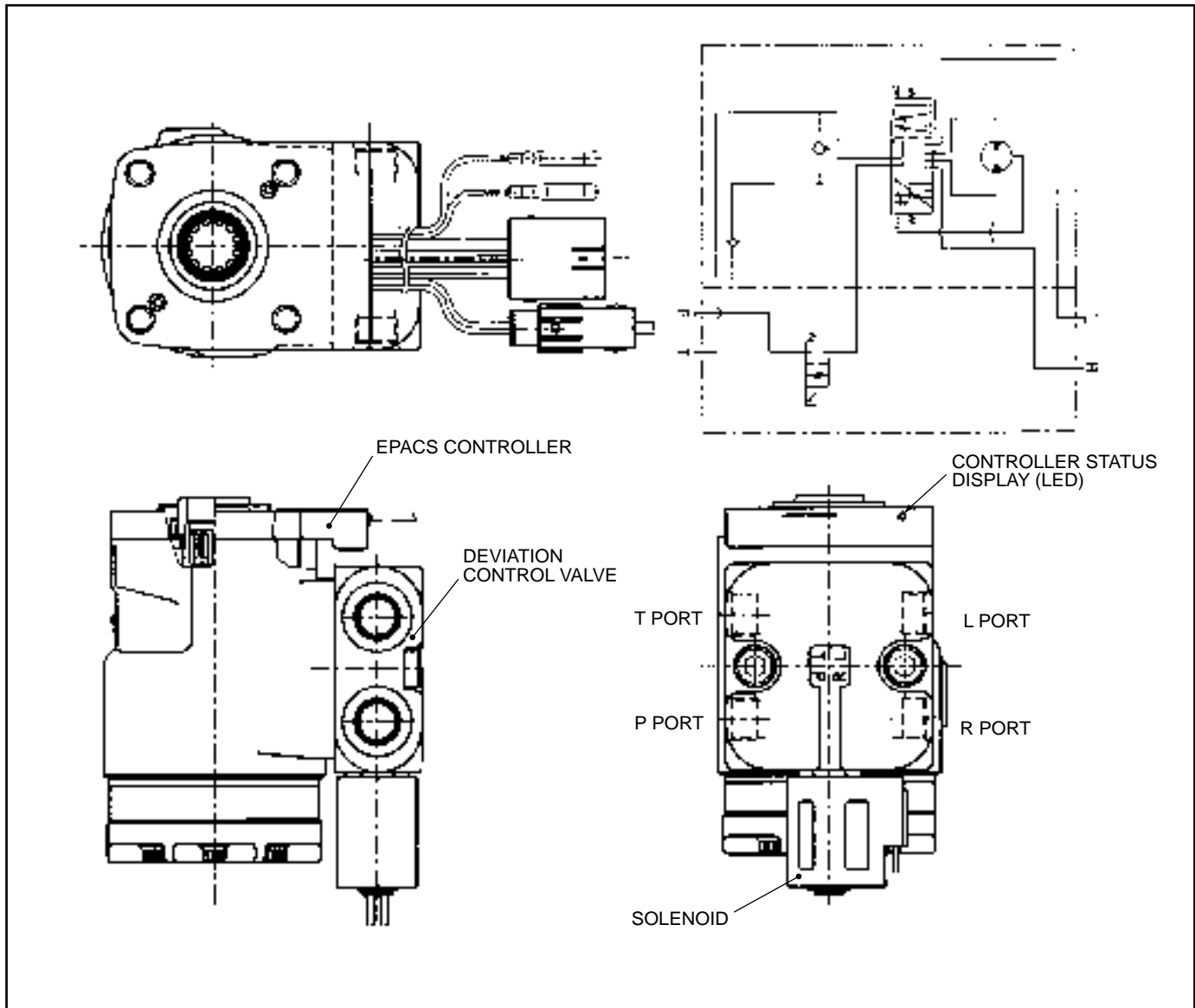

Fig. 5.5 Orbitrol

(1) Operation of orbitrol

(a) In "Neutral"

While the steering wheel is in straight position, the oil from the pump flows through oil passage 1 to oil groove 2. The sleeve has 24 oil holes 3 which are now in line with the holes 4 in the spool so that the oil that flowed into groove 2 passes through oil holes 3 and 4 to space 5 between the spool and drive shaft. Then the oil flows through spool groove 6 and sleeve groove 7 back to the oil tank.

Since cylinder ports 8 and 9 are respectively open to oil holes 10 and 11 in the sleeve but not to groove 12 nor 13 in the spool, the oil in the cylinder does not go anywhere.

Oil passage 14 that leads to the hydraulic motor is open to oil hole 15 in the sleeve which is used as the inlet and outlet for the hydraulic motor, but not to grooves 16 nor 17 in the spool and thus the oil remain unmoved.

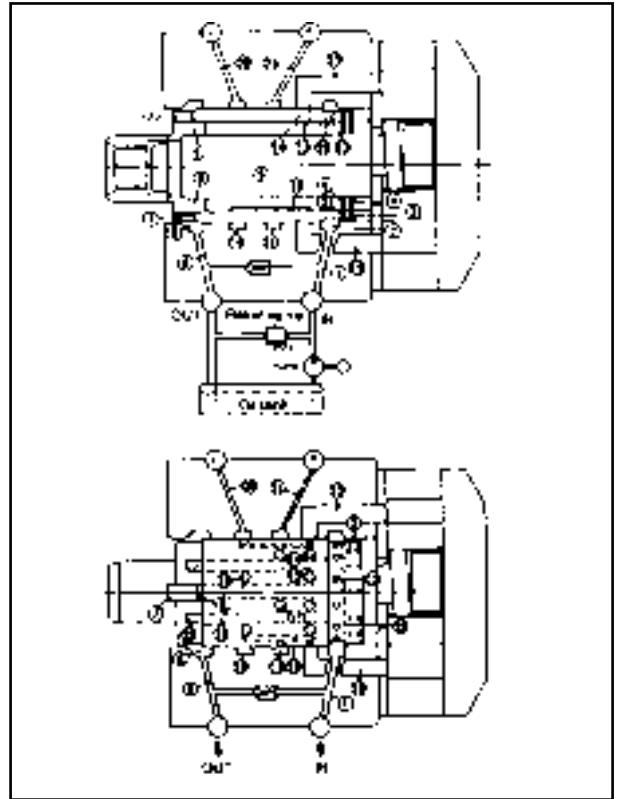

Fig. 5.6

(b) When steering wheel is turned counterclockwise

As the steering wheel is turned counterclockwise, the grooves in the spool shift to the left in relation with the holes and grooves in the sleeve so that holes 4 in the spool get out of line with holes 3 in the sleeve. The oil that has flowed into groove 2 thus far begins to flow into hole 12 in the sleeve, passing through grooves 13 and 14 in the spool, hole 15 in the sleeve, and oil passage 16 in the housing, to the hydraulic motor.

The hydraulic motor thus rotates in the counterclockwise direction and the oil discharged from the hydraulic motor flows through oil hole 17 in the sleeve, groove 18 in the spool, and oil hole 19 in the sleeve to the cylinder port L in the housing and thus actuates the steering cylinder.

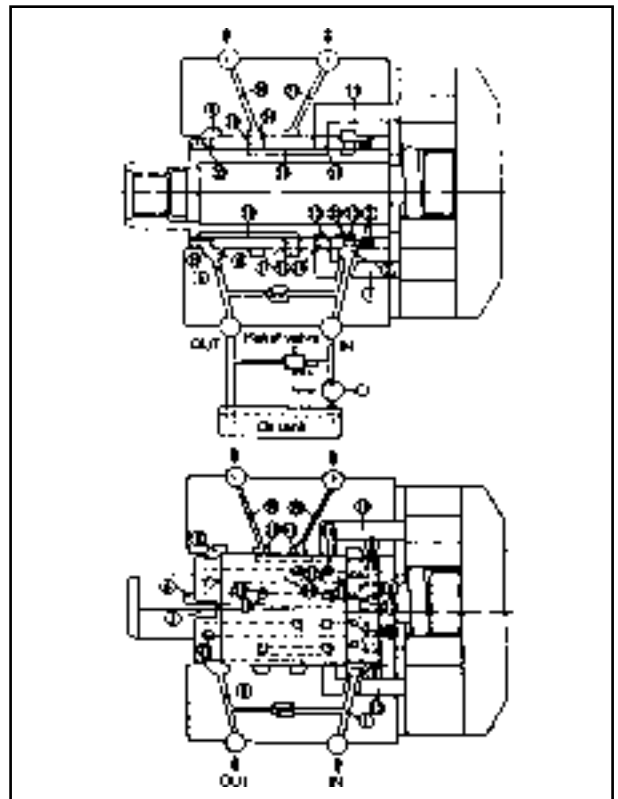

Fig. 5.7

The returning oil from the power cylinder flows, passing through the cylinder port R, groove 11 in the valve housing, oil hole 17 in the sleeve, groove 18 in the spool, oil hole 22 in the sleeve, and groove 8 in the valve housing, back to the oil tank.

(c) When steering wheel is turned clockwise

As the steering wheel is turned clockwise, the grooves in the spool shift to the right in relation to the oil holes and grooves in the sleeve so that oil holes 10 in the spool get out of line with holes 24 in the sleeve. The oil that has flowed into groove 22 thus far begins to flow into oil hole 12 in the sleeve and then flows through grooves 23 and 13 in the spool, oil hole 11 in the sleeve, and oil passage 15 in the valve housing to the hydraulic motor. The hydraulic motor thus rotates in the clockwise direction and the oil discharged from the hydraulic motor flows through oil hole 11 in the sleeve, groove 13 in the spool, and oil hole 17 in the sleeve to the cylinder port R in the housing and thus actuates the power cylinder.

The returning oil from the power cylinder flows, passing through the cylinder port L, groove 10 in the housing, oil hole 13 in the sleeve, groove 18 in the spool, oil hole 22 in the sleeve and groove 9 in the housing back to the oil tank.

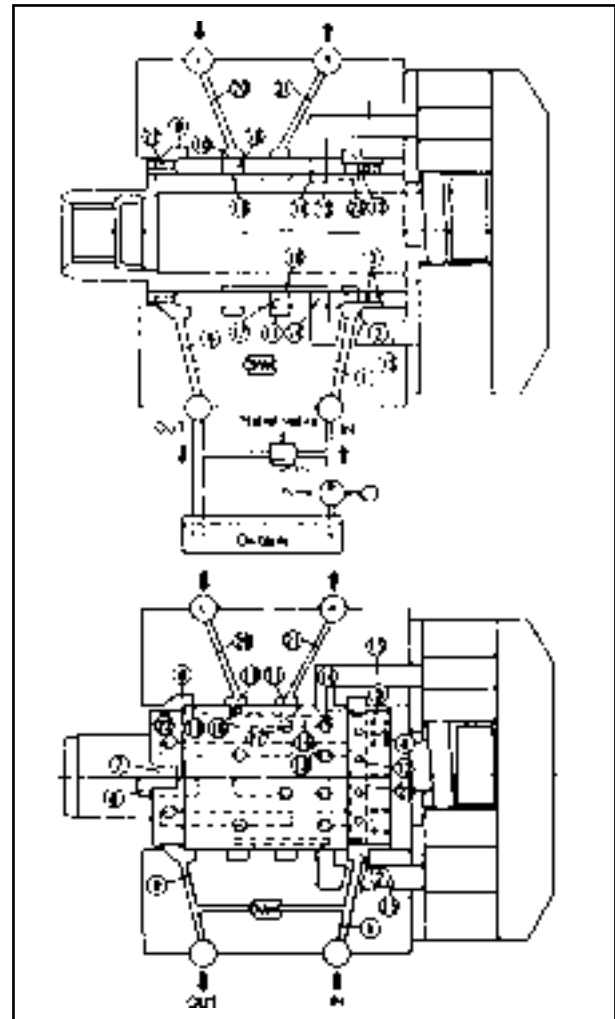

Fig. 5.8

(2) Relationship between the rotating speed and operating force of the steering wheel

The force required to operate the orbitrol is basically a valve operating force (the force required to compress the centering spring: 2.9 N-m {0.3 kgf-m} [2.14 lbf-ft]). That is, there is no mechanical linkage between the steering wheel and the tires, and thus the operating force of the steering wheel remains constant regardless of the rotating speed of the steering wheel. The discharge of oil from the orbitrol rotor to the steering cylinder is 96 cc/revolution.

(3) Neutral feedback of orbitrol

The neutral feedback function of the orbitrol is performed by the valve switching over the oil passages according to the reaction force of the centering spring. (If the steering wheel is turned and then released with the engine turned off, it will automatically return to the straight-ahead position.) Should the neutral feedback not function properly, the steering wheel might turn by itself when the operator does not turn it.

(4) When the pump fails to operate normally

If the pump fails to supply pressure oil to the orbitrol, the orbitrol can serve as an emergency manual steering device. Even if the orbitrol does not receive pressure oil from the pump, you can rotate the spool by turning the steering wheel. However, when the spool turns 8°, it hits against the cross pin, which in turn turns the rotor through the drive shaft. This way, the metering device of the orbitrol works as a hand pump to send oil to the steering cylinder. At this time, the check valve provided between the return port and the suction port opens to allow the oil to flow from the cylinder to the suction side, making it possible to steer the truck manually.

5.1.4 POWER CYLINDER

The power cylinder is attached to the steering axle and operated by oil from the orbitrol. The cylinder body is secured to the axle, with both ends of the piston rod connected to the knuckles with joints.

The cylinder cap has a bushing, an oil seal, and a dust seal, and is assembled on the cylinder with two bolts.

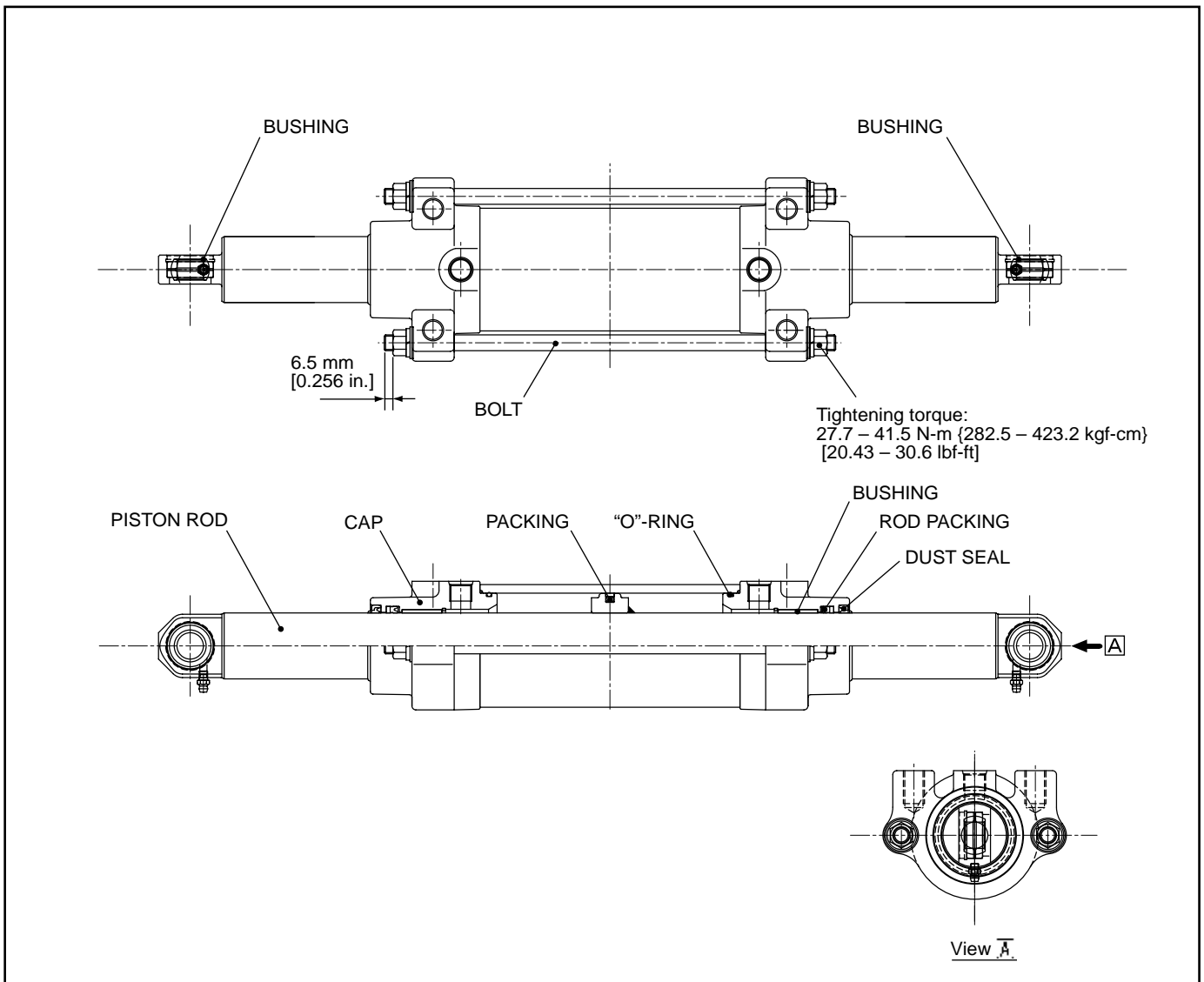

Fig. 5.9 Power Cylinder

5.1.5 STEERING WHEEL DEVIATION CONTROL

The orbitrol type steering system has a drawback that the steering wheel operating angle does not agree with the rotational angle of the knuckle exactly. In particular, the steering wheel may move gradually away from the center position, which the operator wants to hold while traveling.

To correct the drawback, the truck has a steering wheel deviation control unit consisting of an EPACS controller, a compensation valve, and a tire angle sensor.

The steering angle sensor is located on top of the left-side king pin of the rear axle.

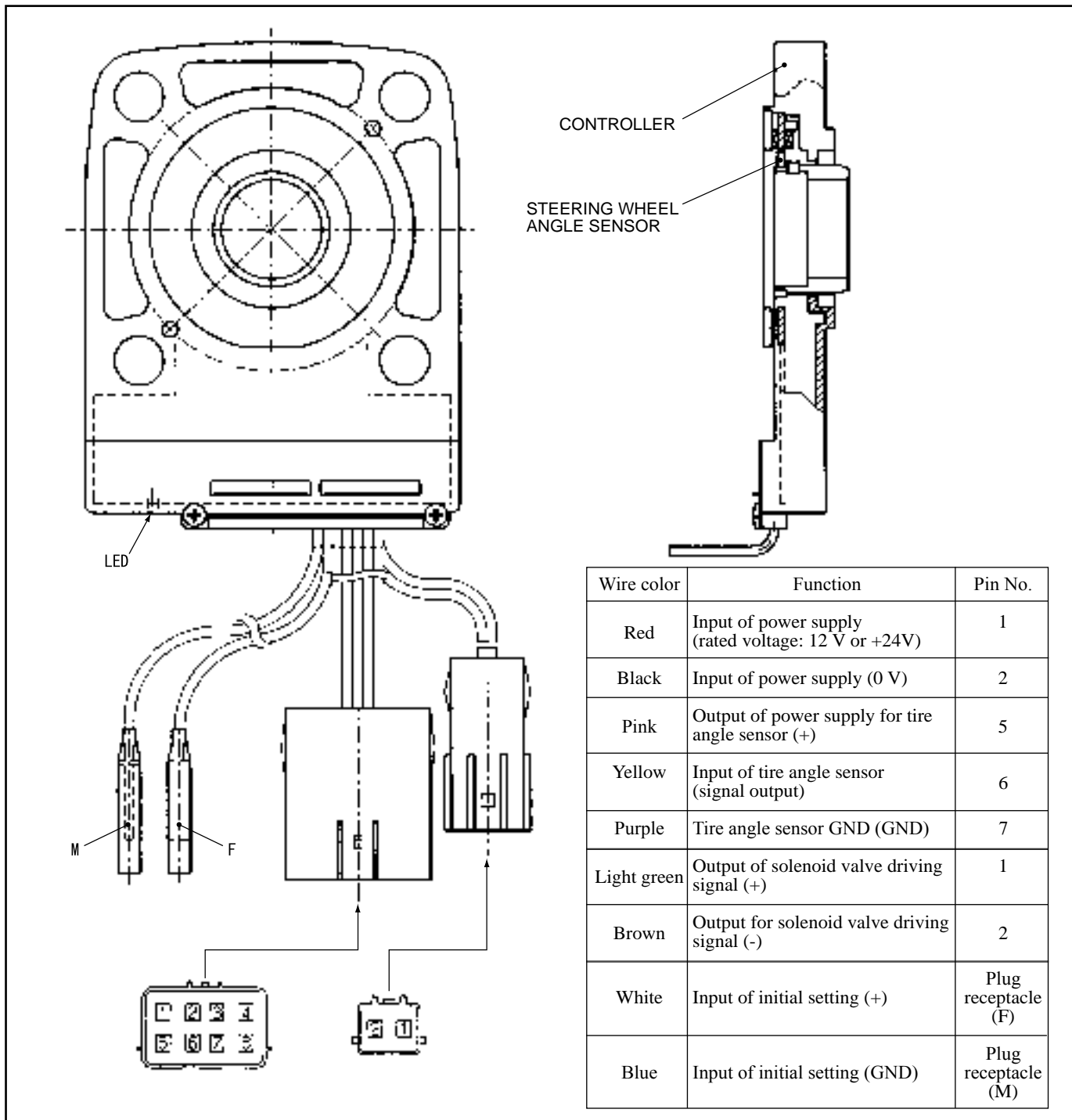
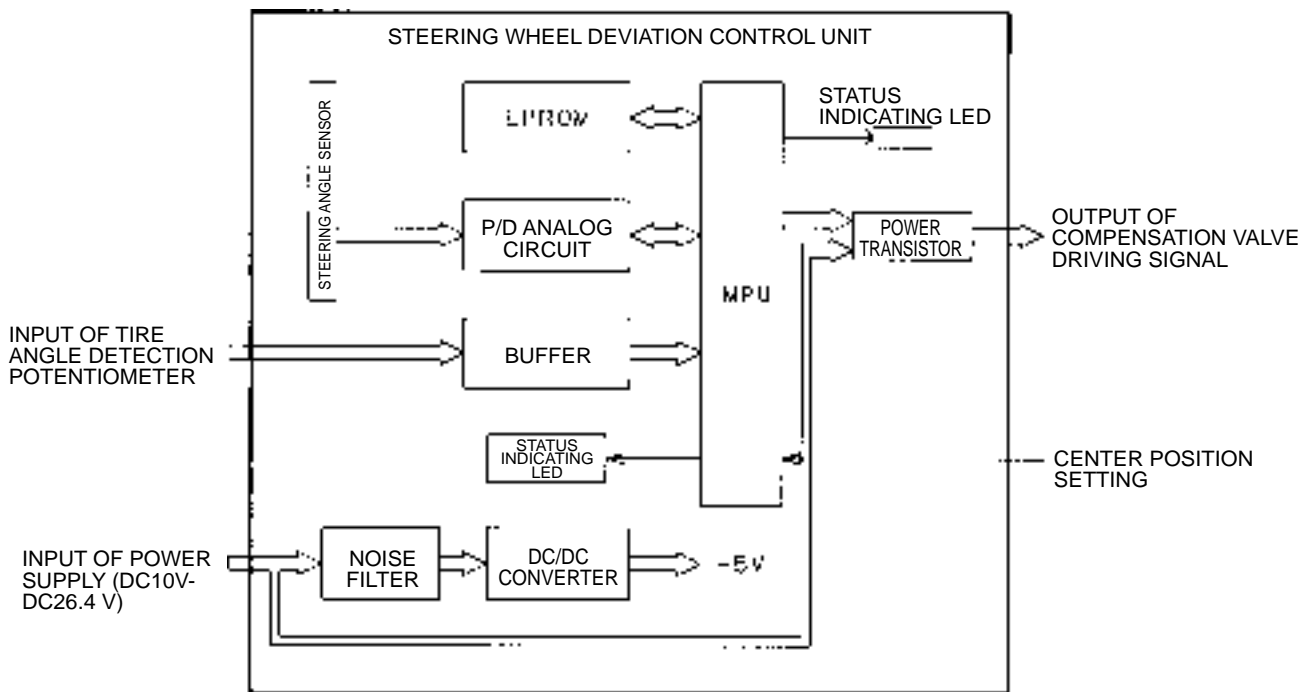
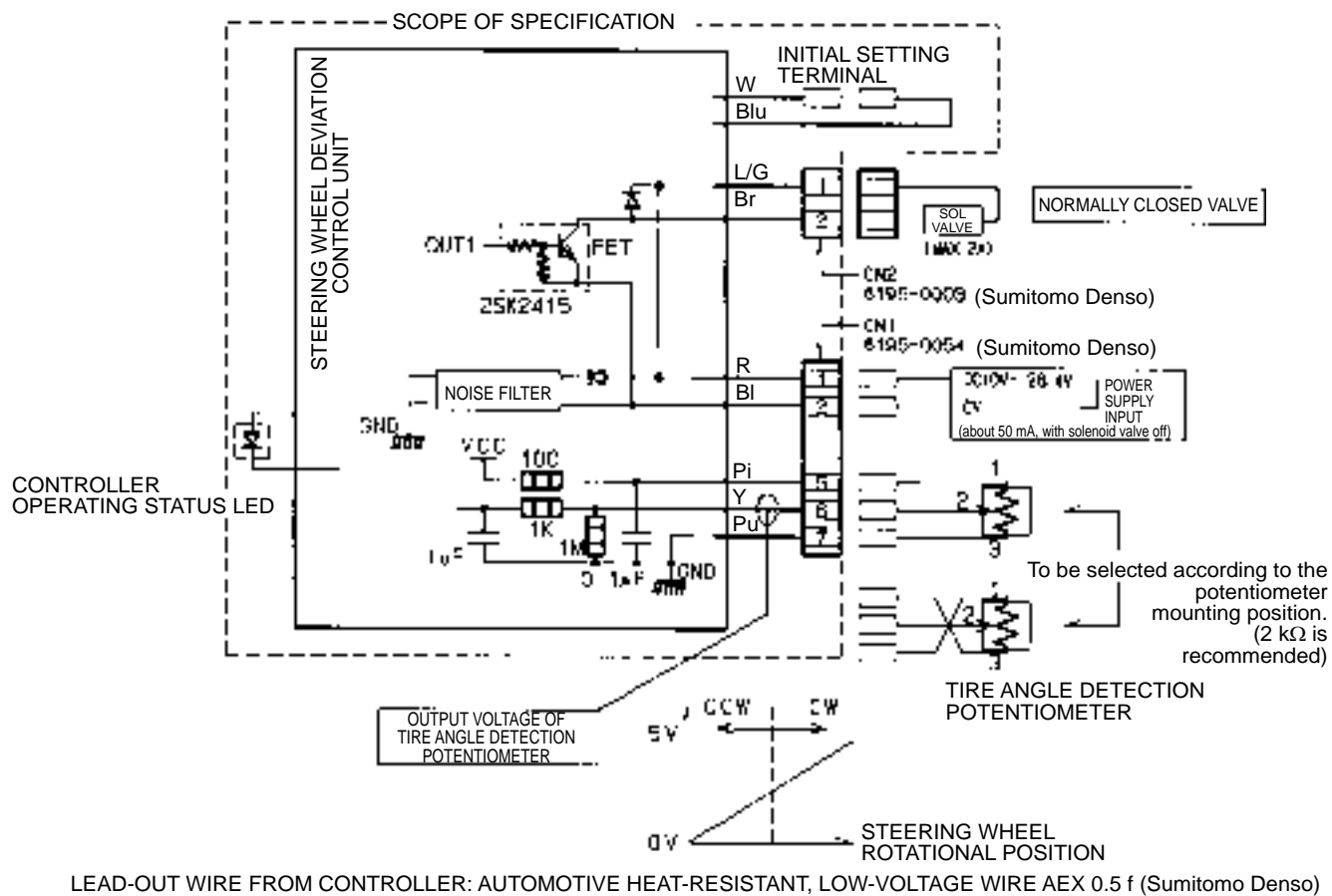

Fig. 5.10 EPACS Controller

(1) Schematic diagram



(2) Connection diagram



LEAD-OUT WIRE FROM CONTROLLER: AUTOMOTIVE HEAT-RESISTANT, LOW-VOLTAGE WIRE AEX 0.5 f (Sumitomo Denso)

Fig. 5.11 Schematic and Connection Diagrams

(3) How to set the center position of the steering wheel

- 1 Turn off the key switch and connect the plug receptacles M and F shown in Figure 5.10.
- 2 Turn the key switch on.
- 3 Make sure the LED blinks once and then repeats it.
If the LED blinks three or four times and stays off for a while and then repeats this cycle, it indicates that the steering wheel angle sensor or tire angle sensor is defective.
(See (4) Operating status LED.)
- 4 Put the steering wheel and the tires in the straight-ahead position.
(You can skip this step if the truck is in the straight-ahead position before the key switch is turned on in step 2.)
- 5 With the key switch turned ON, disconnect the plug receptacles from each other.
- 6 Make sure that the LED blinks twice continuously and repeats it.
- 7 Turn the steering wheel from center to clockwise end, turn it to counterclockwise end, and then return to the center position. Caution should be exercised not to allow the tires to slip at each of the turning ends. You cannot complete the setting if the steering wheel is not turned more than 1.5 turns from center to end in each direction.
- 8 Make sure the LED comes on. If the LED does not stay on, but blinks twice and repeats it, start all over again.

(4) Operating status LED

	Operating status of controller	LED
1	<ul style="list-style-type: none"> • Centering is not yet finished. • Controller has been initialized with plug receptacles connected. 	1 blink
2	<ul style="list-style-type: none"> • Initial setting mode selected • If a setting error is detected, you cannot exit the initial setting mode. (*1) 	2 blinks
3	<ul style="list-style-type: none"> • Initial setting completed (ready for operation) 	LED stays on (*2)
4	Steering wheel sensor defective <ul style="list-style-type: none"> • Sensor coil broken 	3 blinks
5	Tire angle detection potentiometer defective <ul style="list-style-type: none"> • Wire leading to tire angle sensor or controller is broken. • Wire leading to tire angle sensor or controller is shorted. (*3) 	4 blinks
6	<ul style="list-style-type: none"> • Power voltage is lower than rated voltage. • CPU inside controller is defective. • Controller is being initialized 	Off

(*1) Setting error:

A setting error occurs if the steering wheel is not turned more than 1.5 turns in each of the clockwise and counterclockwise directions or if the steering wheel is returned in midstream through rotation from center to end or vice versa.

(*2) No error is detected (LED stays on.).

(*3) 1: Shorting between +V terminal and signal output terminal of tire angle sensor

2: Steering wheel angle sensor has one of the following errors:

- Shorting between sin drive signal wires
- Shorting between cos signal wires
- Shorting between sin signal wires

3: Solenoid valve driving FET is defective.

6. HYDRAULIC SYSTEM

Truck Model			FG20 _{T3} FHG20 _{T3} FG25 _{T3} FHG25 _{T3} FG30 _{T3} FHG30 _{T3} FD30 _{T3} FD35 _{T3S}			FHD20 _{T3A} FHD25 _{T3A} FHD30 _{T3A}	FG35 _{T3S}	
Item	FHG15 _{T3} FHG18 _{T3}	FHD15 _{T3} FHD18 _{T3}			FD20 _{T3} FD25 _{T3}			
Main pump								
Type			Gear type					
Model name	KFP2328	KFP2325	SGP1A30.8	SGP1A27	SGP1A36	SGP1A32		
Discharge	28.2 cm ³ /rev	24.5 cm ³ /rev	30.8 cm ³ /rev	27.8 cm ³ /rev	36.6 cm ³ /rev	33.2 cm ³ /rev		
Control valve								
Type	2-spool sliding type, with relief valve, flow divider and tilt-lock valve							
Model name	KVMF-70VPF			MSV04A				
Pressure setting								
Main	17.7 MPa {180 kgf/cm ² } [2567 psi]							
Steering	6.9 MPa {70 kgf/cm ² } [1000 psi]			8.8 MPa {90 kgf/cm ² } [1276 psi]				
Lift cylinder								
Type			Single-acting piston					
Cylinder bore	45 mm [1.77 in.]		2 - 2.5 t: 50 mm [1.97 in.] 3 t: 55 mm [2.17 in.] 3.5 t: 60 mm [2.36 in.]					
Stroke			1495 mm [58.9 in.]					
Tilt cylinder								
Type			Double-acting piston					
Cylinder bore	65 mm [2.56 in.]		80 mm [3.15 in.]					
Rod diameter	30 mm [1.18 in.]		35 mm [1.38 in.]					
Stroke	130 mm [5.12 in.]		128 mm [5.04 in.]					
Oil tank								
Capacity	21 liters [5.55 U.S. gal]			32 liters [8.45 gal]				

6.1 GENERAL DESCRIPTION

The hydraulic system consists of a main pump, a control valve, lift cylinders and tilt cylinders. The oil is supplied from the tank at the right side of the frame.

6.1.1 MAIN PUMP

The main pump is a gear type directly driven by the engine PTO device and picks up oil from the oil tank and sends to the control valve.

The main pump consists of a pump body, a pair of gears, bushings and packings. This pump uses pressure-balanced bearings and a special lubrication method to minimize the clearance of the gear flank.

The pressure-balanced method is to press the pressure plate toward the gear side by introducing part of the discharge oil between the pressure plate and the pump body.

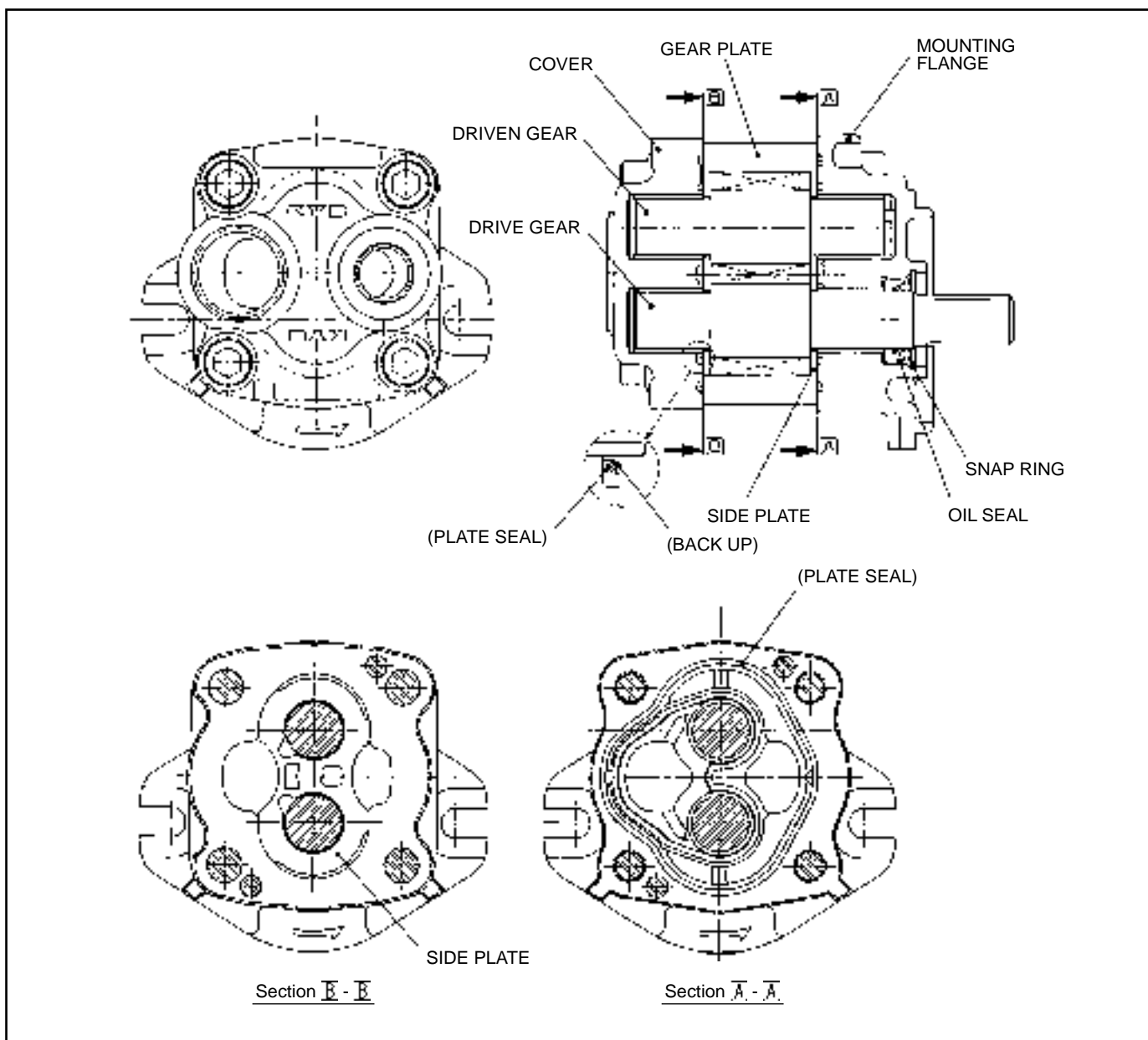
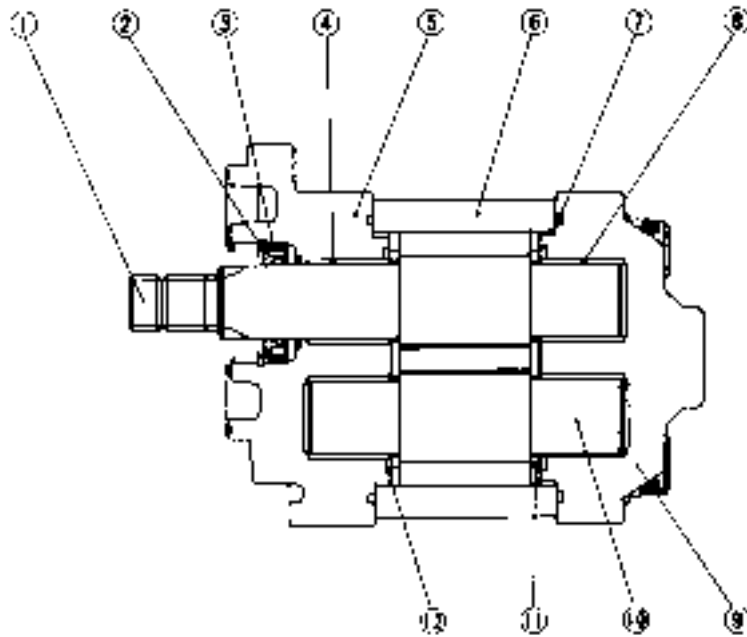

Fig. 6.1 Main Pump (Trucks with capacities from 1.5 to 1.75 tons)



- | | |
|----------------|-----------------|
| 1. DRIVE GEAR | 7. GASKET |
| 2. SNAP RING | 8. BUSHING |
| 3. OIL SEAL | 9. REAR COVER |
| 4. BUSHING | 10. DRIVEN GEAR |
| 5. FRONT COVER | 11. SIDE PLATE |
| 6. BODY | 12. GASKET |

Fig. 6.2 Main Pump (Trucks with capacities from 2.0 to 3.5 tons)

(1) Oil flow

The oil which has flowed through the inlet port in the rear cover then enters the chamber formed by the tooth spaces of the gears, side plates, and the pump body, and flows along the peripheries of the gears out of the discharge port.

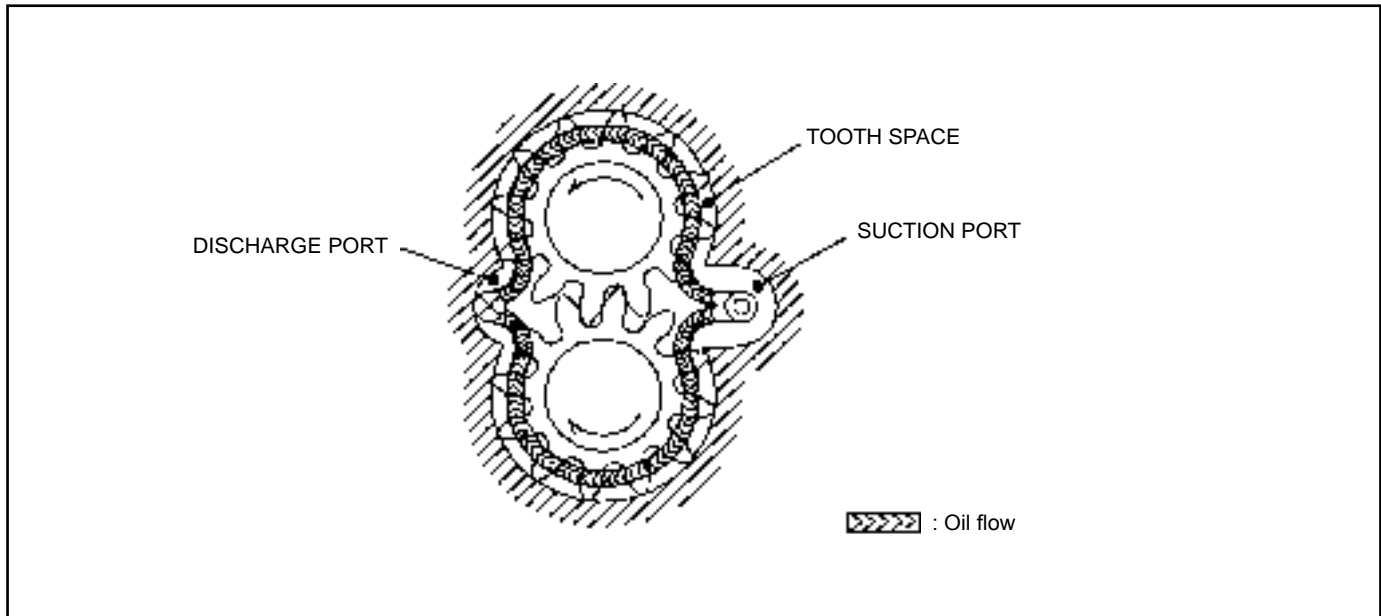

Fig. 6.3 Hydraulic Oil Flow

(2) Pressure balance

While the pump is not operating or the discharge pressure is low, the side plates are pressed against the gears' side faces by the rubber gasket. When the discharge pressure becomes high, a force which repels the side plates acts on the shaded section in Fig. 6.4. At the same time, the oil pressure also acts on the back side of the side plates, pressing the shaded section in Fig. 6.5. The shapes and surface areas of both shaded sections are almost the same, so that the side plates are always pressed against the sides faces of the gears with a constant elastic force, regardless of the discharge pressure of the pump.

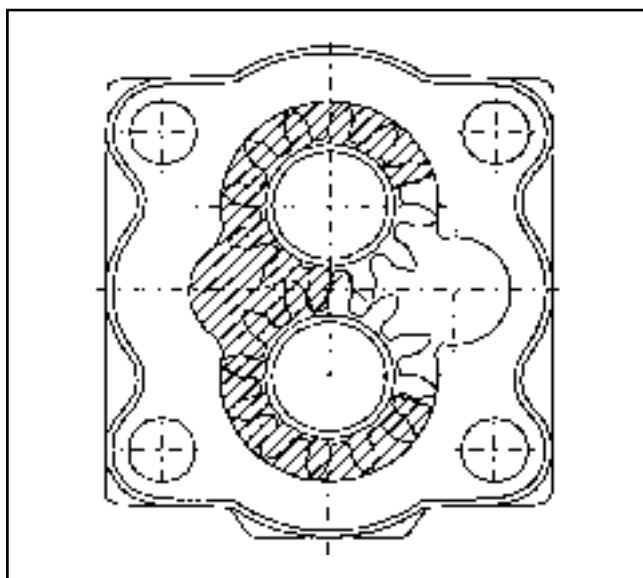

Fig. 6.4 Pressure Distribution on Side-Plate Side

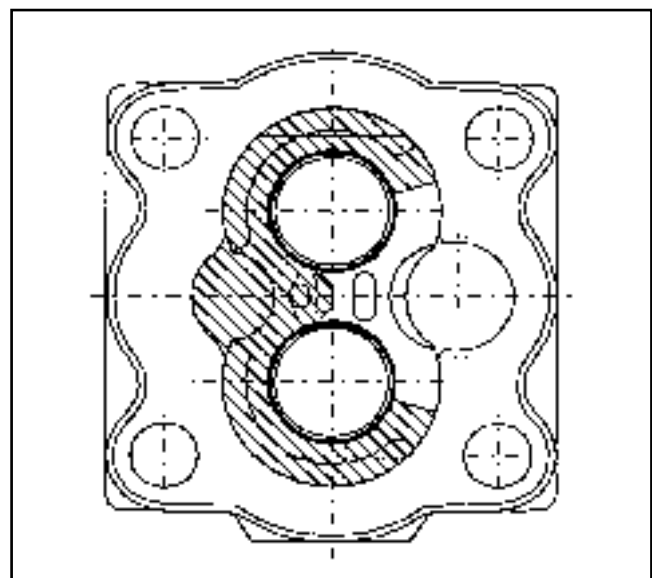

Fig. 6.5 Pressure Distribution on Gear Side

(3) Body wiper

While the discharge pressure is low, the centers of the gears are almost aligned with the centers of the pump body holes, maintaining the radial clearance which is determined by machined size. When the discharge pressure increases, the gears are pushed toward the low-pressure side by the clearance between the gear and bearing and a deflection of the shaft, to make the gear teeth to contact with the pump body. During this process, the cast pump body is worn away, because the gears, which are usually heat treated, are harder than the pump body. This is called “body wiper.”

In order to keep the optimum radial clearance of gears when loaded, the pump is run-in at a little higher pressure than the rated pressure before it is delivered to the customer. Also, the pump is tested for discharge and specified torque.

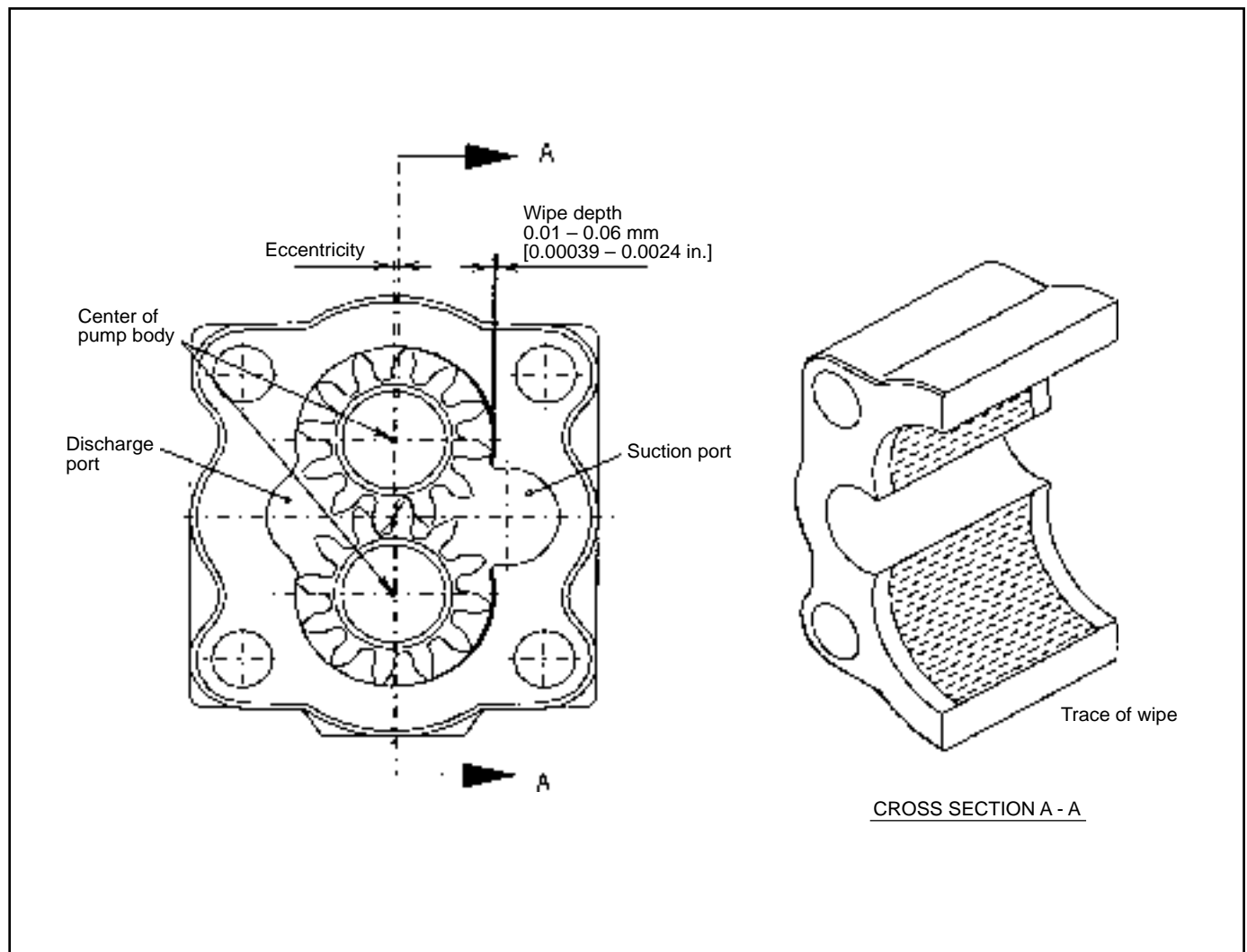

Fig. 6.6 Body Wiper

6.1.2 CONTROL VALVE

■ 1.5 to 1.75 tons

The control valve consists of two types of spool sections assembled with three bolts as shown in Figure 6.7.

The lift spool section contains a main relief valve, a flow priority valve and a PF relief valve.

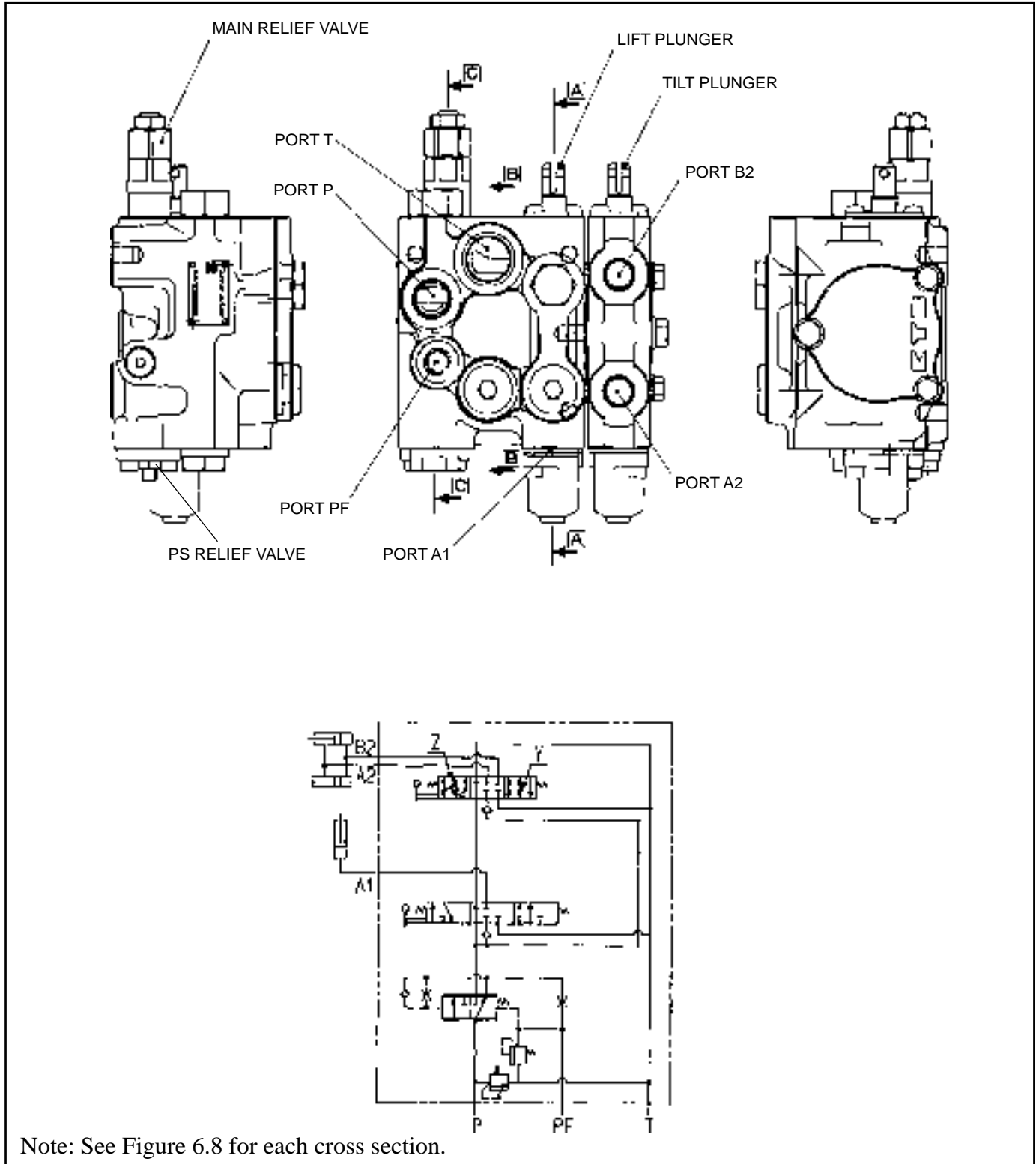

Note: See Figure 6.8 for each cross section.

Fig. 6.7 Control Valve (Trucks with capacities from 1.5 to 1.75 tons)

(1) Lift spool section

The lift spool section consists of a lift plunger, a PF relief valve which controls the steering circuit oil pressure, and a flow divider valve which distributes the oil flow from the main pump into both the load handling circuit and the steering circuit.

The lift spool section is also provided with a cartridge type relief valve which sets the load handling circuit oil pressure and the steering circuit oil pressure.

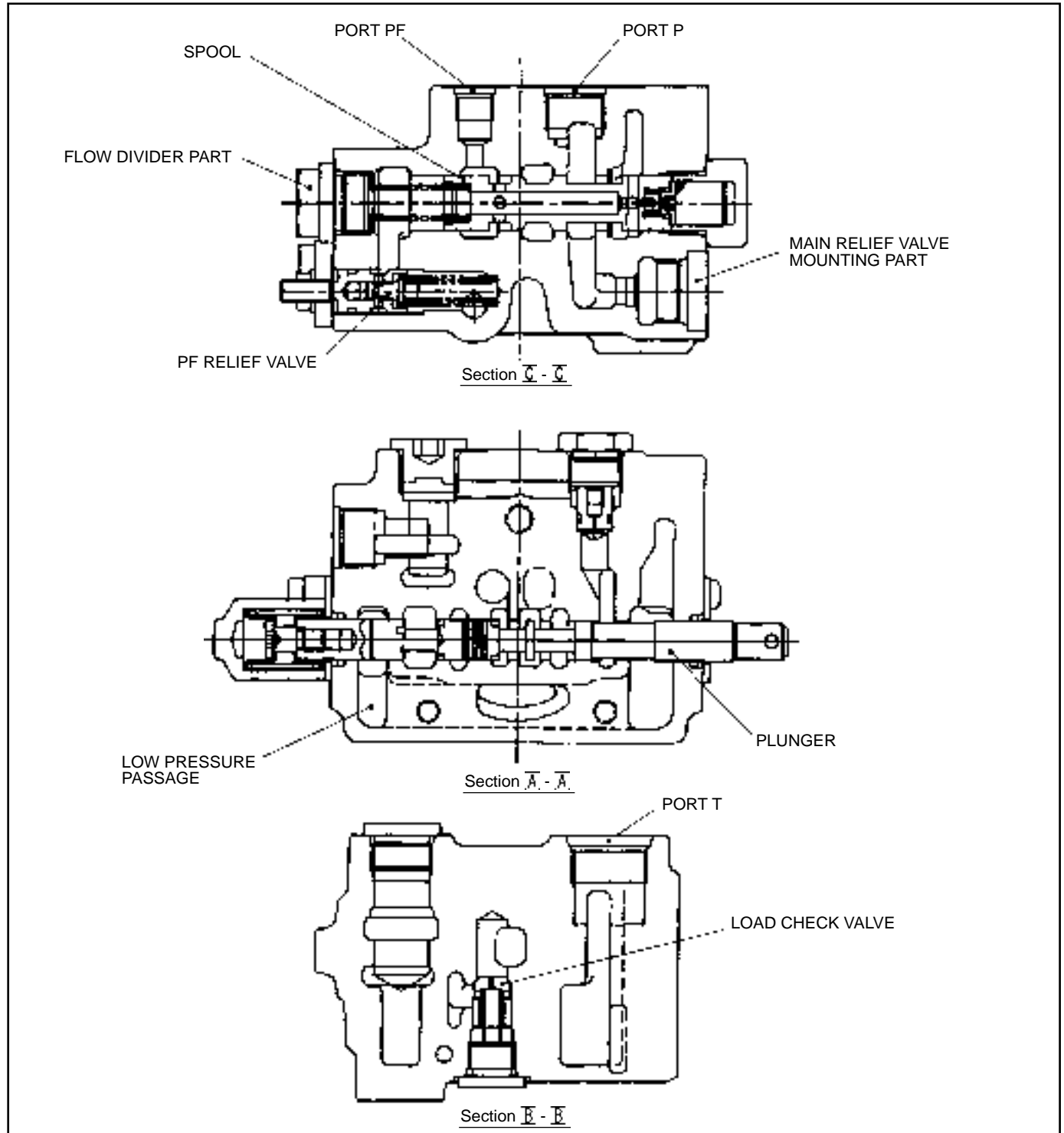

Fig. 6.8 Lift Spool Section

■ Main relief valve operation

(a) The oil in the high-pressure oil passage HP flows through the oil in the piston C to act on two different surface areas \bar{A} and \bar{E} , so that the poppets D and K are securely seated.

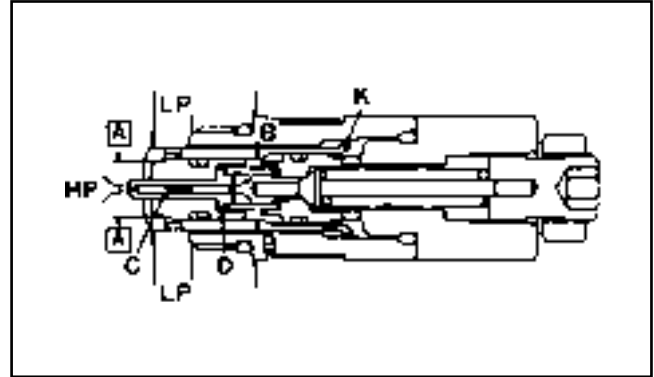

Fig. 6.9

(b) When the oil pressure in the high-pressure oil passage HP reaches to the preset pilot spring force, the pilot poppet E opens to allow the oil to flow around the poppet, passing through the drilled hole, to the low-pressure side LP.

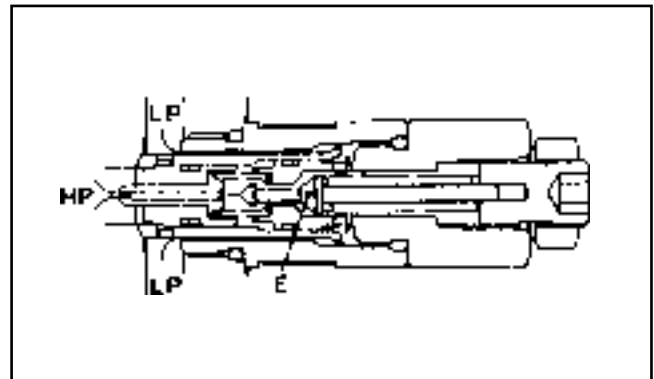

Fig. 6.10

(c) When the pilot poppet E opens, the pressure at the back of the poppet D drops to cause pressure differential between the high-pressure side HP and the low-pressure side, so that the poppet D is opened to allow the oil to flow directly to the low-pressure oil passage LP.

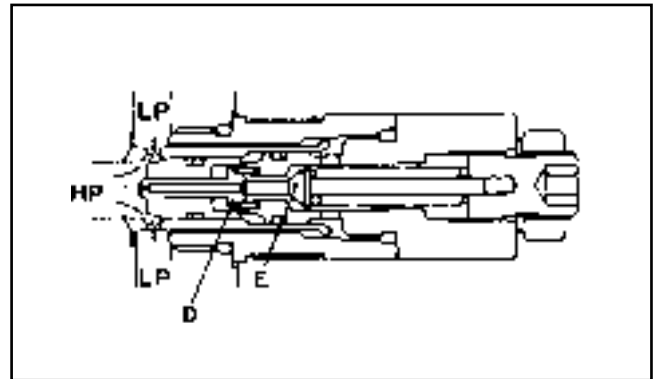

Fig. 6.11

(d) If the pressure in the high-pressure oil passage HP is lower than the pressure in the low-pressure oil passage LP, the poppet D opens due to the difference in area between \bar{A} and \bar{E} to allow enough oil to flow from the low-pressure oil passage LP into the high-pressure oil passage HP to fill the space.

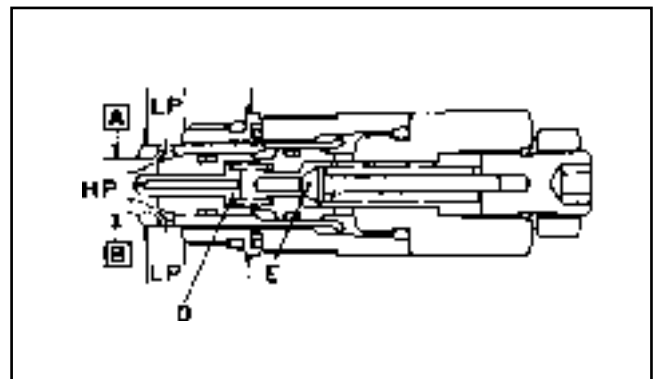

Fig. 6.12

(2) Tilt spool section

Figure 6.13 shows sectional views of the tilt spool section. The plunger attached to the housing is kept in neutral by the return spring. The plunger incorporates a tilt lock valve.

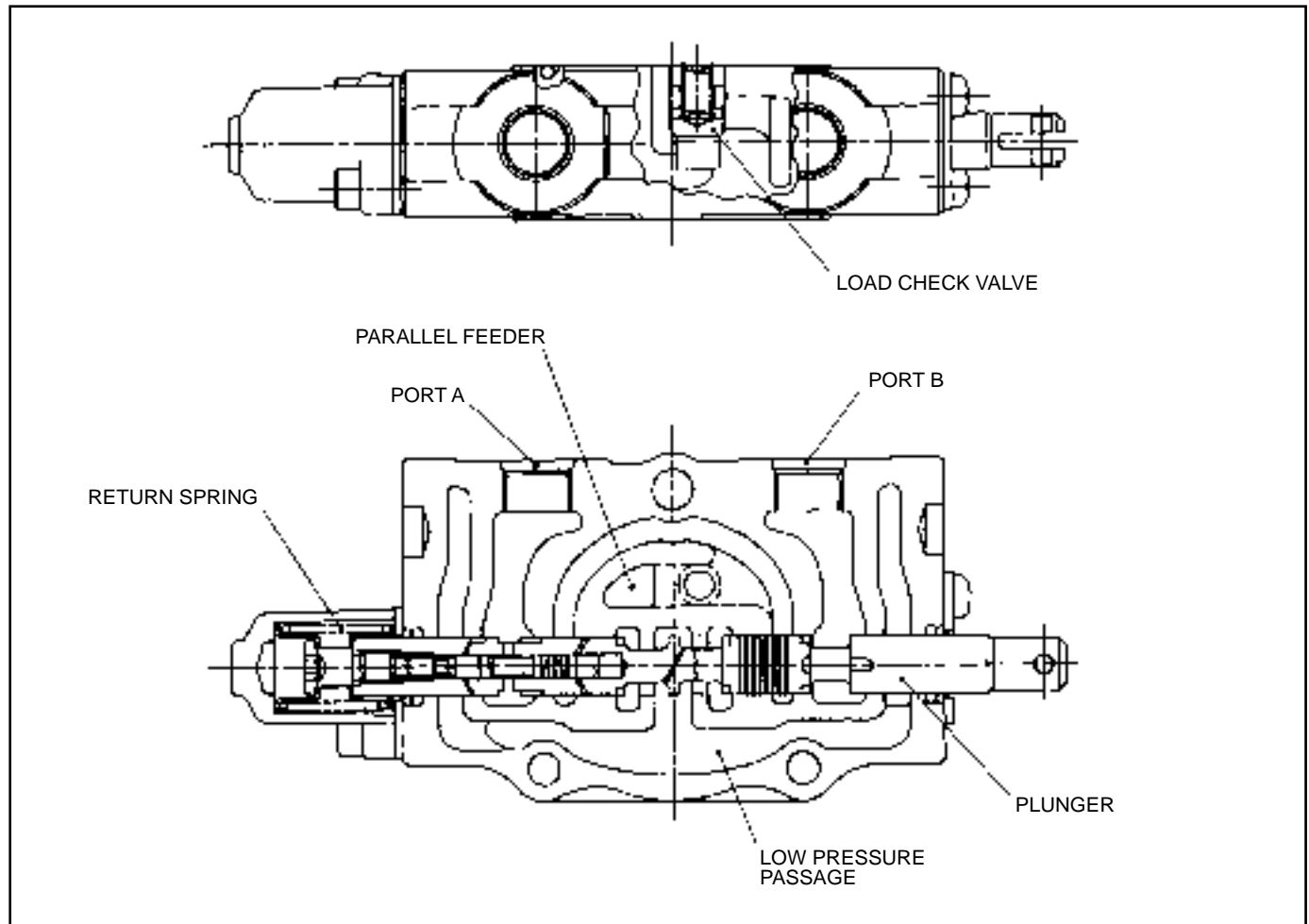

Fig. 6.13 Tilt Spool Section

■ **Tilt spool section operation**

(a) In neutral

When the plunger is in neutral position, oil discharged from the pump returns to the tank by way of the neutral passage.

(b) Plunger pushed in

When the plunger is pushed in, it blocks up the neutral passage so the oil runs to the cylinder port “B” by pushing up the load check valve. The oil returning from the cylinder port “A” runs to the low pressure passage through which it then flows into the tank. Then plunger is put back in neutral position by the return spring.

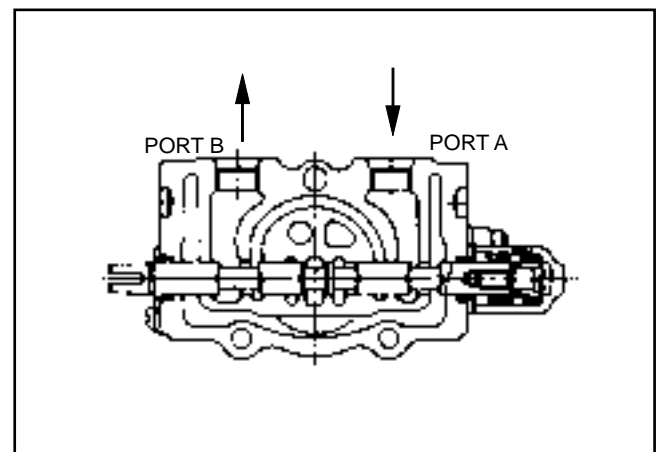

Fig. 6.14 Pushed In

(c) Plunger pulled out

When the plunger is pulled out, the neutral oil passage is blocked up. The oil from the parallel feeder pushes open the load check valve and flows to the cylinder port A.

The oil returning from the cylinder port B flows to the low-pressure oil passage and back into the oil tank. The plunger is pushed back to neutral by the return spring.

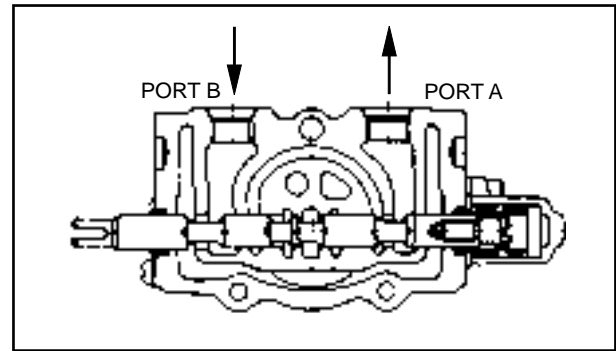

Fig. 6.15 Pulled Out

■ Tilt lock valve operation

(a) Plunger pulled out

With the plunger pulled out, the oil flows in the same manner as in shown Figure 6.15.

Figure 6.16 shows a spool section in neutral, with a tilt lock valve incorporated inside.

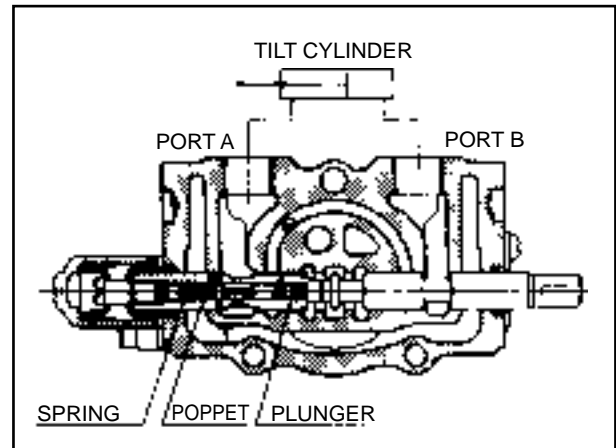

Fig. 6.16 In Neutral

(b) Plunger pushed in (pump in operation)

When the plunger is pushed in, the oil from the pump flows from the cylinder port B into the cylinder. The oil from the cylinder enters the hole (A) in the plunger to move the poppet. Therefore, the oil returning from the cylinder flows through the holes (A) and (B) in the plunger, passing through the low-pressure oil passage, back into the tank.

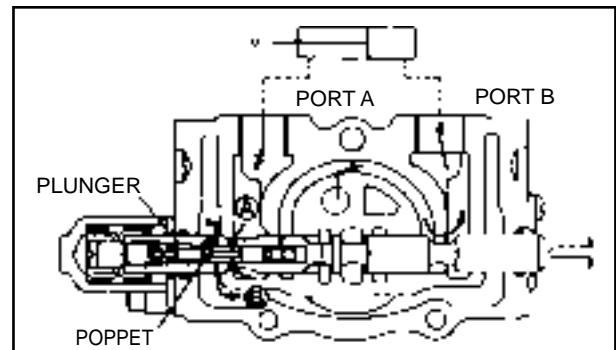

Fig. 6.17

(c) Plunger pushed in (pump at rest)

If the plunger is pushed in with the pump at rest, the oil won't flow to the cylinder port B and the pressure at area (P) also won't rise. The poppet does not move so that the cylinder won't move and thus the oil at the cylinder port A also does not return back into the tank.

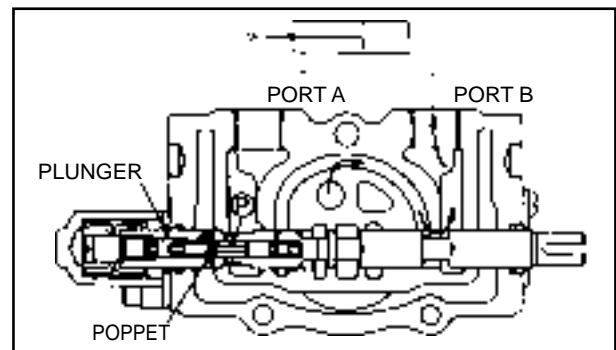

Fig. 6.18

■ 2.0 to 3.5 tons

The control valve consists of FDM front and rear covers and a combination valve, which are assembled with three bolts.

The FDM front cover contains a main relief valve, a flow priority valve and a PF relief valve. The combination valve is composed of a lift section and a tilt section.

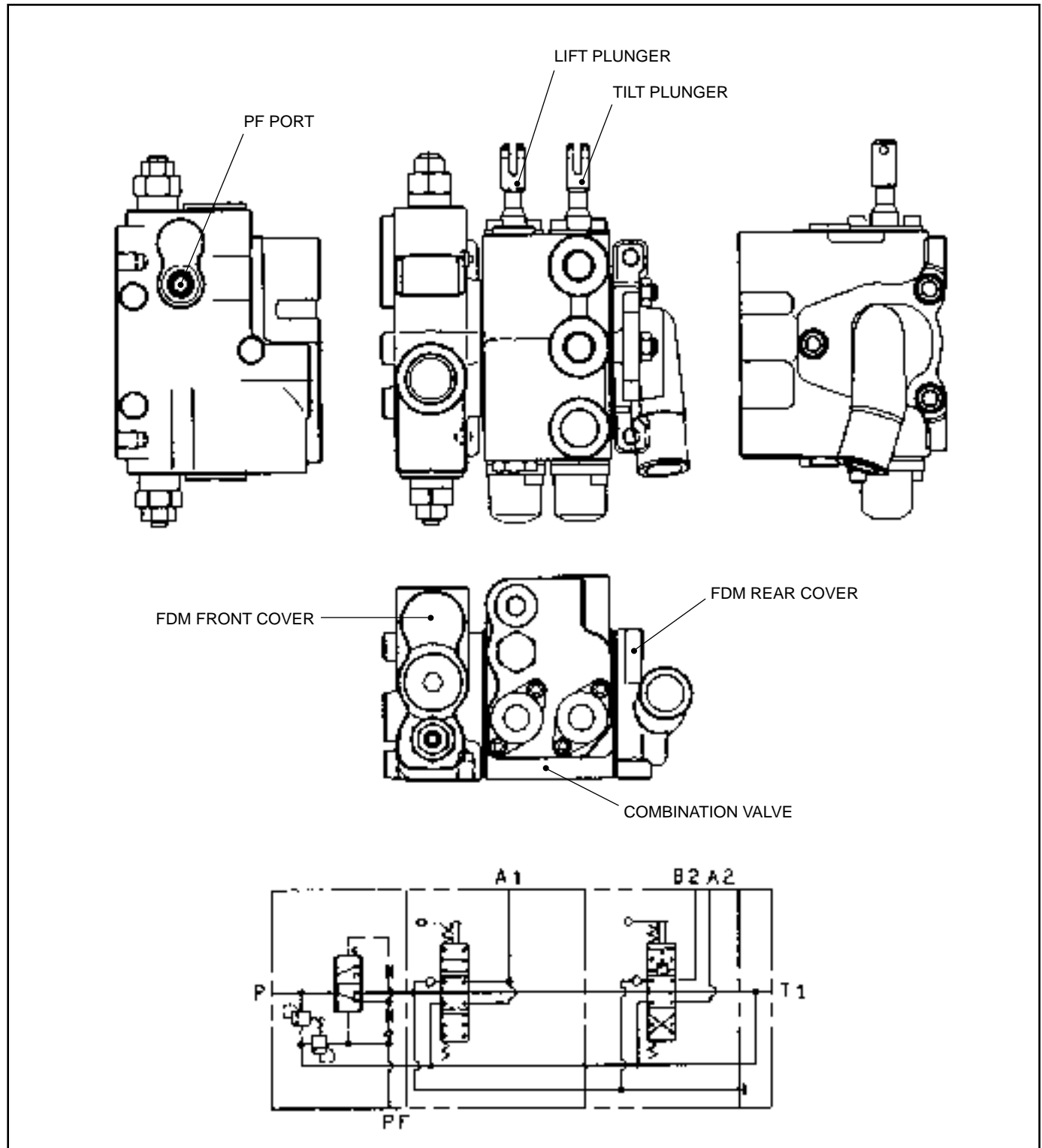

Fig. 6.19 Control Valve (Trucks with capacities from 2.0 to 3.5 tons)

(1) Operation of flow priority valve

The flow priority valve receives a single stream of oil through the P port and divides it into separate output streams: the priority flow (PF flow) of a constant flow setting and the excess flow (MF flow). The PF flow is supplied to the steering system and the MF flow to the load handling system.

The oil coming through the pump port (P port) flows, passing through the PF throttle hole, the control orifice and load check in the FD spool, to the PF port. As the flow rate of oil coming through the P port increases, the pressure differential across the control orifice also increases. This moves the FD spool, both ends of which receive the pressure across the control orifice, into the direction that closes the PF throttle hole, thus reducing the PF flow. As a result, the pressure differential across the control orifice also drops so that the priority flow is maintained at the flow setting determined by both the control orifice and set spring.

(a) MF flow pressure is lower than PF flow pressure (during steering)

When the steering wheel is turned, the PF flow pressure increases and thus the entire oil pressure of the hydraulic system also increases. This allows more oil to flow to the MF flow side because it is lower in pressure than the PF flow side. For this reason, the flow rate of oil to the control orifice drops to create a pressure differential across the control orifice, thus shifting the FD spool into the direction that closes the MF throttle hole so that the pressure differential across the control orifice is maintained to keep the priority flow at the fixed flow setting. (See Figure 6.20.)

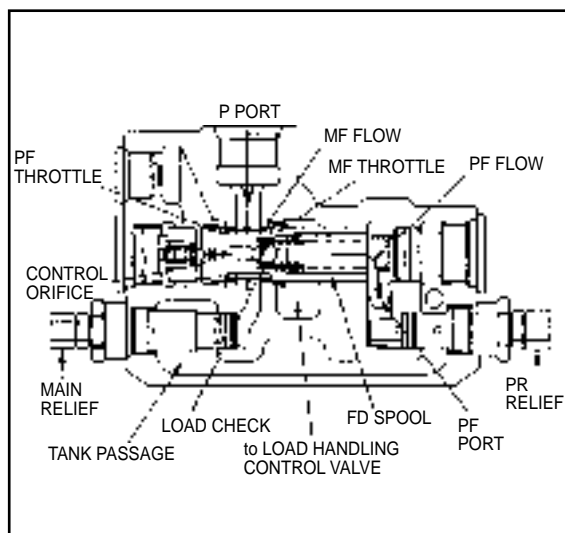

Fig. 6.20 (MF pressure < PF pressure)

(b) MF low pressure is higher than PF flow pressure (during load handling)

When the load handling means is operated, the MF flow pressure increases and thus the entire oil pressure of the hydraulic system also increases. Since the PF flow pressure is lower than the MF flow pressure, the priority flow begins to increase. Therefore, the pressure differential across the control orifice increases so that the FD spool moves in the direction that closes the PF throttle hole, to keep the control flow constant. (See Figure 6.21.)

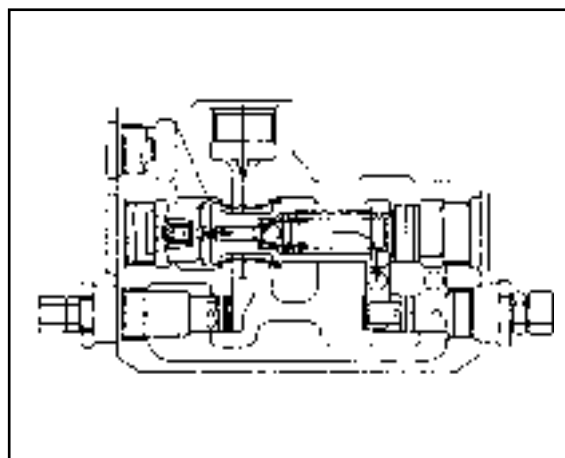

Fig. 6.21 (MF pressure > PF pressure)

(2) Lift section

(a) In neutral

The oil discharged from the pump flows through the unload passage back to the oil tank. The port A1 is blocked so that no pressure oil is supplied to the lift cylinders. (See Figure 6.22.)

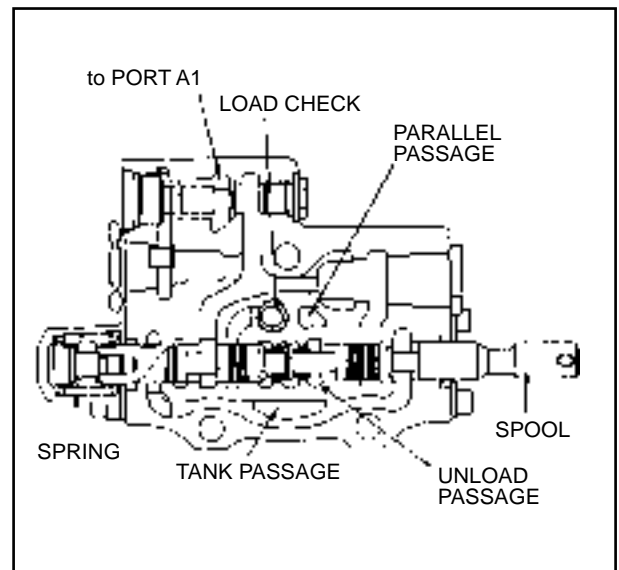

Fig. 6.22

(b) Spool pulled out (when forks are lifted)

The unload passage is closed so that the oil from the pump flows through the parallel passage to push open the load check and lock poppet and enters the lift cylinders through the port A1. The spool is returned to neutral by the return spring. (See Figure 6.23.)

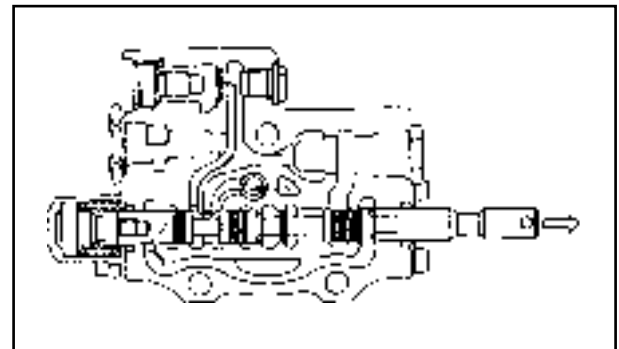

Fig. 6.23

(c) Spool pushed in (when forks are lowered)

When the spool is pushed in, the unload passage is not closed and thus the oil from the pump returns to the tank passage. The oil that has the lift cylinders through the port A1 flows to the return passage, returning into the oil tank. The spool is returned to neutral by the return spring. (See Figure 6.24.)

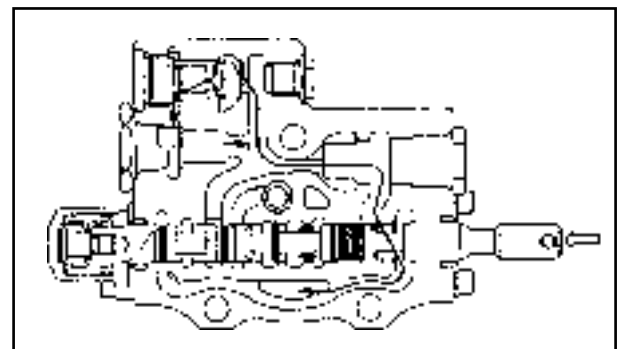

Fig. 6.24

(3) Tilt section

(a) In neutral

The oil discharged from the pump flows, passing through the unload passage, back into the oil tank. The ports A2 and B2 are blocked so that the no pressure oil is supplied to the tilt cylinders.

(b) Spool pulled out (when upright is tilted back)

When the unload passage is closed, the oil from the pump flows through the parallel passage to push open the load check and enters the tilt cylinders through the port A2. The oil returning from the tilt cylinders flows through the port B2 and tank passage, back into the oil tank.

If the load inside the tilt cylinders is higher than the relief valve pressure setting, the relief valve opens to allow oil to return into the tank passage. The spool is returned to neutral by the return spring. (See Figure 6.26.)

(c) Spool pushed in (when upright is tilted forward)

With the unload passage closed, the oil from the pump flows through the parallel passage to push open the load check and enters the tilt cylinders through the port B2. The oil returning from the tilt cylinders enters at the port A2, but is blocked by the tilt lock valve. However, as the oil pressure rises, the pilot spool moves in the direction that compresses the spring so that the oil at the port A2 flows through the oil passage inside the spool, back into the oil tank.

If the load inside the tilt cylinders is higher than the relief valve pressure setting, the relief valve opens to allow oil to return to the tank passage. The spool is returned to neutral by the return spring. (See Figure 6.27.)

(d) Tilt lock mechanism

The tilt spool is provided with a tilt lock mechanism that prevents the tilt cylinders from moving when the tilt lever is placed in the forward tilt position with no oil flow to the main valve.

If the spool is pushed in (the tilt lever is placed in the forward tilt position) with no oil flow from the pump, the oil at the loaded side inside each of the tilt cylinders tries to flow out the port A2. However, since no pilot pressure is supplied, the pilot spool does not move so that the return passage to the oil tank is closed. This prevents the tilt cylinders from operating. (See Figure 6.28.)

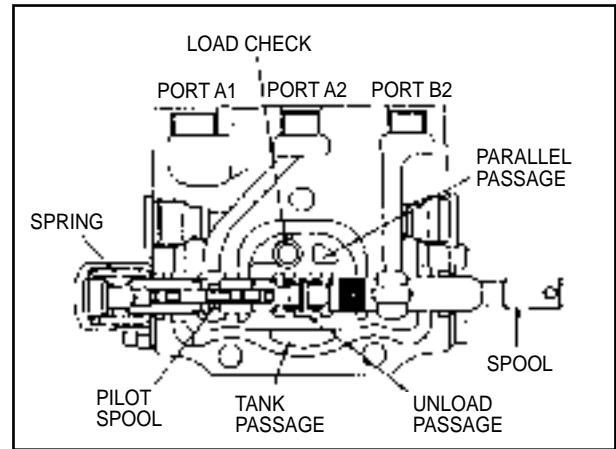

Fig. 6.25

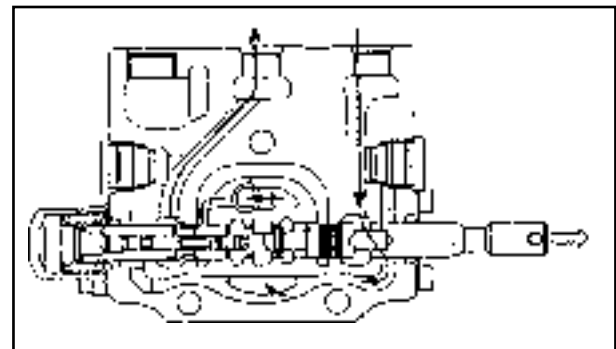

Fig. 6.26

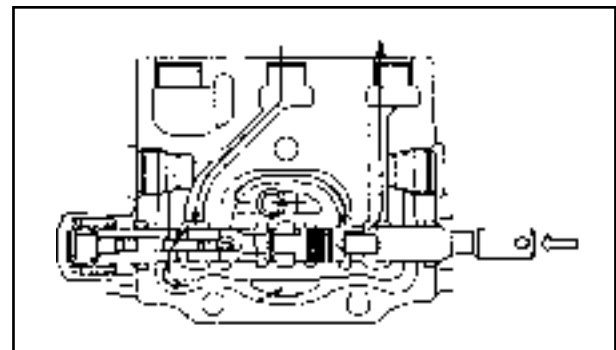

Fig. 6.27

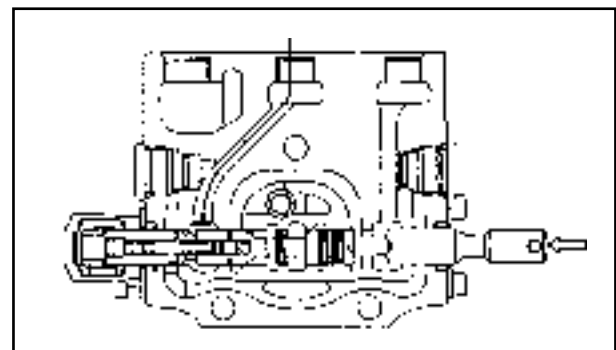

Fig. 6.28

(4) Accessory section (option)

(a) In neutral

The oil from the pump flows through the unload passage, back into the oil tank. The ports A and B are blocked so that no oil pressure is supplied to the cylinder. (See Figure 6.29.)

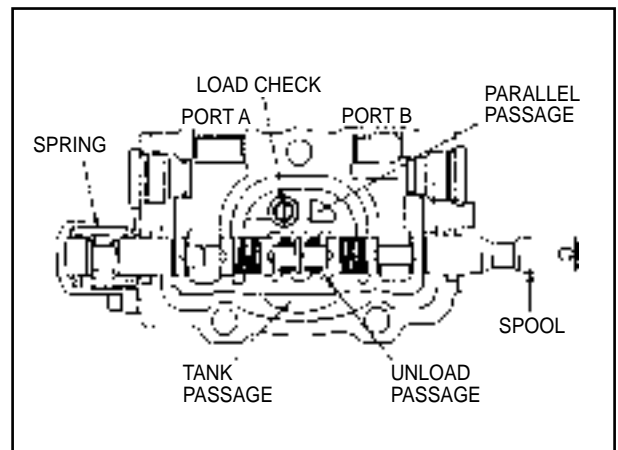

Fig. 6.29

(b) Spool pulled out

The unload passage is closed and the oil from the pump flows through the parallel passage to push open the load check and enters the cylinder through the port A. The oil returning from the cylinder flows through the port B, past the tank passage, back into the oil tank.

If the load inside the cylinder is higher than the relief valve pressure setting, the relief valve opens to allow oil to return into the oil tank. The spool is returned to neutral by the return spring. (See Figure 6.30.)

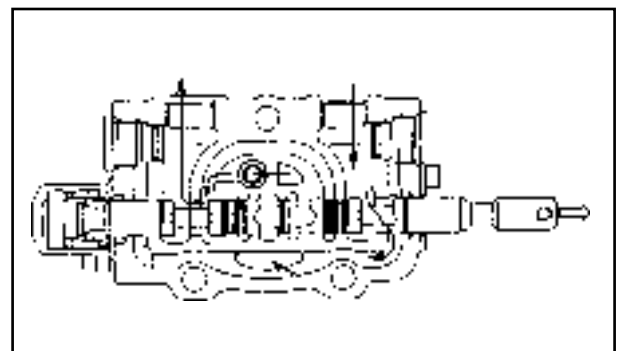

Fig. 6.30

(c) Spool pushed in

The unload passage is closed and the oil from the pump flows through the parallel passage to push open the load check and enters the cylinder through the port B. The oil returning from the cylinder flows through the port A, past the tank passage, back into the oil tank.

If the load inside the cylinder is higher than the relief valve pressure setting, the relief valve opens to allow oil to return to the tank passage. The spool is returned to neutral by the return spring. (See Figure 6.31.)

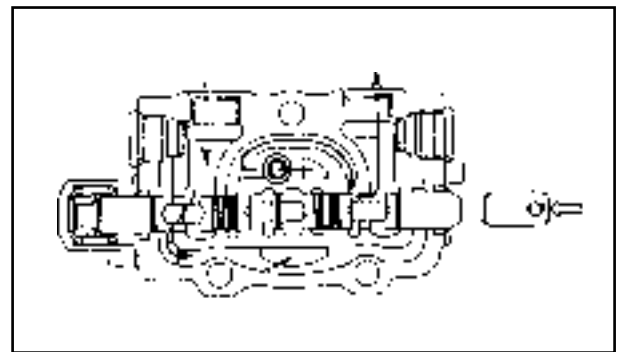

Fig. 6.31

(5) Operation of main relief valve

(a) When relief valve is closed

If the circuit oil pressure is lower than the relief valve pressure setting, the relief valve is closed.

The oil at the port P flows through the orifice in the poppet to fill the spring chamber.

The oil inside the spring chamber acts on the pilot poppet, which is however forced against the seat by spring pressure to block oil flow to the tank passage.

The main poppet is closely seated to the sleeve by both the spring force and the difference in area on which the oil pressure acts, to block the oil passage to the tank port. Therefore, all the oil sent into the circuit flows to the operating area. (See Figure 6.32.)

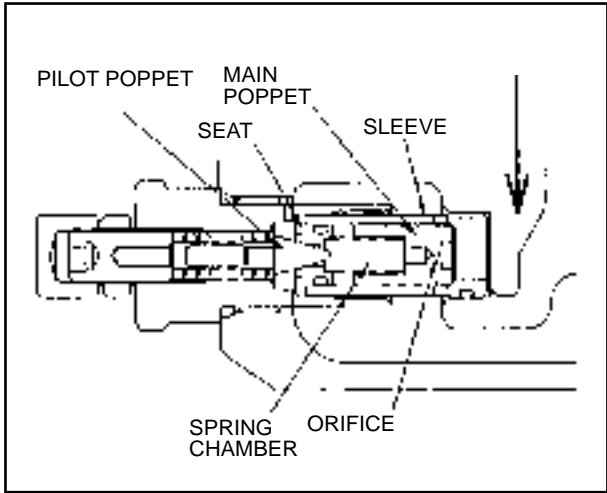

Fig. 6.32 Main Relief Valve (closed)

(b) When relief valve opens

If the circuit oil pressure becomes higher than the relief valve pressure setting, the relief valve opens.

That is, when the oil pressure in the circuit reaches the pilot poppet pressure setting, the pressure oil pushes up the pilot poppet to flow into the tank passage. This causes a pressure differential across the orifice in the main poppet to push open the main poppet to allow the oil to flow from the port P to the tank passage, thus controlling the oil pressure in the circuit. (See Figure 6.33.)

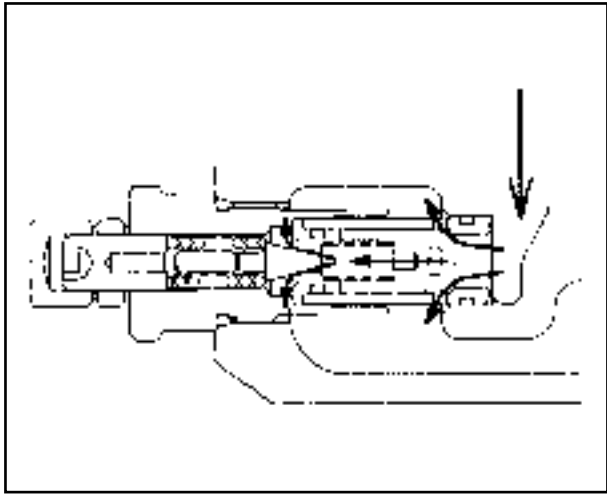

Fig. 6.33 Main Relief Valve (open)

(6) Operation of PF relief valve

The PF relief valve is a direct-acting type. The main poppet is closely seated to the valve body by the spring.

If the PF flow pressure is higher than the pressure setting of the relief valve, main poppet opens to direct the PF flow to the tank passage. (See Figures 6.34 and 6.35.)

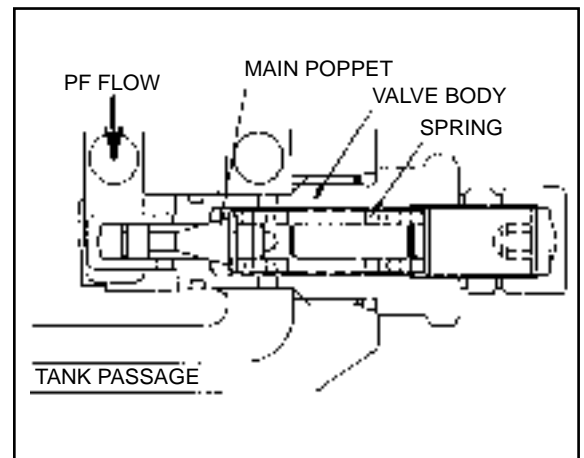

Fig. 6.34 PF Relief Valve (closed)

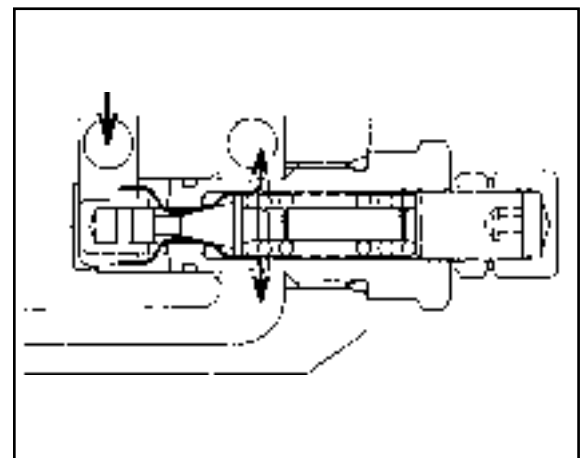

Fig. 6.35 PF Relief Valve (open)

(7) Operation of port relief valve

(a) When port relief valve is closed

If the circuit oil pressure is lower than the pressure setting, the relief valve is closed.

The oil at the port A or B flows through the orifice in the intermediate piston inside the main poppet to fill the spring chamber. The oil in the spring chamber acts on the pilot poppet, which is however forced against the seat by spring pressure to block oil flow to the tank passage. The main poppet is closely seated to the sleeve by both the spring force and the difference in area on which the oil pressure acts, to block the oil passage to the tank port. Therefore, all the oil sent into the circuit flows to the operating area. (See Figure 6.36)

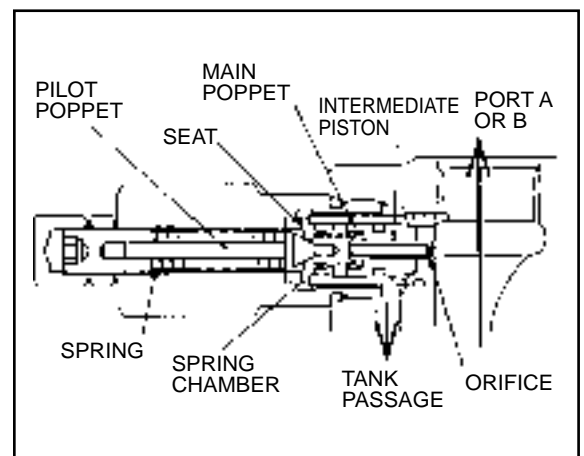

Fig. 6.36 Port Relief Valve (closed)

(b) When port relief valve opens

If the circuit oil pressure becomes higher than the relief valve pressure setting, the pressure pushes up the pilot poppet to flow into the tank passage. This causes a pressure differential across the orifice in the intermediate piston so that intermediate piston is forced against the front end of the pilot poppet. As a result, the oil pressure in the spring chamber drops to cause a pressure differential across the main poppet. This opens the main poppet and thus the passage to the tank port is also opened to allow the pressure oil to flow into the tank. (See Figure 6.37.)

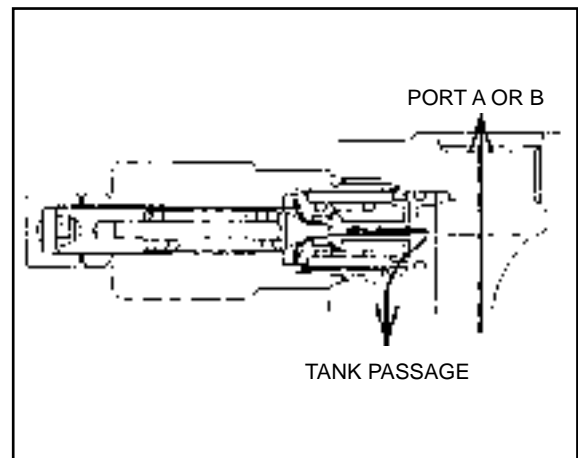

Fig. 6.37 Port Relief Valve (open)

(c) Anticavitation

If the oil pressure at the port A or B is lower than the oil pressure in the tank passage, a force occurs in the direction that opens the main poppet because of the difference in area across the main poppet. This force opens the main poppet to direct the oil from the tank passage into the port A or B, thus preventing the actuator pressure from going negative. (See Figure 6.37.)

6.1.3 VALVE CONTROLS

The control valve plungers are actuated with the levers as shown in Fig. 6.38, with each lever mounted on a single shaft.

The shafts are supported by brackets which are attached to the front guard. The movement of each lever is transmitted through a rod to the respective plungers.

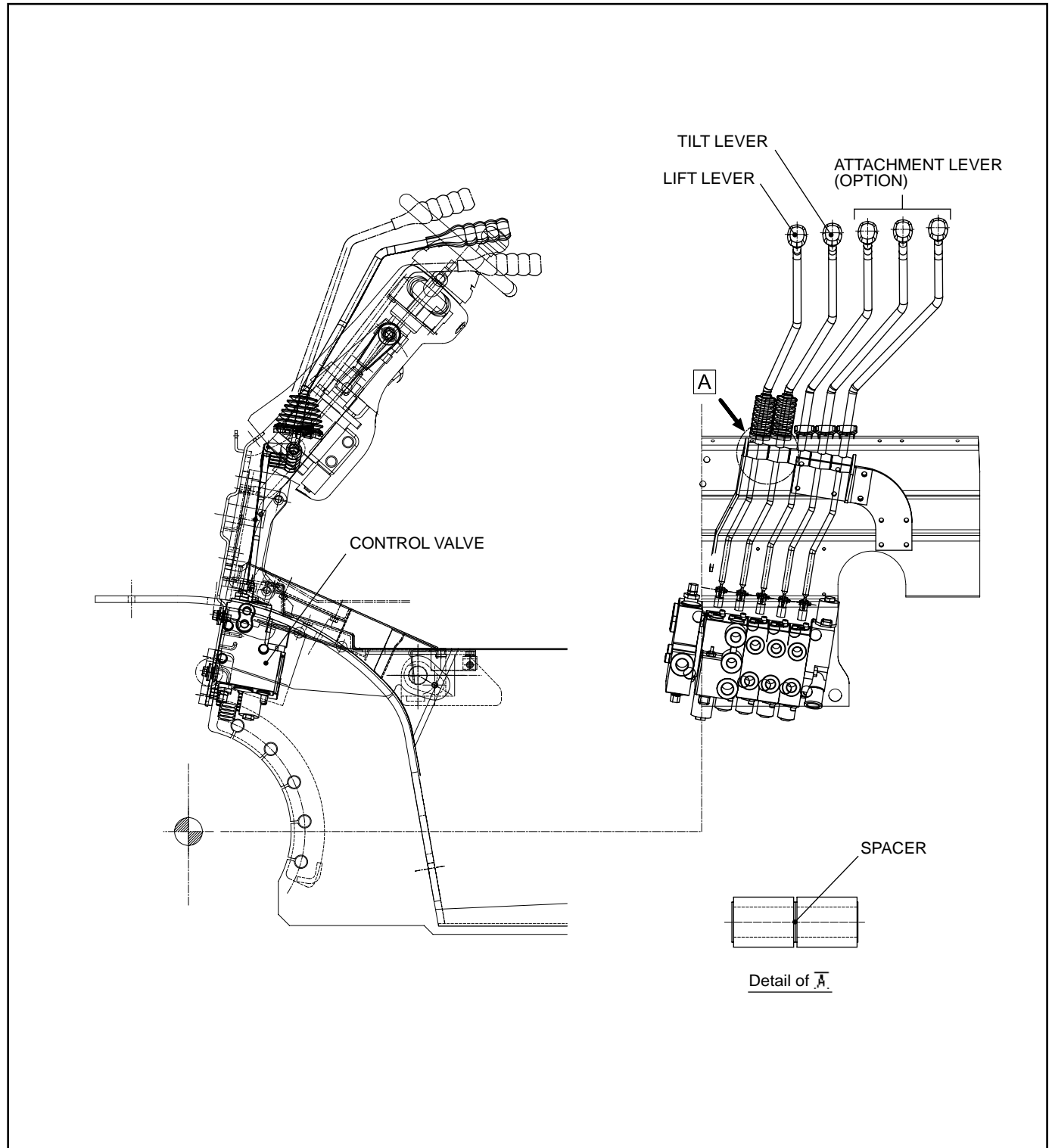

Fig. 6.38 Valve Controls (Ref.)

6.1.4 LIFT CYLINDER

The lift cylinder is a single-acting piston type consisting of a cylinder, a piston rod, a piston and a holder.

The piston is secured to the piston rod with a snap ring, with a wear ring and packing on its outer diameter.

At the bottom of one cylinder is a cut-off valve which will act as a safety device if the high-pressure hose connecting the right and left lift cylinders bursts for any reason.

The holder has a bushing and an oil seal pressed to support the piston rod and provide dust proofness for the cylinder.

■ Cut-off valve operation

When the oil in the cylinder returns into the oil tank, it passes through the holes **A** and **B** in the piston.

If the flow rate of the oil passing through those holes is less than the setting of the flow regulator valve, the pressure differential across the piston is smaller than the spring force so that the piston won't move.

If its flow rate becomes greater than the flow regulator valve pressure setting due to a burst of the high-pressure hose or for any other reason, the pressure differential across the piston becomes greater than the spring force to move the piston to the right, so that the piston comes in close contact with the area **C** on the case. This prevents the oil from flowing out of the cylinder, to stop the lowering of the forks.

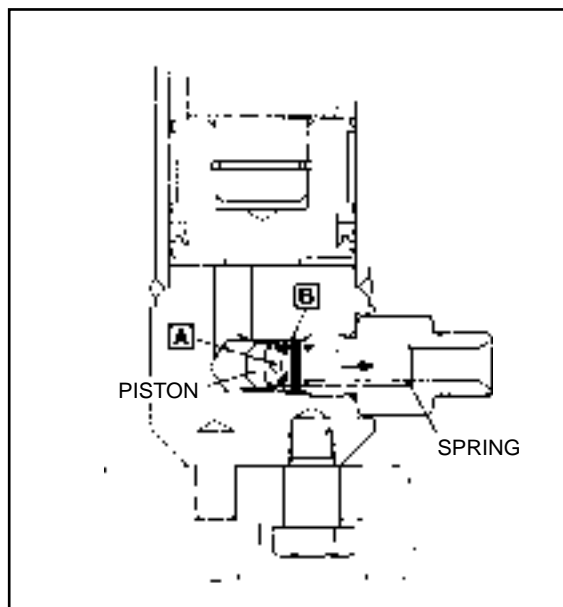

Fig. 6.39 Flow Rate Smaller than Setting

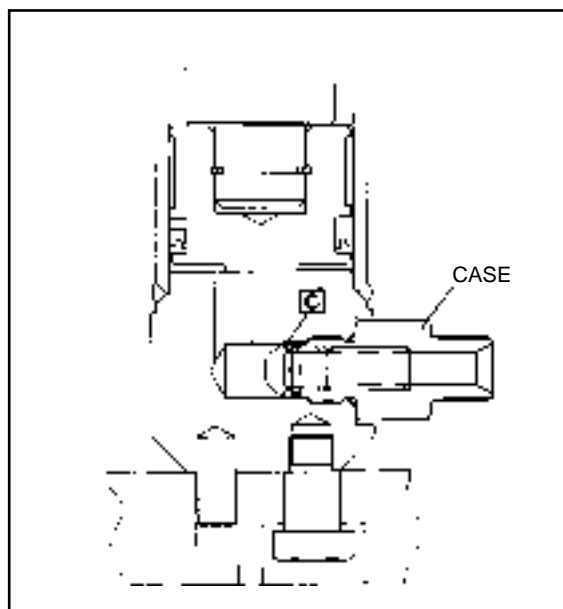

Fig. 6.40 Flow Rate Greater than Setting

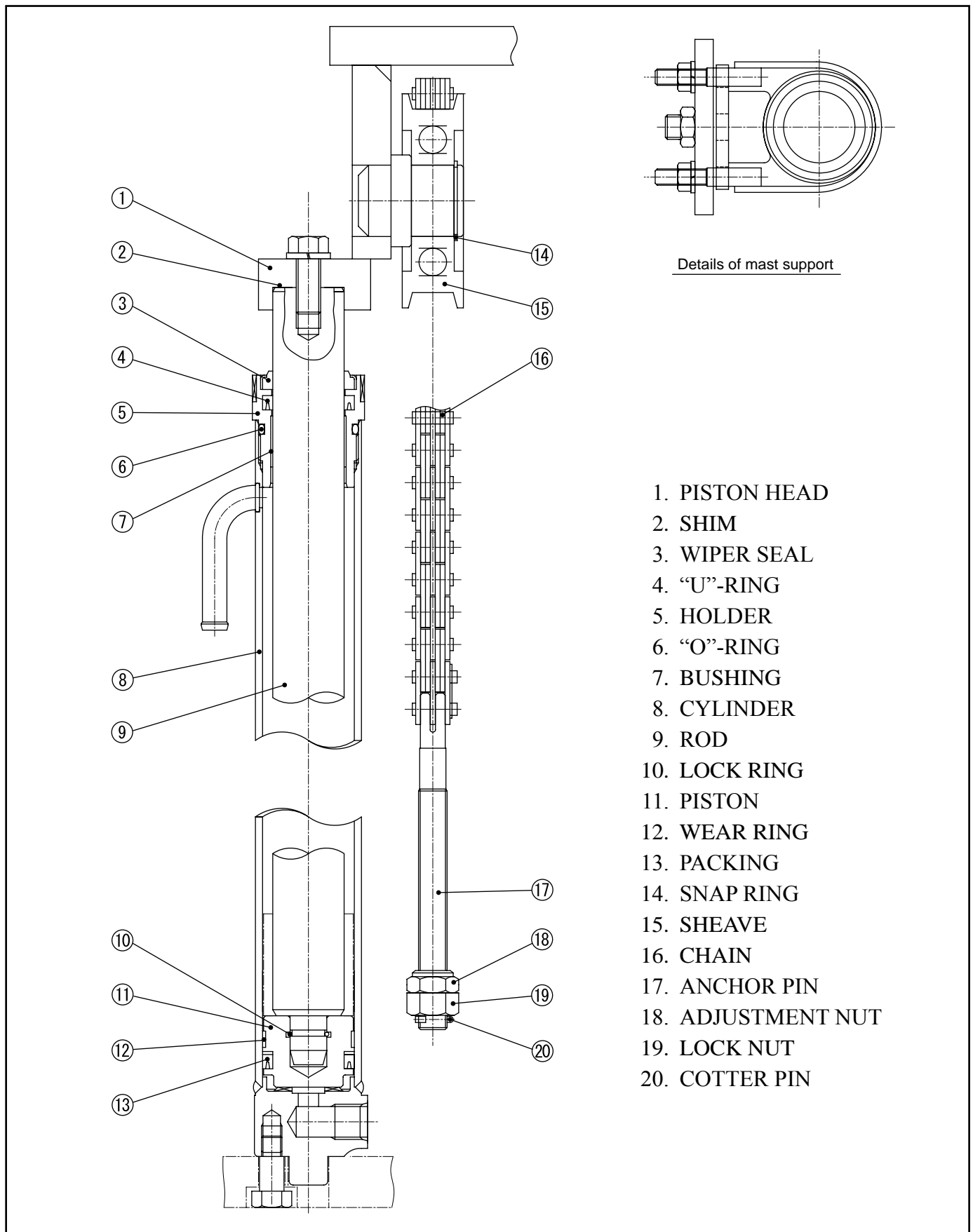
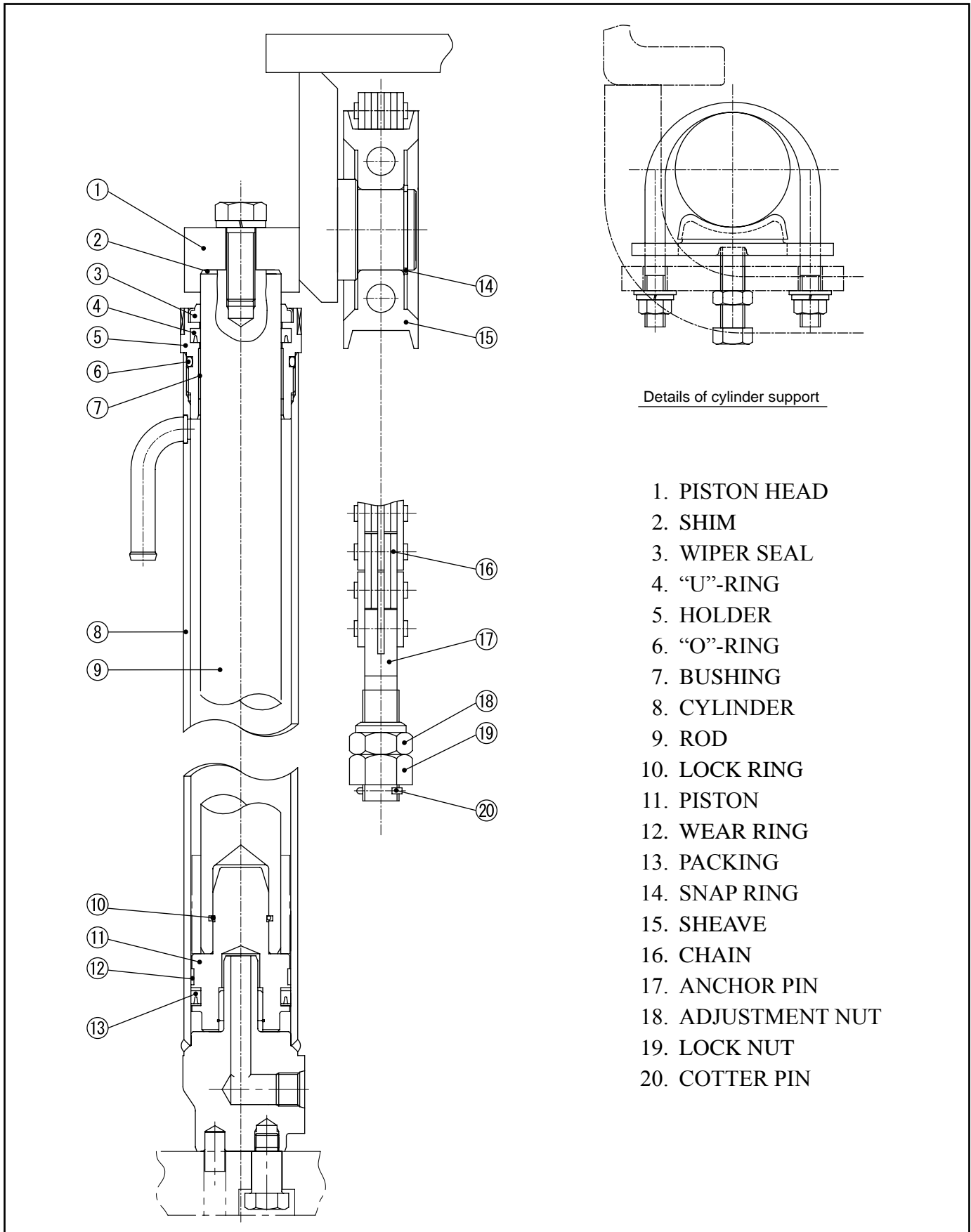

Fig. 6.41 Lift Cylinder (VM-0A7)



Details of cylinder support

- 1. PISTON HEAD
- 2. SHIM
- 3. WIPER SEAL
- 4. "U"-RING
- 5. HOLDER
- 6. "O"-RING
- 7. BUSHING
- 8. CYLINDER
- 9. ROD
- 10. LOCK RING
- 11. PISTON
- 12. WEAR RING
- 13. PACKING
- 14. SNAP RING
- 15. SHEAVE
- 16. CHAIN
- 17. ANCHOR PIN
- 18. ADJUSTMENT NUT
- 19. LOCK NUT
- 20. COTTER PIN

Fig. 6.42 Lift Cylinder (VM-2N5)

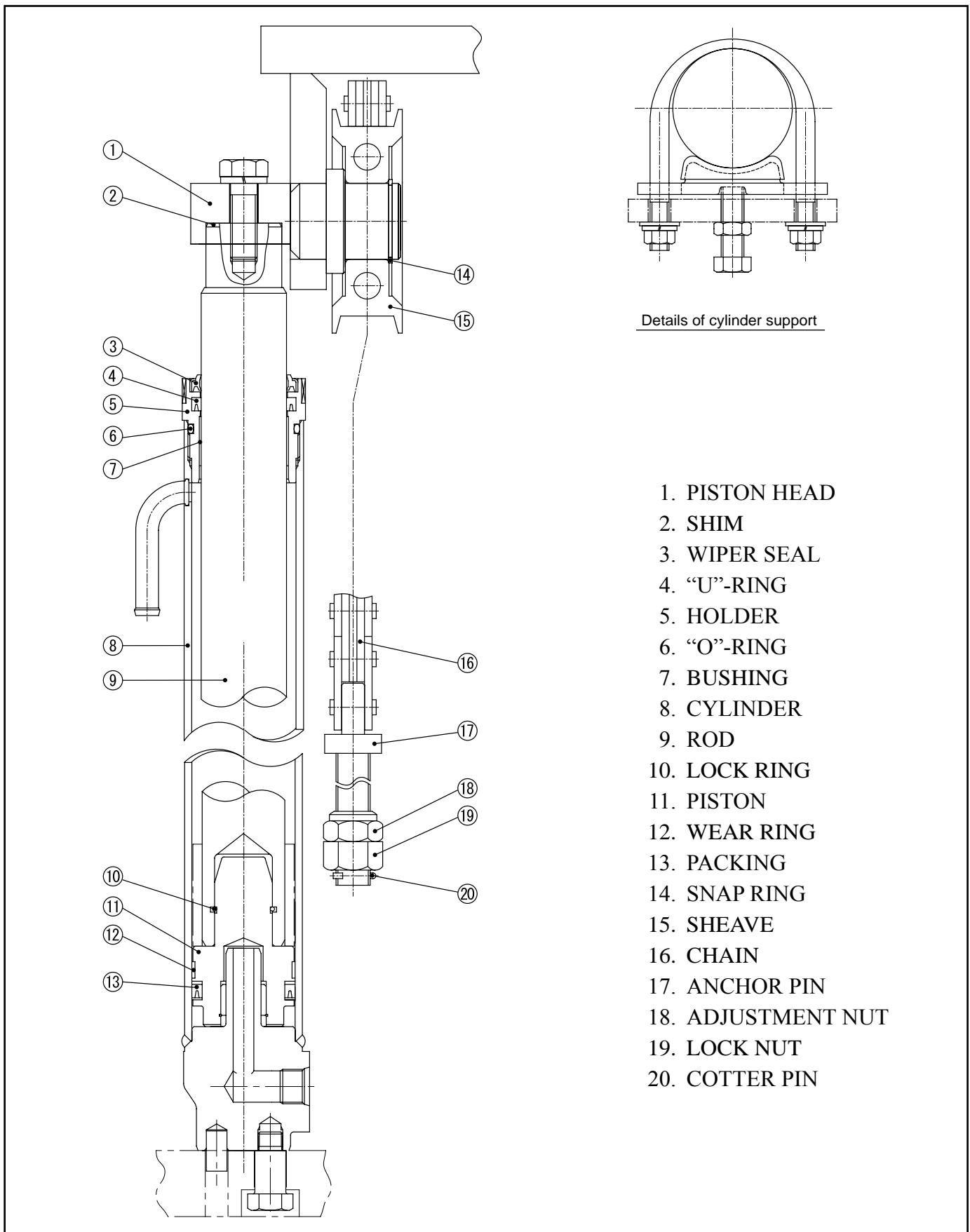

Details of cylinder support

1. PISTON HEAD
2. SHIM
3. WIPER SEAL
4. "U"-RING
5. HOLDER
6. "O"-RING
7. BUSHING
8. CYLINDER
9. ROD
10. LOCK RING
11. PISTON
12. WEAR RING
13. PACKING
14. SNAP RING
15. SHEAVE
16. CHAIN
17. ANCHOR PIN
18. ADJUSTMENT NUT
19. LOCK NUT
20. COTTER PIN

Fig. 6.43 Lift Cylinder (VM-2N9)

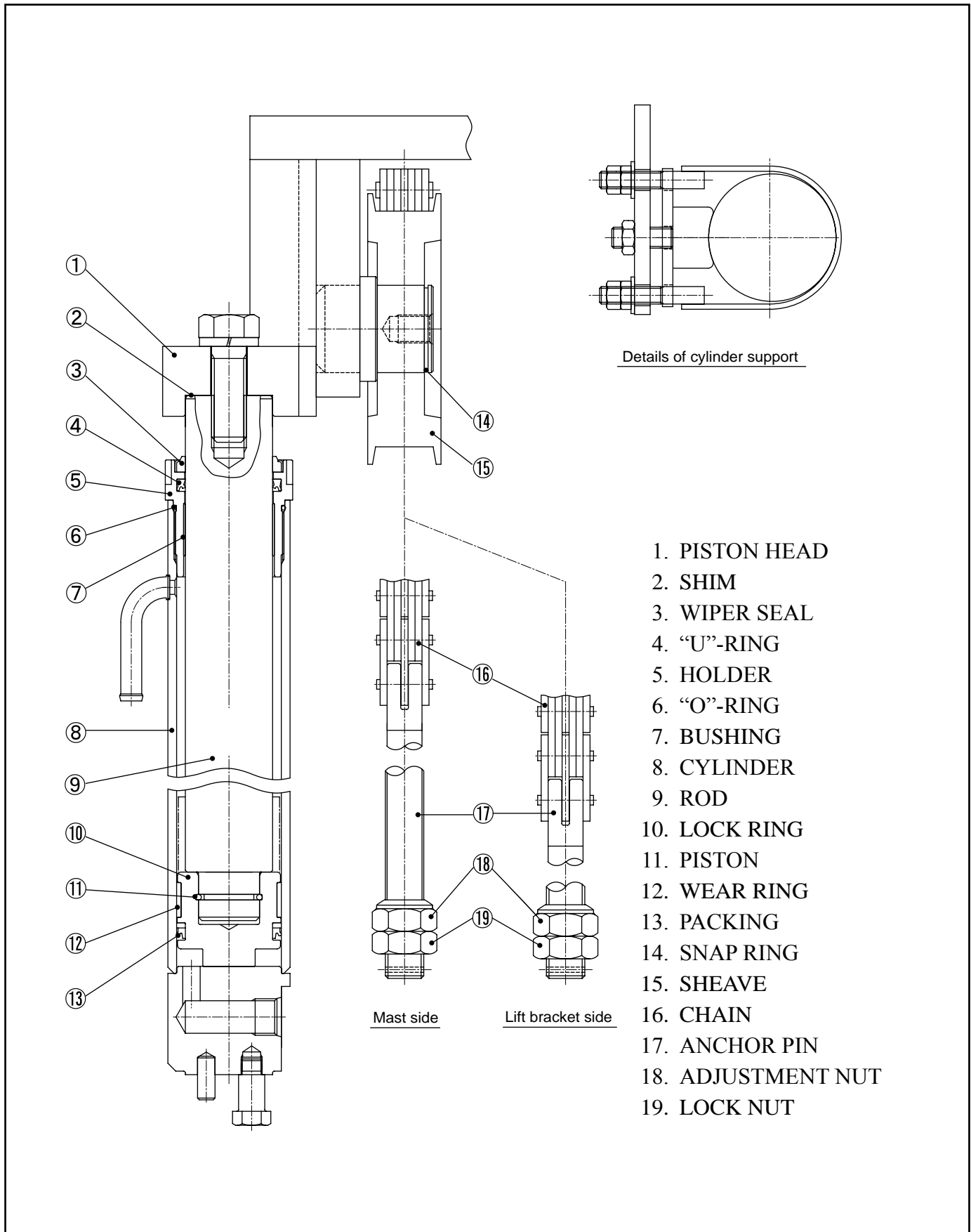

- 1. PISTON HEAD
- 2. SHIM
- 3. WIPER SEAL
- 4. "U"-RING
- 5. HOLDER
- 6. "O"-RING
- 7. BUSHING
- 8. CYLINDER
- 9. ROD
- 10. LOCK RING
- 11. PISTON
- 12. WEAR RING
- 13. PACKING
- 14. SNAP RING
- 15. SHEAVE
- 16. CHAIN
- 17. ANCHOR PIN
- 18. ADJUSTMENT NUT
- 19. LOCK NUT

Fig. 6.44 Lift Cylinder (VM-2Y5)

6.1.5 FLOW REGULATOR VALVE

The flow regulator valve controls the fork descending speed and acts as a safety device if the high-pressure hose bursts for any reason. It is located as shown in Fig.6.44.

■ Flow regulator valve operation

The oil returning from the lift cylinders enters the chamber **G**, passing through chambers **F**, **E**, **D**, **C**, **B**, and **A**, back to the control valve.

The more the oil flows through the hole **C** in the piston, the greater the pressure differential across the piston becomes to move the piston to the right.

For this reason, the hole **D** is narrowed by the hole **C** so that the oil flow is restricted to slow the fork descending speed.

When the forks are raised, the high-pressure oil from the control valve flows, passing through **A**, **B**, **C**, **D**, **E**, **F** and **G**, into the lift cylinders.

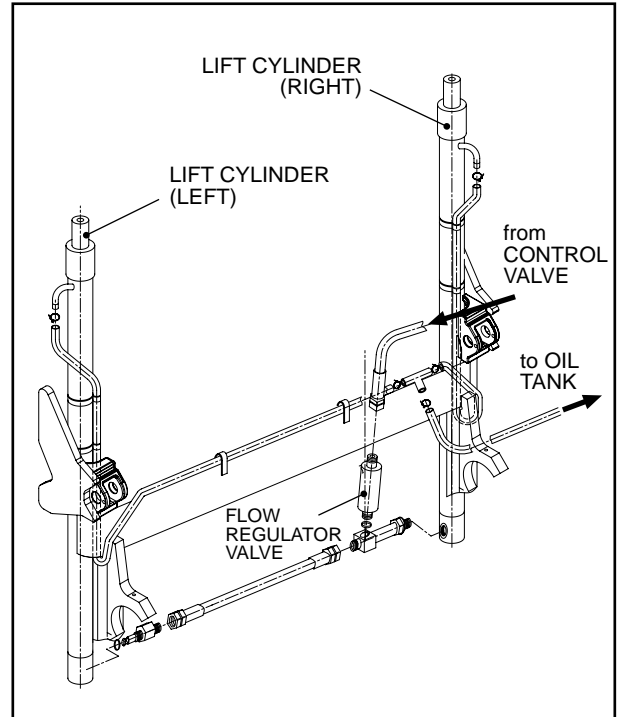

Fig. 6.44

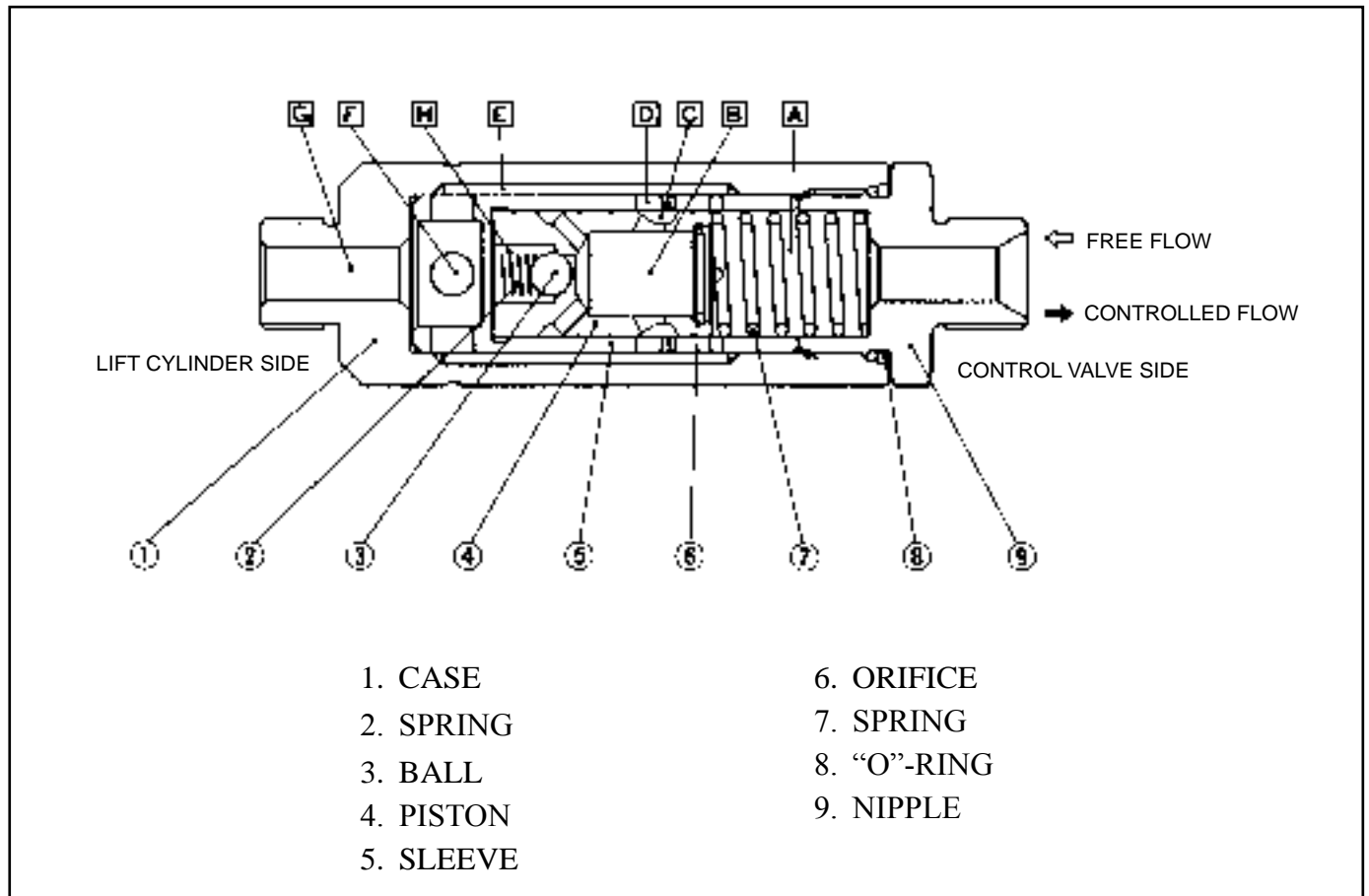

Fig. 6.45 Flow Regulator Valve

6.1.6 TILT CYLINDER

The tilt cylinder is a double-acting type, and its piston rod end is supported by the mast and the cylinder tail is connected to the frame with a pin. This truck is provided with two tilt cylinders on both sides of the front of the truck.

The tilt cylinder assembly consists primary of a cylinder body, a cylinder cap, a piston and a piston rod. The piston, attached to the piston rod with lock nuts, has a back-up ring and an “O”-ring installed on its circumference, and moves along the inner surface of the cylinder by the force of hydraulic oil.

A bushing is press-fitted inside the cylinder cap to support the piston rod, with a packing and dust seal to provide oil tightness for the piston rod and the cylinder cap. The cylinder cap, fitted with an “O”-ring on its outer periphery, is screwed into the cylinder body.

When the tilt lever in the operator’s compartment is tilted forward, high-pressure oil enters the cylinder tail side, moving the piston forward, tilting the mast forward.

When the tilt lever is tilted backward, high-pressure oil enters the cylinder cap side and moves the piston backward, tilting the mast backward.

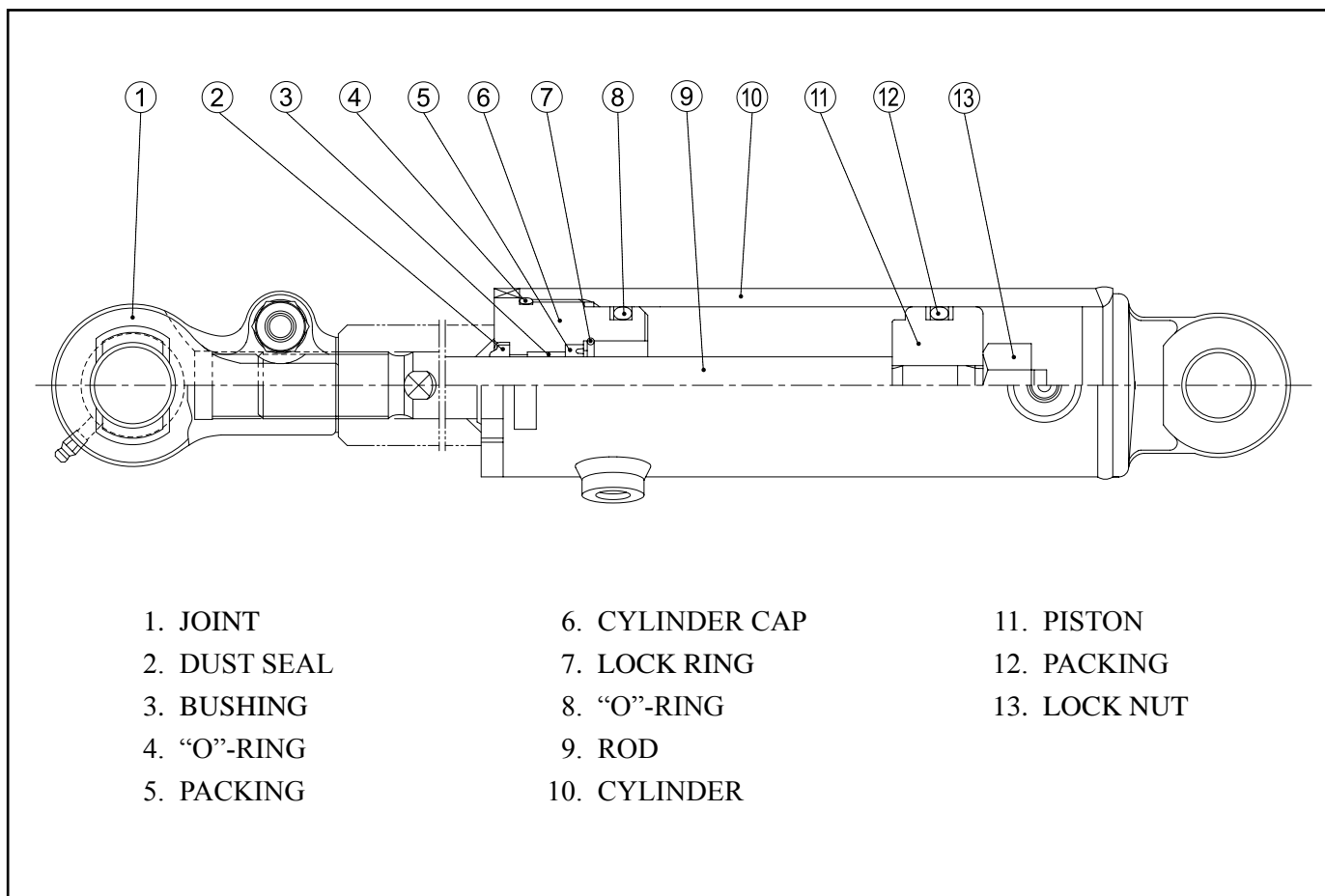

Fig. 6.46 Tilt Cylinder

6.1.7 OIL TANK

The oil tank is integral with the frame and located at the right-hand side of the truck body. Figure 6.47 shows its construction.

Inside the oil tank are a suction filter and a return filter to remove dust from the oil.

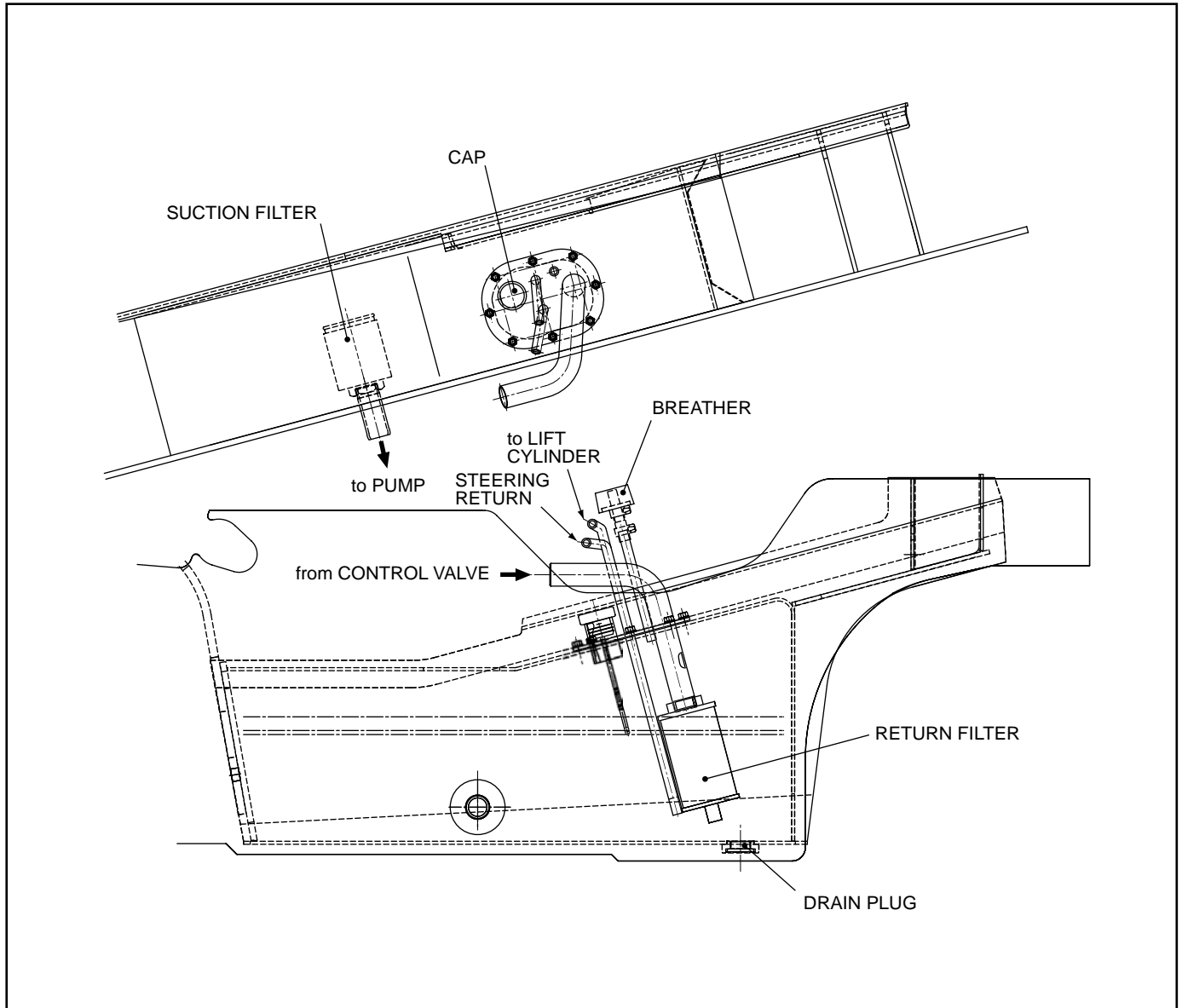

Fig. 6.47 Oil Tank

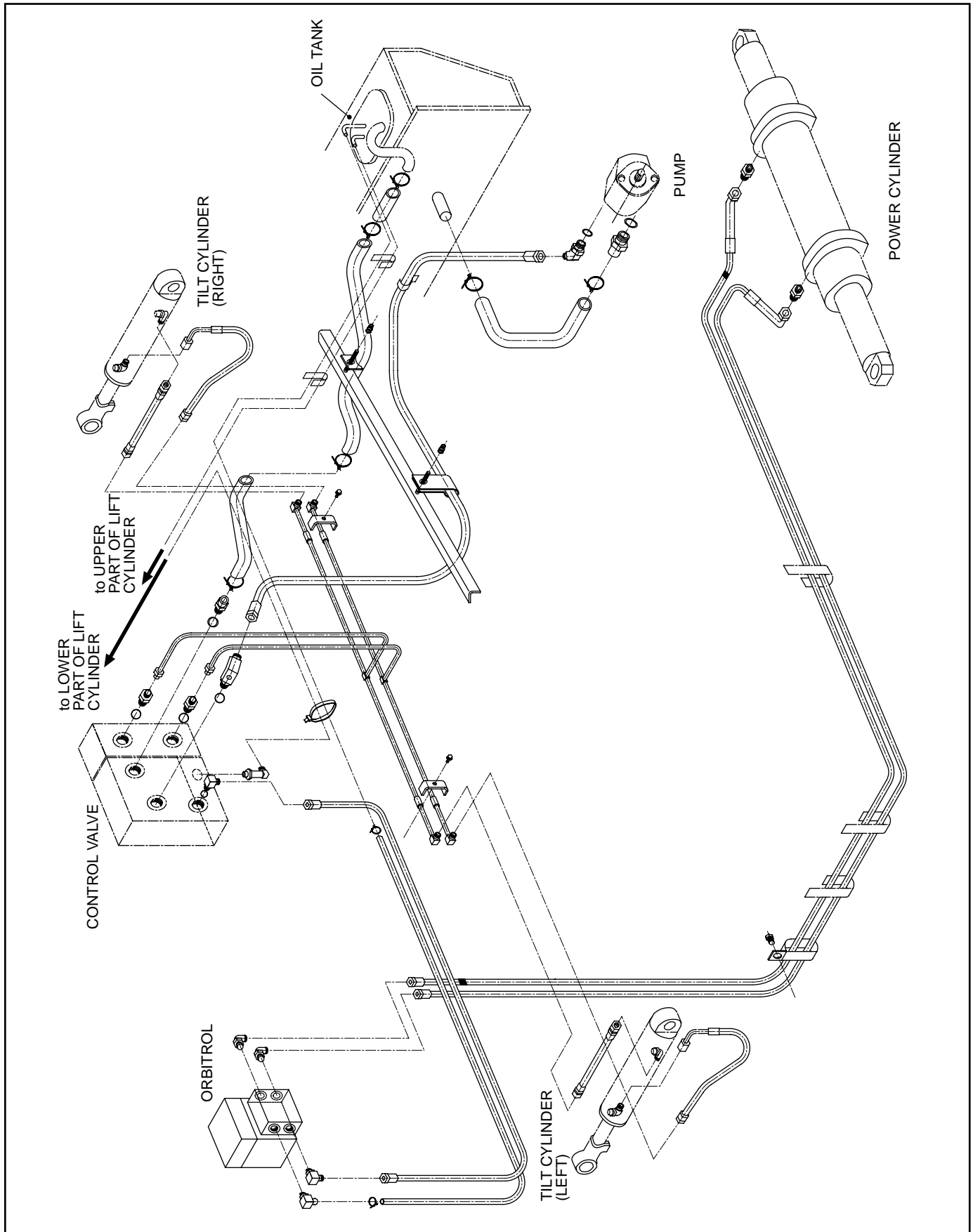

Fig. 6.48 Hydraulic Oil Piping (Trucks with capacities from 1.5 to 1.75 tons)

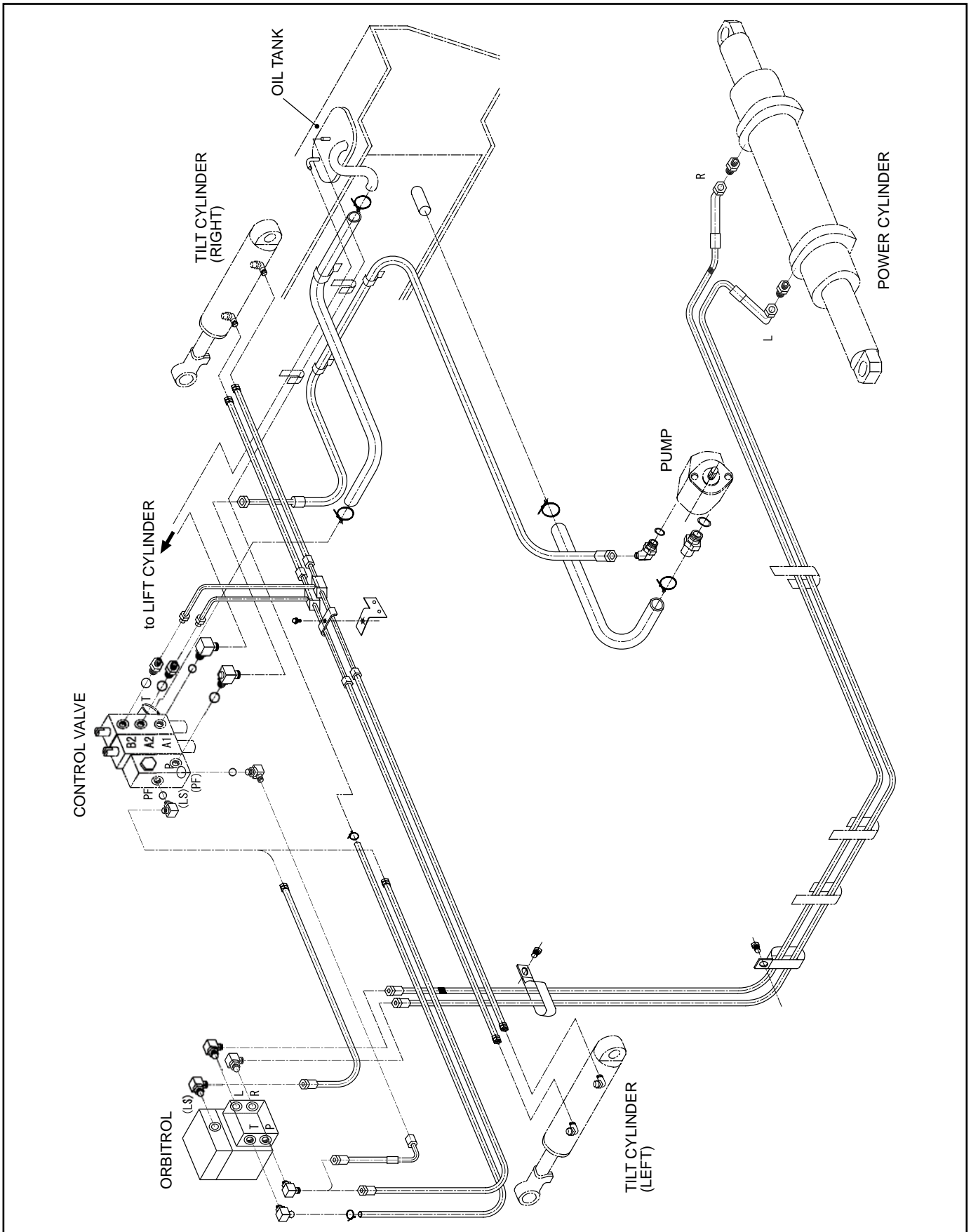



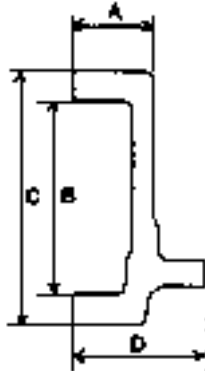
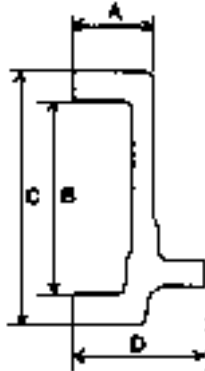
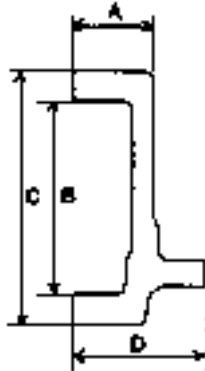

Fig. 6.49 Hydraulic Oil Piping (Engine-powered, 2.0- to 3.5-ton trucks)

NOTE

A series of horizontal dashed lines providing a space for notes.

7. LOAD HANDLING SYSTEM

Truck Model	FHG15T3 FHG18T3 FHD15T3 FHD18T3	FG20T3 FHG20T3 FG25T3 FHG25T3	FD20T3 FHD20T3A FD25T3 FHD25T3A	FG30T3 FHG30T3	FD30T3 FHD30T3A	FG35T3S FD35T3S
Item						
Name	VM-0A7	VM-2N5		VM-2N9		VM-2Y5
Type	Roller type 2-stage telescopic mast with free lift					
Standard max. lifting height	3000 mm [118.11 in.]					
Fork lifting system	Hydraulic					
Fork tilting system	Hydraulic					
Lift chain	Leaf chain BL534	Leaf chain BL634	Leaf chain BL823	Leaf chain BL823	Leaf chain BL823	Leaf chain BL834
Channel shape						
Outer channel						
Inner channel	 <p>A : 44 mm [1.73 in.] B : 102.5 mm [4.04 in.] C : 134.5 mm [5.3 in.]</p>	 <p>A : 48 mm [1.89 in.] B : 119.5 mm [4.7 in.] C : 161.5 mm [6.36 in.]</p>	 <p>A : 60 mm [2.36 in.] B : 124 mm [9.88 in.] C : 170 mm [6.69 in.]</p>			
	 <p>A : 43 mm [1.69 in.] B : 102.5 mm [4.04 in.] C : 134.5 mm [5.3 in.] D : 72 mm [2.83 in.]</p>	 <p>A : 48 mm [1.89 in.] B : 119.5 mm [4.7 in.] C : 161.5 mm [6.36 in.] D : 76 mm [2.99 in.]</p>	 <p>A : 45 mm [1.77 in.] B : 119.5 mm [4.70 in.] C : 159.5 mm [6.28 in.] D : 76 mm [2.99 in.]</p>			

7.1 GENERAL DESCRIPTION

The roller-type two-stage telescopic upright consists of an outer channel, an inner channel and a carriage.

7.1.1 OUTER AND INNER CHANNELS

The outer and inner channels are of welded construction. The outer channel has a support at its lower part, with which the upright assembly is mounted on the drive axle.

The outer channel is supported to the frame through the tilt cylinders, which extend and retract to tilt the upright forward and backward, respectively.

The end rollers are installed on the lower outside of the inner channel and upper inside of the outer channel with shims.

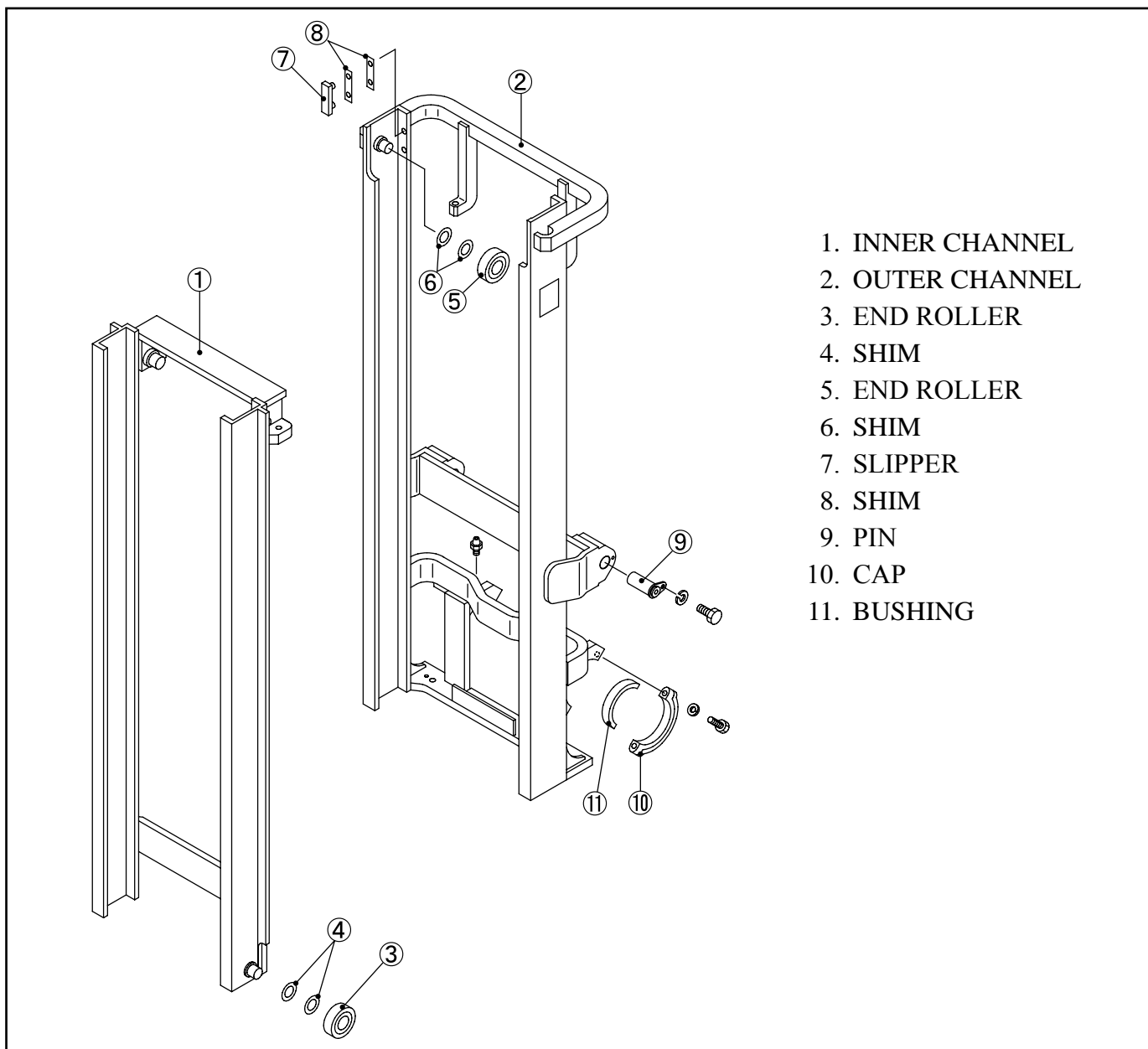

Fig. 7.1 Outer and Inner Channels (VM-0A7)

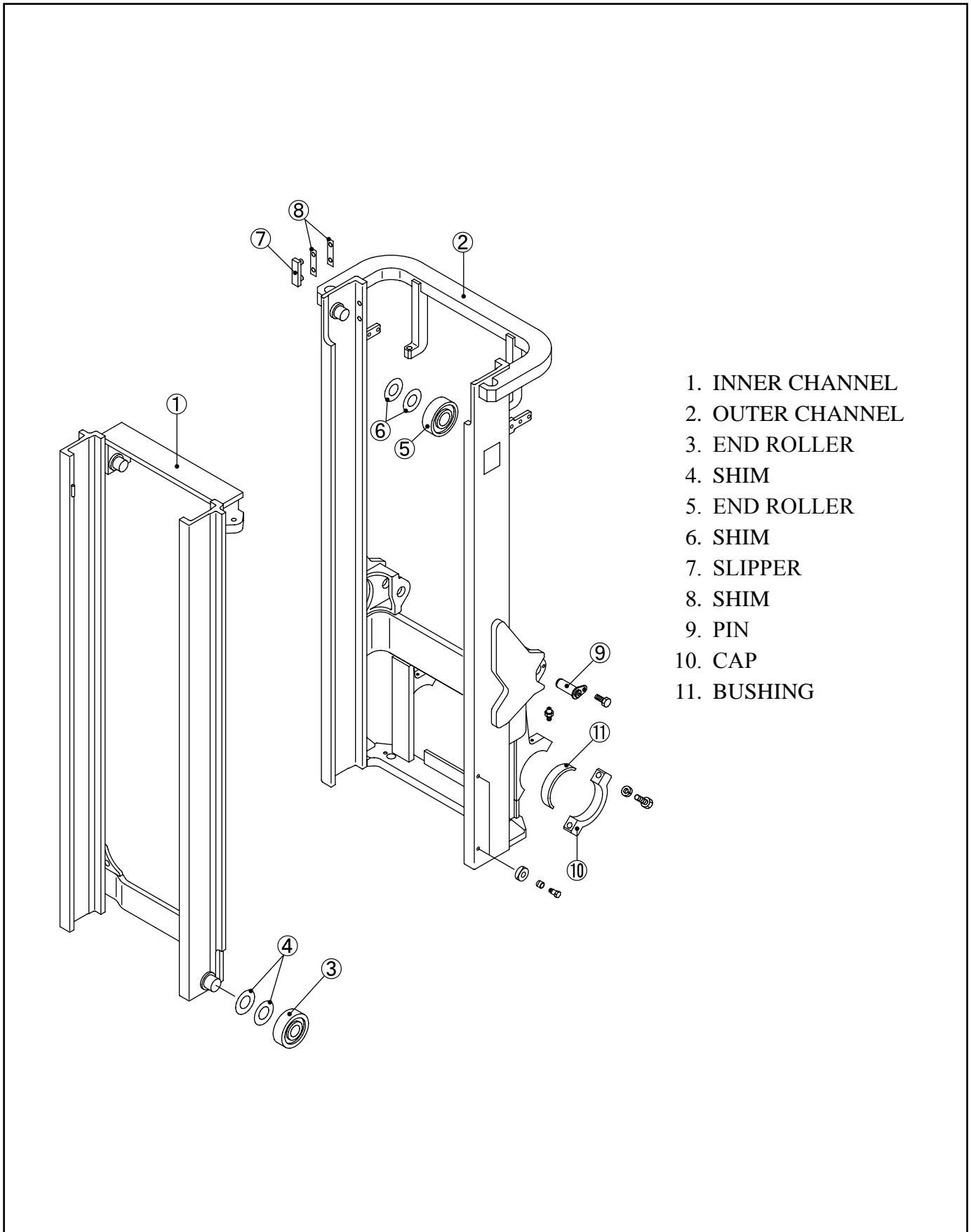

Fig. 7.2 Outer and Inner Channels (VM-2N5, VM-2N9, VM-2Y5)

7.1.2 CARRIAGE

The carriage has end rollers installed with bearings on its end roller shafts welded to the carriage. The end rollers are shim adjusted and roll along inside the inner channel assembly.

The fore-and-aft load is sustained by the end rollers and the lateral load by the side rollers provided at the lower part of the carriage. When the forks are raised to the top position, the top end rollers come out beyond the top of the upright.

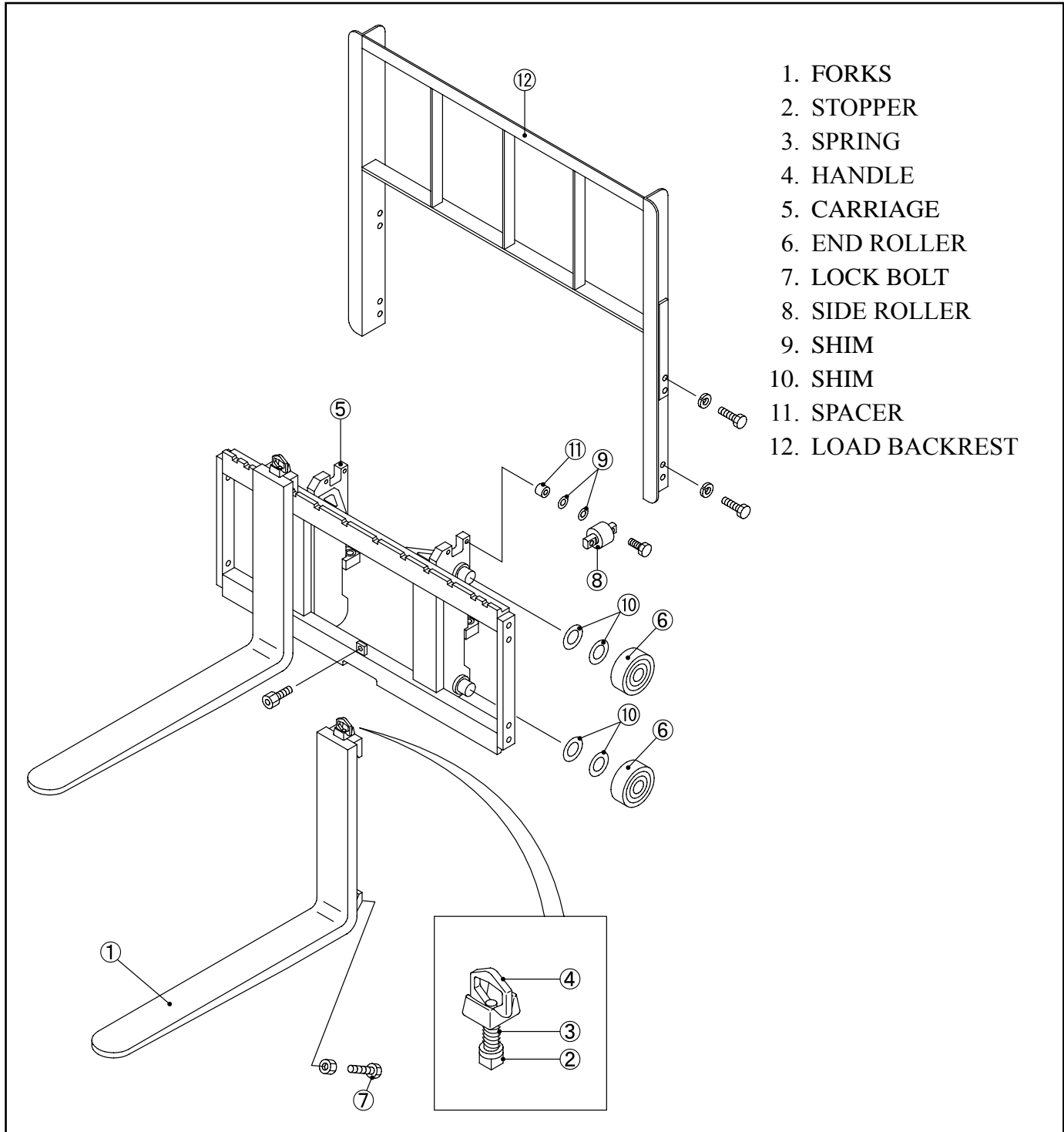
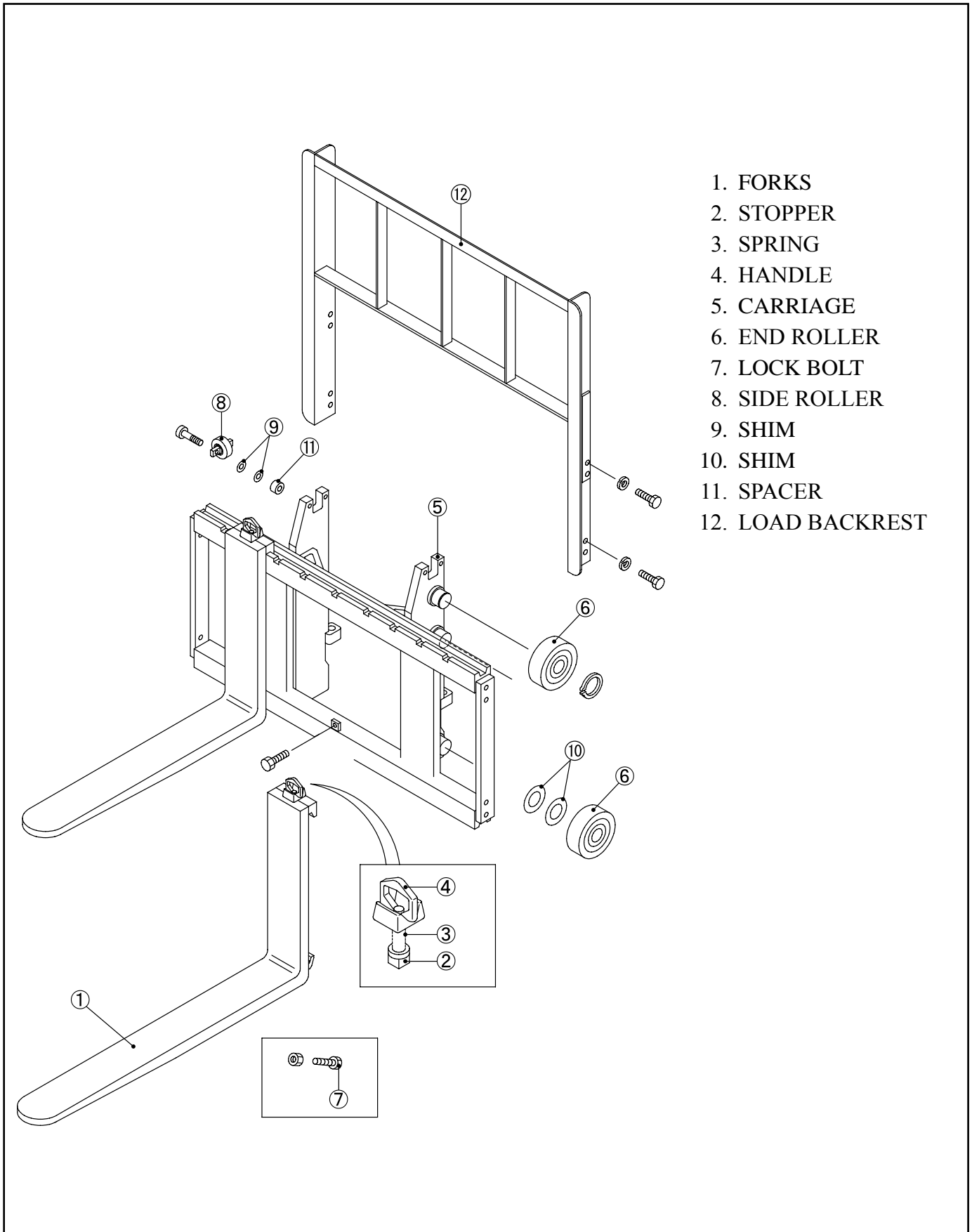

Fig. 7.3 Carriage (VM-0A7)



- 1. FORKS
- 2. STOPPER
- 3. SPRING
- 4. HANDLE
- 5. CARRIAGE
- 6. END ROLLER
- 7. LOCK BOLT
- 8. SIDE ROLLER
- 9. SHIM
- 10. SHIM
- 11. SPACER
- 12. LOAD BACKREST

Fig. 7.4 Carriage (VM-2N5, VM-2N9, VM-2Y5)

7.1.3 LOCATIONS OF ROLLERS

The end and side rollers are installed on the carriage.

The end rollers support the fore-and-aft load and the side rollers support the lateral load so that the inner channels and carriage are raised and lowered smoothly.

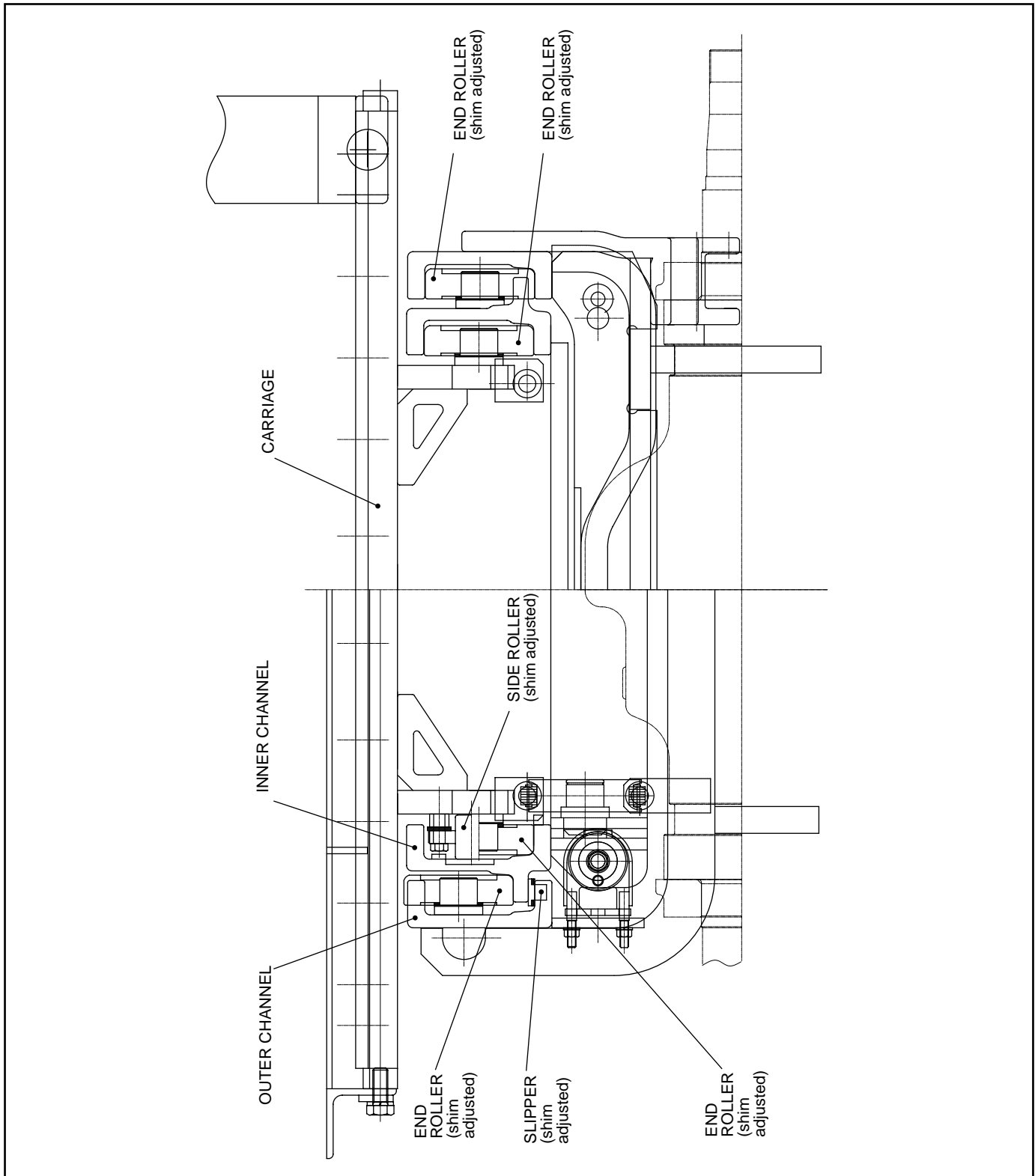

Fig. 7.5 Locations of Rollers (VM-0A7)

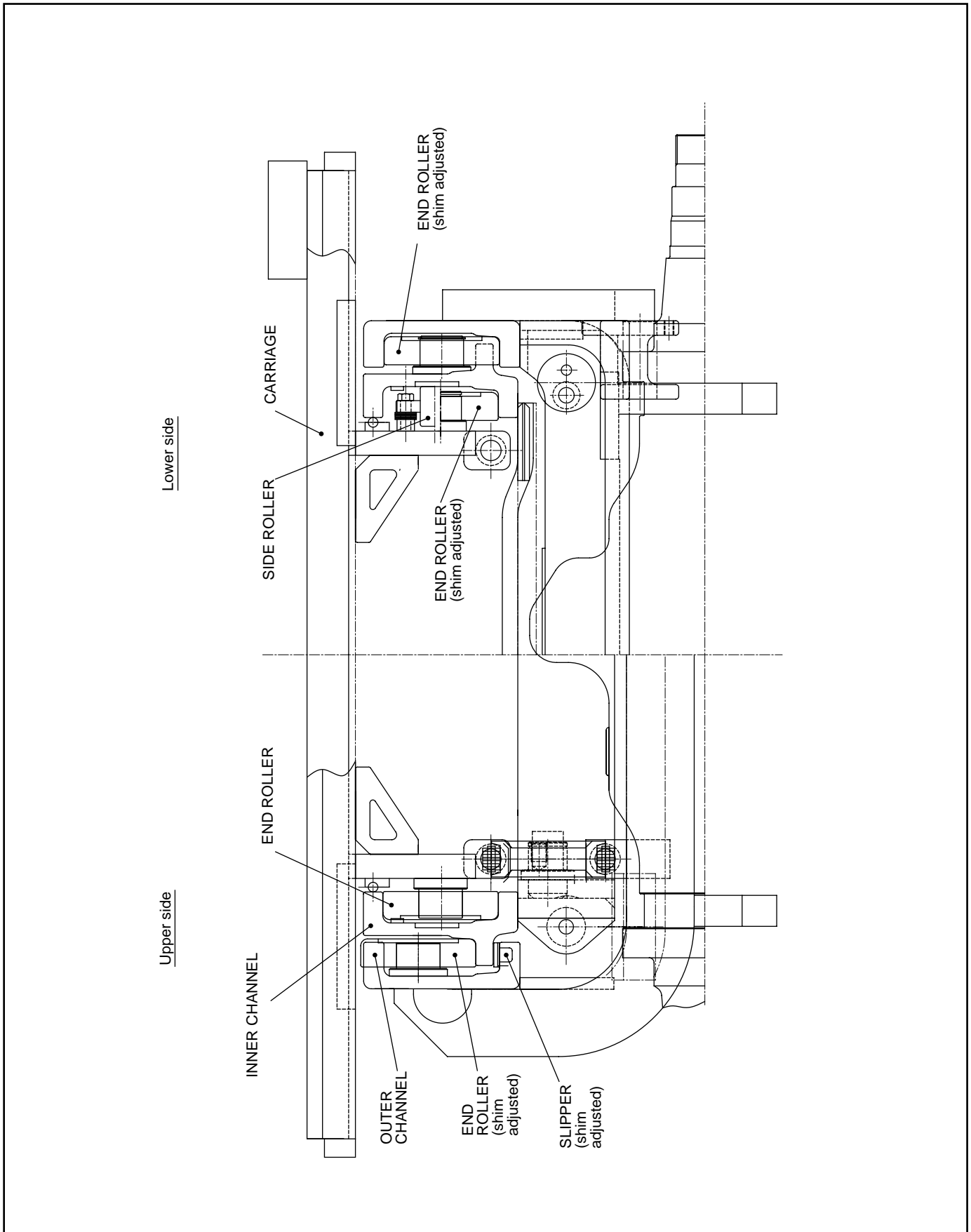

Fig. 7.6 Locations of Rollers (VM-2N5, VM-2N9)

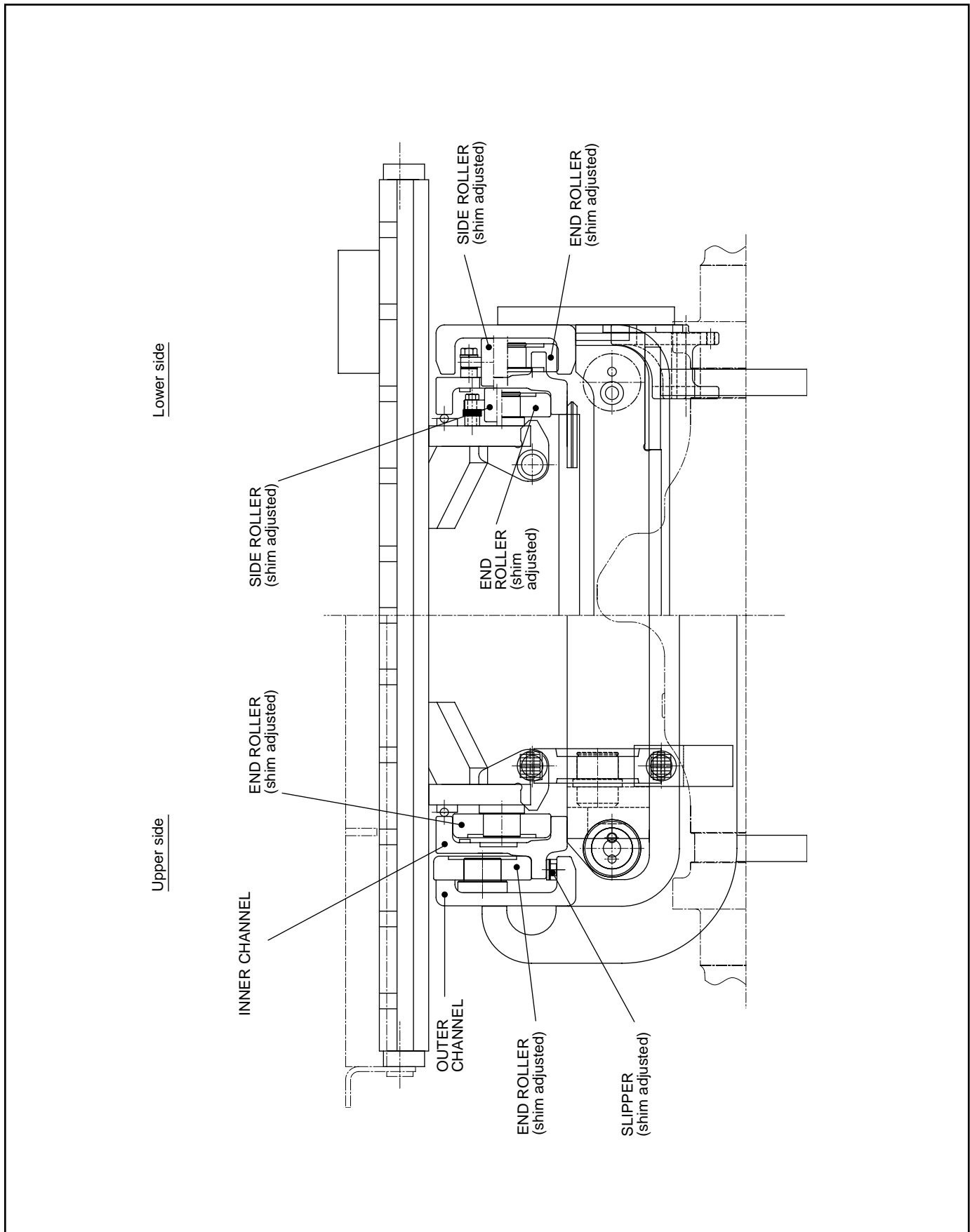

Fig. 7.7 Locations of Rollers (VM-2Y5)

8. ELECTRIC WIRING



The electric components of the truck are wired through several types of wire harnesses and color coded by circuit.

The wire harnesses are connected with connectors (2 types) or screw.

Table 8.1 Color symbols and examples

 <p>Example: Yellow coating with a blue marking</p>	B	Black	R	Red	 <p>Example: White coating without marking</p>
	G	Green	W	White	
	L	Blue	Y	Yellow	
	O	Orange	Lg	Light green	
	P	Pink	Lb	Light blue	

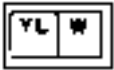
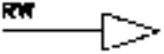
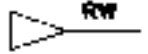
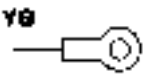
Table 8.2 Connector symbol

Connection type		Plug-in side	Receptacle side	Remarks
Plug-in type	Housing			The alphabetic letters means colors. (Table 8.1)
	Plug			
Screw type				

The dotted lines in the circuit diagrams are given for optional equipment.

⚠ DANGER ! Use due caution when handling the battery unit.

1. Never short the circuit, spark, smoke or use fire near the battery unit. Since flammable gas is always released from the battery, there is a danger of causing an explosion.
2. The battery electrolyte is dilute sulfuric acid. It will cause burns if it gets on the skin. If electrolyte comes in contact with the skin, flush with water. It can cause blindness if it gets into eyes. If electrolyte gets into your eyes, flush your eyes out with water and get to a doctor.

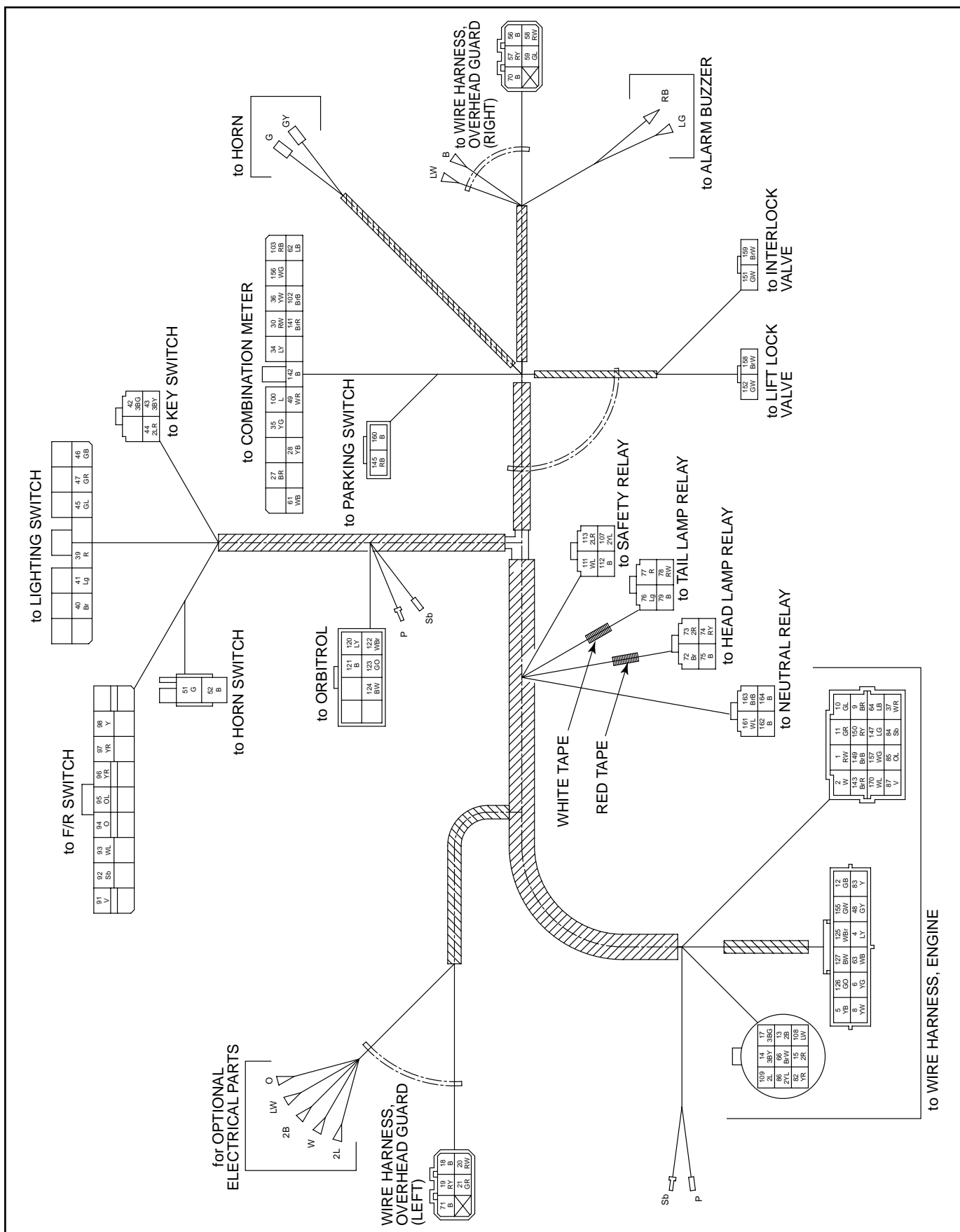

Fig. 8.1 Wire Harness, Front Guard

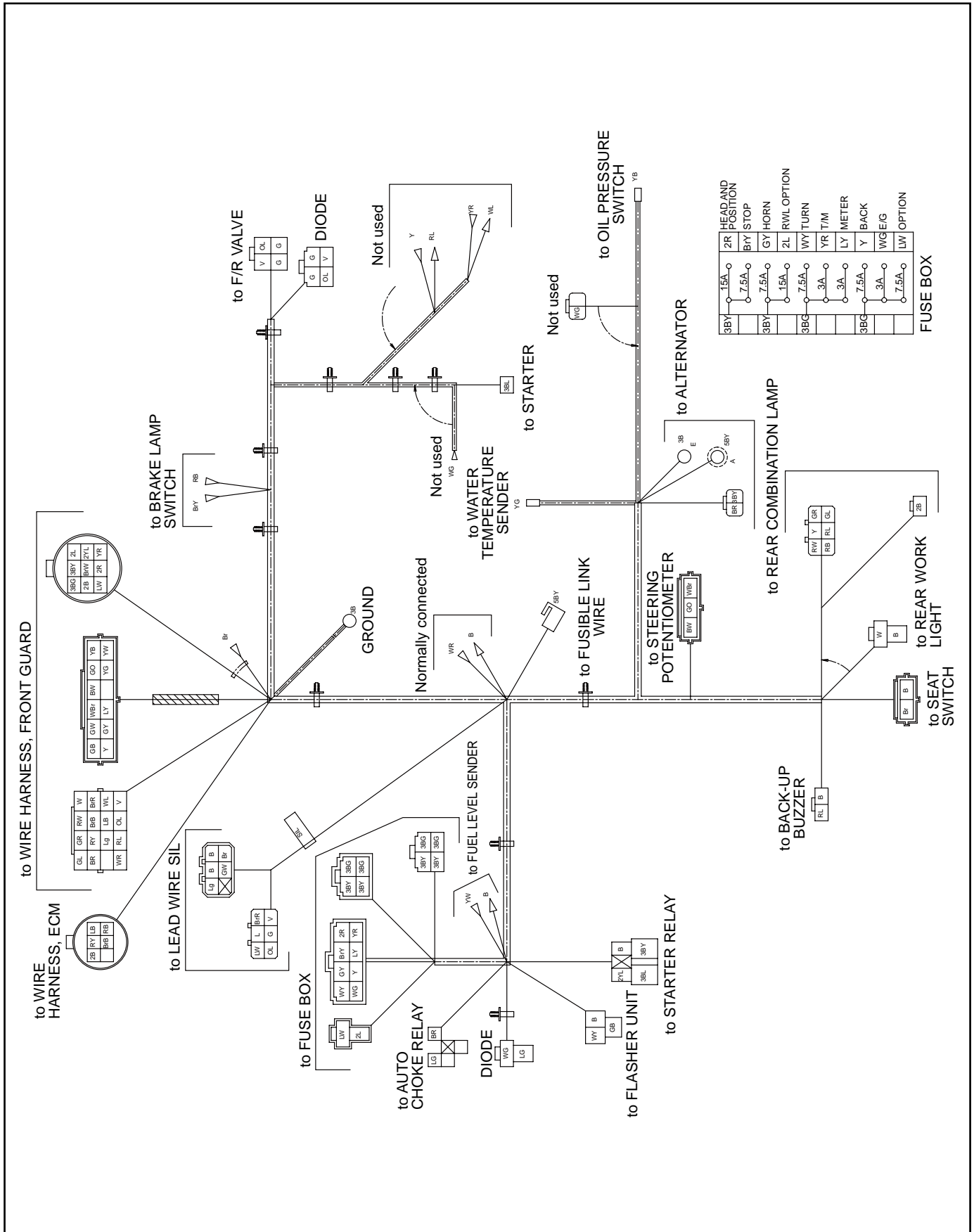

Fig. 8.2 Wire Harness, Engine (K21, K25)

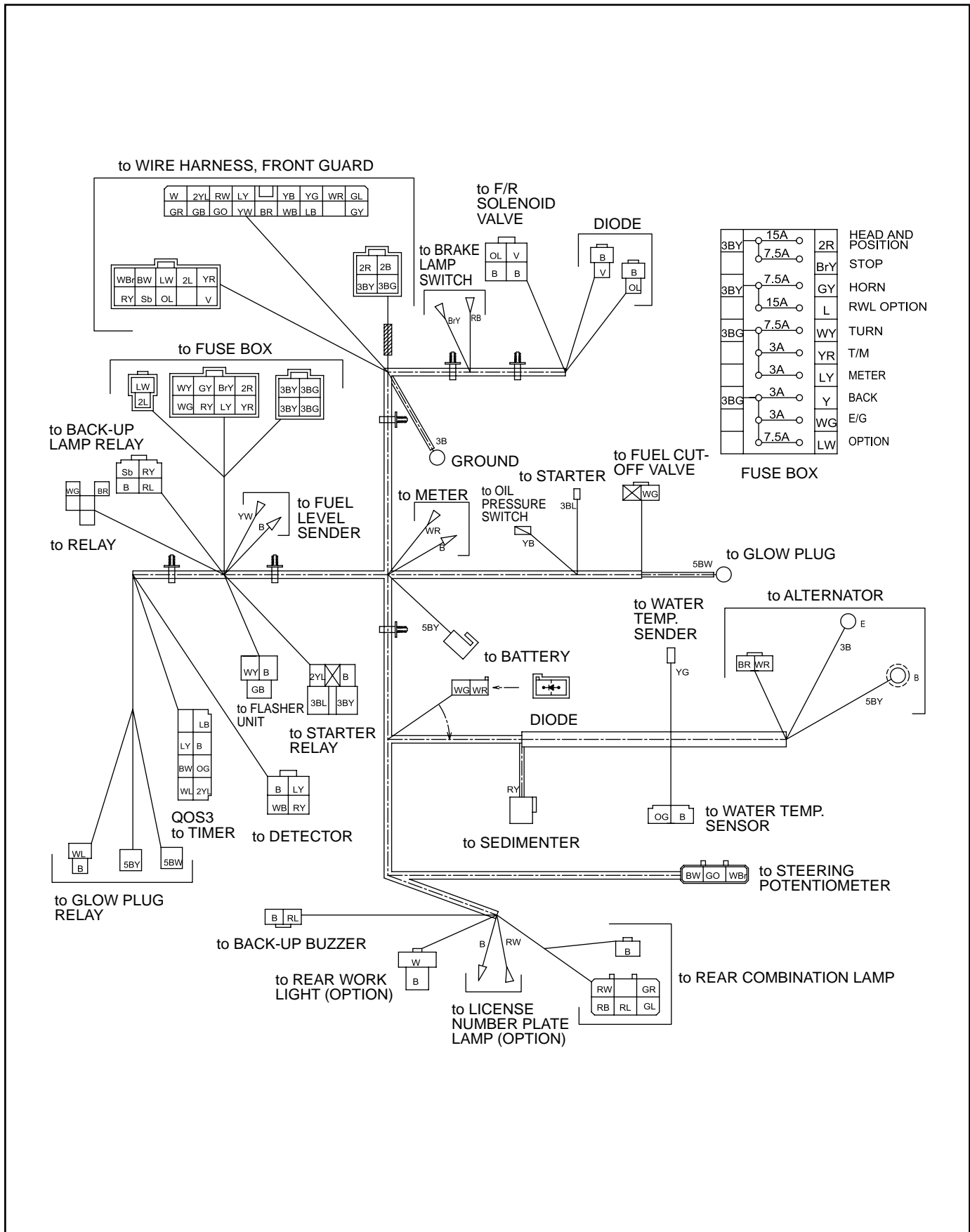

Fig.8.3 Wire Harness, Engine (Trucks with TD27, QD32)

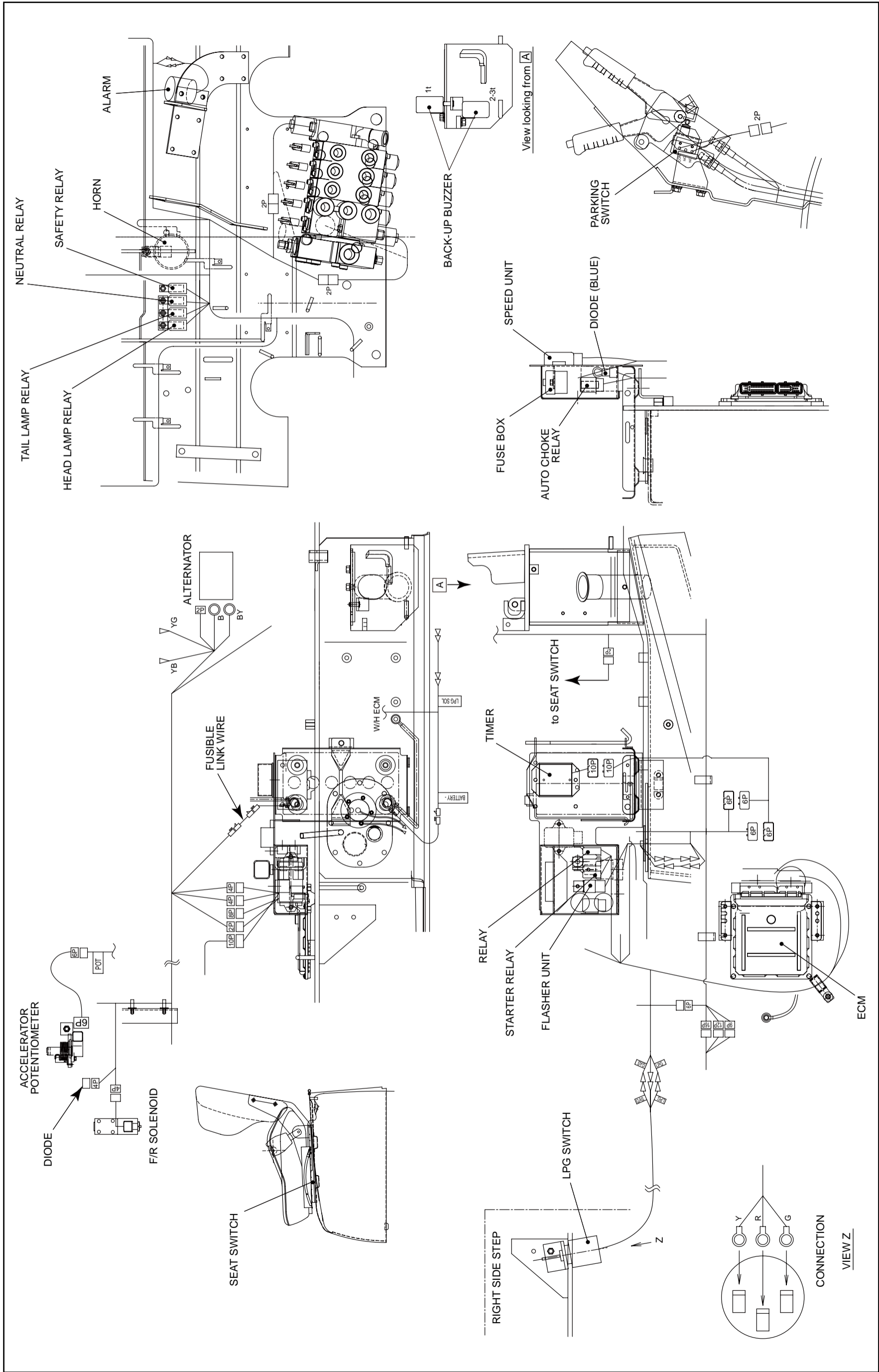

Fig. 8.4 Location of Electrical Parts (Engine powered trucks with K21 or K25)

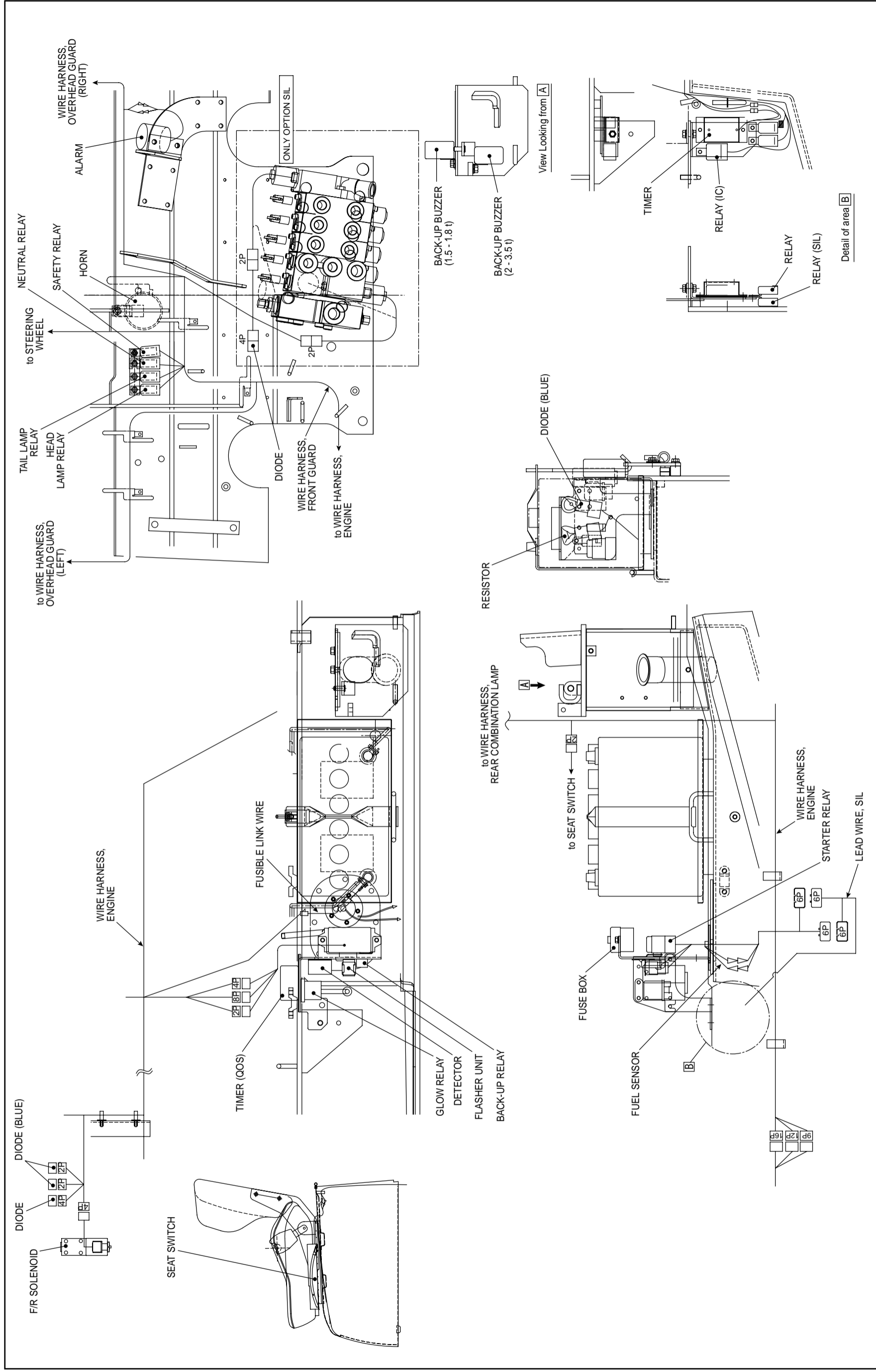

Fig. 8.5 Locations of Electrical Parts (Engine-powered trucks with T27, QD32)

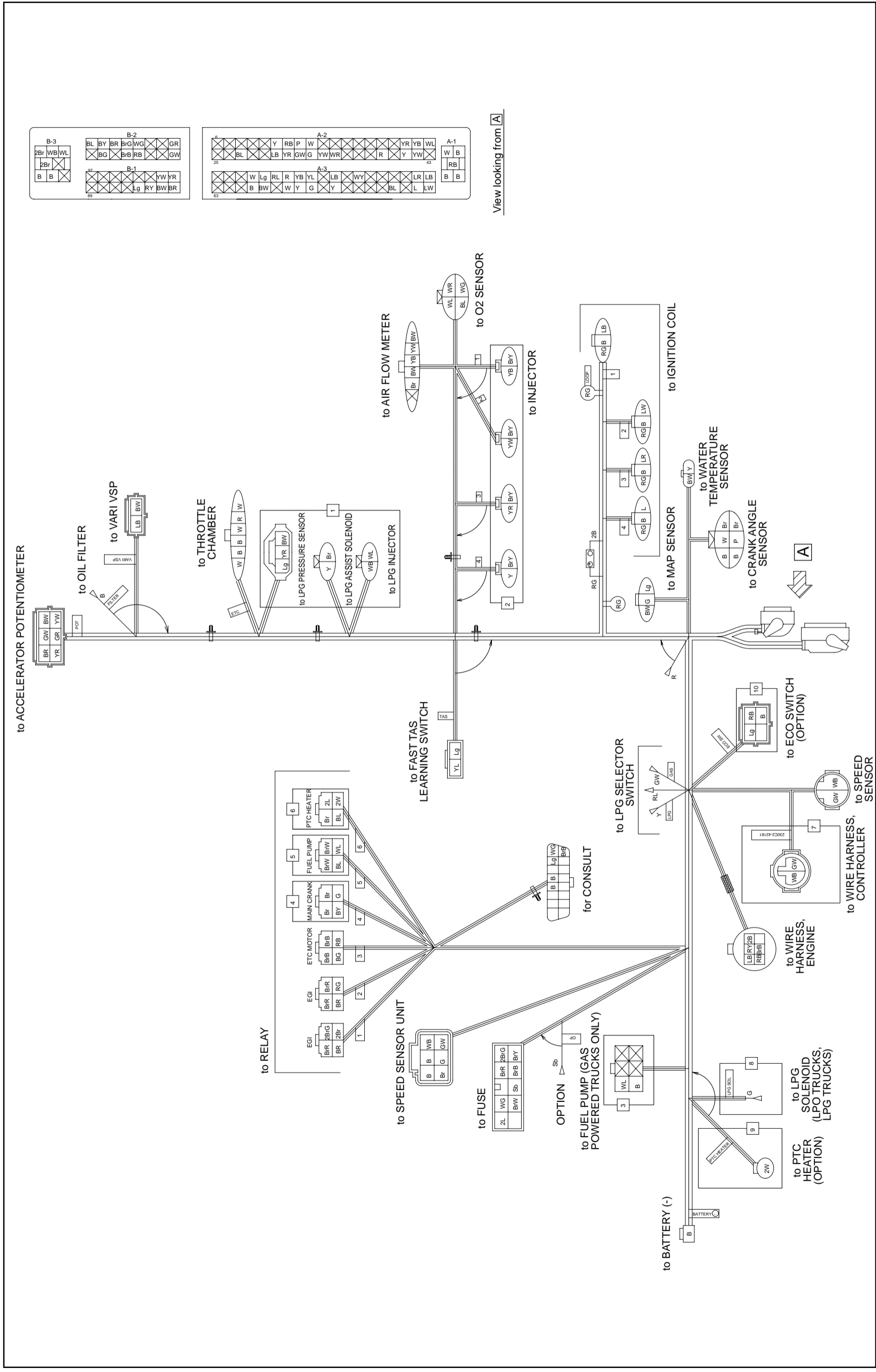

Fig. 8.6 Wire Harness, ECM (K21, K25)

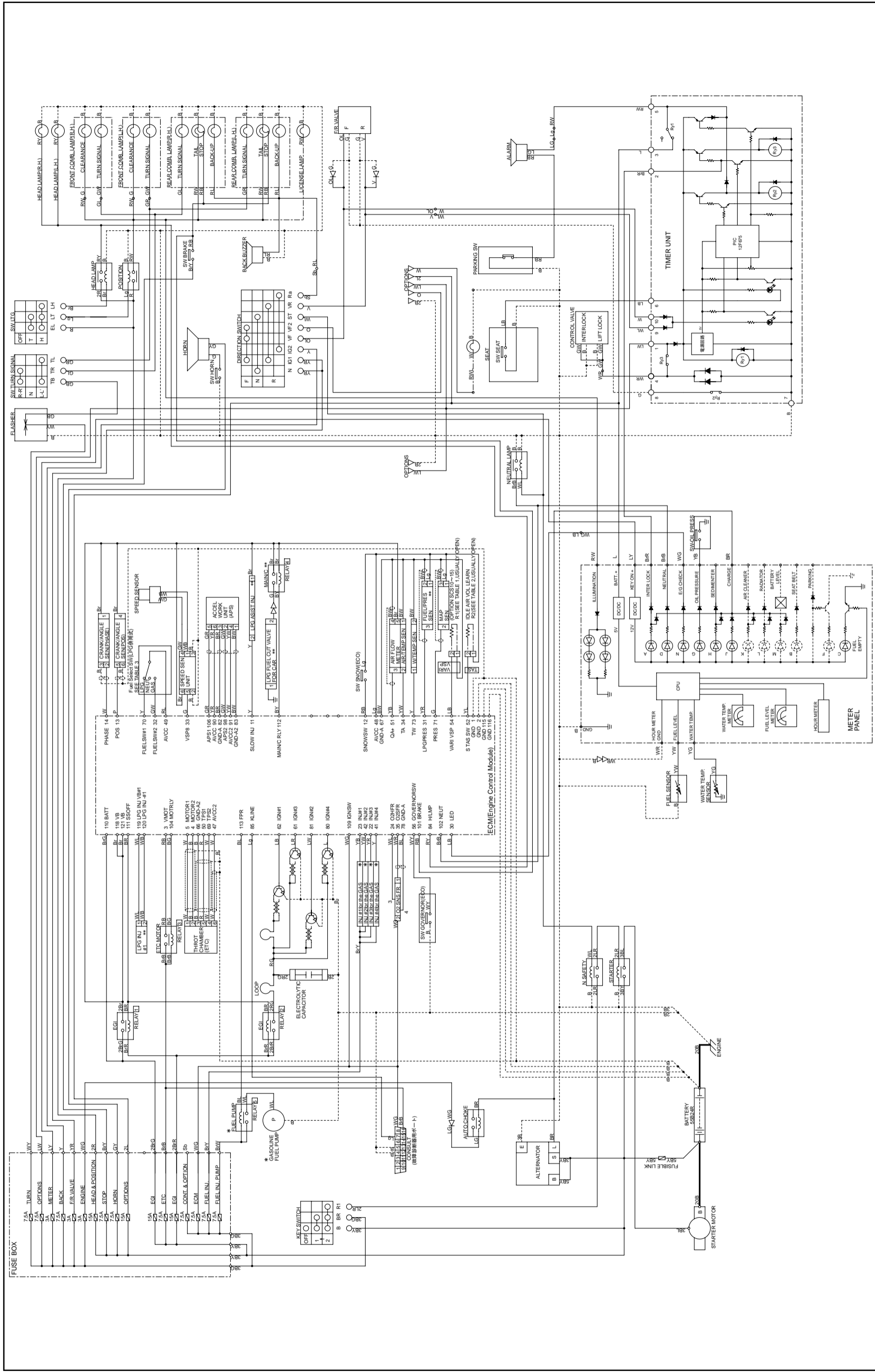

Fig. 8.7 Wiring Diagram (K21, K25)

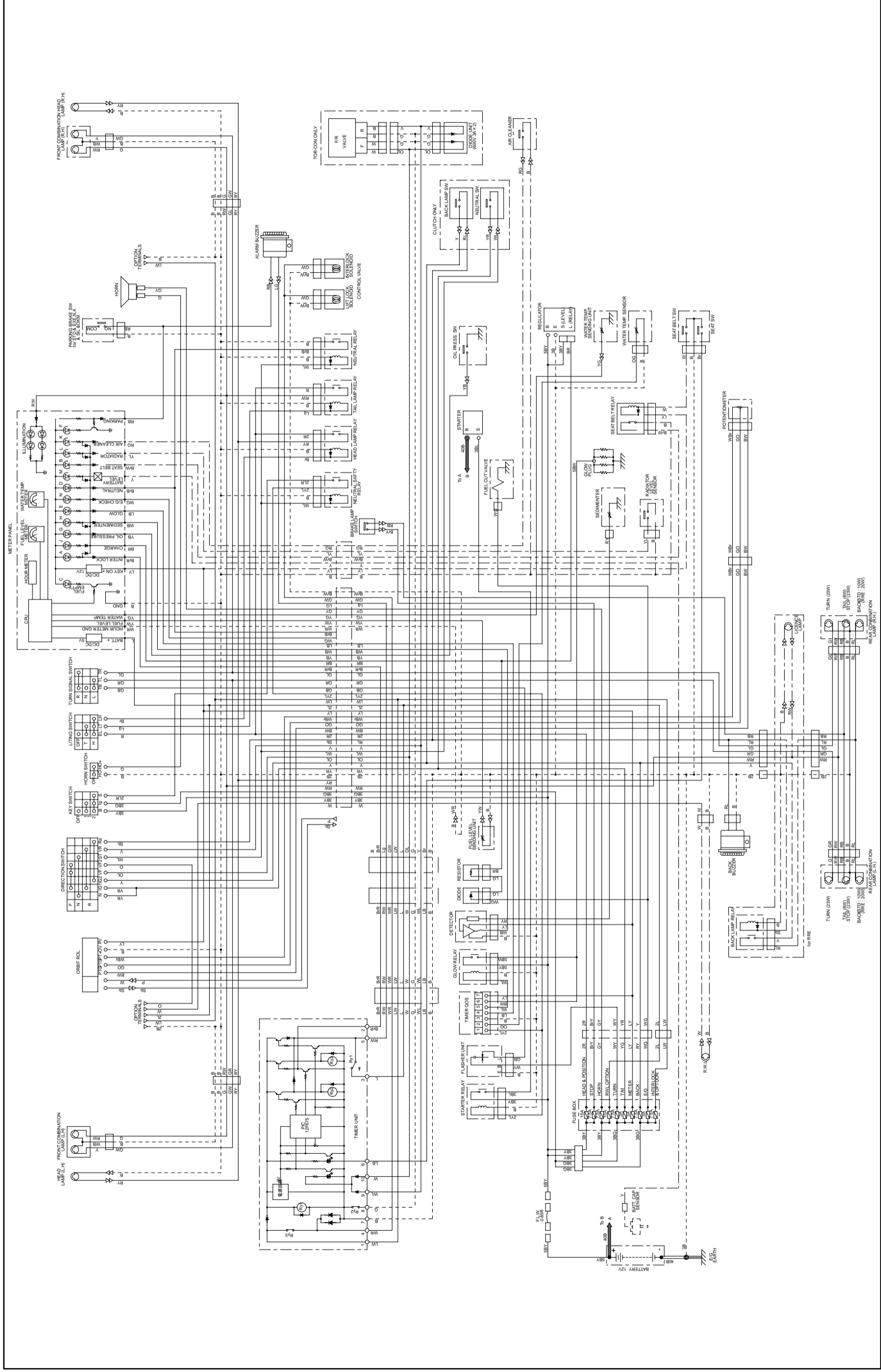

Fig. 8.8 Wiring Diagram (TD27, QD32)

No. SEF-0F7BE

Issued: February, 2007
Revised: February, 2010

TCM CORPORATION

MARKETING GROUP:

1-15-5, Nishi-shimbashi, Minato-ku, Tokyo
105-0003, Japan

FAX: JAPAN +81-3-35918154

All rights reserved

JB-1002010(HO) Printed in Japan