

281

Spezialnähmaschine

Serviceanleitung

D

Service Instructions

GB

Service Instructions

CN

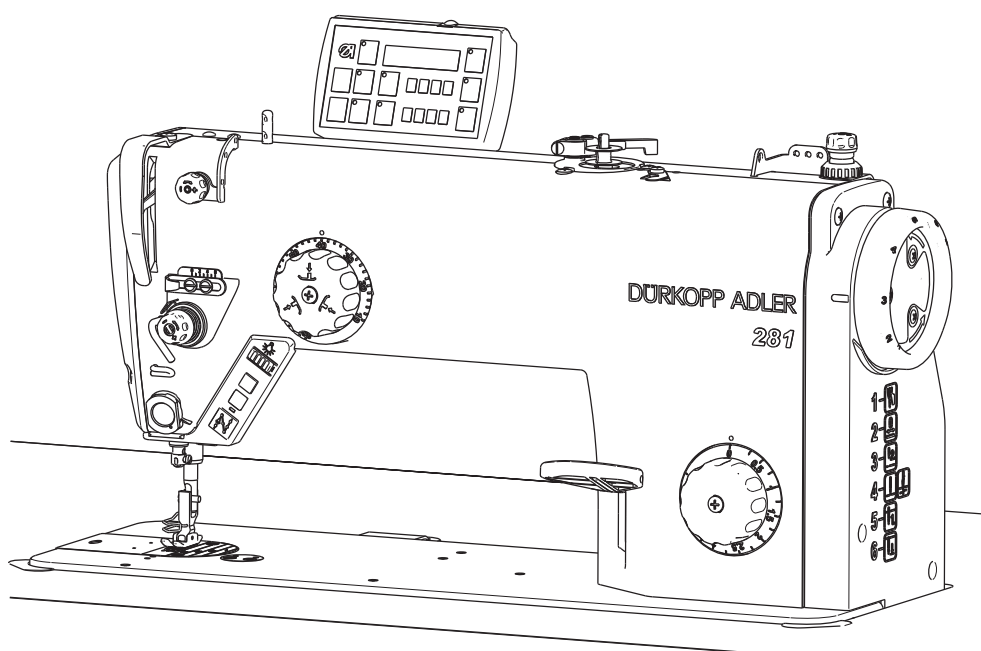

Manufacturer: Dürkopp Adler Manufacturing (Shanghai) Co., Ltd.
1201 Luoshan Road, Pudong New Area, Shanghai 200135, China
Contact: Dürkopp Adler AG, PO Box 17 03 51, D-33703 Bielefeld, Potsdamerstr. 190, D-33719 Bielefeld,
Phone +49 (0) 521 9 25 00, Fax +49 (0) 521 9 25 24 35, www.duerkopp-adler.com
Manufacturer: Dürkopp Adler Manufacturing (Shanghai) Co., Ltd.
1201 Luoshan Road, Pudong New Area, Shanghai 200135, China
Contact: Dürkopp Adler AG, PO Box 17 03 51, D-33703 Bielefeld, Potsdamerstr. 190, D-33719 Bielefeld,
Phone +49 (0) 521 9 25 00, Fax +49 (0) 521 9 25 24 35, www.duerkopp-adler.com

Ausgabe / Edition:
01/2009

Änderungsindex
Rev. index: **00.0**

Printed in China

Teile-Nr./Part.-No.:
0791 281641

Alle Rechte vorbehalten.

Eigentum der Dürkopp Adler und urheberrechtlich geschützt. Jede, auch auszugsweise Wiederverwendung dieser Inhalte ist ohne vorheriges schriftliches Einverständnis der Dürkopp Adler verboten.

All rights reserved.

Property of Dürkopp Adler and copyrighted. Reproduction or publication of the content in any manner, even in extracts, without prior written permission of Dürkopp Adler, is prohibited.

All rights reserved.

Property of Dürkopp Adler and copyrighted. Reproduction or publication of the content in any manner, even in extracts, without prior written permission of Dürkopp Adler, is prohibited.

Copyright © Dürkopp Adler - 2009

General safety instructions

The non-observance of the following safety instructions can cause bodily injuries or damages to the machine.

1. The machine must only be commissioned in full knowledge of the instruction book and operated by persons with appropriate training.
2. Before putting into service also read the safety rules and instructions of the motor supplier.
3. The machine must be used only for the purpose intended. Use of the machine without the safety devices is not permitted. Observe all the relevant safety regulations.
4. When gauge parts are exchanged (e.g. needle, presser foot, needle plate, feed dog and bobbin) when threading, when the workplace is left, and during service work, the machine must be disconnected from the mains by switching off the master switch or disconnecting the mains plug.
5. Daily servicing work must be carried out only by appropriately trained persons.
6. Repairs, conversion and special maintenance work must only be carried out by technicians or persons with appropriate training.
7. For service or repair work on pneumatic systems, disconnect the machine from the compressed air supply system (max. 7-10 bar). Before disconnecting, reduce the pressure of the maintenance unit. Exceptions to this are only adjustments and functions checks made by appropriately trained technicians.
8. Work on the electrical equipment must be carried out only by electricians or appropriately trained persons.
9. Work on parts and systems under electric current is not permitted, except as specified in regulations DIN VDE 0105.
10. Conversion or changes to the machine must be authorized by us and made only in adherence to all safety regulations.
11. For repairs, only replacement parts approved by us must be used.
12. Commissioning of the sewing head is prohibited until such time as the entire sewing unit is found to comply with EC directives.
13. The line cord should be equipped with a country-specific mains plug. This work must be carried out by appropriately trained technicians (see paragraph 8).



It is absolutely necessary to respect the safety instructions marked by these signs.

Danger of bodily injuries !

Please note also the general safety instructions.



Part 3: Service Instructions Class 281

(Edition 01/2009)

1.	General	
1.1	Tools and Gauges	3
1.2	Adjusting aids	4
2.	Feeding and sewing equipment	
2.1	Timing of the thrust eccentric	5
2.2	Timing of the lifting cam	6
2.3	Feed dog height and inclination	7
2.4	Feed dog position within the throat plate	8
2.5	Stitch length limitation	9
2.6	Stitch length symmetry	10
3.	Sewing foot height and sewing foot lifting	
3.1	Pressure-bar height	11
3.2	Mechanical sewing foot lifting	12
3.2.1	Lifting motion and lifted sewing foot height	12
3.3	Electromagnetic sewing foot lifting	13
3.3.1	Sewing foot lifter solenoid position	13
3.3.2	Mounting the sewing foot lifting solenoid	14
3.3.3	Replacing the shock absorbing washer of the sewing foot lifter solenoid	16
3.4	Sewing foot pressure	18
4.	Thread-guiding parts	
4.1	Releasing the needle thread tension	19
4.2	Thread take-up spring	20
4.3	Thread regulator	21
5.	Needle bar height	22
6.	Hook setting	
6.1	Looping stroke and distance between the hook point and needle	23
6.2	Bobbin case holder	24
7.	Thread trimmer	
7.1	Control cam for the knife motion	25
7.1.1	Control cam position	25
7.1.2	Distance between the roller and thread trimmer cam	26
7.2	Hooked knife	27
7.3	Setting the cutting pressure	28

8.	Setting the bobbin winder	
8.1	Switching off the bobbin winder	29
8.2	Winding form of the bobbin	30
8.3	Winding tightness	30
9.	Filling up oil (gear box)	31
10.	Hook lubrication	
10.1	Setting the oil quantity for the hook	33
11.	Maintenance	34

1. General

The present service instruction describes the adjustment of the special sewing machine 281.



ATTENTION!

The operations described in the service instructions must only be executed by qualified staff or correspondingly instructed persons respectively!



Caution: Risk of injury !

In case of repair, alteration or maintenance work turn off the main switch and make sure to protect the machine from powering up accidentally.

Carry out adjusting operations and functional tests of the running machine only under observation of all safety measures and with utmost caution.

The present service instruction describes the adjustment of the sewing machine in an appropriate sequence. Please observe in this connection that various setting positions are interdependent. Therefore it is absolutely necessary to perform the adjustment following the described order.

For all setting operations of parts involved in the stitch formation use a new needle without any damage.





Machine covers having to be screwed off and on again for checking and adjusting operations are not mentioned in the text.

Please note:

The shaft of the special sewing machine 281 is provided with flat spots. This facilitates the adjustment considerably.

In case of adjustments on flat spots the first screw in rotation direction is put on such a flat spot.

1.1 Tools and Gauges

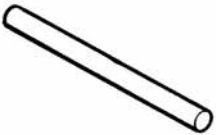
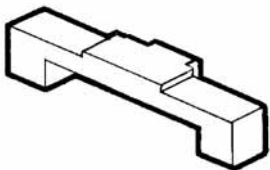
Art	Size	Figure
Allen key	5 4 3 2.5 2 1.5	
Screw driver Flat tip Flat tip Flat tip Cross tip	0.7 x 4,5 0.3 x 3 0.7 x 4.5 B2 -H	
Open-end wrench	10	
Gauge 0281 801819		Needle bar height for needle diameter 1.62 mm
Gauge 0281 800300		Needle bar height for needle diameter 2.00 mm
Setting pin 9301 022608		For locking the machine at position 1 - 6
Gauge 0281 800290		Feed dog height / Needle bar height

1.2 Adjusting aids

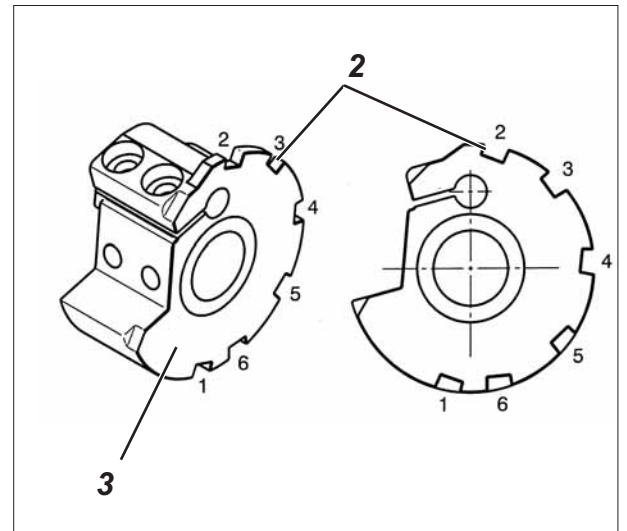
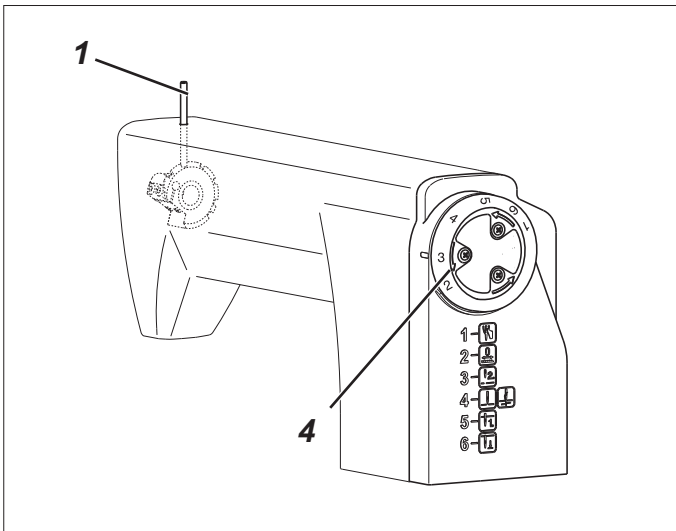

The sewing machine can be locked in six different setting positions with the locking pin 1 and the arresting notches 2 on the arm shaft crank 3.

The crank has six notches which are marked on the handwheel by the figures 1, 2, 3, 4, 5 and 6. In conjunction with marking 4 the figures indicate the position of the notches in which the machine can be locked with locking pin 1.

The figures simplify the finding of the arresting notches. A precise setting can only be ensured by arresting the machine at the provided notches.

GB

The following items should be adjusted in the various positions:

Pos.	Symb.	Description
1		Loop stroke Distance between the hook point and needle
2		Feed dog standstill when stitch-length regulator moves feed dog height
3		2 nd needle position (thread lever upper dead centre)
4		Reference position machine head / Control cam for thread trimmer
5		1 st Needle position
6		Needle in lowest position

2. Feeding and sewing equipment

2.1 Timing of the thrust eccentric

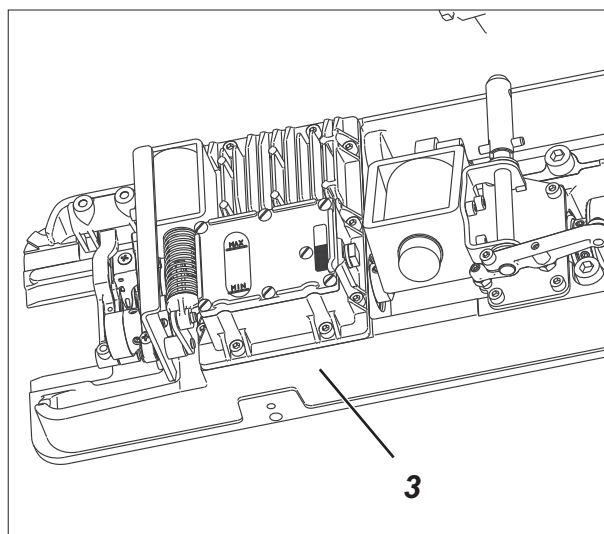
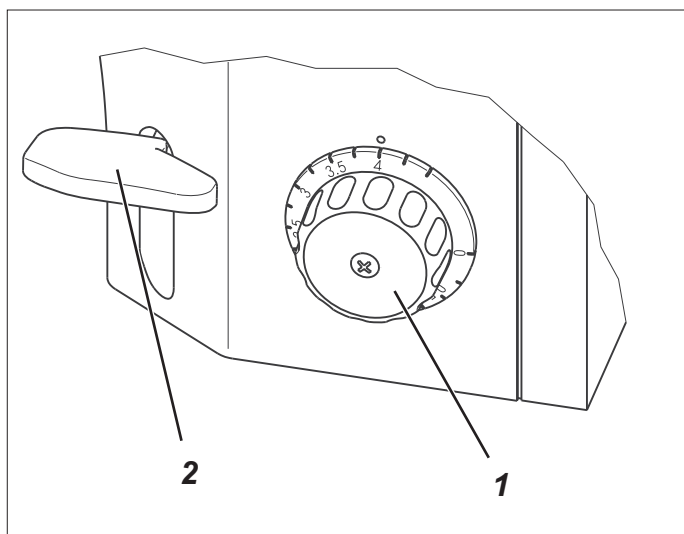

Caution: Risk of injury !

Turn the main switch off!
Check and set the feed standstill only when the machine is switched off.



ATTENTION!

The thrust eccentric in the gear box 3 is already optimally set ex factory.
The setting should preferably not be modified.



Standard checking

With the sewing machine arrested at locking position "2", there should be no feeding movement if the reverse feed lever 2 is actuated and the greatest stitch length is selected.

Correction

- Set the greatest stitch length at the setting wheel 1.
- Loosen the screws 5 at the lower toothed belt wheel 4.
- Turn the lower shaft accordingly.
- Fasten the screws 5 at the lower toothed belt wheel 4.

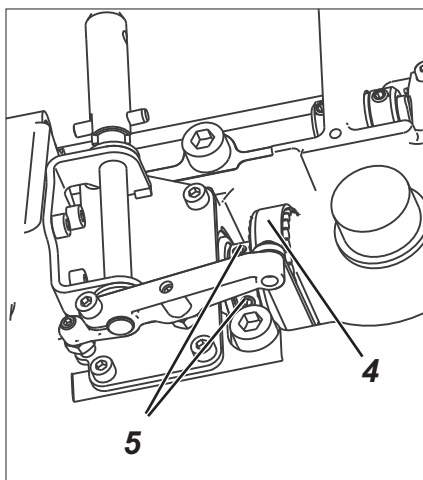

ATTENTION!

Should the lower shaft be misaligned, the following positions must also be re-adjusted again:

- Hook (see chapter 6.1)
- Thread trimmer cam (see chapter 7.11)
- Lifting cam (see chapter 2.2)

2.2 Timing of the lifting cam

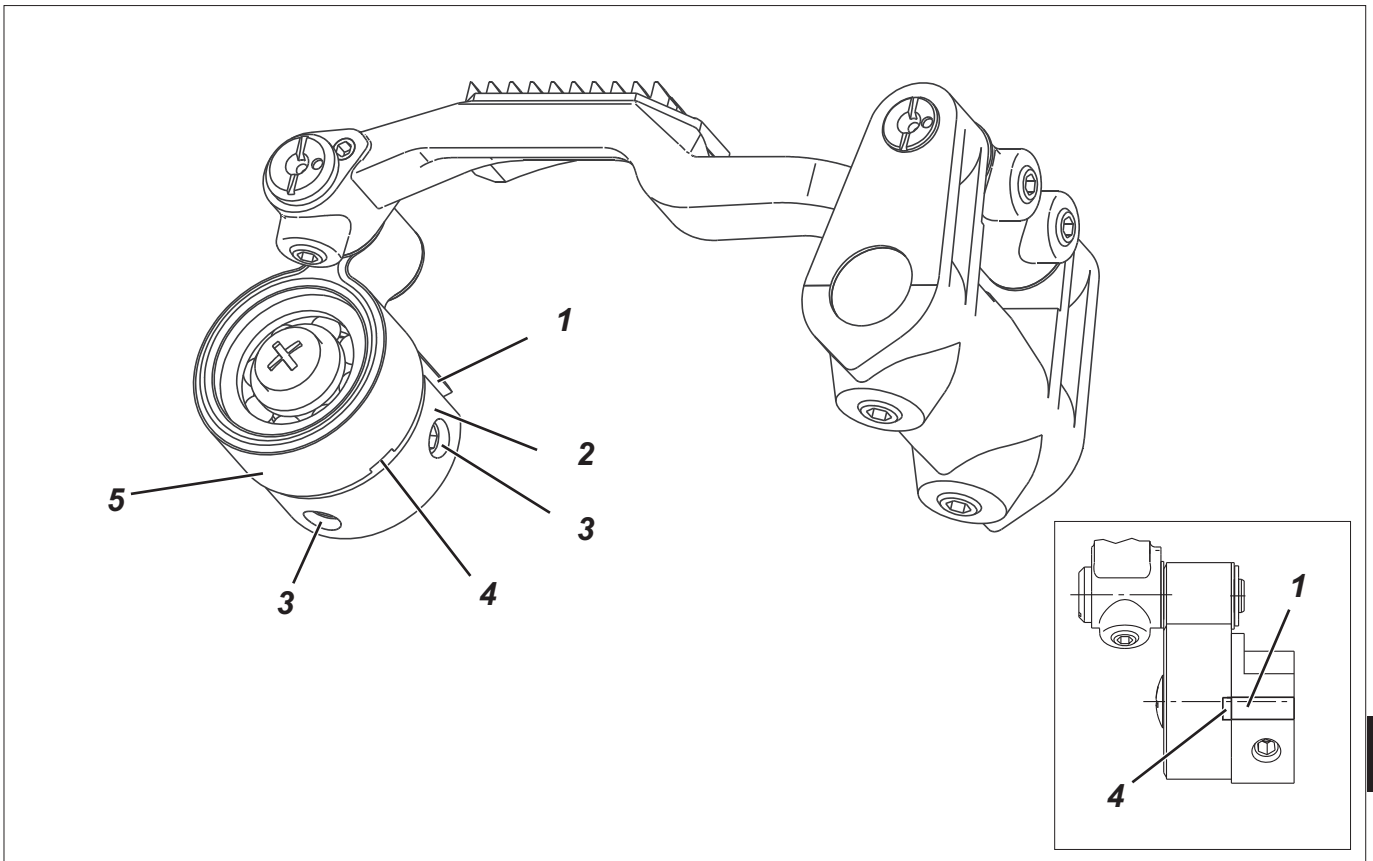

Caution: Risk of injury !

Turn the main switch off!

Check and set the lifting cam only when the machine is switched off.

Standard checking

With the sewing machine arrested at locking position "2", align the notches 1 (of the lifting cam 2) and 4 (of the traction rod 5).

Correction timing of the lifting cam

- Arrest the sewing machine at locking position "2".
- Loosen both screws 3 of the lifting cam 2.
- Turn the lifting cam 2.
The notches 1 and 4 must be aligned.
- Tighten both screws 3 of the lifting cam 2 again.



2.3 Feed dog height and inclination

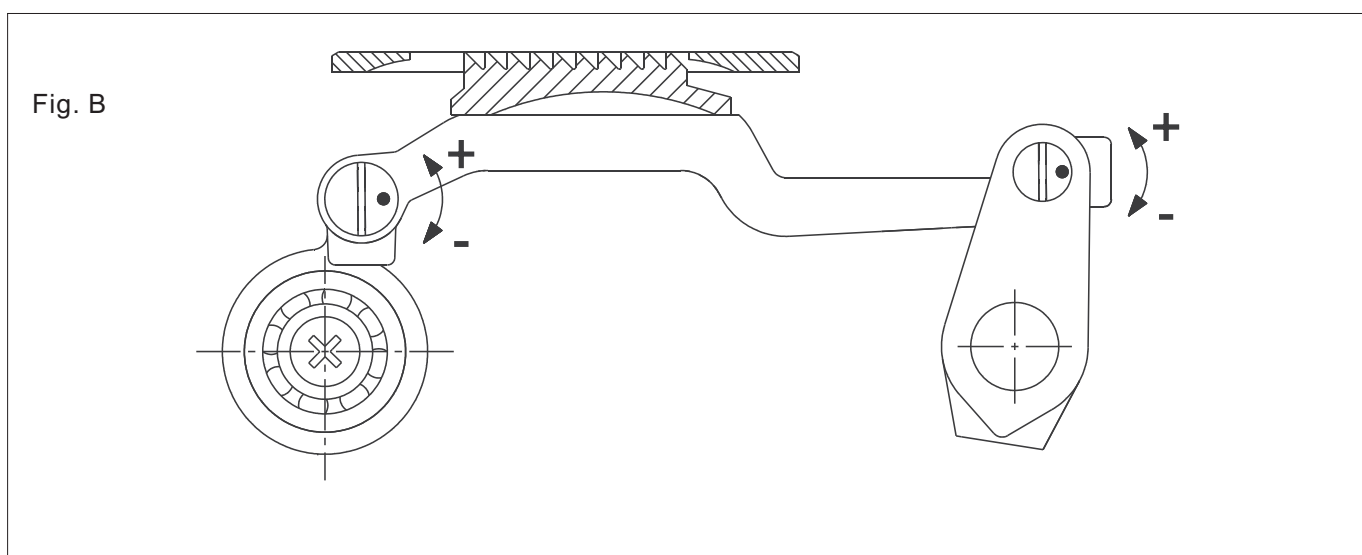
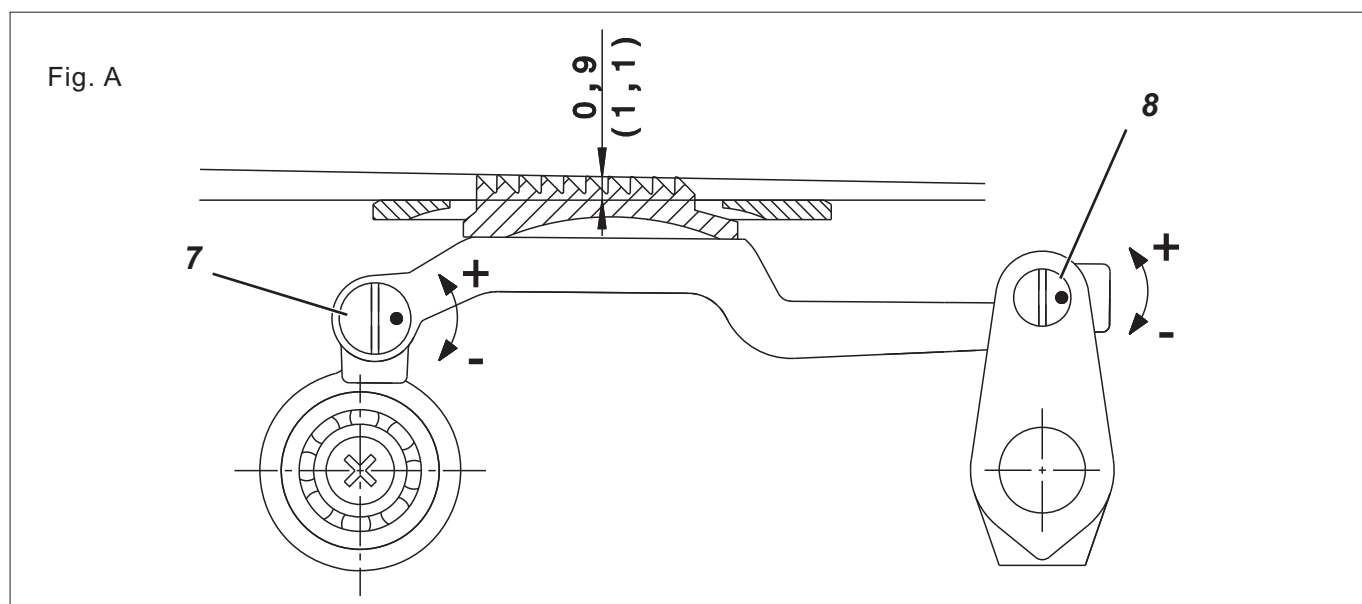

Standard checking

Fig. A

The emerging height of the feed dog over the throat plate, its angle of climb or the parallelism to the throat plate can be set via eccentrics 7 and 8.

With the sewing machine arrested at locking position "2", the height of the centre of the throat plate (at the needle hole) is set ex factory:

- 0.9 mm with fine toothed feed dog
- 1.1 mm with coarse toothed feed dog

Thereby the feed dog is slightly rising from front to rear.

Fig. B

With this setting, the feed dog is parallel to the throat plate when emerging.



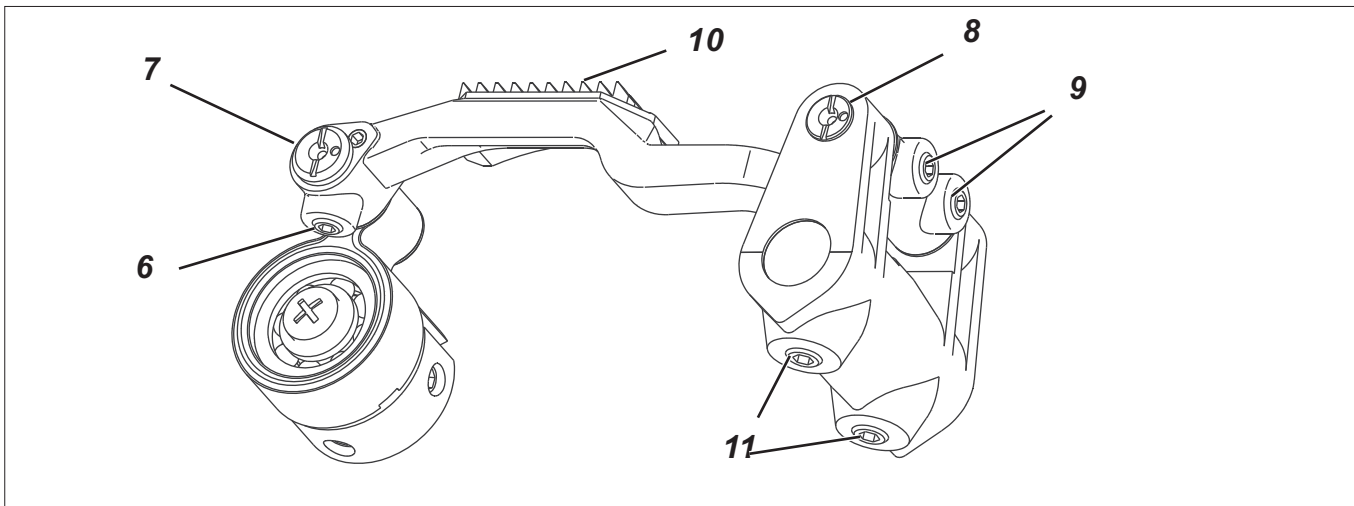

Caution: Risk of injury !

Turn the main switch off!

Check and set the feed dog height and inclination only with the sewing machine switched off.



Correction feed dog height

- Arrest the sewing machine at locking position "2".
- Loosen screws 6 and 9.
- Turn the eccentric bolts 7 and 8.
In its highest position, the feed dog should protrude by 0.9 (1.1) mm from the throat plate in the region of the needle hole.
- Adjust the height and the inclination via the eccentrics 7 and 8.
Keep in mind that the adjusting of both eccentrics are interdependent from each other.
- Fasten screws 6 and 9 again.

GB

2.4 Feed dog position within the throat plate

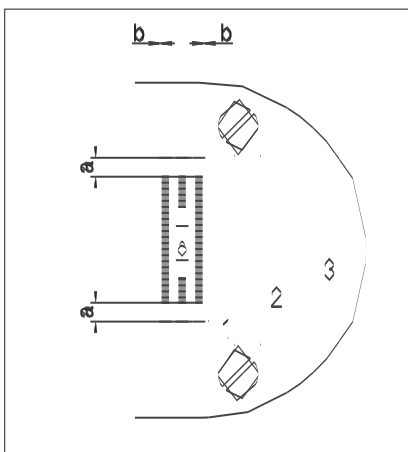

Rule

With the sewing machine arrested at locking position "2", the feed dog should be symmetric.

The distance is similar at the front and the rear.



Correction

- Arrest the sewing machine at locking position "2".
- Loosen screw 11.
- Adjust the symmetry.
- Fasten the screws 11.
The lateral clearance b must still be kept.

2.5 Stitch length limitation

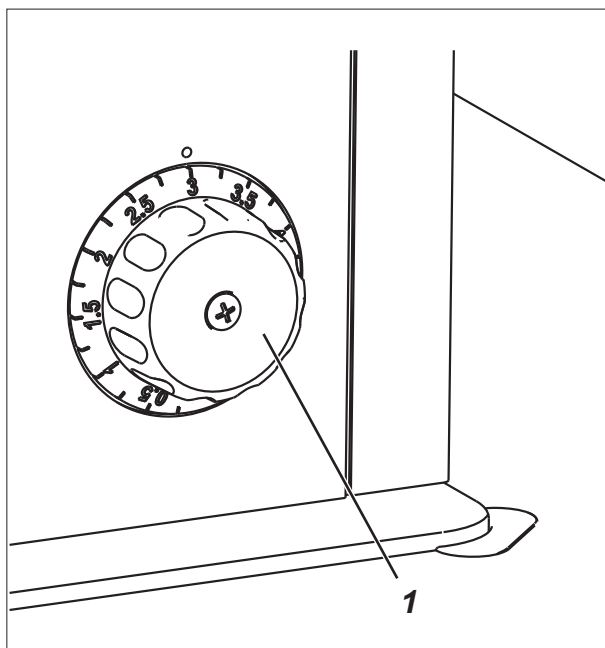
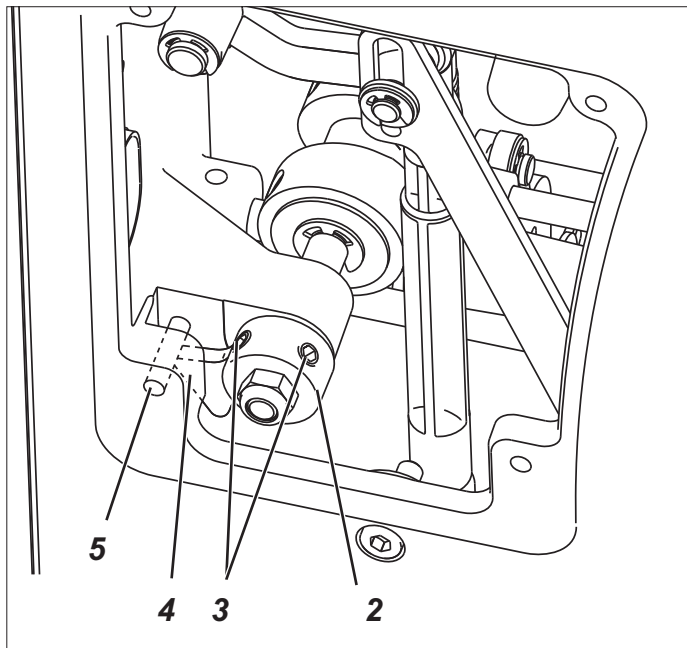

Caution: Risk of injury!

Turn off the main switch!

Check and set the stitch length limitation only with the sewing machine switched off.

Standard checking

The maximum stitch length for the sewing machine is 4.5 mm.

With sewing equipment designed for smaller stitch length, the stitch length must also be limited accordingly, in order to avoid damaging the sewing machine or the sewing equipment.

Limiting the maximum stitch length

- Set the allowed maximum stitch length for the sewing equipment on the setting wheel 1.
- Loosen both screws 3 of the limiting block 2.
- Turn the limiting block clockwise against the threaded pin 5.
- Fasten both screws 3 again.

2.6 Stitch length symmetry

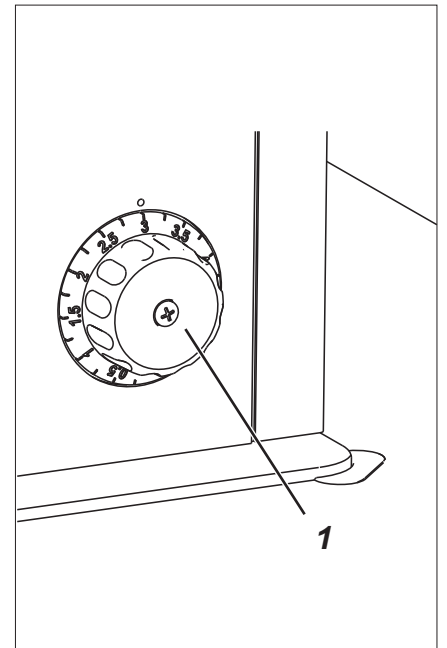
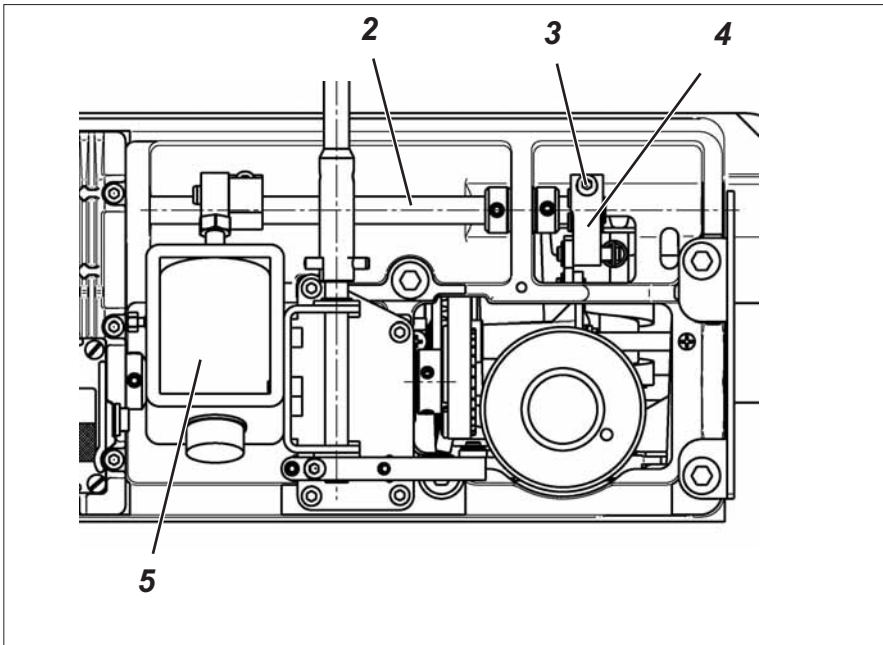

Caution: Risk of injury!

Turn off the main switch! Check and set the stitch length symmetry only with the sewing machine switched off.

GB

Standard checking

The forward and reverse stitch length (4.0 mm) are already set ex factory.

A verification can be done by using a cardboard as a sewing material and sewing 10 stitch length (11 stitching) forward and next to it 10 stitch length (11 stitching) reverse without thread with the slowest speed.

The total length of the 10 stitches in both directions should be the same.

It may be necessary to re-adjust the symmetry of the stitch length after repairs.

Correction

- Set the maximum stitch length on the setting wheel 1.
- Loosen the screw 3 in the clamping block 4.
- Turn the shaft 2 in the clamping block 4.
- Fasten the screw 3.
- Check the stitch length again and set it anew if necessary.

Please note:

Even a slight twisting of the shaft leads to an essential change of the stitch length.

This task must be carried out meticulously.

Furthermore it is important to make sure that when latching (with the greatest stitch length set), the latch solenoid 5 does not hit its inside or outside end position in order to avoid knocking noises or to prevent from wearing out.

3. Sewing foot height and sewing foot lifting

The maximum sewing foot lifting stroke amounts to:

- 12 mm with machines with electromagnetic sewing foot lifting.
- 14 mm with machines with knee lever.
- 9 mm factory setting.

3.1 Pressure-bar height

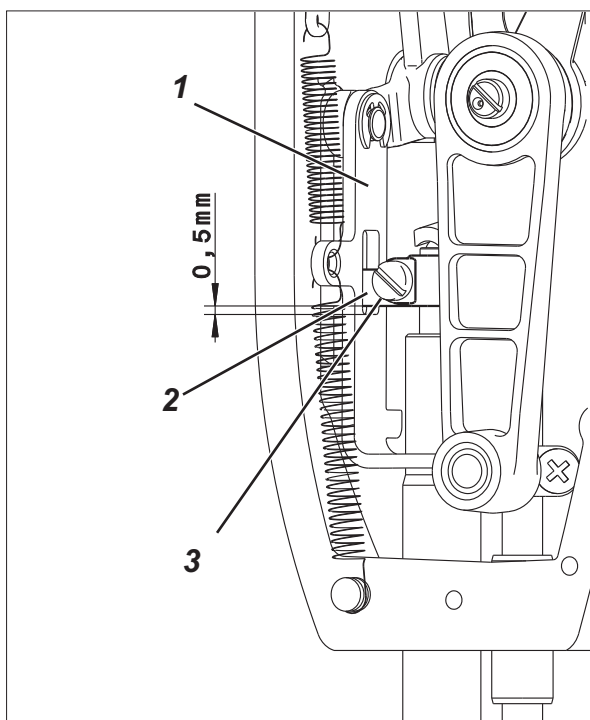

Caution: Risk of injury!

Turn off the main switch!

Check and set the pressure-bar height only with the sewing machine switched off.

Standard checking

When the sewing foot sole 4 rests on the throat plate, a gap of 0.5 mm should be available between the block 2 and the traction bracket 1.

Correction

- Remove the face cover.
- Loosen the screw 3.
- Press the sewing foot downward against the throat plate. This setting should not take place against the emerging feed dog!
- Shift the block 2 in a way that a gap of 0.5 mm is available between the block 2 and the draw angle 1.
- Align the sewing foot so that the needle can stitch in the middle of the slit of the sewing foot and fasten the screw 3 again.
- Fix the face cover again.



4

3.2 Mechanical sewing foot lifting

3.2.1 Lifting motion and lifted sewing foot height

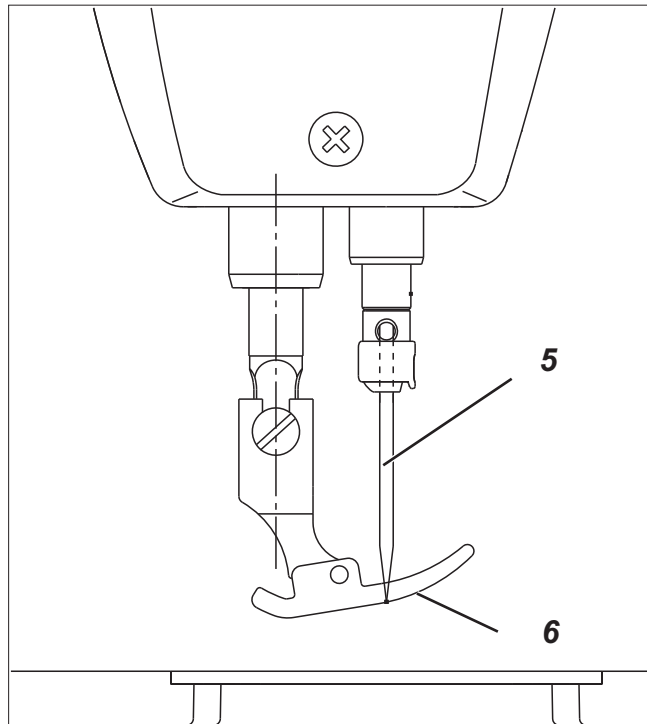
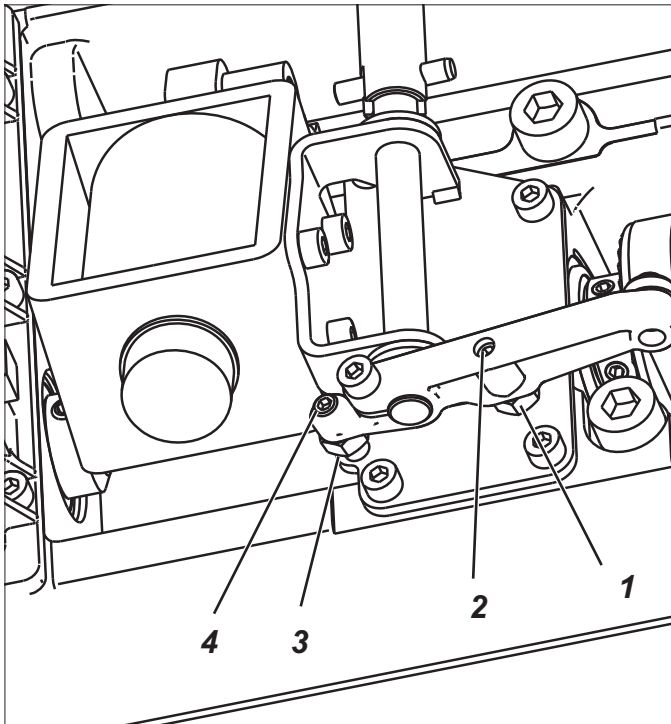

GB



Caution: Risk of injury!

Turn off the main switch! Check and set the knee lever only with the sewing machine switched off.

Standard checking

With the sewing foot resting on the throat plate, before the lifting movement begins a lost motion should be perceptible at the knee lever.

The sewing foot lifting should be set so high in a way that the needle point 5 in arrested position (locking position 3) must not come above the slit of the sewing foot 6.

Correction lifter motion (lower position)

- Loosen the nut 3.
- Adjust the screw 4.
With the sewing foot resting on the throat plate, a lost motion should be perceptible at the knee lever.
- Fasten the nut 3 again.

Correction lifted sewing foot height

- Arrest the sewing machine at locking position "3".
- Loosen the nut 1.
- Adjust the lifting height through stop screw 2.
- Fasten the nut 1 again.



3.3 Electromagnetic sewing foot lifting

3.3.1 Sewing foot lifter solenoid position

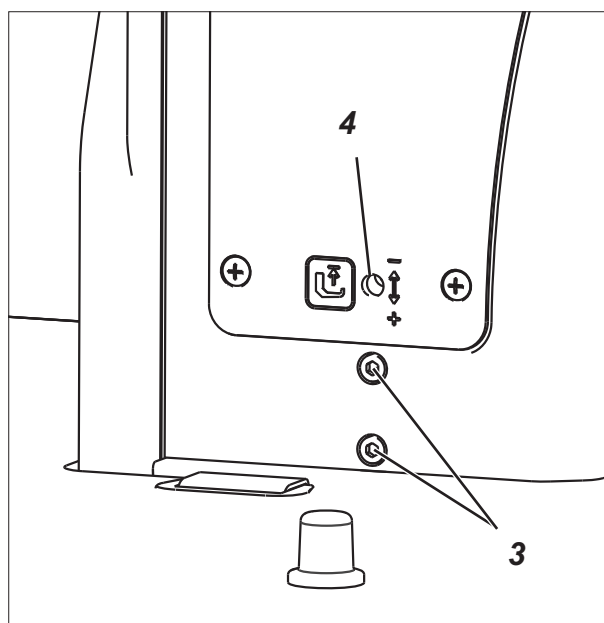
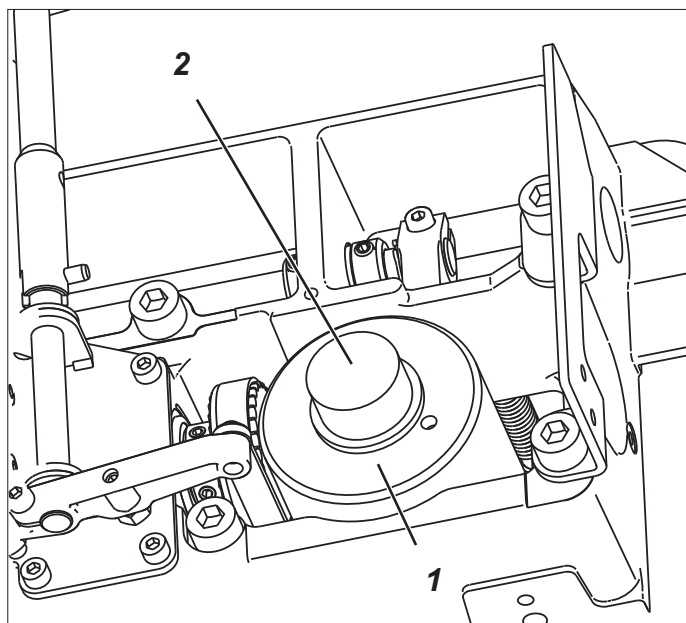

Caution: Risk of injury!

Turn off the main switch!

Check and set the sewing foot lifting only with the sewing machine switched off.

Standard checking

When operated, the anchor 2 of the solenoid 1 must always reach its internal final position, because its power consumption will be reduced to 30% after a sewing foot lifting.

The sewing foot lifting should be set so high in a way that the needle point 5 in arrested position (locking position 3) must not come above the slit of the sewing foot 6.

Correction

- Loosen screw 3.
- Introduce a screw driver through the hole 4 and put it in the bracket of the sewing foot lifting solenoid.
- Change the position of the solenoid by swivelling the screw driver upwards or downwards:
 - Swivel the screwdriver handle upwards = smaller stroke
 - Swivel the screwdriver handle downwards = greater stroke
- Fasten both screws 3 again.

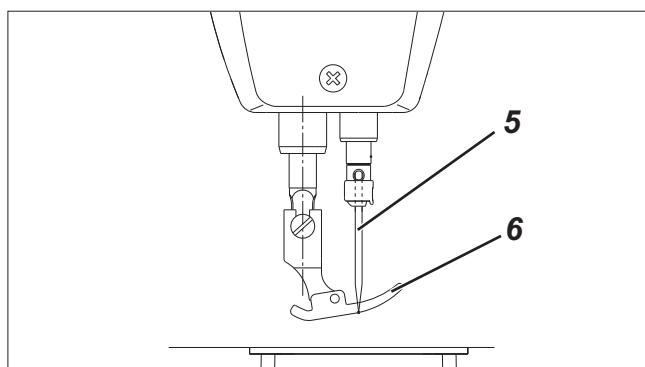

3.3.2 Mounting the sewing foot lifting solenoid

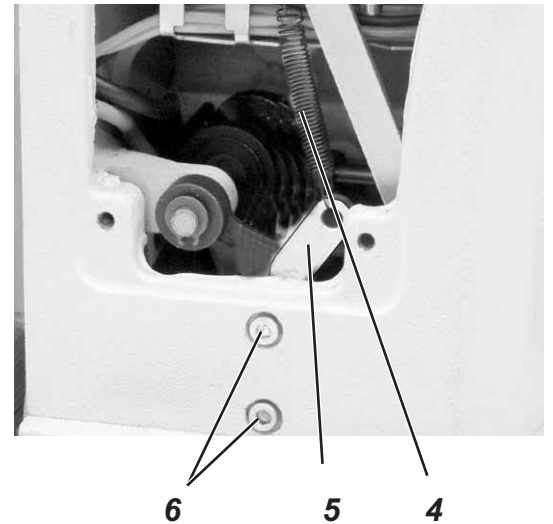
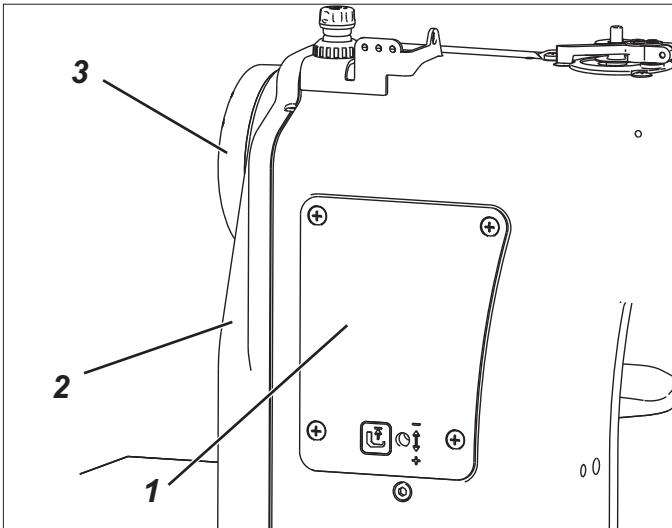

- Unscrew the handwheel 3, covering 2 and cover 1.
- Unclamp the spring 4.
- Loosen the screws 6 and remove the mounting flange 5.

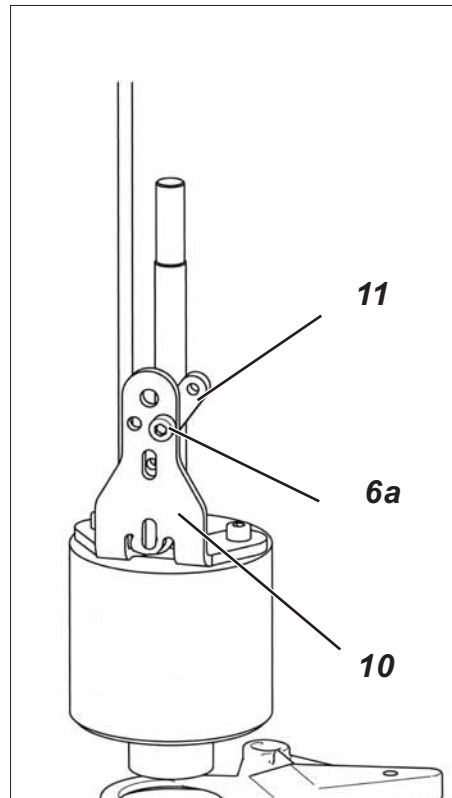
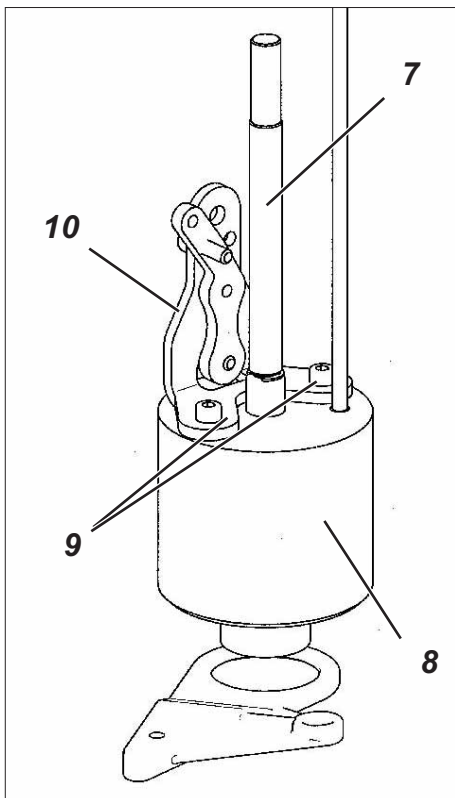

- Screw the holder 10 to the solenoid 8 using the screws 9 provided.
- Fit the push rod 7 to the solenoid.
- Screw the mounting flange 11 that has been removed to the holder 10 using one of the screws 6.

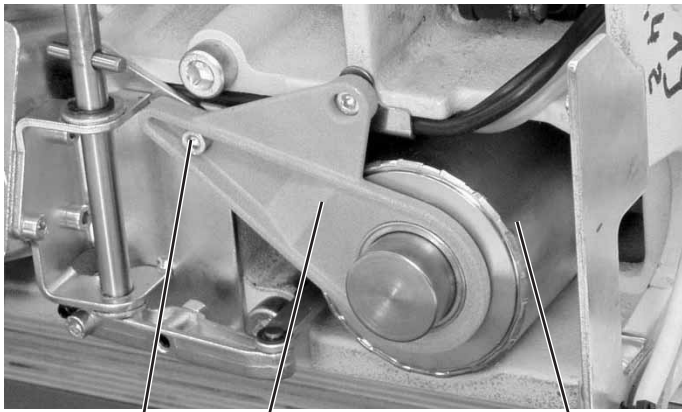

14 **13** **8**

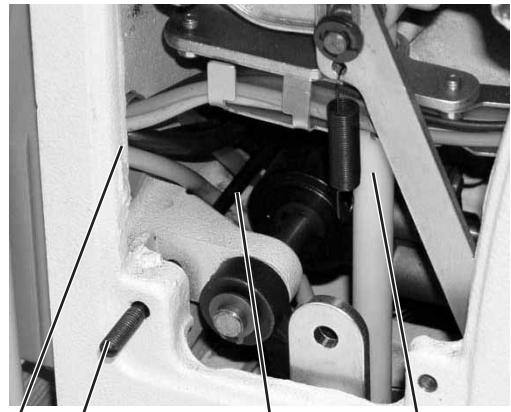

18 **17** **16** **15**

- Tilt the machine head backwards.
- Loosen screw 14.
- Using the mounting aid 13, push the pre-assembled sewing foot lifting solenoid upwards in a way that the push rod 15 gets engaged in the upper guide bore hole.
- Fasten the mounting aid 13 with the screw 14.
- Unscrew the threaded pin 17.
- Push all the cables to the left of the shaft 16 of the threaded pin 17 and fasten the threaded pin again.
- Lead the cable of the sewing foot lifting solenoid to the rear side of the machine through the drilled hole 18.

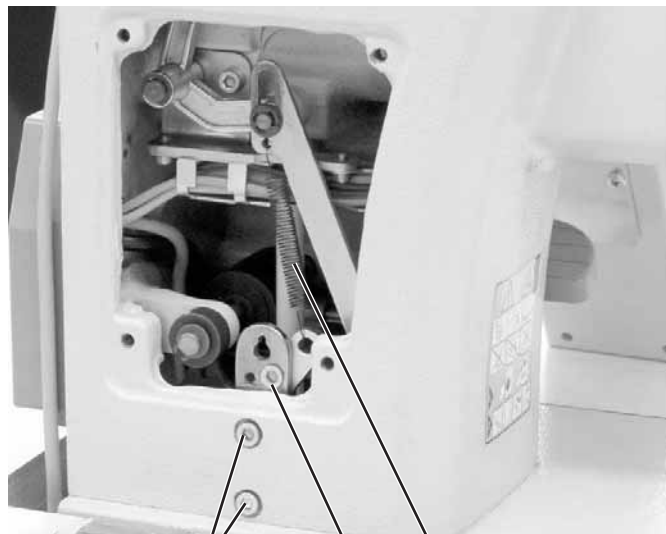

6 **6a** **4**

- Tilt the sewing machine head to the front.
- Screw the holder 10 to the housing using one of the screws 6.
- Unscrew the screw 6a and screw it into the second mounting hole of the holder.
- Loosen the screw 14, remove the mounting aid and fasten the screw 14 again.
- Put in the spring 4.

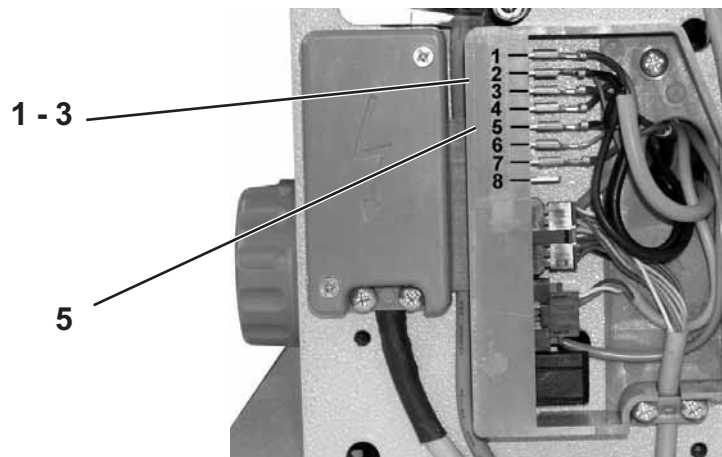

- Connect the cable of the sewing foot lifting solenoid to the terminal blocks, one wire to one of the terminal from 1 to 3 and the second one to the terminal 5.
- If necessary, set the sewing foot height anew (see chapter 3.3.1).
- If necessary activate the sewing foot lifting solenoid (see operating instructions for the control unit).

Please note!

The removal of the sewing foot lifting solenoid is the reverse of the mounting procedure.

GB

3.3.3 Replacing the shock absorbing washer of the sewing foot lifter solenoid



Caution: Risk of injury!

Turn off the main switch!

Proceed to the removal of the sewing foot lifting solenoid with the sewing machine switched off!

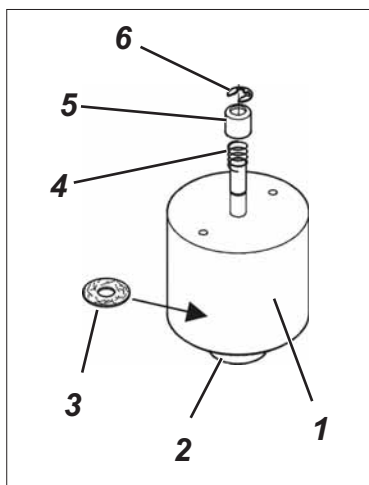

After years of intensive use, a dimensional change of the shock absorbing washer 5 may occur. This is noticeable by the slower lowering of the sewing foot or an impact noise when the solenoid is operated. It may signify that before the foot has reached the material to be sewn completely it has already started to sew (risk of skipped stitches at the seam beginning).

- Remove the lifting solenoid 1.
- Remove the lock washer 6.
- Remove spring 4 and bush 5.
- Remove the anchor 2 from its housing.
- Replace the shock absorbing washer 3 (0271 001767).
- Put on spring 4 and bush 5.
- Fix the lock washer 6 again.
- Mount the lifting solenoid again (see chapter 3.3.2).

3.4 Sewing foot pressure

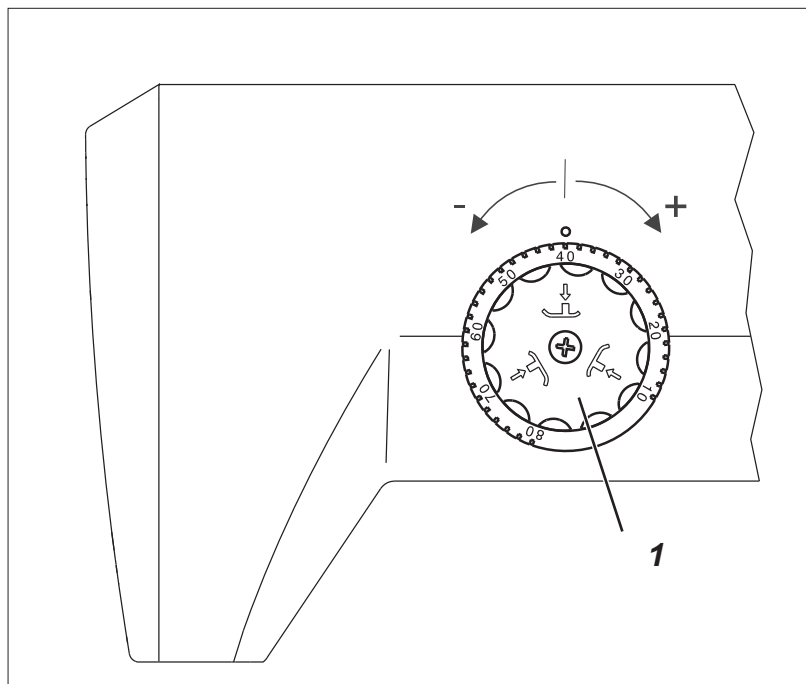

Standard checking

The figures on the setting wheel 1 gives the sewing foot pressure in "N".

(1kp = approx. 10N).

The required sewing foot pressure depends on the following parameters:

- Sewing speed
- Damping characteristics of the material to be sewn
- Number of plies (layers forming the material to be sewn)

The material that is to be sewn must not "swim".

However, the sewing foot should not exert more pressure than necessary, otherwise a strong shifting of the ply occurs (ruffling).

Correction

- Set the sewing foot pressure by turning the handwheel 1.

Increase the pressure = Turn it clockwise.

Decrease the pressure = Turn it counter-clockwise.

4. Thread-guiding parts

4.1 Releasing the needle thread tension

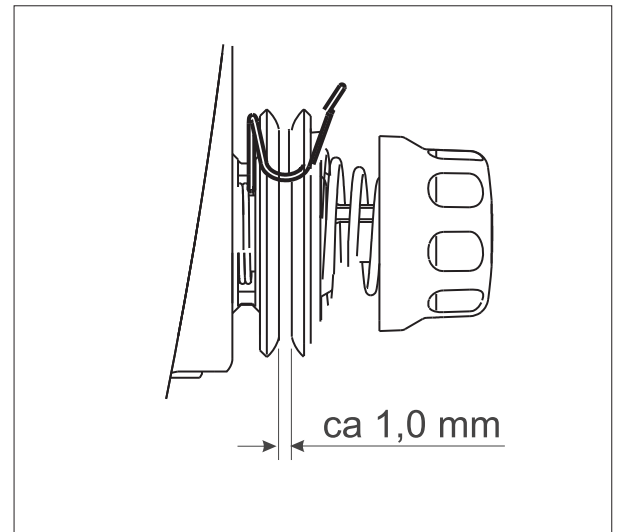
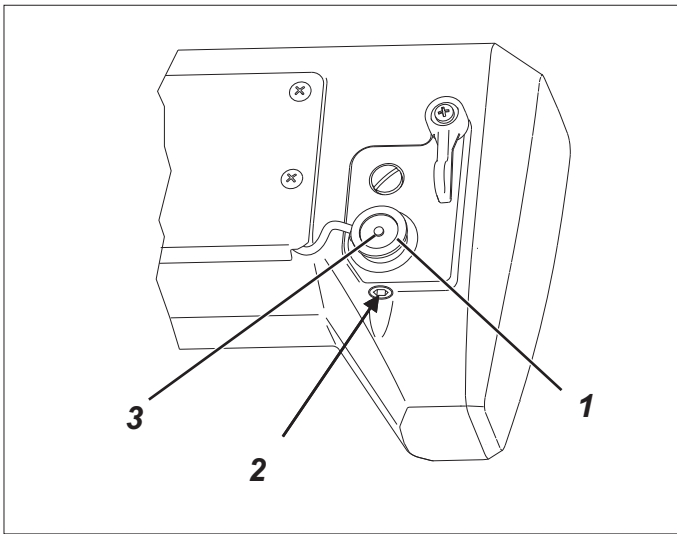

Caution: Risk of injury!

Turn off the main switch!

Check and set the releasing of the needle thread tension only when the machine is switched off.

Standard checking

Pressing on the axle 3 opens the thread tensioner by approx. 1 mm.

With the thread tensioner closed and with no thread between the tension discs the axle 3 should have a clearance of approx. 0.3 mm.

Correction

- Loosen the threaded pin 2.
- Move the solenoid 1 axially.
Check the following: distance approx. 1.0 mm / clearance 0.3 mm.
- Fasten the threaded pin 2 again.

4.2 Thread take-up spring

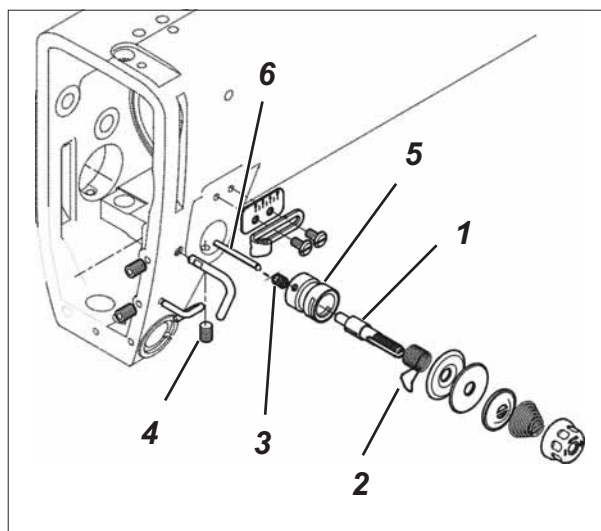
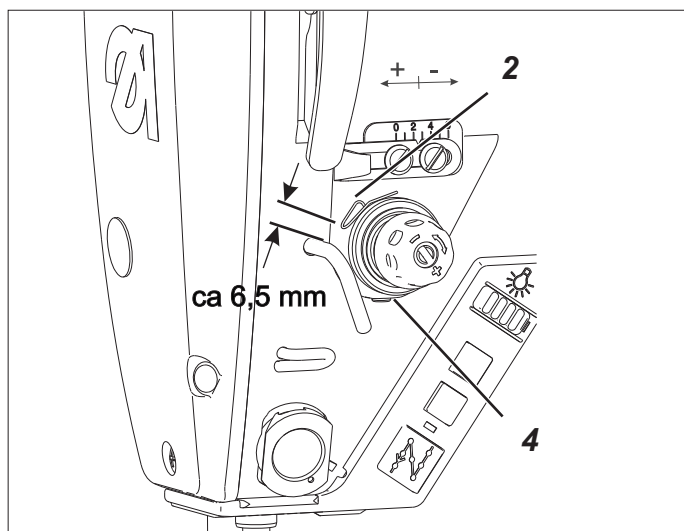

Caution: Risk of injury!

Turn off the main switch!

Check and set the thread take-up spring only with the sewing machine switched off.

Standard checking

The thread take-up spring 2 should keep the needle thread under tension at least until the needle point has penetrated the material to be sewn.

Correction spring tension

When removing the complete thread tension unit, please make absolutely sure not to lose the release pin 6 and to include it again when mounting the thread tension unit.

- Loosen the threaded pin 4.
- Unscrew the complete thread tension unit.
- Loosen the threaded pin 3.
- Adjust the tension strength by turning the tension bolt 1.
The tension of the thread take-up spring depends on the material being sewn and the thread used. The value should be between 20 and 50 cN (1 cN = 1 g).
- Fasten the threaded pin 3.
- Insert again the complete thread tension unit including the release pin 6.

Correction spring travel

- Loosen the threaded pin 4.
- Twist the bush 5.
The spring 1 must keep the needle thread under tension at least until the needle point has penetrated the material to be sewn. Recommended spring travel: 6.5 mm.
- Fasten the threaded pin 4 again.

4.3 Thread regulator

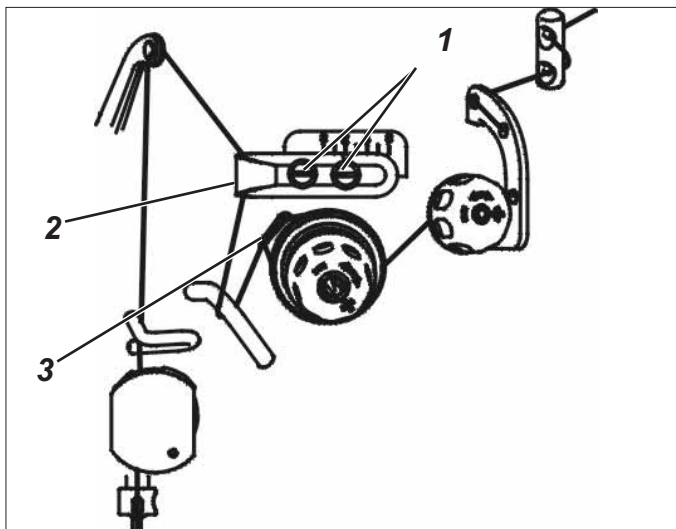

Caution: Risk of injury!

Turn off the main switch!

Check and set the thread regulator only when the machine is switched off.

GB

Standard checking

The setting of the thread regulator 2 depends on:

- Material thickness
- Thread size
- Stitch length.

It has to be set that the thread is guided around the hook and kept under control.

In the position "0" occurs the highest thread output as needed with particularly large stitch lengths and thick sewing threads.

The thread regulator is set ex factory between position "2" " and "3"

- Insert a fabric.
- Thread the needle and hook thread.
- Tilt the machine head backwards.
- Turn the handwheel slowly and check how tight the thread is guided around the hook.

If the thread regulator is set correctly the thread looping will run smoothly (without surplus), without jumping over the largest hook diameter.

In the process the thread take-up spring moved at most 0.5 mm.

Correction

- Loosen screw 1.
- Shift the thread regulator 2.
Thread regulator to the left = more thread.
Thread regulator to the right = less thread.
- Fasten screw 1.

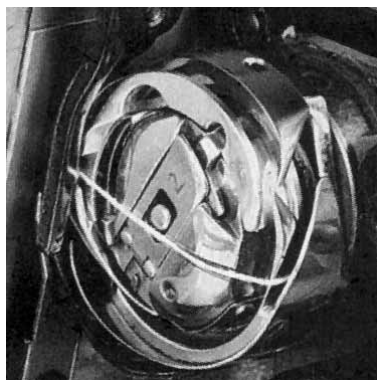

5. Needle bar height

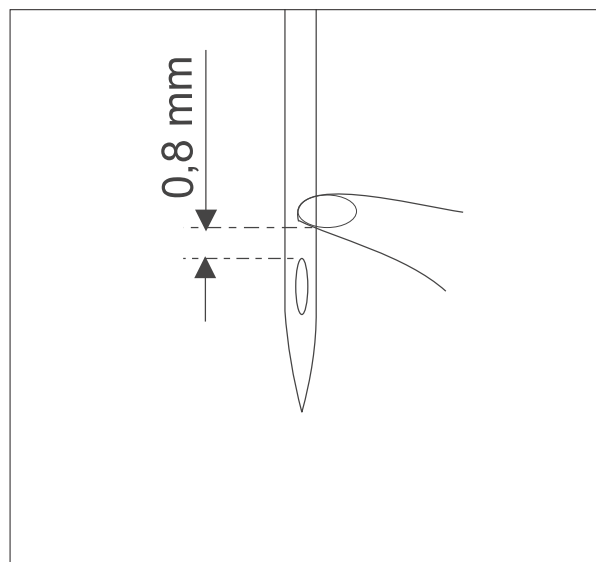
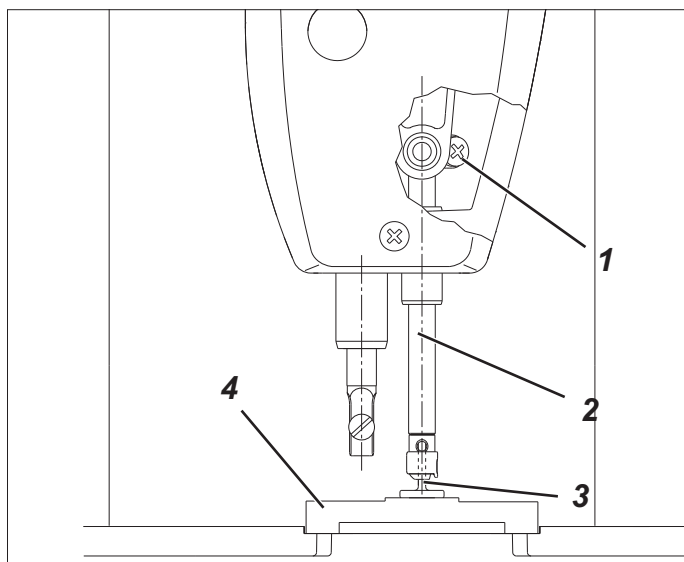

Caution: Risk of injury!

Turn off the main switch!

Check and set the needle bar height only with the sewing machine switched off.



ATTENTION RISK OF BREAKAGE!

It is not permitted to fix an adjusting block on the needle bar of the class 281. Doing so may damage the surface of the needle bar.

Standard checking

There are two types of needle bar for the class 281:

- Needle shank diameter 1.62 mm, needle system DB x1
- Needle shank diameter 2.0 mm, needle system 134

Should a setting of the needle bar height occur without using the gauge, use the following reference value: 0.8 mm distance between the hook point (lower edge) and the needle eye (upper edge).

Correction

- Remove the throat plate and the sewing foot.
- Place the gauge 4 on the surface of the throat plate.
- Fit the gauge 3 as far as it will go into the needle bar instead of a needle and fix it by tightening the fastening screw.
Gauge 0281 801819 Needle bar height for
needle diameter 1.62 mm
Gauge 0281 800300 Needle bar height for
needle diameter 2.00 mm
- Arrest the sewing machine at locking position "6".
- Loosen the screw 1.
- Push the needle bar 2 downwards.
The foot of the gauge 3 must rest on the gauge 4 without a gap.
- Fasten the screw 1 again.



ATTENTION !

The screw retaining the needle must point to the right (seen from the operator's side).

- Fix the throat plate and the sewing foot again.

6. Hook setting

6.1 Looping stroke and distance between the hook point and needle

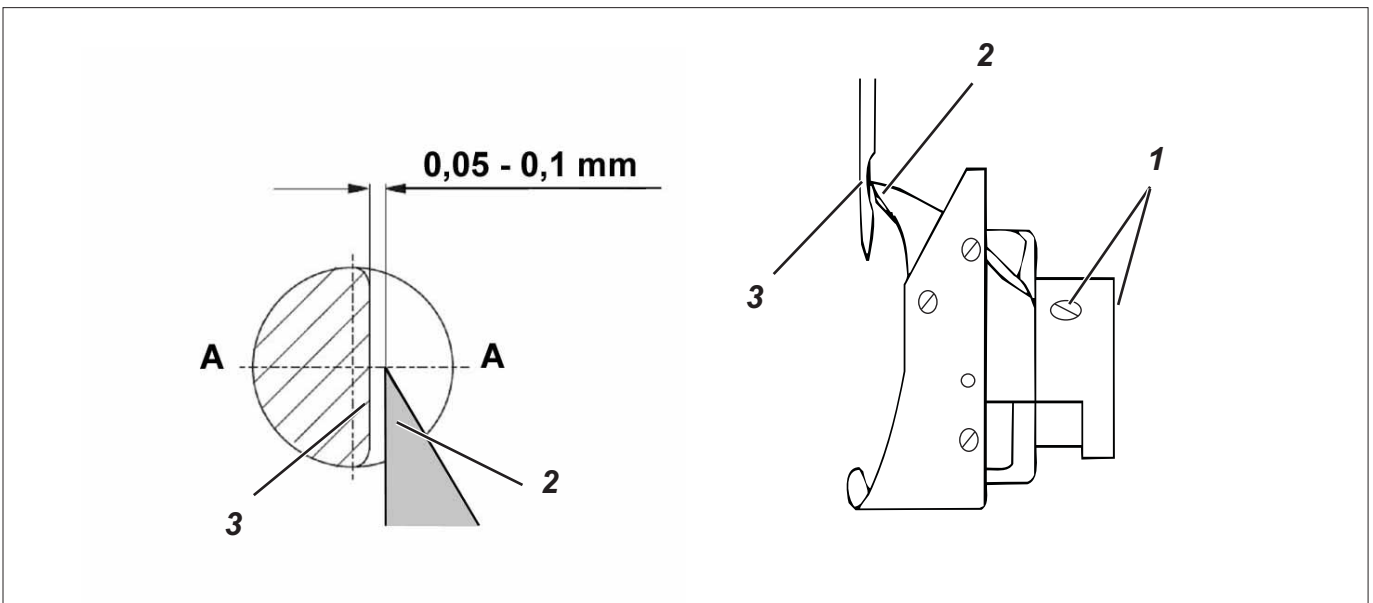

Caution: Risk of injury!

Turn off the main switch!

Check and set the looping stroke and the distance between the hook point and needle only with the sewing machine switched off.

GB

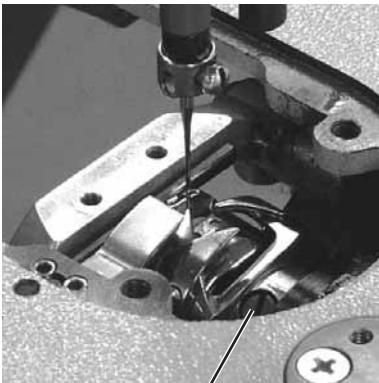

1



Standard checking

The loop stroke is the distance covered by the needle bar from the bottom dead center up to the point where the hook tip 2 coincides with the middle of the needle (line A-A).

The looping stroke amounts to 1.8 mm.

With the sewing machine arrested at locking position "1", the hook point 2 should be at the center of the needle.

The lateral distance between the hook point 2 and the needle scarf 3 should amount between 0.05 to 0.1 mm.

Correction

- Remove the sewing foot, the throat plate and the feed dog.
- Insert a new needle.
- Arrest the sewing machine at locking position "1".
- Loosen the fastening screw 1 of the hook.
- The distance between the hook point 2 and the needle scarf 2 should amount between 0.05 to 0.1 mm.
- Fasten the fastening screw 1 of the hook again.
- Fix the sewing foot, the throat plate and the feed dog again.

6.2 Bobbin case support

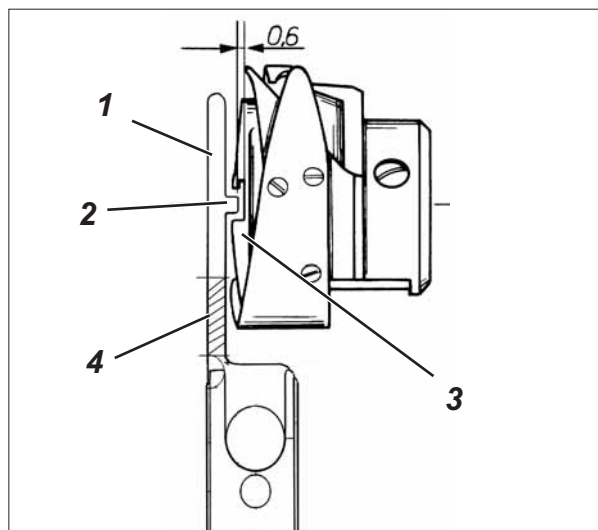
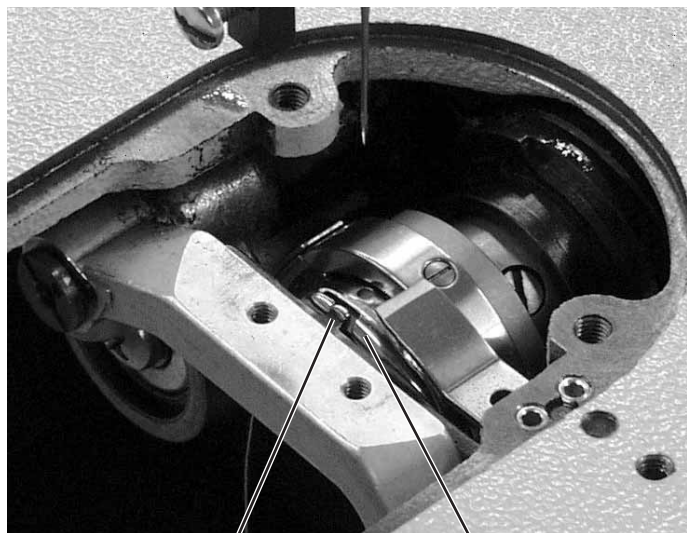

Caution: Risk of injury!

Turn off the main switch!

Check and set the bobbin case support only with the sewing machine switched off.

Standard checking

The bobbin case support is factory set.

After a replacement of the support, the new support may eventually need to be adjusted.



ATTENTION RISK OF BREAKAGE!

The adjustment can only be carried out within the hatched area 4. (see sketch)

Due to the extreme hardness within the area of the retaining tab 1, a risk of breakage is there.

Correction

- Remove the bobbin case support 1.
- Align the bobbin case support 1.
The distance between the retaining tab 2 of the bobbin case support and the lower part of the bobbin case 3 should be 0.6 mm.
- Mount the bobbin case support 1.

7. Thread trimmer

The control cam 3 determines the stroke and the timing of the knife motion. The timing thus coincides with the motion of the needle.
The thread trimmer is switched on electromagnetically.

7.1 Control cam for the knife motion

7.1.1 Control cam position

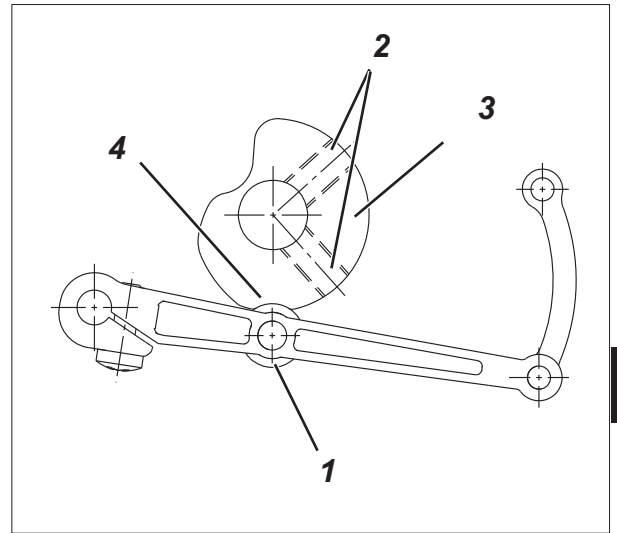
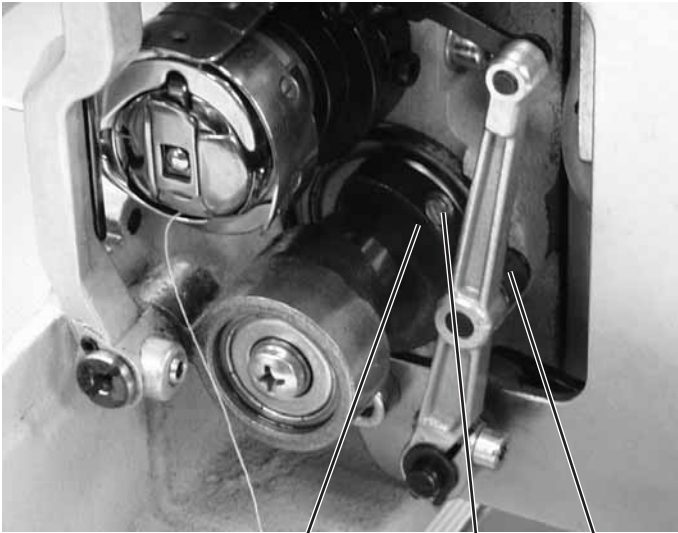

GB



Caution: Risk of injury!

Turn off the main switch!

Check and set the control cam only with the sewing machine switched off.

Standard checking

With the sewing machine arrested at locking position "4", the roller 1 must engage in the indentation 4 of the control cam 3 when manually pressed downwards.

Correction

- Arrest the sewing machine at locking position "4".
- Loosen the fastening screws 2 of the control cam 3.
- Turn the control cam of the lower shaft.
The roller 1 must engage in the indentation 4 of the control cam 3 when manually pressed downwards.
- Tighten the fastening screws 2 again.



7.1.2 Distance between the roller and thread trimmer cam

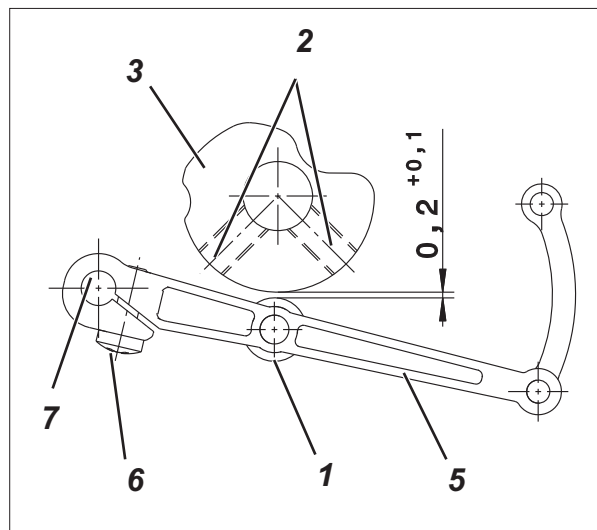
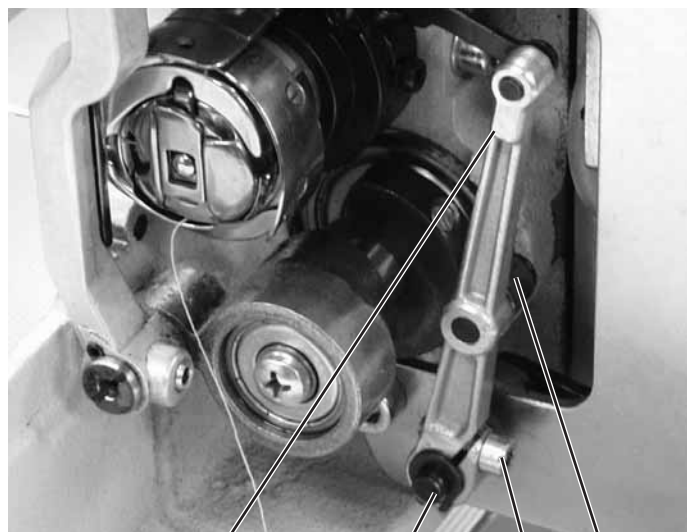

5 7 6 1



Caution: Risk of injury!

Turn off the main switch.

Check and set the control cam only with the sewing machine switched off.

Standard checking

At the external end position of the thread trimmer lever 5 there should be a distance of 0,2 + 0,1 mm between the external diameter of the control cam 3 and the roller 1.

It must be checked in a position of the cam between both fastening screws 2.

Correction

- Turn the handwheel until the roller 1 stands between both screws 2 of the thread trimmer control cam.
- Loosen the fastening screw 6.
- Turn the lever 5 on the shaft 7 so that the roller 1 has a distance of 0,2 + 0,1 mm to the external diameter of the control cam 3.
- Tighten the fastening screw 6.

Please note:

The following risks may be encountered if a greater clearance is set here:

- The thread cannot be caught
- The thread cannot be cut

7.2 Hooked knife

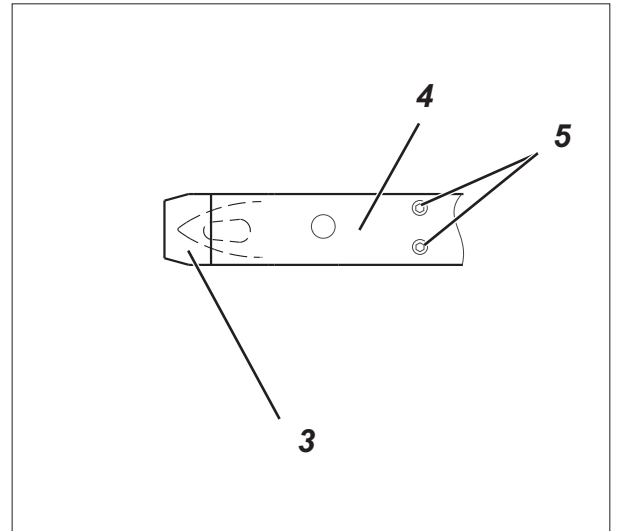
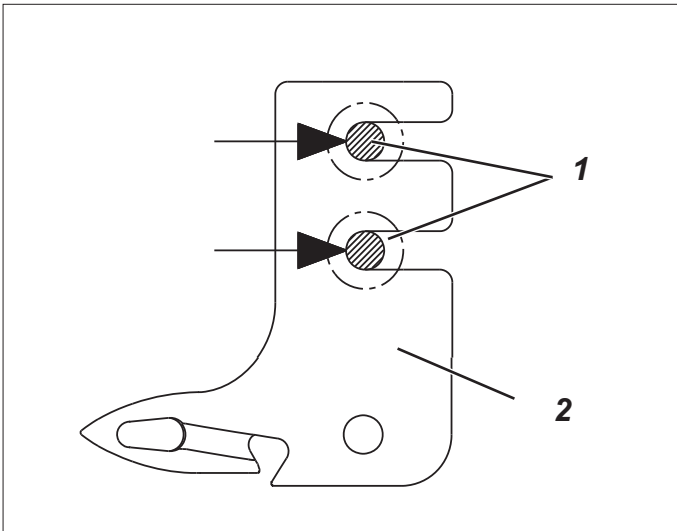

Caution: Risk of injury!

Turn off the main switch.

Check and set the hooked knife only with the sewing machine switched off.

GB

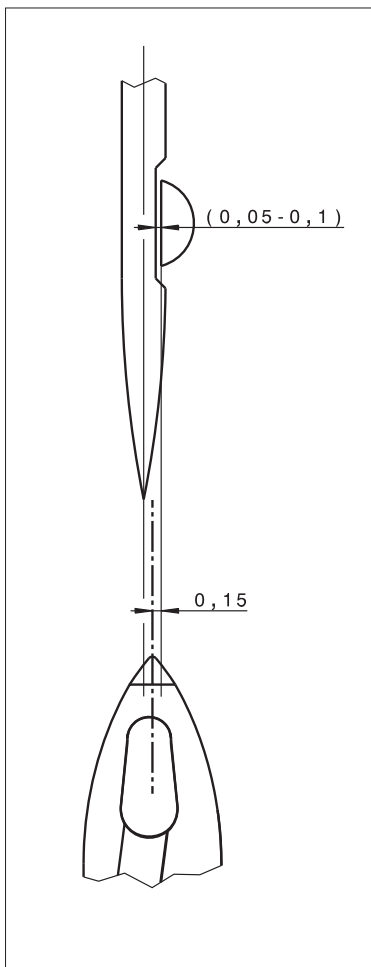

Standard checking

The hooked knife 2 must lie against both screws 1 in the direction of the arrow.

Hereby the cut through the tip of the hooked knife is ensured.

At the same time, the tip of the hooked knife has the correct position in the axial direction.

A virtual line lengthening the hooked knife point will then be in the center between the needle center and the hook tip.

Correction

- Unwind the clamping pressure of the fixed knife against the hooked knife through loosening the set screws 5.
- Manually swivel in the hooked knife 2.
- Loosen the fastening screws 1 of the hooked knife.
- Shift the hooked knife 2 against the fastening screws 1 in the direction of the arrow.
- Tighten the fastening screws 1 again.
- Check the eccentricity of the hooked knife.
- Set the counter knife (see chapter 7.3).

7.3 Setting the cutting pressure

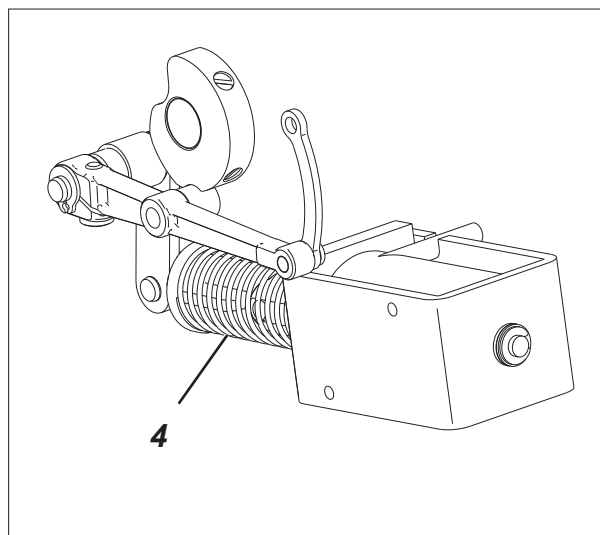
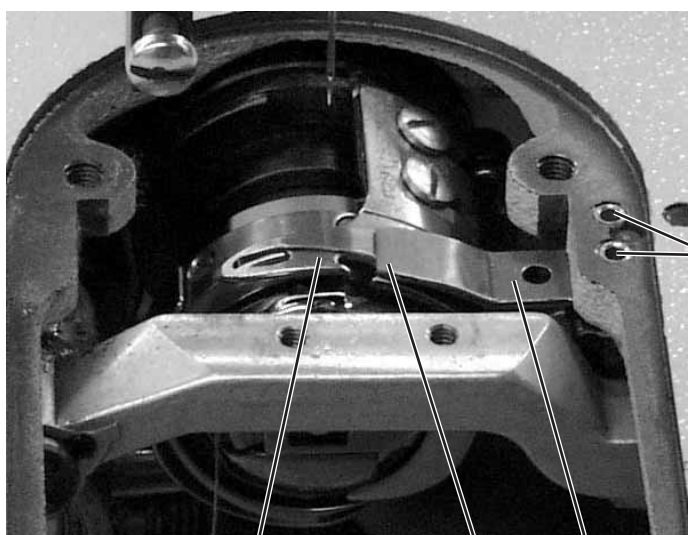

Caution: Risk of injury!

Turn off the main switch.

Check and set the cutting pressure only with the sewing machine switched off.

When performing setting tasks within the hook area, both knives should preferably remain in the machine. Thus avoiding unnecessary adjustment work.

Standard checking

The threads must reliably be cut with the lowest pressure possible. Low cutting pressure reduces the wear!

Two of the thickest threads to be sewn must reliably be cut simultaneously.

Correction

- Turn back the cutting pressure screws 1.
- Swivel forwards the hooked knife 3.
- Set the fixed knife 2 against the hooked knife 3 by screwing in the cutting pressure screws 1.
- Alternately lay the thread to be cut to the right and to the left.
- Adjust appropriate cutting pressure screw.
- If the return spring 4 does no longer bring the cutting mechanism to its starting position, then the cutting pressure is too high!
The fixed knife must be replaced against a new one.

Please note!

A regrinding of the fixed knife is allowed to a minor degree!
If the knife loses a lot of its length, it can no longer cut.
A new setting of the hooked knife **cannot** compensate it.

8. Setting the bobbin winder

8.1 Switching off the bobbin winder

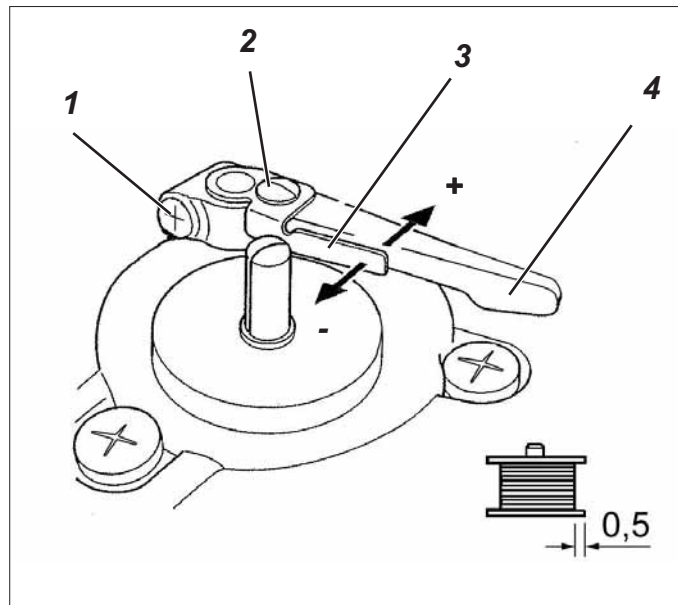

Caution: Risk of injury!

Turn the main switch off!

Check and set the bobbin winder only with the sewing machine switched off.

GB

Standard checking

The bobbin winder should stop automatically, when the bobbin is filled up to approx. 0.5 mm below the edge of the bobbin.

Correction

1. Minor changes of the bobbin wind-on quantity

- Bend the thread guide tab 3.

2. Major changes of the bobbin wind-on quantity

- Loosen the screw 2.
- Adjust the thread guide tab 3.
 - In the direction of the arrow - :
less quantity
 - In the direction of the arrow + :
more quantity
- Fasten the screw 2 again.

After a removal of the release lever 4, a pre-setting at the clamping screw 1 must be done first.



ATTENTION RISK OF BREAKAGE!

Lift the sewing foot with the hand lever and remove the bobbin case from the hook when winding without sewing.

8.2 Winding form of the bobbin

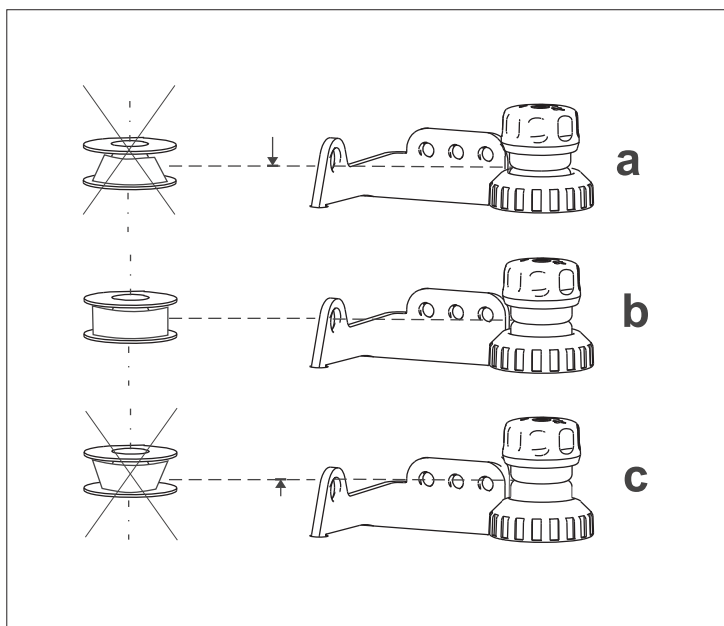
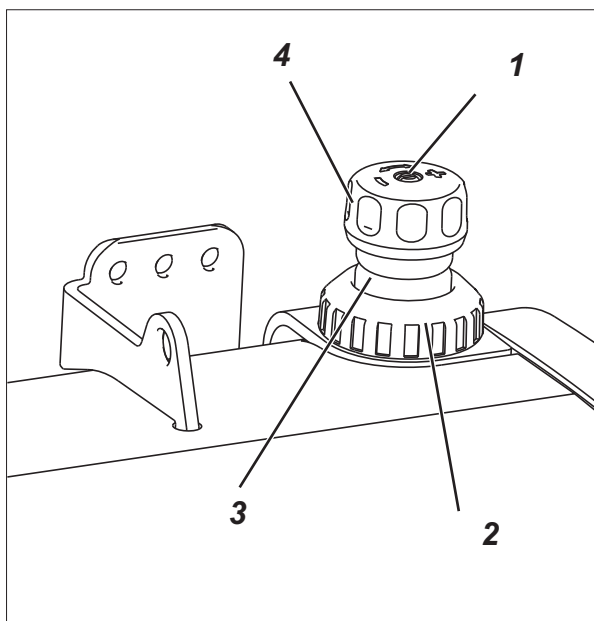

Caution: Risk of injury!

Turn the main switch off!

Check and set the bobbin winder only with the sewing machine switched off.

Standard checking

The winding form depends on the position of the gap 3 between both thread guide sleeves. It should be cylindrical in order to evenly fill the bobbin to its whole width.

- In the case a the gap is set too low.
- In the case c the gap is set too high.

Correction

- Loosen the knurled nut 2.
- Shift the guide bolt 1 axially through turning it with a screw driver. Make sure not to alter the position of the adjusting knob 4.
- Tighten the knurled nut 2 again.

8.3 Winding tightness

Standard checking

A minimum pretension of the bobbin thread is required in order to get a regular winding result (accurate winding on the bobbin). This depends on the sliding qualities and the thickness of the thread. A too strong tightness of the winding is favourable to the formation of ruffs.

Correction

- Turn the adjusting knob 4 clockwise = increase the pretension
- Turn the adjusting knob 4 counter-clockwise = decrease the pretension

9. Filling up oil (gear box)

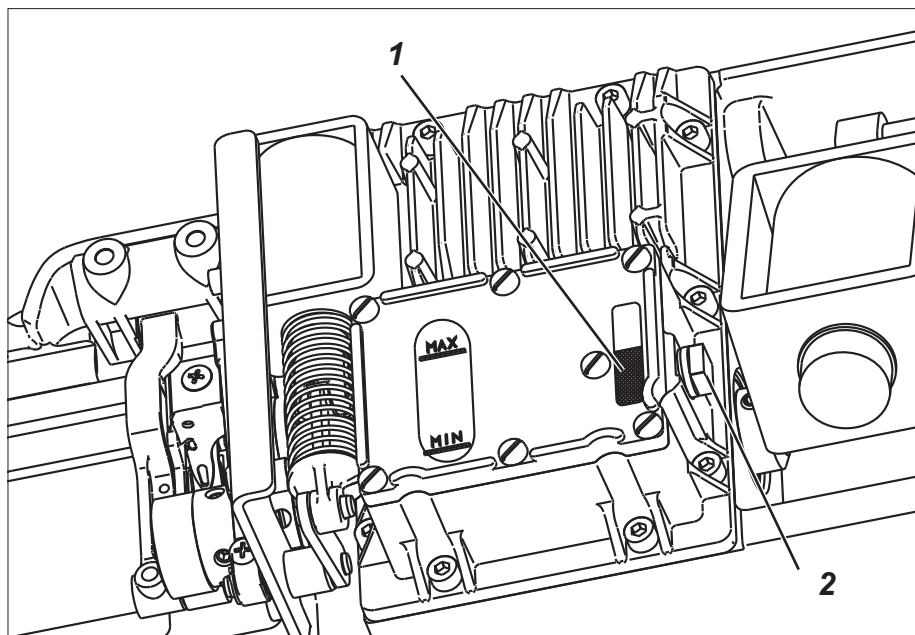

Caution: Risk of injury!

Oil can cause skin eruptions.

Avoid protracted contact with the skin.

In event of contact, thoroughly wash the affected area.



ATTENTION !

The handling and disposal of mineral oils is subject to legal regulation.

Deliver used oil to an authorised collection point.

Protect your environment.

Take care not to spill oil.

Rule

Check the oil level with the machine tilted to the back.

The machine head rest on the machine head support and the surface of the base plate is vertical to the table top.

The filling up check is intended for lifetime.

Upon delivery the oil level is in the middle of the monitor window 1.

Filling up oil (gear box)

- Tilt the machine backwards.
- Unscrew the plug screw 2 with its seal ring.
- Fill up with DA 32 oil up to the middle of the monitor window 1.

For this purpose use a hose connected to a oil can nozzle.

Oil grade being used

Special lubricating oil DA 32 / resistant to light and ageing resistant / high wear protection

Viscosity / 40°C: 32 mm²/s - ISO VG32

The oil can be obtained from Dürkopp Adler under the part number 9047 000032 in a 0.9l container.

10. Hook lubrication

(only subclasses with oil lubricated hook)

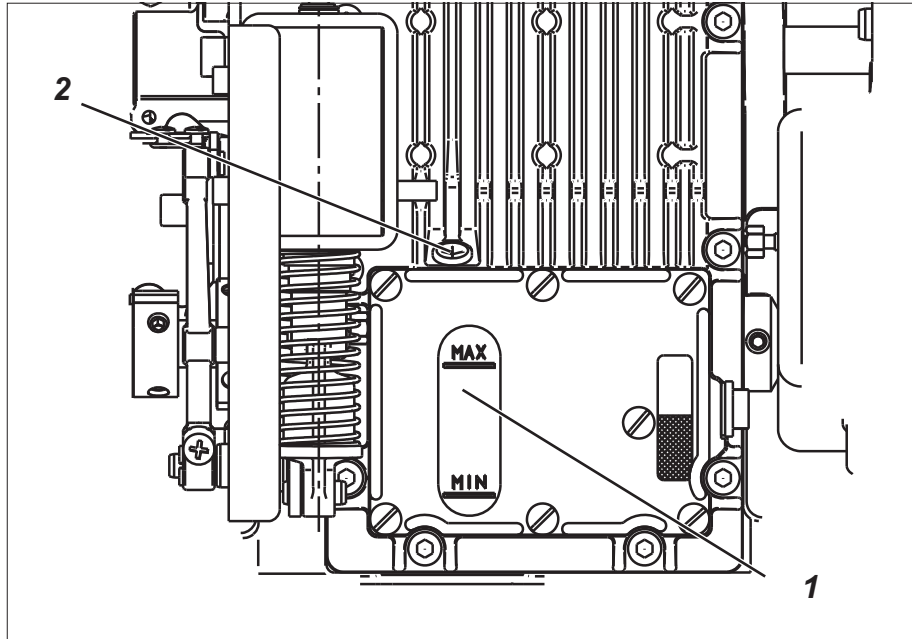

Caution: Risk of injury!

Oil can cause skin eruptions.
Avoid protracted contact with the skin.
In event of contact, thoroughly wash the affected area.



ATTENTION !

The handling and disposal of mineral oils is subject to legal regulation.
Deliver used oil to an authorised collection point.
Protect your environment.
Take care not to spill oil.

Maintenance work to be carried out	Explanation	Operating hours
Lubrication of the hook	The oil level shall not fall below the MIN level of the oil reservoir 1. Fill up the DA 10 oil through the bore hole 2 up to the marking line "Max".	8

Oil grade being used

Special lubricating oil DA 10 / colourless / resistant to light and ageing resistant / high wear and corrosion protection

Viscosity / 40°C: 10 mm²/s - ISO VG10

The oil can be obtained from Dürkopp Adler with the following parts numbers:

- 1 litre container 9047 000012
- 5 litre container 9047 000014

Please note !

In the machine equipped with an oil-free hook (subclass 281-140442) no oil filling up is necessary.

10.1 Setting the oil quantity for the hook

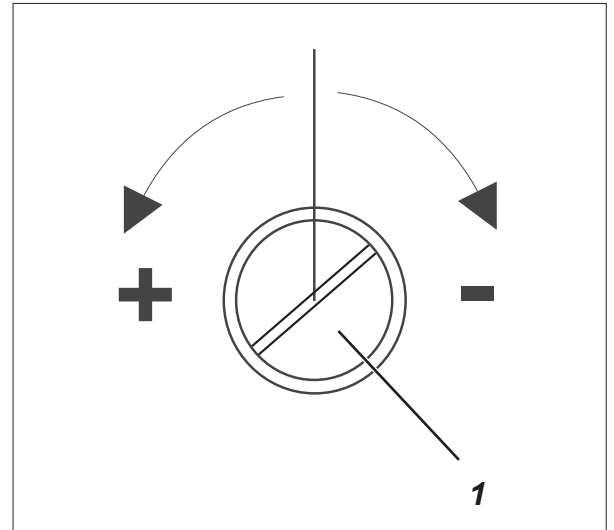
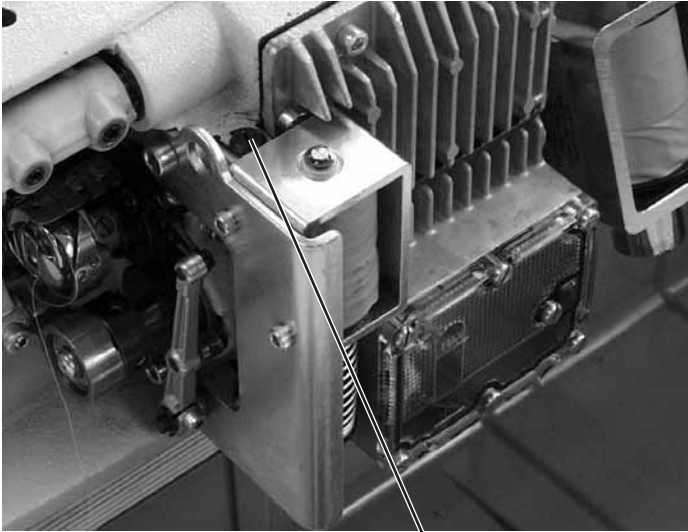

1

The hook lubrication is insured by the oil wick inside a silicone rubber hose, going from the hook oil reservoir to the spray cone on the back of the hook.

The oil quantity can be reduced through the adjustment screw 1. By pressing the hose, the adjustment screw throttles the oil quantity for the hook.

GB

Rule

Put a piece of paper instead of the throat plate above the throat plate cutout, and sew with the machine with the maximum speed for 15 sec. The paper should have a fine oil sprayed on it.

Correction

- Remove the throat plate.
- Remove the feed dog.
- Take out the bobbin case.
- Turn the adjustment screw 1.
Clockwise = less oil for the hook
Counter-clockwise = more oil for the hook
- Fix the throat plate, the feed dog and the bobbin case again.

Please note:

The reduction of the desired oil flow-rate does not happen instantly after the turning of the adjustment screw, this is because the residual oil in the wick between the throttle and the hook needs to be used up first.

A verification makes only sense if carried out a couple of hours later.

11. Maintenance



Caution: Risk of injury!

Turn the main switch off!
The maintenance of the sewing machine must only be done when the machine is switched off.

The daily or weekly maintenance work (cleaning and oiling) to be carried out by the operators of the sewing machine is described in the operating instructions (part 1). It is only listed in the following table for the sake of completeness.

Maintenance work to be carried out	Operating hours			
	8	40	160	500
Sewing machine head				
- Remove dust in the area under the throat plate	X			
- Remove dust from between the feed dog elements	X			
(remove the throat plate)				
- Remove dust in the area under the bobbin brake spring	X			
- Check oil level		X		
- Check oil level in oil reservoir for the hook lubrication		X		
- Check hook lubrication			X	
- Check toothed belt				X
Sewing motor				
- Clean the motor aerator filter		X		

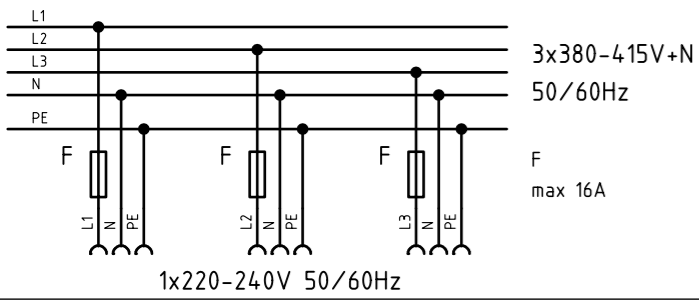

Terminal to three-phase power supplies:
Anschluß an Drehstromnetze:
3x380-415V+N
50/60Hz
F max 16A

Several dc-drives must be distributed evenly among all phases.
Mehrere DC-Antriebe sind gleichmäßig auf alle Phasen zu verteilen.

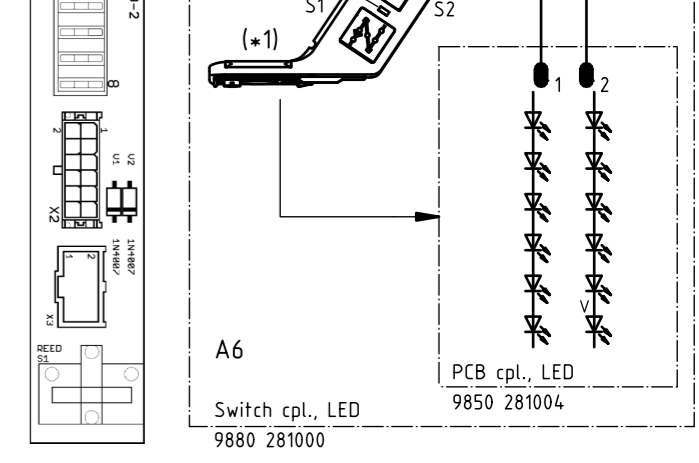
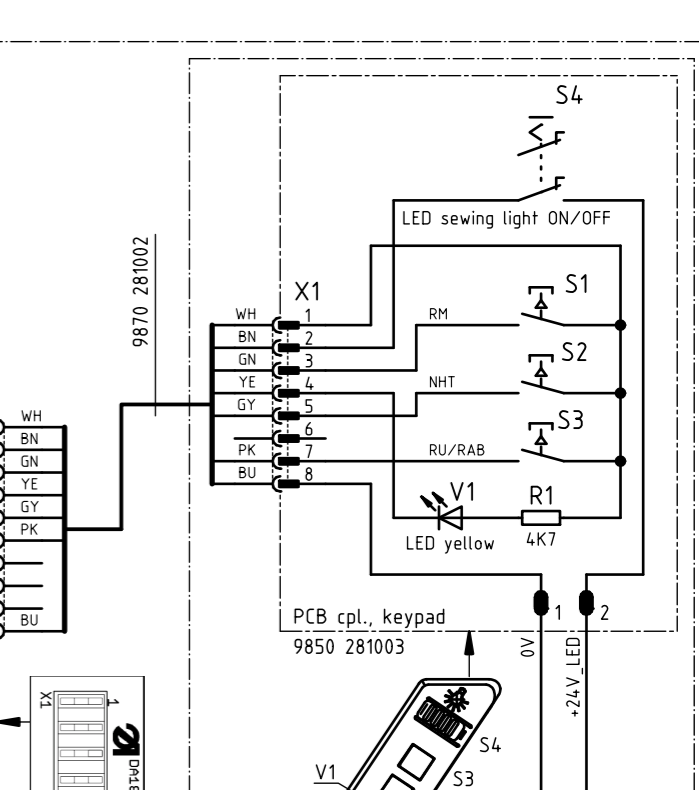
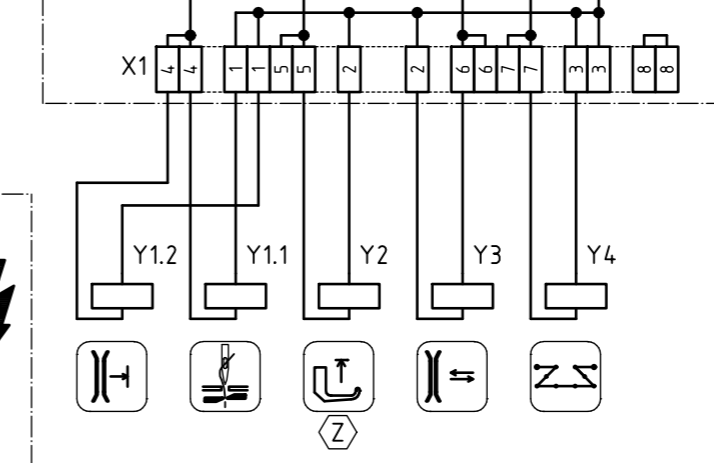
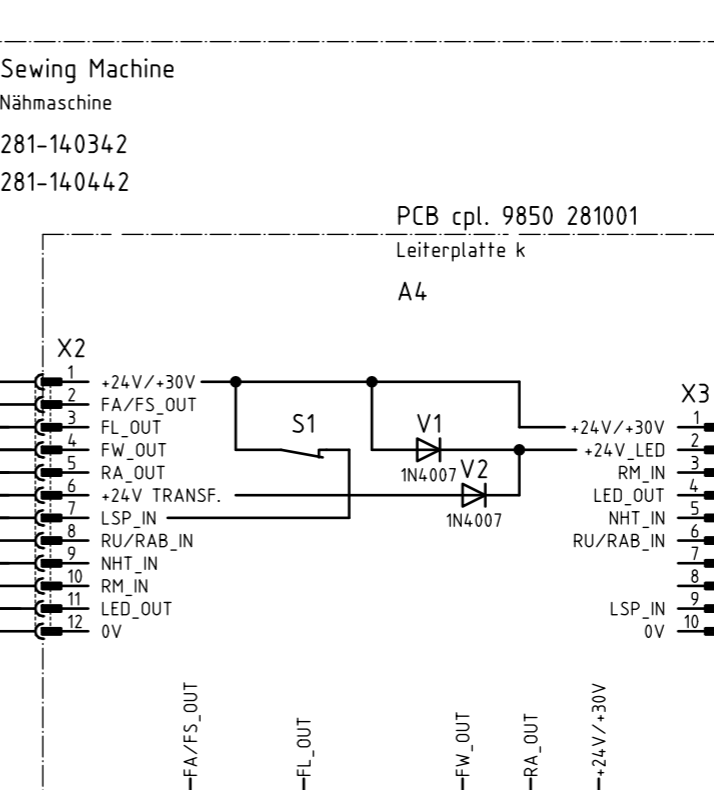
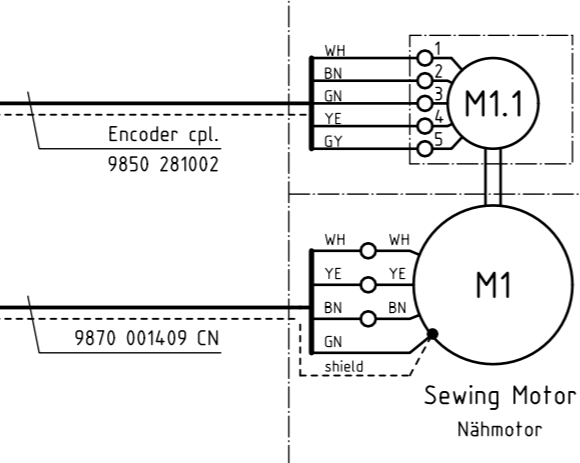
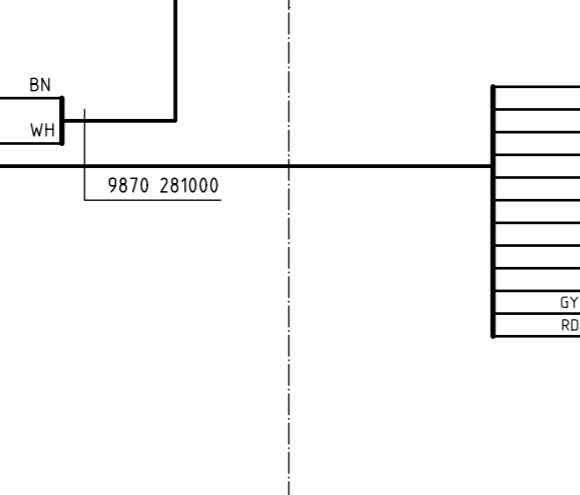
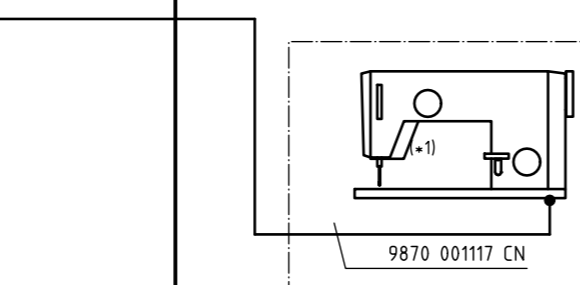
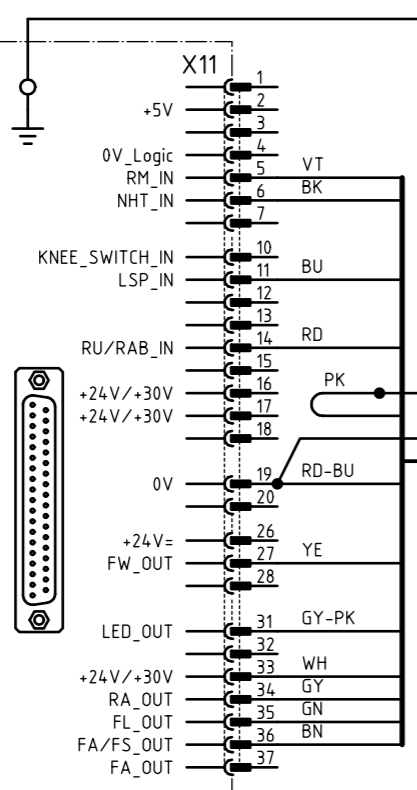
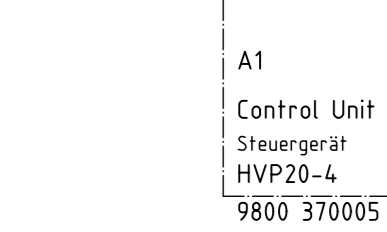
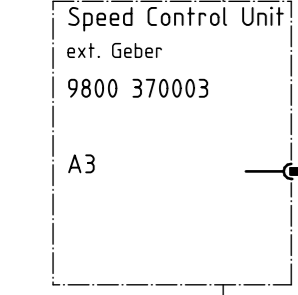
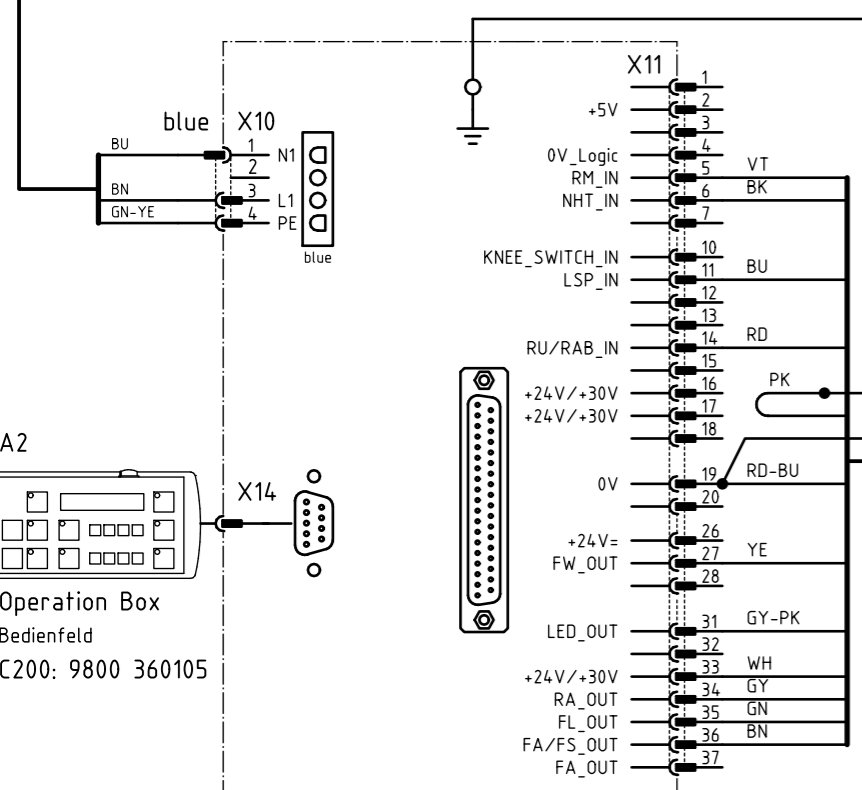
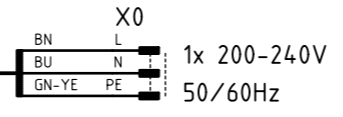
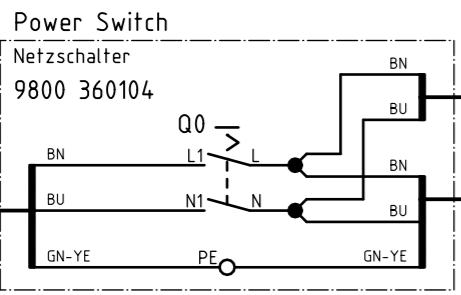
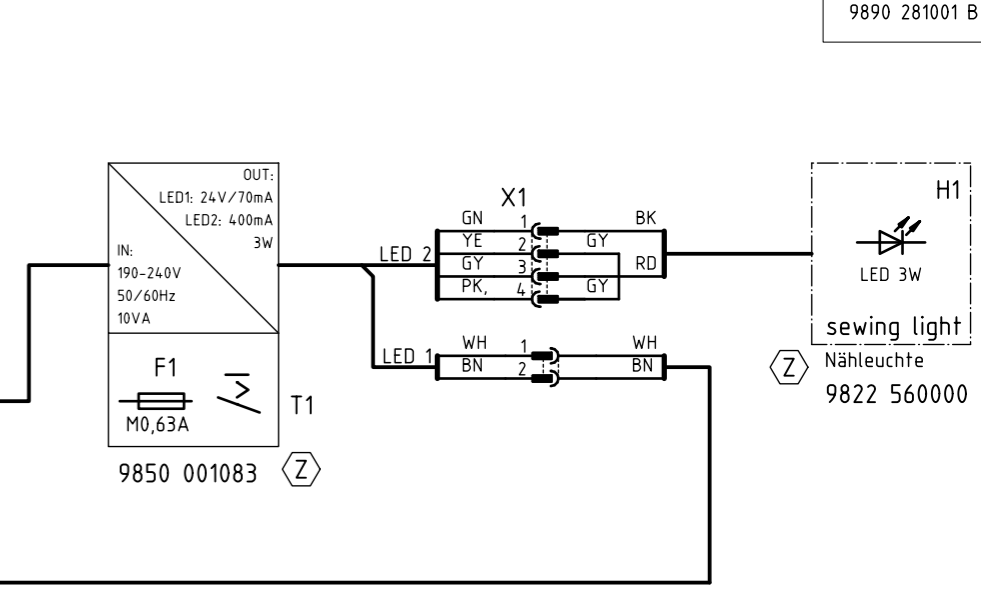
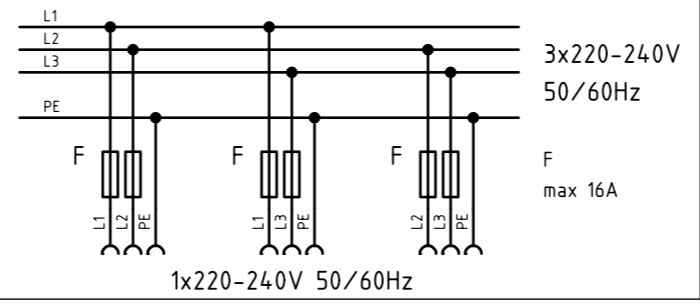

(Z) = Optional Equipment
Sonderausstattung

d			
c			
b			
a			
No.	Date	Signature	Confirmation
Modifications/			

drawing valid from April 2009

DÜRKOPP ADLER AG Bielefeld
www.duerkopp-adler.com

Date/ 2008-09-08
Designer/ Czytrich
Checker/ Priemer
Release/ 0145/05

Cl. 281-140342; -140442
Control Unit HVP-20-4-28-CE
triple keypad with LED-sewinglight

Denomination	connection diagram	Page
Part Number/	9890 281001 B	1/2

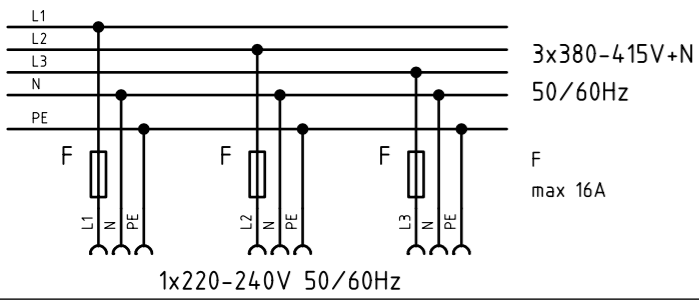

Several dc-drives must be distributed evenly among all phases.
Mehrere DC-Antriebe sind gleichmäßig auf alle Phasen zu verteilen.

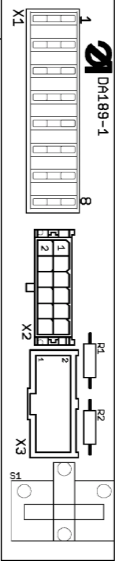
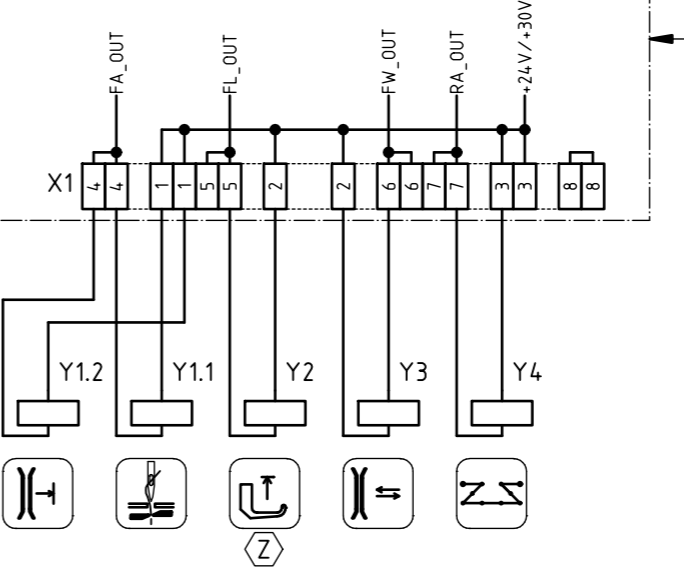
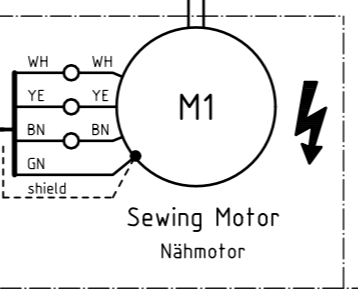
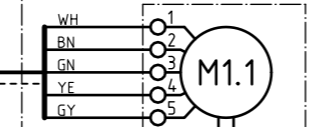
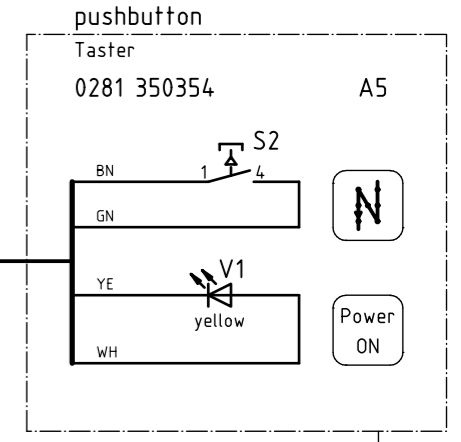
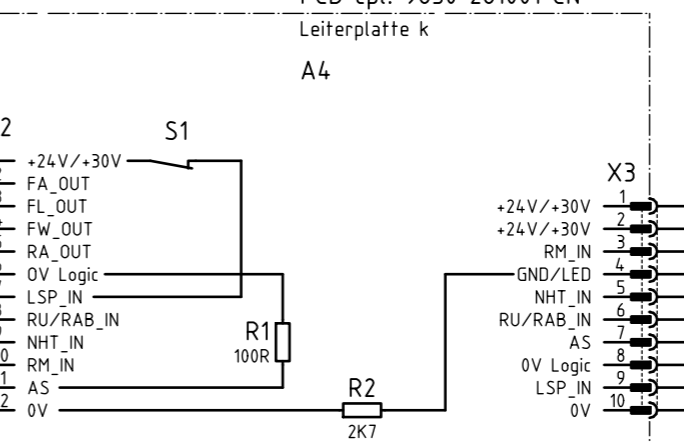
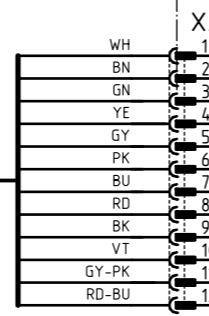
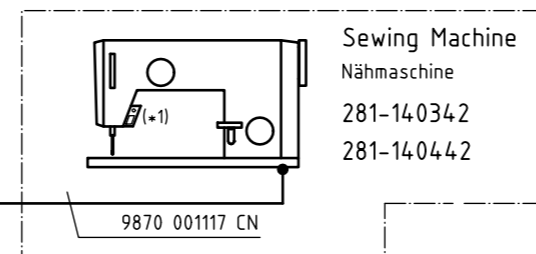
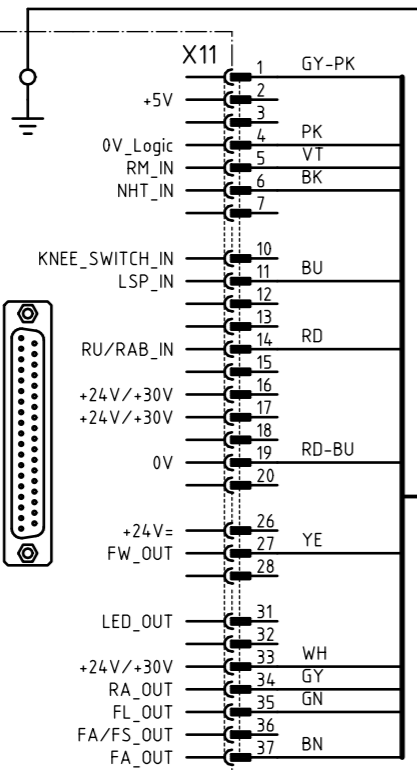
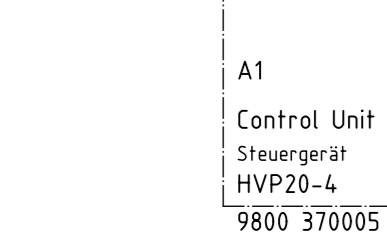
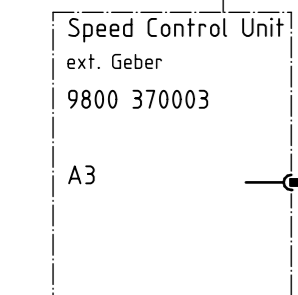
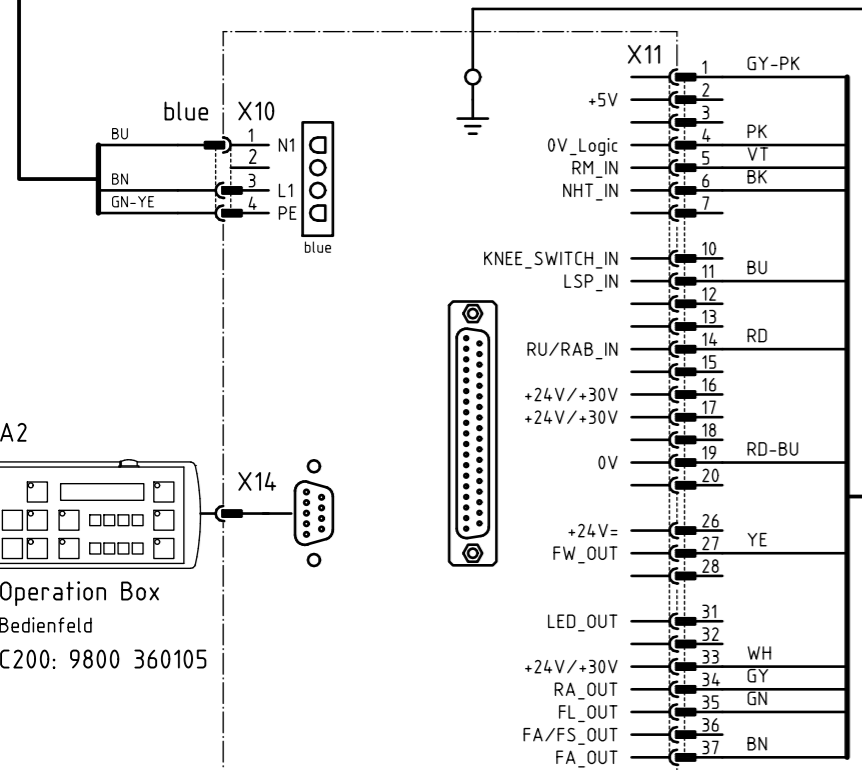
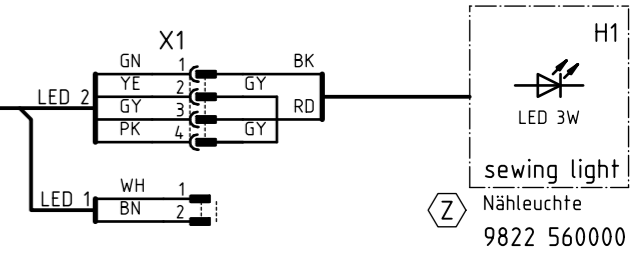
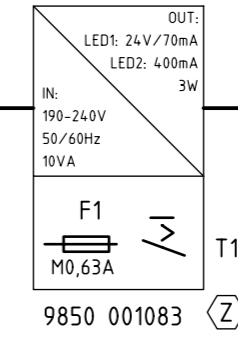
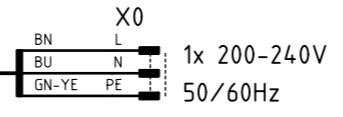
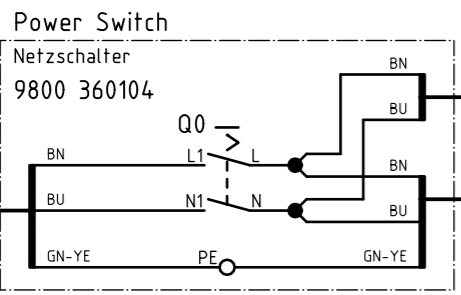
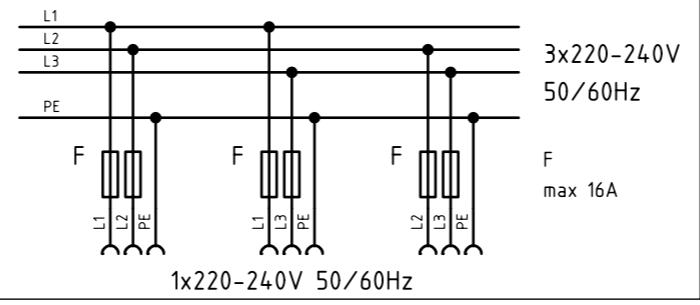

(Z) = Optional Equipment
Sonderausstattung

drawing valid to March 2009				Denomination		connection diagram	
DÜRKOPP ADLER AG Bielefeld				Date/	2008-09-08	Page	
www.duerkopp-adler.com				Designer/	Czytrich	Part Number/	
Modifications/				Checker/	Priemer	9890 281001 B	
				Release/	0145 / 05	2/2	
				Cl. 281-140342; -140442			
				Control Unit HVP-20-4-28-CE and single pushbutton			