

ShaftWall

Shaft and duct encasement system



All our systems are covered by SpecSure® when using genuine Gyproc and Isover products



ShaftWall

ShaftWall provides a lightweight, fire resistant structure to protect elements in confined spaces wherever access is limited to one side only.

The system provides a protective structure which can be incorporated at an early stage of the construction without the need for scaffolding.

The system can also be built horizontally to provide a fire rated membrane.

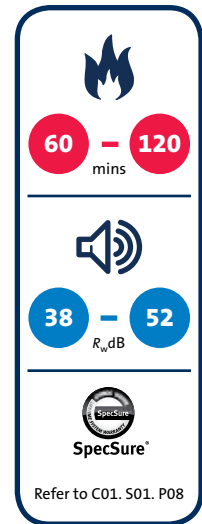

Key benefits

- Horizontal membranes are built entirely from below
- A ShaftWall variant with non-combustible Glasroc F FIRECASE board linings is available
- High level commonality with GypWall partition components, particularly 70mm stud solutions
- Higher certainty of installed acoustic performance due to laboratory tests incorporating deflection heads
- Can be used where access is limited to one side at the head, e.g. M & E cages already installed in corridors

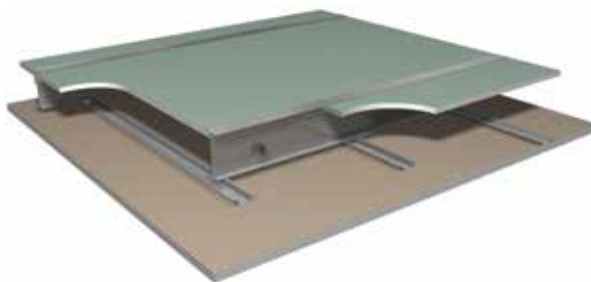

You may also be interested in...

For assistance in choosing the right solution for your project, try our **System Selector**; an online tool that enables quick and easy filtering by performance criteria. It provides system specific downloads including:

- BIM (Revit) objects
- Specification Clauses
- System and product data sheets

► Refer to gyproc.ie



Table 1a — Solutions to satisfy the requirements of BS EN 1364-1: 1999

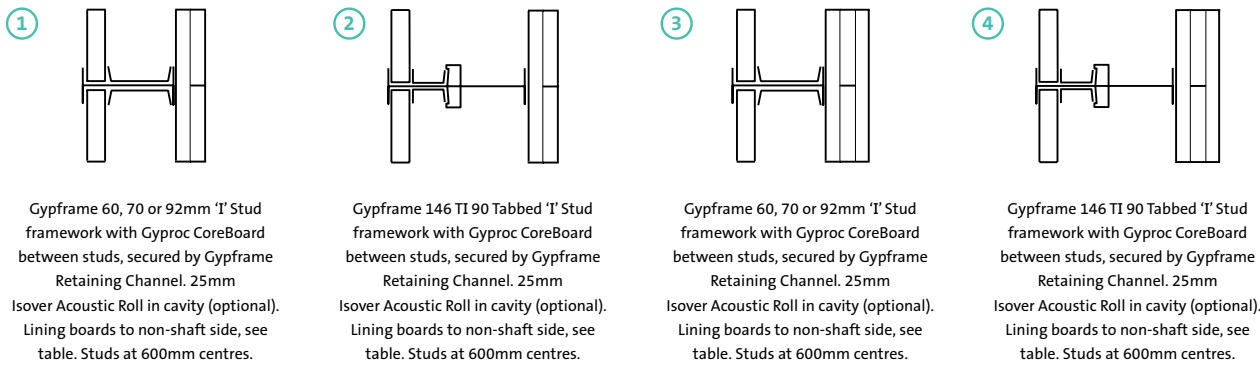

| Detail | Partition thickness mm | Lining boards to non-shaft side ¹ | | Max. partition height ² mm | Stud size mm | Sound insulation R_w dB ³ | | Duty rating ⁵ | Approx. weight kg/m ² | System reference |
|------------------------------------|------------------------|--|---------------------|---------------------------------------|--------------|--|--|--------------------------|----------------------------------|------------------|
| | | Board type | Lining thickness mm | | | No insulation | Sealed structure plus 25mm Isover Acoustic Roll ⁴ | | | |
| 60 minutes fire resistance | | | | | | | | | | |
| ① | 87 | Gyproc FireLine | 2 x 12.5 | 4400 | 60 | 40 | 44 | Severe | 39 | A306002/012 |
| ① | 97 | Gyproc FireLine | 2 x 12.5 | 4400 | 70 | 40 | 44 | Severe | 39 | A306002/012 |
| ① | 119 | Gyproc FireLine | 2 x 12.5 | 6000 | 92 | 45 | 47 | Severe | 40 | A306005/014 |
| ② | 173 | Gyproc FireLine | 2 x 12.5 | 6000 | 146 | 48 | 52 | Severe | 42 | A306008/020 |
| 90 minutes fire resistance | | | | | | | | | | |
| ① | 92 | Gyproc FireLine | 2 x 15 | 4500 | 60 | 42 | 45 | Severe | 43 | A306003/023 |
| ① | 102 | Gyproc FireLine | 2 x 15 | 4500 | 70 | 42 | 45 | Severe | 43 | A306003/023 |
| ① | 124 | Gyproc FireLine | 2 x 15 | 6000 | 92 | 44 | 46 | Severe | 44 | A306006/025 |
| ② | 178 | Gyproc FireLine | 2 x 15 | 6000 | 146 | 48 | 50 | Severe | 46 | A306009/028 |
| 120 minutes fire resistance | | | | | | | | | | |
| ③ | 107 | Gyproc FireLine | 3 x 15 | 4500 | 60 | 43 | 45 | Severe | 55 | A306030/035 |
| ③ | 117 | Gyproc FireLine | 3 x 15 | 4500 | 70 | 43 | 45 | Severe | 55 | A306030/035 |
| ③ | 139 | Gyproc FireLine | 3 x 15 | 6000 | 92 | 45 | 46 | Severe | 56 | A306031/036 |
| ④ | 193 | Gyproc FireLine | 3 x 15 | 6000 | 146 | 49 | 50 | Severe | 58 | A306032/033 |

▶ For further assistance in choosing the right solution for your project, try our System Selector; an online tool that enables quick and easy filtering by performance criteria. It provides system specific information downloads including BIM (Revit) objects. Go to gyproc.ie

¹ For improved durability and impact resistance, the outer layer of Gyproc FireLine can be replaced with a layer of 15mm Gyproc DuraLine.
² The maximum heights quoted are limited by the fire state field of application or by limiting deflection of L/240 at 200 Pa, whichever is the more onerous.
³ The acoustic performance figures quoted include ShaftWall partitions with deflection heads.
⁴ Gyproc CoreBoard and first layer of lining board are bedded onto Gyproc Sealant, as required for pressurised air shafts, in addition to normal sealing.
⁵ Estimated rating from non-shaft side only.

NB The fire resistance and sound insulation performances are for imperforate partitions, but incorporating deflection heads, with all joints taped and filled, or skimmed according to Gyproc's recommendations. The quoted performances are achieved only if Gyproc and Isover components are used throughout, and the Company's fixing recommendations are strictly observed. Any variation in the specifications should be checked with Gyproc.

NB Gypframe Extra Deep Flange Floor & Ceiling Channel or Gypframe 'J' Channel should be used at the head. For the base Gypframe Folded Edge Standard Floor & Ceiling Channel should be used for heights up to 4200mm, Gypframe Deep Flange Floor & Ceiling Channel should be used for heights between 4200mm and 8000mm, Gypframe Extra Deep Flange Floor & Ceiling Channel should be used for heights in excess of 8000mm.

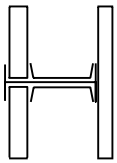
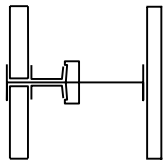
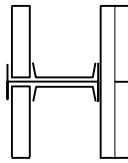
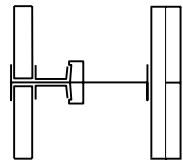

Table 1b — Solutions to satisfy requirements of BS 476: Part 22: 1987

| | | | |
|--|--|---|--|
| <p>①</p>  | <p>②</p>  | <p>③</p>  | <p>④</p>  |
|--|--|---|--|

| Detail | Partition thickness mm | Lining boards to non-shaft side ¹ | | Max. partition height ² mm | Stud size mm | Sound insulation R_w dB ³ | | Duty rating ⁵ | Approx. weight kg/m ² | System reference |
|---|------------------------|--|---------------------|---------------------------------------|--------------|--|--|--------------------------|----------------------------------|------------------|
| | | Board type | Lining thickness mm | | | No insulation | Sealed structure plus 25mm Isover Acoustic Roll ⁴ | | | |
| (60)/30 minutes fire resistance (BS) (exposure to fire from shaft side) | | | | | | | | | | |
| ① | 77 | Gyproc FireLine | 1 x 15 | 4200 | 60 | 39 | 42 | Heavy | 30 | A306001/010 |
| ① | 87 | Gyproc FireLine | 1 x 15 | 4200 | 70 | 39 | 42 | Heavy | 30 | A306001/010 |
| ① | 109 | Gyproc FireLine | 1 x 15 | 6000 | 92 | 40 | 43 | Heavy | 31 | A306004/011 |
| ② | 163 | Gyproc FireLine | 1 x 15 | 7700 | 146 | 43 | 46 | Heavy | 33 | A306007/013 |
| (90)/60 minutes fire resistance (BS) (exposure to fire from shaft side) | | | | | | | | | | |
| ① | 87 | Gyproc FireLine | 2 x 12.5 | 4400 | 60 | 40 | 44 | Severe | 39 | A306002/012 |
| ① | 97 | Gyproc FireLine | 2 x 12.5 | 4400 | 70 | 40 | 44 | Severe | 39 | A306002/012 |
| ① | 119 | Gyproc FireLine | 2 x 12.5 | 6400 | 92 | 45 | 47 | Severe | 40 | A306005/014 |
| ② | 173 | Gyproc FireLine | 2 x 12.5 | 7900 | 146 | 48 | 52 | Severe | 42 | A306008/020 |
| (120)/90 minutes fire resistance (BS) (exposure to fire from shaft side) | | | | | | | | | | |
| ③ | 92 | Gyproc FireLine | 2 x 15 | 4500 | 60 | 42 | 45 | Severe | 43 | A306003/023 |
| ③ | 102 | Gyproc FireLine | 2 x 15 | 4500 | 70 | 42 | 45 | Severe | 43 | A306003/023 |
| ③ | 124 | Gyproc FireLine | 2 x 15 | 6700 | 92 | 44 | 46 | Severe | 44 | A306006/025 |
| ④ | 178 | Gyproc FireLine | 2 x 15 | 7900 | 146 | 48 | 50 | Severe | 46 | A306009/028 |

▶ For further assistance in choosing the right solution for your project, try our System Selector; an online tool that enables quick and easy filtering by performance criteria. It provides system specific information downloads including BIM (Revit) objects. Go to Gyproc.ie

¹ For improved durability and impact resistance, the outer layer of Gyproc FireLine can be replaced with a layer of 15mm Gyproc DuraLine.

² Based on limiting deflection of L/240 at 200 Pa.

³ The acoustic performance figures quoted include ShaftWall partitions with deflection heads.

⁴ Gyproc CoreBoard and first layer of lining board are bedded onto Gyproc Sealant, as required for pressurised air shafts, in addition to normal sealing.

⁵ Estimated rating from non-shaft side only.

(NB) The fire resistance and sound insulation performances are for imperforate partitions, but incorporating deflection heads, with all joints taped and filled, or skimmed according to Gyproc's recommendations. The quoted performances are achieved only if Gyproc and Isover components are used throughout, and the Company's fixing recommendations are strictly observed. Any variation in the specifications should be checked with Gyproc.

(NB) Gyppframe Extra Deep Flange Floor & Ceiling Channel or Gyppframe 'J' Channel should be used at the head. For the base Gyppframe Folded Edge Standard Floor & Ceiling Channel should be used for heights up to 4200mm, Gyppframe Deep Flange Floor & Ceiling Channel should be used for heights between 4200mm and 8000mm, Gyppframe Extra Deep Flange Floor & Ceiling Channel should be used for heights in excess of 8000mm.

ShaftWall performance (continued)

Vertical elements — non-combustible board linings

For details of when to specify fire resistance using EN
► Refer to C02. S01. P18



Table 2a — Solutions to satisfy the requirements of BS EN 1364-1: 1999

| 1 | 2 | 3 | 4 |
|---|---|---|---|
| | | | |

| Detail | Partition thickness mm | Lining boards to non-shaft side ¹ | | Max. partition height ² mm | Stud size mm | Sound insulation R_w dB ³ | | Duty rating ⁵ | Approx. weight kg/m ² | System reference |
|------------------------------------|------------------------|--|---------------------|---------------------------------------|--------------|--|--|--------------------------|----------------------------------|------------------|
| | | Board type | Lining thickness mm | | | No insulation | Sealed structure plus 25mm Isover Acoustic Roll ⁴ | | | |
| 60 minutes fire resistance | | | | | | | | | | |
| 1 | 92 | Glasroc F FIRECASE | 2 x 15 | 4500 | 60 | 41 | 44 | Severe | 46 | G306003/023 |
| 1 | 102 | Glasroc F FIRECASE | 2 x 15 | 4500 | 70 | 41 | 44 | Severe | 46 | G306003/023 |
| 1 | 124 | Glasroc F FIRECASE | 2 x 15 | 6000 | 92 | 43 | 45 | Severe | 47 | G306006/025 |
| 2 | 178 | Glasroc F FIRECASE | 2 x 15 | 6000 | 146 | 47 | 49 | Severe | 49 | G306009/028 |
| 90 minutes fire resistance | | | | | | | | | | |
| 1 | 92 | Glasroc F FIRECASE | 2 x 15 | 4500 | 60 | 41 | 44 | Severe | 46 | G306003/023 |
| 1 | 102 | Glasroc F FIRECASE | 2 x 15 | 4500 | 70 | 41 | 44 | Severe | 46 | G306003/023 |
| 1 | 124 | Glasroc F FIRECASE | 2 x 15 | 6000 | 92 | 43 | 45 | Severe | 47 | G306006/025 |
| 2 | 178 | Glasroc F FIRECASE | 2 x 15 | 6000 | 146 | 47 | 49 | Severe | 49 | G306009/028 |
| 120 minutes fire resistance | | | | | | | | | | |
| 3 | 107 | Glasroc F FIRECASE | 3 x 15 | 4500 | 60 | 42 | 44 | Severe | 59 | G306030/035 |
| 3 | 117 | Glasroc F FIRECASE | 3 x 15 | 4500 | 70 | 42 | 44 | Severe | 59 | G306030/035 |
| 3 | 139 | Glasroc F FIRECASE | 3 x 15 | 6000 | 92 | 44 | 45 | Severe | 60 | G306031/036 |
| 4 | 193 | Glasroc F FIRECASE | 3 x 15 | 6000 | 146 | 48 | 49 | Severe | 62 | G306032/033 |

► For further assistance in choosing the right solution for your project, try our System Selector; an online tool that enables quick and easy filtering by performance criteria. It provides system specific information downloads including BIM (Revit) objects. Go to gyproc.ie

¹ For a non-combustible solution on the shaft side use only the Glasroc F FIRECASE. On the non-shaft side this can be replaced with a layer of 15mm Gyproc FireLine or Gyproc DuraLine.

² The maximum heights quoted are limited by the fire state field of application or by limiting deflection of L/240 at 200 Pa, whichever is the more onerous.

³ The acoustic performance figures quoted include ShaftWall partitions with deflection heads.

⁴ 20mm Glasroc F FIRECASE and first layer of lining board are bedded onto Gyproc Sealant, as required for pressurised air shafts, in addition to normal sealing.

⁵ Estimated rating from non-shaft side only.

NB The fire resistance and sound insulation performances are for imperforate partitions, but incorporating deflection heads, with all joints taped and filled, or skimmed according to Gyproc's recommendations. The quoted performances are achieved only if Gyproc and Isover components are used throughout, and the Company's fixing recommendations are strictly observed. Any variation in the specifications should be checked with Gyproc.

NB Gypframe Extra Deep Flange Floor & Ceiling Channel or Gypframe 'J' Channel should be used at the head. For the base Gypframe Folded Edge Standard Floor & Ceiling Channel should be used for heights up to 4200mm, Gypframe Deep Flange Floor & Ceiling Channel should be used for heights between 4200mm and 8000mm, Gypframe Extra Deep Flange Floor & Ceiling Channel should be used for heights in excess of 8000mm.



Table 2b — Solutions to satisfy requirements of BS 476: Part 22: 1987

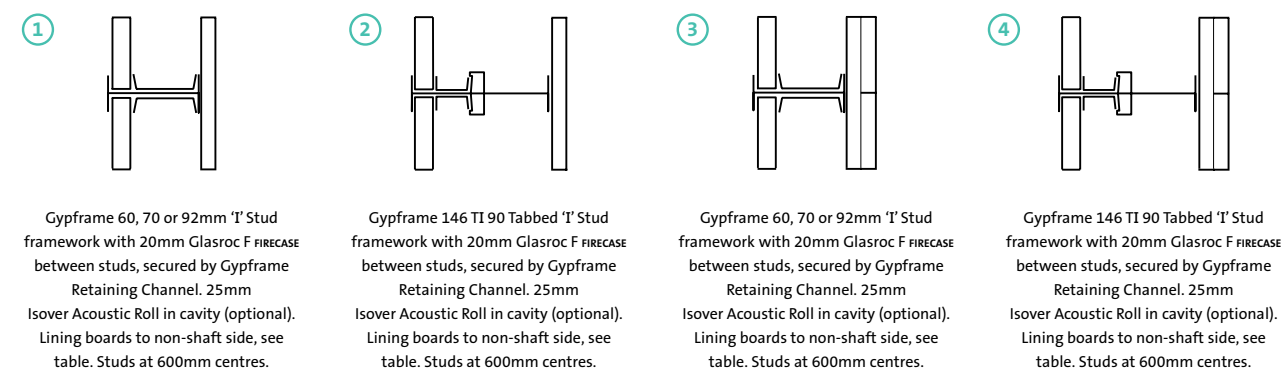

| Detail | Partition thickness mm | Lining boards to non-shaft side ¹ | | Max. partition height ² mm | Stud size mm | Sound insulation R_w dB ³ | | Duty rating ⁵ | Approx. weight kg/m ² | System reference |
|---|------------------------|--|---------------------|---------------------------------------|--------------|--|--|--------------------------|----------------------------------|------------------|
| | | Board type | Lining thickness mm | | | No insulation | Sealed structure plus 25mm Isover Acoustic Roll ⁴ | | | |
| (60)/30 minutes fire resistance (BS) (exposure to fire from shaft side) | | | | | | | | | | |
| ① | 77 | Glasroc F FIRECASE | 1 x 15 | 4200 | 60 | 38 | 41 | Heavy | 32 | G306001/010 |
| ① | 87 | Glasroc F FIRECASE | 1 x 15 | 4200 | 70 | 38 | 41 | Heavy | 32 | G306001/010 |
| ① | 109 | Glasroc F FIRECASE | 1 x 15 | 6000 | 92 | 39 | 42 | Heavy | 33 | G306004/011 |
| ② | 163 | Glasroc F FIRECASE | 1 x 15 | 7700 | 146 | 42 | 45 | Heavy | 35 | G306007/013 |
| (90)/60 minutes fire resistance (BS) (exposure to fire from shaft side) | | | | | | | | | | |
| ① | 92 | Glasroc F FIRECASE | 2 x 15 | 4500 | 60 | 41 | 44 | Severe | 46 | G306003/023 |
| ① | 102 | Glasroc F FIRECASE | 2 x 15 | 4500 | 70 | 41 | 44 | Severe | 46 | G306003/023 |
| ① | 124 | Glasroc F FIRECASE | 2 x 15 | 6400 | 92 | 43 | 45 | Severe | 47 | G306006/025 |
| ② | 178 | Glasroc F FIRECASE | 2 x 15 | 7900 | 146 | 47 | 49 | Severe | 49 | G306009/028 |
| (120)/90 minutes fire resistance (BS) (exposure to fire from shaft side) | | | | | | | | | | |
| ③ | 92 | Glasroc F FIRECASE | 2 x 15 | 4500 | 60 | 41 | 44 | Severe | 46 | G306003/023 |
| ③ | 102 | Glasroc F FIRECASE | 2 x 15 | 4500 | 70 | 41 | 44 | Severe | 46 | G306003/023 |
| ③ | 124 | Glasroc F FIRECASE | 2 x 15 | 6700 | 92 | 43 | 45 | Severe | 47 | G306006/025 |
| ④ | 178 | Glasroc F FIRECASE | 2 x 15 | 7900 | 146 | 47 | 49 | Severe | 49 | G306009/028 |

▶ For further assistance in choosing the right solution for your project, try our System Selector; an online tool that enables quick and easy filtering by performance criteria. It provides system specific information downloads including BIM (Revit) objects. Go to gyproc.ie

¹ For a non-combustible solution on the shaft side use only the Glasroc F FIRECASE. On the non-shaft side this can be replaced with a layer of 15mm Gyproc FireLine or Gyproc DuraLine.

² Based on limiting deflection of L/240 at 200 Pa.

³ The acoustic performance figures quoted include ShaftWall partitions with deflection heads.

⁴ 20mm Glasroc F FIRECASE and first layer of lining board are bedded onto Gyproc Sealant, as required for pressurised air shafts, in addition to normal sealing.

⁵ Estimated rating from non-shaft side only.

(NB) The fire resistance and sound insulation performances are for imperforate partitions, but incorporating deflection heads, with all joints taped and filled, or skimmed according to Gyproc's recommendations. The quoted performances are achieved only if Gyproc and Isover components are used throughout, and the Company's fixing recommendations are strictly observed. Any variation in the specifications should be checked with Gyproc.

(NB) Gypframe Extra Deep Flange Floor & Ceiling Channel or Gypframe 'J' Channel should be used at the head. For the base Gypframe Folded Edge Standard Floor & Ceiling Channel should be used for heights up to 4200mm, Gypframe Deep Flange Floor & Ceiling Channel should be used for heights between 4200mm and 8000mm, Gypframe Extra Deep Flange Floor & Ceiling Channel should be used for heights in excess of 8000mm.

ShaftWall performance (continued)

Vertical elements

Table 3 — Limiting heights at various air pressure and allowable deflections

| Detail | System | Allowable deflection | Limiting height (mm) at stated air pressure (Pa) | | | | | | | | | System reference |
|--------|-----------|----------------------|--|------|------|------|------|------|------|------|------|-------------------------|
| | | | 200 | 240 | 300 | 360 | 400 | 480 | 500 | 600 | 650 | |
| ① | ShaftWall | L/125 | 5000 | 4700 | 4400 | 4100 | 4000 | 3800 | 3700 | 3500 | 3400 | A306001/010 |
| | | L/240 | 4200 | 4000 | 3700 | 3500 | 3300 | 3200 | 3100 | 2900 | 2800 | |
| | | L/360 | 3700 | 3500 | 3300 | 3100 | 2900 | 2800 | 2700 | 2600 | 2500 | |
| ② | ShaftWall | L/125 | 5000 | 4700 | 4400 | 4100 | 4000 | 3800 | 3700 | 3500 | 3400 | Based on A306001/010 |
| | | L/240 | 4200 | 4000 | 3700 | 3500 | 3300 | 3200 | 3100 | 2900 | 2800 | |
| | | L/360 | 3700 | 3500 | 3300 | 3100 | 2900 | 2800 | 2700 | 2600 | 2500 | |
| ③ | ShaftWall | L/125 | 7500 | 7100 | 6600 | 6200 | 6000 | 5700 | 5500 | 5200 | 5100 | A306004/011 |
| | | L/240 | 6000 | 5700 | 5300 | 5000 | 4800 | 4600 | 4400 | 4200 | 4100 | |
| | | L/360 | 5200 | 4900 | 4600 | 4300 | 4200 | 4000 | 3900 | 3600 | 3500 | |
| ④ | ShaftWall | L/125 | 5200 | 4900 | 4600 | 4300 | 4200 | 4000 | 3800 | 3600 | 3500 | A306002/012 |
| | | L/240 | 4400 | 4100 | 3800 | 3600 | 3500 | 3300 | 3200 | 3000 | 2900 | |
| | | L/360 | 3800 | 3600 | 3300 | 3100 | 3000 | 2900 | 2800 | 2600 | 2500 | |
| ⑤ | ShaftWall | L/125 | 5200 | 4900 | 4600 | 4300 | 4200 | 4000 | 3800 | 3600 | 3500 | Based on A306002/012 |
| | | L/240 | 4400 | 4100 | 3800 | 3600 | 3500 | 3300 | 3200 | 3000 | 2900 | |
| | | L/360 | 3800 | 3600 | 3300 | 3100 | 3000 | 2900 | 2800 | 2600 | 2500 | |
| ⑥ | ShaftWall | L/125 | 7900 | 7400 | 6900 | 6500 | 6300 | 5900 | 5800 | 5500 | 5300 | A306005/014 |
| | | L/240 | 6400 | 6000 | 5600 | 5200 | 5000 | 4800 | 4700 | 4400 | 4300 | |
| | | L/360 | 5600 | 5200 | 4900 | 4600 | 4400 | 4200 | 4100 | 3900 | 3800 | |
| ⑦ | ShaftWall | L/125 | 9800 | 9200 | 8600 | 8100 | 7800 | 7300 | 7200 | 6800 | 6600 | A306008/020 |
| | | L/240 | 7900 | 7400 | 6900 | 6500 | 6200 | 6000 | 5800 | 5500 | 5300 | |
| | | L/360 | 6900 | 6500 | 6000 | 5600 | 5500 | 5200 | 5100 | 4800 | 4600 | |

► For further assistance in choosing the right solution for your project, try our System Selector; an online tool that enables quick and easy filtering by performance criteria. It provides system specific information downloads including BIM (Revit) objects. Go to gyproc.ie

¹ Gyproc FireLine can be replaced with Gyproc DuraLine or Glasroc F FIRECASE.

ShaftWall performance (continued)

Vertical elements

Table 3 — Limiting heights at various air pressure and allowable deflections (continued)

| Detail | System | Allowable deflection | Limiting height (mm) at stated air pressure (Pa) | | | | | | | | | System reference |
|--------|-----------|----------------------|--|------|------|------|------|------|------|------|------|-------------------------|
| | | | 200 | 240 | 300 | 360 | 400 | 480 | 500 | 600 | 650 | |
| 8 | ShaftWall | L/125 | 5200 | 4900 | 4600 | 4300 | 4100 | 4000 | 3800 | 3600 | 3500 | A306003/023 |
| | | L/240 | 4500 | 4200 | 3900 | 3700 | 3500 | 3400 | 3300 | 3100 | 3000 | |
| | | L/360 | 3900 | 3700 | 3400 | 3200 | 3100 | 3000 | 2900 | 2700 | 2600 | |
| 9 | ShaftWall | L/125 | 5200 | 4900 | 4600 | 4300 | 4100 | 4000 | 3800 | 3600 | 3500 | Based on A306003/023 |
| | | L/240 | 4500 | 4200 | 3900 | 3700 | 3500 | 3400 | 3300 | 3100 | 3000 | |
| | | L/360 | 3900 | 3700 | 3400 | 3200 | 3100 | 3000 | 2900 | 2700 | 2600 | |
| 10 | ShaftWall | L/125 | 8400 | 7900 | 7300 | 6900 | 6600 | 6300 | 6200 | 5800 | 5600 | A306006/025 |
| | | L/240 | 6700 | 6300 | 5900 | 5500 | 5300 | 5100 | 5000 | 4700 | 4500 | |
| | | L/360 | 5600 | 5300 | 4900 | 4600 | 4500 | 4200 | 4100 | 3900 | 3800 | |
| 11 | ShaftWall | L/125 | 9900 | 9300 | 8600 | 8100 | 7800 | 7400 | 7200 | 6800 | 6600 | A306009/028 |
| | | L/240 | 7900 | 7400 | 6900 | 6500 | 6300 | 6000 | 5800 | 5500 | 5300 | |
| | | L/360 | 6900 | 6500 | 6000 | 5700 | 5500 | 5200 | 5100 | 4800 | 4700 | |

► For further assistance in choosing the right solution for your project, try our System Selector; an online tool that enables quick and easy filtering by performance criteria. It provides system specific information downloads including BIM (Revit) objects. Go to gyproc.ie

These tables give the limiting heights for ShaftWall systems when subjected to air pressures ranging from 200 Pa through to 650 Pa and at three allowable deflection levels - L/125, L/240, L/360. Partition heights are normally quoted for air pressures of 200 Pa at an allowable deflection of L/240.

When the fire performance of ShaftWall is specified in terms of EN 1364-1: 1999, then the maximum height cannot exceed that given in the relevant table in this book, irrespective of air pressure or allowable deflection.

¹ Gyproc FireLine can be replaced with Gyproc DuraLine or Glasroc F FIRECASE.

NB Gypframe Extra Deep Flange Floor & Ceiling Channel or Gypframe 'J' Channel should be used at the head. For the base Gypframe Folded Edge Standard Floor & Ceiling Channel should be used for heights up to 4200mm, Gypframe Deep Flange Floor & Ceiling Channel should be used for heights between 4200mm and 8000mm, Gypframe Extra Deep Flange Floor & Ceiling Channel should be used for heights in excess of 8000mm.

ShaftWall performance (continued)

Horizontal elements

For details of when to specify fire resistance using EN
 ▶ Refer to C02. S01. P18



Table 4a – Solutions to satisfy the requirements of BS EN 1364-2: 1999

①

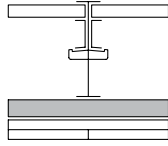

Gypframe 60, 70 or 92mm 'I' Stud or Gypframe 146 TI 90 Tabbed 'I' Stud frames at 600mm centres with Gyproc CoreBoard between studs, secured by Gypframe Retaining Channel. 25mm Isover Acoustic Roll in cavity (optional). Gypframe MF5 Ceiling Sections fixed to ceiling side at 450mm centres. Lining boards to ceiling side, see table.

②

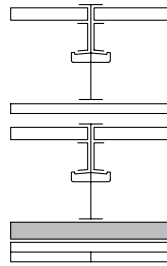

Two Gypframe 146 TI 90 Tabbed 'I' Stud frames at 600mm centres with Gyproc CoreBoard between studs, secured by Gypframe Retaining Channel. 25mm Isover Acoustic Roll in cavity (optional). On the lower framework only, Gypframe MF5 Ceiling Sections fixed to ceiling side at 450mm centres. Lining boards to ceiling side, see table.

③

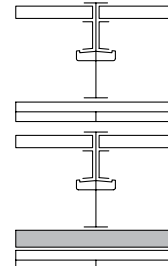

Two Gypframe 146 TI 90 Tabbed 'I' Stud frames at 600mm centres with Gyproc CoreBoard between studs, secured by Gypframe Retaining Channel. 25mm Isover Acoustic Roll in cavity (optional). On the lower framework only, Gypframe MF5 Ceiling Sections fixed to ceiling side at 450mm centres. Lining boards to ceiling side, see table.

| Detail | Thickness mm | Lining boards to non-shaft side | | Max. span ¹ mm | Stud size mm | Sound insulation R_w dB | | Approx. weight kg/m ² | System reference |
|---|--------------|--|----------------------|---------------------------|--------------|---------------------------|---|----------------------------------|------------------|
| | | Board type | Lining thickness mm | | | No insulation | Sealed structure plus 25mm Isover Acoustic Roll | | |
| 60 minutes fire resistance (EN) | | | | | | | | | |
| ① | 120 | Gyproc FireLine | 2 x 15 | 2500 | 60 | 42 | 45 | 39 | C106053 |
| ① | 130 | Gyproc FireLine | 2 x 15 | 2800 | 70 | 42 | 45 | 39 | C106053 |
| ① | 152 | Gyproc FireLine | 2 x 15 | 3000 | 92 | 44 | 46 | 39 | C106054 |
| ① | 206 | Gyproc FireLine | 2 x 15 | 4400 | 146 | 48 | 50 | 39 | C106055 |
| 90 minutes fire resistance (EN) | | | | | | | | | |
| ② | 397 | { Gyproc FireLine upper frame Gyproc FireLine lower frame | { 1 x 15 2 x 15 } | 4400 | 146 | 48 | 50 | 77 | C106057 |
| 120 minutes fire resistance (EN) | | | | | | | | | |
| ③ | 422 | { Gyproc FireLine upper frame Gyproc FireLine lower frame | { 2 x 15 2 x 15 } | 4000 | 146 | 48 | 50 | 88 | C106056 |

▶ For further assistance in choosing the right solution for your project, try our System Selector; an online tool that enables quick and easy filtering by performance criteria. It provides system specific information downloads including BIM (Revit) objects. Go to gyproc.ie

¹Based on fire state field of application, or by a limiting deflection of L/400, whichever is greater.

(NB) The fire resistance and sound insulation performances are for imperforate ceilings incorporating boards, with all joints taped and filled, or skimmed according to Gyproc's recommendations. The quoted performances are achieved only if Gyproc and Isover components are used throughout, and the Company's fixing recommendations are strictly observed. Any variation in the specifications should be checked with Gyproc.

(NB) ShaftWall used horizontally should not be used for materials storage or access for personnel, or to provide support to services.

(NB) Gypframe Extra Deep Flange Floor & Ceiling Channel or Gypframe 'J' Channel should be used at perimeter.



Table 4b – Solutions to satisfy requirements of BS 476: Part 22: 1987

①

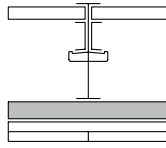

Gypframe 60, 70 or 92mm 'I' Stud or Gypframe 146 TI 90 Tabbed 'I' Stud frames at 600mm centres with Gyproc CoreBoard between studs, secured by Gyproc Retaining Channel. 25mm Isover Acoustic Roll in cavity (optional). Gypframe MF5 Ceiling Sections fixed to ceiling side at 450mm centres. Lining boards to ceiling side, see table.

②

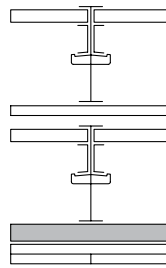

Two Gypframe 146 TI 90 Tabbed 'I' Stud frames at 600mm centres with Gyproc CoreBoard between studs, secured by Gyproc Retaining Channel. 25mm Isover Acoustic Roll in cavity (optional). On the lower framework only, Gypframe MF5 Ceiling Sections fixed to ceiling side at 450mm centres. Lining boards to ceiling side, see table.

③

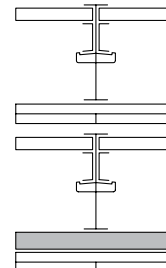

Two Gypframe 146 TI 90 Tabbed 'I' Stud frames at 600mm centres with Gyproc CoreBoard between studs, secured by Gyproc Retaining Channel. 25mm Isover Acoustic Roll in cavity (optional). On the lower framework only, Gypframe MF5 Ceiling Sections fixed to ceiling side at 450mm centres. Lining boards to ceiling side, see table.

| Detail | Thickness mm | Lining boards to non-shaft side | | Max. span ¹ mm | Stud size mm | Sound insulation R_w dB | | Approx. weight kg/m ² | System reference |
|------------------------------------|--------------|--|----------------------|---------------------------|--------------|---------------------------|---|----------------------------------|------------------|
| | | Board type | Lining thickness mm | | | No insulation | Sealed structure plus 25mm Isover Acoustic Roll | | |
| 60 minutes fire resistance | | | | | | | | | |
| ① | 120 | Gyproc FireLine | 2 x 15 | 2500 | 60 | 42 | 45 | 39 | C106053 |
| ① | 130 | Gyproc FireLine | 2 x 15 | 2800 | 70 | 42 | 45 | 39 | C106053 |
| ① | 152 | Gyproc FireLine | 2 x 15 | 3700 | 92 | 44 | 46 | 39 | C106054 |
| ① | 206 | Gyproc FireLine | 2 x 15 | 5100 | 146 | 48 | 50 | 39 | C106055 |
| 90 minutes fire resistance | | | | | | | | | |
| ② | 397 | { Gyproc FireLine upper frame Gyproc FireLine lower frame } | { 1 x 15 2 x 15 } | 5100 | 146 | 48 | 50 | 77 | C106057 |
| 120 minutes fire resistance | | | | | | | | | |
| ③ | 422 | { Gyproc FireLine upper frame Gyproc FireLine lower frame } | { 2 x 15 2 x 15 } | 5100 | 146 | 48 | 50 | 88 | C106056 |

▶ For further assistance in choosing the right solution for your project, try our System Selector; an online tool that enables quick and easy filtering by performance criteria. It provides system specific information downloads including BIM (Revit) objects. Go to gyproc.ie

¹Based on a limiting deflection of L/400.

NB The fire resistance and sound insulation performances are for imperforate ceilings incorporating boards, with all joints taped and filled, or skimmed according to Gyproc's recommendations. The quoted performances are achieved only if Gyproc and Isover components are used throughout, and the Company's fixing recommendations are strictly observed. Any variation in the specifications should be checked with Gyproc.

NB ShaftWall used horizontally should not be used for materials storage or access for personnel, or to provide support to services.

NB Gypframe Extra Deep Flange Floor & Ceiling Channel or Gypframe 'J' Channel should be used at perimeter.

ShaftWall design

Building design

ShaftWall comprises Gypframe 'I' Studs and Gypframe Starter Channels within Gypframe Floor & Ceiling Channels.

The shaft-side boards are retained between the Gypframe Floor & Ceiling Channels and adjacent studs using Gypframe Retaining Channels; which enables construction from the side only.

Planning – key factors

The position of services should be pre-determined and their installation planned into the frame erection stage. Timber sole plates should be considered, if appropriate, where the floor is uneven.

► Refer to C02. S01. P41 – Service installations.



Important information

When exposed to fire from the corridor side in accordance with *BS 476: Part 22*, an insulation failure will occur. If relaxation from Building Control is not given and a full fire rating (insulation and integrity) is required in both directions, the following options are available:

- Use equivalent *EN 1364-1* specification, e.g. if 60 minutes *BS 476: Part 22* performance is required, use a 60 minutes *EN 1364-1* specification
- Specify the next level of fire performance from BS table, e.g. if 60 minutes *BS 476: Part 22* performance is required, use a 90 minute *BS 476: Part 22* specification¹

It is important that a good standard of control is exercised on site to ensure that the adoption of drylining techniques at such an early stage of construction is fully integrated into the site planning programme. If the building envelope is left unsealed while ShaftWall is under construction, Gyproc FireLine MR, Gyproc DuraLine MR or Glasroc F FIRECASE should be used for the lining. All penetrations will need to be adequately fire-stopped.



Important information

For ShaftWall systems utilising Gypframe 60 I 70 'I' Studs, Gypframe 62 JC 70 'J' Channel with its asymmetrical legs is needed at the head to facilitate the installation of the Gyproc CoreBoard. The shorter leg is installed facing the non-shaft side. For ShaftWall systems that use wider Gypframe 'I' studs, the appropriate Gypframe Extra Deep Flange Floor and Ceiling Channel should be used.

Fixing the floor channel

The floor channel must have continuous support along its length to maintain specified performance levels. If continuous support is not provided by the structure, e.g. Z-sections running transverse to a steel beam, the designer should detail the installation of a rigid non-combustible material between the Z-sections. Z-sections need to be protected and remain in-situ in the event of a fire, taking into account any loads they are supporting.

In situations where the floor channel is fixed to diagonal structural steel, the studs should be accurately scribed to the rake of the channel to maintain the full bearing surface.

Fixing to metal decking

Where ShaftWall is to be located transverse to the profiles of the decking, all slots or perforations above the head channel should be sealed using a proprietary fire barrier or fire spray. Fire-stopping material can be applied prior to the head channel being positioned, providing that any surplus is removed flush with the steel decking.

Fixing to structural steel encasements

Where ShaftWall abuts a column or beam encasement, the framing will generally require fixing to the structural steelwork.

Where ShaftWall abuts the web of the steelwork a Z-section can be located to provide a fixing point level with the flanges of the steelwork. With FireCase encasements, where fire resistance up to 60 minutes and a Light or Medium Duty Rating to *BS 5234* is required, it is possible to fix directly to the board cladding subject to fire resistance and loading criteria.

► Refer to C03. S02. P84 – FireCase construction details.



Handy hint

Where the floor channel is not fully supported, e.g. at the edge of a floor slab, Gypframe Extra Deep Flange Floor & Ceiling Channel or Gypframe 'J' Channel must be used with a continuous 19mm Gyproc CoreBoard fire stop inserted into the base of the channel. The maximum allowable overhang is 25% of the floor channel width.

Limiting heights at different air pressures

The maximum heights quoted in the performance tables for vertical elements are based on a limiting deflection of L/240 at 200 Pa, or by the fire state field of application. In practice, deflection from L/125 to L/360 may be allowed and pressure conditions between 200 Pa and 650 Pa may be encountered. These variations will affect the maximum wall height. Refer to table 3.

¹ Where 120 mins is required to *BS 476: Part 22*, replace the inner layer of 15mm Gyproc FireLine (corridor side) with 19mm Gyproc CoreBoard, fixed horizontally.

ShaftWall design (continued)

Connection to the structure

Structural steelwork and its associated connections often result in complex junctions around shafts. If **ShaftWall** is built on the same line as the beamwork framing the shaft, problems may arise in trying to seal the wall up to the steelwork. It is recommended that, wherever possible, the wall should be located to one side of the beams, and fixed from structural floor to structural soffit.

Partition to structural steelwork junctions

When designing the layout of rooms requiring separation by sound insulating walls abutting structural steelwork, consideration should be given to the potential loss of sound insulation performance through the steelwork.

► Refer to C02. S01. P21 – Building acoustics.

Door openings

In the case of both normal access doors and lift doors, the door and frame assembly must have been shown by a fire resistance test to achieve the required standard of performance in this form of construction.

Lift doors must be substantiated in conjunction with **ShaftWall** complete with their framing members and transom panels. To achieve a satisfactory level of compatibility, a suitable starter channel should be mechanically fixed to the door frame at 300mm centres.

► Refer to construction details 23-25 within this section.

Pressurised airshafts and service ducts

The use of pressure conditions in various types of shaft / duct requires that the boards should be sealed into the framing members using Gyproc Sealant in addition to the normal sealing of the framing to adjoining structures. It is essential that these areas are identified at a very early stage of the contract, and that other trades are instructed to recognise the need for the application of sealant and its replacement if subsequently damaged or removed. In order that the integrity of the pressurised system can be maintained, Gyproc Sealant should be specified for all board-to-metal applications, and the sealing of Gyproc CoreBoard (or Glasroc F FIRECASE) to the framing.

► Refer to construction details 17-20 within this section.

Control joints

Control joints may need to be considered in conditions where excessive movement is likely to occur, or to coincide with constructional expansion joints. In order that the deflection criteria can be maintained throughout the building, it is necessary to introduce horizontal movement joints in the lining where this would normally be required to extend through the height of the building, e.g. stairwells.

The horizontal movement joint can be accommodated adjacent to the floor slab.

► Refer to construction detail 28 within this section.

Deflection heads

Deflection heads, by definition, must be able to move and, therefore, achieving an airtight seal is difficult. Inevitably, this will have a detrimental effect on the acoustic performance of any wall that incorporates deflection at the head. In most cases, a suspended ceiling will assist in minimising loss of performance.

► Refer to construction details 11-17 for standard head details.

Gyproc FireStrip must be applied as a continuous seal where indicated to maintain fire performance. Also, board fixings must not be inserted above the uppermost line depicted by the red arrow in each drawing. Designs incorporating Gypframe Retaining Clips are not suitable for live loads. Where greater deflection needs to be accommodated, contact the Gyproc Technical Department for further guidance.

Deflection criteria

Partitions built to a maximum height based on L/125 at 200 Pa will exhibit greater deflection compared to partitions built to a maximum height based on L/240 at 200 Pa. Partitions with deflection characteristics outside the standard L/240 criteria will exhibit more flex during installation and in general use, and therefore we recommend you verify the acceptability of the deflections with the relevant interested parties before specifying / installing partitions based on L/125 criteria.

Services

Penetrations

Penetrations of fire-resistant constructions for services should be minimised, however if essential, careful consideration should be given to ensure that the integrity of the element is not impaired, and that the services themselves do not act as the mechanism of fire spread.

► Refer to C02. S01. P41 – Service installations.

Independent support

When designing for the installation of services such as fire dampers and associated ductwork through **ShaftWall**, consideration should be given to the size and weight of the damper – this will determine whether it can be supported directly from the partition or needs to be independently supported from the structure.

► Refer to C04. S01. P122 – Partitions introduction, construction details 29-31.

Openings bridging studs

Openings should be constructed using channels for the trimming members. The web of the channel should be rebated to allow the flanges to oversail the stud. The flanges are secured with two fixings. Channels are cut and inserted to maintain the 25mm gap surround and fixed to the trimming channels.

► Refer to construction detail 21 within this section.



Important information

The quoted sound insulation performances of **ShaftWall**, detailed in the preceding performance tables, incorporate a deflection head as part of the tested construction. Therefore, this effectively downgrades the sound insulation performance of the system. To minimise the loss, install Gypframe GA4 Steel Angle at the head, which will improve the performance by approximately 2-3dB, refer to C02. S01. P21 – Building acoustics. Further sound insulation improvement can be achieved by substituting Gyproc DuraLine in lieu of Gyproc FireLine, providing 1-2dB improvement. The installation of a Gypframe RB1 Resilient Bar may further improve performance, contact the Gyproc Technical Department for further information.

Openings between studs

The opening is constructed using channels for the trimming members. The web should be rebated and the flanges allowed to oversail the studs. The stud is secured with two fixings. Channels are cut and inserted with the webs folded to provide fixings. A plasterboard packer is inserted adjacent to the stud.

▶ Refer to construction detail 22 within this section.

Electrical services

The installation of electrical services should be carried out in accordance with *BS 7671*. The positions for light switches and other electrical outlets should be pre-determined in order that provision can be made for support, and also for the fire integrity of the system.

Gypframe 99 FC 50 Fixing Channel should be cut to bridge adjoining studs, with the edges flattened to permit fixing. The fixing channel should be backed with stone mineral wool. Gyproc FireLine (or Glasroc F FIRECASE) linings should be cut to allow a close fitting entry of the switch box which can be secured to the fixing channel.

▶ Refer to construction detail 7 within this section.

Access for maintenance

For access doors, openings should be framed to avoid impairing the structural or fire-resistant properties of **ShaftWall**. To provide an opening ready to receive a door set, the jambs to storey height should be capped with Gypframe 'J' Channel incorporating a plasterboard packer. A pre-formed spandrel panel assembled between starter channels should be inserted between jambs and engaged into the head channel, retaining the 15mm gap for deflection at the head.

▶ Refer to construction detail 23 within this section.

Support is provided by a Gypframe 'J' Channel transom. The door frame is secured to both Gypframe 'I' Stud and Gypframe 'J' Channel jambs and also to the transom member.

▶ Refer to construction detail 25 within this section.

A range of Gyproc Profilex Access Panels providing fire integrity is available. Please contact the Gyproc Technical Department for further information:

ROI: 1800 744480

NI: 0845 3990159

Email: tech.ie@saint-gobain.com

Board finishing

▶ Refer to C08. S01. P517 – Finishes.

Tiling

Tiles can be applied to the surface of lightweight partition systems.

▶ Refer to C08. S04. P531 – Tiling.

Horizontal ShaftWall

ShaftWall can be specified for horizontal applications as a free-spanning membrane with no support from the soffit. The membrane can be constructed entirely from below and can achieve spans up to 5100mm and fire resistance up to 120 minutes. A typical application is for fire escape corridors. Services should be independently supported from the building structure.

Supporting partitions should be of at least the same fire resistance period as the horizontal **ShaftWall**.



SpecSure®

SpecSure®

All our systems are covered by SpecSure® when using genuine Gyproc and Isover products.

ShaftWall construction details

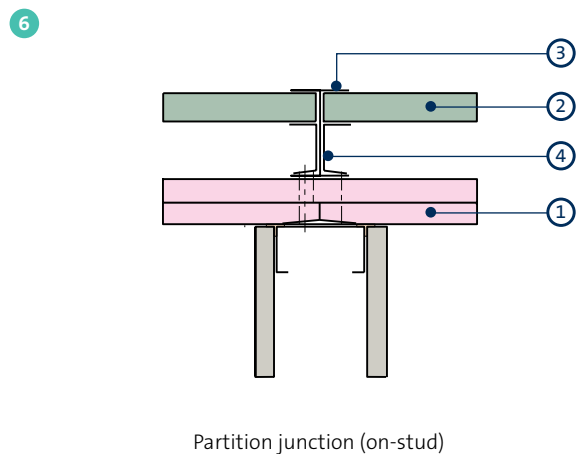
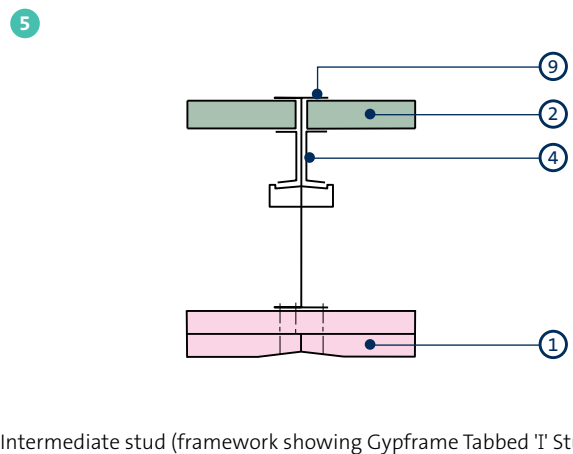
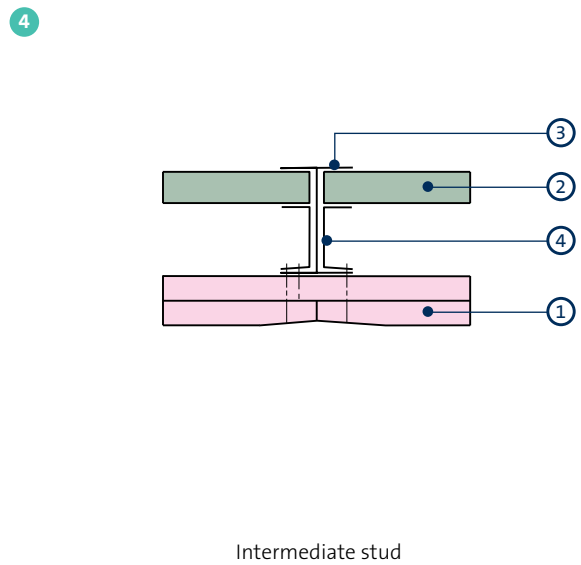
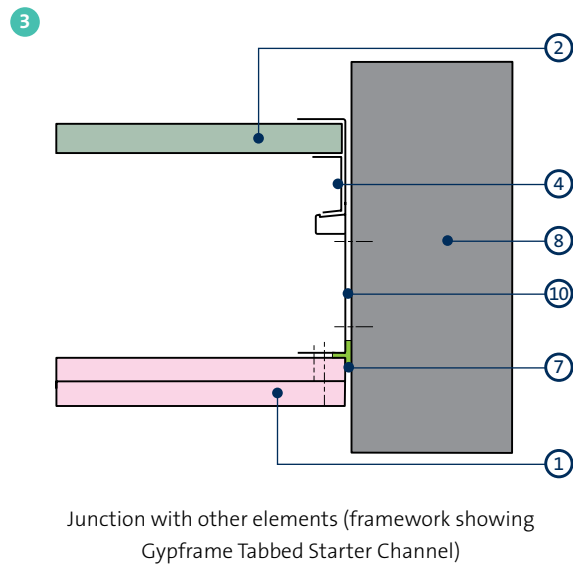
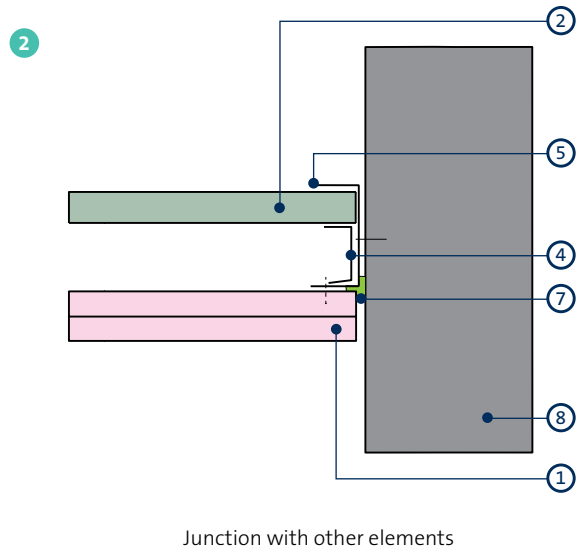
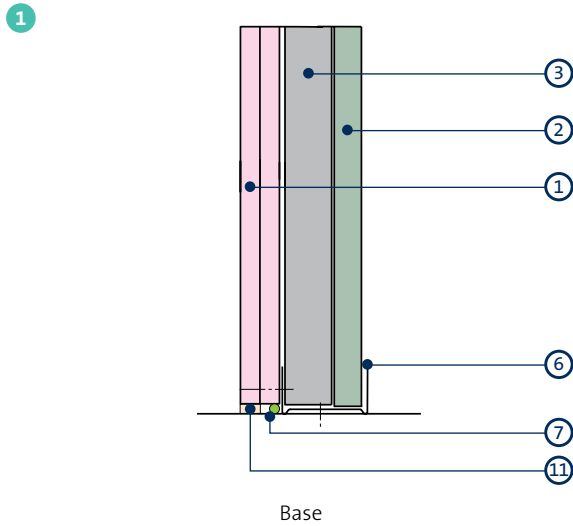

- 1 Gyproc FireLine¹
- 2 Gyproc CoreBoard²
- 3 Gypframe 'T' Stud
- 4 Gypframe Retaining Channel
- 5 Gypframe Starter Channel
- 6 Gypframe Folded Edge Standard Floor & Ceiling Channel

- 7 Gyproc Sealant
- 8 Structure
- 9 Gypframe Tabbed 'T' Stud
- 10 Gypframe Tabbed Starter Channel
- 11 Bulk fill with Gyproc jointing materials (where gap exceeds 5mm)

¹ Replace with 15mm Glasroc F FIRECASE for systems with non-combustible linings.

² Replace with 20mm Glasroc F FIRECASE for systems with non-combustible linings.

ShaftWall construction details (continued)

7

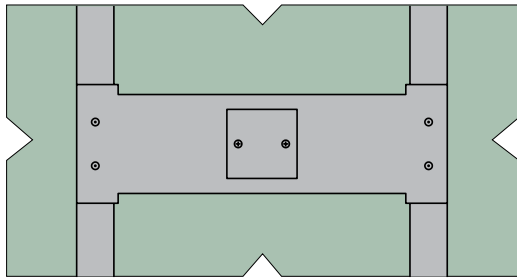
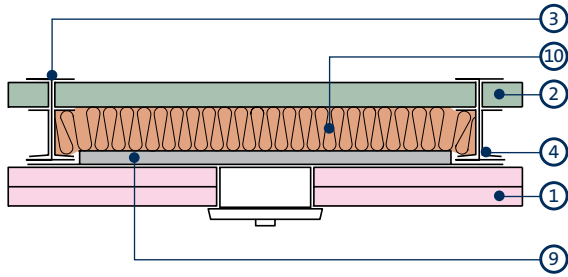

Socket box

8

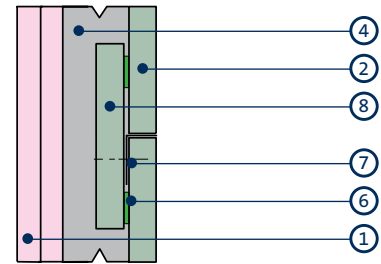

Horizontal Gyproc CoreBoard joints

9

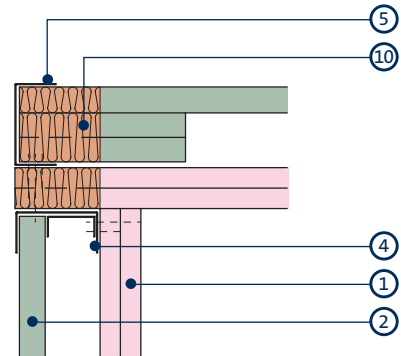

Internal corner

10

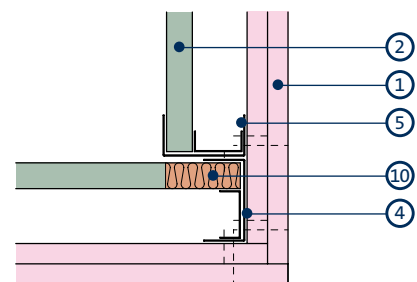

External corner

- 1 Gyproc FireLine¹
- 2 Gyproc CoreBoard²
- 3 Gypframe T Stud
- 4 Gypframe Retaining Channel
- 5 Gypframe Starter Channel

- 6 Gyproc Sealant
- 7 Gypframe GA3 Steel Angle
- 8 Gyproc CoreBoard strip (cut on site)²
- 9 Gypframe 99 FC 50 Fixing Channel
- 10 Stone mineral wool (100kg/m³ - by others)

¹ Replace with 15mm Glasroc F FIRECASE for systems with non-combustible linings.

² Replace with 20mm Glasroc F FIRECASE for systems with non-combustible linings.

ShaftWall construction details (continued)

Head details incorporating 15mm downward deflection

11

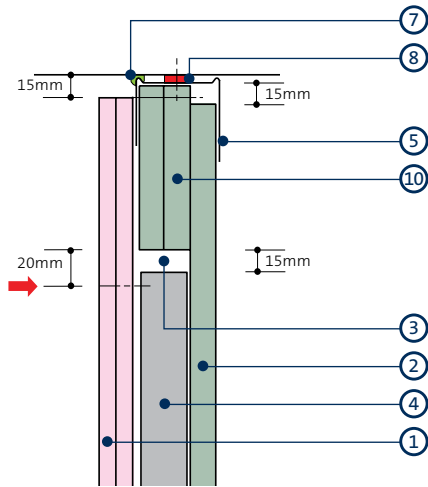

60mm framework (live loads)³

12

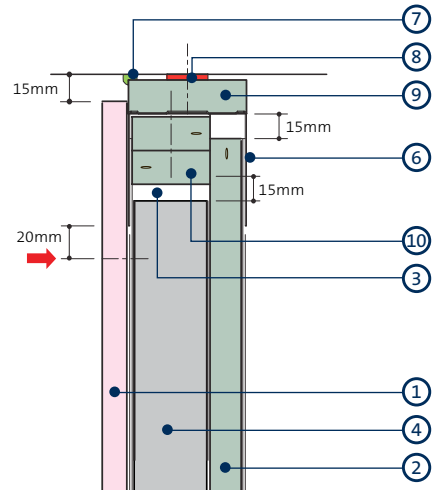

70mm framework (live loads)

13

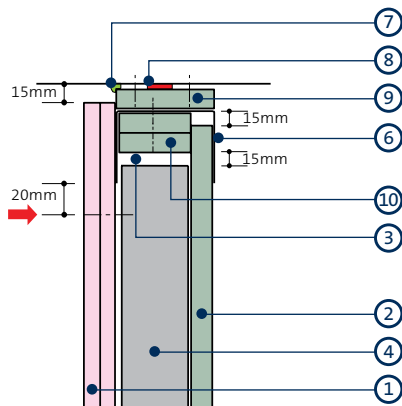

92mm framework (live loads)

14

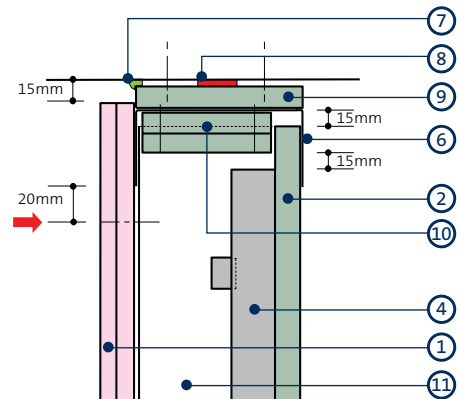

146mm framework (live loads)

- 1 Gyproc FireLine¹
- 2 Gyproc CoreBoard²
- 3 Gypframe 'I' Stud
- 4 Gypframe Retaining Channel
- 5 Gypframe 'J' Channel
- 6 Gypframe Extra Deep Flange Floor & Ceiling Channel

- 7 Gyproc Sealant
- 8 Gyproc FireStrip
- 9 Gyproc CoreBoard²
- 10 Gyproc CoreBoard fire-stop²
- 11 Gypframe Tabbed 'I' Stud

¹ Replace with 15mm Glasroc F FIRECASE for systems with non-combustible linings.

² Replace with 20mm Glasroc F FIRECASE for systems with non-combustible linings.

³ Vertical fire-stops are not recommended for non-combustible linings, use horizontal fire-stops similar to detail 12.

NB No fixings should be made through the boards into the flanges of the head channel. The arrow (➔) denotes the position of the uppermost board fixing.

ShaftWall construction details (continued)

Head details with Retaining Clips

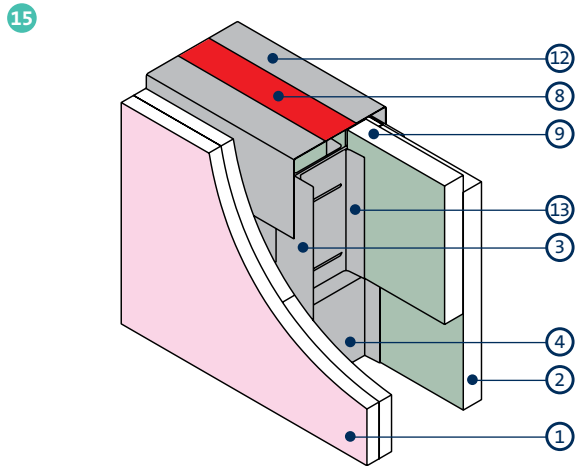

Head incorporating Gypframe G108 Retaining Clip (92mm)

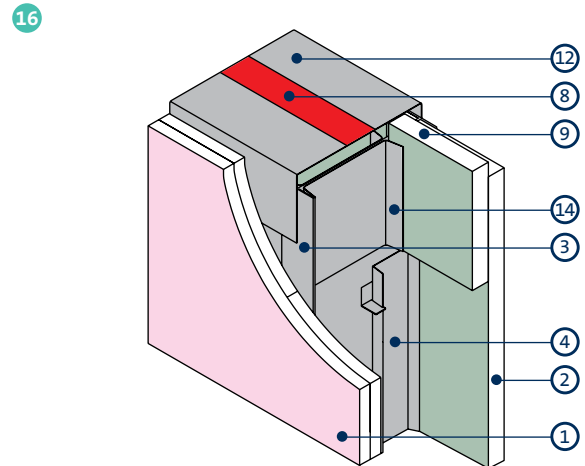

Head incorporating Gypframe G109 Retaining Clip (146mm)

Sealing pressurised air shafts and service ducts

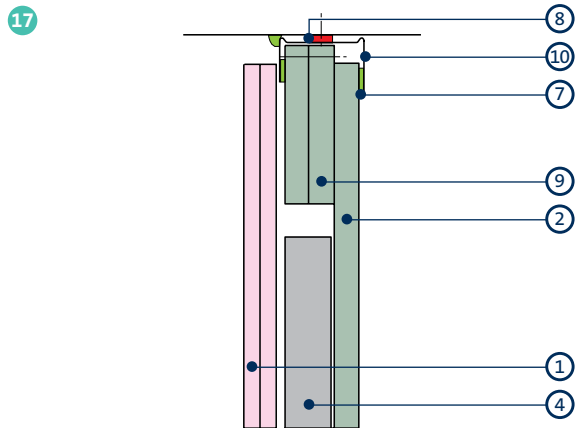

Head (sealed structure). Example shows 60mm stud³

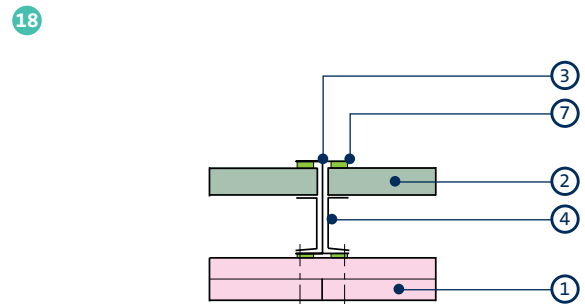

Intermediate stud (sealed structure)

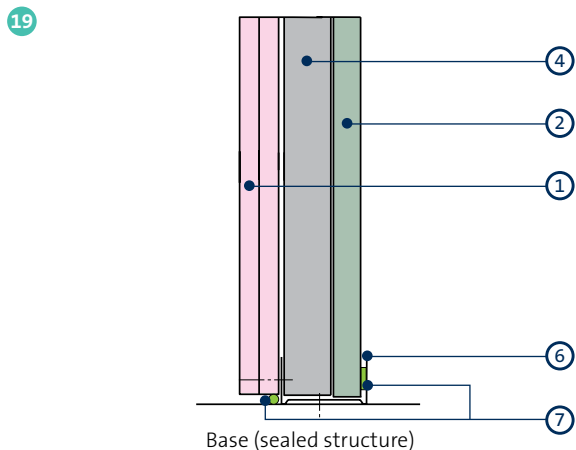

Base (sealed structure)

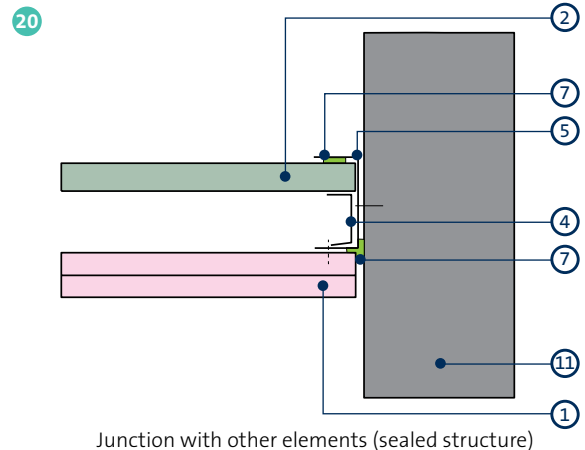

Junction with other elements (sealed structure)

- 1 Gyproc FireLine¹
- 2 Gyproc CoreBoard²
- 3 Gypframe 'I' Stud
- 4 Gypframe Retaining Channel
- 5 Gypframe Starter Channel
- 6 Gypframe Folded Edge Standard Floor & Ceiling Channel
- 7 Gyproc Sealant

- 8 Gyproc FireStrip
- 9 Gyproc CoreBoard fire-stop (cut on site)²
- 10 Gypframe 'J' Channel
- 11 Structure
- 12 Gypframe Extra Deep Flange Floor & Ceiling Channel
- 13 Gypframe G108 Retaining Clip
- 14 Gypframe G109 Retaining Clip

¹ Replace with 15mm Glasroc F FIRECASE for systems with non-combustible linings.

² Replace with 20mm Glasroc F FIRECASE for systems with non-combustible linings.

³ Use alternative deflection head detail for systems with non-combustible linings.

21

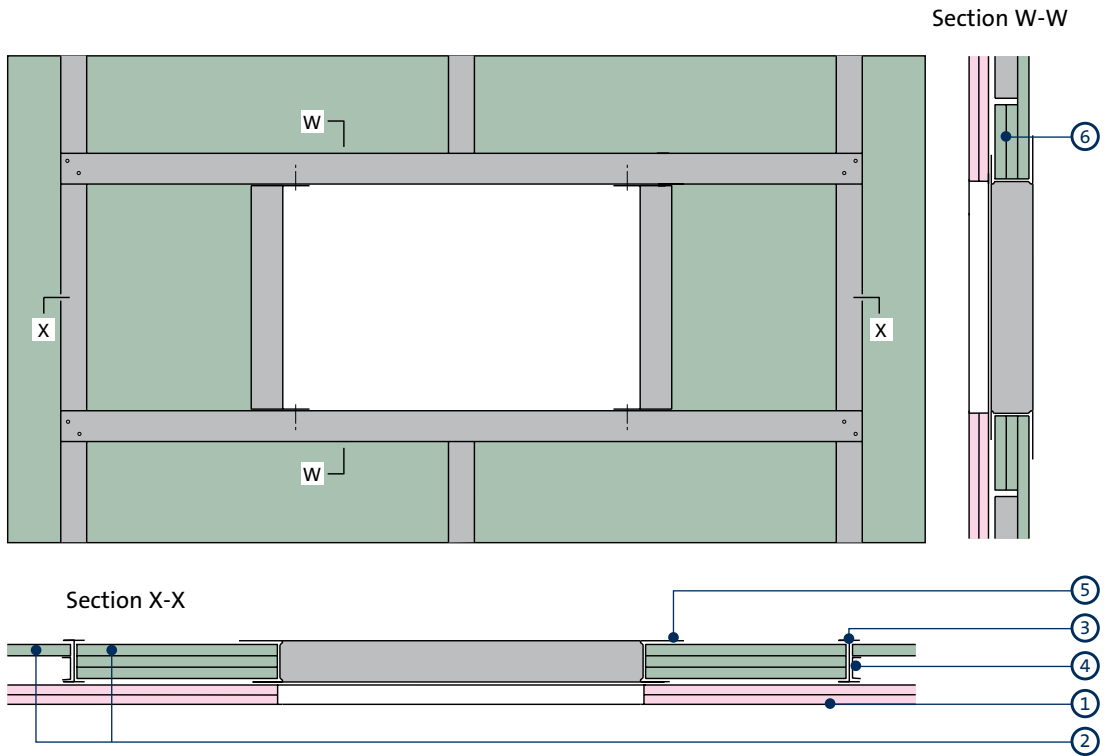

Opening bridging studs. Example shows 60mm stud

22

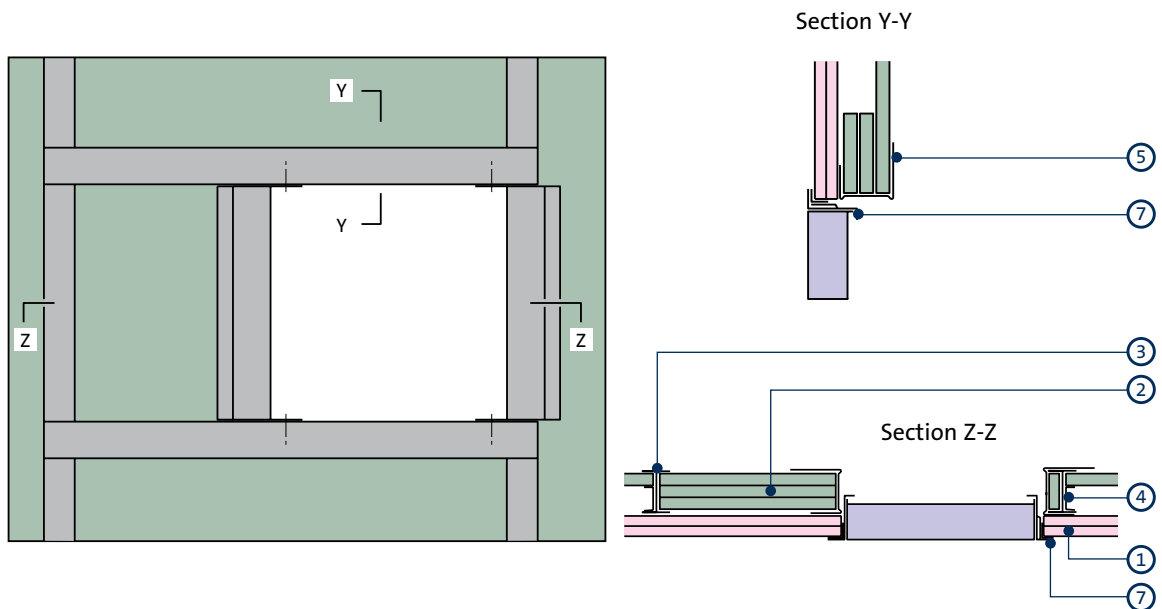

Opening between studs. Example shows 60mm stud

- 1 Gyproc FireLine
- 2 Gyproc CoreBoard
- 3 Gypframe T Studs
- 4 Gypframe Retaining Channel

- 5 Gypframe J Channel
- 6 Gyproc CoreBoard fire-stops (cut on site)
- 7 Access panel frame (by others)

ShaftWall construction details (continued)

23

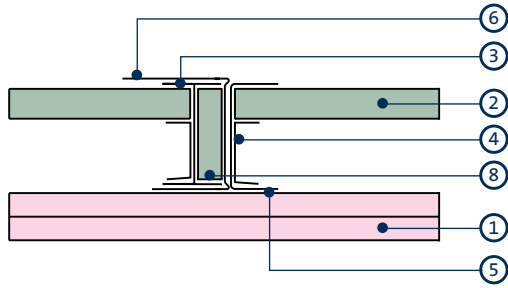

Access door - spandrel panel

24

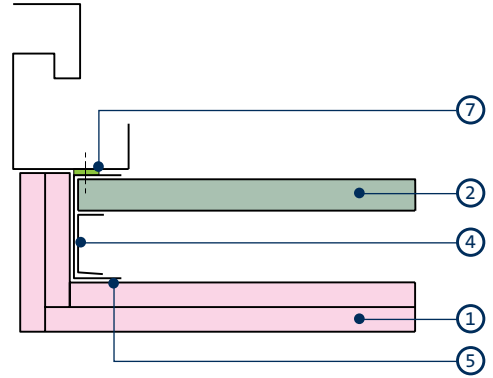

Lift door (Gypframe Starter Channel mechanically fixed to frame)

25

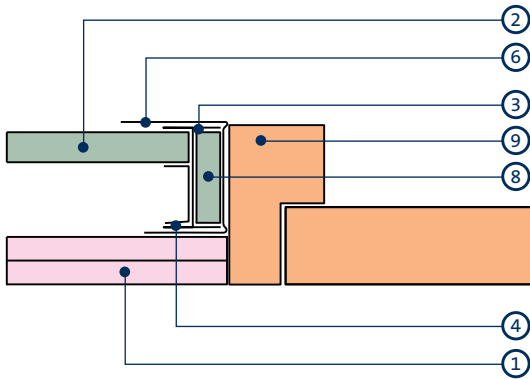

Access door jamb

- 1 Gyproc FireLine¹
- 2 Gyproc CoreBoard²
- 3 Gypframe 'I' Stud
- 4 Gypframe Retaining Channel
- 5 Gypframe Starter Channel

- 6 Gypframe 'J' Channel
- 7 Gyproc Sealant
- 8 Gyproc CoreBoard packer (cut on site)²
- 9 Door frame

¹ Replace with 15mm Glasroc F FIRECASE for systems with non-combustible linings.

² Replace with 20mm Glasroc F FIRECASE for systems with non-combustible linings.

26

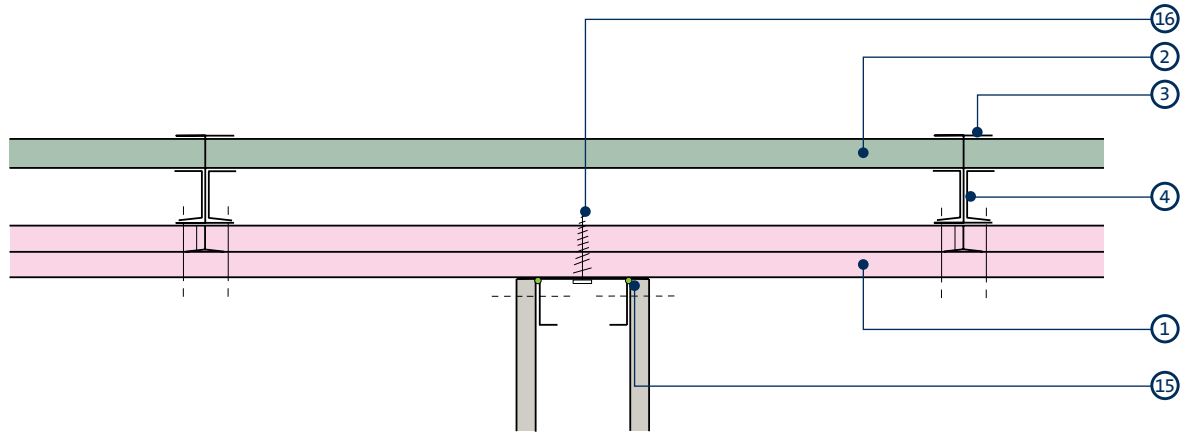

Retro-fit non-performance partition junction

Connection to the structure

27

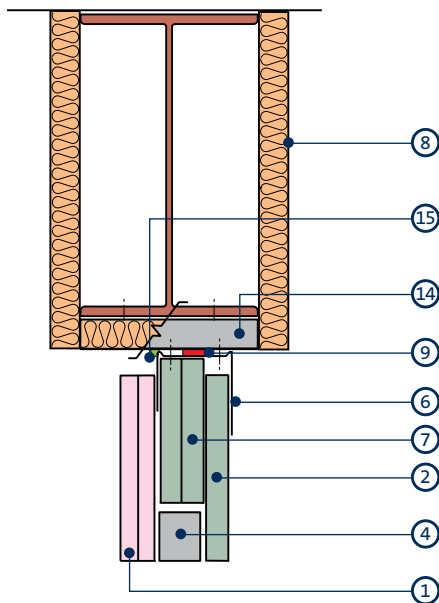

Fixing head channel to Z-section at underside of beams³

28

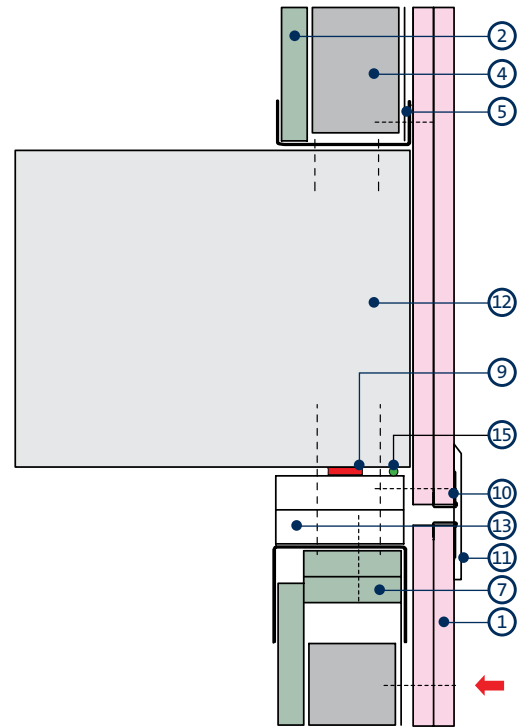

Control joint at floor slab junction where lining boards continue

- 1 Gyproc FireLine¹
- 2 Gyproc CoreBoard²
- 3 Gypframe 'I' Stud
- 4 Gypframe Retaining Channel
- 5 Gypframe Floor & Ceiling Channel
- 6 Gypframe 'J' Channel
- 7 Gyproc CoreBoard fire-stops²
- 8 Beam encasement

- 9 Gyproc FireStrip
- 10 Gyproc Edge Bead - if no cover strip is used
- 11 Cover strip (by others)
- 12 Structure
- 13 Glasroc F FIRECASE
- 14 Z-section (by others)
- 15 Gyproc Sealant
- 16 Suitable metal self-drive fixing (by others)

¹ Replace with 15mm Glasroc F FIRECASE for systems with non-combustible linings.

² Replace with 20mm Glasroc F FIRECASE for systems with non-combustible linings.

³ Use alternative deflection head detail for systems with non-combustible linings.

NB No fixings should be made through the boards into the flanges of the head channel. The arrow (←) denotes the position of the uppermost board fixing.

ShaftWall construction details (continued)

29

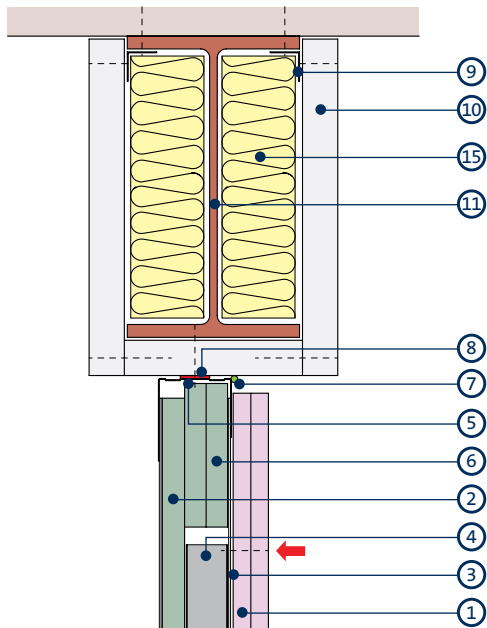

Beam encasement and partition junction for partitions to satisfy
BS 5234: Parts 1 & 2: 1992 Heavy and Severe Duty Rating

30

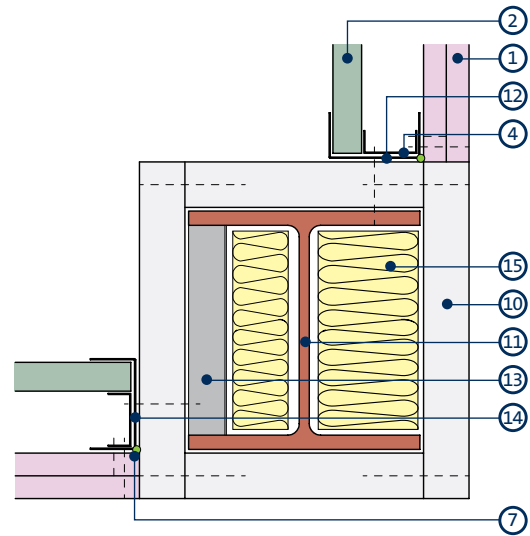

Column encasement and partition junction for partitions up to
120 minutes fire resistance and BS 5234 Parts 1 & 2: 1992
Heavy and Severe Duty Rating

- 1 Gyproc FireLine¹
- 2 Gyproc CoreBoard²
- 3 Gypframe 'I' Stud
- 4 Gypframe Retaining Channel
- 5 Gypframe 'J' Channel suitably fixed through encasement to structure
- 6 Gyproc CoreBoard fire-stops²
- 7 Gyproc Sealant
- 8 Gyproc FireStrip
- 9 Gypframe GA1 Steel Angle

- 10 Glasroc F FIRECASE
- 11 Structural steel
- 12 Gypframe Starter Channel suitably fixed through Glasroc F FIRECASE to column at 600mm centres (in two lines staggered by 300mm for studs wider than 75mm)
- 13 Suitable size Z-section (by others) fixed between column flanges at 600mm centres
- 14 Gypframe Starter Channel suitably fixed through Glasroc F FIRECASE to Z-sections (in two lines staggered by 300mm for studs wider than 75mm).
- 15 Isover insulation if required to minimise acoustic downgrade

¹ Replace with 15mm Glasroc F FIRECASE for systems with non-combustible linings.

² Replace with 20mm Glasroc F FIRECASE for systems with non-combustible linings.

NB No fixings should be made through the boards into the flanges of the head channel. The arrow (←) denotes the position of the uppermost board fixing.

31

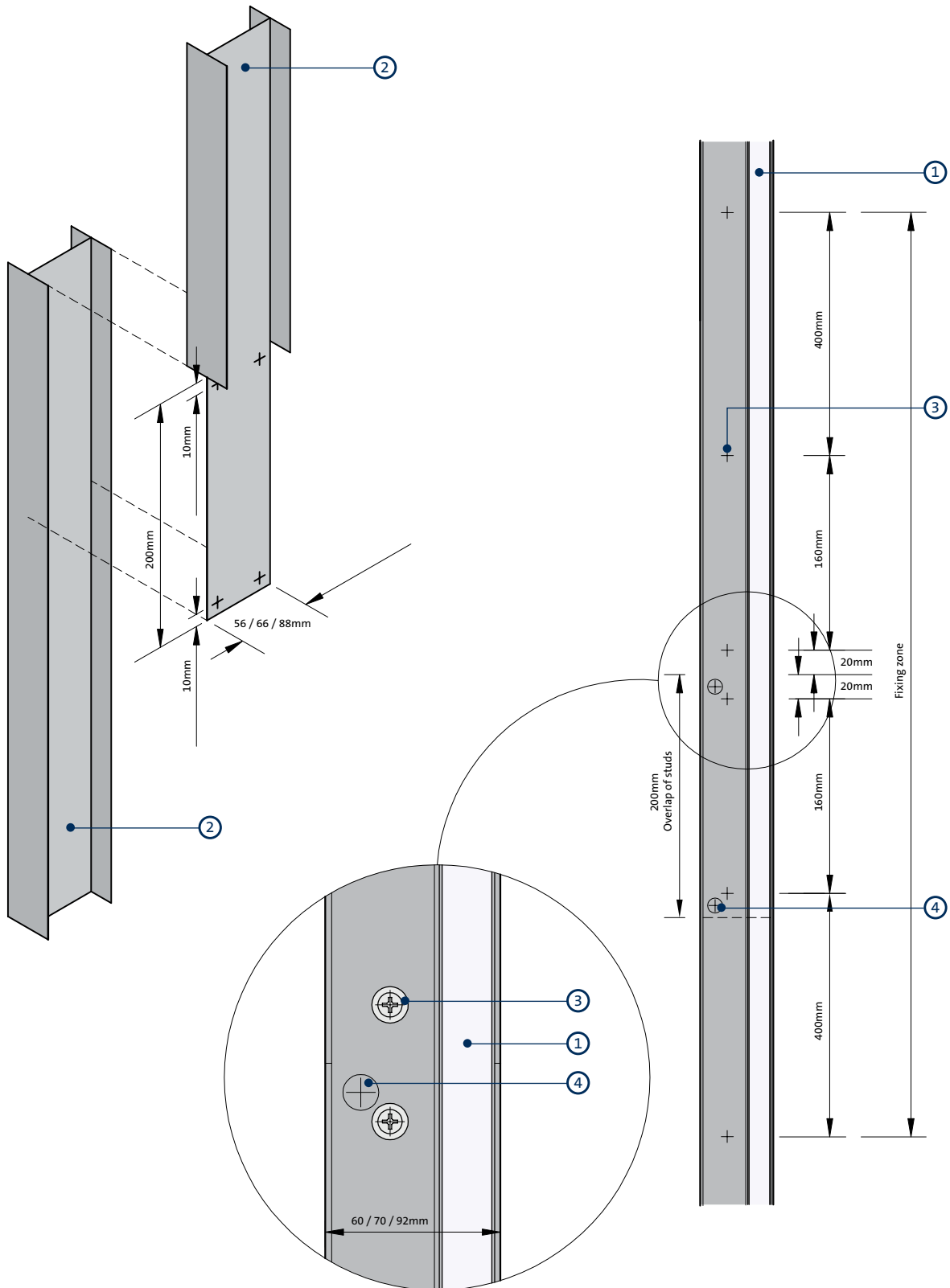

60 / 70 / 92mm T Stud splicing detail

- 1 Gyproc CoreBoard
- 2 Gypframe T Stud

- 3 Gyproc Wafer Head Jack-Point Screw
- 4 14mm dia. pre-drilled hole in Gypframe Retaining Channel to coincide and clear screws connecting overlap of T Studs

ShaftWall construction details (continued)

32

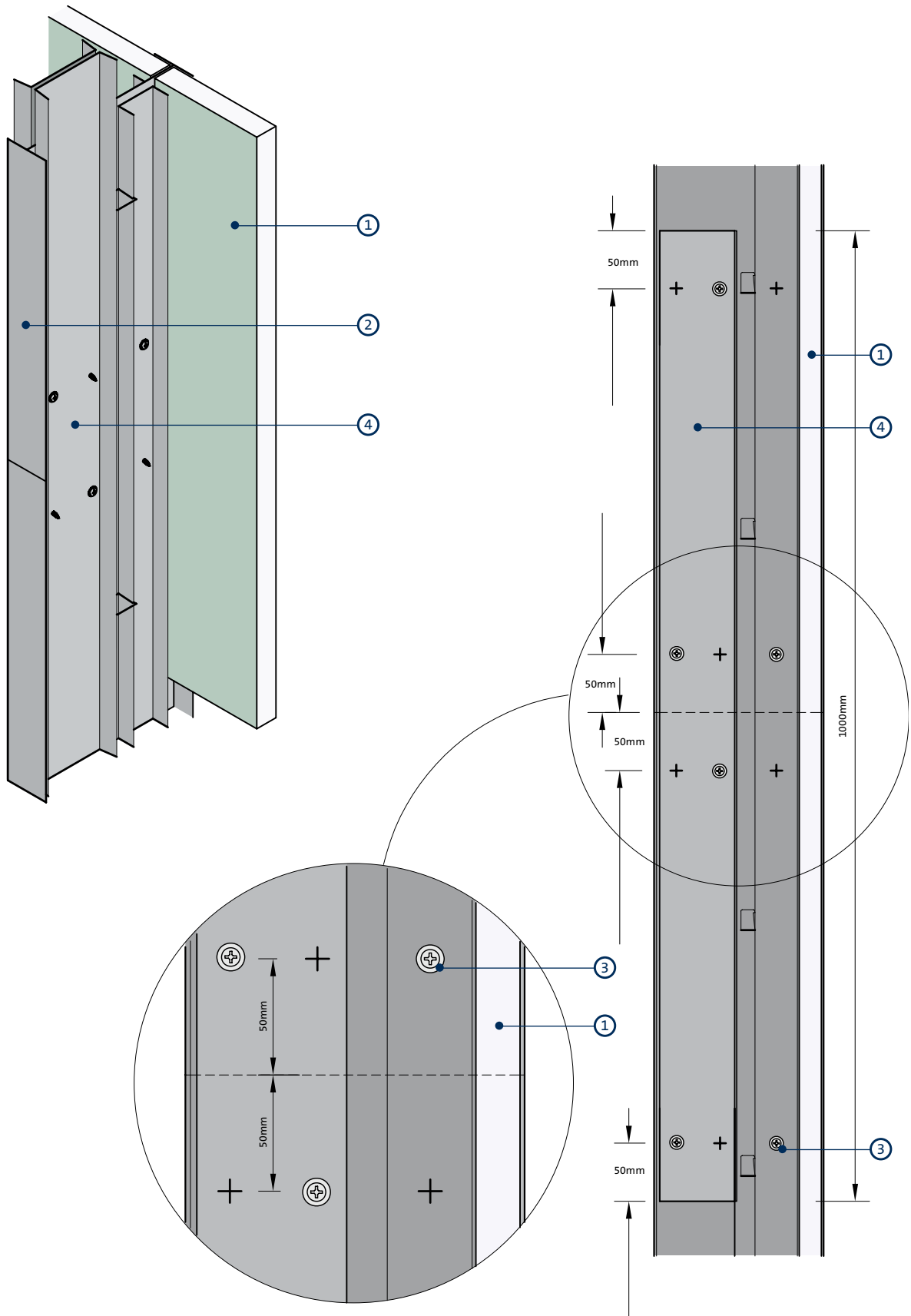

146mm T Stud splicing detail

- 1 Gyproc CoreBoard
- 2 Gypframe T Stud

- 3 Gyproc Wafer Head Jack-Point Screw
- 4 Gypframe G105 Retaining Channel

ShaftWall construction details (continued)

Horizontal ShaftWall (ShaftWall used horizontally should not be used for material storage or access for personnel)

33

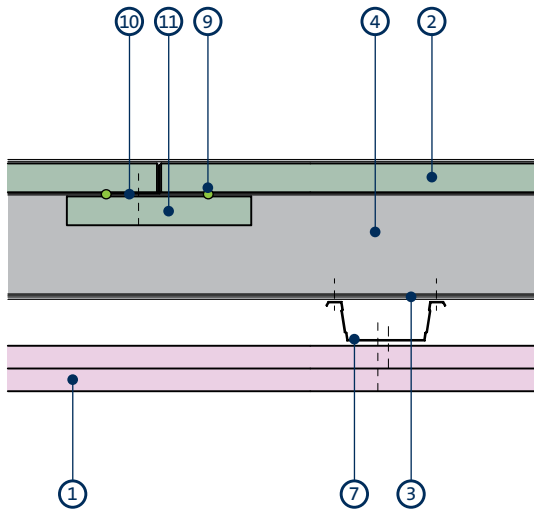

Gyproc CoreBoard joint

34

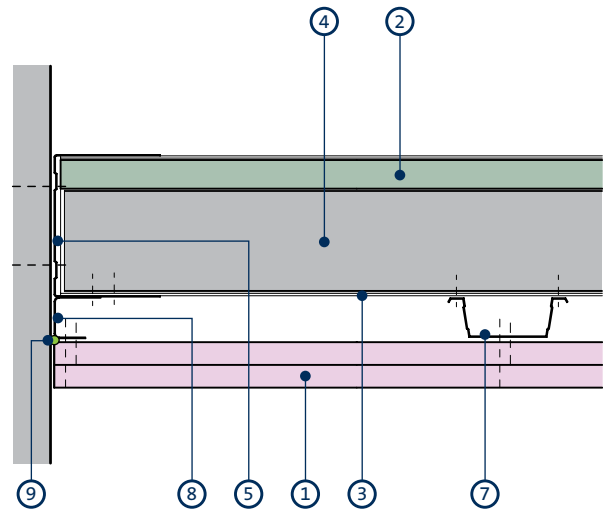

Perimeter detail 1

35

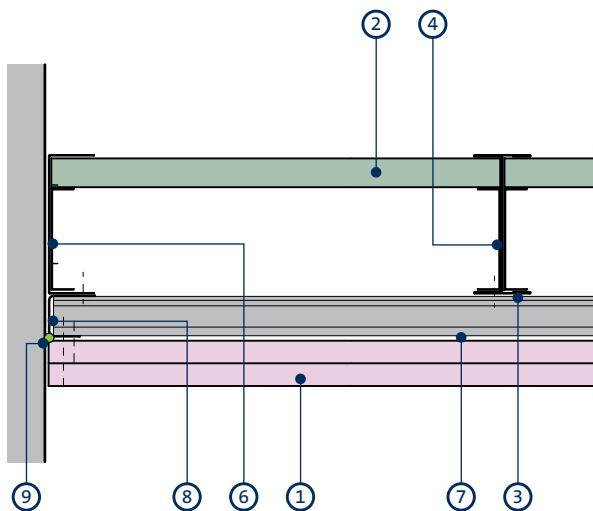

Perimeter detail 2

- | | |
|--|---|
| <ul style="list-style-type: none"> 1 Gyproc FireLine 2 Gyproc CoreBoard 3 Gyframe 'T' Stud 4 Gyframe Retaining Channel 5 Gyframe Extra Deep Flange Floor & Ceiling Channel or Gyframe 'J' Channel | <ul style="list-style-type: none"> 6 Gyframe Starter Channel 7 Gyframe MF5 Ceiling Section 8 Gyframe MF6 Perimeter Channel 9 Gyproc Sealant 10 Gyframe GA3 Steel Angle 11 122mm wide strip of 19mm Gyproc CoreBoard |
|--|---|

ShaftWall construction details (continued)

Horizontal ShaftWall (ShaftWall used horizontally should not be used for material storage or access for personnel)

36

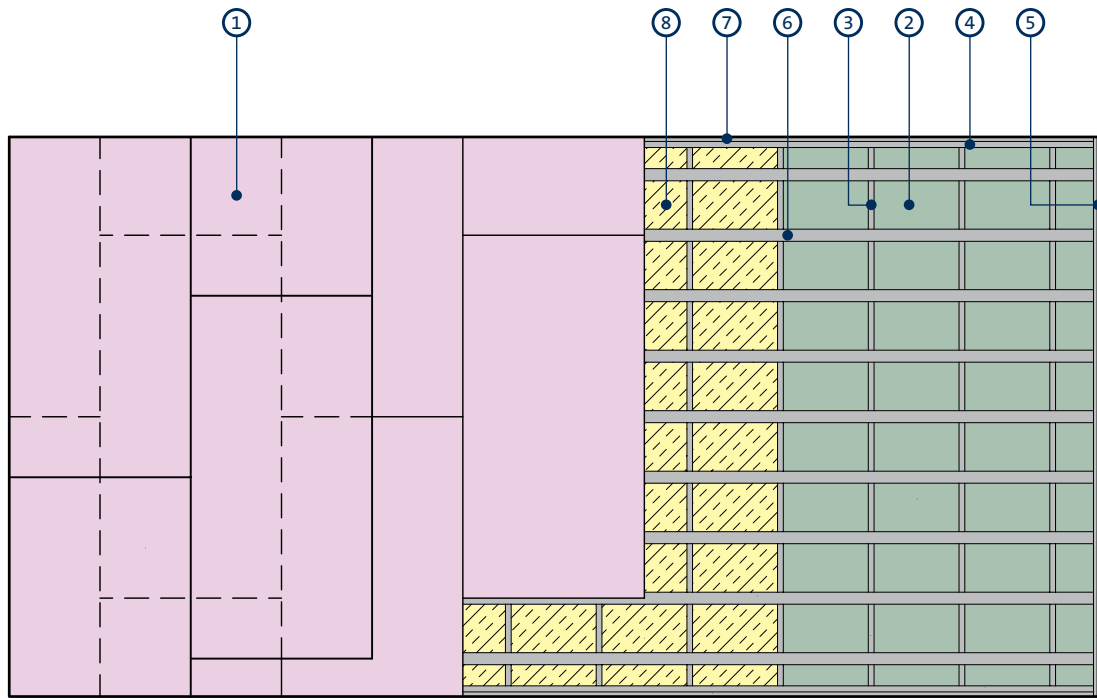

Reflected ceiling

- 1 Gyproc FireLine
- 2 Gyproc CoreBoard
- 3 Gyframe 'T' Stud
- 4 Gyframe Extra Deep Flange Floor & Ceiling Channel or Gyframe 'J' Channel

- 5 Gypframe Starter Channel
- 6 Gypframe MF5 Ceiling Section
- 7 Gypframe MF6 Perimeter Channel
- 8 Isover Acoustic Insulation

Gypframe metal components

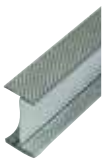

Gypframe 'I' Studs (60 I 70, 70 I 70, 92 I 90, 146 TI 90 Tabbed)

Enhanced strength stud that allows for partition height, without increasing partition width. Designed to receive fixing of board to one side (face fixed) and to accommodate Gyproc CoreBoard within its flange.



Gypframe Retaining Channel (G102, G105, G110)

Insert channel to provide support for the Gyproc CoreBoard located within the Gypframe 'I' stud. G102 for 60 I 70 and 146 TI 90 'I' Studs. G105 for 92 I 90 'I' Studs. G110 for 70 I 70 'I' Studs.

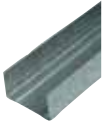

Gypframe Folded Edge Standard Floor & Ceiling Channels (62 FEC 50, 72 FEC 50, 94 FEC 50, 148 FEC 50)

Standard floor channels for retaining the Gypframe studs at floor junctions for heights not exceeding 4200mm.



Gypframe Retaining Clips (G108, G109)

Used within Gypframe 'I' studs at deflection heads. G108 for 92 I 90 'I' Studs. G109 for 146 TI 90 'I' Studs.

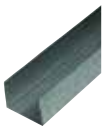

Gypframe Deep Flange Floor & Ceiling Channels (62 DC 60, 72 DC 60, 94 DC 60, 148 DC 60)

Floor and ceiling channels with deep flanges for retaining the Gypframe studs at floor and ceiling junctions for partitions 4200mm to 8000mm high. Also used around openings and in deflection heads (maximum 30mm deflection). Also accommodates Gypframe Retaining Clips / Channels and where applicable used around the perimeter in horizontal applications.



Gypframe GA3 Steel Angle

Steel angle providing framing stability and board support. Used at horizontal joints of Gyproc CoreBoard.



Gypframe 99 FC 50 Fixing Channel

A versatile metal fixing channel used to support medium weight fixtures on walls.



Gypframe 'J' Channel (62 JC 70)

Channels with uneven flanges for retaining the Gypframe studs at ceiling junctions. Also used around openings and in deflection heads.



Gypframe GFS1 Fixing Strap

Used to support horizontal board joints.

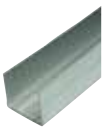

Gypframe Extra Deep Flange Floor & Ceiling Channels (72 EDC 80, 94 EDC 70, 148 EDC 80)

Floor and ceiling channels with extra deep flanges for retaining the Gypframe studs at floor and ceiling junctions for partitions over 8000mm high. Also used around openings and in deflection heads (maximum 50mm deflection). Also accommodates Gypframe Retaining Clips / Channels and where applicable used around the perimeter in horizontal applications.

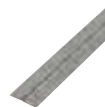

Gypframe GFT1 Fixing T

Used to support horizontal board joints.

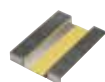

Gypframe Service Support Plate

For installation of 18mm plywood within a partition cavity to support medium to heavyweight fixtures.

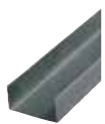

Gypframe Starter Channels (60 SC 50 at 3600mm, 70 SC 70 at 3600mm or 4200mm, 92 SC 90 at 5000mm or 6000mm)

Vertical stud used at abutments and openings to receive fixing of board.

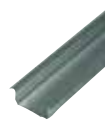

Gypframe MF5 Ceiling Section

Secondary section to support fixing of board.

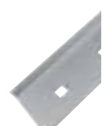

Gypframe Tabbed Starter Channel (146 TSC 90)

Vertical stud used at abutments and openings to receive fixing of board.



Gypframe MF6 Perimeter Channel

Perimeter section to support Gypframe MF5 Ceiling Section and fixing of board.

ShaftWall system components (continued)

Board products



Gyproc FireLine²

Gypsum plasterboard with fire resistant additives.



Gyproc DuraLine²

Gypsum plasterboard with fire resistant additives and a high density core for enhanced sound insulation and impact resistance performance.



Gyproc CoreBoard

Gypsum plasterboard with fire and moisture resistant additives. Retained within studs and to form deflection head.



Glasroc F FIRECASE¹

Non-combustible glass-reinforced gypsum board. Also used to form deflection head.

¹ Glasroc F FIRECASE boards used to replace Gyproc CoreBoard on the shaft side of the system must be cut to 598mm wide (+0mm / -3mm).

² Also available in a Moisture Resistant (MR) version. MR boards are specified in intermittent wet use areas.

Fixing products



Gyproc Drywall Screws

Corrosion resistant self-tapping steel screws for fixing board-to-timber and board-to-metal framing less than 0.8mm thick ('I' Studs less than 0.6mm thick).



Gyproc Jack-Point Screws

Corrosion resistant self-tapping steel screws for fixing board to metal framing 0.8mm thick and greater ('I' Studs 0.6mm thick and greater).



Gyproc Collated Drywall Screws

Corrosion resistant self-tapping steel screws for fixing board-to-timber and board-to-metal framing less than 0.8mm thick ('I' Studs less than 0.6mm thick).



Gyproc Wafer Head Jack-Point Screws

Corrosion resistant self-tapping steel screws for fixing metal to metal framing 0.8mm thick and greater ('I' Studs 0.6mm thick and greater).



Gyproc Wafer Head Drywall Screws

Corrosion resistant self-tapping steel screws for fixing metal to metal framing less than 0.8mm thick ('I' Studs less than 0.6mm thick).

Plasterboard accessories



Gyproc Jointing Materials

Jointing compounds, ready mixes and adhesives for reinforcement and finishing of board joints.



Gyproc edge and angle beads

Protecting and enhancing board edges and corners.



Gyproc FireStrip

A soft extruded linear intumescent gap sealer to maintain fire resistance located directly to the underside of the soffit when forming a deflection head.



Gyproc Sealant

Used to seal air paths for optimum sound insulation.



Gyproc Corner Tape

A paper tape bonded to two corrosion resistant steel strips.



Gyproc Paper Joint Tape

A paper tape designed for reinforcement of flat joints or internal angles.



Gyproc Drywall Primer

Used to prepare for painting. Tub contents 10 litre.



Gyproc Drywall Sealer

Used to provide vapour control. Tub contents 10 litre.

ShaftWall system components (continued)

Finishing products

**Gyproc Skimcoat**

To provide a plaster skim finish on most common backgrounds including undercoat plasters and plasterboard.

**Gyproc Carlite Finish**

To provide a plaster skim finish on most common backgrounds including undercoat plasters and plasterboard.

**Gyproc Carlite Ultra Finish**

Offers all the benefits of Gyproc Skimcoat and Gyproc Carlite Finish with a reduced set time of 90-120mins, making it ideal for smaller jobs.

**Plaster accessories**

Designed for the reinforcement and finishing of board joints before plaster skimming.

Insulation products

**Isover Acoustic Roll**

Glass mineral wool for enhanced acoustic and thermal performance.

ShaftWall installation overview

This is intended to be a basic description of how the system is built.
For detailed installation guidance refer to the [Gyproc Installation Guide](#).



The appropriate Gyproframe channels, are suitably fixed to the floor and soffit of the structure. Gyproc FireStrip is used on the channel at the soffit.



Gyproframe Starter Channels are suitably fixed to vertical abutments. The perimeter of the partition is sealed with Gyproc Sealant.



Gyproframe 'I' Studs or Gyproframe Tabbed 'I' Studs are friction fitted into the channels at 600mm required centres. Gyproc CoreBoard or 20mm Glasroc F FIRECASE is fitted between the studs on the shaft side, and held in place with appropriate Gyproframe Retaining Channels. Door openings are formed to the ShaftWall Access Door Details.



Pressurised shafts and service ducts are sealed using Gyproc Sealant. This is applied to all board-to-metal junctions.

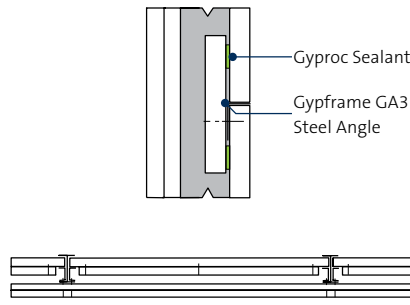

Horizontal board joints are fire stopped using Gyproframe GA3 Angle and strips of Gyproc CoreBoard from the non-shaft side.



Isover Acoustic Roll can be added to the partition cavity for increased acoustic performance.



Gyproc plasterboard or Glasroc F FIRECASE are then fixed to the Gyproframe framework with Gyproc Drywall Screws or Gyproc Jack-Point Screws.



Additional information

For full installation details, refer to the [Gyproc Installation Guide](#), available to download from gyproc.ie

