

INTRODUCTION

Materials used in aircraft construction have changed significantly since the Wright brothers built the first practical airplane. The Wright Flyer was constructed from wood and fabric, as were most early aircraft. Later, to increase strength and durability, manufacturers replaced wood substructures with welded steel tubing. However, metallic materials such as aluminum and stainless steel were eventually used not only in the substructure, but also as the outer covering. Today, most aircraft are primarily fabricated from metallic components, although advanced composite materials are being widely used mostly on control surfaces and nonstructural components. In the future, composite materials will constitute a greater percentage of an aircraft's structure, but metallic materials will certainly continue to be used for many years. This chapter serves as an introduction to the design, construction, inspection, and repair of basic airframe structures made from sheet metal. For detailed instructions regarding maintenance practices for specific airframe components, refer to the manufacturer's publications such as the maintenance manual (MM) or structural repair manual (SRM).

SECTION METALLIC AIRCRAFT CONSTRUCTION

A

During their career, nearly all aviation maintenance technicians are involved to some degree in the fabrication or repair of sheet metal aircraft structures. To fully understand the theories and procedures used in sheet metal work, a technician must recognize the construction techniques incorporated into the design of an airframe that allow it to handle different types of structural loads and stresses. In addition, a technician must also be aware of how different physical properties of sheet metal materials increase the durability and strength of an aircraft. With an understanding of these items, a technician can maintain an aircraft to its original condition, or properly alter its design to improve aircraft performance or safety.

STRESSES AND STRUCTURES

Aircraft structures must be strong, lightweight, streamlined, and durable. However, in most cases, all these requirements are unobtainable without compromise. Truss-type structures can be made both lightweight and strong; but with a resulting angular form, require a superstructure to make them streamlined. A wooden monocoque design does provide a streamlined form with high strength, but with compromises due to the limited useful life of wood, as well as the high cost involved with fabricating a laminated wood structure.

Today, the high volume of aircraft production has caused riveted or bonded sheet metal designs to become the most common method of construction. This is because sheet metal fabrication has been simplified over the years by developing and standardizing the tooling and equipment necessary for assembling most structures. Consequently, sheet metal aircraft are relatively easy to fabricate in a production facility as well as to repair in the field. [Figure 2-1]

The type of metal most widely used for aircraft structures comes from aluminum alloys, which account for as much as 90% of the metals used for

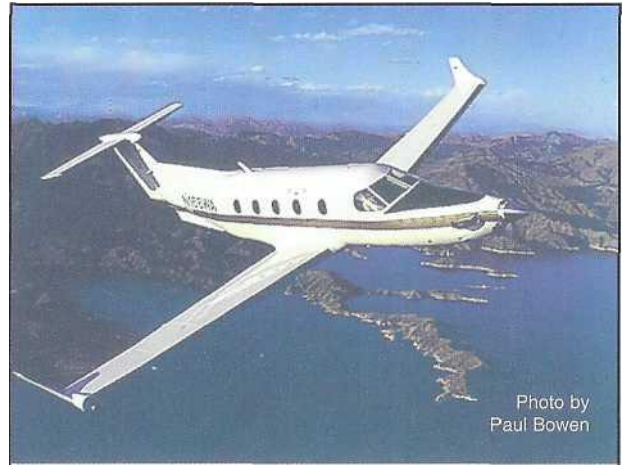

Figure 2-1. Modern sheet metal construction techniques produce airplanes that are strong, streamlined, and economical to assemble or repair.

civil aircraft. Heat-treated aluminum alloys have the advantage of being lightweight with the ability to carry high structural loads, while being comparably inexpensive with regard to other similar strength metals. These assets make aluminum alloy an excellent choice to use for the construction of most modern civil aircraft. The remaining 10% of metals used include titanium, stainless steel, and assorted exotic metals that are predominantly used on military or large transport category aircraft.

TYPES OF SHEET METAL STRUCTURES

There are two basic types of sheet metal structures used for aircraft; monocoque and semimonocoque. Both of these are forms of stressed skin structures, meaning that the greatest part of the load is carried in the external skin. However, these structures differ in the amount of internal components that they use. While both designs typically incorporate formers and bulkheads, a semimonocoque airframe also utilizes stringers and longerons to add rigidity and strength to the structure.

A thin metal beverage can is an excellent example of **monocoque** construction. The can has two thin

metal ends attached to an even thinner body, but as an assembly, can support a large load if a force is applied evenly across the ends of the container. However, a problem with a monocoque structure is that just a small dent or crease in a side wall can destroy its ability to support a load.

Semimonocoque structures minimize the problem of failures caused by dents and creases by supporting the external skin on a framework of formers, stringers, and longerons. The internal structure stiffens the skin so it is far less susceptible to failure caused by deformation. Because of its increased strength, a semimonocoque design is used in the construction of most modern aircraft.

Even the skin of an aircraft may be made more rigid across any large unsupported panels by riveting stiffeners or by laminating honeycomb material to the panels. Some modern high-speed jet aircraft have skins that are milled for increased rigidity. With these skins, stiffeners are formed on the inner surface by either conventional machining with a computer-controlled mill or by chemical or electrochemical milling.

STRUCTURAL LOADS

An airplane manufacturer must consider all of the loads to which the structure will be subjected in order to design each component properly. A safety factor is then built in to provide for any unusual or unanticipated loads that may conceivably be encountered. In addition to meeting all of the strength requirements, the structure must be as light-weight as possible and reasonably easy to construct.

As a maintenance technician it is your responsibility to be sure that any repair you make to an aircraft restores both the original strength and stiffness to the structure, while maintaining the original shape of the part. These considerations must be met while keeping the weight of the repair to an absolute minimum. In most cases of major structural damage, to guarantee that a repair meets minimum standards for strength, an aeronautical or structural engineer must develop and approve the design of the repair. These engineers have the credentials and experience to analyze the structural loads on the damaged area. From their analysis, these engineers can produce drawings and instructions that the technician must follow closely to accomplish a satisfactory repair. However, for some repairs, an aircraft technician can refer to the manufacturer's Structural Repair Manual or Maintenance Manual to determine if preapproved information is already avail-

able to meet FAA requirements. Even in cases where the damage is slight, it is permissible for a technician to use reference materials such as the Advisory Circular *AC 43.13-1B, Acceptable Methods, Techniques and Practices/Aircraft Inspection, Repair, and Alterations*. With this publication, acceptable procedures for performing some relatively common sheet metal repairs can be found. Although the advisory circular information is not FAA-approved data in itself, it can be used to substantiate an approved repair technique.

STRESSES

In order to determine that a repair will restore full strength to a damaged sheet metal structure, you should understand how various stresses act on an airframe. Five types of stress are of major concern. Two of these are primary, and the other three, for all practical purposes, can be expressed in terms of the first two. Tension and compression are the two basic stresses, and the other three, bending, torsion, and shear, are essentially different arrangements of tension and compression working on a body at the same time.

TENSION

Tension is a primary stress that tries to pull a body apart. When a weight is supported by a cable, the cable is subjected to tension or, as it is often expressed, to a tensile stress. The weight attempts to pull the cable apart. [Figure 2-2]

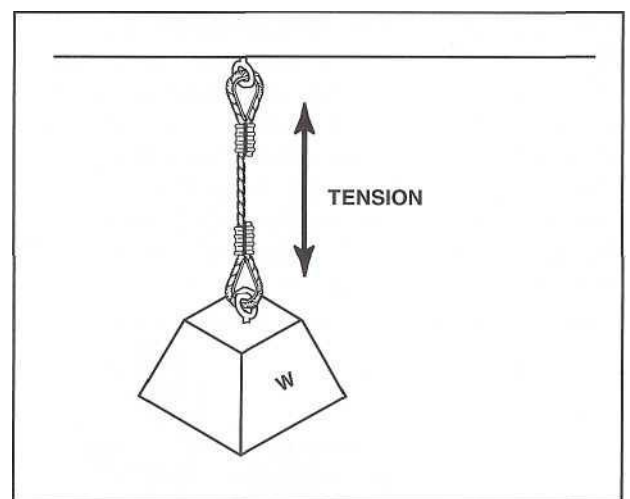

Figure 2-2. A tensile stress exerted on a cable tends to pull the cable apart.

COMPRESSION

Compression, another primary stress, tries to squeeze a part together. For example, a weight supported on a post exerts a force that tries to squeeze

the ends of the post together, or to collapse it. This is called a compressive stress. [Figure 2-3]

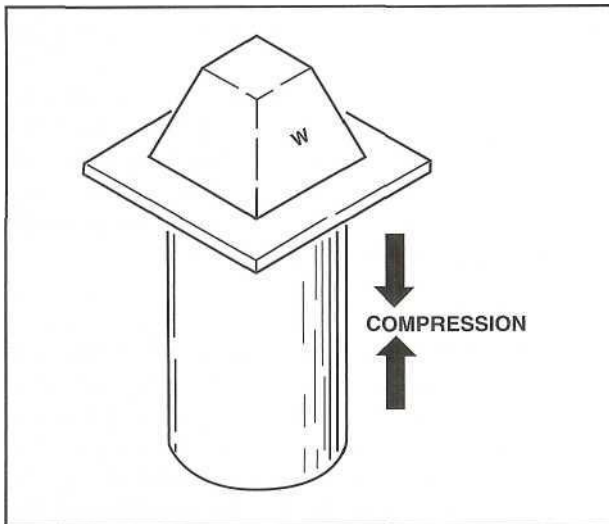

Figure 2-3. An example of a compressive stress is realized by analyzing the effect of a column that is supporting a weight. The weight tends to squeeze the ends of the column together.

BENDING

A bending force tries to pull one side of a body apart while at the same time squeezing the other side together. When a person stands on a diving board, the top of the board is under a tensile stress while the bottom is under compression. The wing spars of a cantilever wing or the section of a wing spar outboard of a strut is subjected to bending stresses. In flight, the top of a spar is being compressed while the bottom is under tension, but on the ground, the top is pulled and the bottom is compressed. Therefore, the major stresses imposed on wing struts reverse in flight as compared to on the ground. For this reason, it is important that spars be able to withstand both compressive and tensile stresses. [Figures 2-4 and 2-5]

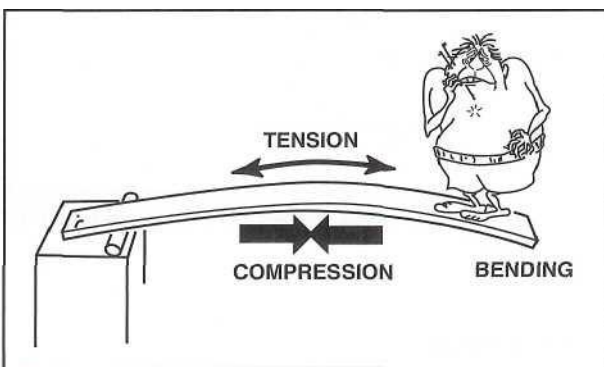

Figure 2-4. When a diving board is under a bending stress, tension stresses occur on the top of the board, while the bottom is under compression.

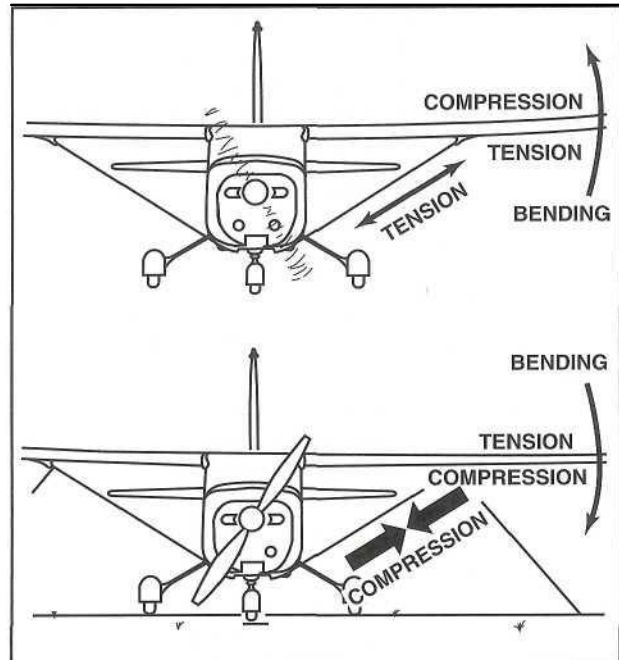

Figure 2-5. Wing struts are predominantly under tension in flight, but under compression when an airplane is on the ground. Outboard of a wing strut, the remaining portion of a wing is subjected to bending stresses.

TORSION

Torsion is a twisting force. When a structural member is twisted or placed under torsion, a tensile stress acts diagonally across the member and a compressive stress acts at right angles to the tension. For example, the crankshaft of an aircraft engine is under a torsional load when the engine rotates the propeller. [Figure 2-6]

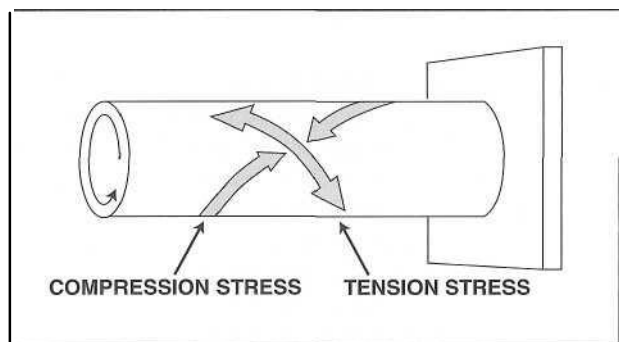

Figure 2-6. A torsional stress consists of tension and compression acting perpendicular to each other, with both acting diagonally across the body.

SHEAR

Shear loads are created when opposing forces are applied on opposite sides of a body. For example, a rivet is primarily designed to withstand shear loads from overlapping sheets of metal that are subjected to being pulled in opposite directions. Rivets hold

pieces of aircraft skin together, and in a properly designed joint, the rivets support more bearing or tensile load than shear load. [Figure 2-7]

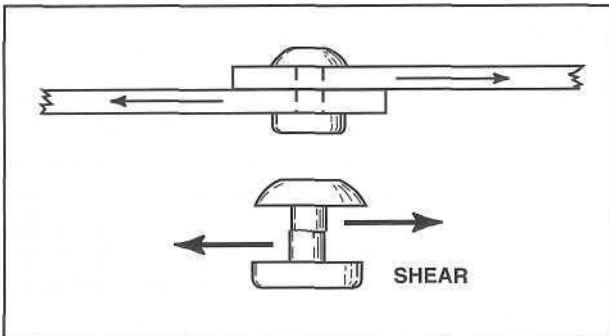

Figure 2-7. A shear stress on a rivet attempts to slide through the rivet shank.

RIVET JOINT CONSIDERATIONS

The design of an aircraft repair is complicated by the requirement that it be as lightweight as possible. If weight were not critical, all repairs could be made with a large margin of safety so there would never be a concern about the strength of the repair. However, in actual practice, repairs must be strong enough to carry all of the loads with the required safety factor, but also as lightweight as possible. On the other hand, a joint must also be manufactured in a way that if it is subjected to extreme loads, the fasteners will fail instead of the base metal. For these reasons, a joint that is too weak cannot be tolerated, but neither can one that is too strong.

BEARING STRENGTH

Bearing strength can be characterized by a sheet of metal being able to withstand being torn away from the rivets in a joint. The bearing strength of a material is affected by both its thickness and by the size of the rivet in the sheet. A joint is said to bear up when, for example, the landing gear makes contact with the runway upon landing and the wings droop downward (with the skins pulling against the rivets), and then springs back into normal position. The spring-back recovery results from the tensile stress produced by the bearing strength of the metal against the shear strength of the rivets. In other words, the joint is manufactured to have a certain amount of elasticity.

SHEAR VERSUS BEARING STRENGTH

Most aircraft structures are held together by the clamping action of either rivets or bolts. When fabricating a riveted joint, consider both the shear strength of the rivet (the amount of force that is needed to cut it in two) and the bearing strength of

the sheet metal (the amount of force that will cause the rivet to tear out from the metal). In a properly designed joint, the bearing strength and shear strength should be as near the same as possible, with the shear strength being slightly less. When this is provided, the joint will support the maximum load, but if it does fail, the rivet will shear. It is much less costly to replace a rivet than it is to repair a hole torn in the metal. [Figure 2-8]

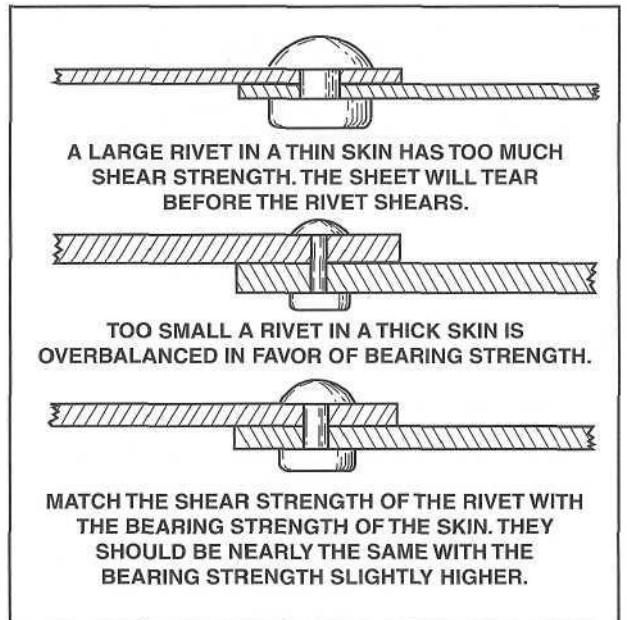

Figure 2-8. Rivet selection must be matched to skin thickness.

TRANSFER OF STRESSES WITHIN A STRUCTURE

An aircraft structure must be designed in such a way that it will accept all of the stresses imposed on it by flight or ground loads without any deformation. When repairs are made to the structure, they must be made to accept the stresses, carry them across the repair, and then transfer them back into the original structure. In this manner, the original integrity of the part is restored. [Figure 2-9]

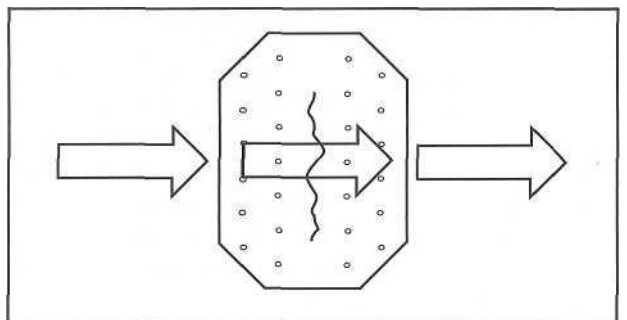

Figure 2-9. Any repair to an aircraft structure must accept all of the loads, support the loads, and then transfer them back into the structure.

Stresses can be thought of as flowing through a structure, so there must be a complete path for them to travel with no abrupt changes in the cross-sectional area along the way. Abrupt changes in area will cause the stresses to concentrate, and it is at such a point that failures occur. A scratch or gouge in the surface of a highly stressed piece of metal will obstruct the flow of stresses and concentrate them to the point that the metal will fail at the defect. [Figure 2-10]

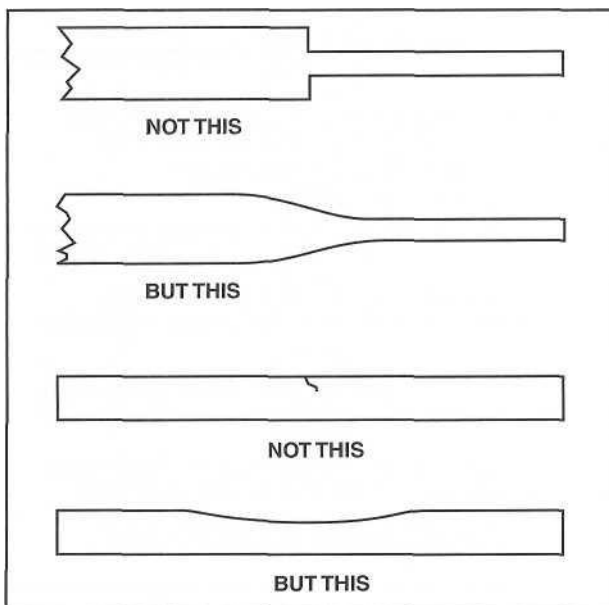

Figure 2-10. Abrupt changes in the cross-sectional area of a part must be avoided. An abrupt area change will concentrate the stresses and could cause the part to fail. To prevent gouges and scratches from becoming stress concentration points, burnishing is often accomplished. Burnishing involves using special tools called burnishing knives or spoons to taper and smooth the edges of the defect.

The thin metal that most aircraft structures are made of is subject to vibration and stresses, which in time, can cause cracks to form. These cracks may start out to be reasonably small, but if they form in the edge of a sheet that is being subjected to a tensile stress, the stresses will concentrate at the end of the crack. Eventually, the crack will propagate, causing the sheet to tear completely through. For example, if a small crack starts in the edge of a piece of 0.032 inch sheet aluminum alloy which has a tensile strength of 64,000 pounds per square inch (psi), it will take a stress of just over two pounds to extend the crack. Normal vibrations can produce stresses that far exceed this amount.

Metal thickness = .032 inch Width

at end of crack = .001 inch

Area subjected to tensile stress = .000032 sq. inches

Ultimate tensile strength of metal = 64,000 psi

Stress needed to cause the crack to extend = 2.048 pounds.

A standard fix for a crack developing in sheet metal is to stop-drill the end of the crack and rivet a patch over the entire damaged area. By drilling a hole with a number 30 bit at the end of the crack, the area on which the stresses concentrate increases from the .000032 sq. inches to .0129 sq. inches. This causes the stress needed to extend the crack to increase to about 819.2 pounds.

Diameter of number 30 drill = .128 inch

Circumference of number 30 drill = .402 inch Area subjected to tensile stress = .0129 sq. inches Stress needed to extend crack = 819.2 pounds.

To complete the repair, a small patch can be riveted over the crack to stiffen the edge of the material so the crack will not be subject to vibration. [Figure 2-11]

MATERIALS FOR SHEET METAL AIRCRAFT CONSTRUCTION

In Chapter Seven of the *A&P Technician General Textbook*, aircraft metal classifications and designations were discussed in detail. In this section, those metals used in the repair of aircraft structures are covered, including a brief review of the physical characteristics of these materials. By recognizing these characteristics, you will better understand how to select the ideal materials for a specific repair.

ALUMINUM ALLOYS

Pure aluminum lacks sufficient strength to be used for aircraft construction. However, its strength increases considerably when it is alloyed or mixed with other compatible metals. For example, when mixed with copper or zinc, the resultant aluminum alloy is as strong as steel, with only one-third the weight. Furthermore, the corrosion resistance possessed by the aluminum carries over to the newly formed alloy.

ALLOYING AGENTS

Aluminum alloys are classified by their major alloying ingredient. The elements most commonly used for aluminum alloying are copper, magnesium, manganese, and zinc. Wrought aluminum and wrought aluminum alloys are identified by a four-digit index system. The first digit of a designation

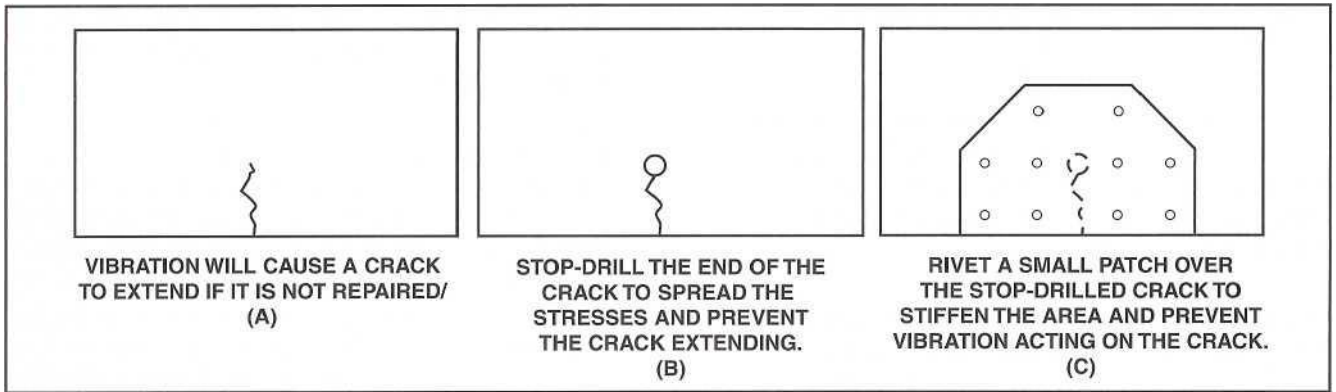

Figure 2-11. A crack in the edge of a sheet metal panel must be repaired to prevent the crack from expanding. However, cracks can also develop in the middle of a sheet due to large vibrations. For example, a common location for cracks to develop is ahead of control surfaces that are improperly balanced or that have extreme wear in the hinges. The air loads imposed on the control surface can cause it to aerodynamically flutter, generating extreme vibrations and stresses that are carried through the airframe structure. Eventually, the vibrations can cause cracks to form, which then expand at an accelerated rate.

identifies the major alloying element used in the formation of the alloy. The most common alloying elements used are as follows:

- 1xxx aluminum
- 2xxx copper
- 3xxx manganese
- 4xxx silicon
- 5xxx magnesium
- 6xxx magnesium and silicon
- 7xxx zinc
- 8xxx other elements

The second number represents a specific alloy modification. For example, if this digit is zero, it indicates there were no special controls over individual impurities. However, a digit of 1 through 9 indicates the number of controls over impurities in the metal.

The last two numbers of the 1xxx group of alloys are used to indicate the hundredths of 1% above the original 99% pure aluminum. For example, if the

last two digits are 75, the alloy contains 99.75% pure aluminum. However, in the 2xxx through 8xxx groups, the last two digits identify the different alloys in the group. [Figure 2-12]

The 1xxx series of aluminum alloys represents commercially pure aluminum, of 99% or higher purity. Pure aluminum offers high corrosion resistance, excellent thermal and electrical properties, and is easily worked. However, pure aluminum is very low in strength.

Alloys within the 2xxx series utilize **copper** as the principle alloying agent. When aluminum is mixed with copper, certain metallic changes take place in the resultant alloys grain structure. For the most part, these changes are beneficial and produce greater strength. However, a major drawback to aluminum-copper alloys is their susceptibility to inter-granular corrosion when improperly heat-treated. Most aluminum alloy used in aircraft structures is an aluminum-copper alloy. Two of the most com-

PERCENT OF ALLOYING ELEMENTS ALUMINUM AND NORMAL IMPURITIES CONSTITUTE REMAINDER							
ALLOY	COPPER	SILICON	MANGANESE	MAGNESIUM	ZINC	CHROMIUM	
1100							Seldom used in aircraft
3003			1.2				Cowling and non-structural parts
2017	4.0		0.5	0.5			Obsolete superseded by 2024
2117	2.5			0.3			Most aircraft rivets
2024	4.5		0.6	1.5			Majority of structure
5052				2.5		0.25	Gas tanks and fuel lines
7075	1.6			2.5	5.6	0.3	High strength requirements

Figure 2-12. A variety of elements are used to produce aluminum alloys.

monly used in the construction of skins and rivets are 2017 and 2024.

The 3xxx series alloys have **manganese** as the principle alloying element, and are generally considered nonheat treatable. The most common variation is 3003, which offers moderate strength and has good working characteristics.

The 4xxx series aluminum is alloyed with **silicon**, which lowers a metal's melting temperature. This results in an alloy that works well for welding and brazing.

Magnesium is used to produce the 5xxx series alloys. These alloys possess good welding and corrosion-resistance characteristics. However, if the metal is exposed to high temperatures or excessive cold-working, its susceptibility to corrosion increases.

If silicon and magnesium are added to aluminum, the resultant alloy carries a 6xxx series designation. In these alloys, the silicon and magnesium form magnesium silicide, which makes the alloy heat treatable. Furthermore, the 6xxx series has medium strength with good forming and corrosion-resistance properties.

When parts require more strength and little forming, harder aluminum alloys are employed. The 7xxx series aluminum alloys are made harder and stronger by the addition of **zinc**. Some widely used forms of zinc-aluminum alloys are 7075 and 7178. The aluminum-zinc alloy 7075 has a tensile strength of 77 thousand pounds per square inch (KSI) and a bearing strength of 139 KSI. However, the alloy is very hard and is difficult to bend. An even stronger zinc alloy is 7178, which has a tensile strength of 84 KSI and a bearing strength of 151 KSI.

CLAD ALUMINUM ALLOY

Most external aircraft surfaces are made of clad aluminum. **Alclad** consists of a pure aluminum coating rolled onto the surface of heat-treated aluminum alloy. The thickness of this coating is approximately 5% of the alloy's thickness on each side. For example, if an alclad sheet of aluminum is .040 inch thick, then 5%, or .002 inches of pure aluminum, is applied to each side. This results in an alloy thickness of .036 inch.

This clad surface greatly increases the corrosion resistance of an aluminum alloy. However, if it is penetrated, corrosive agents can attack the alloy within. For this reason, sheet metal should be pro-

tected from scratches and abrasions. In addition to providing a starting point for corrosion, abrasions create potential stress points.

HEAT TREATMENT

Heat treatment is a series of operations involving the heating and cooling of metals in their solid state. Its purpose is to make the metal more useful, serviceable, and safe for a definite purpose. By heat-treating, a metal can be made harder, stronger, and more resistant to impact. Heat-treating can also make a metal softer and more ductile. However, one heat-treating operation cannot produce all these characteristics. In fact, some properties are often improved at the expense of others. In being hardened, for example, a metal may become brittle.

All heat-treating processes are similar in that they involve the heating and cooling of metals. They differ, however, in the temperatures to which the metal is heated and the rate at which it is cooled.

There are two types of heat-treatments used on aluminum alloys. One is called solution heat-treatment, and the other is known as precipitation heat-treatment. Some alloys, such as 2017 and 2024, develop their full properties as a result of solution heat-treatment, followed by about four days of cooling, or **aging**, at room temperature. However, other alloys, such as 2014 and 7075, require both heat-treatments.

Solution Heat Treatment

When aluminum is alloyed with materials such as copper, magnesium, or zinc, the resultant alloys are much stronger than aluminum. To understand why this happens, it is necessary to examine the microscopic structure of aluminum. Pure aluminum has a molecular structure that is composed of weakly bonded aluminum atoms and, therefore, is extremely soft. Aluminum alloys, on the other hand, consist of a base metal of aluminum and an alloying element that is dispersed throughout the structure. In this configuration, when the aluminum alloy is subjected to stress, these alloying particles adhere to the aluminum molecules and resist deformation. However, special processes must be used to allow the base metal and alloy to mix properly. For example, when aluminum is alloyed with copper through conventional processes, approximately .5% of the copper dissolves, or mixes, with the aluminum. The remaining copper takes the form of the compound CuAl_2 . However, when the aluminum alloy is heated suffi-

ciently, the remaining copper enters the base metal and hardens the alloy.

The process of heating certain aluminum to allow the alloying element to mix with the base metal is called solution heat-treating. In this procedure, metal is heated in either a molten sodium or potassium nitrate bath or in a hot-air furnace to a temperature just below its melting point. The temperature is then held to within about plus or minus 10°F of this temperature and the base metal is soaked until the alloying element is uniform throughout. Once the metal has sufficiently soaked, it is removed from the furnace and cooled, or quenched. It is extremely important that no more than about 10 seconds elapse between removal of an alloy from the furnace and the quench. The reason for this is that when metal leaves the furnace and starts to cool, its alloying metals begin to precipitate out of the base metal. If this process is not stopped, large grains of alloy become suspended in the aluminum and weaken the alloy. Excessive precipitation also increases the likelihood of intergranular corrosion.

To help minimize the amount of alloying element that precipitates out of a base metal, a quenching medium is selected to ensure the proper cooling rate. For example, a water spray or bath provides the appropriate cooling rate for aluminum alloys. However, large forgings are typically quenched in hot water to minimize thermal shock that could cause cracking. Thin sheet metal normally warps and distorts when it is quenched, so it must be straightened immediately after it is removed from the quench. After the quench, all metals must be rinsed thoroughly, since the salt residue from the sodium or potassium nitrate bath can lead to corrosion if left on the alloy.

Precipitation Heat Treatment

Heat-treatable aluminum alloys are comparatively soft when first removed from a quench. With time, however, the metal becomes hard and gains strength. When an alloy is allowed to cool at room temperature, it is referred to as **natural** aging and can take several hours or several weeks. For example, aluminum alloyed with copper gains about 90% of its strength in the first half-hour after it is removed from the quench, and becomes fully hard in about four or five days.

Alloy aging times can be lengthened, or shortened. For example, the aging process can be slowed by storing a metal at a subfreezing temperature imme-

diately after it is removed from the quench. On the other hand, reheating a metal and allowing it to soak for a specified period can accelerate the aging process. This type of aging is referred to as **artificial aging**, or **precipitation heat treatment**, and develops hardness, strength, and corrosion resistance by locking a metal's grain structure together.

Naturally aged alloys, such as the copper-zinc-magnesium alloys, derive their full strength at room temperature in a relatively short period and require no further heat-treatment. However, other alloys, particularly those with a high zinc content, need thermal treatment to develop full strength. These alloys are called artificially aged alloys.

Annealing

Annealing is a process that softens a metal and decreases internal stress. In general, annealing is the opposite of hardening. To anneal an aluminum alloy, the metal temperature is raised to an annealing point and held there until the metal becomes thoroughly heat soaked. It is then cooled to 500°F at a rate of about 50°F per hour. Below 500°F, the rate of cooling is not important.

When annealing clad aluminum metals, they should be heated as quickly and as carefully as possible. The reason for this is that if clad aluminum is exposed to excessive heat, some of the core material tends to mix with the cladding. This reduces the corrosion resistance of the metal. [Figure 2-13]

Heat-Treatment Identification

Heat-treatable alloys have their hardness condition designated by the letter "T", followed by one or more

ALLOY	ANNEALING TREATMENT		
	METAL TEMPERATURE °F	APPROX. TIME OF HEATING HOURS	TEMPER DESIGNATION
1100	550		-0
2017	775	2-3	-0
2024	775	2-3	-0
2117	775	2-3	-0
3003	775		-0
5052	650		-0
6061	775	2-3	-0
7075	775	2-3	-0

Figure 2-13. Aluminum alloys are heat-treated to increase their strength and improve their working characteristics. Heat-treatment temperatures and soak times are critical to disperse the alloying elements.

numbers. A listing of the more popular temper designation codes includes the following: [Figure 2-14]

HEAT-TREATABLE ALLOYS	
TEMPER DESIGNATION	DEFINITION
-0	Annealed recrystallized (wrought products only) applies to softest temper of wrought products.
-T3	Solution heat-treated and cold-worked by the flattening or straightening operation.
-T36	Solution heat-treated and cold-worked by reduction of 6 percent.
-T4	Solution heat-treated.
-T42	Solution heat-treated and aged by user regardless of prior temper (applicable only to 2014 and 2024 alloys).
-T5	Artificially aged only (castings only).
-T6	Solution heat-treated and artificially aged.
-T62	Solution heat-treated and aged by user regardless of prior temper (applicable only to 2014 and 2024 alloys).
-T351.-T451	Solution heat-treated and stress
-T3510,-T3511 -T4510,-T4511	relieved by stretching to produce a permanent set 1 to 3 percent, and depending on product.
-T651.-T851 -T6510.-T8510 -T6511,-T8511	Solution heat-treated and stress relieved by stretching to produce a permanent set 1 to 3 percent, and artificially aged.
-T652	Solution heat-treated, compressed to produce a permanent set and then artificially aged.
-T81	Solution heat-treated, cold-worked by the flattening or straightening operation, and then artificially aged.
-T86	Solution heat-treated, cold-worked by reduction of 6 percent, and then artificially aged.
-F	For wrought alloys, as fabricated. No mechanical properties limits. For cast alloys, as cast.

Figure 2-14. All heat treatment processes are identified from the manufacturer by the use of a standardized temper designation number.

Reheat-Treatment

Material which has been previously heat treated can generally be reheat-treated any number of times. As an example, rivets made of 2017 or 2024 are

extremely hard and typically receive several reheat-treatments to make them soft enough to drive. However, the number of solution heat-treatments allowed for clad materials is limited due to the increased diffusion of core material into the cladding. This diffusion results in decreased corrosion resistance. As a result, clad material is generally limited to no more than three reheat-treatments.

NONHEAT-TREATABLE ALLOYS

Commercially pure aluminum does not benefit from heat treatment since there are no alloying materials in its structure. By the same token, 3003 is an almost identical metal and, except for a small amount of manganese, does not benefit from being heat treated. Both of these metals are lightweight and somewhat corrosion resistant. However, neither has a great deal of strength and, therefore, their use in aircraft is limited to nonstructural components such as fairings and streamlined enclosures that carry little or no load.

Alloy 5052 is perhaps the most important of the nonheat-treatable aluminum alloys. It contains about 2.5% magnesium and a small amount of chromium. It is used for welded parts such as gasoline or oil tanks, and for rigid fluid lines. Cold working increases its strength.

STRAIN-HARDENING AND HARDNESS DESIGNATIONS

Both heat-treatable and non-heat-treatable aluminum alloys can be strengthened and hardened through strain hardening, also referred to as cold working or work hardening. This process requires mechanically working a metal at a temperature below its critical range. Strain hardening alters the grain structure and hardens the metal. The mechanical working can consist of rolling, drawing, or pressing.

Heat-treatable alloys have their strength increased by rolling after they have been solution heat treated. On the other hand, non-heat-treatable alloys are hardened in the manufacturing process when they are rolled to their desired dimensions. However, at times these alloys are hardened too much, and must be partially annealed.

Where appropriate, the metal hardness, or temper, is indicated by a letter designation that is separated from the alloy designation by a dash. When the basic temper designation must be more specifically defined one or more numbers follow the letter designation. These designations are as follows:

- F For wrought alloys; As fabricated. No mechanical property limits. For cast alloys; As cast.
- O Annealed, recrystallized (wrought materials only); Applies to softest temper of wrought products.
- Ff Strain hardened.
- Hi Strain hardened only. Applies to products which are strain hardened to obtain the desired strength without supplementary thermal treatment.
- H2 Strain hardened and partially annealed.
- H3 Strain hardened and stabilized.

When a digit follows the designations HI, H2, or H3, the second number indicates the degree of strain hardening. For example, the number 8 in the designation H18 represents the maximum tensile strength, while in H10, the 0 indicates an annealed state. The most common designations include:

- Hx2 Quarter-hard
- Hx4 Half-hard
- Hx6 Three-quarter hard
- Hx8 Full-hard

MAGNESIUM AND ITS ALLOYS

Magnesium alloys are used for castings, and in their wrought form, are available in sheets, bars, tubing, and extrusions. Magnesium is one of the lightest metals having sufficient strength and suitable working characteristics for use in aircraft structures. It has a density of 1.74, compared with 2.69 for aluminum. In other words, it weighs only about 2/3 as much as aluminum.

Magnesium is obtained primarily from electrolysis of sea water or brine from deep wells, and lacks sufficient strength in its pure state for use as a structural metal. However, when alloyed with zinc, aluminum, thorium, zirconium, or manganese, it develops strength characteristics that make it quite useful.

The American Society for Testing Materials (ASTM) has developed a classification system for magnesium alloys that consists of a series of letters and numbers to indicate alloying agents and temper condition. [Figure 2-15]

Magnesium has some rather serious drawbacks that have to be overcome before it can be used successfully. For example, magnesium is highly susceptible to corrosion, and tends to crack. The cracking con-

ALLOYING ELEMENTS	TEMPER CONDITION
A-ALUMINUM	F- AS FABRICATED
E - RARE EARTH	O- ANNEALED
H-THORIUM	H2 - STRAIN HARDENED AND 4 PARTIALLY ANNEALED
K-ZIRCONIUM	T4- - SOLUTION HEAT-TREATED
M - MANGANESE	T5- - ARTIFICIALLY AGED ONLY
Z-ZINC	T6- - SOLUTION HEAT-TREATED AND ARTIFICIALLY AGED

Figure 2-15. Magnesium alloys use a different designation system than aluminum. For example, the designation AZ31A-T4 identifies an alloy containing 3% aluminum and 1% zinc that has been solution heat-treated.

tributes to its difficulty in forming and limits its use for thin sheet metal parts. However, this tendency is largely overcome by forming parts while the metal is hot. Treating the surface with chemicals that form an oxide film to prevent oxygen from reaching the metal minimizes the corrosion problem. When oxygen is excluded from the surface, no corrosion can form. Another important step in minimizing corrosion is to always use hardware such as rivets, nuts, bolts, and screws that are made of a compatible material.

In addition to cracking and corroding easily, magnesium burns readily in a dust or small-particle form. For this reason, caution must be exercised when grinding and machining magnesium. If a fire should occur, extinguish it by smothering it with dry sand or some other dry material that excludes air from the metal and cools its surface. If water is used, it will only intensify the fire.

Solution heat-treatment of magnesium alloys increases tensile strength, ductility, and resistance to shock. After a piece of magnesium alloy has been solution heat-treated, it can be precipitation heat-treated by heating it to a temperature lower than that used for solution heat-treatment, and holding it at this temperature for a period of several hours. This increases the metal hardness and yield strength.

TITANIUM AND ITS ALLOYS

Titanium and its alloys are lightweight metals with very high strength. Pure titanium weighs .163 pounds per cubic inch, which is about 50% lighter than stainless steel, yet it is approximately equal in strength to iron. Furthermore, pure titanium is soft and ductile with a density between that of aluminum and iron.

Titanium is a metallic element which, when first discovered, was classified as a rare metal. However, in 1947 its status was changed due to its importance as a structural metal. In the area of structural metallurgy, it is said that no other structural metal has been studied so extensively or has advanced aircraft structures so rapidly.

In addition to their light weight and high strength, titanium and its alloys have excellent corrosion resistance characteristics, particularly to the corrosive effects of salt water. However, since the metal is sensitive to both nitrogen and oxygen, it must be converted to titanium dioxide with chlorine gas and a reducing agent before it can be used.

Titanium is classified as alpha, alpha-beta, or beta alloys. These classifications are based on specific chemical bonding within the alloy itself. The specifics of the chemical composition are not critical to working with the alloy, but certain details should be known about each classification.

Alpha alloys have medium strengths of 120 KSI to 150 KSI and good elevated-temperature strength. Because of this, alpha alloys can be welded and used in forgings. The standard identification number for alpha titanium is 8Al-1Mo-1V-Ti, which is also referred to as Ti-8-1-1. This series of numbers indicates that the alloying elements and their percentages are 8% aluminum, 1% molybdenum, and 1% vanadium.

Alpha-beta alloys are the most versatile of the titanium alloys. They have medium strength in the annealed condition and much higher strength when heat-treated. While this form of titanium is generally not weldable, it has good forming characteristics.

Beta alloys have medium strength, excellent forming characteristics, and contain large quantities of high-density alloying elements. Because of this,

beta titanium can be heat-treated to a very high strength.

The grain size of titanium is refined when aluminum is added to the alloy mixture. However, when copper is added to titanium, a precipitation-hardening alloy is produced. Titanium added to high temperature nickel-cobalt-chromium alloy produces a precipitation-hardening reaction, which provides strength at temperatures up to 1,500°F [Figure 2-16]

Because of its high strength-to-weight ratio, titanium is now used extensively in the civilian aerospace industry. Although once rare on commercial aircraft, alloys containing 10 to 15 percent titanium in structural areas are utilized on modern jet transports.

STAINLESS STEEL

Stainless steel is a classification of corrosion-resistant steels that contain large amounts of chromium and nickel. Their strength and resistance to corrosion make them well suited for high-temperature applications such as firewalls and exhaust system components. These steels can be divided into three general groups based on the chemical structure: austenitic, ferritic, and martensitic.

Austenitic steels, also referred to as 200 and 300 series stainless steels, contain a large percentage of chromium and nickel, and in the case of the 200 series, some manganese. When these steels are heated to a temperature above the critical range and held there, a structure known as austenite forms. Austenite is a solid solution of pearlite, an alloy of iron and carbon, and gamma iron, which is a non-magnetic form of iron. Only cold-working can harden austenitic stainless steels, while heat treatment serves only to anneal them.

Ferritic steels are primarily alloyed with chromium,

ALLOY	COMPOSITION	TENSILE STRENGTH	ELONGATION
ALPHA	5% AL - 2.5% SN	130 KSI	15%
ALPHA-BETA	6% AL - 4% V	140 KSI	15%
ALPHA-BETA HEAT-TREATED	6% AL - 4% V	180 KSI	7%
BETA	13% V - 11% CR - 3% AL	150 KSI	15%
BETA HEAT-TREATED	13% V - 11% CR - 3% AL	200 KSI	6%
DEFINITIONS OF LETTERS AND PERCENTAGES ARE: AL - ALUMINUM CR - CHROMIUM V - VANADIUM SN - TIN			

Figure 2-16. This table illustrates the composition, tensile strength, and elongation of titanium alloys. The degree of strength is denoted by the smaller hole elongation percentage shown in the last column. The titanium alloy most commonly used by the aerospace industry is an alpha-beta heat-treated alloy called 6Al-4V. This alloy has a tensile strength of 180 KSI, or 180,000 pounds per square inch. It is frequently used for special fasteners.

but many also contain small amounts of aluminum. However, they contain no carbon and, therefore, do not respond to heat-treatment.

The 400 series of stainless steel is a **martensitic steel**. These steels are alloyed with chromium only and therefore are magnetic. Martensitic steels become extremely hard if allowed to cool rapidly by quenching from an elevated temperature.

The corrosion-resistant steel most often used in aircraft construction is known as 18-8 steel because it contains 18% chromium and 8% nickel. One of the distinctive features of 18-8 steel is that cold-working may increase its strength.

ALUMINUM ALLOY-FACED HONEYCOMB

Very thin sheets of aluminum alloy may meet all of the strength requirements for an aircraft structure, but they may not provide enough rigidity or stiffness to withstand the rough handling to which the structure is subjected. To provide this rigidity, some wing skins, fuselage panels, and floorboards are made of aluminum alloy-faced honeycomb.

With aluminum alloy-faced honeycomb, a core material is made up of aluminum foil formed into a cellular structure similar in shape to that used by the honey bee. This form gives a maximum amount of strength for its weight, but it is strong only against loads that act in line with the cells. The core material is cut into slabs of the proper thickness, and face sheets of thin aluminum alloy are bonded to both sides of the core. This stabilizes the core and produces a panel whose strength is greater than both of the face sheets. It has the rigidity of a thick panel, but its weight is far less than that of a solid panel of similar dimensions, or of a panel built up by any other method. [Figure 2-17]

Repair of a simple puncture of an aluminum alloy-faced honeycomb panel can be accomplished by covering with a doubler plate. The plate should be cut from a piece of aluminum the same or up to one and one-half times the thickness of the original skin thickness. Additionally, the doubler should be tapered at a ratio of about 100:1. The repair of honeycomb panels is covered in the section on Aircraft Wood and Composite Structural Repair in Chapter Three, Wood and Composite Structures, in this text.

CORROSION PREVENTION OF SHEET METAL MATERIALS

As previously mentioned, the susceptibility of aluminum alloys to corrosion is one of the limiting factors as to its use as a structural material. In many

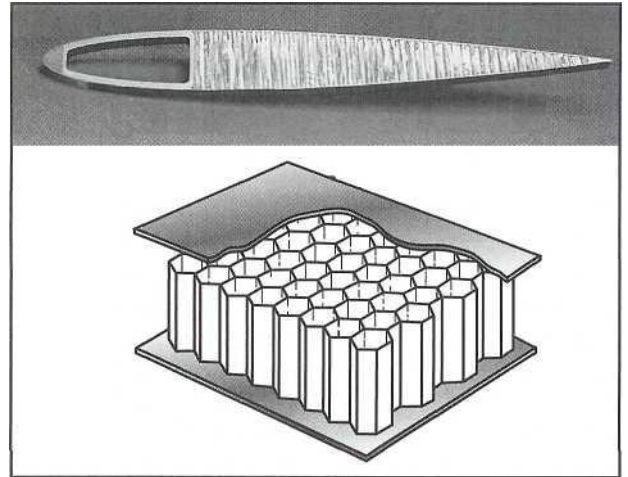

Figure 2-17. Aluminum alloy-faced honeycomb panels are used in aircraft where high strength, light weight, and stiffness are required. Bonded honeycomb is not restricted to straight panels, but may also be used to form complex-shaped control surfaces and is even used for the rotor blades of some helicopters.

cases, this problem has been largely minimized by three methods of protection. These methods are; cladding the alloy with pure aluminum, covering the surface with an impenetrable oxide film, and covering the surface with an organic coating such as primer and paint.

Before looking at each of these methods, a review of how corrosion forms will help you to understand what causes it and what can be done to prevent it. For a more thorough review, this information is covered in much more detail in Chapter Twelve of the *ASrP Technician General Textbook*.

Corrosion is an electrochemical action in which an element in the metal is changed into a porous salt of the metal. This salt is the white or gray powder that can be seen on a piece of corroded aluminum. In order for the corrosion to form, three elements must be met. First, there must be an area of electrode potential difference within the metal; second, there must be a conductive path within the metal between these areas; and third, some form of electrolyte must cover the surface between these areas to complete an electrical circuit.

Look at an example of dissimilar metal corrosion to see the way it works. When a steel bolt holds two pieces of aluminum alloy together, there is an opportunity for **galvanic**, or dissimilar metal, corrosion to form. Aluminum is more **anodic**, or more active, than steel and will furnish electrons for the electrical action that occurs when the surface is covered with an electrolyte such as water. When

electrons flow from the aluminum to the steel, they leave positive aluminum ions that attract negative hydroxide ions from the water. This results in the formation of aluminum hydroxide, or corrosion, as the aluminum is eaten away.

There are several things that can be done to prevent corrosion. You may have noticed that almost all steel aircraft hardware is plated with a thin coating of cadmium, which has an electrical potential almost the same as aluminum. As long as the cadmium is not scratched through, there will be no contact between the steel and the aluminum and therefore almost no electrode potential difference. To further protect the aluminum from damage, aluminum washers may be placed under both the head of the bolt and the nut, and as even further protection, if the joint is in a corrosive environment, the bolt can be dipped in primer before it is installed. This will exclude water and air from the joint, which will help prevent corrosion from forming. [Figure 2-18]

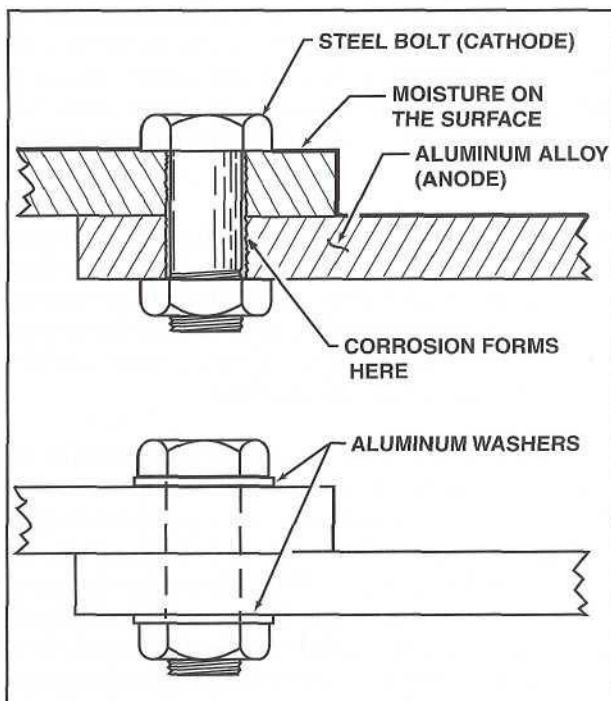

Figure 2-18. Corrosion may be prevented by excluding moisture from the metal and by preventing contact between dissimilar metals.

CLADDING

Pure aluminum will not corrode since there is no electrode potential difference within the metal, but it is too weak for use as an aircraft structural material. However, as previously mentioned, if a thin coating of pure aluminum is rolled onto the surface of the strong aluminum alloy, features of both, the pure

metal and the alloy, provide a strong and corrosion-resistant material. For this process, called cladding, there is a penalty by a loss of only about 5% of the strength of the alloy. To help determine if a metal sheet is clad or bare, aluminum alloy can be differentiated from pure aluminum by placing a drop of 10% solution, caustic soda (sodium hydroxide) on the surface. If it is an alloy, it will form a spot.

While pure aluminum does not corrode, it does oxidize; that is, it readily unites with oxygen in the air to form a dull-looking film on its surface. This film is extremely tight and prevents any more oxygen from reaching the metal, so the oxidizing action stops as soon as the film is completely formed on the surface. Clad aluminum may be used as the outside skin for airplanes since it gives a nice silvery appearance without being painted. Care must be taken, however, to prevent any scratches from penetrating through the thin cladding, as the alloy would then be exposed and would corrode. However, it is not unusual for corrosion to form along the edges where the alloy is exposed and between overlapping sheets. These joints are often referred to as fayed edges, and require additional protection. In many cases, fayed edges are sealed with a primer or epoxy filler to exclude moisture.

OXIDE FILM

An oxide film can protect aluminum alloy in the same way it protects pure aluminum; by excluding air and moisture from the metal. Since an aluminum alloy cannot corrode unless an electrolyte is in contact with the metal, the oxide film insulates the surface from the electrolyte, and corrosion cannot form. This protective oxide film may be formed either electrolytically or chemically. Both methods produce a film that not only excludes air from the surface, but also roughens it enough for paint to bond tightly.

PAINT FINISHES

When all-metal airplanes first became popular, they were seldom painted. Instead, the skin was usually of clad aluminum alloy, which had a shiny silver appearance. However, in order to keep the skin shiny, the dull oxide film had to continually be rubbed off, and since this type of surface requires so much care, the modern trend has become to paint the entire aircraft.

With a painted finish, the majority of modern high-volume production aircraft is primed with a two-part wash primer that etches the surface of the metal so paint will adhere. Then, when the primer is

completely cured, the entire airplane is sprayed with acrylic lacquer. However, when the cost of the finish allows it and when there is sufficient time in the production schedule, the surface may be primed

with epoxy primer and the aircraft finished with polyurethane enamel. These finishes are far more durable than acrylic lacquer and yield a much more attractive finish.

SECTION B

SHEET METAL TOOLS AND FASTENERS

Aircraft constructed from sheet metal require many specialized tools for fabricating the metal and for installing special fasteners. Due to the number of manufacturers of sheet metal equipment and fastener hardware, only a select few items are covered in this section. Continuous work as an aircraft technician, requires learning how to operate additional tools and how to install more types of fasteners. In all cases, refer and adhere to the appropriate manufacturer's instructions regarding the proper use of equipment and hardware that is used for aircraft maintenance.

FABRICATION TOOLS FOR SHEET METAL STRUCTURES

In Chapter 9 of the *A&P Technician General Textbook*, hand tools and measuring devices were discussed in detail. In this section, a review of some of the tools especially designed for sheet metal construction and repair is presented. First, a discussion regarding basic tool selection and operation for sheet metal construction will be covered, followed by an introduction to the use of specialized tools for specific sheet metal fabrications.

LAYOUT TOOLS

When a sheet metal repair is to be made, or a part is to be fabricated, a detailed drawing of the repair or part is sometimes available. For example, a drawing might be available from a structural repair manual. Other times, the technician must draw the repair from scratch, using guidance from a manual or from the FAA Advisory Circular, *AC 43.13-1B, Acceptable Methods, Techniques and Practices/Aircraft Inspection, Repair, and Alterations*. Whether the technician prepares a new drawing or transfers dimensions from a drawing for a pattern, layout tools are necessary to accurately determine dimensions.

SCALES

One of the most commonly used measuring devices for sheet metal layout is a flexible steel scale. These handy tools usually have four sets of graduations on them. For aircraft work, a scale with 32nds and

64ths of an inch on one side, and increments of 50ths and 100ths of an inch on the other, are most useful. For the greatest accuracy when using a scale, do not measure from its end. Instead, start with one of the inch marks. This is recommended because it is quite possible for a scale-end to have been damaged, resulting in an inaccurate measurement. [Figure 2-19]

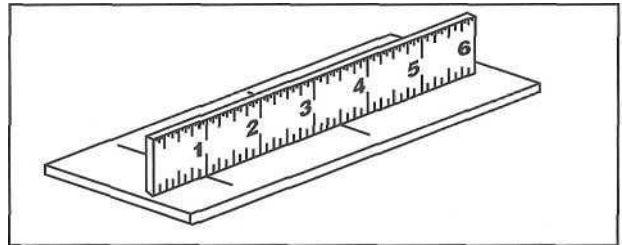

Figure 2-19. Do not make measurements from the end of a steel scale; rather, start with one of its inch marks.

COMBINATION SQUARE

A combination square is another extremely useful tool for sheet metal layout. The blade in this square is removable and is available with many different types of graduations. The blade with graduations of 50ths and 100ths of an inch is the most useful for aircraft layout work. The head of the square has a 45 degree bevel on one side and a 90 degree face on the other, with a spirit level and a steel scribe in the head. [Figure 2-20]

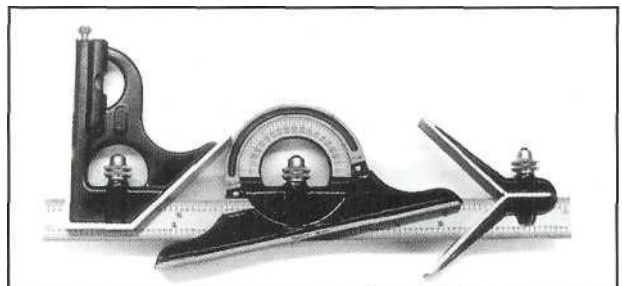

Figure 2-20. A combination square is one of the most useful measuring tools for sheet metal construction and repair. Aside from the stock head, which is commonly found on a combination set, a protractor and center head may be included.

DIVIDERS

A pair of good quality 6 inch spring dividers is essential for layout work. These tools are handy for spacing rivets in a row and for transferring distances when duplicating parts. They may also be used to transfer measurements from a full-scale drawing to a layout on an actual metal part. For example, if an inspection or a lightning hole is needed, dividers are used to scribe the outline of the hole onto the surface of the metal. Dividers are also used to make circles, arcs, and measurement transfers. [Figure 2-21]

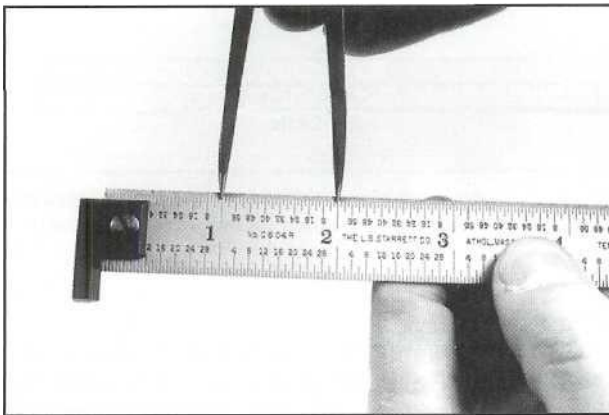

Figure 2-21. Dividers may be set from a steel scale and used to transfer measurements to the sheet metal.

MARKING TOOLS

Once a drawing has been selected, dimensions must be transferred to the surface of the metal for cutting, drilling, shaping, and forming. The marking device will vary according to the surface being marked and the operation to be performed on the sheet metal.

SCRIBES

In sheet metal fabrications, most work is done with soft metal so a carbide-tipped scribe is almost never needed. In many cases, the handiest scribe is made of plain steel and has a removable point that can be reversed in the handle so it will not be dulled by contacting other tools while stored in a toolbox. When using a scribe for marking sheet metal, a colored dye is usually applied to the metal beforehand, and the scribe is then used to scratch through the dye.

Scribes should be used in sheet metal work only for marking the cut-off lines of a part. They should never be used for marking dimension lines for bending metal. Any mark on a piece of sheet aluminum or magnesium that is scratched into the metal with a scribe can cause the part to crack when it is bent. [Figure 2-22]

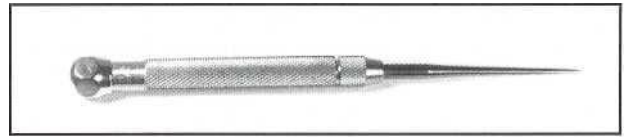

Figure 2-22. Steel scribes should be used only to mark the cut-off lines on sheet metal. As a result of scratches in soft sheet metal, stresses can concentrate from vibrations at the scratch, eventually causing the metal to crack. To prevent this from occurring, lines that will remain on the metal should be made with a soft felt tip marker, or soft pencil.

PENCILS

Most of the layout marks made on sheet metal can be made with a sharp, soft lead pencil. These marks can be more easily seen if the metal is wiped clean with lacquer thinner or toluol and then sprayed with a light coat of zinc chromate primer. The primer takes pencil marks very well, which show up without eyestrain. Since the film of the primer is generally so thin, it is not likely to interfere with accurate layout measurements and marks.

When using a lead pencil, use caution to avoid making any mark on the hot section of a turbine engine, or on the exhaust system of a reciprocating engine. When heated, these marks can cause the carbon from the pencil to infuse the metal, eventually causing the part to weaken and crack.

Common lead pencils can cause scratching while also inducing graphite into the material. To prevent this from occurring, use only pencils that are acceptable for sheet metal layout marking. Three examples of acceptable commercial pencils are **Stabilo "8008,"** **Dixon "Phano,"** and **Blaisdell.** These pencils are made of soft wax-charcoal, instead of graphite.

FELT MARKING PENS

Felt marking pens are becoming widely used by sheet metal technicians because their marks are more visible than those of other marking tools. To obtain sharp and clear lines, it is best to use a felt marking pen with a fresh, sharp tip. Once a part is fabricated, the lines made by the pen can be easily removed by wiping them with a rag soaked in alcohol.

PUNCHES

The lines drawn on sheet metal indicate where different operations such as bending and drilling are to be performed. This is not always sufficient for some operations. Drilling, for instance, requires some physical indentation on the surface in order to keep the drill from wandering when first starting. To

make indentations in metal, different types of punches are available for accurately transferring marks. Other types of punches are designed to impose forces on the metal without damaging adjacent areas.

PRICK PUNCH

Once layout marks have been made with a soft pencil, permanent marks can be made in locations for holes with a sharp prick punch. It takes only a light tap with a small hammer to mark these locations, which can be enlarged later with a center punch.

CENTER PUNCH

Enlarging a prick punch mark with a center punch allows a drill to be centered so that it will start cutting the metal in the proper location. The center punch has a blunt point, ground to an angle of about 60 degrees, which approximates the tip angle of a twist drill. The marks should be deep enough for the drill to start cutting, but the blow used on the punch must not be hard enough to distort the metal.

An automatic center punch is one of the handiest tools a sheet metal technician can have, allowing punch marks to be made quickly and uniformly. This punch is spring-loaded; all that is needed is to center it in the prick punch mark, and depress the punch. When the punch is pressed hard enough, a spring-loaded plunger inside the handle is released and hits the point with a solid blow. [Figure 2-23]



Figure 2-23. An automatic center punch makes uniform indentations for aligning tools such as drills and hole cutters.

TRANSFER PUNCH

Much sheet metal repair work consists of replacing damaged skin with new skins. If the old metal is in sufficient condition, layout marks can be transferred directly to the new material by the use of a transfer punch. A transfer punch is used to locate the exact center of drilled holes, such as those used for rivets. This punch has a shank the diameter of the hardware that will be installed in the hole, and has a sharp point in its exact center. The point will make a mark similar to a prick punch mark in the center of the hole. These punches are made as both solid steel, and automatic punches. [Figure 2-24]

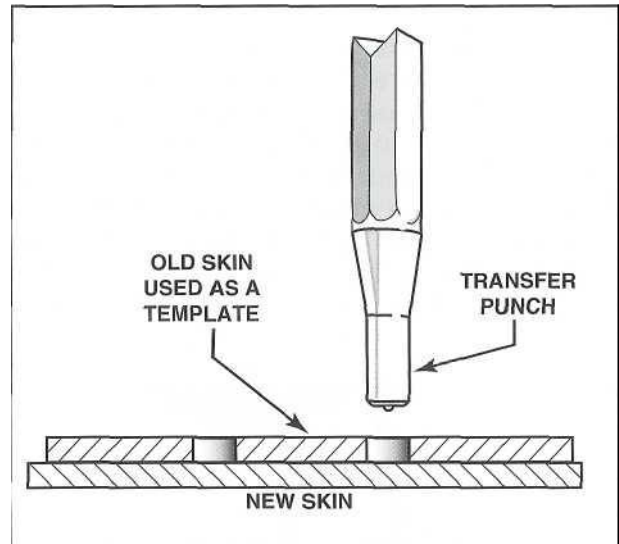

Figure 2-24. A transfer punch is primarily used to mark the center of rivet holes when using an old skin as a pattern.

PIN PUNCH

One of the most useful punches for a sheet metal worker is the pin punch because it is ideal for removing rivets. To do this, begin by drilling through the rivet head down to the base. Then, by using a pin punch of the same diameter as the rivet shank, snap the head off by prying sideways. Once the rivet head is removed, the rivet shank is then punched out of its hole with the pin punch, leaving the original-size rivet hole. When punching the rivet shanks out of thin materials, back up the metal before tapping the pin punch to help prevent distorting the metal. [Figure 2-25]

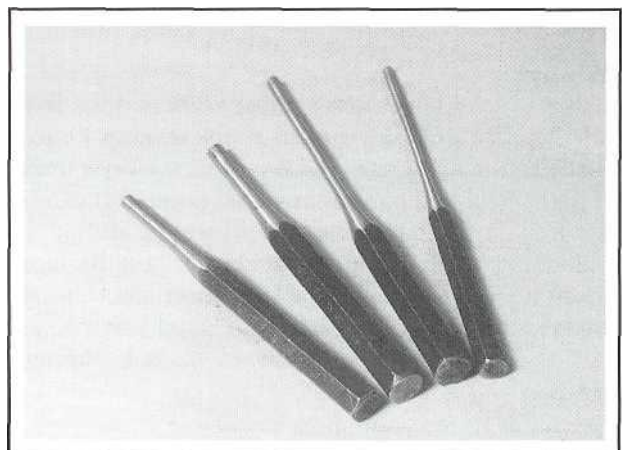

Figure 2-25. A pin punch has a flat tip and a uniform shank that is available in several different sizes.

Pin punches are available in sizes which correspond to standard rivet diameters. They range in sizes from 1/16 inch to 1/4 inch. The drill holes are

.002 inch to .004 inch larger than the pin punches. For example, a 1/8 inch (.125 inch) diameter rivet uses a No. 30 (.1285 inch) drill. The pin punch used would be the 1/8 inch size, easily fitting into the rivet hole with over a .003 inch clearance.

CUTTING TOOLS

Metal cutting tools can be divided into hand-operated or floor-mounted types. The list of these tools is rather lengthy. However, in this text, the ones most commonly used in the maintenance of aircraft will be covered. Again, when using any fabrication equipment, always consult the tool manufacturer's information for use and care instructions.

METAL-CUTTING POWER TOOLS

Many of the cutting operations done on sheet metal require the use of hand tools because the repair is done on the aircraft rather than being done on a workbench. Though most operations can be performed with non-powered hand tools, powered tools make the repair task go much faster and often much smoother.

Ketts Saw

The electrically operated portable circular-cutting Ketts saw uses blades of various diameters. The head of this saw can be turned to any desired angle, which makes it very useful for removing damaged sections on stringers and other intricately designed parts. Advantages of a Ketts saw include:

- The ability to cut metal up to 3/16 inch thick.
- A starting hole is not required.
- A cut can be started anywhere on a sheet of metal.
- The saw provides the capability to cut an inside or outside radius.

Although the tool is fairly easy to operate, some basic operating precautions are required. To prevent the blade from grabbing and kicking back, keep a firm grip on the saw handle at all times. In addition, before installing any cutting blade on the tool, the blade should be checked carefully for cracks. A crack could cause the blade to fail during operation, thereby causing parts to fly out, possibly causing serious injury to the operator or bystanders. [Figure 2-26]

Reciprocating Saws

A reciprocating saw is an electrically powered tool used for rough cutting of large damaged sections such as portions of spars or stringers. With these saws, a variety of cutting blades is available to be used on different types and thickness of materials. The cutting blades used to cut through metal are

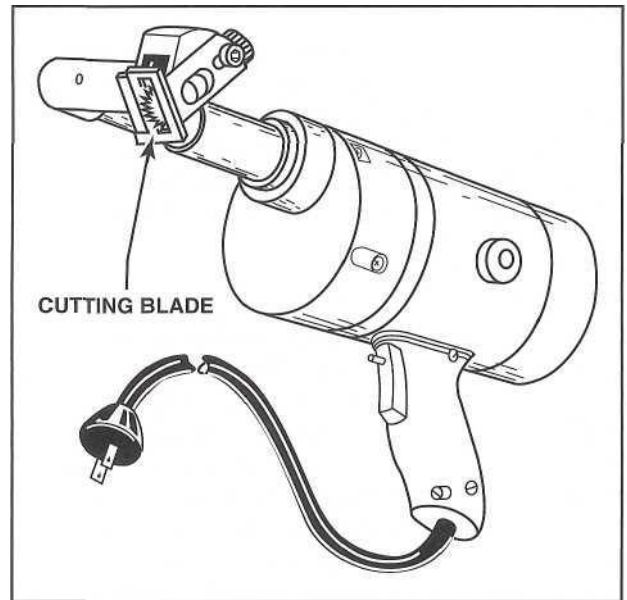

Figure 2-26. A Ketts saw uses various circular metal-cutting blades to easily remove damaged sections of sheet metal.

primarily made of good quality steel and are available with different numbers of teeth per inch of blade. For metal .250 inch or thicker, use a coarse cutting blade. However, if a coarse blade is used on thin metal, the blade can hang up, dull rapidly, or break. [Figure 2-27]

The **saber saw** is another tool that is commonly used for sheet metal repair work. These tools are electrically powered and similar in operation to the reciprocating saw. Often, the saber saw is used to cut holes in flat sheets of metal such as on wings or control surfaces, or for rough cutting the edges of sheet metal parts. One advantage of using the saber saw is that its shoe plate can be tilted, allowing for bevel-edged cuts. Like the reciprocating saw, saber saws can be adapted to cut materials other than metal by using different styles of cutting blades.

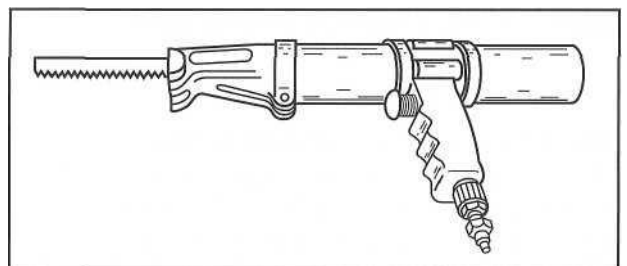

Figure 2-27. When using a reciprocating saw for metal cutting, make certain to use a blade with the proper number of teeth for the particular operation. In all cases, the manufacturer's information regarding the correct blades to use, and proper tool operation, should be consulted and followed.

Nibblers

A nibbler is a tool used for rough cutting small- to medium-size holes in skins, radio chassis, and instrument panels. These tools may be electrically or pneumatically powered, but are also available in a non-powered hand version. Regardless of the operating power, each tool produces a similar style cut.

The main advantage of a nibbler, aside from its simplicity of operation, is the ability to use the tool for making detailed inside cuts. To make a cut, the edge of the sheet metal is placed in a slot in the face of the tool. By pulling a trigger, a cutting blade moves down to shear out a small rectangular section of metal about 1/8 inch deep by 3/16 inch wide. As the metal is fed into the tool, the action repeats until the opening is made to the desired size. One disadvantage of the nibbler however, is that it tends to leave a rough edge requiring the use of a file to smooth the metal once the cut is complete. For this reason, the initial cut should be made leaving excess material, permitting filing to be used to achieve the exact finished dimension. [Figure 2-28]

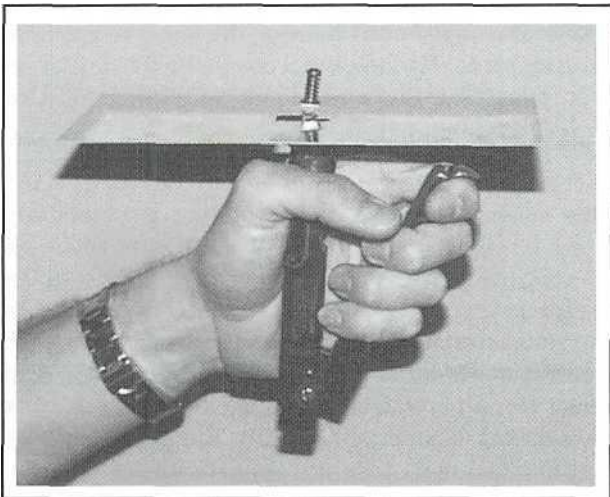

Figure 2-28. Manual and powered nibblers are used to cut out rough-open cutouts in sheet metal. To make inside cuts, it is necessary to drill a pilot hole in the metal large enough to allow the nose of the tool to pass through the hole.

NON-POWERED HAND CUTTING TOOLS

Non-powered hand cutting tools are useful since no outside power is required for their operation, making them ideal for field repairs. These tools also offer control over the amount of cut, which is often lacking when using power tools. Since there are so many types of non-powered cutting tools available, only a few of the most common types will be discussed in this section.

Sheet Metal Shears

One of the most common hand cutting tools used by sheet metal technicians is a pair of tin snip cutters. These cutters are considered useful for cutting metal to a rough shape, but for more accurate and detailed cuts, aviation snips are used. [Figure 2-29]



Figure 2-29. Hand shears and aviation snips are used for cutting thin sheet metal.

Aviation Snips

Aviation snips are compound action shears which have a serrated cutting edge that holds the metal that is being cut. Aviation snips come in sets of three and are manufactured to perform different cuts as indicated by a color-code on the handles. Snips with yellow handles cut straight, those with green handles cut to the right, and snips with red handles cut to the left.

Files

When aircraft sheet metal skins or other parts with close tolerances need to fit together, a file is often used to provide a finished edge or surface. A detailed description of the file is given in Chapter 9, *Hand Tools and Measuring Devices* of the *ASrP Technician General Textbook*, but is briefly discussed here as a review of basic file use and care as it pertains to sheet metal work.

Due to the tolerances and detailed shapes sometimes required when fabricating sheet metal parts, a wide variety of files may be required to complete a sheet metal repair or alteration. For most sheet metal work, the common files include the standard rectangular, half round, three-square, round or rat-tail, and knife-edge shapes. With most of these shapes, the file is available in either a single- or double-cut variety.

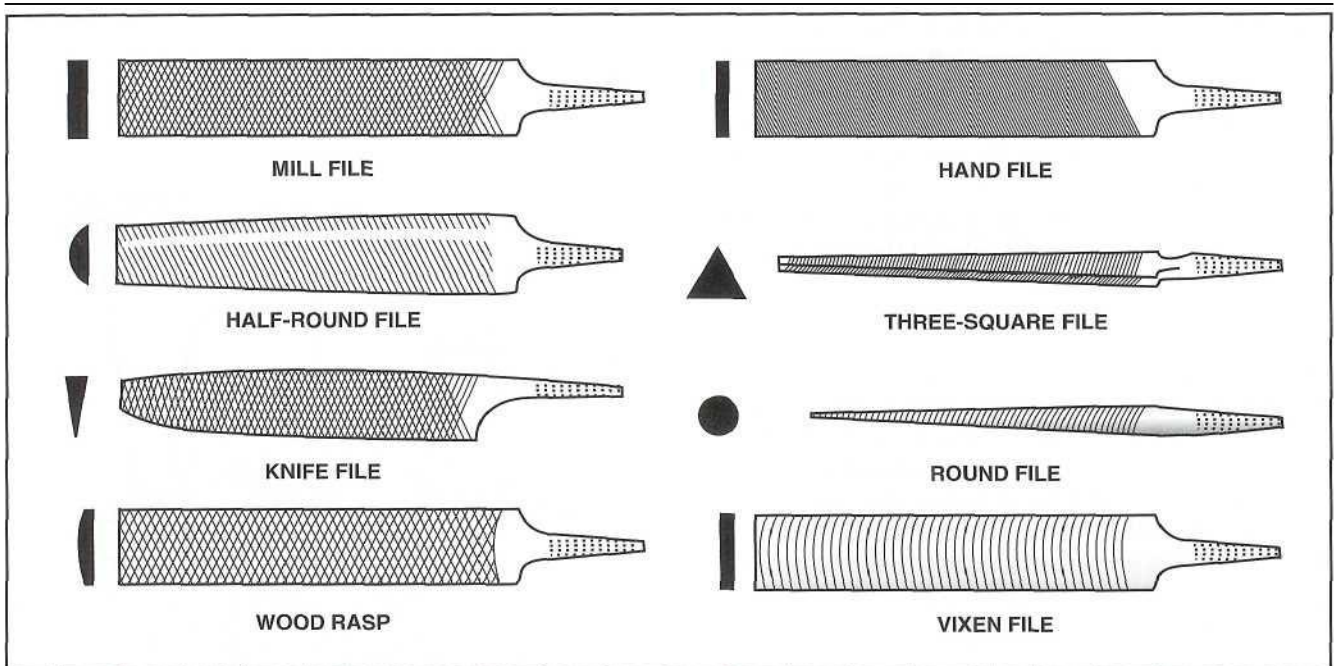

Figure 2-30. Files are available in all sorts of shapes, sizes, and styles. The most common file shapes are shown here.

Keep in mind that single-cut files are primarily used to provide a smooth finish by removing a small amount of material with each draw, while double-cut files provide faster cutting action but leave a rougher finish. Each of these files is also usually available in a variety of coarseness of cuts including coarse cut, bastard cut, second cut, smooth cut and dead smooth cut. As with any hand tool, it is important to select the tool that is designed for the specific task. [Figure 2-30]

File use is also an important consideration. Improper use not only can cause damage to the aircraft part or the file, but also can cause excessive time to be spent on accomplishing a fabrication. To obtain the best results, observe the basic rules of proper file use.

First, remember that a file is a cutting tool with sharp edges in one direction. Generally, when filing metal, do not drag the file backward across the metal with any downward force. Drawing the file backward while pushing down can dull the teeth. However, to help remove soft metal from the teeth, it is acceptable to draw the file backward without any significant downward force to dislodge metal particles. Secondly, before and after using a file, make certain that no metal fragments remain in the teeth by using a file card to brush the teeth out before and after use. It is also advisable to coat a file with light oil before storing the tool for long periods.

Deburring Tools

Once a hole is drilled in sheet metal, it is not uncommon to find that a sharp edge or burrs, is left around the circumference of the hole. A drill several sizes larger than the drilled hole, or a standard countersink cutter held in a file handle, makes a good tool for removing the burrs from the edges of holes. However, a common mistake made by inexperienced technicians is to remove too much material. Remember, a deburring tool should be used to remove burrs and to smooth edges. If too much pressure is applied while deburring, it is possible the hole will become undesirably countersunk. [Figure 2-31]

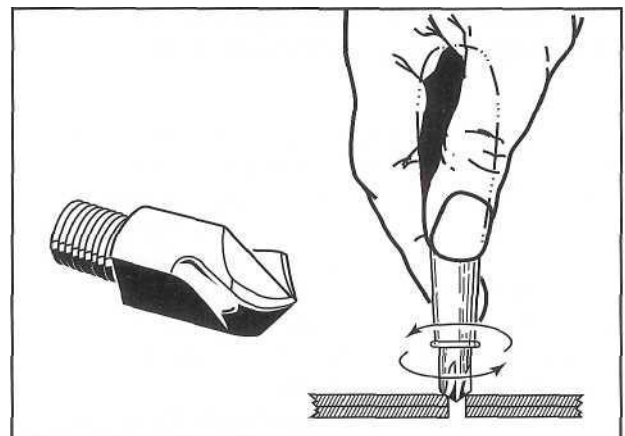

Figure 2-31. When removing the burrs from the edges of a drilled hole, do not cut too deeply. If too much material is removed, the metal will be weakened and any hardware installed in the hole will not have the same shear area to act against.

In addition to sharp edges around holes, when sheet metal is cut, the edge is also left sharp, and with burrs. A file can be used to remove the burrs from the edges of a sheet, but grinding a sharp V-shaped notch in the end of a small file can create a tool that quickens the job. To use the tool, just pull it along the edge of the sheet, and the sharp edges of the "V" will cut the burrs from both sides of the metal at the same time.

SHOPTOOLS

Shop tools, both powered and non-powered, make large-scale and repetitive metal cutting and shaping operations more convenient. Some operations, such as bends in long sheets of metal, can be accomplished only with larger shop equipment. Although most shop tools operate in a similar fashion, consult the tool manufacturer's care and use instructions before using any new equipment.

SQUARING SHEAR

Of all shop tools, a squaring shear is one of the most commonly used tools for sheet metal work. A typical size shear will accept a full 4 foot-wide sheet with the capacity to handle up to a 14-gauge soft metal, but capacity varies widely depending on manufacturer. Most shops use foot-operated shears, but when thick metal must be cut, the shears are operated by electric motors. [Figure 2-32]

Squaring shears have a guide edge that is adjustable to keep the material exactly perpendicular to the blade. Since the guide is adjustable, it is important to periodically check the alignment by making a sample cut, and checking the finished edge with a combination square. This is especially important to check before making cuts in wide sheets.

In addition to the alignment guide, squaring shears also have an adjustable stop fence for setting the depth of a cut, as well as a clamp for holding the metal tight against the table. The clamp allows fingers to be kept away from the blade during operation. When the metal is in place, stepping on a treadle, or foot pedal, causes the clamp to drop down on the metal to hold it firmly as the blade shears across the material. When properly used and maintained, squaring shears will cut metal smoothly, and leave a minimum of burrs on the edges of the material.

However, it should be remembered that a squaring shear can be a dangerous piece of equipment.

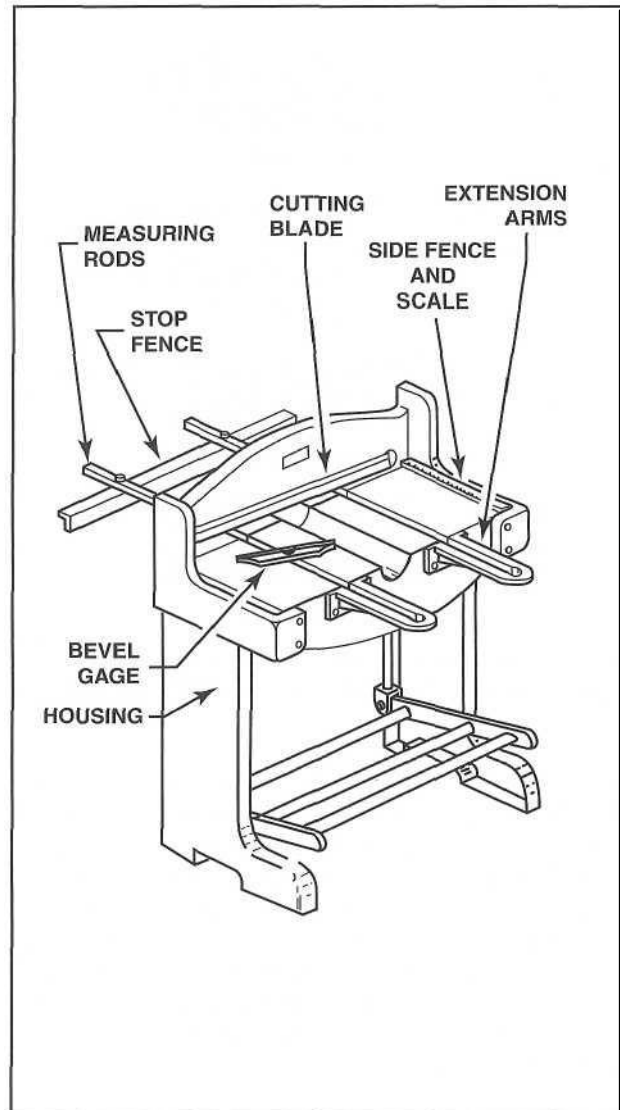

Figure 2-32. A squaring shear is used to make straight cuts across sheet metal.

Exercise care whenever using a squaring shear to verify that all fingers are clear before depressing the treadle. This is especially true when working with another person who may be helping with positioning large metal sheets.

THROATLESS SHEARS

Throatless shears are best used to cut 10-gauge mild carbon sheet metal, or up to 12-gauge stainless steel. The shear gets its name from its construction because it actually has no throat in the frame of the tool. Without this throat, there are no obstructions during cutting, which allows for more mobility in making detailed cuts. In effect, a sheet of any length can be cut, and the metal can be turned in any

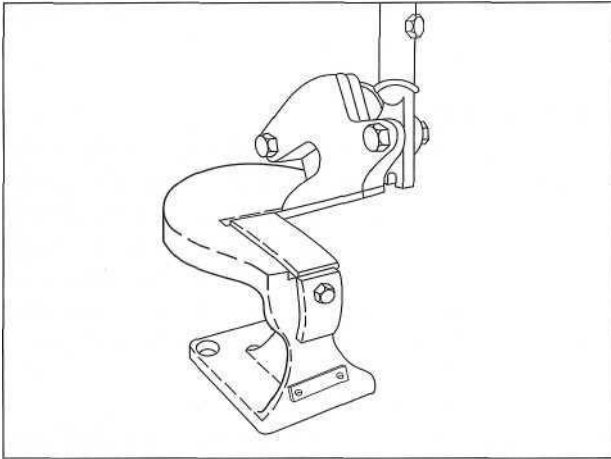

Figure 2-33. The action of throatless shears resembles a large pair of scissors. A hand lever that causes it to shear across a fixed lower blade operates the cutting blade (top blade).

direction to allow for cutting irregular shapes. [Figure 2-33]

ROTARY PUNCH PRESS

A rotary punch press is used in an airframe repair shop to punch holes in metal parts, for cutting radii in corners and for many other jobs where circular cuts are required. The machine is composed of two cylindrical turrets, one mounted over the other and supported by the frame. Both turrets are synchronized so that they rotate together, with index pins ensuring correct alignment at all times. The index pins may be released from their locking position by rotating a lever on the right side of the machine. This action withdraws the index pins from the tapered alignment holes and allows an operator to run the turrets to any size punch desired. [Figure 2-34]

To operate the machine, select the desired punch by looking at the stamped size on the front of the die holder. Then place the metal to be worked between the die and punch by positioning the desired center of the hole over a raised teat on the turret. Pulling the lever on the top side of the machine toward you actuates a pinion shaft, gear segment, toggle link and ram, forcing the punch through the metal. When the lever is returned to its original position, the metal is released from the punch.

BAND SAW

When sheet metal must be cut along curved lines, or when the metal is too thick to shear, a band saw can be used to cut the metal. One of the most versatile band saws found in aircraft sheet metal shops is a "Do-all" saw. This saw has a variable speed drive

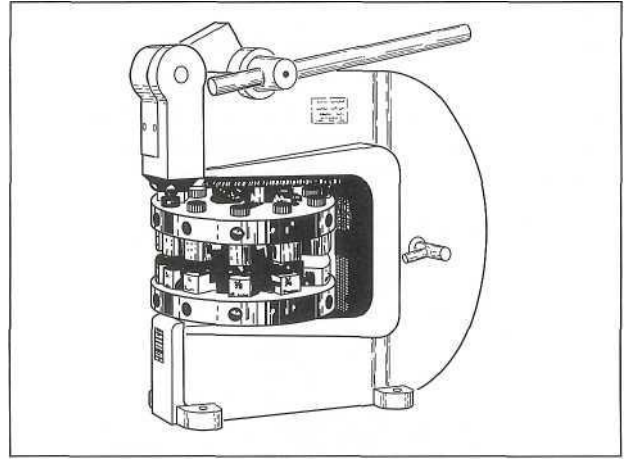

Figure 2-34. The hand-operated rotary punch press is used to punch holes or make radius cuts in metal parts.

that allows the correct cutting speed to be adjusted for any metal. In addition, the table can be tilted so bevels and tapers can be cut on thick metal.

However, one of the most useful features of this saw is a blade cutter and welding machine. If a large opening or inside hole needs to be cut, a starting hole can be drilled, the saw blade cut in two, and then inserted through the hole. Then, with a resistance 'welder that is built into the saw, the blade can be welded back together. With just a few minutes of effort, the saw is ready to cut the inside of the hole. [Figure 2-35]

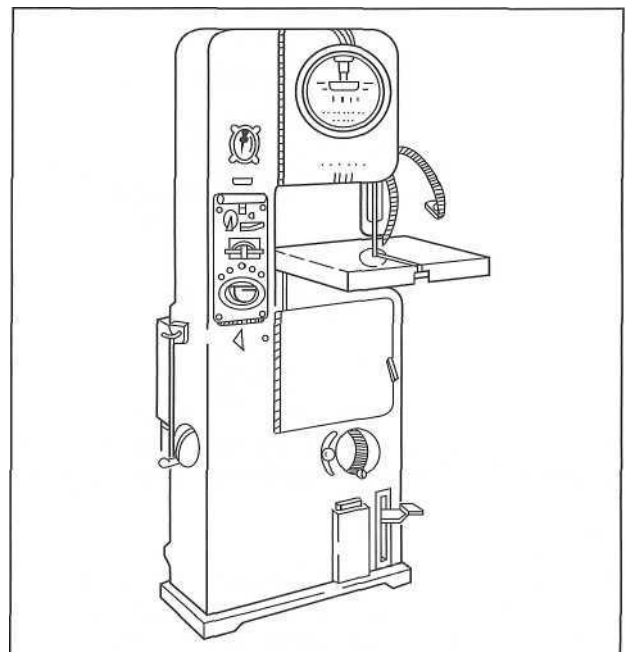

Figure 2-35. A "Do-all" band saw is useful for cutting curved lines in metal, wood, or plastic because the blade speed is adjustable to vary for different types of materials.

DISC SANDER

Wood, plastic materials, and sheet metal can be cut by the band saw to almost the correct size and then finished very accurately with a heavy-duty disc sander. With this tool, the material can be milled right up to a scribed line. [Figure 2-36]

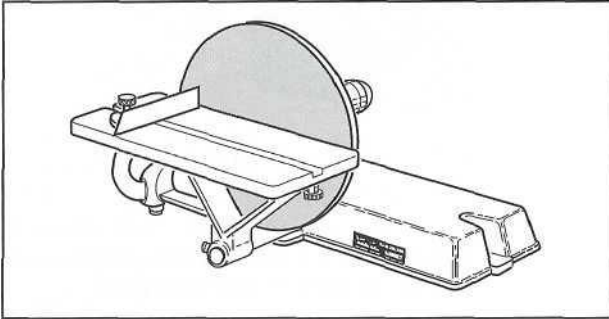

Figure 2-36. A disc sander is used to trim curved cuts in sheet metal, wood, or plastic after they have been rough-cut by a band saw.

SCROLL SHEARS

Scroll shears are used for cutting irregular lines on the inside of a sheet without cutting through from the edge. With this tool, the upper cutting blade is stationary while the lower blade is movable. By moving a handle connected to the lower blade, the shear can pierce the center of a piece of sheet metal, and cut in a similar fashion as a can opener. [Figure 2-37]

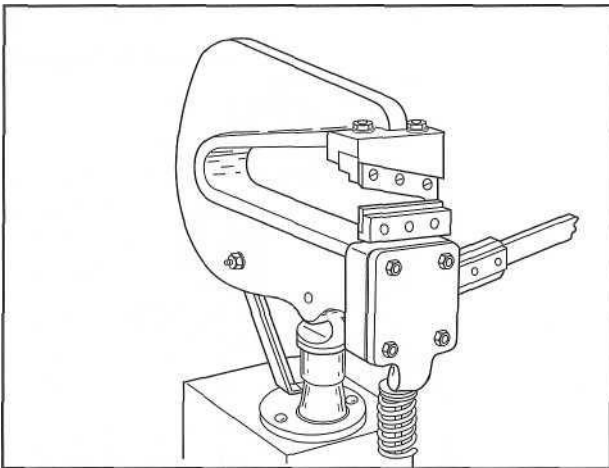

Figure 2-37. Scroll shears are used to make irregular cuts on the inside of a sheet without cutting through to the edge.

DRILLS

Aviation maintenance technicians use drills and associated attachments almost more than any other tool when fabricating sheet metal components. Drills can be either hand-operated or shop mounted. Again, always become familiar with the tool manufacturer's operating and safety instructions, and

with specific operating instructions, before using any equipment for the first time.

DRILL MOTORS

The vast majority of holes drilled in aircraft sheet metal structure is small and drilled in relatively soft metal. For this reason, there is seldom a need for a drill motor larger than one with a 1/4 inch chuck. Recall that the chuck is the part of the motor that holds the cutting drill in place, and comes in a variety of sizes depending on the power of the drill motor.

Electric Drill Motors

The convenience of electric outlets in the shop and the relatively low cost of electric drill motors, as compared with air drills, make them useful tools. In addition, a variable speed control makes these tools even more useful. However, an electric drill motor is larger and heavier than an air drill and has the potential for producing an electric spark or shock when being used on an aircraft structure. For these reasons, air drills, rather than electric drills, are generally more accepted for sheet metal work. [Figure 2-38]

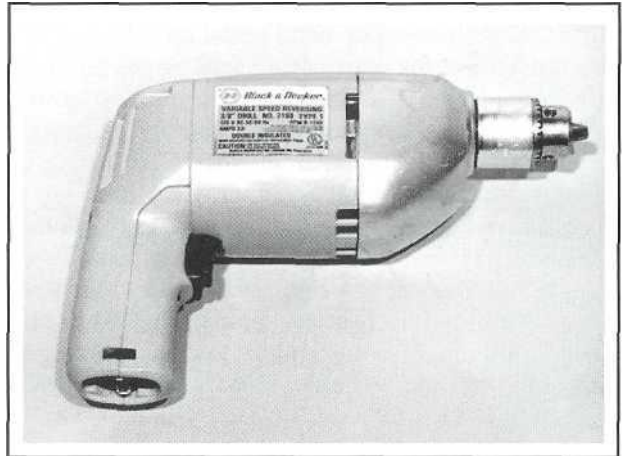

Figure 2-38. An electric drill motor is often used for sheet metal repair work when a supply of compressed air is not readily available. Rechargeable battery-powered drills are also commonly used for small sheet metal repairs because of the convenience of use, but should not be used around compartments containing flammable fluids such as fuel cells.

Pneumatic Drill Motors

The availability of compressed air to operate rivet guns makes pneumatic, or air drill motors, a logical choice for aircraft structural repair. These drills are lightweight, have good speed control, do not overheat regardless of use-frequency, and are available in a number of shapes that allows them to be used in difficult locations. [Figure 2-39]



Figure 2-39. A pneumatic, or air drill motor, is the most widely used drilling tool for aircraft sheet metal repair work.

The most popular air drill motor is the pistol grip model with a 1/4 inch chuck. The speed of these drills is controlled by the amount of pull on the trigger, but if it is necessary to limit the maximum speed, a regulator may be installed at the air hose where it attaches to the drill. The regulator can then be adjusted for the maximum amount of air entering the drill to limit the maximum speed, even with the trigger fully depressed.

For drilling holes where the structure interferes, a right-angle drill attachment is available. In addition, if the chuck and the length of the twist drill prevent getting the drill motor in where it is needed, a right-angle drill motor equipped to use short-threaded twist drills can be used. [Figure 2-40]

DRILL ATTACHMENTS AND SPECIAL DRILLS

Drill jigs are used to assist in drilling accurate holes in skins and structural subassemblies. These are held in place by drilling one hole and anchoring the jig so it can be used as a template to drill numerous additional holes. The alignment of the jig makes it

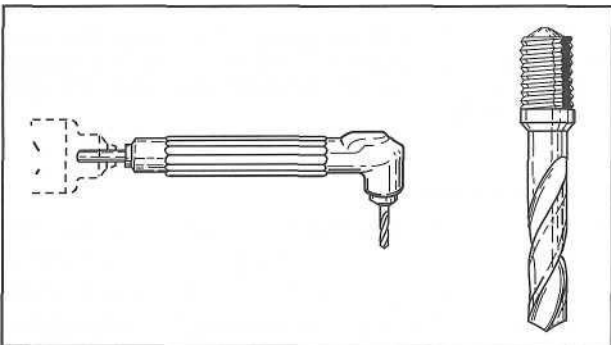

Figure 2-40. Threaded shank twist drills are used in drill motors for a number of reasons. One of the primary reasons is that the twist drill will not slip in the chuck when subjected to an excessive amount of torque.

possible to obtain holes that are round, straight, and free from cracks. This is especially true when the metal is thick where holes drilled freehand have a tendency to be made crooked. Drill jigs are most commonly used during the assembly process while an aircraft is being built. For example, drill jigs are very useful for installing anchor nuts or anything else that requires holes to be made with a high degree of repetitive dimensional accuracy.

A drill attachment used a great deal by sheet metal technicians during the disassembly of a damaged aircraft, is a rivet removal tool. A rivet removal tool is available with interchangeable twist drills that correspond to standard rivet sizes. Drilling out rivets is made easier because the tool can be adjusted to cut only to the depth of the manufactured rivet head. The procedure is then the same as for the freehand rivet removal technique. Once the head is drilled, simply tap or snap off the drilled head, and tap out the rivet shank with a hammer and pin punch. Again, the material should be backed up with a bucking bar or other similar device to prevent damaging the base metal while the shank is driven out.

Right-Angle Drills And Attachments

Angled drill motors are designed for operation in tight locations where there is limited access to the structure being drilled. Angled drill motors are available in two standard head angles of 45 degrees and 90 degrees. However, for access into even tighter locations, angled drill motor attachments are also available. [Figure 2-41]

A right-angled drill motor attachment is primarily used to open holes in close quarters where even an angled drill motor cannot work. The attachment is chucked into a straight pistol-type motor. The twist drill used on a right angle attachment is installed in a collet, which can hold a standard twist drill. When the twist drill becomes too short in the collet,

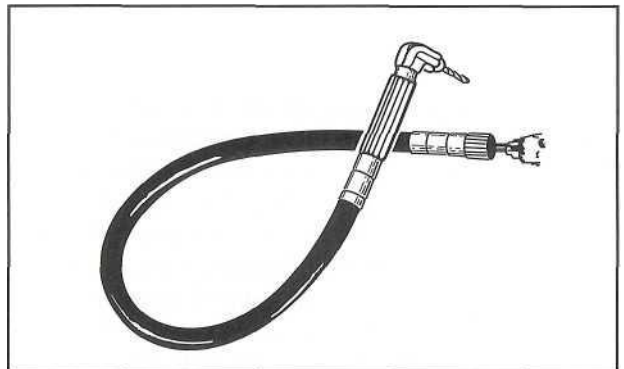

Figure 2-41. The right-angle attachment allows access into locations that are inaccessible with a standard drill motor.

it can be replaced with a broken straight drill with a newly sharpened tip. The twist drill is pressed into the collet and held in place by pressure exerted by the compressed wall of the collet when it is tightened in the attachment's holder.

Snake Attachments

A flexible snake attachment may be used in limited access areas where an angle drill motor or angle attachment cannot be used. The snake attachment basically performs the same function that a right-angle attachment does, except it can be snaked in to drill a hole much farther away than can a right-angle drill. These are excellent tools for getting into locations that a regular motor can't, because the handle will not permit a straight entry on the part being drilled. One use for a snake attachment is for back-drilling through holes in original members, into new, undrilled skins. Back-drilling is done to open holes in new skins through preexisting holes drilled in ribs, stringers, or spars, which were previously made during the original installation of sheet metal parts. [Figure 2-42]

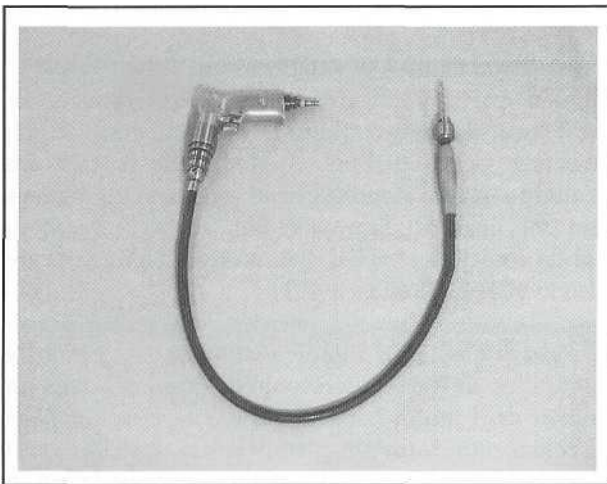

Figure 2-42. A snake attachment with its right angle and threaded twist drill permits access through lightening holes to back-drill skin repairs.

Extension Drills

There are applications in aircraft maintenance where it is necessary to reach through a part of the structure to drill a hole that is beyond the reach of an ordinary twist drill. When this type problem occurs, there are two types of extension drills available to use. One is simply a long drill that must have a piece of aluminum tubing slipped over the shank to prevent it from whipping during use. The other has a heavy shank with a small drill fixed into its end and needs no protective cover, as it is too rigid to whip. [Figure 2-43]

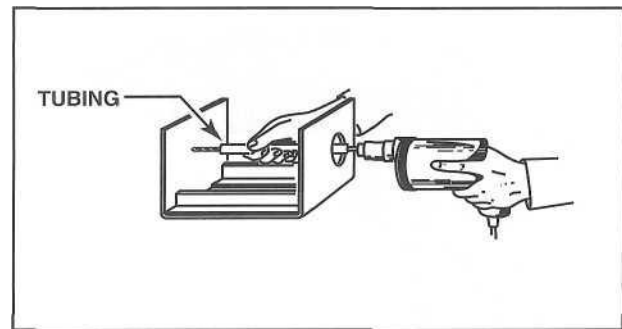

Figure 2-43. With thin shank extension drills, when pressure is applied during the drilling operation, the twist drill can bend and cause whipping. To prevent whipping, the twist drill is placed in a hollow tube to provide support for the drill.

SPRING DRILL STOPS

Although it is not uncommon to need a drill that is reasonably long, it is also important to be conscientious of the fact that a twist drill may be too long for a given application. In fact, it is often necessary to limit the amount that a twist drill can penetrate through a part to prevent damaging components on the other side of the drilled structure. A device that is often used to limit twist drill penetration is a spring drill stop. These stops come in assorted sizes and use a set screw to anchor the stop to the twist drill at any desired position. In this fashion, the exposed length of the twist drill end can be adequately controlled to prevent the drill from penetrating too far through the structure. [Figure 2-44]

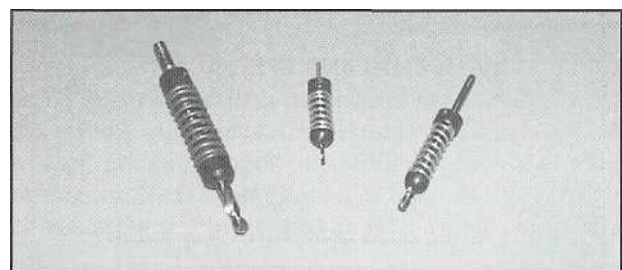

Figure 2-44. Drill stops are typically color coded to match the drill size. Silver stops are used with No. 40 drills; copper stops are used with No. 30 drills; and black stops are used with No. 21 drills.

DRILL PRESSES

Drill presses are available in a variety of styles with the most common being the upright variety. When the upright drill press is in use, the height of the drill table is adjusted to accommodate the height of the part to be drilled. When the height of the part is greater than the distance between the drill and the table, the table is lowered. When the height of the part is less than the distance between the table and

the drill chuck, when it is at its full extension, the table is raised to permit the drill to penetrate completely through the part.

Once the table is properly adjusted, the part is placed on the table, and the drill is brought down to aid in positioning the part so that the hole to be drilled is directly beneath the drill point. The part is then clamped to the table to prevent it from slipping during the drilling operation. Parts not properly clamped may bind on the drill and start spinning, causing the operator to suffer serious cuts or the loss of fingers. To prevent injuries, always make sure the part is properly clamped before starting the drilling operation. Never attempt to hold a part by hand.

Another consideration when using a drill press is to make certain to never leave a chuck key in the drill chuck. Failure to remove the key before turning the drill press on will cause the key to fly out, possibly causing serious injury to the operator or bystanders. [Figure 2-45].

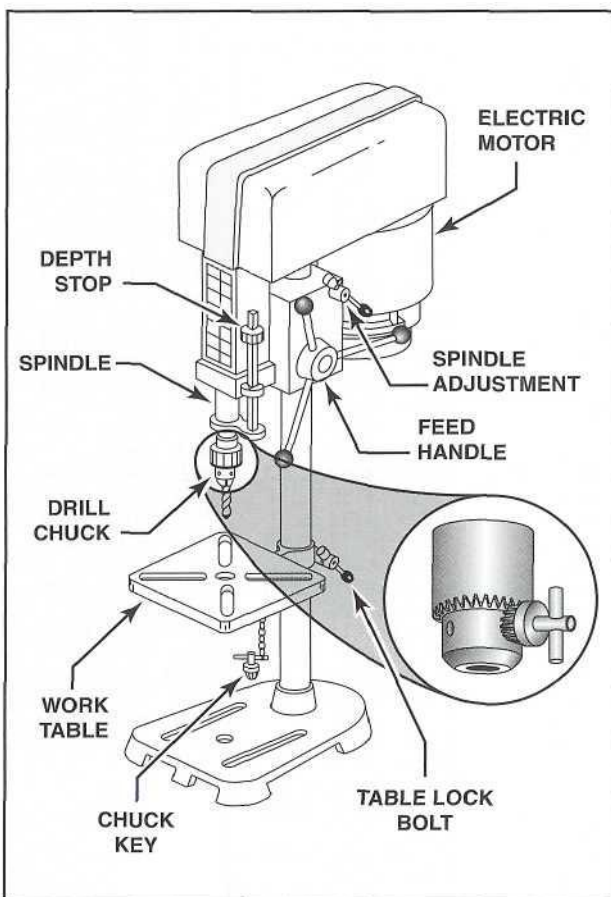

Figure 2-45. To increase the accuracy and straightness of a drill press when using a twist drill, it is recommended to tighten the chuck by using each of the key holes in unison around the chuck. This tends to provide an even tension on the shank of the twist drill and helps to ensure straightness.

TWIST DRILLS

Twist drills are used for opening holes in metal, wood, and other materials. A twist drill has three main parts consisting of the tip, body, and shank. The tip includes two cutting lips that are normally sharpened to a 59 degree angle from the center-line. This produces an included angle of 118 degrees while the heel of the tip is normally ground to an angle of about 12 to 15 degrees. However, depending on the type material being cut, twist drills can have different angles to provide optimum performance.

The shank of a drill is the portion that is chucked into the drill motor, whereas the body of the drill includes hollow flutes and reamer lands. The flutes aid in carrying material out of the hole while also providing a method for cooling-oil to be delivered to the cutting surface. The reamer lands, which are also part of the body, serve to provide a finished dimension to the hole. [Figure 2-46]

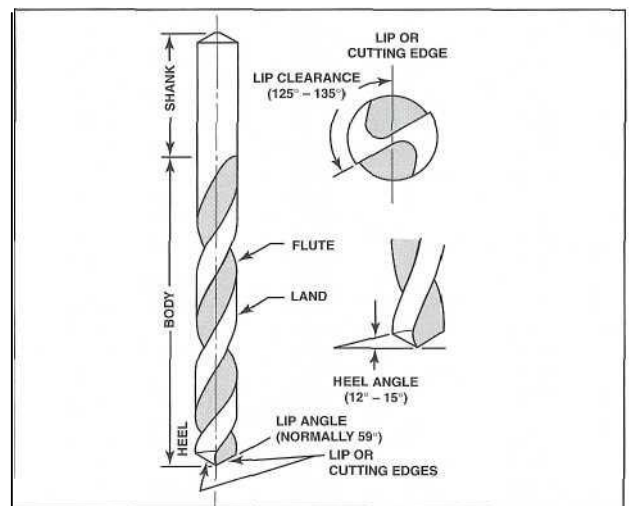

Figure 2-46. On a typical metal drill, the cutting edges on the point perform the actual cutting. The lands and flutes remove the cut material and carry lubricant to the cutting edges as well as provide a finished cut for proper dimensions.

Some materials require different included and heel angles to be ground on the tip, while motor speeds and pressures may also need to be varied. To cut holes in aircraft aluminum, an included angle of 118 degrees should be used with a high tip speed and steady pressure on the drill. For soft materials such as plastics, an included angle of 90 degrees should be used with drill motor speeds and pressures being adjusted for the particular density. Stainless steels, on the other hand, require an included angle of 140 degrees with a slow tip speed and reasonably heavy drill motor pressure.

Drill diameters are distinguished in one of four ways by either a number, fraction, letter, or decimal. For sheet metal work, number and letter drills are the types most widely used. Numbered and letter drills are identified in place of fractional drills in order to provide a clearance to accept fractional sized rivets and other hardware. For example, a No. 30 drill has a diameter of .1285 inches whereas a -4

rivet has a diameter of 1/8 or .125 inches. Since the No. 30 drill is .0035 inches larger, the rivet will easily fit into the hole without an excessive clearance. Although fractional drills come in 1/64 inch increments in sizes less than one inch in diameter, if a fractional drill is used, the clearances will either be too close, or too extreme to permit proper hardware clearance. [Figure 2-47]

Milli-meter	Dec. Equiv.	Frac. tional	Num-ber	Milli-meter	Dec. Equiv.	Frac. tional	Num-ber	Milli-meter	Dec. Equiv.	Frac. tional	Num-ber	Milli-meter	Dec. Equiv.	Frac. tional	Num-ber	Milli-meter	Dec. Equiv.	Frac. tional	Num-ber	Milli-meter	Dec. Equiv.	Frac. tional	Num-ber
.1	.0039	1.45	.0570	3.2	.1260	5.4	.21263230	P	14.5	.5709
.15	.0059	1.5	.0591	3.25	.12792130	3	8.25	.3248	14.68	.5781	37/64
.2	.00790595	531285	30	5.5	.2165	8.3	.3268	15.0	.5906
.25	.0098	1.55	.0610	3.3	.1299	5.56	.2187	1/32	8.33	.3281	21/64	15.08	.5937	19/32
.3	.0118	1.59	.0625	1/16	3.4	.1338	5.6	.2205	8.4	.3307	15.48	.6094	39/64
....	.0135	80	1.6	.06291360	292210	23320	Q	15.5	.6102
.35	.01380635	52	3.5	.1378	5.7	.2244	8.5	.3346	15.88	.6250	5/8
....	.0145	79	1.65	.06491405	28	5.75	.2263	8.6	.3386	16.0	.6299
.39	.0156	1/64	1.7	.0669	3.57	.1406	9/642280	13390	R	16.27	.6406	41/64
.4	.01570670	51	3.6	.1417	5.8	.2283	8.7	.3425	16.5	.6496
....	.0160	78	1.75	.06891440	27	5.9	.2323	8.73	.3437	11/32	16.67	.6562	21/32
.45	.01770700	50	3.7	.14572340	A	8.75	.3445	17.0	.6693
....	.0180	77	1.8	.07091470	26	5.95	.2344	15/64	8.8	.3465	17.06	.6719	43/64
.5	.0197	1.85	.0728	3.75	.1476	6.0	.23623480	S	17.46	.6875	11/16
....	.0200	760730	491495	252380	B	8.9	.3504	17.5	.6890
....	.0210	75	1.9	.0748	3.8	.1496	6.1	.2401	9.0	.3543	17.86	.7031	45/64
.55	.02170760	481520	242420	C3580	T	18.0	.7087
....	.0225	74	1.95	.0767	3.9	.1535	6.2	.2441	9.1	.3583	18.26	.7187	23/32
.6	.0236	1.98	.0781	5/641540	23	6.25	.2460	D	9.13	.3594	23/64	18.5	.7283
....	.0240	730785	47	3.97	.1562	5/32	6.3	.2480	9.2	.3622	18.65	.7344	47/64
....	.0250	72	2.0	.07871570	22	6.35	.2500	1/4	E	9.25	.3641	19.0	.7480
.65	.0256	2.05	.0807	4.0	.1575	6.4	.2520	9.3	.3661	19.05	.7500	3/4
....	.0260	710810	461590	21	6.5	.25593680	U	19.45	.7656	49/64
.7	.02760820	451610	202570	F	9.4	.3701	19.5	.7677
....	.0280	70	2.1	.0827	4.1	.1614	6.6	.2598	9.5	.3740	19.84	.7812	25/32
....	.0292	69	2.15	.0846	4.2	.16542610	G	9.53	.3750	3/8	20.0	.7874
.75	.02950860	441660	19	6.7	.26383770	V	20.24	.7969	51/64
....	.0310	68	2.2	.0866	4.25	.1673	6.75	.2657	17/64	9.6	.3780	20.5	.8071
.79	.0312	1/32	2.25	.0885	4.3	.1693	6.75	.2657	9.7	.3819	20.64	.8125	13/16
.8	.03150890	431695	182660	H	9.75	.3838	21.0	.8268
....	.0320	67	2.3	.0905	4.37	.1719	11/64	6.8	.2677	9.8	.3858	21.03	.8281	53/64
....	.0330	66	2.35	.09251730	17	6.9	.27163860	W	21.43	.8437	27/32
.85	.03350935	42	4.4	.17322720	I	9.9	.3898	21.5	.8465
....	.0350	65	2.38	.0937	3/321770	16	7.0	.2756	9.92	.3906	25/64	21.83	.8594	55/64
.9	.0354	2.4	.0945	4.5	.17712770	J	10.0	.3937	22.0	.8661
....	.0360	640960	411800	15	7.1	.27953970	X	22.23	.8750	7/8
....	.0370	63	2.45	.0964	4.6	.18112811	K4040	Y	22.5	.8858
.95	.03740980	401820	14	7.14	.2812	9/32	10.32	.4062	13/32	22.62	.8906	57/64
....	.0380	62	2.5	.0984	4.7	.1850	13	7.2	.28354130	Z	23.0	.9055
....	.0390	610995	39	4.75	.1870	7.25	.2854	10.5	.4134	23.02	.9062	29/32
1.0	.03941015	38	4.76	.1875	3/16	7.3	.2874	10.72	.4219	27/64	23.42	.9219	59/64
....	.0400	60	2.6	.1024	4.8	.1890	122900	L	11.0	.4330	23.5	.9252
....	.0410	591040	371910	11	7.4	.2913	11.11	.4375	7/16	23.81	.9375	15/16
1.05	.0413	2.7	.1063	4.9	.19292950	M	11.5	.4528	24.0	.9449
....	.0420	581065	361935	10	7.5	.2953	11.51	.4531	29/64	24.21	.9531	61/64
....	.0430	57	2.75	.10821960	9	7.54	.2968	19/64	11.91	.4687	15/32	24.5	.9646
1.1	.0433	2.78	.1094	7/64	5.0	.1968	7.6	.2992	12.0	.4724	24.61	.9687	31/32
1.15	.04521100	351990	83020	N	12.30	.4843	31/64	25.0	.9843
....	.0465	56	2.8	.1102	5.1	.20083031	12.5	.4921	25.03	.9844	63/64
1.19	.0469	3/641110	342010	7	7.75	.3051	12.7	.5000	1/2	25.4	1.0000	1
1.2	.04721130	33	5.16	.2031	13/64	7.8	.3071	13.0	.5118
1.25	.0492	2.9	.11412040	6	7.9	.3110	13.10	.5156	33/64
1.3	.05121160	32	5.2	.2047	7.94	.3125	5/16	13.49	.5312	17/32
....	.0520	55	3.0	.11812055	5	8.0	.3150	13.5	.5315
1.35	.05311200	31	5.25	.20673160	O	13.89	.5469	35/64
....	.0550	54	3.1	.1220	5.3	.2086	8.1	.3189	14.0	.5512
1.4	.0551	3.18	.1250	1/82090	4	8.2	.3228	14.29	.5625	9/16

Figure 2-47. Fractional twist drills come in 1/64 inch increments in sizes less than 1 inch and can be compared with equivalent decimal and metric measurements by the use of this chart. In addition, the actual decimal equivalent sizes of numbered and lettered drills can be determined from the chart. This can be useful when selecting drills for the installation of rivets where it is common to use a numbered drill that is approximately .003 inch larger than the shank diameter of the rivet.

FORMING TOOLS

Very few sheet metal skins are perfectly flat. In fact, nearly all require bends or curves that must be shaped in some manner. Forming tools include tools that create straight bends as well as those that create compound curves. Some of these tools are manually powered while others are electrically, pneumatically or hydraulically powered.

PRESS BRAKES

The secret of economical mass production of airplanes lies in the ability of the designer's skill in specifying fabrication methods that require only skilled workers to set up machines, and then having workers of far less skill produce the parts. The press brake needs only die installation and adjustment, and the stops properly set by a skilled worker; then any number of pieces can be formed with relatively unskilled labor. [Figure 2-48]

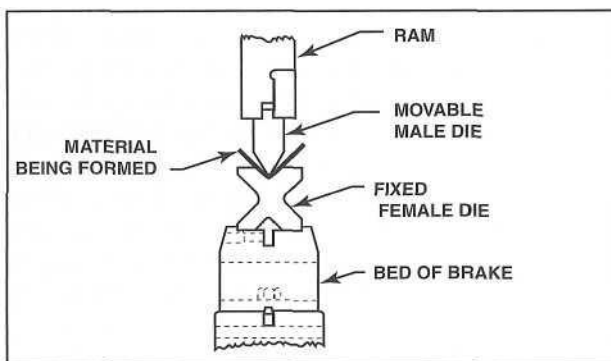

Figure 2-48. The press brake is used for production work where many similar bends must be made in sheet metal.

With press brakes, a female die is fixed and a male die is driven by energy stored in a heavy flywheel by an electric motor. The material is moved over the female die until it rests against the stop and the male die is lowered into it. As the dies come together, they form an accurate bend that can be duplicated many times.

The number and types of dies available for press brakes allow them to be used to make almost any kind of bend in sheet metal. For example, dies are available that bead the edges so wire can be installed to make hinges, or they can also be used to form lock-seams in thin sheet steel, or to form channels and boxes.

CORNICE BRAKES

The cornice brake is one type of widely used bending brake found in most maintenance shops because it will accommodate a wide range of metal thickness. These brakes normally have a rather sharp

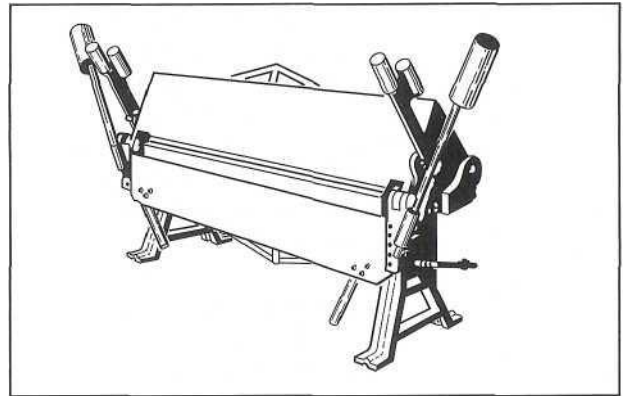

Figure 2-49. The cornice brake, or leaf brake, as it is sometimes called, is one of the most commonly used bend fabricating tools found in many aircraft maintenance shops.

nose bar, around which bars of any desired milled radius may be placed. The bend radius blocks may be moved back away from the edge of the bending leaf to accurately adjust the setback or the distance of the radius from the bending leaf. This is necessary to take into account the thickness of the metal so the metal will hold a tight contour around the radius blocks. [Figure 2-49]

When the correct radius block is in place, the metal to be bent is slipped in the brake and positioned so the bend line is exactly below the beginning of the radius in the radius block. However, since the bend begins under the radius block, it is not possible to see where the bend line begins. To facilitate placing the metal in the correct position, a sight line is marked forward from the bend line approximately at the same distance as the size of the radius. [Figure 2-50]

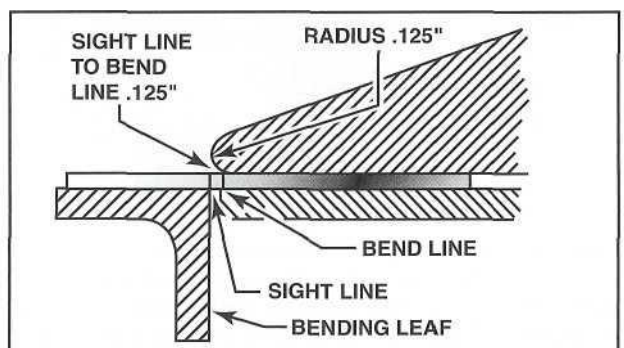

Figure 2-50. By marking a sight line forward of the desired bend line, a technician will be able to align the metal in the nose of the brake so that the bend begins at the correct location. For example, when bending a piece of metal using a 1/8 inch radius in the brake, mark the sight line 1/8 or .125 inches ahead of the desired bend line. Then, when positioning the metal in the brake, look straight down on the nose of the radius block to place the sight line at the front of the bar. A more thorough discussion regarding the setup of bending brakes is covered in the sheet metal bending section later in this chapter.

Once the metal is positioned properly in the brake, a handle is pulled to lower the nosepiece onto the metal. This action holds the metal securely in place while being bent. Bending is accomplished by lifting up on a counterweighted bending leaf, which causes a plate to pivot to force the metal to bend. Raising the leaf higher causes the angle of the bend to increase. When making bends to a specified number of degrees, it is generally necessary to bend past the desired angle. This is because the metal tends to spring back toward a smaller bend angle once the bending leaf is returned to the idle position. Experience facilitates familiarity with how much additional bending is necessary to achieve a finished angle with various metals.

The manufacturer determines the bending capacity of a cornice brake. Standard capacities of this machine are from 12- to 22-gauge sheet metal, and lengths are from 3 to 12 feet. The maximum bending angle of the brake is determined by the bending edge thickness of the radius bars. To provide an increased bending angle, most radius bars are tapered toward their front edge to allow the metal to be bent a maximum amount over the bar. [Figure 2-51]

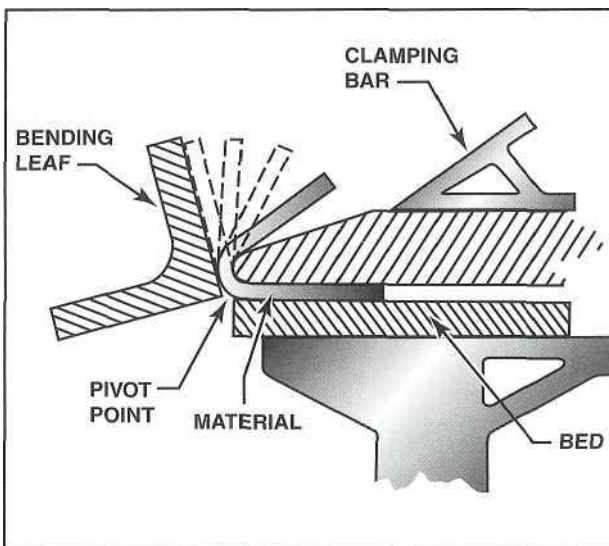

Figure 2-51. To increase the degree of bend that can be achieved with a cornice brake, the radius bars are tapered to allow the bending leaf to have a greater amount of travel.

BAR FOLDING MACHINE

The bar folder is designed for use in making bends or folds along edges of sheets. This machine is best suited for folding small hems, flanges, seams, and edges to be wired. Most bar folders have a capacity for metal up to 22-gauge in thickness and 42 inches in length. [Figure 2-52]

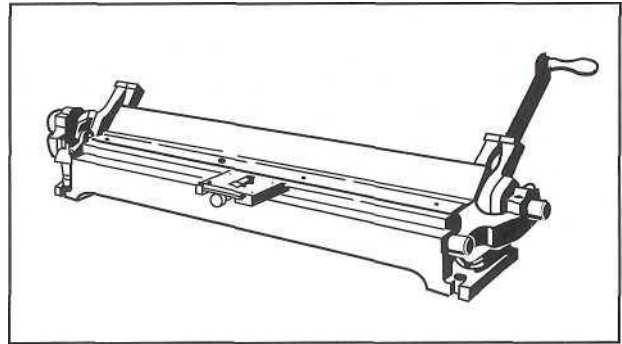

Figure 2-52. The bar folding machine is used to bend the edges of relatively light stock.

Before using the bar folder, several adjustments must be made for thickness of material, as well as the width, sharpness, and angle of fold. Adjusting the screws at each end of the folder makes the adjustment for thickness of material. As this modification is made, place a piece of metal of the desired thickness in the folder and raise the operating handle until a small roller rests on a cam follower. Hold the folding blade in this position and adjust the setscrews so that the metal is clamped securely and evenly through the full length of the folding blade. After the folder has been adjusted, test for uniformity by actually folding small pieces of metal at each end of the machine and comparing the folds.

To make the fold once the machine is adjusted, insert the metal between the folding blade and jaw. Hold the metal firmly against the gauge and pull the operating handle toward you. As the handle is brought forward, the jaw automatically raises and holds the metal until the desired fold is made. When the handle is moved back to its original position, the jaw and blade will return to their original positions and release the metal.

BOX BRAKE

The box brake, sometimes referred to as a pan or finger brake, is probably one of the most widely used forming tools. This extremely handy brake is very similar to the cornice brake except that its top leaf is fitted with a number of radius bars, or fingers. These bars of varying widths can be selected to the dimensions of a box interior in which four sides are bent. Two opposite sides of a box may be formed on a leaf brake, but the last two sides must be formed with a box brake. The fingers are selected to fit just between the two sides that have been formed, and when the box is clamped in place and the leaf is raised, the sides of the box will slip between the

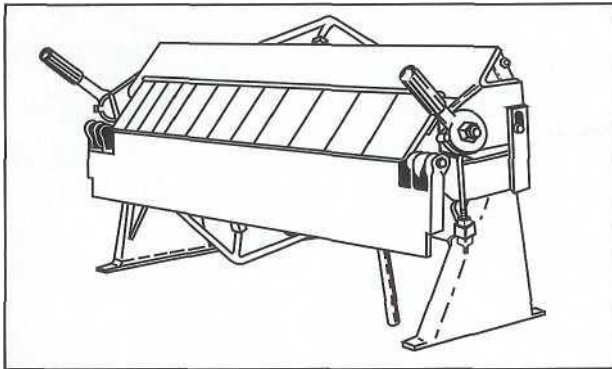

Figure 2-53. The box, or finger brake, is similar to a cornice brake, except that it has split leaves to allow bending of the multiple sides of four-sided box objects.

fingers. This allows the last two sides of the box to be formed. [Figure 2-53]

SLIP ROLL FORMER

All of the machines discussed to this point are used to make rather sharp bends in sheet metal, but sometimes a gentle curve in a part is needed to form a metal tube, or to form a skin for a fuselage. To make these curves, a slip roll former can be used.

A slip roll former is a simple machine consisting of three hard steel rollers in a framework. A drive roller is turned with a hand crank, while a clamp roller is adjustable up or down to provide a tight clamping action to aid in pulling the metal through the machine. In addition to the drive and clamp rollers, a radius roller can be adjusted in or out to increase or decrease the radius being formed in the metal as it passes through the rollers. [Figure 2-54]

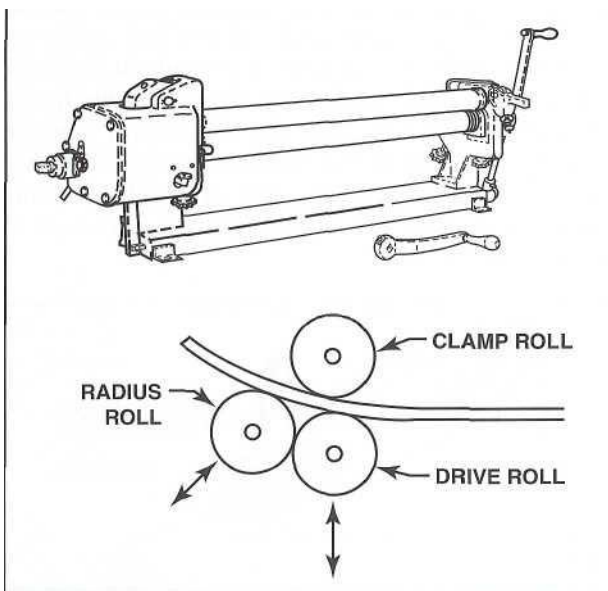

Figure 2-54. A slip roll former is used to make gentle bends to fabricate parts such as tubing or contoured fuselage skins

To use the slip roll former, the metal is placed between the drive and clamp rollers, and the hand crank is turned to pull the metal through the machine. As the metal passes through, it moves over the radius roller. On the first pass, the radius roller should be adjusted to just touch the metal to form a very slight curve. By subsequently passing the metal through the machine with the radius roller adjusted to a tighter fit, the metal will take on a greater curved surface. Each time the metal is rolled through the machine, the radius roller is moved up a bit so it will decrease the radius of the curve in the metal. The metal is passed through the former several times with the radius roller being progressively adjusted to obtain the desired radius.

COMPOUND CURVE TOOLS

In the modern aircraft factory, large compound curved skins are produced on stretch presses where the sheet of metal is grasped in two large sets of jaws, and the sheet is pulled across a male die until it stretches to the desired shape. Once formed, the metal is then trimmed to the proper size.

Stretch Press

Stretch presses are usually found in an aircraft factory. However, variations of this tool can be rented for use in small repair shops or by aircraft home-builders. These tools are used to form compound curved parts by pulling the sheet across a male die. When formed in this manner, the metal obtains a certain amount of strength and rigidity by being left in a cold-worked condition.

Drop Hammer

A process that has been used longer than the stretch press is drop hammer forming. In this process, large matching metal male and female dies are used. By placing sheet metal over the female die and dropping or slamming the male die onto the female die, the metal will be forged into the contoured shape. This method of forming tends to make a uniform grain pattern in the metal, causing the strength of the material to increase.

Hydropress

Smaller components such as fuselage formers, wing ribs, and all types of compound curved brackets are formed in a hydropress. With a hydropress, a blank for the part is punched out of sheet metal on a punch press. The blank is then placed over a metal male die and held in place with tooling pins sticking through holes in the blank. The die is placed on the bed of a hydropress; then a ram, which carries a thick rubber blanket, is lowered over the die. A

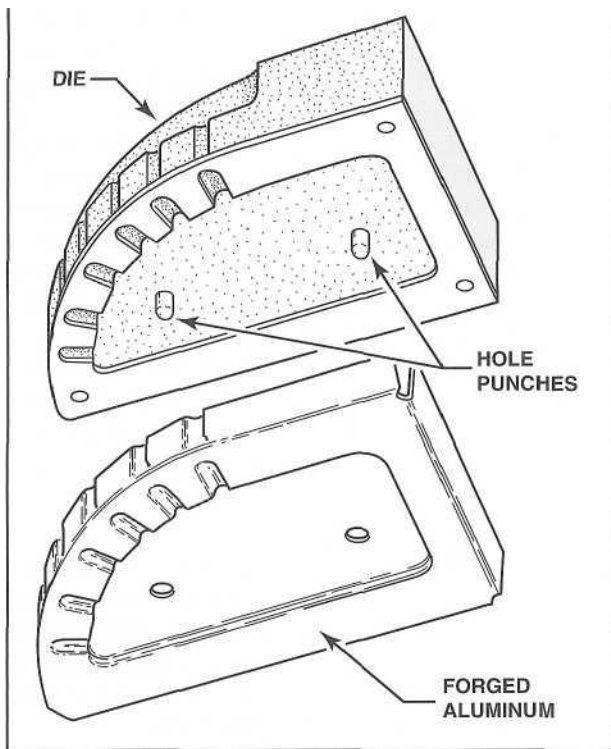

Figure 2-55. A hydropress uses water pressure to force a piece of sheet metal to assume the shape of the die.

pressure of several thousand tons is applied to press the rubber down over the metal, making it conform to the shape of the die. [Figure 2-55]

Shrinkers And Stretchers

Shrinking and stretching tools are used to form contours in parts by expanding or compressing metal to make it form a curved surface. For example, when the edge of sheet metal is worked in a stretcher, the edge will expand, causing it to form an outside curve. Conversely, a shrinker causes the metal to contract, which causes the metal to form an inside curve. Each tool is constructed in a similar fashion in that they both consist of two pairs of heavy jaws that are operated by a hand lever or foot pedal. In each tool, gripping jaws are opened and the edge of the material is placed between them.

With a shrinker, pulling down on a lever or hydraulically operating the tool by a foot pedal causes the jaws to grip the metal and then move inward to compress a small portion of the edge. With a stretcher, the opposite is true in that the jaws grip the metal and then spread apart. By progressively working the metal over a certain distance along its edge, the metal will eventually begin to take on a contoured radius. The jaws do not move enough to buckle or tear the metal, but just enough

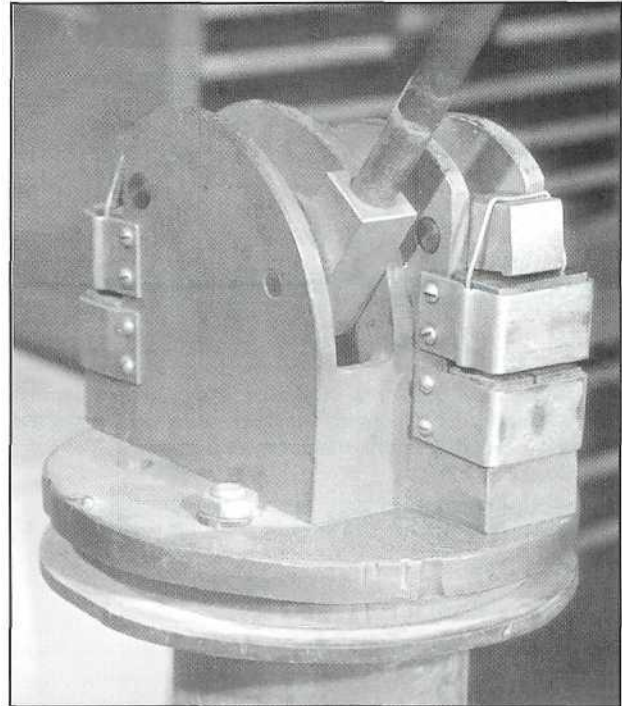

Figure 2-56. Sheet metal shrinkers and stretchers work on the principle of clamping the sheet metal between two jaws while moving the jaws together or apart slightly, to compress or expand the material, respectively.

to compress or stretch it somewhat. The material is worked back and forth across the full width of the curve, shrinking or stretching it just a little with each movement of the jaws. [Figure 2-56]

Sandbags

When only one part is to be formed, a heavy canvas bag filled with a good grade of washed sand can serve as a mold. An impression is made in the sand that approximates the desired shape, and the metal is carefully formed into the depression with a round-face plastic mallet. This is strictly a trial and error method of forming, and its results depend upon the skill of the worker and the care that is taken. [Figure 2-57]

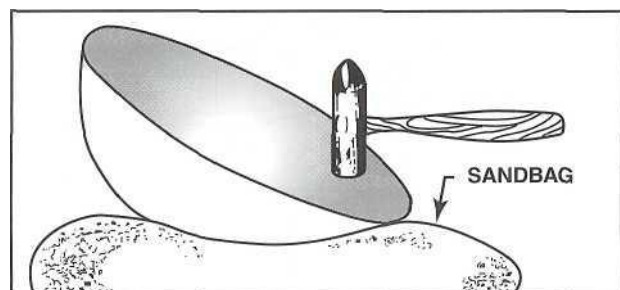

Figure 2-57. A sandbag can be used to form a one-of-a-kind compound curved part.

SPECIAL ASSEMBLY TOOLS

The job of fabricating sheet metal assemblies is made much easier by the use of tools that have been created specifically for working with sheet metal. Since there are so many specialty tools available for sheet metal work, only a select few of the most common types are discussed in this text. However, these tools are representative of those most likely to be encountered when the technician begins performing basic sheet metal repairs to aircraft.

CLAMPS AND SHEET FASTENERS

There are many devices used by technicians to assist them when fabricating sheet metal aircraft components and structures. Some of the most important tools are those used to verify that parts remain in proper alignment during the assembly process. Three of the most common holding tools include Cleco fasteners, C-clamps, and wingnut clamps.

Cleco Fasteners

Before an aircraft sheet metal structure is riveted, it should be temporarily assembled to be sure that all of the parts fit together properly. To provide the closest tolerance fit for rivets, it is standard practice in many operations to drill all of the rivet holes in the individual parts with a pilot drill. The pilot drill is typically smaller than the nominal size of the rivet shank. Eventually, when the parts are mated together, another drill is passed through the pilot holes to open them up to the proper dimensions of the rivet shank. To help prevent the parts from shifting during the final drilling and assembly process, it

is common to use clamping fasteners to hold the parts together until the rivets are installed. This helps ensure alignment of the holes so the rivets seat properly.

One of the most widely used clamping devices is the Cleco fastener, a patented product developed by the Cleveland Pneumatic Tool Company. Although there are other manufacturers of similarly designed clamping devices, the name Cleco is generally associated with these types of tools.

Cleco fasteners consist of a steel body, a spring loaded plunger, two step-cut locking jaws, and a spreader bar. To install or remove a Cleco requires the use of a specially designed pair of pliers. With these pliers, the fastener body is held while pressure is applied to the spring loaded plunger on the top of the Cleco. This forces the pair of locking jaws away from the body and past the spreader bar.

As the jaws pass beyond the bar, they come together, decreasing in diameter. This allows the jaws to be inserted into a rivet hole and then when the pliers are released, the jaws draw back in toward the body past the spreader bar. When the jaws spread apart, the diameter increases, causing the steps in the jaws to grab the underside of the metal. When the jaws retract as far as they can into the body, they apply spring pressure between the locking jaws and the sheet metal, as well as filling the hole diameter with the jaws. Once the pliers are removed from the fastener, a tight grip is formed to help prevent slippage of the material. [Figure 2-58]

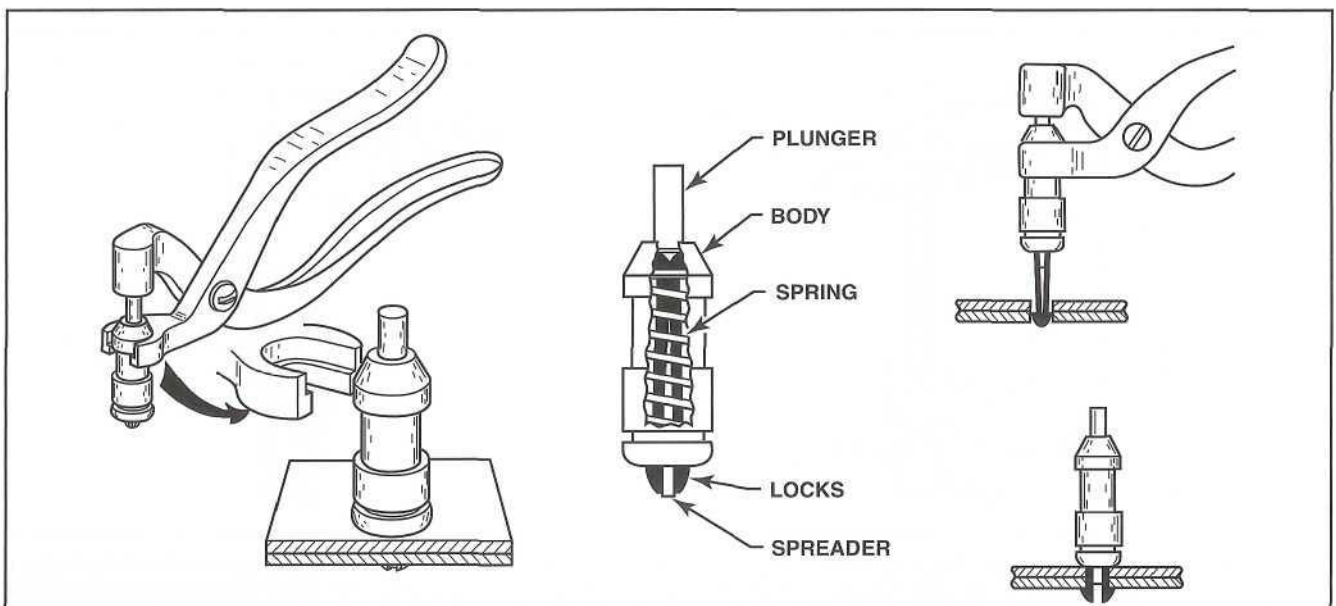

Figure 2-58. Cleco fasteners are used to temporarily hold sheet metal parts together until they are riveted.

Clecos are available in sizes for all the commonly used rivets and even in one larger size. To help identify the designed hole size of Clecos, the body is color coded in one of the

3/32 inch	following colors:	Silver
1/8 inch (-3 diameter rivet)	(-4)	Copper
5/32 inch diameter rivet)	(-5 diameter rivet)	Black
3/16 inch rivet)	(-6 diameter rivet)	Brass
1/4 inch	Wing Nut Fasteners	Copper

Wing nut fasteners are used prior to final assembly of aircraft parts that need to be held extra tight before riveting is started. For example, sheet metal parts under tension around a bend tend to spring apart and may need more pressure to hold the metal together than a Cleco can provide. The wing nut fastener, when hand tightened, will clamp the metal together with more pressure than the spring tension of a Cleco, thus ensuring against any possible slippage. However, a major drawback to using wing nut fasteners is the amount of time required to install and remove them. [Figure 2-59]

C-Clamps

The C-clamp is a tool primarily used by machinists, but has been adapted by technicians working with sheet metal for holding work together on aircraft. It is useful for holding sheet metal in place before beginning the drilling operation. C-clamps are available in many sizes. However, smaller sizes are generally preferred for sheet metal applications to prevent damage to the metal.

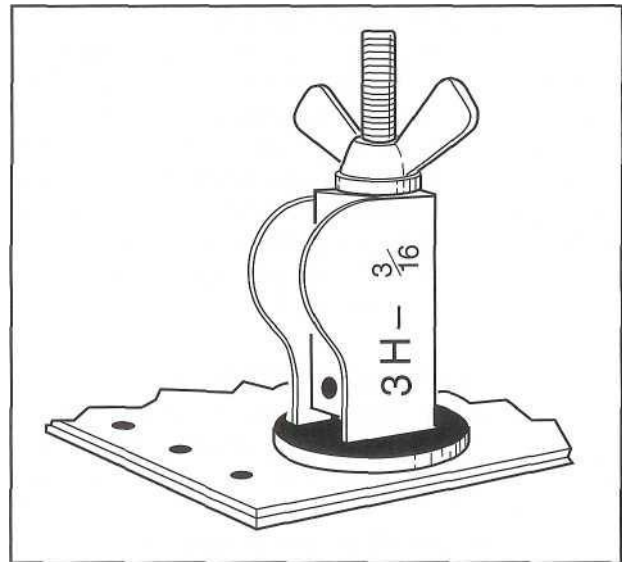

Figure 2-59. Wing nut fasteners are used for temporarily holding sheet metal parts together with more pressure than a Cleco fastener can provide. These fasteners also have the same color coded bodies as Clecos to identify the diameter hole they are designed for.

The C-clamp looks like the letter "C"; hence, its name. The C-frame has a fixed rest on its lower end and a threaded end at the top. The threaded end has a shaft that runs through it with a tee handle running through the shaft, and a floating pad on the end. Before using one of these clamps on sheet metal, it is advisable to place masking tape over each of the pads to help prevent marring of the sheet metal's finish. In addition, before using these clamps, check to make certain the floating pad on the threaded shaft is free to swivel and turn to help prevent marring as the clamp is tightened. [Figure 2-60]

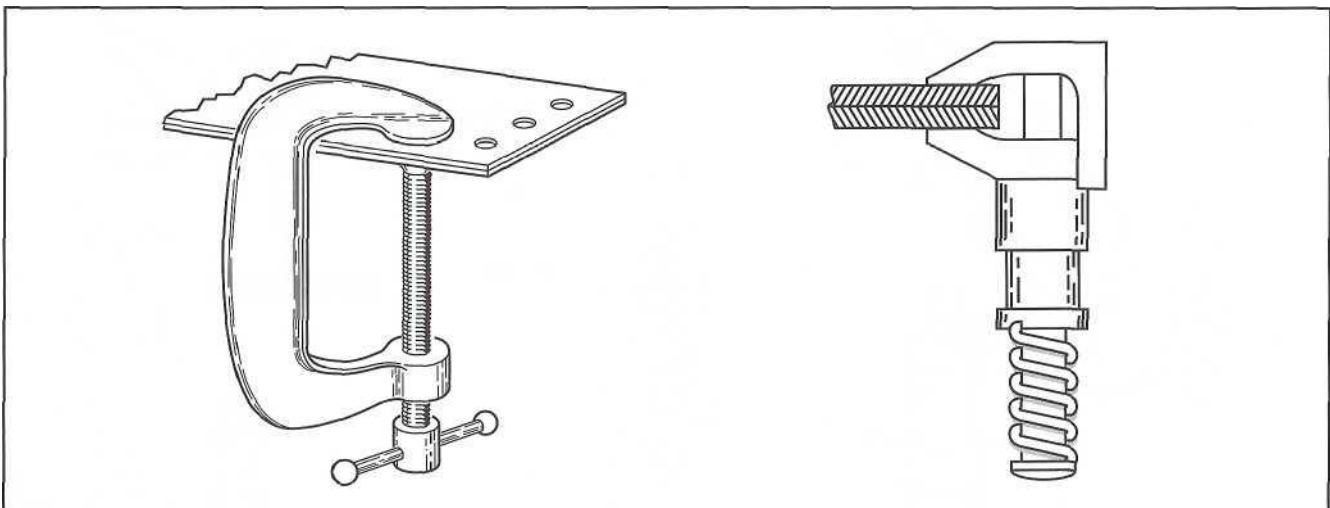

Figure 2-60. C-clamps are useful for holding sheet metal parts together to drill the initial rivet holes as shown on the left. Another device similar to a C-clamp is a side grip clamp, resembling the one shown here on the right. These clamps are spring loaded in the same fashion as a Cleco fastener and are installed and removed using Cleco pliers. Because these clamps are small, they are ideal in tight fitting locations.

HOLE FINDERS

Hole finders are used for locating rivet holes in undrilled skins where a pre-existing hole is hidden by the metal sheet. For example, when an aircraft sheet metal structure is disassembled for a repair, damaged skins may be removed and replaced with new skins while some pre-drilled parts remain on the aircraft. When the new skin is positioned, it may not be possible to see where the holes are located to drill to match the new skin to the pre-drilled parts.

A hole finder consists of two metal straps that are brazed or riveted together at one end. At the opposite end, a pin or pilot extends out from one of the straps while the other strap either has a drill bushing or a center punch type plunger. To use the hole finder, separate the straps and slide the one with the pilot in between the undrilled and drilled parts. When the pilot drops into a rivet hole the second strap with the drill bushing or center punch plunger will be in alignment with the center of the hole. If a drill bushing is used, drill straight through the hole finder to make the new hole in the skin.

On the other hand, if a center punch plunger is used on the hole finder, tap the plunger lightly with a mallet to mark the center of the hole. Once marked, remove the hole finder and drill the part in the normal fashion using the center punch mark as a guide. [Figure 2-61]

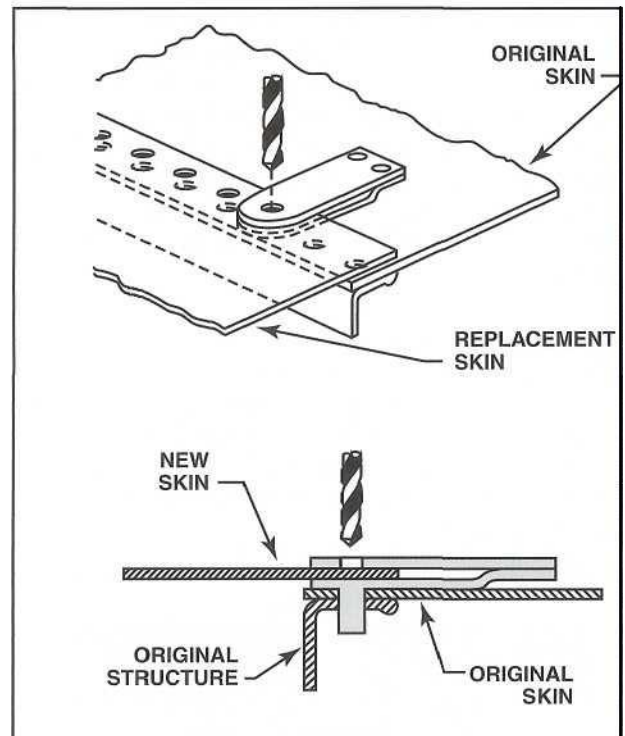

Figure 2-61. A hole finder is used to match holes in an undrilled sheet of metal with existing holes in a hidden part. These tools come equipped with different sized pilots for various rivet diameters. Make sure you do not use a hole finder with too small a pilot, or the drilling accuracy will be diminished and could cause elongation of the pre-existing hole.

CHIP CHASERS

It is sometimes impossible to disassemble skins after drilling a hole, and as a result, there are metal chips that can lodge between the skins that will prevent them from fitting tightly together when a rivet is installed. A tool used to remove these metal chips is commonly called a chip chaser and can be purchased or made from a strip of feeler gauge stock.

When making a chip chaser, use a piece of stock that is thin enough to get between the parts and yet stiff enough to pull out the chips. A strip of .010 inch thick stock is generally considered adequate. Cut a notch near the end of the strip and fasten some sort of handle to the opposite end to make it easy to hold. To use it, just reach in between the skins with the chaser and rake the chips out from between the metal. However, try to pull the parts back so that the chips or the tool does not scratch the finish of the metal. [Figure 2-62]

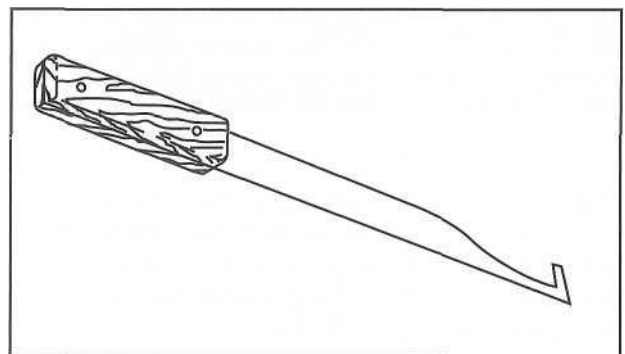

Figure 2-62. A chip chaser can be fashioned to remove drill chips from between sheet metal skins. Another resource for a longer chip chaser is to take an old band saw blade and shear the cutting teeth off its edge. Once cut and shaped, file the edges of the band smooth so that it does not scratch or damage the surface of the metal when used.

STRUCTURAL FASTENERS

The integrity of an aircraft joint depends upon the fasteners selected and used to secure its parts together. However, not all aircraft joints are made

using fasteners. Some joints on newer aircraft are made with composite materials that are held together by adhesives. Although this construction technique is gaining popularity, this method of construction will probably never completely take the place of using fasteners in aircraft assemblies. It is

therefore important for an aircraft technician to be thoroughly familiar with the different types of fasteners that are encountered in industry. Although this section provides general guidelines in the selection and installation of various types of hardware and fasteners, it is always advisable to get acquainted with the fastener manufacturer's technical information before using its product on an aircraft.

SOLID SHANK RIVETS

The solid shank rivet has been used since sheet metal was first utilized in aircraft, and remains the single most commonly used aircraft fastener today. Unlike other types of fasteners, rivets change in dimension to fit the size of a hole during installation. [Figure 2-63]

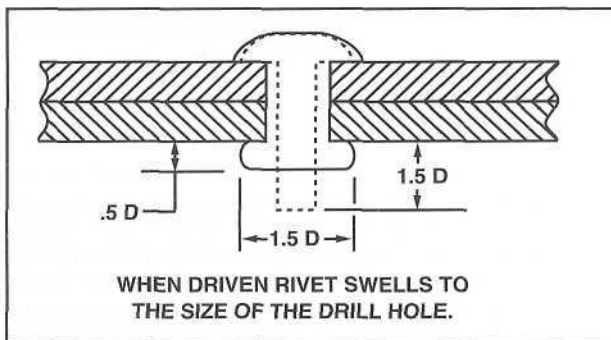

Figure 2-63. Before a rivet is driven, it should extend beyond the base material at least one and a half times the rivet's diameter. Once driven, the rivet shank expands to fill the hole, and the bucktail expands to one and a half times its original diameter. Once the bucktail expands to the appropriate diameter, it should extend beyond the base material by at least one-half the original rivet diameter.

When a rivet is driven, its cross sectional area increases along with its bearing and shearing strengths. Solid shank rivets are available in a variety of materials, head designs, and sizes to accommodate different applications.

RIVET CODES

Rivets are given part codes that indicate their size, head style, and alloy material. Two systems are in use today: the **Air Force - Navy, or AN** system; and the **Military Standards 20 system, or MS20**. While there are minor differences between the two systems, both use the same method for describing rivets. As an example, consider the rivet designation, AN470AD4-5.

The first component of a rivet part number denotes the numbering system used. As discussed, this can either be AN or MS20. The second part of the code

is a three-digit number that describes the style of rivet head. The two most common rivet head styles are the universal head, which is represented by the code 470, and the countersunk head, which is represented by the code 426. Following the head designation is a one- or two-digit letter code representing the alloy material used in the rivet. These codes will be discussed in detail later.

After the alloy code, the shank diameter is indicated in 1/32 inch increments, and the length in increments of 1/16 inch. Therefore, in this example, the rivet has a diameter of 4/32 inch and is 5/16 of an inch long. [Figure 2-64]

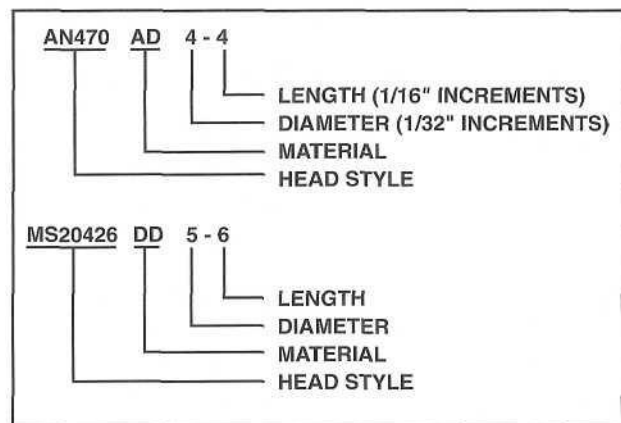

Figure 2-64. Rivet identification numbers indicate head style, material, and size.

The length of a universal head (AN470) rivet is measured from the bottom of the manufactured head to the end of the shank. However, the length of a countersunk rivet (AN426) is measured from the top of the manufactured head to the end of the shank. [Figure 2-65]

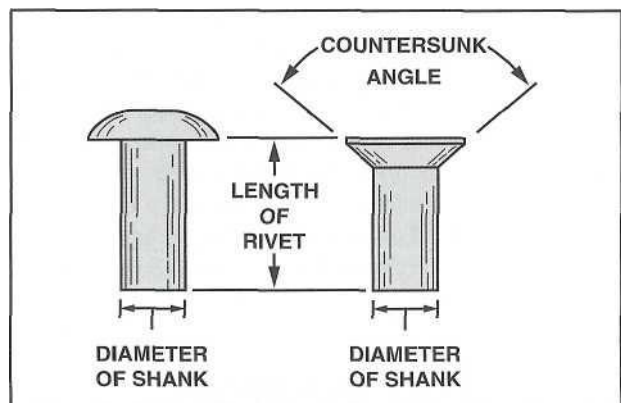

Figure 2-65. Universal and countersunk rivet diameters are measured in the same way, but their length measurements correspond to their grip length.

RIVET HEAD DESIGN

As mentioned, solid shank rivets are available in two standard head styles, **universal** and **countersunk**, or flush. The AN470 universal head rivet now replaces all previous protruding head styles such as AN430 round, AN442 flat, AN455 brazier, and AN456 modified brazier. [Figure 2-66]

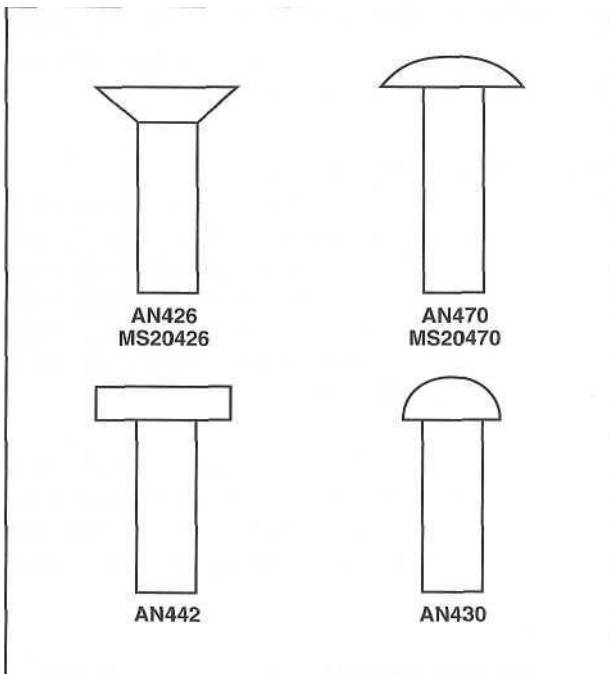

Figure 2-66. The AN470 rivet now replaces almost all other protruding head designs. The round head rivet (AIM430) was used extensively on aircraft built before 1955, while the flat head rivet (AN442) was widely used on internal structures. Flat head rivets are still used for applications requiring higher head strength.

AN426 countersunk rivets were developed to streamline airfoils and permit a smooth flow over an aircraft's wings or control surfaces. However, before a countersunk rivet can be installed, the metal must be countersunk or dimpled. Countersinking is a process in which the metal in the top sheet is cut away in the shape of the rivet head. On the other hand, dimpling is a process that mechanically "dents" the sheets being joined to accommodate the rivet head. Sheet thickness and rivet size determine which method is best suited for a particular application.

Joints utilizing countersunk rivets generally lack the strength of protruding head rivet joints. One reason is that a portion of the material being riveted is cut away to allow for the countersunk head. Another reason is that, when riveted, the gun set may not make direct contact with the rivet

head if the rivet hole was not countersunk or dimpled correctly, resulting in the rivet not expanding to fill the entire hole.

To ensure head-to-gun set contact, it is recommended that countersunk heads be installed with the manufactured head protruding above the skin's surface about .005 to .007 inch. This ensures that the gun set makes direct contact with the rivet head. To provide a smooth finish after the rivet is driven, the protruding rivet head is removed using a microshaver. This rotary cutter shaves the rivet head flush with the skin, leaving an aerodynamically clean surface. [Figure 2-67]

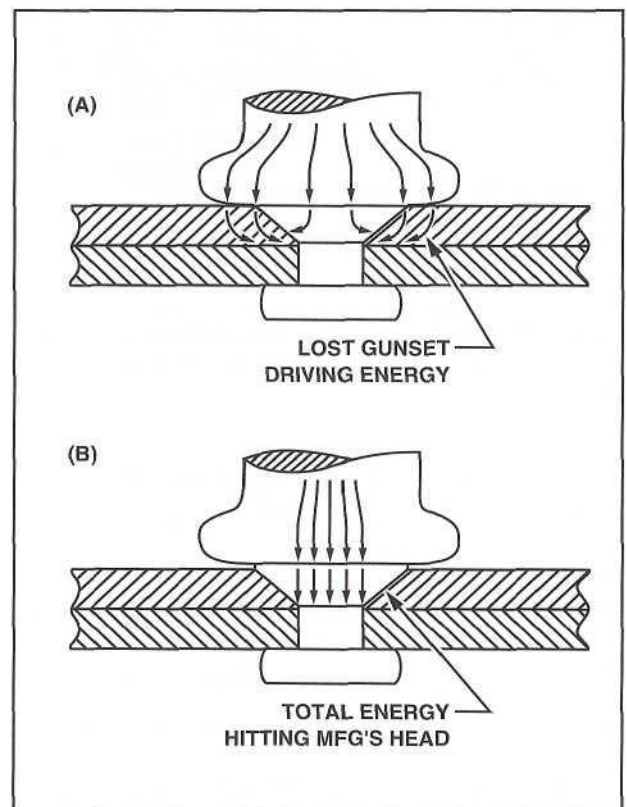

Figure 2-67. (A) If a countersunk rivet is set with the rivet head flush with the metal's surface, some of the gun set's driving energy is lost. (B) However, if the rivet head is allowed to protrude above the metal all of the gun set's energy hits the head, resulting in a stronger joint.

An alternative to leaving the rivet head sticking up slightly is to use the Alcoa crown flush rivet. These rivets have a slightly crowned head to allow full contact with the gun set. To drive these rivets, a mushroom-type rivet set is placed directly on the crown flush head. When the rivet is driven, the gun drives the countersunk head into the countersink, while simultaneously completing rivet expansion.

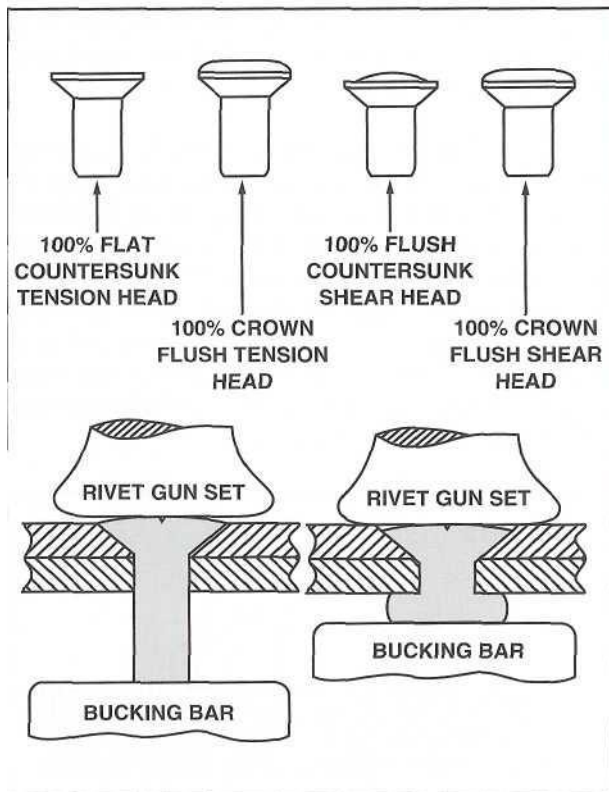

Figure 2-68. The raised head of a crown flush rivet allows greater contact area with a rivet set. This results in a stronger countersunk joint.

This results in a fully cold-worked rivet that needs no microshaving. [Figure 2-68]

RIVET ALLOYS

Most aircraft rivets are made of aluminum alloy. The type of alloy is identified by a letter in the rivet code, and by a mark on the rivet head itself. [Figure 2-69]

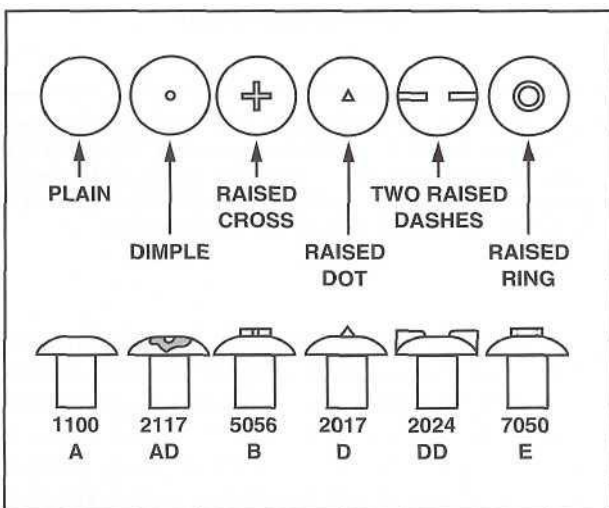

Figure 2-69. Head markings indicate the alloy used in common aircraft rivets.

1100 Aluminum (A)

Rivets made of pure aluminum have no identifying marks on their manufactured head, and are designated by the letter A in the rivet code. Since this type of rivet is made out of commercially pure aluminum, the rivet lacks sufficient strength for structural applications. Instead, 1100 rivets are restricted to nonstructural assemblies such as fairings, engine baffles, and furnishings. The 1100 rivet is driven cold, and therefore, its shear strength increases slightly as a result of cold-working.

2117 Aluminum Alloy (AD)

The rivet alloy 2117-T3 is the most widely used for manufacturing and maintenance of modern aircraft. Rivets made of this alloy have a dimple in the center of the head and are represented by the letters AD in rivet part codes. Because AD rivets are so common and require no heat treatment, they are often referred to as "field rivets."

The main advantage for using 2117-T3 for rivets is its high strength and shock resistance characteristics. The alloy 2117-T3 is classified as a heat-treated aluminum alloy, but does not require reheat-treatment before driving.

5056 Aluminum Alloy (B)

Some aircraft parts are made of magnesium. If aluminum rivets were used on these parts, dissimilar metal corrosion could result. For this reason, magnesium structures are riveted with 5056 rivets, which contain about 5% magnesium. These rivets are identified by a raised cross on their heads and the letter B in a rivet code. The maximum shear strength of an installed 5056-H32 rivet is 28,000 pounds per square inch.

2017 Aluminum Alloy (D)

2017 aluminum alloy is extremely hard. Rivets made of this alloy are often referred to as D rivets, and have been widely used for aircraft construction for many years. However, the introduction of jet engines placed greater demands for structural strength on aircraft materials and fasteners. In response to this, the aluminum industry modified 2017 alloy to produce a new version of 2017 aluminum called the "crack free rivet alloy." The minimum shear strength of the older 2017-T31 rivet alloy is 30 KSI, while that of the new 2017-T3 alloy is 34 KSI.

D-rivets are identified by a raised dot in the center of their head and the letter D in rivet codes. Because

ALLOY	LETTER	HEAD MARKING	DRIVEN CONDITION	POUNDS IN KSI
1100	A	PLAIN	1100-F	9.5
2117	AD	DIMPLE	2117T3	30
5056	B	RAISED CROSS	5056H32	28
2017	D	RAISED DOT	2017T31	34
2017	D	RAISED DOT	2017T3	38
2024	DD	TWO RAISED DASHES	2024T31	41
7050	E	RAISED RING	7050T73	43

NOTE: $KSI = \frac{psi}{1000}$ (e.g. 30 KSI = 30,000 psi)

Figure 2-70. Different rivet alloys produce different shear strengths in their driven condition.

D-rivets are so hard, they must be heat-treated before they can be used. [Figure 2-70]

Recall from the study of heat treatments, that when aluminum alloy is quenched after heat treatment, it does not harden immediately. Instead, it remains soft for several hours and gradually becomes hard and gains full strength. Rivets made of 2017 can be kept in this annealed condition by removing them from a quench bath and immediately storing them in a freezer. Because of this, D-rivets are often referred to as icebox rivets. These rivets become hard when they warm up to room temperature, and may be reheat-treated as many times as necessary without impairing their strength.

2024 Aluminum Alloy (DD)

DD-rivets are identified by two raised dashes on their head. Like D-rivets, DD-rivets are also called **icebox rivets** and must be stored at cool temperatures until they are ready to be driven. The storage temperature determines the length of time the rivets remain soft enough to drive. For example, if the storage temperature is -30°F , the rivets will remain soft enough to drive for two weeks. When DD-rivets are driven, their alloy designation becomes 2024-T31 because of the work hardening achieved during installation.

7050-T73 Aluminum Alloy (E)

A new and stronger rivet alloy was developed in 1979 called 7050-T73. The letter E is used to designate this alloy, and the rivet head is marked with a raised circle. 7050 alloy contains zinc as the major alloying ingredient, and is precipitation heat-

treated. This alloy is used by the Boeing Company as a replacement for 2024-T31 rivets in the manufacture of the 767 wide-body aircraft.

Corrosion-Resistant Steel (F)

Stainless steel rivets are used for fastening corrosion-resistant steel sheets in applications such as firewalls and exhaust shrouds. They have no marking on their heads.

Monel (M)

Monel rivets are identified with two recessed dimples in their heads. They are used in place of corrosion-resistant steel rivets when their somewhat lower shear strength is not a detriment.

SPECIAL RIVETS

A rivet is any type of fastener that obtains its clamping action by having one of its ends mechanically upset. Conventional solid shank rivets require access to both ends to be driven. However, special rivets, often called blind rivets, are installed with access to only one end of the rivet. While considerably more expensive than solid shank rivets, blind rivets find many applications in today's aircraft industry.

POP RIVETS

Pop rivets have limited use on aircraft and are never used for structural repairs. However, they are useful for temporarily lining up holes. In addition, some "home built" aircraft utilize Pop rivets. They are available in flat head, countersunk head, and modified flush heads with standard diameters of $1/8$, $5/32$, and $3/16$ inch. Pop rivets are made

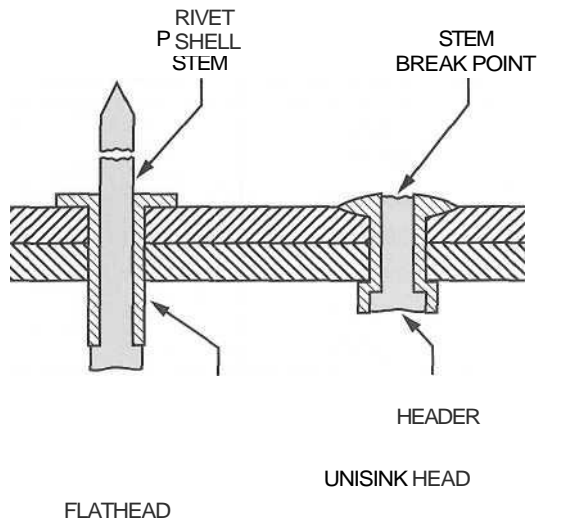

Figure 2-71. Pop rivets are frequently used for assembly and non-structural applications. They must not be used in areas that are subject to moderate or heavy loads.

from soft aluminum alloy, steel, copper, and Monel. [Figure 2-71]

FRICION-LOCK RIVETS

One early form of blind rivet that was the first to be widely used for aircraft construction and repair was the **Cherry friction-lock rivet**. Originally, Cherry friction-locks were available in two styles: hollow shank pull-through, and self-plugging types. The pull-through type is no longer common. However, the self-plugging Cherry friction-lock rivet is still used for repairing light aircraft.

Cherry friction-lock rivets are available in two head styles: universal and 100 degree countersunk. Furthermore, they are usually supplied in three standard diameters: 1/8, 5/32, and 3/16 inch. However, larger sizes can be specially ordered in sizes up to 5/16 inch. [Figure 2-72]

A friction-lock rivet cannot replace a solid shank rivet, size for size. When a friction-lock is used to replace a solid shank rivet, it must be at least one size (1/32 inch) larger in diameter. This is because a friction-lock rivet loses considerable strength if its center stem falls out due to damage or vibration.

MECHANICAL-LOCK RIVETS

Mechanical-lock rivets were designed to prevent the center stem of a rivet from falling out as a result of the vibration encountered during aircraft operation. Unlike the center stem of a friction-lock rivet, a mechanical-lock rivet permanently locks the stem into place, and vibration cannot shake it loose.

HUCK-LOKS

Huck-Lok rivets were the first mechanical-lock rivets and are used as structural replacements for solid

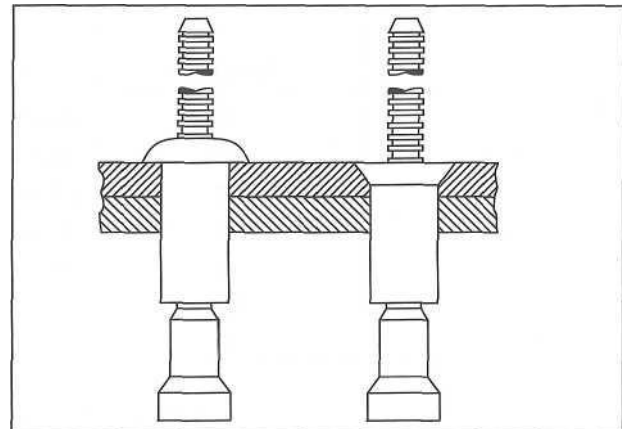

Figure 2-72. The friction-lock rivet assembly consists of a shell and mandrel, or pulling stem. The stem is pulled until the header forms a buck-tail on the blind side of the shell. At this point, a weak point built into the stem shears and the stem breaks off. After the stem fractures, part of it projects upward. The projecting stem is cut close to the rivet head, and the small residual portion remaining in the head is filed smooth.

shank rivets. However, because of the expensive tooling required for their installation, Huck-Loks are generally limited to aircraft manufacturers and some large repair facilities.

Huck-Loks are available in four standard diameters: 1/8, 5/32, 3/16, and 1/4 inch, and come in three different alloy combinations: a 5056 sleeve with a 2024 pin, an A-286 sleeve with an A-286 pin, and a Monel 400 sleeve with an A-286 pin. [Figure 2-73]

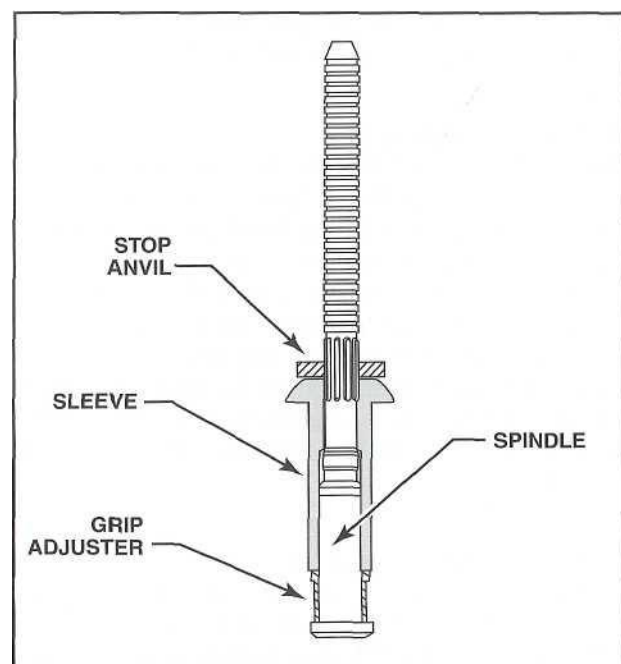

Figure 2-73. Unlike friction-lock rivets, Huck-Loks utilize a lock ring that mechanically locks the center stem in place.

CHERRYLOCKS™

The Cherry mechanical-lock rivet, often called the bulbed CherryLOCK, was developed shortly after the Huck-Lok. Like the Huck-Lok, the CherryLOCK rivet is an improvement over the friction-lock rivet because its center stem is locked into place with a lock ring. This results in shear and bearing strengths that are high enough to allow CherryLOCKS to be used as replacements for solid shank rivets. [Figure 2-74]

CherryLOCK rivets are available with two head styles: 100 degree countersunk, and universal. Like most blind rivets, CherryLOCKS are available with diameters of 1/8, 5/32, and 3/16 inch, with an oversize of 1/64 inch for each standard size. The rivet, or shell, portion of a CherryLOCK may be constructed of 2017 aluminum alloy, 5056 aluminum alloy, Monel, or stainless steel. Installation of

CherryLOCK rivets requires a special pulling tool for each different size and head shape. However, the same size tool can be used for an oversize rivet in the same diameter group.

One disadvantage of a CherryLOCK is that if a rivet is too short for an application, the lock ring sets prematurely, resulting in a malformed shank header. This fails to compress the joint, leaving it in a weakened condition. To avoid this, always use the proper rivet length selection gauge and follow the manufacturer's installation recommendations.

OLYMPIC-LOKS

Olympic-lok blind fasteners are lightweight, mechanically-locking, spindle-type blind rivets. Olympic-loks come with a lock ring stowed on the head. As an Olympic-lok is installed, the ring slips down the stem and locks the center stem to the

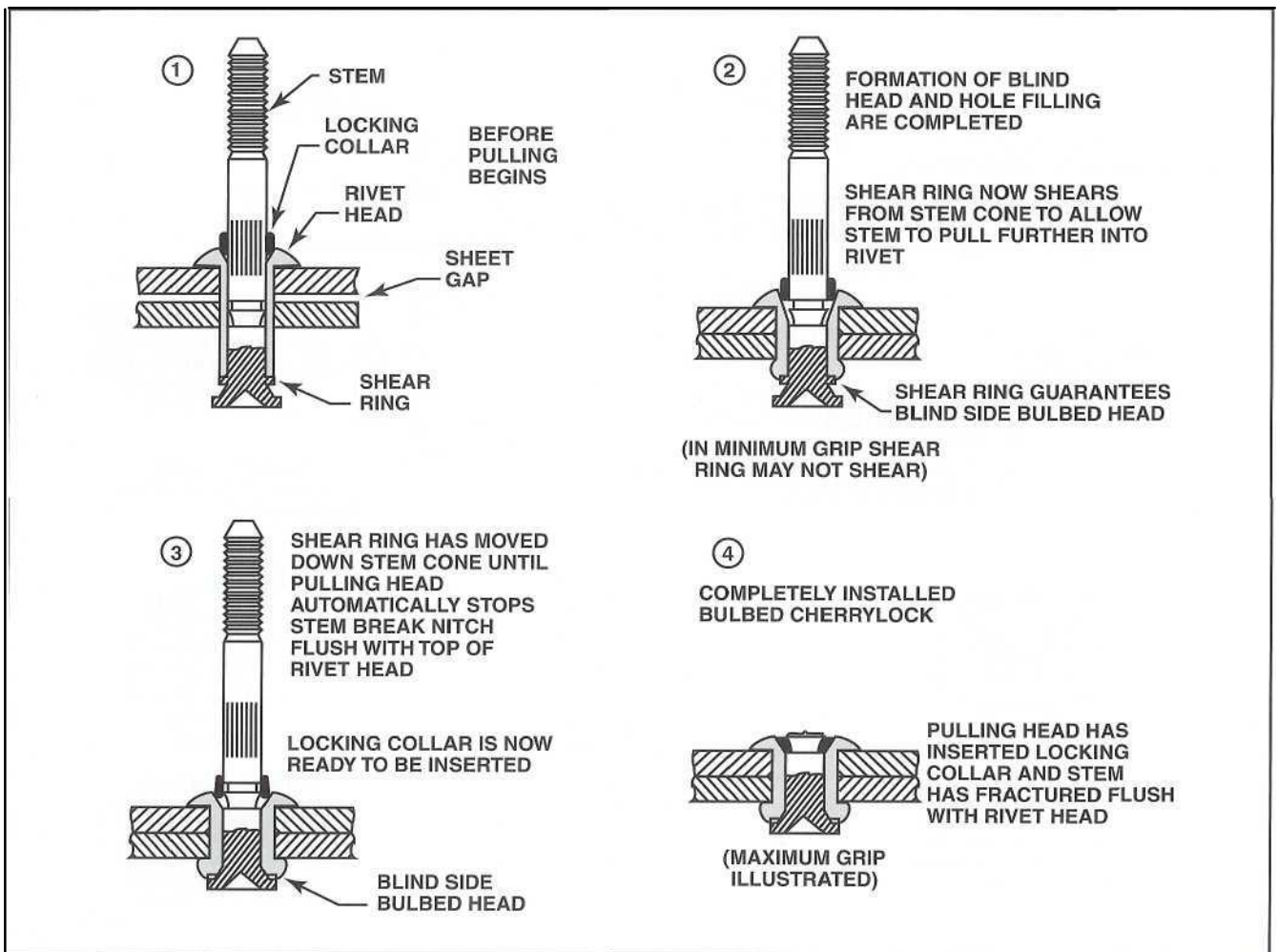

Figure 2-74. (1) As the stem is pulled into the rivet sleeve, a bulb forms on the rivet's blind side that begins to clamp the two pieces of metal together and fill the hole. (2) Once the pieces are clamped tightly together, the bulb continues to form until the shear ring shears and allows the stem to pull further into the rivet. (3) With the shear ring gone, the stem is pulled upward until the pulling head automatically stops at the stem break notch, and the locking collar is ready to be inserted. (4) When completely installed, the locking collar is inserted and the stem is fractured flush with the rivet head.

outer shell. These blind fasteners require a specially designed set of installation tools. [Figure 2-75]

Olympic-lok rivets are made with three head styles: universal, 100 degree flush, and 100 degree flush shear. Rivet diameters of 1/8, 5/32, and 3/16 inch are available in eight different alloy combinations of 2017-T4, A-286, 5056, and Monel.

When Olympic-loks were first introduced, they were advertised as an inexpensive blind fastening system. The price of each rivet is less than the other types of mechanical locking blind rivets, and only three installation tools are required. The installation tools fit both countersunk and universal heads in the same size range.

CHERRYMAX™

The CherryMAX rivet is economical to use and strong enough to replace solid shank rivets, size for size. The economic advantage of the CherryMAX system is that one size puller can be used for the installation of all sizes of CherryMAX rivets. A CherryMAX rivet is composed of five main parts: a pulling stem, a driving anvil, a safe-lock locking collar, a rivet sleeve, and a bulbed blind head. [Figure 2-76]

Available in both universal and countersunk head styles, the rivet sleeve is made from 5056, monel, and inco 600. The stems are made from alloy steel, CRES, and inco X-750. The ultimate shear strength of CherryMAX rivets ranges from 50KSI to 75KSI. Furthermore, CherryMAX rivets can be used at temperatures from 250°F to 1,400°F. They are available

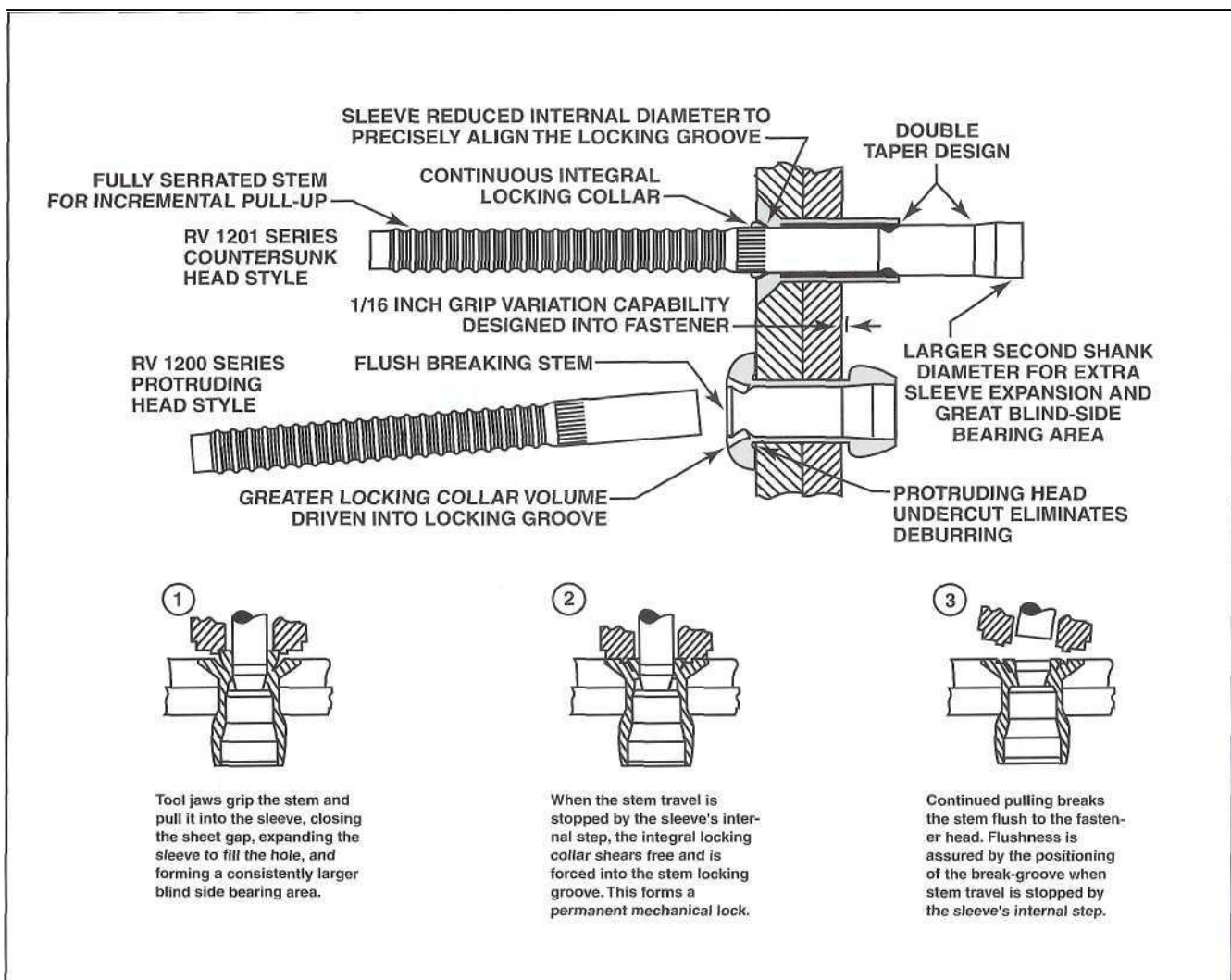

Figure 2-75. (1) Once an Olympic-Lok rivet is inserted into a prepared hole, the stem is pulled into the sleeve, closing any gap between the materials being riveted: filling the hole, and forming a bearing area. (2) When the stem travel is stopped by the sleeve's internal step, the locking collar shears free and is forced into the locking groove. (3) Continued pulling breaks the stem flush with the rivet head.

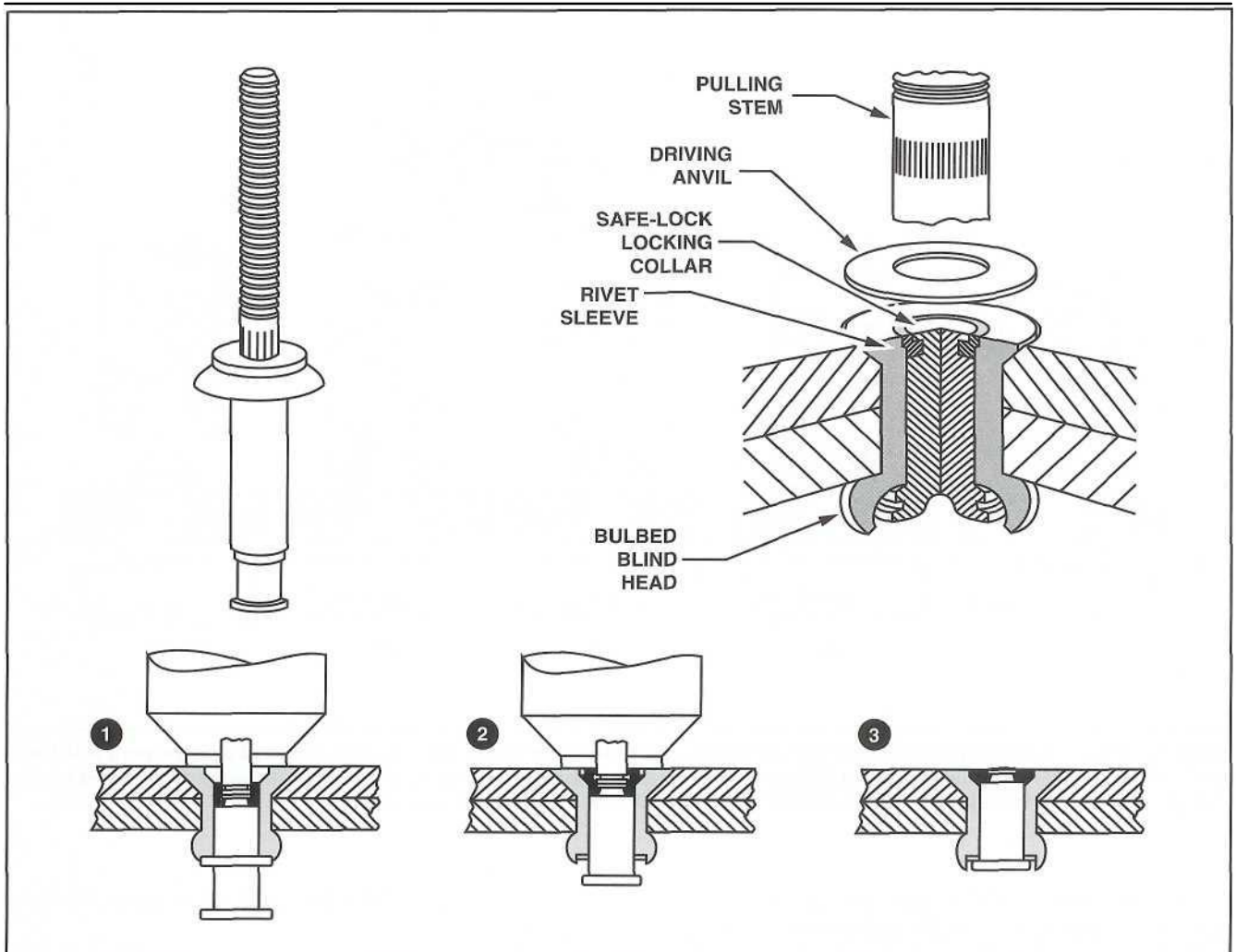

Figure 2-76. (1) As the stem pulls into the rivet sleeve, it forms a large bulb that seats the rivet head, and clamps the two sheets tightly together. (2) As the blind head is completed, the safe-lock collar moves into the rivet sleeve recess. (3) As the stem continues to be pulled, the safe-lock collar is formed into the head recess by the driving anvil, locking the stem and sleeve securely together. Further pulling fractures the stem, providing a flush, burr-free installation.

in diameters of 1/8, 5/32, 3/16 and 1/4 inches, and are also made with an oversize diameter for each standard diameter listed.

Removal Of Mechanical-Lock Rivets

To remove mechanical-lock rivets, first file a flat spot on the rivet's center stem. Once this is done, a center punch is used to punch out the stem so the lock ring can be drilled out. With the lock ring removed, tap out the remaining stem, drill to the depth of the manufactured head, and tap out the remaining shank. All brands of mechanical-lock blind rivets are removed using the same basic technique.

HI-SHEAR RIVETS

One of the first special fasteners used by the aerospace industry was the Hi-Shear rivet. Hi-Shear riv-

ets were developed in the 1940s to meet the demand for fasteners that could carry greater shear loads.

The Hi-Shear rivet has the same strength characteristics as a standard AN bolt. In fact, the only difference between the two is that a bolt is secured by a nut and a Hi-Shear rivet is secured by a crushed collar. The Hi-Shear rivet is installed with an interference fit, where the side wall clearance is reamed to a tolerance determined by the aircraft builder. When properly installed, a Hi-Shear rivet has to be tapped into its hole before the locking collar is swaged on.

Hi-Shear rivets are made in two head styles: flat and countersunk. As the name implies, the Hi-Shear rivet is designed especially to absorb high shear loads. The Hi-Shear rivet is made from steel alloy

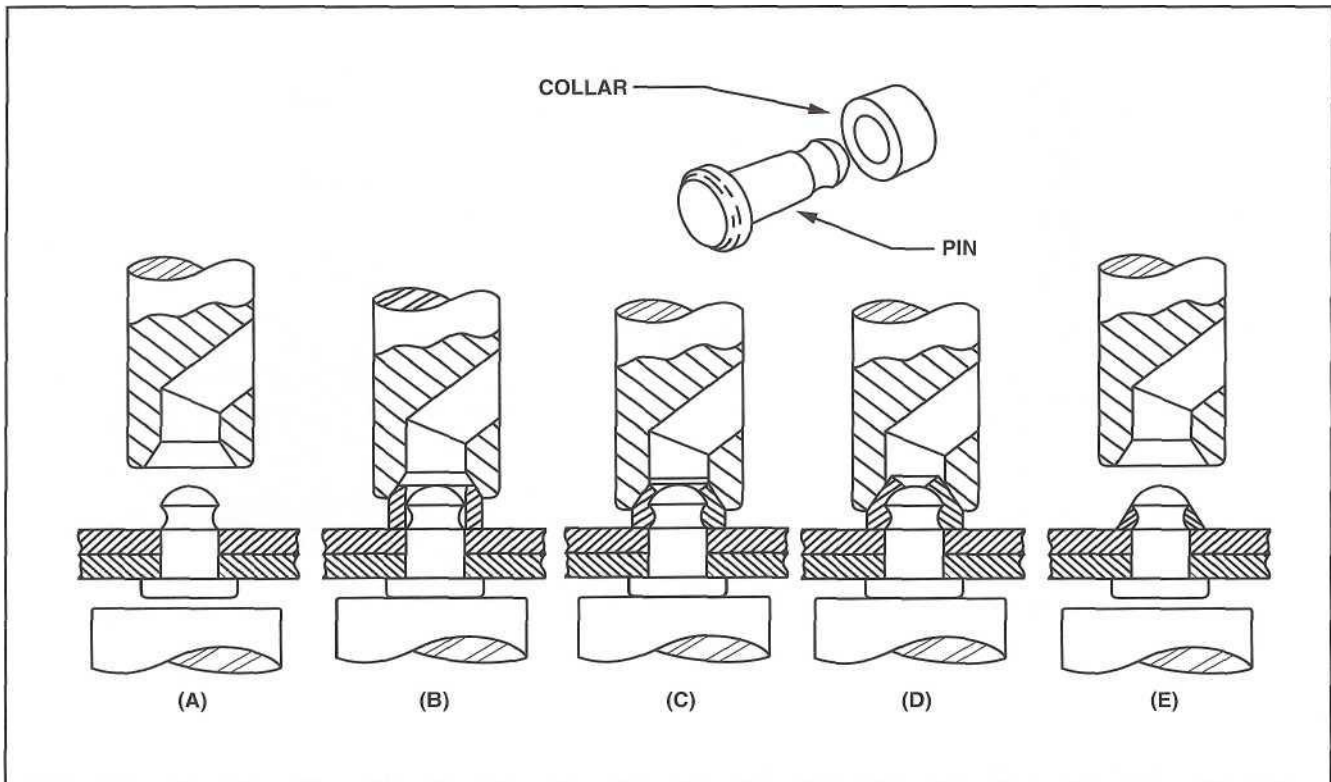

Figure 2-77. (A) A bucking bar and rivet gun are used to install Hi-Shear rivets. (B) A collar is placed over the pin's small end. (C) The rivet gun forces the collar over the pin. (D) The gun set drives the collar onto the rivet pin and cuts off excess material. (E) When the collar is fully driven, excess collar material is ejected from the gun set.

having the same tensile strength as an equal size AN bolt. The lower portion of its shank has a specially milled groove with a sharp edge that retains and finishes the collar as it is swaged into the locked position. [Figure 2-77]

SPECIAL FASTENERS

Many special fasteners have the advantage of producing high strength with light weight and can be used in place of conventional AN bolts and nuts. When a standard AN nut and bolt assembly is tightened, the bolt stretches and its shank diameter decreases, causing the bolt to increase its clearance in the hole. Special fasteners eliminate this change in dimension because they are held in place by a collar that is squeezed into position instead of being screwed on like a nut. As a result, these fasteners are not under the same tensile loads that are imposed on a bolt during installation.

LOCK BOLTS

Lock bolts are manufactured by several companies and conform to Military Standards. These standards describe the size of a lock bolt's head in relation to its shank diameter, as well as the alloy used. Lock bolts are used to permanently assemble two materi-

als. They are lightweight, and as strong as standard bolts.

There are three types of lock bolts used in aviation: the pull-type lock bolt, the blind-type lock bolt, and the stump-type lock bolt. The pull-type lock bolt has a pulling stem on which a pneumatic installation gun fits. The gun pulls the materials together and then drives a locking collar into the grooves of the lock bolt. Once secure, the gun fractures the pulling pin at its break point. The blind-type lock bolt is similar to most other types of blind fasteners. To install a blind-type lock bolt, it is placed into a blind hole and an installation gun is placed over the pulling stem. As the gun pulls the stem, a blind head forms and pulls the materials together. Once the materials are pulled tightly together, a locking collar locks the bolt in place and the pulling stem is broken off. Unlike other blind fasteners that typically break off flush with the surface, blind lock bolts protrude above the surface.

The third type of lock bolt is the stump-type lock bolt, and is installed in places where there is not enough room to use the standard pulling tool. Instead, the stump-type lock bolt is installed using

an installation tool similar to that used to install Hi-Shear rivets. [Figure 2-78]

Lock bolts are available for both shear and tension applications. With shear lock bolts, the head is kept thin and there are only two grooves provided for the locking collar. However, with tension lock bolts, the head is thicker and four or five grooves are provided to allow for higher tension values. The locking collars used on both shear and tension lock bolts are color coded for easy identification. [Figure 2-79]

HI-LOKS

Hi-Lok bolts are manufactured in several different alloys such as titanium, stainless steel, steel, and aluminum. They possess sufficient strength to withstand bearing and shearing loads, and are available with flat and countersunk heads.

A conventional Hi-Lok has a straight shank with standard threads. Although wrenching lock nuts are usually used, the threads are compatible with standard AN bolts and nuts. To install a Hi-Lok, the hole is first drilled with an interference fit. The Hi-Lok is then tapped into the hole and a shear collar is installed using either specially prepared tools or a simple Allen and box end wrench. Once the collar is tightened to the appropriate torque value, the wrenching

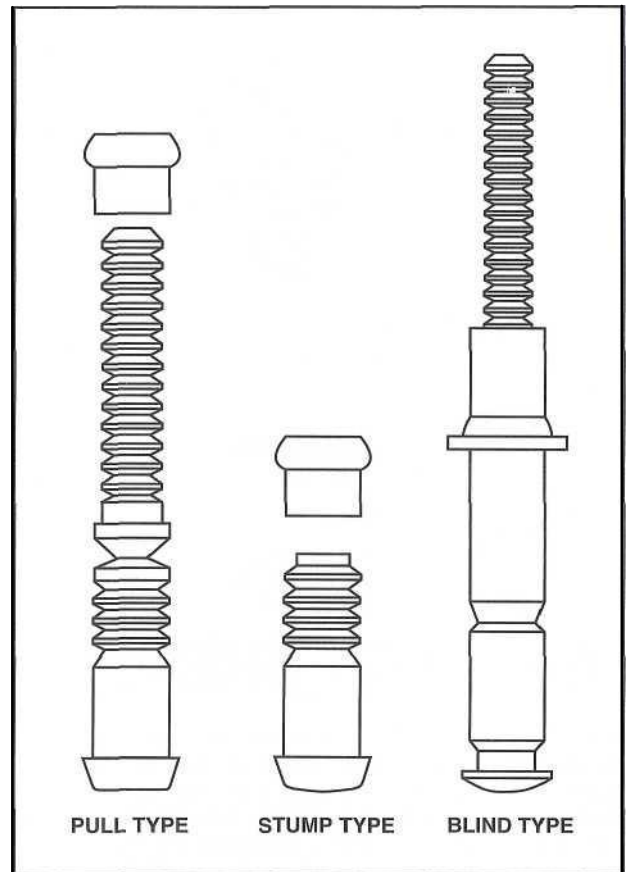

Figure 2-78. Lock bolts are classified as pull type, stump type, and blind type. The bolt used for a particular application depends primarily on access to the work area.

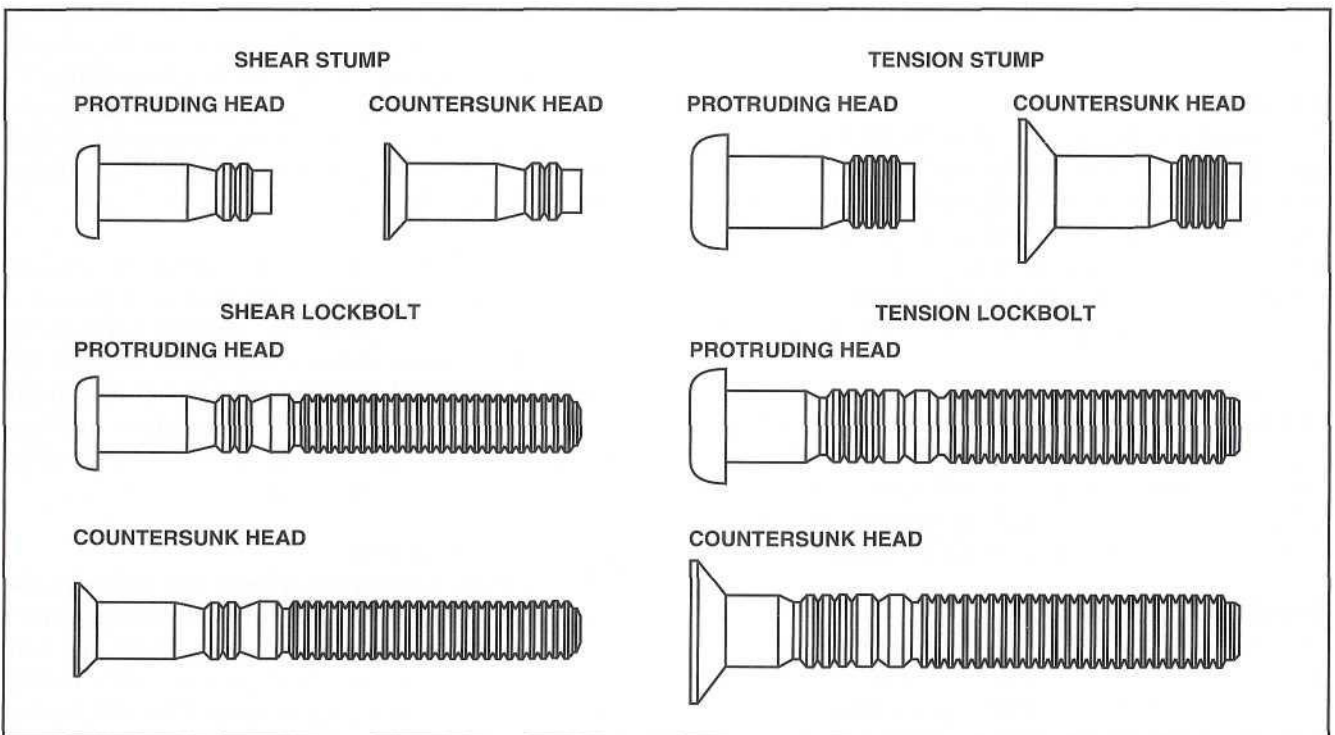

Figure 2-79. As shown here, both the shear and tension type lock bolts come in a variety of sizes with multiple head styles.

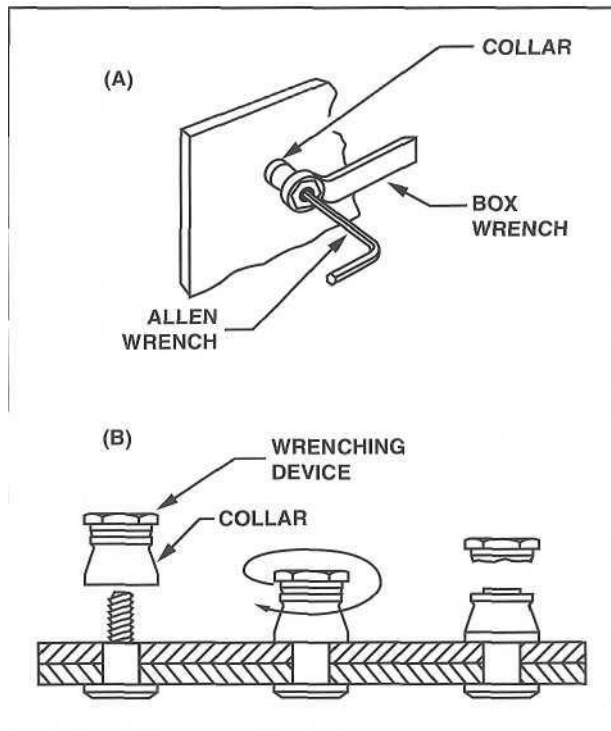

Figure 2-80. (A) An Allen wrench holds a Hi-Lok bolt in place while a combination wrench is used to tighten the shear nut. (B) Once a Hi-Lok is installed, the collar is installed and tightened. When the appropriate torque value is obtained, the wrenching device shears off, leaving the collar.

device shears off leaving only the locking collar. [Figure 2-80]

HI-LITE FASTENERS

The Hi-Lite fastener is similar to the Hi-Lok except that it is made from lighter materials and has a shorter transition from the threaded section to the shank. Furthermore, the elimination of material between the threads and shank yields an additional weight saving, with no loss of strength. The Hi-Lite's main advantage is its excellent strength to weight ratio.

Hi-Lites are available in an assortment of diameters ranging from 3/16 to 3/8 inch. They are installed either with a Hi-Lok locking collar, or by a swaged collar such as the lock bolt. In either case, the shank diameter is not reduced by stretch torquing.

CHERRYBUCK RIVETS

The CherryBUCK is a one-piece special fastener that combines two titanium alloys which are bonded together to form a strong structural fastener. The head and upper part of the shank of a CherryBUCK is composed of 6AL-4V alloy, while

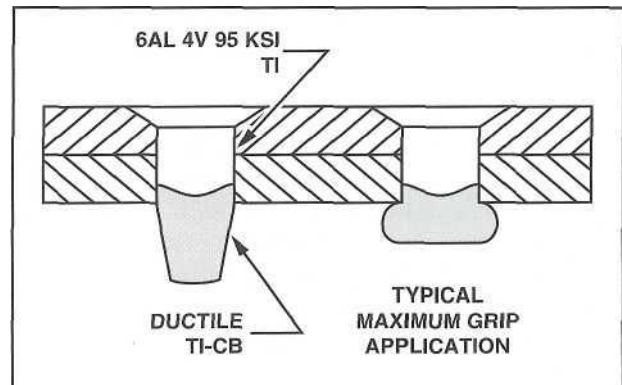

Figure 2-81. CherryBUCK fasteners combine two titanium alloys to produce a one-piece fastener with 95 KSI shear strength.

Ti-Cb alloy is used in the lower shank. When driven, the lower part of the shank forms a buck-tail.

An important advantage of the CherryBUCK is that it is a one piece fastener. Since there is only one piece, CherryBUCKs can safely be installed in jet engine intakes with no danger of foreign object damage. This type of damage often occurs when multiple piece fasteners lose their retaining collars and are ingested into a compressor inlet. [Figure 2-81]

TAPER-LOK FASTENER

Taper-Loks are the strongest special fasteners used in aircraft construction. Because of its tapered shape, the Taper-Lok exerts a force on the conical walls of a hole, much like a cork in a wine bottle. To a certain extent, a Taper-Lok mimics the action of a driven solid shank rivet, in that it completely fills the hole. However, a Taper-Lok does this without the shank swelling.

When a washer nut draws the Taper-Lok into its hole, the fastener pushes outward and creates a tremendous force against the tapered walls of the hole. This creates radial compression around the shank and vertical compression lines as the metals are squeezed together. The combination of these forces generates strength unequalled by any other type of fastener. [Figure 2-82]

HI-TIGUE FASTENERS

The Hi-Tigue fastener has a bead that encircles the bottom of its shank and is a further advancement in special fastener design. This bead preloads the hole it fills, resulting in increased joint strength. During installation, the bead presses against the side wall of the hole, exerting a radial force, which strengthens the surrounding area. Since it is preloaded, the joint

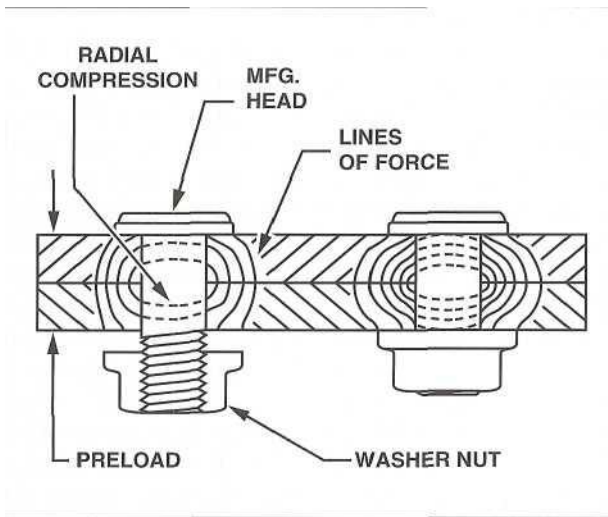

Figure 2-82. The hole for a Taper-Lok is made with a special tapered drill. Once a Taper-Lok is installed and a washer nut is tightened, radial compression forces and vertical compression forces combine to create an extremely strong joint.

is not subjected to the constant cyclic action that normally causes a joint to become cold-worked and eventually fail.

Hi-Tigue fasteners are produced in aluminum, titanium, and stainless steel alloys. The collars are also composed of compatible metal alloys and are available in two types: sealing and non-sealing. As with Hi-Loks, Hi-Tigues can be installed using an Allen and combination wrench. [Figure 2-83]

JO-BOLTS

Jo-Bolts are patented high-strength structural fasteners that are used in close-tolerance holes where strength requirements are high, but physical clearance precludes the use of standard AN, MS, or NAS bolts.

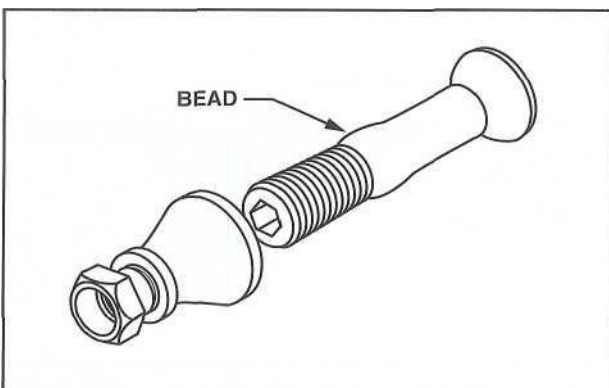

Figure 2-83. A Hi-Tigue fastener features a subtly shaped bead at the threaded end of the shank. This bead preloads the hole it is inserted into, thereby strengthening the joint.

The hole for a Jo-Bolt is drilled, reamed, and countersunk before the Jo-Bolt is inserted, and held tightly in place by a nose adapter of either a hand tool or power tool. A wrench adapter then grips the bolt's driving flat and screws it up through the nut. As the bolt pulls up, it forces a sleeve up over the tapered outside of the nut and forms a blind head on the inside of the work. When driving is complete, the driving flat of the bolt breaks off. [Figure 2-84]

Removal Of Special Fasteners

Special fasteners that are locked into place with a crushable collar are easily removed by splitting the collar with a small cape chisel. After the collar is split, knock away the two halves and tap the fastener from the hole. Fasteners that are not damaged during removal can be reused using new locking

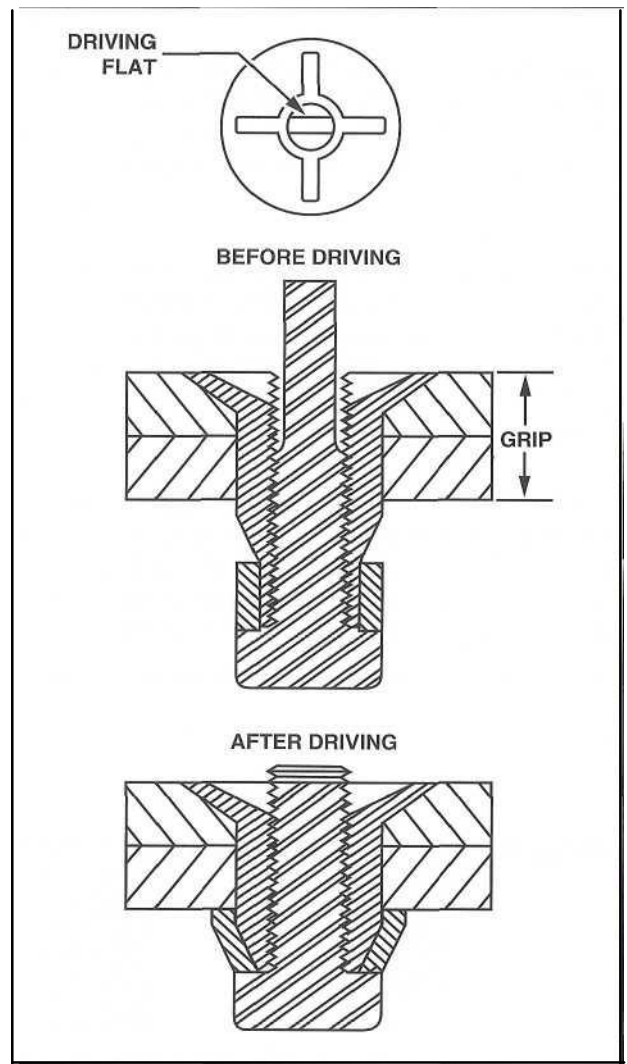

Figure 2-84. Once a Jo-Bolt is inserted into a hole, the bolt is rotated, causing the nut to pull up to the metal. As the nut moves upward, a sleeve is forced over the tapered end of the bolt. This creates a blind head that holds the joint together.

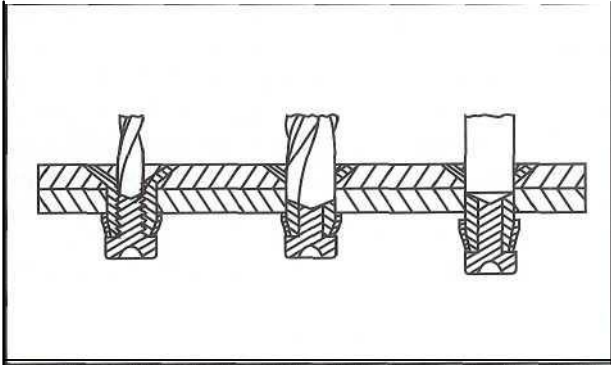

Figure 2-85. Remove flush-type Jo-Bolts by first drilling a pilot hole into the bolt slightly deeper than the inside of the head of the nut. Then, using a twist drill of the same size, drill to the depth of the pilot hole. Drive the shank and blind head from the hole using a pin punch of the proper size.

collars. The removal techniques of certain special fasteners are basically the same as those used for solid shank rivets. However, in some cases, the manufacturer may recommend that a special tool be used.

Removal of Taper-Loks, Hi-Loks, Hi-Tigues, and Hi-Lites requires the removal of the washer-nut or locking collar. Both are removed by turning them with the proper size box end wrench or a pair of vise-grips. After removal, a mallet is used to tap the remaining fastener out of its hole.

To remove a Jo-Bolt, begin by drilling through the nut head with a pilot bit, followed by a bit the same size as the bolt shank. Once the nut head is removed, a punch is used to punch out the remaining portion of the nut and bolt. [Figure 2-85]

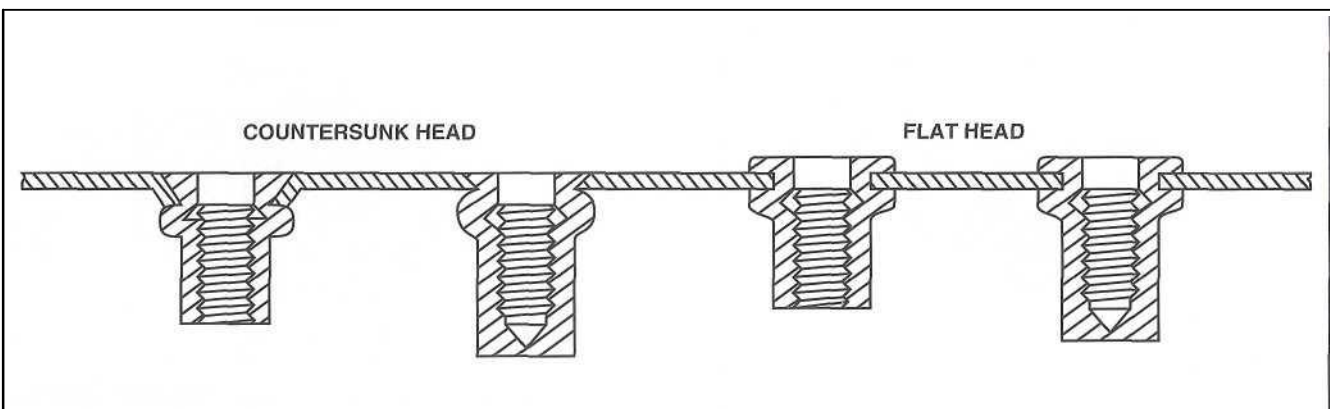

Figure 2-86. Rivnuts are commonly available with flat heads and with 100 degree countersunk heads. Countersunk head Rivnuts are made with both .048 inch and .063 inch head thickness, with the thinner head used when it is necessary to install a Rivnut in a machine countersunk hole in thin material. Closed-end Rivnuts are available for installation in a pressurized structure or sealed compartment, such as a fuel tank.

THREADED RIVETS/RIVNUTS

Goodrich Rivnuts were developed by the B.F. Goodrich Company to attach rubber deicer boots to aircraft wing and tail surfaces. To install a Rivnut, a hole is drilled in the skin to accommodate the body of the Rivnut, and a special cutter is used to cut a small notch in the circumference of the hole. This notch locks the Rivnut into the skin to prevent it from turning when it is used as a nut. A Rivnut of the proper grip length is then screwed onto a special puller and inserted into the hole with a key, or protrusion, aligned with the key-way cut in the hole. When the handle of the puller is squeezed, the hollow shank of the Rivnut upsets and grips the skin. The tool is then unscrewed from the Rivnut, leaving a threaded hole that accepts machine screws for attaching a de-icer boot. [Figure 2-86]

ACCESS PANEL AND COWLING FASTENERS

Turn-lock fasteners are used to secure inspection plates, doors, cowlings, and other removable panels on aircraft. The most desirable feature of these fasteners is that they permit quick and easy removal or opening of access panels for inspection and servicing purposes. Turn-lock fasteners are produced and supplied by a number of manufacturers under various trade names. Some of the most commonly used are the Dzus, Airloc, and Camlock.

DZUS FASTENERS

Cowling and other inspection access doors, that must be opened or removed frequently, can be secured with Dzus fasteners that require only a quarter of a turn to lock or unlock. With a Dzus fastener, a hard spring-steel wire is riveted across an opening on a fixed part of the fuselage, while a stud

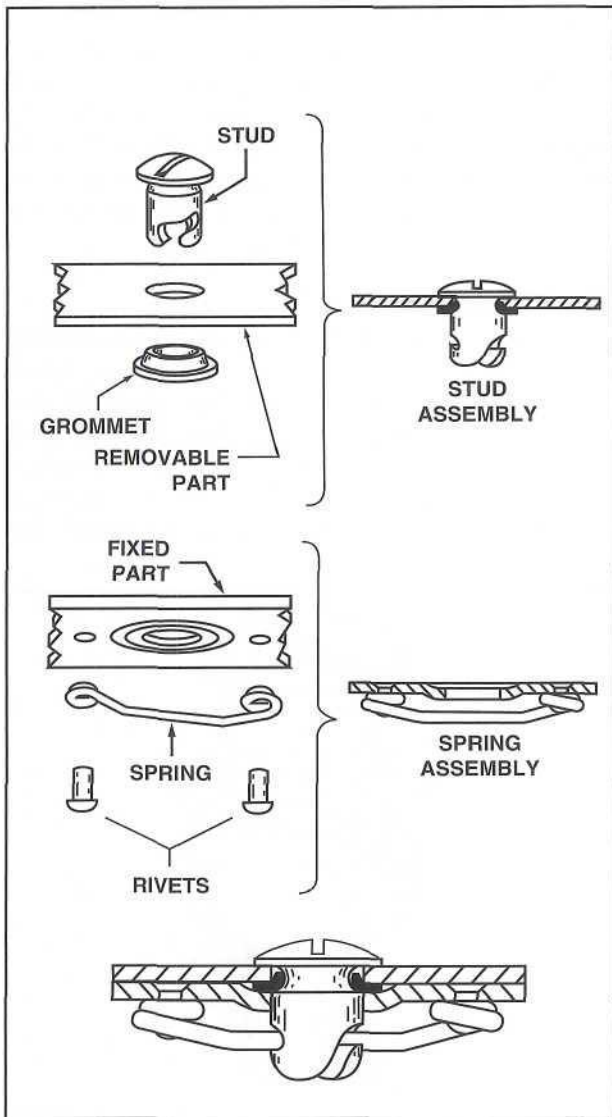

Figure 2-87. With a standard Dzus fastener, a slotted stud engages a spring mounted to the fuselage. As the stud is turned one quarter turn, the fastener locks into place by straddling and securing to the spring.

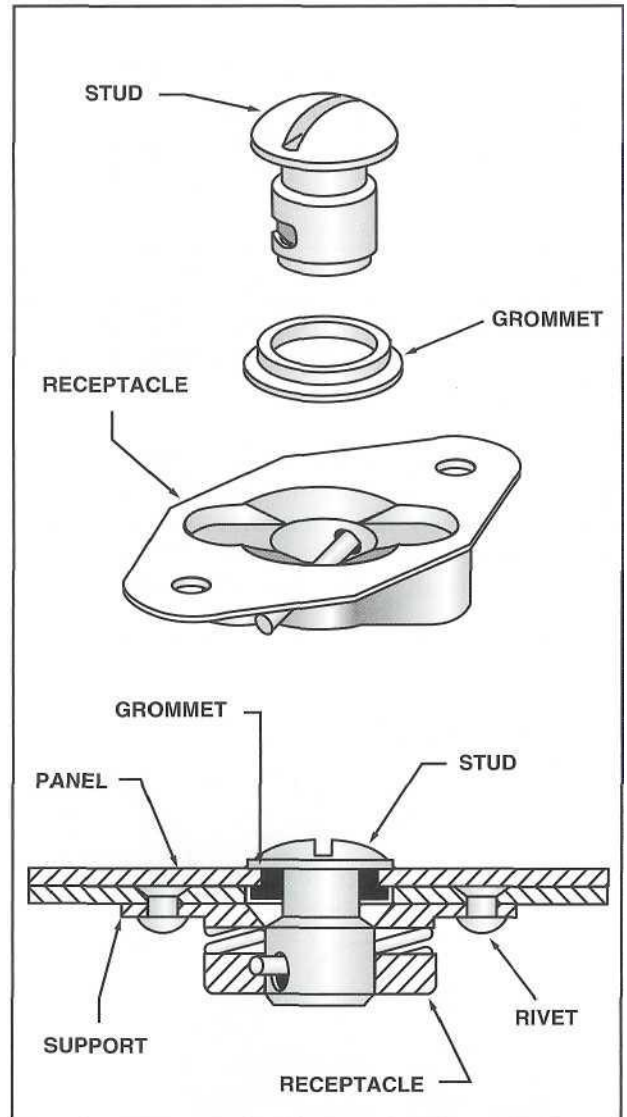

Figure 2-88. The receptacle of a receptacle-type Dzus fastener guides the stud to the exact location it needs to be prior to engaging the spring.

is mounted on the access panel and secured by a metal grommet. Turning the stud one-quarter pulls the stud down by straddling the spring into a beveled slot cut into the stud. As the stud reaches a locked position, the spring drops into a recess in the slot. [Figure 2-87]

When something is fastened with Dzus fasteners, care must be taken that the stud in every fastener straddles each of the springs rather than passing beside them. To ensure that all of the fasteners are properly locked, the heads of the fasteners should all line up once secured. Furthermore, when a Dzus fastener is fastened, a distinct click is heard when the spring drops into the recess of the slot in the

locked position. To aid in ensuring that no stud misses the spring. Special receptacle-type Dzus fasteners are available that guide the stud over the spring. [Figure 2-88]

To aid in identifying the size and head style of a Dzus fastener, the manufacturer provides a cast letter and number in the head of each stud. The letters designate the head style as being a raised oval head, flush head, or winged head. The winged head style allows for turning the fastener without the use of hand tools. On the other hand, the raised oval and flush head styles, usually require a slotted or Phillips style screwdriver to be used to turn the fastener. The numbers following the head style letter

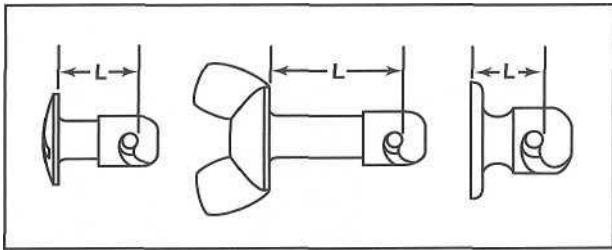

Figure 2-89. Stud lengths of raised oval head and winged Dzus fasteners are measured from the bottom of the head to the bottom of the locking slot, whereas flush head styles are measured from the top of the head to the bottom of the locking slot.

designate the diameter and length of the stud. The first number indicates the diameter of the stud body measured in 1/16 inch increments, while the second number designates the length of the stud measured in hundredths of an inch. [Figure 2-89]

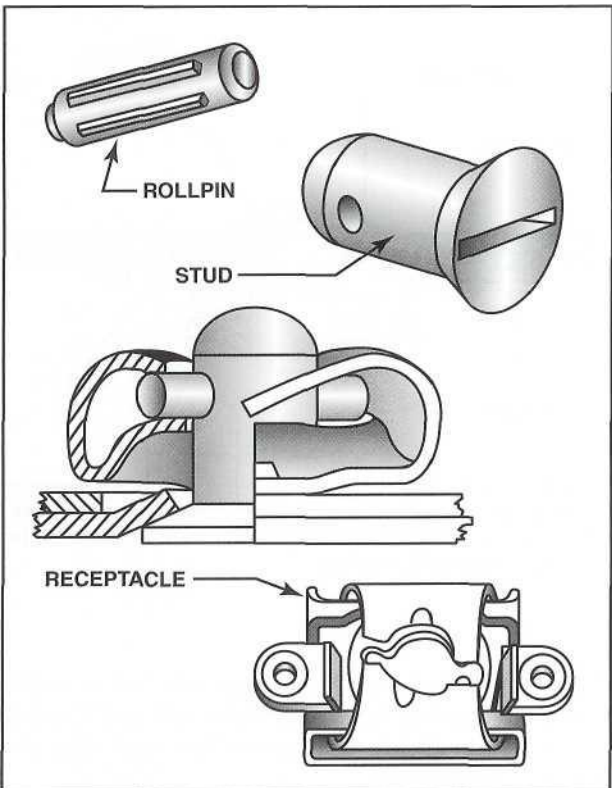

Figure 2-90. Airloc cowling fasteners are similar to Dzus fasteners and are used in many of the same applications.

AIRLOC FASTENER

An Airloc fastener consists of a steel stud and cross-pin in a removable cowling or door and a sheet spring-steel receptacle in the stationary member. To lock this type of fastener, the stud slips into the receptacle and is rotated one-quarter. The pin drops into an indentation in the receptacle spring and holds the fastener locked. [Figure 2-90]

CAMLOCK FASTENER

The stud assembly of a Camlock fastener consists of a housing containing a spring and a stud with a steel pin. This assembly is held onto the removable portion of the cowling or access door with a metal grommet. The stud fits into a pressed steel receptacle, and a one-quarter turn locks the steel pin in a groove in the bottom of the receptacle. [Figure 2-91]

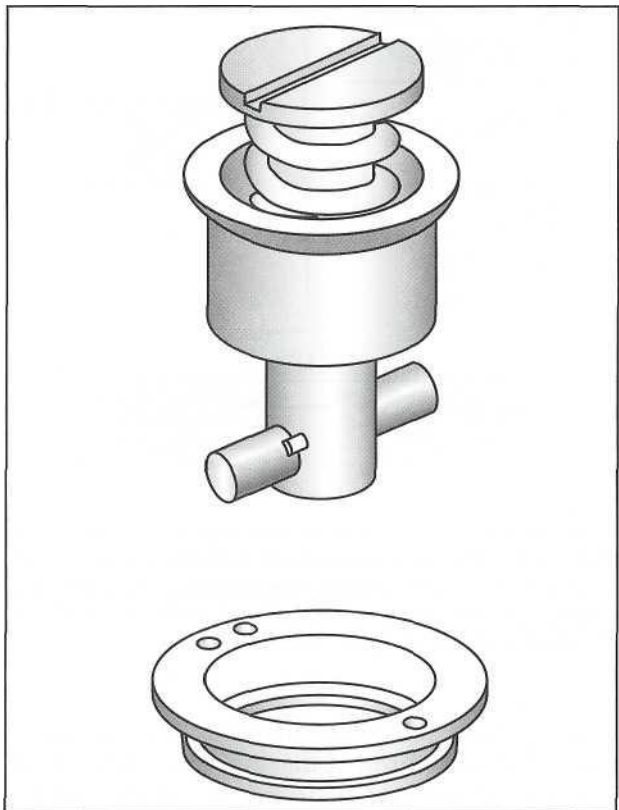

Figure 2-91. With a Camlock cowling fastener, the stud assembly can be inserted when the pin is aligned with the slot in the receptacle.

The selection of sheet metal materials, and proper fabrication techniques is crucial during initial construction of a sheet metal structure, or for its restoration of strength during a repair. In most cases, selection of materials and fabrication processes can be determined by consulting the manufacturer's publications, such as the structural repair or maintenance manuals. However, if the manufacturer does not identify specific materials and fabrication procedures, the technician must use standard industry acceptable techniques to perform sheet metal work.

To aid the technician, many of these standard material identification and fabrication processes are addressed in Advisory Circular 43.13-1B, *Acceptable Methods, Techniques and Practices*. By learning and applying standard practices, the technician can perform satisfactory work to many types of sheet metal structures, even when the manufacturer's information is not available to directly cover the task to be performed.

INSTALLATION OF SOLID RIVETS

A primary task performed by any aircraft maintenance technician working with sheet metal is to install solid shank rivets in structures or components. This involves selecting the proper rivets and installing them in such a way that the maximum structural integrity of the product is attained, as determined by engineering experience with properly installed rivets. Although the concept of installing rivets is a straightforward process, there are a number of aspects that the technician must understand and observe to achieve the optimum performance from the structure or component design.

RIVET SELECTION

When initially fabricating or making a repair to an aircraft structure or component, the technician's primary objective is to obtain the maximum structural integrity and aerodynamic shape. When an aircraft is originally certificated, the acceptance of the design is based on each subsequent aircraft being manufactured to the original design specifications. If an air-

craft is damaged while in service, it is the technician's responsibility to verify that the aircraft is repaired to those original specifications and certification criteria. With any sheet metal structure, the proper preparation and installation of solid shank rivets is paramount in achieving these goals. One of the most critical aspects of sheet metal work is to be able to select the proper rivet for a given application.

As previously discussed in the beginning of this chapter, when a rivet is used for a particular installation, the shear strength of the rivet, as compared to its bearing strength, must be considered. This is especially important when replacing rivets of different types of alloys. For example, if replacing a 2024 rivet with a 2117 rivet, the relative bearing and shear strengths of each rivet should be considered. These strengths can be found in rivet charts. In this case, due to the varying strength characteristics of the two different types of alloys used in the rivets, the smaller 2024 rivet must be replaced with one size larger 2117 rivet to produce the same strength qualities. In many cases, the only course is to use the same type and size rivet originally specified. Bearing and shear strength should usually be nearly the same. However, the bearing strength should be slightly higher to enable the part to fail by shearing the rivets rather than tearing out sections of sheet metal. [Figures 2-92 and 2-93]

The single-shear strength of aluminum alloy rivets is shown in Figure 2-92. From this figure it can be determined that a 1/8 inch diameter AD rivet will support a load of 331 pounds, and a 1/8 inch DD rivet will support a load of 429 pounds before shearing. For double-shear loads, that is, a joint in which three pieces of material are being held together, the values in the chart are doubled. On the other hand, Figure 2-93 shows the bearing strength of 2024-T3 clad aluminum alloy sheets. From the chart, you can determine what the bearing strength of the aluminum sheet will be, given different sheet thickness and rivet diameters. For example, a .040 inch thick 2024-T3 clad sheet will provide 410 pounds bearing strength using a 1/8 inch diameter rivet. If an AD

SINGLE-SHEAR STRENGTH OF ALUMINUM ALLOY RIVETS — POUNDS									
COMPOSITION OF RIVET (ALLOY)	ULTIMATE STRENGTH OF RIVET METAL (POUNDS PER SQUARE INCH)	DIAMETER OF RIVET (INCHES)							
		1/16	3/32	1/8	5/32	3/16	1/4	5/16	3/8
AD 2117	27,000	83	186	331	518	745	1,325	2,071	2,981
D 2017	30,000	92	206	368	573	828	1,472	2,300	3,313
DD 2024	35,000	107	241	429	670	966	1,718	2,684	3,865

DOUBLE-SHEAR IS FOUND BY MULTIPLYING THE NUMBERS IN THE CHART BY TWO

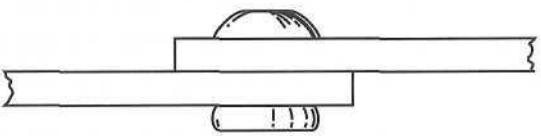

SINGLE SHEAR

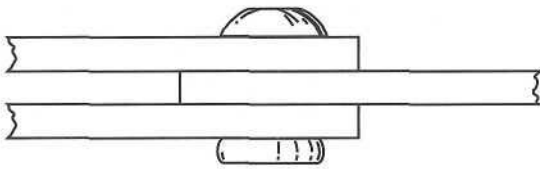

DOUBLE SHEAR

Figure 2-92. The shear strength of a rivet is dependent on its alloy and the diameter of the rivet.

rivet is used, the shear strength of the rivet will be 331 pounds, which is less than the 410 pounds of bearing strength. In this example, the rivet and metal combination would provide a satisfactory joint, in that the rivet would shear in two before damaging the sheet metal.

When charts are not readily available for determining the shear strength of rivets and bearing strength of sheet metal, a general formula can be used to determine the proper diameter rivet for single lap joints. In this formula, the proper diameter rivet is equal to three times the thickness of the thickest

sheet of metal in the joint. For example, if a joint consists of one sheet of aluminum .032 inch thick and another .040 inch thick, the rivet diameter would be equal to 3 x .040 or .120 inch. The closest rivet diameter to this dimension is a -4-diameter rivet, which is .125 inch. Once the proper diameter rivet has been determined, the correct rivet length can be calculated.

To fabricate a properly driven rivet, the width of the bucked head must be equal to one and a half times the rivet's original shank diameter and the height must be one half the original shank diameter. In

THICKNESS OF SHEET (INCHES)	BEARING STRENGTH OF 2024-T3 CLAD ALUMINUM (POUNDS)							
	DIAMETER OF RIVET (INCHES)							
	1/16	3/32	1/8	5/32	3/16	1/4	5/16	3/8
.016	82	123	164	204	246	328	410	492
.020	102	253	205	256	307	410	412	615
.025	128	192	256	320	284	512	640	768
.032	164	145	328	409	492	656	820	984
.040	205	307	410	512	615	820	1,025	1,230
.051	261	391	522	653	784	1,045	1,306	1,568
.064	492	656	820	984	1,312	1,640	1,968
.072	553	738	922	1,107	1,476	1,845	2,214
.091	699	932	1,167	1,398	1,864	2,330	2,796
.125	961	1,281	1,602	1,922	2,563	3,203	3,844
.250	1,921	2,562	3,202	3,843	5,125	6,405	7,686
.500	3,842	5,124	6,404	7,686	10,250	12,090	15,372

Figure 2-93. The bearing strength of sheet metal is dependent on the alloy, thickness of the sheet, and the size of the installed rivet.

order for the bucked head to develop these finished dimensions, the rivet needs to protrude through the metal approximately one and a half times the shank diameter before being driven.

To calculate the proper length, it is necessary to multiply one and a half times the diameter of the rivet and then add the grip length of the material. For the proper dimension rivet in the previous example, the rivet length is determined by multiplying the diameter of the rivet (.125) by one and a half, or 1.5. This provides an answer of .1875. To this number, add the grip length of the metal (.032 + .040) to obtain an overall length of .2575 inches. Once this number is determined, convert the answer into the closest 1/16 inch increment, which in this case, is equal to 1/4 inch for a -4 length rivet. If the rivets in this sample project had universal head styles, the final rivet identification would be MS20470AD4-4. [Figure 2-94]

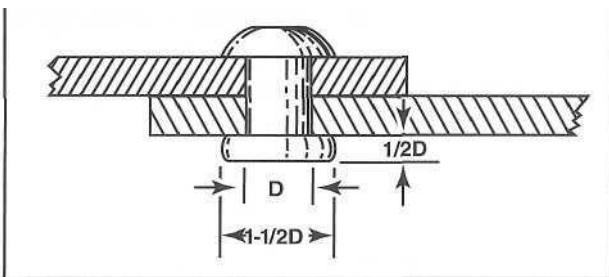

Figure 2-94. A properly formed shop or bucked rivet head will have a diameter of one and a half times the original shank diameter wide, by one half the shank diameter high, as shown in this sketch.

RIVET CUTTERS

To avoid carrying a large assortment of rivet lengths, many shops only purchase longer rivets. For shorter sizes, a rivet cutter can be used to trim the rivets to the desired length. [Figure 2-95]

RIVET LAYOUT PATTERNS

It is important when making a riveted repair that the rivets be installed in such a way that they will develop the maximum strength from the sheet metal. To obtain this strength, not only the rivet and sheet strength must be determined, but the rivet pattern is also a critical factor so the drilled holes do not weaken the joint. This means the spacing between rivets and the distance they remain from the edge of the material cannot be closer than minimum specifications.

RIVETED SHEET METAL STRENGTH

From the previous discussion of sheet metal alloys, it was presented that sheet metal can withstand spe-

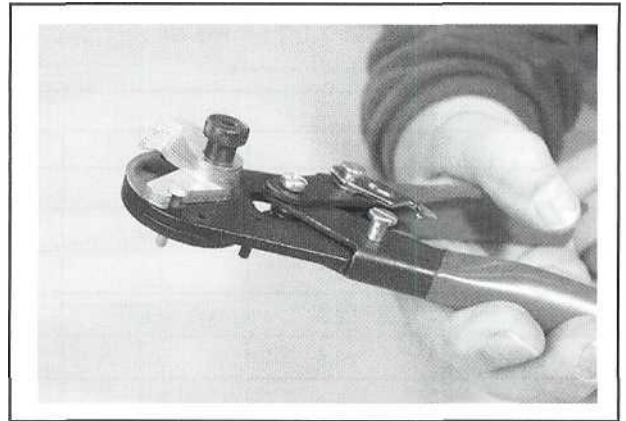

Figure 2-95. Rivet cutters have holes to cut common-sized rivet diameters, and a series of leaves that are rotated into position to shim under the rivet head to vary the shank length.

cific amounts of tensile stress depending on the type and thickness material. In aircraft construction, it is important that sheet metals be able to withstand the minimum tensile stresses when the sheets are used in stressed skin structures. For example, semimonocoque designs rely heavily on the ability of sheet metal skins to carry stresses into a substructure. When an aircraft is designed, engineers determine the amount of load that the sheet metal must carry to provide the desired strength from a structure. If sheet metal skins or components have riveted joints or seams, there must be an adequate number of rivets to carry the load. To determine the proper number of rivets, charts are available to determine the quantity of rivets that must be used for various types and thickness of alloy sheets. [Figure 2-96]

For example, when fabricating a seam in 2024-T3 alclad aluminum that is .040 inch thick, it is necessary to use a minimum of 6.2 1/8 inch diameter rivets per inch of seam width. If the seam is 8 inches wide, it will require 49.6 or 50 rivets to fabricate the seam to withstand the same tensile stresses as the original sheet metal. Additional information regarding the use of these types of charts is covered in the sheet metal repair section of this chapter.

EDGE DISTANCE

It is important when installing rivets that they be placed a certain distance from the edge of the material. If rivets are installed too close to the edge, the sheet metal will tear out instead of shearing the rivet when extreme loads are encountered. Conversely, if the rivets are placed too far away from the edge, the metal sheets can separate, allowing foreign contaminants to enter the joint, ultimately causing corrosion.

Figure 2-96. Charts are available to provide information regarding the number of rivets required in a joint or seam to endure the same amount of tensile strength as sheet metal. The chart in this figure provides information regarding the minimum number of rivets required per inch of width of a joint or seam to restore the strength of stressed sheet metal structures.

An accepted practice is to place the center of a rivet hole no closer than two rivet shank diameters from the edge and no further back than four diameters. With this in mind, it is common to place the center of the rivet hole about two and a half shank diameters away from the edge of the sheet. However, if possible, the rivet edge distance should be the same as the original by matching the previous pattern, or by consulting the manufacturer's design specifications.

PITCH

The distance between adjacent rivets in a row is

called the pitch. To prevent the joint from being weakened by too many holes in a row, the adjacent rivets should be no closer than three diameters to one another. In contrast, to prevent the sheets from separating between rivets, the rivet holes should be no further apart than ten to twelve times the rivet shank diameter. [Figure 2-97]

RIVET GAUGE OR TRANSVERSE PITCH

The distance between rows of rivets in a multi-row layout should be about 75% of the pitch, provided that the rivets in adjacent rows are staggered. If the rivets are not staggered, then the pitch will be the

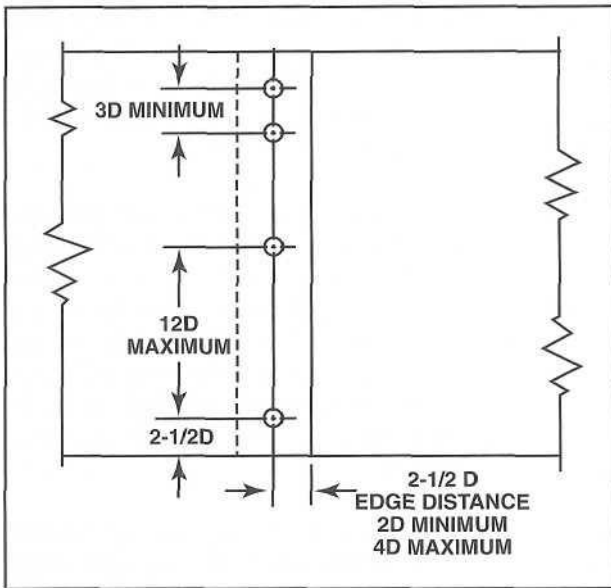

Figure 2-97. Edge distance and rivet pitch are critical to obtaining maximum strength from a riveted repair.

same between rows as it is between rivets in a single row. For most layout patterns, it is most practical to stagger the placement of rivets to reduce the amount of sheet metal that has to be overlapped. In addition, multiple rivet rows are often used to prevent rivets in a single row from becoming too close together, or to improve the cosmetics of a repair.

SAMPLE LAYOUT PATTERN

For a sample layout pattern, assume that you want to join two 3-3/4 inch straps of .040 inch 2024-T3 clad aluminum alloy sheets with 11 MS20470AD4-4 rivets. To install 11 rivets, more than one row will be required, because a single row would cause the rivets to be so close that the joint would be weakened. For this example, assume two rows are used with six rivets in the first row and five in the second. To make a layout pattern, first make two lines to mark off the edge distance of two and a half rivet shank diameters. Since the rivets are 1/8 inch (4/32), the distance will be 5/16 inch from the edge of the sheets. Mark these lines with a soft pencil or felt tip marker so the marks will not scratch the metal. Measure another 5/16 inch up from the ends of these lines to locate the position of the end rivets so they will have the proper edge distance from both the end and the sides of the sheet. Mark these locations with a center punch to enable starting a twist drill in the correct position. Then, with a pair of dividers, separate the distance between the two end rivets into five equal spaces to find the location of the six rivets for the first row. These rivets will be 5/8 inch apart, or five diameters, which is well

within the allowable spacing of between 3 and 12 times the rivet shank diameter (3D to 12D).

The gauge, or distance, between the rows should be about 75% of the pitch and, in this case, will be 0.468 inch. For practical purposes, 1/2 inch (.5) is adequate. Mark a row across the strap 1/2 inch from the first row of rivets and locate the five holes needed on this line. These holes should be centered between the rivets in the first row. Again, mark the rivet locations with a center punch. [Figure 2-98]

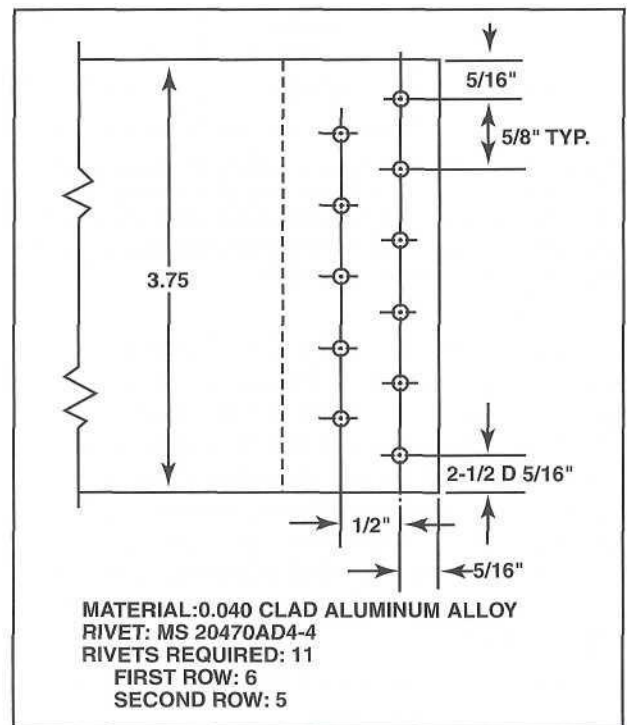

Figure 2-98. When multiple rows of rivets are used in a layout, the transverse pitch should be approximately 75% of the rivet pitch, and the rivets should be staggered.

HOLE PREPARATION FOR RIVETS

The hole in which a rivet is installed is critical to the strength of the finished repair. The hole must be slightly larger, but not so large that the expanded rivet does not fill the hole. Sizes of holes for all conventional rivets can be found in charts included in most aircraft technician handbooks. It is important that the hole be properly drilled and finished prior to a rivet being driven.

DRILL SIZE

The twist drills used for aircraft sheet metal work are most generally of the number and letter sizes, rather than the fractional sizes commonly used in other forms of mechanical work. Most of the rivets used in sheet metal work are between 3-3/32 inch,

which is the smallest rivet generally allowed in aircraft structure, and 3/8 inch diameter. Rather than using rivets larger than 3/8 inch, some other form of fastener is normally used. [Figure 2-99]

RIVET DIAMETER	PILOT SIZE	FINAL SIZE
3/32	3/32 (.0937)	40 (.098)
1/8	1/8 (.125)	30 (.1285)
5/32	5/32 (.1562)	21 (.159)
3/16	3/16 (.1875)	11 (.191)
1/4	1/4 (.250)	F (.257)
5/16	5/16 (.3125)	O (.316)
3/8	3/8 (.375)	V (.377)

Figure 2-99. The final hole for a particular rivet size can be prepared by drilling a hole the size of the rivet and then reaming the hole to the final dimension. Where less critical applications are allowed, the final dimensions can be drilled using a number or letter twist drill.

The number drill size for each diameter rivet is slightly larger than the rivet diameter. As previously mentioned, the holes made by these drills are usually three- or four-thousandths of an inch larger than the diameter of the rivet. This allows the rivet to be slipped in place without forcing it and scraping any protective oxide coating off the rivet shank. The clearance is small enough that, during driving, the shank will swell to take up any excess clearance. [Figure 2-100]

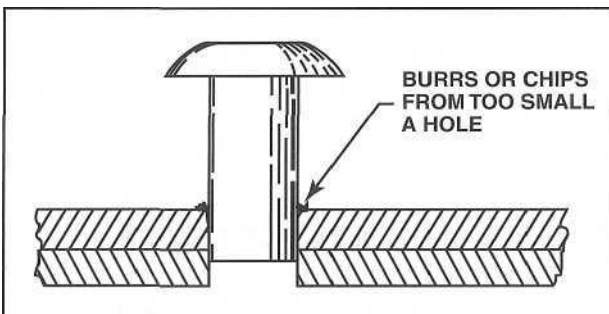

Figure 2-100. Too small a hole will destroy the protective oxide coating on a rivet shank and may also cause the sheet metal to buckle once the rivet is driven.

RIVET HOLE PREPARATION

Since rivet holes drilled in sheet metal are usually small and the metal is soft, lightweight drill motors can be used to produce rivet holes. For safety, most sheet metal drilling is accomplished using pneumatic drills, so the chances of electric shock and arcing are reduced. In addition, pneumatic drill motors are usually equipped with triggers that permit controlling the motor speed by varying the

amount the trigger is depressed. This is very handy as it allows the hole to be started with a slow speed, which provides better drill control. As the hole begins to form, a faster speed can then be used to permit production that is more efficient.

When selecting a twist drill for rivet hole preparation, examine the point to be sure that it is properly ground and sharp. To prevent the twist drill from wobbling during drilling, the point of the tip should be in the exact center of the drill. To help ensure uniform tension on the shank of the twist drill, it is recommended that the chuck of the drill motor be tightened using each of the chuck key holes with the proper size chuck key.

Proper drill motor use is an important consideration for preparing acceptable rivet holes as well as for safety. When using a drill motor, hold the tool in a manner similar to that shown in Figure 2-101. This allows for maximum tool control and aids in preventing the drill from pushing through the metal so far as to possibly cause damage to structures behind the drilled surface.

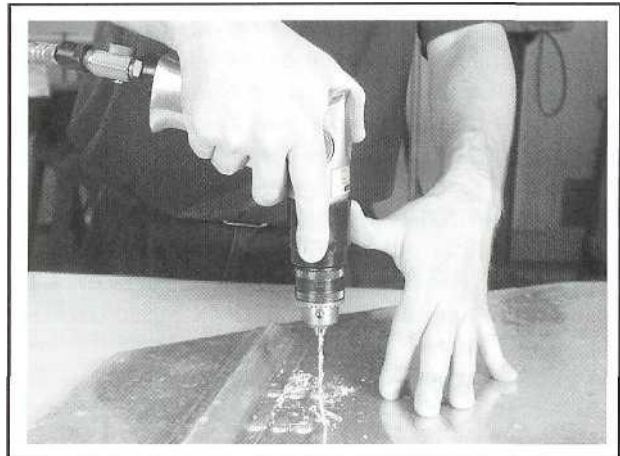

Figure 2-101. When using a drill motor, hold the drill as shown in this figure. Pointing the index finger parallel to the drill chuck will aid in aligning the twist drill with a 90 degree angle to the drilled surface.

To prevent injuries and damage to aircraft structures when using a drill motor, observe the following safety considerations:

1. Be sure there are no burrs on the twist drill shank that could prevent it from fitting properly in the chuck.
2. When changing twist drills, it is advisable to disconnect the air source before tightening the chuck with a chuck key. If the air source is left connected, injuries may occur if the trigger is inadvertently activated. Also, never attempt to

tighten a drill chuck by holding the chuck stationary by hand and operating the drill motor.

Before drilling a hole, run the drill motor and watch the end of the drill. It should not appear to wobble. If it does, remove it from the chuck and check to see if it is bent, by rolling the twist drill over a flat surface. Also, check the twist drill shank for burrs that would prevent it from centering in the chuck. Bent drills and worn chucks will cause oversize holes that can ruin a repair.

Be sure to wear eye protection when drilling. Fine chips of metal are propelled from the rapidly spinning twist drill and by the air exhaust from pneumatic drill motors. [Figure 2-102]

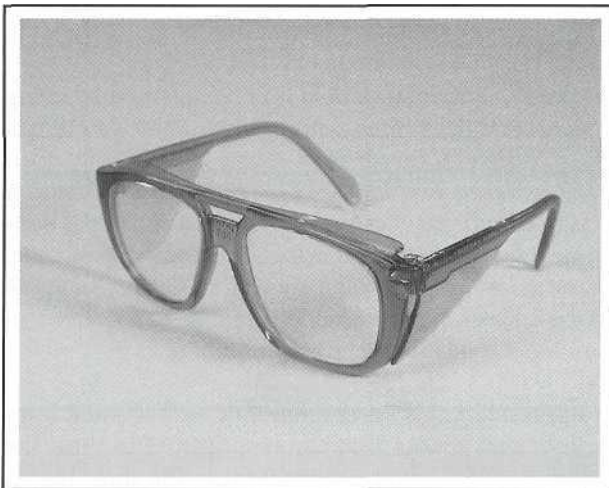

Figure 2-102. Be sure to wear adequate eye protection when drilling sheet metal. Impact resistant safety glasses with side shields should be worn at all times while working around sheet metal fabrication areas in the shop or on an aircraft.

When the drill and drill motor are ready, prepare the metal. Mark the location for drilled holes with a center punch and make the indentation just large enough for the twist drill to start cutting. Too small a mark will allow the drill to walk, while too heavy a blow with the center punch may distort the metal. Also, to prevent distorting the metal, it is advisable to use a scrap piece of wood to backup the material to oppose the force of the drill motor.

For right handed individuals, hold the handle and the trigger with the right hand while using the left hand to rest on the work. Push back against the drill motor with the left hand to provide a balance to the pressure applied in the drilling operation. Center the point of the drill in the center punch mark and start the drill motor slowly until the twist drill

begins to cut the metal with the full face of the tip. Once the tip makes full contact, increase the speed of the drill to a faster speed, but not so fast as to cause loss of control. Use enough force to keep the drill cutting smoothly, but as soon as the tip begins emerging through the metal, relax the pressure on the drill motor. Allow the tip and a portion of the twist drill body to go through the metal, but do not allow the chuck to touch the work. If the chuck contacts the surface, it will cause scratches, damaging the finish of the metal. This is especially critical if the metal is clad with a protective finish.

When two or more sheets of metal are being drilled together, once the first hole is drilled, use a Cleco or similar temporary fastener to secure the metal together. Failure to use a temporary fastener may cause the metal to slip during subsequent drilling, causing misalignment of holes when the drilling is complete.

DEBURRING

When aluminum alloys are drilled sharp burrs can remain on the edge of the hole. If these burrs are not removed before riveting, the sheets of metal will not fit tightly together. This not only causes cosmetic flaws, but also prevents the rivets from providing maximum shear strength. In addition, when sheet metal is cut, burrs can also form along the edges of the metal. To remove these sharp edges and burrs, a process referred to as deburring is accomplished.

Deburring consists of using tools to remove excess material from around the edges of the sheet metal. As previously discussed, examples of tools that can be used for hole deburring include fabricating a handle made from wood and installing a twist drill or countersink cutter that is larger than the drilled hole. Lightly turning the twist drill or cutter in a hole tends to remove the excess material from around the edges. However, when using these tools, make certain to apply only a light pressure to avoid countersinking the hole. Deburring should remove only the material that is above the surface of the sheet metal.

Specialty tools are also available and may be used to increase the speed and accuracy of deburring. For hole deburring, a tool is available that has a cutter that can be rotated by a handle, wherein the handle is swiveled to cause the cutter to rapidly remove sharp edges and burrs without countersinking. For edge deburring of sheet metal, tools are available that have a notch cut in them so the tool can be pulled across the edge to deburr both sides of the metal in a single operation. Make certain all holes

and edges are deburred before installing any rivets. When two or more sheets have been drilled together, separate the sheets and deburr the holes on each side of the metal. [Figure 2-103]

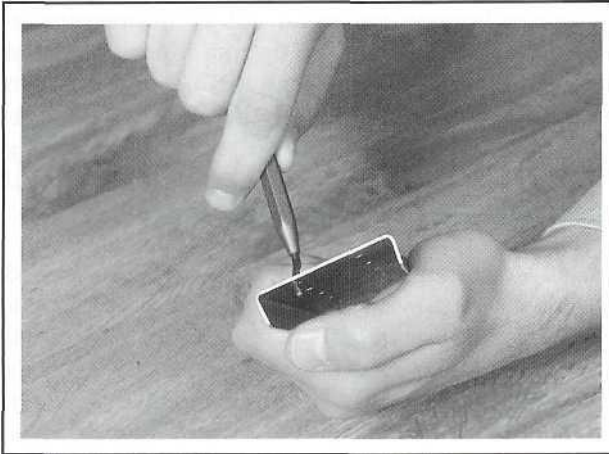

Figure 2-103. Specialty deburring tools are available commercially and come in a variety of styles and sizes.

HOLE PREPARATION FOR FLUSH RIVETS

It is extremely important that the skin on high-speed aircraft be as smooth as possible. On many of these aircraft, airfoils are assembled using flush head rivets to increase the laminar flow of air over the surface of the skin. In order for the rivets to seat as flush as possible, the skin must be contoured or machined to accept the head of the rivet to a depth that places the rivet head flush with the surface. To produce a countersunk hole, a number of processes may be used. In some situations, the surface material is machined away by a countersink cutter while in others the rivet head is pressed or dimpled into the skin. In either case, modern countersinking for rivets involves forming a recess with a 100 degree taper. [Figure 2-104]

COUNTERSINKING

When the top sheet of metal being joined is thicker than the tapered portion of the rivet head, the sheet

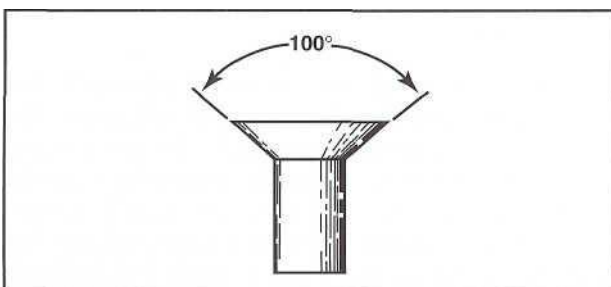

Figure 2-104. Flush rivets used on modern aircraft include the AN426 or MS20426 rivet. These rivets have a head angle of 100 degrees and are measured as shown here.

can be countersunk to produce a smooth riveted surface. If the sheet is too thin, the rivet head will protrude past the surface of the metal and cause the shearing zone of the joint to be applied to the rivet head rather than across the shank. This not only reduces the effectiveness of the rivet, but also weakens the skin by removing too much material. [Figure 2-105]

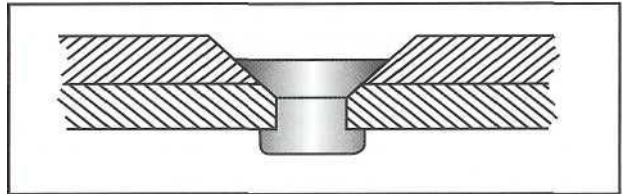

Figure 2-105. The depth of the rivet head limits countersinking a recess in sheet metal. If the metal is too thin, the countersink will enlarge the hole and cause the metal to shear across the head instead of the shank.

Milling a countersunk hole is accomplished by using a countersink or micro-stop cutter after a hole has been drilled to the desired shank diameter. A standard countersink for aircraft rivets has a cutting angle, which matches the 100 degrees of the countersunk rivet head. A standard countersink can be used in a drill motor, but the difficulty in cutting the hole to the correct depth makes this tool impractical when you have multiple holes to countersink.

A **micro-stop**, or **stop countersink**, as it is sometimes called, uses a cage that can be adjusted to limit the depth that the cutter penetrates into the sheet metal. With this tool, the depth of the cutter is adjusted in increments of .001 inch to obtain a uniform countersunk depth in multiple holes. Sample countersinking tools are shown in Figure 2-106.



Figure 2-106. Countersink cutters and the cutters used in micro-stops are manufactured with a 100 degree cutting angle. With some cutters, a pilot is milled onto the end while others have interchangeable pilots. Pilots are available in various sizes to match the diameter of the rivet shank and help position the cutter in the center of the hole.

A micro-stop countersink is used far more often than a standard countersink cutter. When using a micro-stop, the cage portion of the tool is held stationary against the metal, and the countersink is pushed into the hole until the cutter reaches a stop, limiting the depth of the countersink. With a micro-stop, a shaft fits into the chuck of a 1/4 inch air or electric drill motor, and the cutter screws onto this shaft.

When adjusting the stop, set the countersink depth to cut the proper amount by using a piece of scrap metal the thickness of the top sheet being riveted. Drill some holes the size used for the rivet, and adjust the stop by screwing the cage up or down on the body and locking it into position with the lock-nut. Hold the stop with one hand and position the cage collar tightly against the sheet metal. Then, press the trigger on the drill motor and push the cutter into the metal until the stop is reached. Once milled, slip the countersunk rivet into the hole and check the flushness of the head across the surface of the sheet. Depending on the operation, the rivet may be raised a few thousandths of an inch above the surface, to be milled smooth with a microshaver.

A microshaver is a pneumatic tool that turns a flat-faced milling cutter at high speed. The tool is equipped with a stop that is adjustable to limit the amount the cutter extends out from a guard. By regulating the depth of the cutter, the rivet head can be milled perfectly flush with the metal. [Figure 2-107]

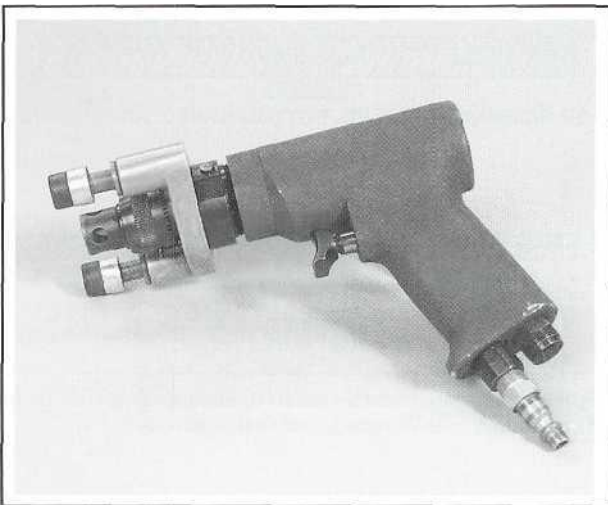

Figure 2-107. A microshaver is a high-speed milling tool that is useful in shaving the heads of rivets, to obtain an accurate flush fit to the surface of the sheet metal.

DIMPLING

When the top sheet of metal is too thin to countersink, the edges of the hole may be formed to accommodate the head of the rivet by using a set of dim-

pling dies. There are two methods of dimpling sheet metal: coin dimpling, which forges, or coins, the metal into the dies, and radius dimpling, which folds the material down to form the dimple. Although both techniques are commonly used, coin dimpling generally provides a slightly tighter fit but tends to leave a sharper bend around the rivet head. Radius dimpling may not produce as tight a fit, but has the advantage of leaving a more gradual radius bend around the rivet head, helping to prevent cracking during service.

Coin Dimpling

In coin dimpling, a male die fits through the rivet hole, and a coining ram in a female die exerts pressure on the underside of the hole. By forcing the male die into the female die, the metal contours to the shape of the coin. The pressure on the dies forges the edges of the hole to exactly fit the shape of the dies. Coin dimpling gives the hole sharply defined edges that almost resemble machine countersinking. Both the top and the bottom of the dimple are formed to a 100 degree angle, so multiple sheets can be dimpled and stacked, or nested. [Figure 2-108]

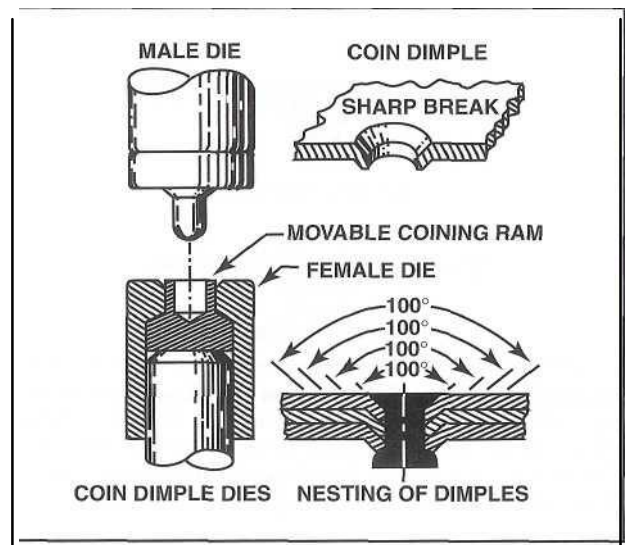

Figure 2-108. Coin dimpling is performed by a special pneumatic machine or press, which has, in addition to the usual dies, a "coining ram." The ram applies an opposing pressure to the edges of the hole so the metal is made to flow into all the sharp contours of the die, giving the dimple greater accuracy and improving the fit.

Radius Dimpling

Radius dimpling is a form of cold dimpling in thin sheet metal in which a cone-shaped male die is forced into the recess of a female die, with either a hammer blow or a pneumatic rivet gun. In some instances, a flush rivet is used as the male die. The

male die is forced into the female die. In this form of dimpling, a rivet gun is fitted with a special female dimpling die, and the rivet head is set into the sheet metal by rapid impact blows of the rivet gun. The dimple formed in this way does not have parallel sides, as the lower side has an angle greater than 100 degrees. For this reason, radius dimpling is not usually considered acceptable to stack or nest multiple sheets. [Figure 2-109]

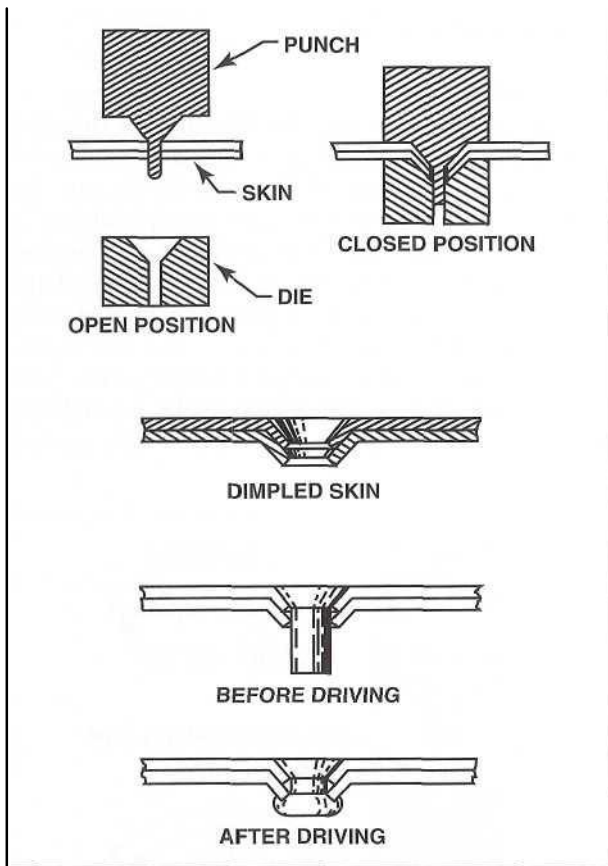

Figure 2-109. Radius dimpling does not allow the sheets to be nested unless the bottom sheet is radius dimpled. Radius dimpling is done because its equipment is smaller than that needed for coin dimpling, and can be used in locations where access with coin dimpling tools is not practical.

Hot Dimpling

Magnesium and some of the harder aluminum alloys, such as 7075, cannot be successfully cold dimpled, because the material is so brittle it will crack when the dimple is formed. To prevent cracking, these materials are heated before dimpling is accomplished. The equipment for hot dimpling is similar to that used for coin dimpling, except that an electrical current heats the dies.

To perform hot dimpling, the dies are preheated and then the metal is positioned between the dies. When

the technician presses a pedal, the dies are pneumatically pressed together until they both just make contact with the metal. Once the dies make contact, a dwell time allows sufficient heat to soften the metal before the dies are fully squeezed together to form the dimple. The dwell time for heating is automatically controlled by a timer to prevent destroying the temper condition of the metal. The operator of the machine must be familiar with how to adjust the machine for the various time limits and temperatures for the types of metal being formed.

MULTIPLE SHEET FLUSH RIVETING

The proper preparation of holes for flush riveting depends upon the thickness of the sheets being joined. If the top sheet is thick enough to be countersunk, the substructure, or lower skins, need nothing more than to have the holes drilled for the rivet. But if the top skin is too thin to be countersunk, it must be dimpled and the bottom skin either countersunk or dimpled. In this situation, the top skin must be coin dimpled so the bottom of the dimple will fit into the 100 degree inside angle of the dimple or countersink in the lower skin. [Figure 2-110]

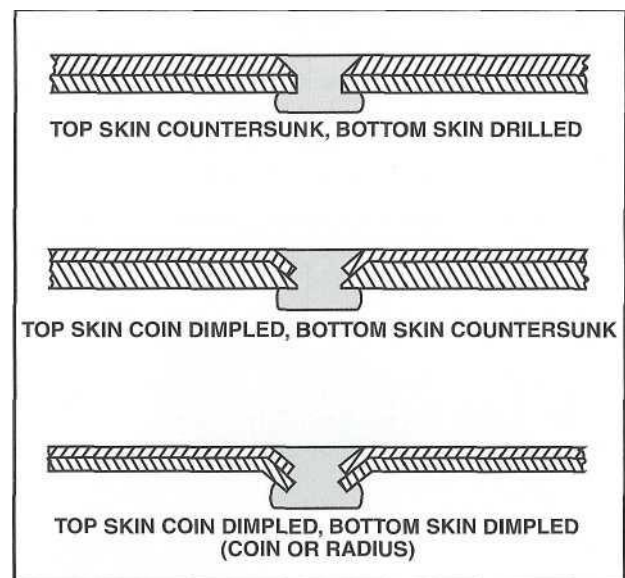

Figure 2-110. Care must be taken to ensure compatibility of countersunk, coin dimpled, and radius dimpled skins.

RIVET INSTALLATION

Because of the many thousands of rivets used to hold an aircraft structure together, it is easy to get complacent with the riveting process and not be concerned about less than perfect riveting techniques. However, each rivet must carry its share of the total load in an aircraft structure. If a rivet is not properly installed, it can force the adjacent rivets to

carry more load than they are designed to take, ultimately causing a structure to fail.

In addition to the proper preparation of a hole for a rivet, the strength of a riveted joint is determined by the way the rivets are driven. When installing rivets, it is important to install the rivet with as few impacts as possible so the materials will not work-harden and crack. The shop head of the rivet should be concentric with the shank and flush with the surface without tipping. In addition, the formed, or bucked head, should be fabricated to proper dimensions.

HAND RIVETING

Almost all rivets are driven with either a rivet gun or squeeze riveter, but there are times when building small components, or when working in areas without air or electricity, that it is necessary to drive a rivet by hand. The process used for hand driving aircraft rivets is not the same as that used by some other commercial sheet metal processes. Aircraft rivets driven in flat sheets are never peened over. Instead, the shank is collapsed with a hand set in much the same manner as other aircraft riveting techniques.

To drive a rivet by hand, the material to be joined is prepared by drilling and deburring a hole, and a rivet is inserted to extend one and a half shank diameters through the metal. A special metal bar that has a recessed contour approximately the shape of the rivet head is then mounted in a vise with the recess facing upward. The rivet is placed through the hole in the metal and the rivet head is put in the recess of the metal bar. A draw set is slipped over the rivet shank and tapped lightly with a hammer to draw the sheets of metal tightly together. A hand-set is then placed on top of the rivet shank and struck with a hammer to force the rivet to compress to the proper dimensions. It is important to strike the set hard enough that the rivet compresses with only three or four strikes of the hammer to prevent work-hardening the rivet. Be sure to use the hand-set rather than striking the rivet directly with the hammer, as the hand-set is machined to provide a smooth surface to the formed head. [Figure 2-111]

COMPRESSION RIVETING

When there are a large number of easily accessible rivets to be installed, a compression, or squeeze riveter, can be used instead of hand or gun riveting. These riveting tools reduce the time required to install the rivets and produce a far more uniform shape than can be driven by hand or with a rivet gun.

A squeeze riveter consists of a pair of jaws; one stationary and the other moved by a piston in an air

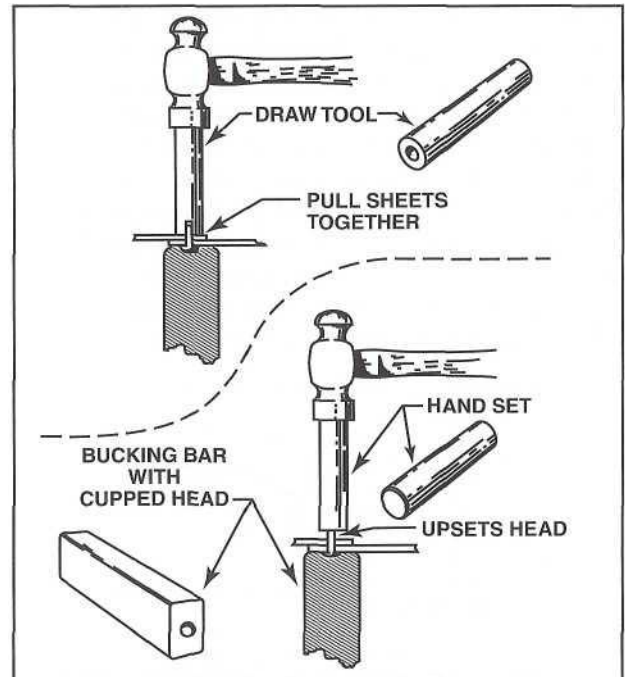

Figure 2-111. Hand riveting is performed where it is inconvenient to use conventional riveting equipment. However, the standards for acceptable hand driven rivets are the same as for all other riveting methods.

cylinder. A dolly, milled with a recess similar to the shape of the rivet head, is put into the stationary jaw, and a flat dolly is placed in the movable jaw. When a handle or trigger is depressed, air flows into the cylinder and squeezes the jaws together to compress the shank of the rivet in a uniform motion. [Figure 2-112]

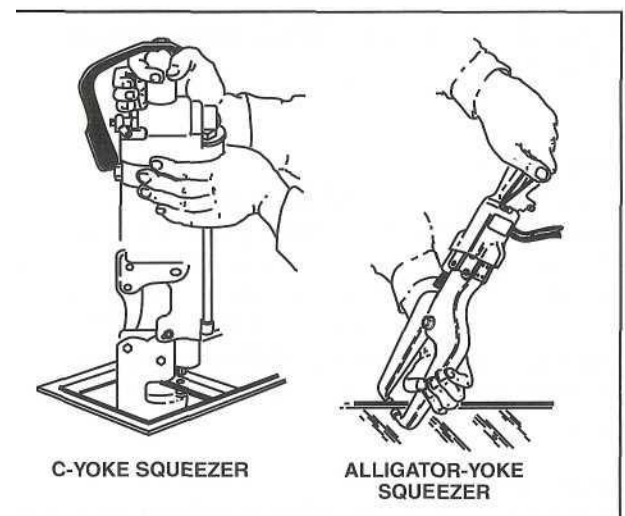

Figure 2-112. Squeeze riveter jaws or yokes are available in different lengths and configurations. Although these tools are extremely useful, the yoke length limits the use of the squeeze riveter to rivets that are located reasonably close to the edges of sheet metal structures. For this reason, these tools are used primarily in production rather than repair processes.

Shims placed between the jaws and the dollies control the separation of the dollies at the end of the piston stroke, and this determines the height of the shop head formed on the rivet. The number of shims needed is determined by trial and error, using scrap material of the same thickness as that to be riveted. Once the dollies are adjusted, all of the compressed rivets will have exactly the same height and diameter. In addition, the smooth compressive pressure used to upset the rivet will have a minimum strain-hardening effect on the rivet shank. [Figure 2-113]

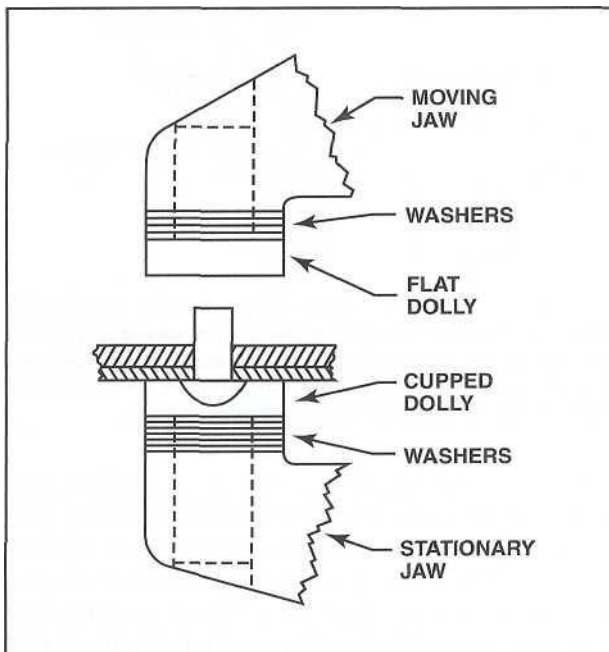

Figure 2-113. To adjust the height of the shop head formed by a squeeze riveter, add or remove washers between the dollies and the jaws.

GUN RIVETING

Hand riveting and compression riveting are used for special conditions, but a rivet gun drives most rivets used in aircraft construction. These tools look and operate in a similar fashion to a reciprocating air hammer, but the number of strokes and force of the impact are considerably different. As such, only guns designed for riveting should be used on aircraft structures.

Rivet Gun Types

There are a number of different types of rivet guns used for aircraft fabrication and repair, but these can be divided into two basic categories: fast-hitting, short-stroke guns, which produce light blows, and guns with long strokes that produce heavy blows. The fast-hitting guns are usually used for 3/32 inch or 1/8 inch rivets. These guns have bodies made

from aluminum alloy castings so they are light enough that the user will not be fatigued after using the gun for a prolonged period. The long-stroke gun may be either a slow-hitting reciprocating type, or a one-shot gun that drives the rivet set only one blow each time the trigger is pulled. These guns are used to drive the larger rivets and are much heavier than fast-hitting guns.

Handle styles also vary with different types of guns. The pistol grip and offset handle are the most popular styles, with a push-button type available for special applications where neither of the other styles of guns will fit because of clearance problems. [Figure 2-114]

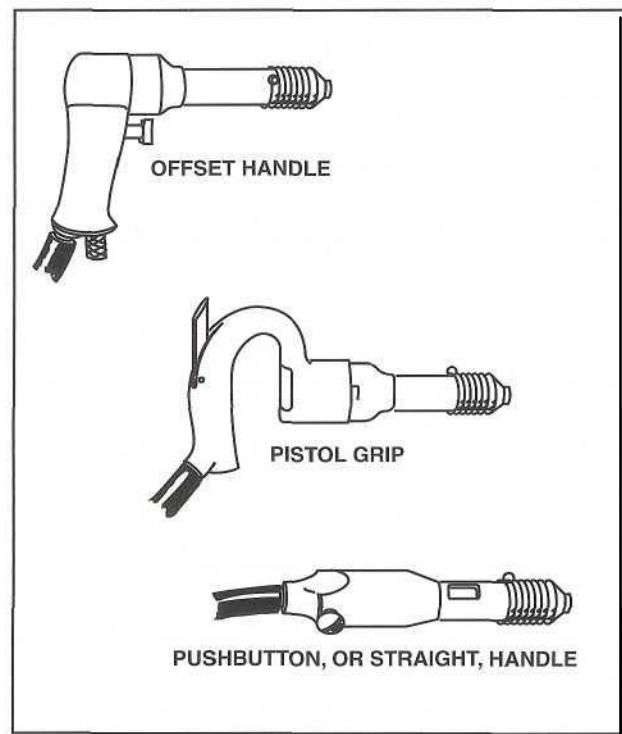

Figure 2-114. Different handle styles are available on rivet guns to fit various locations and operator preferences.

When the trigger, or throttle, as it is sometimes called, is pulled, air enters a sliding valve and drives a piston forward against the stem of a rivet set. When the piston reaches the end of its stroke, a port is uncovered by the valve that directs air to the forward end of the piston, and moves it back so it can get air for another driving stroke. As long as the trigger is held down, the gun will reciprocate, or hammer, on the rivet set. A regulator, built into the handle of the gun or attached to the air hose, restricts the flow of air into the gun. If the regulator is wide

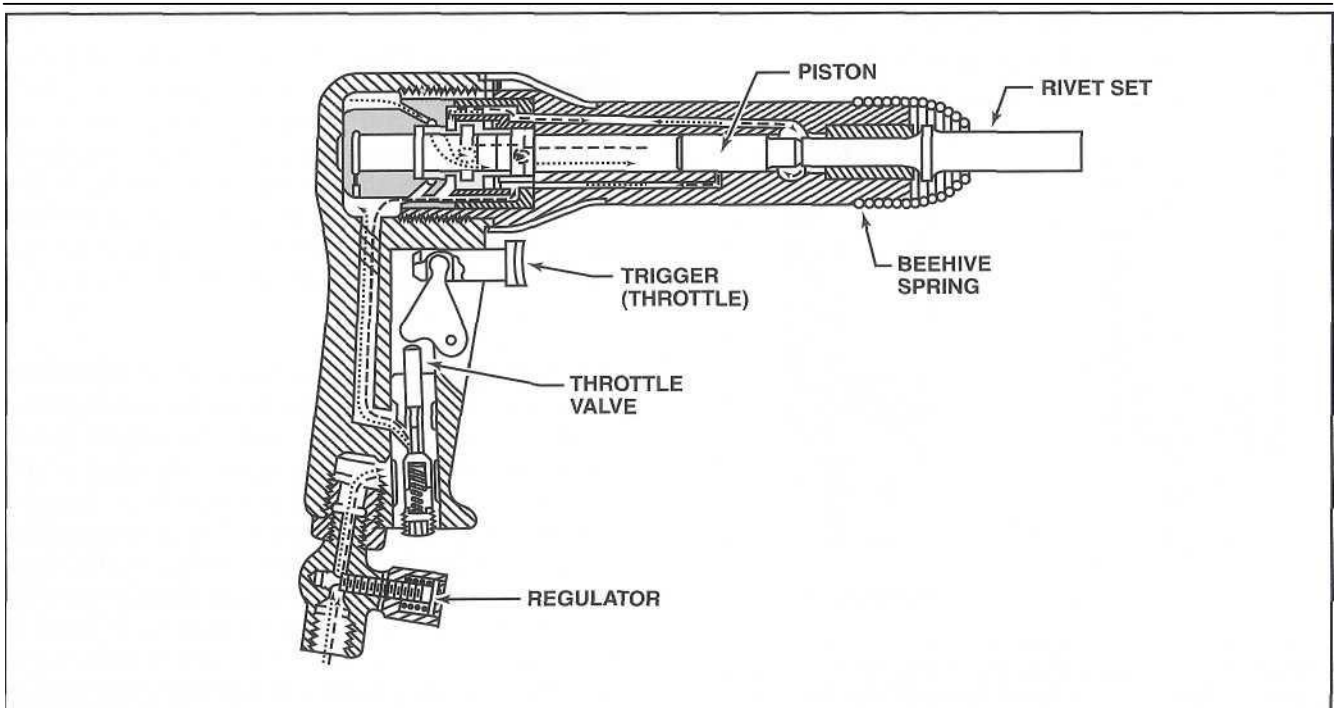

Figure 2-115. An air regulator, in combination with the gun trigger, allows the operator to vary the impact speed and intensity for various sizes and alloy rivets.

open, the gun will hit hard and fast, or the regulator can be adjusted to restrict the air flow to cause the gun to hit slower and softer. [Figure 2-115]

The gun has a provision whereby different sets can be installed for different sizes and head styles of rivets. If the gun is operated without a set being installed, the piston can be severely damaged if the trigger is pulled, or if the set is not pressed tightly against either a rivet or piece of scrap wood. The rivet set is held in place by a retaining spring, sometimes called a beehive because of its appearance. Without the retaining spring, the set can fly out from the gun if the trigger is pulled without the set being against an object. As a safety precaution, the gun should never be pointed at a person and the trigger pulled, even with a retaining spring installed. If the spring were to break, the set could fly out and cause injury to the person.

Rivet Sets

Rivet sets are manufactured differently for various head styles and sizes of rivets. In the past, the numerous styles of raised-head rivets required a set that was designed for each of the styles, causing a technician to acquire a large assortment of sets. Fortunately, with newer sheet metal fabrications, universal head rivets can be used to replace almost any protruding head rivet. This means that a tech-

nician rarely needs more rivet sets than those that fit the various sizes of universal head rivets. Flush head rivets also require a special set, but generally, any flush head rivet can be driven with a flush head set.

It is important when selecting a universal rivet set for a particular job that its size and shape be correct for the type rivet being driven. When selecting rivet sets, the radius of the depression in the set must be larger than that of the rivet, but not so large that the set contacts the sheet metal during driving. In addition, damage on the recess face of the set may cause it to slip off the rivet during driving, or the set may leave unacceptable marks on the rivet head.

The recess in a universal style rivet set is machined with a slightly larger radius than the rivet head. By having a greater radius, the set concentrates more of the rivet gun's driving energy to the center of the rivet head. However, if the set is too large, it will produce small indentations in the sheet metal around the rivet head. These indentations are commonly referred to as smiles because of the shape they leave in the metal. In most cases, these indentations are unacceptable because they damage the protective coatings of the metal, or create stress concentration points that can cause the metal to fail around the rivet. On the other hand, if the set is too small, it will

produce a similar type mark on the rivet head, which is also unacceptable. [Figure 2-116]

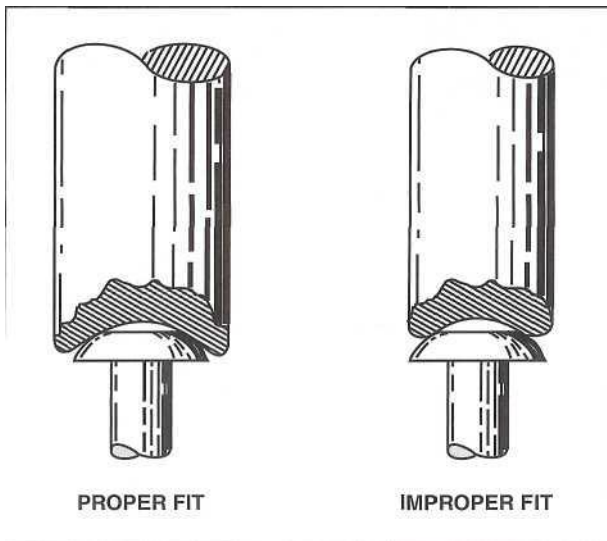

Figure 2-116. The radius of the cup of the rivet set must be slightly larger than the radius of the rivet head, but not so large that the edges of the set contact the surface of the metal.

Not only must the rivet set have the correct size and shape of depression, but it must also fit squarely on the rivet head. Because the structure inside an aircraft sometimes makes it difficult to align the gun exactly with the rivet, rivet sets are made in many lengths and shapes. Some sets are manufactured with a straight shank while others have one or even two offsets. When selecting a rivet set, make certain that its shape concentrates the blows of the rivet gun as close to in-line with the rivet as possible. [Figure 2-117]

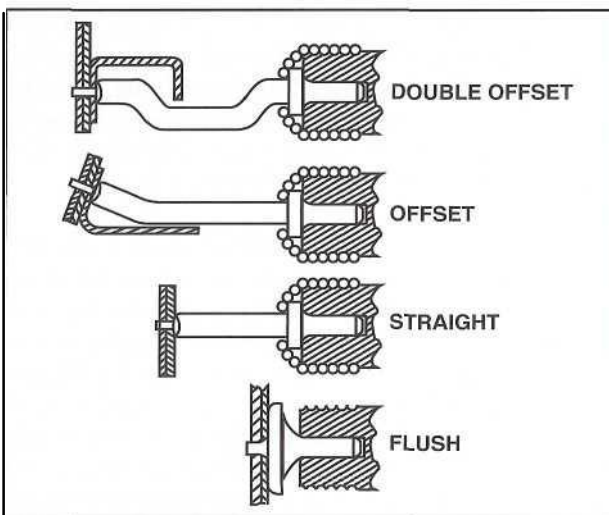

Figure 2-117. Rivet sets are available with different offsets to allow the blows from the gun to be directed straight in-line with the rivet. These sets are useful in locations where structures interfere with a straight shank set.

Bucking Bars

When a rivet is driven, the actual compression of the rivet is not performed by the action of the rivet gun. Instead, the rivet is backed up by a metal bar that reciprocates in response to the beats of the rivet gun. This reciprocating action causes the rivet to be compressed in successive actions. These metal bars are referred to as bucking bars because of the method in which the bar bucks, or vibrates, on the shank of the rivet.

The driving face of a bucking bar is machined smooth and polished so that no marks are left on the rivet shank during driving. This hardened and polished steel surface is held against the end of the rivet shank, and pressure is applied as the gun vibrates the rivet against the bar. The position of the bucking bar is critical in the formation of the shop, or bucked head. If the bar is tipped slightly, the rivet will dump over and not form a concentric head. If too much pressure is held on the bar, or if the bar is too large, the shop head will be driven too thin, or the manufactured head may be forced up from the surface of the metal. On the other hand, if the bar is too small or is not held tight enough, the hammering of the rivet gun may distort the skin.

There are many sizes and shapes of bucking bars used in aircraft maintenance. One of the challenging tasks of performing structural fabrications by riveting is being able to select a bucking bar that will clear the structure and fit squarely on the end of the rivet shank. In the same fashion as a rivet set, when a bucking bar is selected, its mass should be as close to being in-line with the rivet as possible. In addition, the weight of the bar should be heavy enough to allow driving the rivet in a few short beats of the rivet gun, yet not so heavy that the operator has difficulty holding the bar in the correct position. Before using any bucking bar, inspect the face of the bar to make certain no damage is present that will leave an indentation on the formed head of the rivet. [Figure 2-118]

Rivet Gun Set-Up and Adjustment

One of the most difficult tasks for an aircraft technician to learn is how to properly and efficiently install rivets using a rivet gun. The skills necessary to perform gun riveting are acquired over time and must be practiced on a regular basis in order to remain proficient. One task that must be learned before trying to install rivets is setting up and adjusting a rivet gun for a particular operation. Since improper riveting can cause irreparable damage to an aircraft structure, experience should first be gained by developing riveting techniques on practice projects.

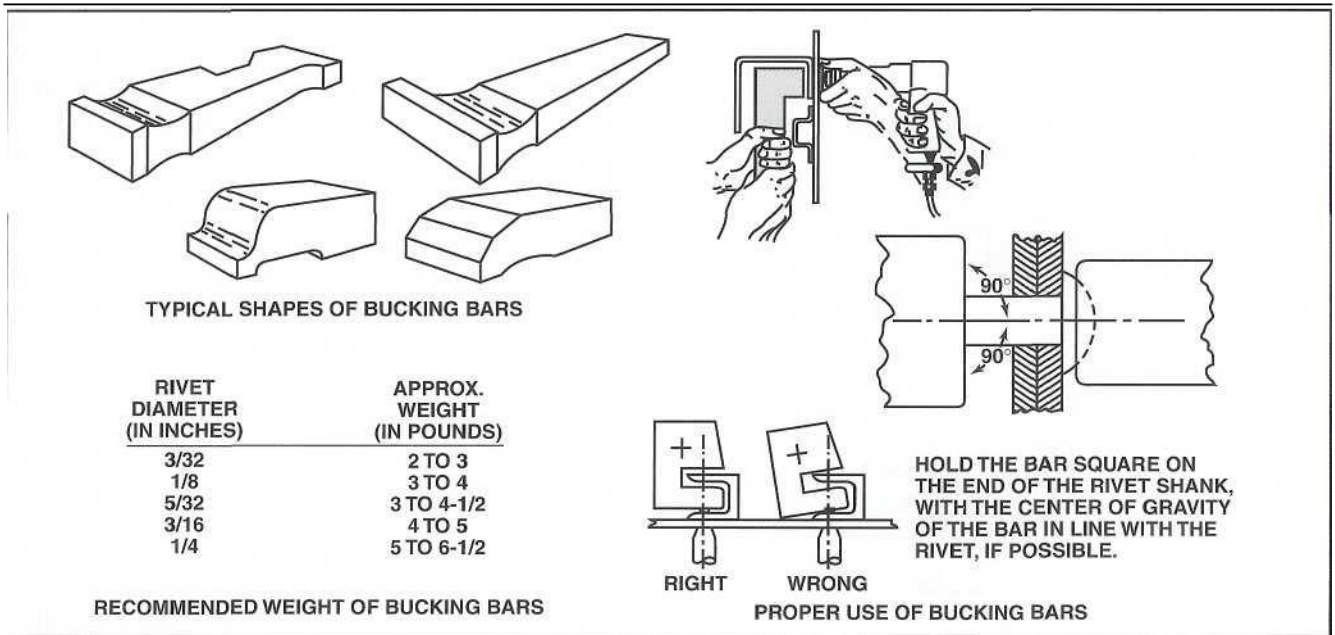

Figure 2-118. Bucking bars are available in different weights and shapes to allow riveting of solid rivets in almost any location.

Begin a practice project by trimming two sheets of aluminum to a manageable dimension. Sheets trimmed to six inches square are often used because of the ease in clamping the material in a vise. Align the edges of the material and drill a number of holes for the correct diameter rivet, deburr the edges, and clamp the material in a padded-jaw vise.

Select a rivet set that is appropriate for the head style and size rivet to be installed and insert it in the rivet gun. Once the set is in place, install a retaining spring to keep the set from being propelled out of the gun during operation. Once the set has been installed, connect an air hose to the gun and place the set against a soft piece of wood to perform an initial adjustment of the air regulator.

With the set in place against the wood, depress the trigger to cause the gun to pound against the wood. If the gun is set properly, the wood will be left with an indentation approximately the depth of the recess in the set, with only a few gun raps. If the gun strikes the wood too hard, adjust the air regulator for a lower pressure, or limit the amount that the trigger is depressed. This is usually a good starting adjustment, but will probably have to be adjusted further when driving a rivet. [Figure 2-119]

Rivet Installation

Once the metal has been drilled, put a rivet of the correct length through a hole and hold the rivet gun

set against the manufactured head of the rivet. The set must be directly in line with the rivet, and not

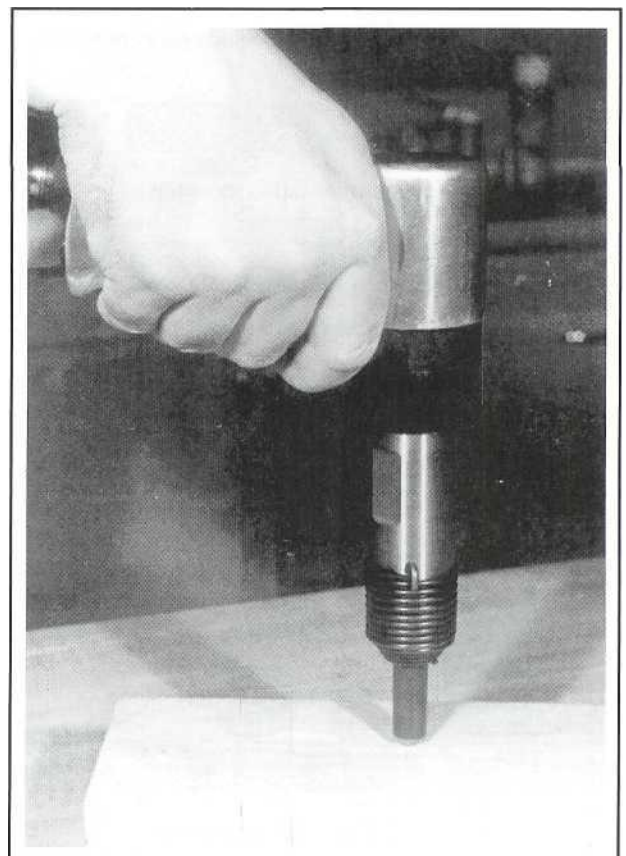

Figure 2-119. Adjust the airflow to the gun so it will indent a scrap of wood but will not shatter it.

tipped or it will contact the sheet metal during driving. [Figure 2-120]



Figure 2-120. Hold the rivet set square with the rivet head and support the gun so the set will not slip off during driving.

Hold a bucking bar flat against the end of the rivet shank and develop a good feel of the balance between the gun and the bucking bar. A proper balance is obtained by applying just enough extra force on the gun to hold the rivet head firmly against the skin. Once the gun is in position, pull the trigger to provide a short burst of raps on the rivet head. The rivet should be driven with the fewest blows possible so it will not work-harden the rivet, which can cause cracks to form. It may be necessary to further adjust the rivet gun airflow to fine-tune it for the installation of subsequent rivets.

Evaluating Driven Rivets

In the process of developing riveting skills, it is inevitable that some rivets will be driven improperly. One of the requirements of a technician is to be able to quickly identify rivets with unacceptable characteristics. In addition, the technician must be able to remove damaged or improperly installed rivets without adversely affecting the base sheet metal, and then be able to correct the problem with the installation of replacement rivets. [Figure 2-121]

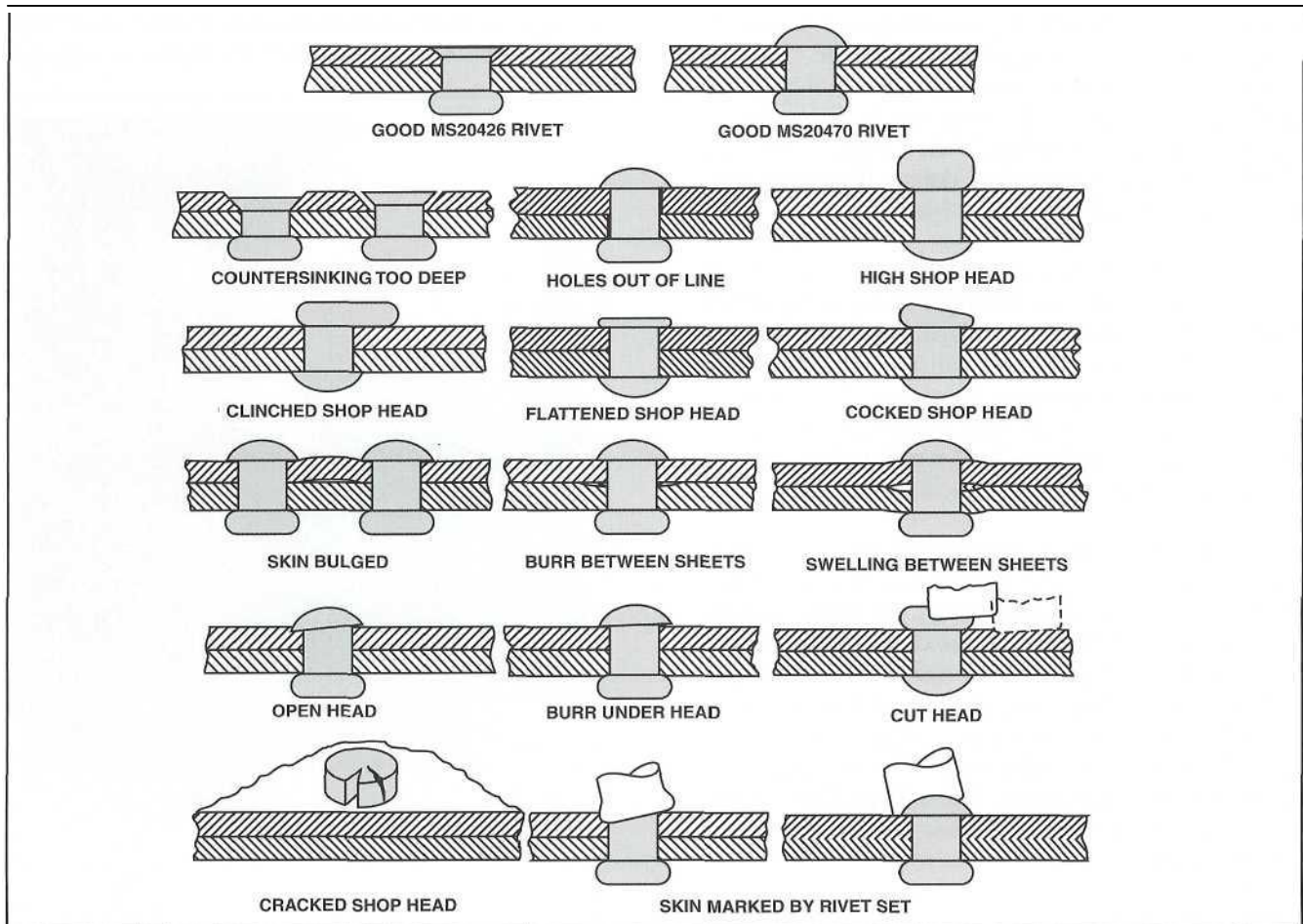

Figure 2-121. A technician must be able to identify properly driven rivets. Until the technician has gained enough experience to evaluate driven head dimensions, special gauges may be fabricated to check shop head shapes and sizes.

As previously mentioned, a properly formed shop head will be one-half the shank diameter in height with a diameter that is one and a half times that of the shank diameter. In addition, the rivet should be uniform with adjacent rivets and each rivet should be driven concentric with the hole. Placing a straightedge on top of shop heads that have been driven in a row can check the uniformity of rivet heights. Each surface of the shop heads should touch the straightedge without gaps.

The rivet shank should also be checked for concentricity. Concentricity is achieved when the shop head of the rivet compresses in an even fashion around the shank. It is detected by looking closely for a circular mark left on the driven head. A rivet that has been properly driven will have an even margin between the circular pattern and the edge of the shop head. If the margin is uneven, it usually indicates the bucking bar slipped across the rivet during driving, causing the shop head to form an oval shape or to be off center with the shank of the rivet.

The manufactured head of the rivet must also be perfectly flat against the metal. If a thin feeler gauge

blade can be slipped between the manufactured head and the skin, the rivet must be removed and the cause of the improper fit determined. The rivet may be tipped in the hole by a small burr, or the hole may have been drilled at an angle. If the hole was improperly drilled, the only satisfactory repair is to re-drill the metal to accept the next larger diameter rivet.

Rivet Removal

When it has been determined that a rivet has been improperly installed, the rivet must be removed and replaced without damaging the base metal. To remove a rivet, lightly indent the center of the manufactured head with a center punch. Be sure to back-up the shop head with a bucking bar when center punching so as not to distort the skin. Use a drill the same diameter as the hole or one that is one number size smaller to drill down to the base of the rivet head. Once drilled, use a pin punch with a diameter the same size as the rivet shank diameter to pry the head off, or tap the head lightly with a cape chisel to break it off from the shank. If a chisel is used, be sure that it does not scratch the skin around the rivet head. [Figure 2-122]

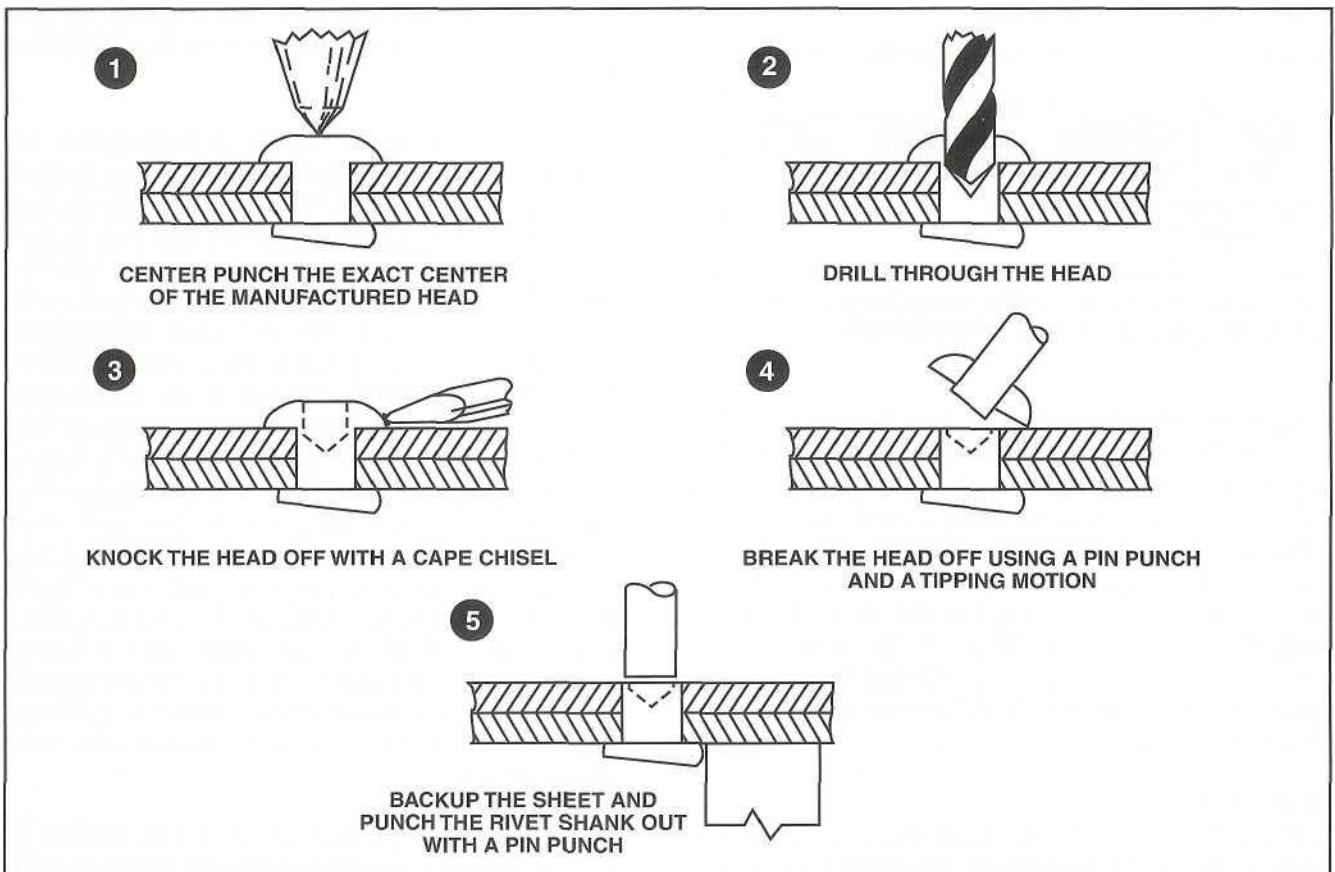

Figure 2-122. When removing a solid rivet, it is important to avoid damaging the sheet metal. Although a cape chisel may be used, removing the rivet head with a pin punch is preferred to help avoid damaging the base metal.

After the rivet head has been removed, back-up the underside of the skin with a bucking bar or piece of wood, and use a pin punch to gently drive the rivet shank from the sheet metal. When the rivet is out, examine the hole, and if it is not elongated, another rivet of the same size may be used as a replacement. If the hole is damaged, use a twist drill for the next larger diameter rivet to re-drill the hole. When using a larger diameter rivet, be sure that the pitch, gauge, and edge distance values are all satisfactory for the pattern.

NACA Flush Riveting

It is possible to drive a rivet in such a way that the shop head will be flush with the outside skin and the protruding manufactured head will be on the inside of the structure. This technique is necessary when a shop head would extend too far beyond a surface and interfere with an adjacent part or cause an unacceptable effect on the aerodynamic characteristics of the structure. To aid manufacturers in standardizing riveting techniques, the **National Advisory Committee for Aeronautics**, or **NACA**, established a set of standards for riveting aircraft and aerospace vehicles. When riveting is conducted to these standards, the process is referred to as NACA riveting. [Figure 2-123]

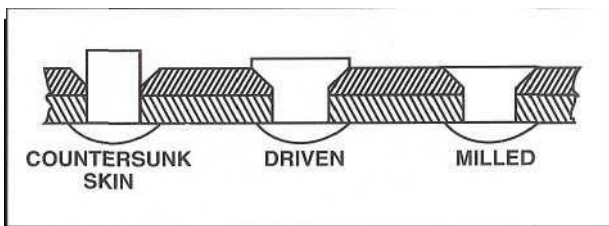

Figure 2-123. The NACA method of riveting produces the smoothest surface possible on a riveted structure.

To perform **NACA riveting**, a hole is drilled and countersunk as it would be for the installation of any flush rivet; however, the rivet is installed from the inside of the structure so its shank sticks out through the countersunk side. When the rivet is driven, the shank is upset to fill the countersunk hole and is allowed to stick up a few thousandths of an inch above the surface. When all the rivets have been driven, a microshaver is adjusted to mill the excess material from the shank to obtain a flush surface. [Figure 2-124]

Team Riveting

When sheet metal parts are riveted onto a complete airframe or a large component, it is often necessary for a person to be on one side of the structure to hold the bucking bar while another person operates

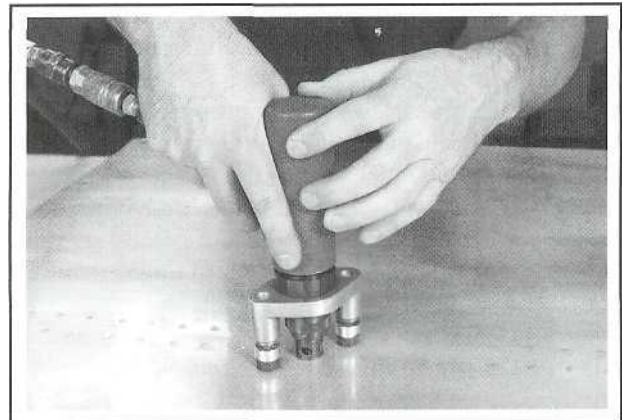

Figure 2-124. A microshaver is used to smooth the upset ends of rivets driven using NACA techniques.

the rivet gun from the opposite side. This operation is called team riveting and requires a great deal of coordination between the technicians. Since there are often many teams working on the same structure, the noise produced in the shop may make it impossible for team members to verbally communicate with one another. To improve communications between the riveter and the buckler, a method of standardized tapping codes has been developed, whereby the person holding the bucking bar can advise the gun operator as to the condition of a driven rivet.

The gun operator, or driver, is responsible for putting the rivets into the holes and driving each of them the same amount. Once a rivet is placed in a hole, the gun is positioned on the rivet head to prevent it from falling out. The buckler then taps the shank one time as the bucking bar is brought into contact with the rivet. After the driver feels or hears the tap, the gun is operated for a short period to upset the rivet shank. As soon as the driver stops the gun, the buckler removes the bucking bar and examines the rivet. If the rivet is sufficiently driven, the buckler taps on the rivet twice with the bucking bar, and the driver goes on to the next rivet. However, if the rivet needs to be driven more, the buckler will tap only one time and immediately place the bucking bar back on the rivet for subsequent driving. If the rivet is dumped over, or for any other reason is not satisfactory, the buckler taps the rivet three times and the driver circles the rivet head with a grease pencil so it can be identified for later replacement.

In the high-speed production needed to build modern aircraft, good, well-coordinated teams of riveters can keep a production line moving effectively. [Figure 2-125]

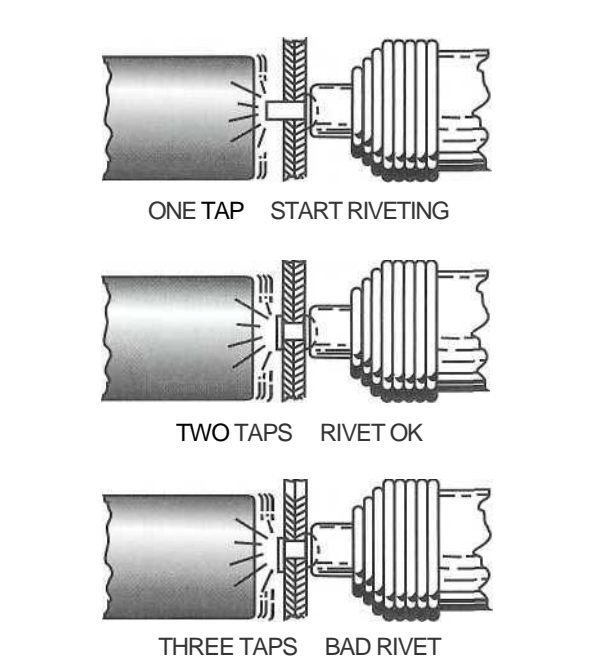

Figure 2-125. A tapping code allows the riveter on one side of the skin to communicate with the buckler on the other side of the structure.

LAYOUT AND FORMING

The fabrication of sheet metal parts for an aircraft requires the technician to have a fundamental knowledge of the physical characteristics of the metal being used, and a working knowledge of applied geometry. In many cases, parts are fabricated from blueprint drawings or are constructed from templates created from pre-existing components. In other cases, the technician must use industry acceptable practices and information from publications such as Advisory Circular 43.13-1B and 2A, *Acceptable Methods and Techniques for Aircraft Alterations and Repairs*, for conducting minor repairs to sheet metal structures. In these situations, the technician must consider the physical characteristics of the metal and perform computations to fabricate parts to the desired dimensions.

When an aircraft is manufactured, fabrication engineers compute all of the bends and cutting dimensions and create dies that can be used in forming machines to speed the manufacturing process. The objective is to allow the metal to be cut to size in one department and formed in another, and yet when the parts are assembled, they all fit properly. However, in field repairs and alterations, it is the technician's responsibility to perform the computations to produce a layout on the sheet metal. A layout is simply the process of placing lines on the metal to distinguish the locations of cuts and bends.

FABRICATION TERMINOLOGY

Fabrication processes require an understanding of the wrought physical characteristics of metals as well as the characteristics of metals when they are shaped or bent. For example, when sheet metal is bent, it must be formed around a radius to allow the metal to gradually change direction. If sheet metal is bent around a sharp corner, the stresses developed will cause fractures during fabrication or while the part is in service. However, when metal is formed around a radius, the amount of material required in the bend will be less than the amount required to form around a sharp corner. Also, since a bend begins and ends at different locations depending on the radius size, it is necessary to compute and layout the location of the bend's starting and ending points to properly position the metal in the forming machine. To understand the methods used in developing sheet metal layouts, it is necessary to consider the physical characteristics of the metal as well as knowing the meaning of various terms used in the fabrication process. [Figure 2-126]

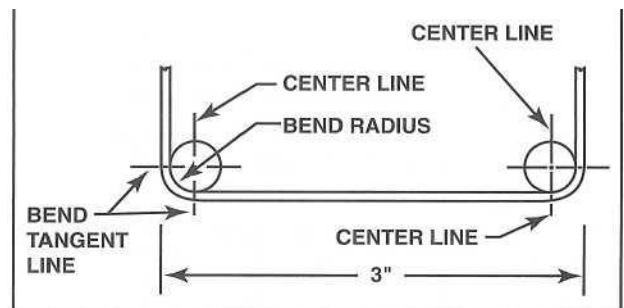

Figure 2-126. When bending sheet metal, a number of factors must be considered. For example, depending on the radius size, the point where the bend begins and ends will vary and must be determined to obtain a desired overall dimension on the flats of the metal.

SHEET METAL GRAIN

Sheet metal used for aircraft construction and repair is formed from ingots of aluminum alloy that are passed through a series of rollers until the metal is reduced to a desired thickness. In the rolling process, the molecules in the metal are elongated in the direction that the metal is passed through the roll. This elongation causes the metal to develop a grain pattern that presents certain physical characteristics that should be considered before forming sheet metal.

Looking closely for small lines that run in one direction through the material distinguishes the grain direction. When bending sheet metal, the strength of the material varies depending on the direction of the bend in relation to the grain. When laying out a pattern, it is better to orient bends to run across, or

perpendicular, to the grain of the metal. If the bend is formed parallel to the grain, the grain boundaries tend to separate and cause cracks. In some cases, the metal will initially fabricate without showing signs of fatigue, but the part may prematurely develop cracks while in service.

BEND RADIUS

Non-aviation sheet metal construction does not require the high strength and light weight that is necessary for aircraft, and so for economy of construction, many metal fabrications have sharp bends. In thin sheet steel, this usually gives no problem, but when working with hard aluminum alloy sheets for aircraft parts, sharp bends must be avoided to prevent cracking. To prevent cracks, a minimum bend radius is recommended for different types of alloys and metal thickness. A radius is measured on the inside of a bend and is generally measured in fractions of an inch. For instance, a common radius for aircraft sheet metal bends is 1/8 inch. This is the distance from the external edge to the center of the radius. [Figure 2-127]

As an example, notice that in the -O, or annealed temper, the metal can be bent over a very small radius, but as the metal's hardness and thickness increases, so does the minimum allowable bend radius. If the metal is bent with too small a radius,

the outside of the bend, which is stretched, will pull the grain boundaries apart, causing the metal to crack. On the other hand, if the metal is bent around a radius that is larger than the minimum size, the area of the bend may be too large to fit in conjunction with adjacent parts.

NEUTRAL AXIS

When bending a piece of metal around a radius, the metal on the outside of the bend stretches, while the metal toward the inside tends to compress or shrink. Within the metal, a portion neither shrinks nor stretches, but retains its original dimension. The line along which this occurs is called the neutral axis of the metal. This line is not located exactly in the center of the sheet, but is actually about 44.53% of the sheet thickness from the inside of the bend.

Occasionally it is necessary to know the exact length of the neutral axis, but for most practical purposes, you can assume the neutral axis is located in the center of the metal. The slight error from this approximation is usually too small for consideration when constructing a layout pattern.

MOLD LINE

Mold lines are used to designate the dimensions of a piece of metal on a drawing or layout pattern. These are formed by extending a line from the exter-

Alloy and temper	APPROXIMATE SHEET THICKNESS (t) (inch)					
	0.016	0.032	0.064	0.128	0.182	0.258
2024-0 ¹	0	0-1t	0-1t	0-1t	0-1t	0-1t
2024-T3 ^{1, 2}	1 1/2t-3t	2t-4t	3t-5t	4t-6t	4t-6t	5t-7t
2024-T6 ¹	2t-4t	3t-5t	3t-5t	4t-6t	5t-7t	6t-10t
5052-0	0	0	0-1t	0-1t	0-1t	0-1t
5052-H32	0	0	1/2t-1t	1/2t-1 1/2t	1/2t-1 1/2t	1/2t-1 1/2t
5052-H34	0	0	1/2t-1 1/2t	1 1/2t-2 1/2t	1 1/2t-2 1/2t	2t-3t
5052-H36	0-1t	1/2t-1 1/2t	1t-2t	1 1/2t-3t	2t-4t	2t-4t
5052-H38	1/2t-1 1/2t	1t-2t	1 1/2t-3t	2t-4t	3t-5t	4t-6t
6061-0	0	0-1t	0-1t	0-1t	0-1t	0-1t
6061-T4	0-1t	0-1t	1/2t-1 1/2t	1t-2t	1 1/2t-3t	2 1/2t-4t
6061-T6	0-1t	1/2t-1 1/2t	1t-2t	1 1/2t-3t	2t-4t	3t-4t
7075-0	0	0-1t	0-1t	1/2t-1 1/2t	1t-2t	1 1/2t-3t
7075-T6 ¹	2t-4t	3t-5t	4t-6t	5t-7t	5t-7t	6t-10t

¹ Alclad sheet may be bent over slightly smaller radii than the corresponding tempers of uncoated alloy.

² Immediately after quenching, this alloy may be formed over appreciably smaller radii.

Figure 2-127. The type of alloy, temper, and thickness of sheet metal determines the minimum bend radius.

nal side of the metal, out beyond the radius of a bend. Although the mold lines themselves do not include dimensions, they are used as reference points from where dimensions can be established.

MOLD POINT

The point where two mold lines intersect in a bend is referred to as a mold point. When a piece of sheet metal is laid out, all of the measurements are made from one mold point to the next. However, the actual corner of the formed metal does not reach the mold point because of the bend radius. On the other hand, by measuring from the mold point, the position where the bend should start can be located.

BEND TANGENT LINE

Bend tangent lines are generally shown on blueprints and drawings to designate the location where the sheet metal begins to form around the bend radius. When positioning metal into a forming brake, the metal is inserted so that the bend tangent line is located under the back edge of the bend radius. Since the line is positioned under the radius, it is difficult to see the tangent line's location.

To enable more accurate positioning, a sight line is marked off from the bend tangent line. The distance of the sight line from the bend tangent is the same dimension as the radius. For example, if a 1/8 inch radius is used, the sight line is marked 1/8 inch or .125 inch ahead of the bend tangent line. When the metal is placed in the brake, the sight line is positioned directly under the nose of the radius forming block. This will cause the bend tangent line to be located at the approximate position of the beginning of the radius curvature.

SETBACK

The distance between the mold line and the bend tangent line inside the bend area is referred to as the setback dimension. When determining where a bend will begin, it is necessary to subtract the setback amount from the desired dimension of the flat. For a 90 degree bend, the setback is found by adding the dimension of the bend radius to the thickness of the metal. For example, the setback for a 90-degree bend in .040 inch thick material with a 1/8 inch radius would be equal to .165 inches (.125 + .040). If a flat with a developed width of 3 inches were desired with one end bent, the bend tangent line would be located at 2.835 inches. However, where two bends are formed on each end of a flat, it is necessary to subtract the setback twice from the desired developed width of the flat. [Figure 2-128]

On the other hand, for bends greater or less than 90 degrees, it is necessary to compensate the setback amount by applying an additional multiplier to the

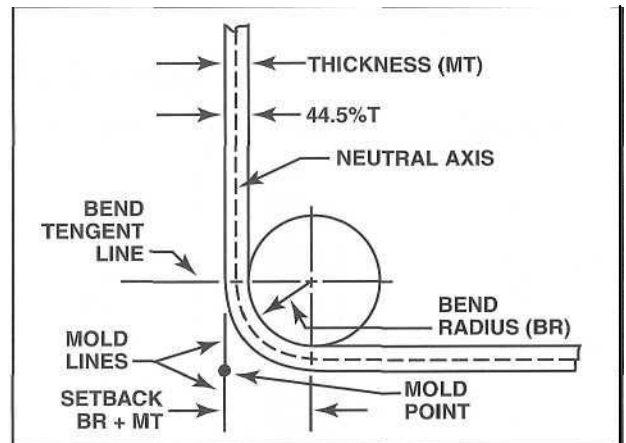

Figure 2-128. The setback for a 90 degree bend is equal to the dimension of the radius plus the metal thickness (Setback = BR + MT).

formula, which is commonly referred to as a K-value. The K-value takes into account that when the metal is bent to an angle 90 degrees, the mold point of the bend will move a certain distance. The direction the mold point moves is dependent on whether the bend has an open or closed angle. [Figure 2-129]

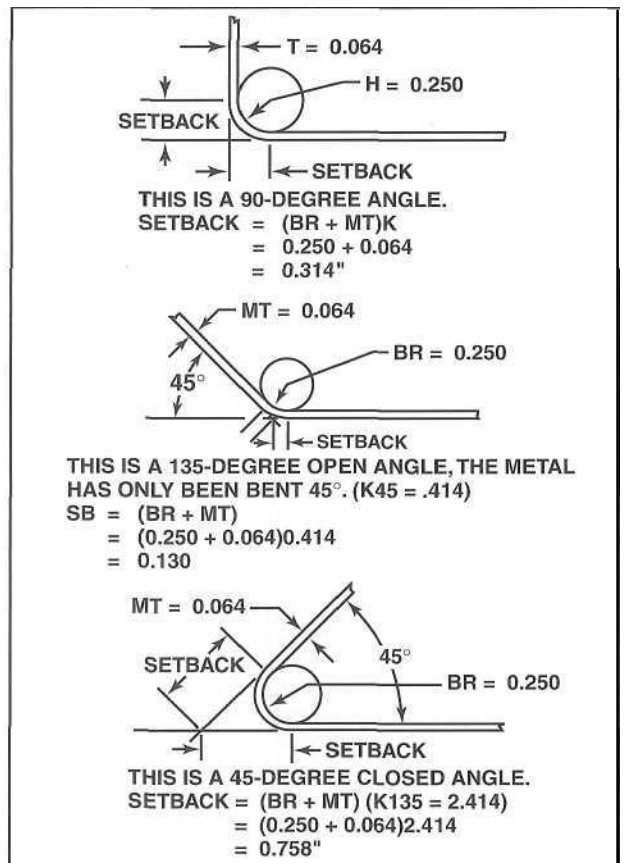

Figure 2-129. As shown in these diagrams, a closed angle bend requires the metal to be bent more than 90 degrees, whereas bending the metal less than 90 degrees develops an open angle.

For bends other than 90° Setback = k [R+T]					
Ang [deg]	K value	Ang [deg]	K value	Ang [deg]	K value
1	0.00873	61	0.58904	121	1.7675
2	0.01745	62	0.60086	122	1.8040
3	0.02618	63	0.61280	123	1.8418
4	0.03492	64	0.62487	124	1.8807
5	0.04366	65	0.63707	125	1.9210
6	0.05241	66	0.64941	126	1.9625
7	0.06116	67	0.66188	127	2.0057
8	0.06993	68	0.67451	128	2.0503
9	0.07870	69	0.68728	129	2.0965
10	0.08749	70	0.70021	130	2.1445
11	0.09629	71	0.71329	131	2.1943
12	0.10510	72	0.72654	132	2.2460
13	0.11393	73	0.73996	133	2.2998
14	0.12278	74	0.75355	134	2.3558
15	0.13165	75	0.76733	135	2.4142
16	0.14054	76	0.78128	136	2.4751
17	0.14945	77	0.79543	137	2.5386
18	0.15838	78	0.80978	138	2.6051
19	0.16734	79	0.82434	139	2.6746
20	0.17633	80	0.83910	140	2.7475
21	0.18534	81	0.85408	141	2.8239
22	0.19438	82	0.86929	142	2.9042
23	0.20345	83	0.88472	143	2.9887
24	0.21256	84	0.90040	144	3.0777
25	0.22169	85	0.91633	145	3.1716
26	0.23087	86	0.93251	146	3.2708
27	0.24008	87	0.94890	147	3.3759
28	0.24933	88	0.96569	148	3.4874
29	0.25862	89	0.98270	149	3.6059
30	0.26795	90	1.0000	150	3.7320
31	0.27732	91	1.0176	151	3.8667
32	0.28674	92	1.0355	152	4.0108
33	0.29621	93	1.0538	153	4.1653
34	0.30573	94	1.0724	154	4.3315
35	0.31530	95	1.0913	155	4.5107
36	0.32492	96	1.1106	156	4.7046
37	0.33459	97	1.1303	157	4.9151
38	0.34433	98	1.1504	158	5.1455
39	0.35412	99	1.1708	159	5.3995
40	0.36397	100	1.1917	160	5.6713
41	0.37388	101	1.2131	161	5.9758
42	0.38386	102	1.2349	162	6.3137
43	0.39391	103	1.2572	163	6.6911
44	0.40403	104	1.2799	164	7.1154
45	0.41421	105	1.3032	165	7.5957
46	0.42447	106	1.3270	166	8.1443
47	0.43481	107	1.3514	167	8.7769
48	0.44523	108	1.3764	168	9.5144
49	0.45573	109	1.4019	169	10.385
50	0.46631	110	1.4281	170	11.430
51	0.47697	111	1.4550	171	12.706
52	0.48773	112	1.4826	172	14.301
53	0.49858	113	1.5108	173	16.350
54	0.50952	114	1.5399	174	19.081
55	0.52057	115	1.5697	175	22.904
56	0.53171	116	1.6003	176	26.636
57	0.54295	117	1.6318	177	38.138
58	0.55431	118	1.6643	178	57.290
59	0.56577	119	1.6977	179	114.590
60	0.57735	120	1.7320	180	Infinite

Figure 2-130. A K-chart is used to simplify the problem of determining the setback value for bends other than 90 degrees. To determine the setback with a K-chart, use the number of degrees the metal is bent from the flat layout position.

K-values for determining the setback of bends are usually available on charts. These charts make the computations of setbacks for other than 90 degrees rather simple. Once the K-value for the bend is known, the setback is easily found by adding the radius plus the metal thickness and then multiplying by the K-value (S.B. = K x (R + T)). However, if a chart is not available, the K-value can be determined mathematically with most calculators that are capable of performing trigonometric functions, or by using a trigonometric table. To determine the K-value with a calculator or table, find the tangent of one-half the degrees of bend. [Figure 2-130]

For example, to determine the K-value for a closed angle bend of 50 degrees in .040 inch thick material using a 1/8 inch radius, use the following procedures. First, determine the number of degrees the metal will actually be bent from the flat layout position. In this situation, the metal will be bent a total of 130 degrees (180 degrees - 50 degrees = 130 degrees). Next, find the K-value for the degrees of bend. In this example, the K factor is equal to the tangent of one half the bend angle (65 degrees), which is equal to 2.144 inches.

Keep in mind that if a K-chart is used, merely refer to the K-value for the number of bend angle degrees. To complete the setback problem, add the radius (.125 inch) to the metal thickness (.040 inch) and multiply that value by the K factor (2.144 inch x .165 inch = .35376 inch).

FLATS

The distance between inside bend tangent lines from one bend to another, or from the end of a piece of metal to the first bend tangent line is called a flat. This is the amount of metal that is not bent. The length of the flats will always be less than the desired developed width because the bend is setback into the flat.

BEND ALLOWANCE

Bend allowance is the amount of material that is actually involved in the bend and is equal to the length of the neutral axis. When determining the total developed length of a layout pattern, the bend allowance values are added to the lengths of the flats. One method of computing a bend allowance assumes the neutral axis to be located in the exact center of the metal. While this may not be the most accurate method, the final computation is reasonably close and works well for most applications.

To compute a bend allowance, begin by finding the circumference of a circle with a radius equal to the

bend radius, plus the thickness of the metal. Since the circumference of a circle is equal to n (3.1415) times diameter (πD), begin by finding the diameter by doubling the radius and then add the thickness of the metal. For example, for a 1/8 inch radius and .040 inch thick metal, the diameter of the circle would be .25 inch (.125 x 2) plus .040 inch for a total diameter of .290 inch.

Next, find the circumference by multiplying the diameter by n (.290 x 3.1415), which for this purpose can be rounded to .911 inch. This would be the amount of metal necessary to make a bend to form an entire circle. To determine the bend allowance for the desired bend angle, it is necessary to divide the circumference by 360 degrees to find the amount of material required for each degree of bend. The amount of material in the example would be found by dividing .911 inches by 360 degrees, which is equal to .0025 inches/degree. This answer multiplied by the number of degrees of the desired bend will be the total bend allowance. For instance, for a 45 degree bend, the bend allowance will be equal to .0025 inches times 45 degrees, which is equal to .1125 inches. This is the approximate amount of material used in the bend. [Figure 2-131]

Another method of finding the bend allowance, which produces accurate results, is found by using an empirical formula. This formula provides for the bend allowance to be located in the actual position

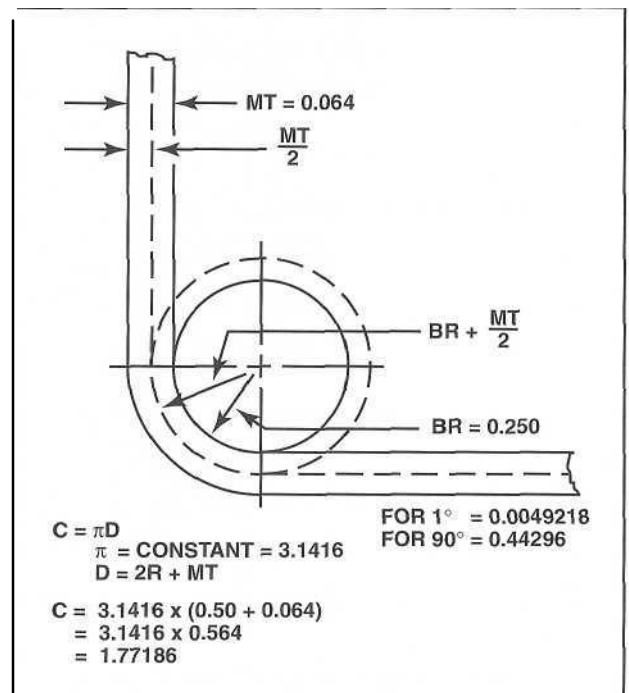

Figure 2-131. One method of finding the bend allowance assumes the neutral axis to be in the center of the metal.

of the neutral axis. The formula for determining the bend allowance for one degree of bend is:

$$\text{Bend Allowance} = (.0078T + .01743R)$$

The bend allowance for the previous example by the use of this formula is:

$$\begin{aligned} \text{B.A.} &= (.0078 \times .040 + .01743 \times .125) \times \\ 45 &= (.000312 + .00218) \times 45 = .002492 \\ X45 &= .11214 \end{aligned}$$

The empirical formula has been used to compile a table that is found in many aircraft technician and sheet metal fabrication handbooks. With most of these charts, the bend allowance for a 90 degree bend is shown along with the amount of bend allowance for each degree of bend. [Figure 2-132]

Notice that the computation using the first formula versus using a bend allowance chart is within a few ten thousandths inch of each other. For practical purposes, this degree of accuracy is acceptable for most sheet metal fabrications, so either method may be used.

COMPUTATIONS FOR LAYOUTS

To fabricate a sheet metal part with bends, a pattern is first drawn on flat metal to determine the locations of the bend tangent and sight lines, as well as the locations for cutting the metal to the proper length and width. To begin the process, computations are made to determine the dimensions of the flats and locations of the bend tangent lines. For example, to form 2024-T3 aluminum that is 0.032 inch thick into a 4 inch long by 2 inch deep and 2 inch wide U-shaped channel, a layout pattern is cal-

METAL GAUGE	RADIUS OF BEND IN INCHES													
	1/32 .032	1/16 .063	3/32 .094	1/8 .125	5/32 .156	3/16 .188	7/32 .219	1/4 .250	9/32 .281	5/16 .313	11/32 .344	3/8 .375	7/16 .438	1/2 .500
.020	.062 .000693	.113 .001251	.161 .001792	.210 .002333	.259 .002874	.309 .003433	.358 .003974	.406 .004515	.455 .005056	.505 .005614	.554 .006155	.603 .006695	.702 .007795	.799 .008877
.025	.066 .000736	.116 .001294	.165 .001835	.214 .002376	.263 .002917	.313 .003476	.362 .004017	.410 .004558	.459 .005098	.509 .005657	.558 .006198	.607 .006739	.705 .007838	.803 .008920
.028	.068 .000759	.119 .001318	.167 .001859	.216 .002400	.265 .002941	.315 .003499	.364 .004040	.412 .004581	.461 .005122	.511 .005680	.560 .006221	.609 .006762	.708 .007862	.805 .008962
.032	.071 .000787	.121 .001345	.170 .001886	.218 .002427	.267 .002968	.317 .003526	.366 .004067	.415 .004608	.463 .005149	.514 .005708	.562 .006249	.611 .006789	.710 .007889	.807 .008971
.038	.075 .000837	.126 .001396	.174 .001937	.223 .002478	.272 .003019	.322 .003577	.371 .004118	.419 .004659	.468 .005200	.518 .005758	.567 .006299	.616 .006840	.715 .007940	.812 .009021
.040	.077 .000853	.127 .001411	.176 .001952	.224 .002493	.273 .003034	.323 .003593	.372 .004134	.421 .004675	.469 .005215	.520 .005774	.568 .006315	.617 .006856	.716 .007955	.813 .009037
.051		.134 .001413	.183 .002034	.232 .002575	.280 .003116	.331 .003675	.379 .004215	.428 .004756	.477 .005297	.527 .005855	.576 .006397	.624 .006934	.723 .008037	.821 .009119
.064		.144 .001595	.192 .002136	.241 .002676	.290 .003218	.340 .003776	.389 .004317	.437 .004858	.486 .005399	.536 .005957	.585 .006498	.634 .007039	.732 .008138	.830 .009220
.072			.198 .002202	.247 .002743	.296 .003284	.346 .003842	.394 .004383	.443 .004924	.492 .005465	.542 .006023	.591 .006564	.639 .007105	.738 .008205	.836 .009287
.078			.202 .002249	.251 .002790	.300 .003331	.350 .003889	.399 .004430	.447 .004963	.496 .005512	.546 .006070	.595 .006611	.644 .007152	.745 .008252	.840 .009333
.081			.204 .002272	.253 .002813	.302 .003354	.352 .003912	.401 .004453	.449 .004969	.498 .005535	.548 .006094	.598 .006635	.646 .007176	.745 .008275	.842 .009457
.091			.212 .002350	.260 .002891	.309 .003432	.359 .003990	.408 .004531	.456 .005072	.505 .005613	.555 .006172	.604 .006713	.653 .007254	.752 .008353	.849 .009435
.094			.214 .002374	.262 .002914	.311 .003455	.361 .004014	.410 .004555	.459 .005096	.507 .005637	.558 .006195	.606 .006736	.655 .007277	.754 .008376	.851 .009458
.102				.268 .002977	.317 .003518	.367 .004076	.416 .004617	.464 .005158	.513 .005699	.563 .006257	.612 .006798	.661 .007339	.760 .008439	.857 .009521
.109				.273 .003031	.321 .003572	.372 .004131	.420 .004672	.469 .005213	.518 .005754	.568 .006312	.617 .006853	.665 .007394	.764 .008493	.862 .009575
.125				.284 .003156	.333 .003697	.383 .004256	.432 .004797	.480 .005338	.529 .005879	.579 .006437	.628 .006978	.677 .007519	.776 .008618	.873 .009700
.156					.355 .003939	.405 .004497	.453 .005038	.502 .005579	.551 .006120	.601 .006679	.650 .007220	.698 .007761	.797 .008860	.895 .009942
.188						.417 .004747	.476 .005288	.525 .005829	.573 .006370	.624 .006928	.672 .007469	.721 .008010	.820 .009109	.917 .010191
.250								.568 .006313	.617 .006853	.667 .007412	.716 .007953	.764 .008494	.863 .009593	.961 .010675

Figure 2-132. A bend allowance chart provides the bend allowance for a 90-degree bend and for individual degrees of bend for various thickness metal and bend radii. The bend allowance for 90 degree bends is shown on top while the bend allowance for each degree of bend is shown in the bottom of each box.

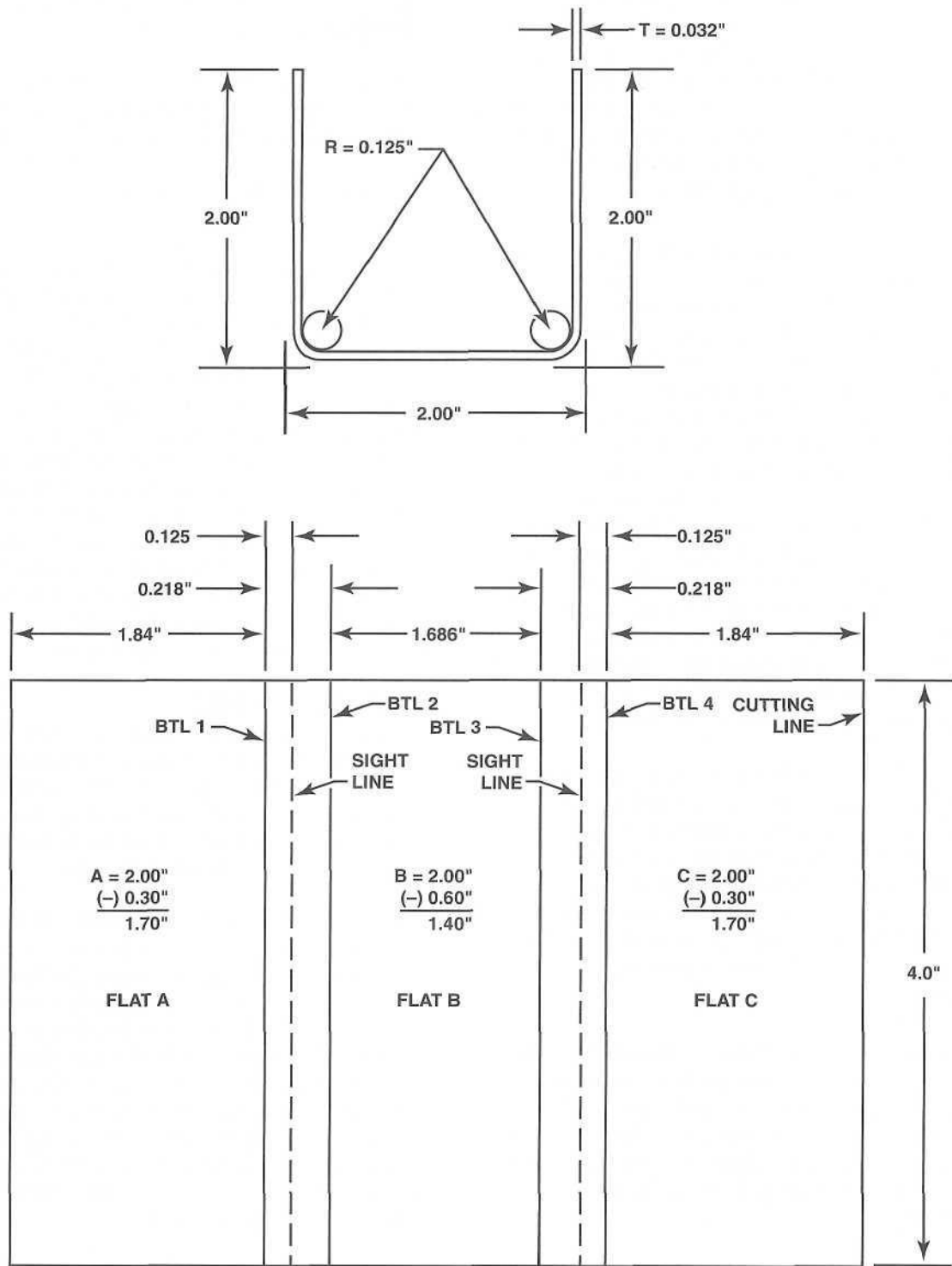

Figure 2-133. The flat pattern layout includes bend tangent lines and sight lines, which are used for bending the metal in a sheet metal brake.

culated and marked in the following manner. [Figure 2-133]

First, begin by finding the minimum radius that will be used to fabricate the bends. In many applica-

tions, blueprints or other manufacturing information will specify the radius to use. However, if it is not given, the minimum radius can be determined by referring to a chart similar to the one previously shown in Figure 2-127. For this example, it is found

that the minimum radius for 2024-T3 aluminum that is .032 inch thick is between 2 to 4 times the metal thickness, or .064 inch to .128 inch. Converted to the nearest fractional equivalent, the minimum radius would need to be at least $\frac{3}{32}$ inch, but $\frac{1}{8}$ inch provides for a larger radius to help prevent cracking. For this example, $\frac{1}{8}$ inch will be used for fabricating the bends.

Once the minimum bend radius has been determined, it is necessary to find the setback value for the bends. This value is used numerous times in establishing the dimensions in the layout pattern since both bends for the U-shaped channel will be fabricated to 90 degrees. For 90-degree bends, the setback is equal to the bend radius (.125) plus the metal thickness (.032), which equals .157 inch. By subtracting the setback value from each of the mold line dimensions, the lengths of the flats and locations for the bend tangent lines can be determined. To layout the pattern, begin from one end of the metal and progressively mark the bend tangent lines as each location is calculated. For most layout patterns, computations carried out to the nearest hundredth inch are adequate. Mark the metal with a fine tipped marker, orienting it, if practical, so the bends will be made across the grain of the metal.

The first bend tangent line is marked at a distance from the end of the metal that is equal to the mold line dimension, minus the setback. For this example, the mold line dimension for flat A is 2 inches, which will mean the first bend tangent line will be marked at 1.843 inches or 1.84 inches from the end. Next, a second bend tangent line is marked off from the first line, at a distance equal to the bend allowance.

By referring to the chart shown in Figure 2-132, the bend allowance for .032 inch thick aluminum using a $\frac{1}{8}$ inch radius is found to equal .218 inch for 90 degree bends. Mark the second bend tangent line on the layout pattern approximately .218 inch away from the first bend tangent line on the side toward the next flat.

From the second bend tangent line, it is necessary to determine the length of flat B to locate the position of the third bend tangent line. The length of flat B is found by subtracting the setback amount twice from the desired developed width of flat B. The two setback values are subtracted to account for the bends at each end of the flat. In this example, the developed width of flat B is 2 inches, so the length of flat B would be 1.686 inches. The third bend tangent

line is then marked 1.686 inches from the second bend tangent line.

The final bend tangent line is located at a distance that is equal to the bend allowance away from the third bend tangent line. Since both bends are the same, the bend allowances are also the same. This means the final bend tangent line is marked .218 inch from the third line.

To complete the layout, it is necessary to locate where the metal needs to be cut for length, and then sight lines must be established if a bending brake will be used to fabricate the channel. Since the length of flat C is the same as flat A, the cutting line should be marked 1.84 inches from the fourth bend tangent line. Once the metal is cut on a squaring shear, deburr the edges before bending the metal. As a last step, sight lines are marked depending on how the metal will be positioned in the brake for bending. The sight lines are marked off from the bend tangent line that will be placed under the nose of the brake, at a distance equal to the bend radius used. For this example, the sight lines are marked .125 inch from the bend tangent line.

FORMING BENDS

To form bends using a Cornice or finger brake, begin by verifying that the proper size radius blocks are installed in the upper jaw. For most brakes, the blocks are stamped with the size. However, if the block is not marked, it may be necessary to use a radius gauge to determine the size.

Once the radius has been verified, adjust the nose of the blocks so they are back from the edge of the bending leaf by a distance equal to the thickness of the metal. Once adjusted, open the jaws of the brake and slip the metal in place, lining it up so that looking straight down reveals that the sight line is even with the nose of the radius block. Clamp the jaws of the brake and raise the leaf to the desired angle. Since all sheet metal has some spring-back, the leaf will need to be brought through the desired angle by a few degrees to achieve the properly finished dimension. [Figure 2-134]

When making more than one bend, consider the possibility of the upper jaw of the brake interfering with flats that have already been made. In some cases, the radius blocks may need to be spaced apart so that bent flats can come up along the sides of the blocks. However, if the bend cannot be completely formed because of interference, bumping the metal down with a plastic or rubber mallet over a hardwood block can do the finished shaping.

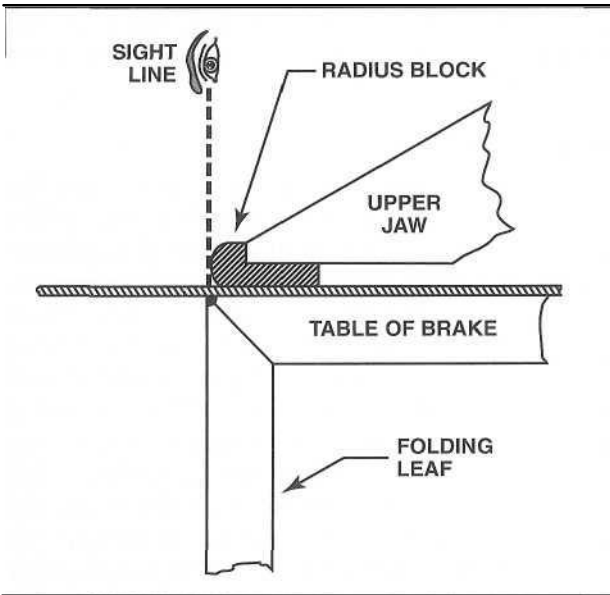

Figure 2-134. The sheet metal being bent should be placed in the brake so that the sight line, which is one radius from the bend tangent line in the brake, is directly beneath the nose of the bend radius blocks.

To perform shaping in this manner, clamp the metal in a vise between a hardwood block that has a radius formed on one edge, and a second hardwood block to prevent damage to the metal from the clamp. Once secured, bump the metal down over the radius block by using a mallet and a piece of hardwood. Use as few blows as possible and spread the force out over as large a distance as possible with the wood block. [Figure 2-135]

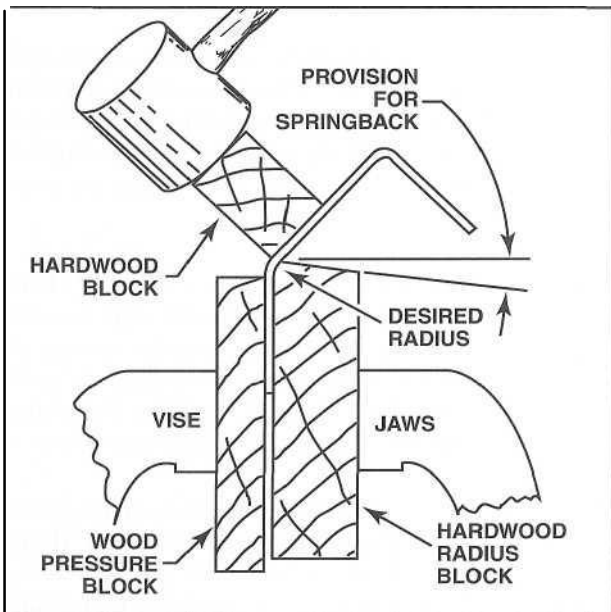

Figure 2-135. When it is not possible to complete a bend in a brake, blocks of wood and a mallet are used to finish the bend.

FOLDING A BOX

One of the most common sheet metal parts that a technician is required to fabricate is a four walled box. Although bending these boxes is similar to forming a U-channel, a few additional processes must be performed. As a project, examine the procedure needed to lay out and form a box of .051 inch 2024-T3 clad aluminum alloy. The box is to be 4 inches square and have sides that are 1 inch high. All of the dimensions are mold line dimensions, and the bend radius will be 5/32 inch. [Figure 2-136]

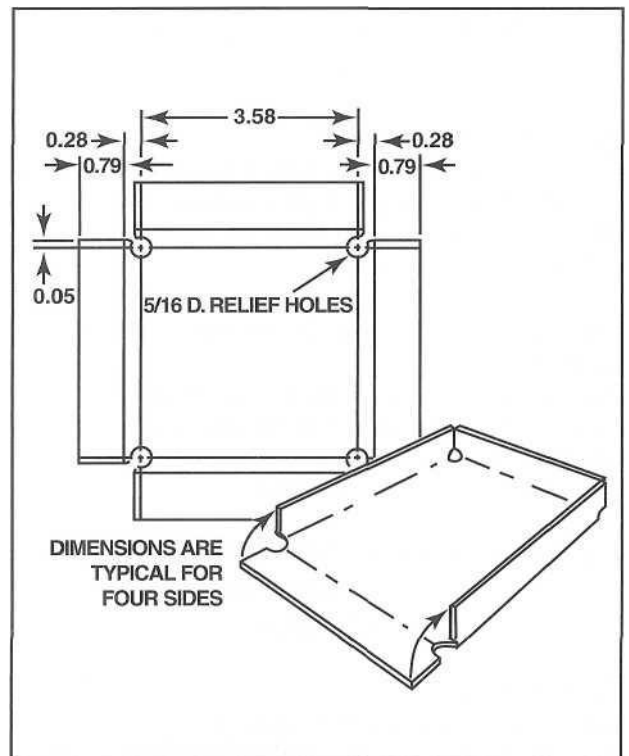

Figure 2-136. The flat pattern layout for a box is similar to a U-channel except that relief holes must be drilled at the inner bend tangent lines to prevent the metal from cracking at the intersection of the bends. In addition, cutting lines must also be marked for material to be removed so the corners can be fabricated.

Determining setback

All of the bends used in this box are 90 degrees, so the setback will be the sum of the bend radius and the metal thickness, or:

$$\begin{aligned} \text{Setback} &= \text{Bend Radius} + \text{Metal Thickness} \\ &= .156 \text{ inch} + .051 \text{ inch} \\ &= .207 \text{ inch} \end{aligned}$$

Round this off to .21 inch.

Find the length of the flats for the sides

The mold line lengths for the sides are all 1 inch, so the flats of the sides will be this amount less one setback:

$$\begin{aligned}\text{Side} &= 1.00 \text{ inch} - .21 \text{ inch} \\ &= .79 \text{ inch}\end{aligned}$$

Find the length of the flat for the bottom

The mold line length for the bottom is 4 inches, and since there is a setback dimension at each end of this, the flat for the bottom will be:

$$\begin{aligned}\text{Bottom} &= 4.00 \text{ inches} - .42 \text{ inches} \times 2 = \\ &= 3.58 \text{ inches}\end{aligned}$$

Find the bend allowance

Use the chart of Figure 2-132 on page 2-74 and follow the 5/32 inch bend radius column down to the .051 inch thickness line. For a 90 degree bend, .280 inch of material is needed.

Find the length of the developed width for the material

Since the box is to be square, a square piece of metal equal to the sum of the three flats and two bend allowances is needed. For this example, the developed width is found as follows:

$$\begin{aligned}\text{Developed Width} &= .79 \text{ inch} + .28 \text{ inch} + 3.58 \text{ inches} \\ &\quad + .28 \text{ inch} + .79 \text{ inch} \\ &= 5.72 \text{ inches.}\end{aligned}$$

Lay out the box

Cut a square 5.72 inches on each side, remove all of the burrs, and mark the bend tangent lines in from the edges, equal to the flat dimensions for the walls of the box, or at .79 inch. Make these marks with a fine tipped marker, being careful not to scratch the metal. From these marks, make a second line inside each at a distance equal to the bend radius, or at .28 inch. These lines form the inside and outside locations where the bends begin and end.

Since the bends intersect in the corners, the metal will tend to crack if relief holes are not drilled. A good rule of thumb for relief holes is to use a diameter of twice the bend radius, with the holes centered at the intersection of the inner bend tangent lines. The sight line and the ends of each of the sides will be tangent to these holes.

Cut the material

Drill the relief holes and then use a deburring tool to smooth the edges of the holes. Then cut out the

material at each of the corners. Once the metal has been cut to shape, smooth all the edges and corner cuts using a fine toothed file.

Bend the box

A box, or pan brake, should be used to bend the sides. These brakes resemble a leaf brake except that the upper jaw is made up of a series of segmented blocks. These blocks vary in width and can be positioned to accommodate the bent walls of the box as previously mentioned. Once two opposite sides of the box are bent, position the upper jaw of the brake to fit between the formed sides. When the leaf is raised, the two sides will ride up in the slots between the fingers. When using a conventional leaf brake, form two opposite sides on the brake and then bend the remaining sides over a forming block, using a block of hardwood and mallet as previously described in the procedure for forming a channel.

COMPOUND CURVES AND CONTOURS

A part made of thin sheet metal can be considerably stiffened without any increase in its weight by designing it to have compound curves. In addition, sheet metal parts can be made into shapes that allow a part to be used for aerodynamic streamlining. These curves can be fabricated by a number of different methods including hand or machine forming. With hand forming, considerable experience is necessary to make some of the more complex parts that have unique shapes. However, for simple forming, patterns can be used to fabricate contours and curves.

When a repair must be made that requires a compound curved part, it is more economical to buy the part from the factory than it is to fabricate it in the shop. But sometimes parts are not available and the technician must resort to hand forming a replacement.

When a straight bend is made in a piece of sheet metal, the inside of the bend is shrunk and the outside is stretched, but no metal is actually moved, or displaced. When a compound curve is formed, however, metal must be displaced, and the shrinking and stretching take place in more than one plane.

An example of a part that is occasionally hand formed, is an extruded bulb angle stringer. These stringers are used in semimonocoque structures because of the resistance of the metal to distortion. In Figure 2-137, if a load is placed on a bulb angle, it is opposed by the entire width of flat A, which is stiffened by flat B and the bulb. In order to bend, the

top side of flat A will have to stretch while flat B and the bulb will have to shrink.

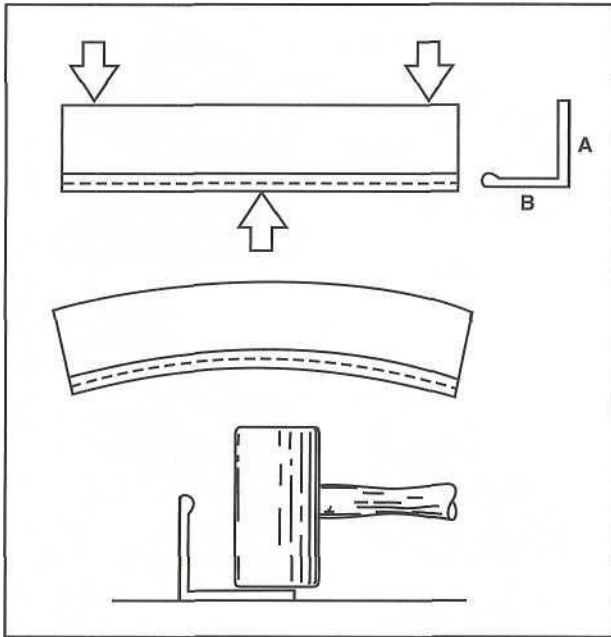

Figure 2-137. Extruded bulb angles are used for stringers in many aircraft. To form a convex curve in a stringer of this type, the metal on the flat with the bulb angle must be stretched. This can be accomplished by bumping the metal with a mallet against a round hardwood block.

To shape a bulb angle to fit the contour of a skin, the thickness of flat A must be reduced by hammering it. Although no metal is removed by hammering, the material that is moved when the thickness is reduced goes to increasing the length of the part. When the outside of flat A is lengthened, flat B, and the bulb, will bend. This method of forming can be used only for very gentle bends, but stringers seldom require more than a slight curvature.

It is more likely required to form a bulb angle into a convex curve than into a concave shape. To do this, the edge of flat A must be shrunk. This can be done, but requires more care than stretching the metal. To form a concave shape, use a V-block made of wood, and hammer on the edge of the flat. Do not hit it hard enough to buckle it. Move the angle back and forth over the V-block as the metal is hit so it will shrink uniformly over the entire bend. Only through practice will the skill be developed to use blows hard enough to minimize work-hardening and yet not too hard to buckle the flat. [Figure 2-138]

One of the best projects that can be performed to develop the skills needed in hand forming aluminum is done by forming a compound curved

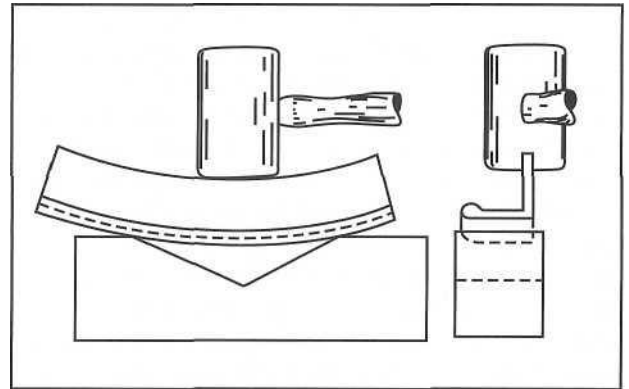

Figure 2-138. A concave curve can be formed in a bulb angle by shrinking the flange over a V-block made of hardwood.

channel. Forming these channels requires considerable stretching on one side of the part and shrinking on the other.

To form a compound curved channel, begin by making a hardwood forming block. Cut the block to the exact shape and size of the inside of the desired channel dimension. Then round the edges with a radius that is greater than the minimum radius allowed for the material that will be used for the part. Taper the edges of the block back about three degrees to allow for spring-back, so the final bend will be a true right angle. Once the first block is made, cut a second block of the proper size and shape so it comes just to the beginning of the bend radius. Drill three holes through both pieces to be used for bolts or other devices to keep the forming blocks and the material from shifting during forming. [Figure 2-139]

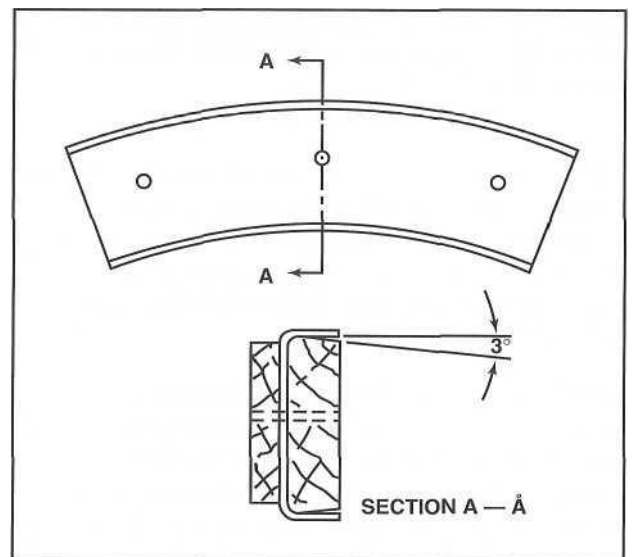

Figure 2-139. A compound curved channel can be formed using two hardwood blocks clamped in a vise.

Lay out the flat pattern for the metal to be bent. Consider the bend allowance when laying out the material, but leave it slightly larger than needed so it can be trimmed to the final size after forming. However, do not allow too much extra material as this will also have to be shrunk and stretched, and too much material can make the project far more difficult. Drill the tooling holes in the metal to match those in the forming blocks. Once drilled, put the metal between the blocks, securing them with the proper size pins or bolts, and clamp the assembly in a vise with the concave side up. Start near the ends of the curve and back the metal with a piece of tapered hardwood. Strike the metal with a plastic mallet as near the bend tangent line as possible. Work from each end toward the middle, folding the metal over just a little each time it is hit. Some buckling will occur, but it can be worked out as the bend progresses across the entire concave side. [Figure 2-140]

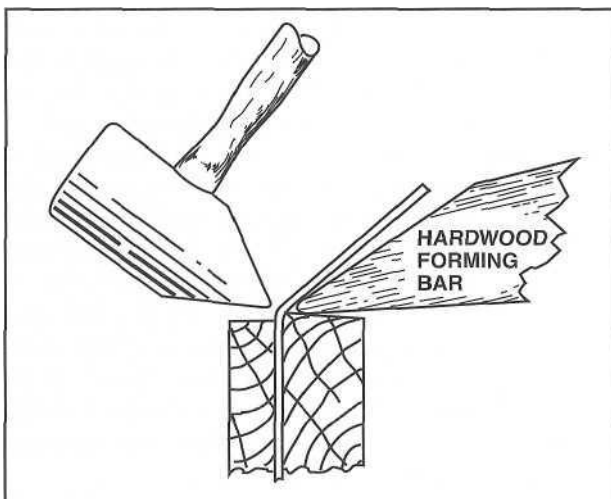

Figure 2-140. When forming a compound curve, the metal should be backed up with a hardwood forming bar for better control of the bend.

Skill in making this kind of bend comes only from practice. A technician must develop a feel for the material so it can be formed with as few blows as possible, to prevent work-hardening the metal, while not creating any big buckles that cannot be worked out.

Once the flats have been formed, turn the assembly over and form the convex side. Back up the material with the tapered block and strike the metal near the bend, but this time start at the center and work outward toward each end. When stretching, as when shrinking, use as few blows as possible so the material will not crack or create wrinkles that cannot be worked out. [Figure 2-141]

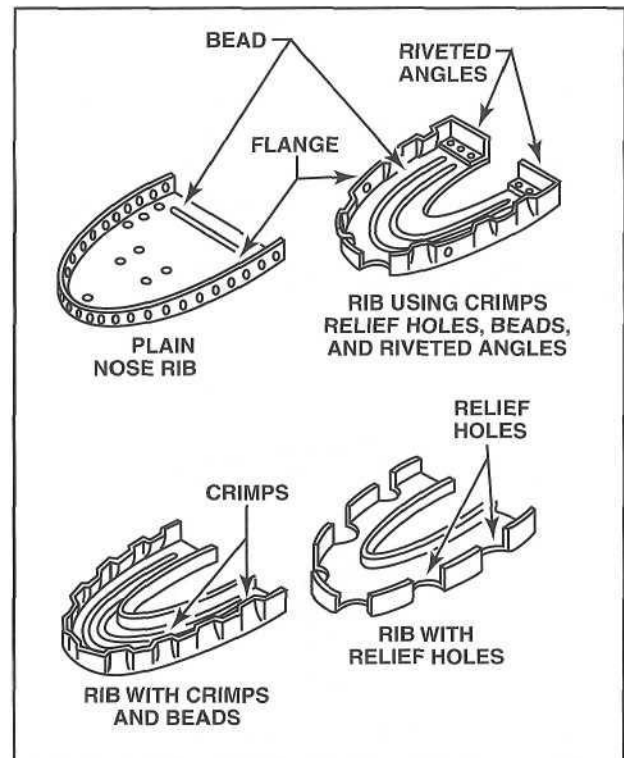

Figure 2-141. Many types of components and aircraft structures can be formed using hand-shrinking and stretching. For example, several different versions of nose ribs can be reproduced using hand-shrinking and stretching, as shown here.

BUMPING

It may sometimes be necessary to form a streamline cover for some component that must protrude into the air stream. These parts are usually nonstructural and are much more easily made of fiberglass reinforced resins, but occasionally they are made from aluminum alloy sheet metal.

An example of a part that can be formed by bumping is used to cover bellcrank parts that protrude through an aircraft structure and into the airstream. To form one of these parts, make a forming block of hardwood, hollowed out to the shape of the finished cover. The inside of the depression should be exactly the size and shape as the outside of the cover. Make a hold-down plate of metal or heavy plywood that will hold the edges of the metal, yet allow a mallet to be used to bump the metal on the inside of the form. [Figure 2-142]

Cut a sheet of annealed material, usually 3003-O or 5052-O aluminum, large enough to form the part. Clamp the metal between the forming block and the hold-down plate tight enough to prevent it from wrinkling, yet loose enough that it can slip as the

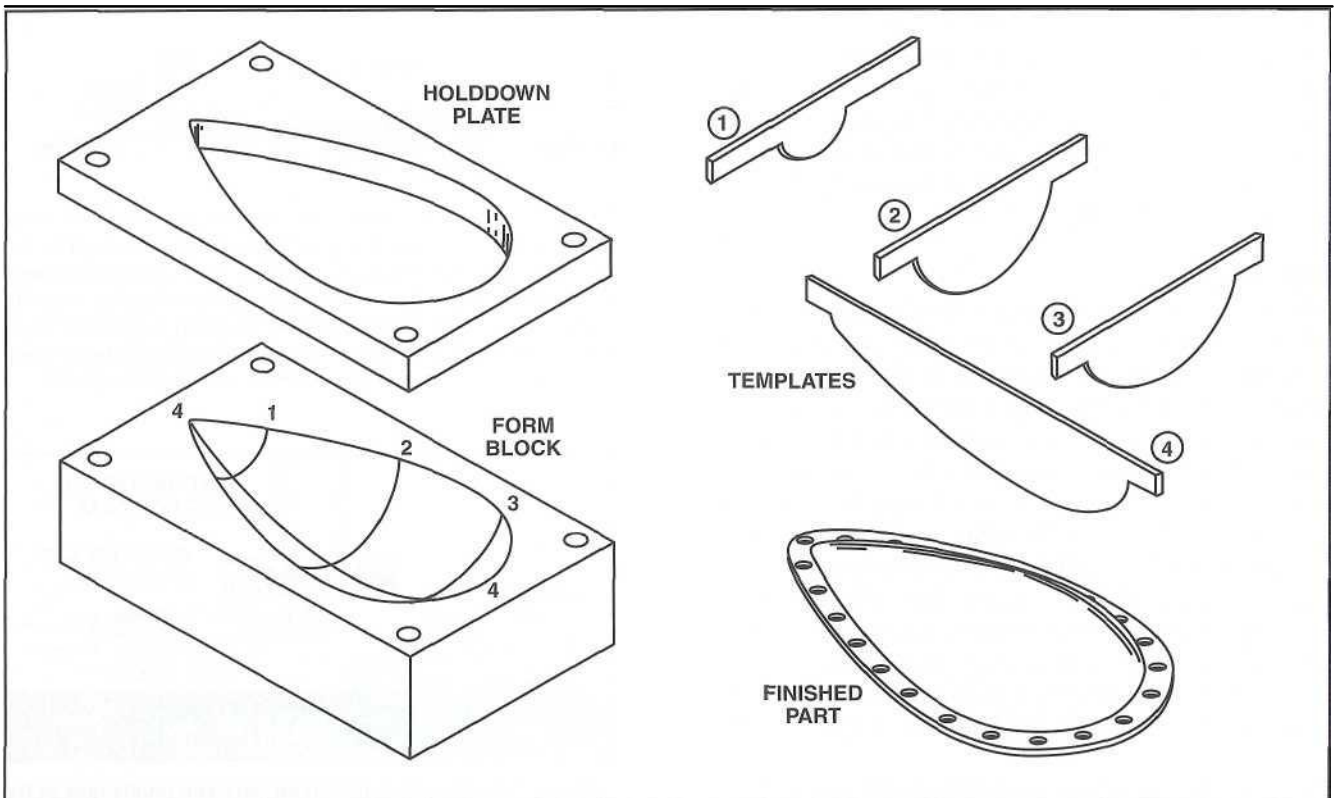

Figure 2-142. A female forming block allows compound curved parts to be made by bumping.

material is forced down into the depression. Begin forming by striking around the edges of the depression with a wedge-shaped plastic mallet. Stretch the material slowly and evenly as it goes into the depression.

In the process of forming deep parts, the material usually work-hardens and becomes difficult to form. When this happens, remove the material and anneal it. It should be annealed in a furnace, but if one is not available, and if the part is strictly non-structural, a rather rough procedure can be followed that will soften the material enough to finish bumping it to shape.

To perform this annealing process, remove the material from the forming block, and use a welding torch to coat it with a thin layer of carbon by using an extremely rich acetylene flame from a large tip. Then, using a large but very soft neutral flame, carefully heat the metal just enough to burn the carbon off. When the part cools, put it back between the forming block and the hold-down plate and finish bumping it into shape.

FLANGING LIGHTENING HOLES

The thin metal from which aircraft are made usually has ample strength, but its basic structural limitation

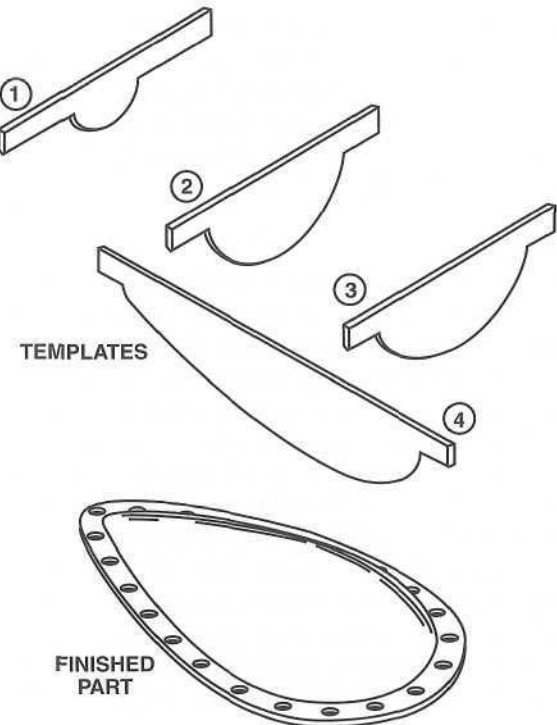

Figure 2-143. Using male and female flanging dies can stiffen the edges of a lightening hole.

lies in its lack of stiffness and rigidity. Two benefits can be gained, when making pieces such as fuselage bulkheads and wing ribs, by removing some of the metal to decrease weight and flanging the edge of the cutout to increase the rigidity of the part. These flanged cutouts are called lightening holes.

When a large number of lightening holes are to be cut, it is economical to make or purchase a two-piece flanging die made of steel. These dies are usually made in various sizes ranging from 1/2 inch to 6 inch diameters. [Figure 2-143]

To use lightening hole flanging dies, cut the proper size hole in the component with a punch press, hole saw, or fly cutter. Deburr the edges to be sure there are no rough spots that could cause the material to tear when it is stretched. Slip the male die through

the hole in the metal and position it over the female die. Once the dies are secured, put the assembly in an arbor press and press the male die into the female die. This forms the metal smoothly and uniformly without work-hardening. When the part is removed, very little finishing is required, making the process fairly quick and easy.

JOGGLING

When a sheet metal structure is built up, there are often locations where the metal is stacked into multiple layers where the parts are joined together. In order for the sheet metal pieces to be flat against the skin and yet have one on top of the other at the joining intersection, a process known as joggling is used. In joggling, the end of one of the pieces is bent up just enough to clear the other, and then it is bent back so it will be parallel to the original piece. Parts should be joggled to fit, rather than attempting to pull them into position with rivets. These joggles may be fabricated by pounding with a soft hammer against a block of wood, or they may be formed in a hydraulic press or with joggling dies. [Figure 2-144]

Joggling dies are often used when many parts are to be joggled with the same dimensions. If dies are not available, joggles may also be formed by stacking sheet metal in a similar fashion to that shown in Figure 2-145, and forming the joggle in a hydraulic or arbor press. [Figure 2-145]

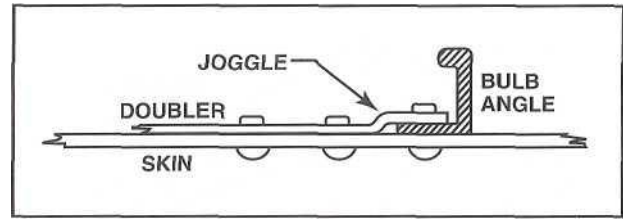

Figure 2-144. Joggles are used primarily to place parts on the same plane so there are no contours in the metal where the parts overlap. One example is where a doubler must fit over a bulb angle. Rather than attempting to pull the doubler against the skin with rivets, a joggle should be formed to allow the two metal pieces to be on the same plane.

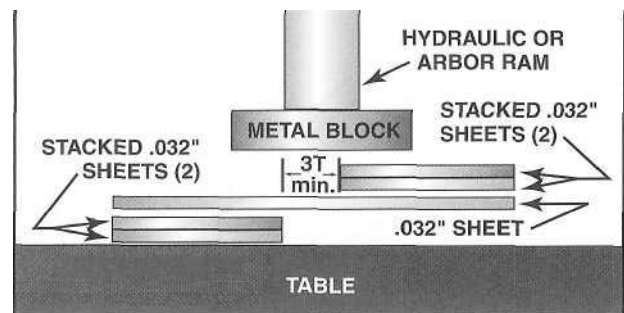

Figure 2-145. Clamping the metal between joggle dies or by placing metal sheets in position and applying force with a press can form joggles. When positioning the metal to form a joggle in this manner, it is important to leave enough distance between the sheets to prevent the bends from exceeding the minimum bend radius of the material being joggled.

INSPECTION AND REPAIR OF METALLIC AIRCRAFT STRUCTURES

SECTION D

Whenever sheet metal repairs become necessary, it is important to do a thorough inspection for damage that is not immediately apparent. For example, damage that is initially thought to be just a skin repair can have further damage to the underlying structure. Although a visual inspection can usually disclose damaged parts, distortion is occasionally difficult to detect by merely looking at the parts. In these situations, it is advisable for the technician to feel for deformation, such as wrinkles and buckling, by running a hand across the material. In other cases, it may be necessary to make measurements of the aircraft structure to assure symmetry between components when the damage is gradual over a large area. In addition, although inspecting for corrosion should be an on-going process, a more thorough inspection for corrosion can be accomplished whenever skins are removed for repairs.

REPAIR OF SHEET METAL STRUCTURES

The most important part of any repair to a sheet metal structure is to restore the integrity and strength of the component. If a repair procedure is not covered in a structural repair manual, the technician must use various tables to determine the number and sizes of rivets, as well as the best method for restoring the original quality of the structure.

REPAIRABILITY OF SHEET METAL STRUCTURES

Not too many years ago, major sheet metal repairs were done in most aircraft maintenance shops. However, today, with the high cost of labor, most repairs consist of removing the damaged component and replacing it with a new part from the factory. The complex construction and design of many newer sheet metal parts require forming methods beyond the economical capability of most smaller shops.

Major repairs to stressed skin aircraft should never be attempted unless the proper jigs are available to hold the structure in place when the skins are

removed. The manufacturer of the aircraft can normally furnish drawings that locate the critical jig points so the jigs can be made accurately. Also, in some cases, prefabricated jigs may be available from the manufacturer for lease. Examples of components that may need to be assembled in jigs include the fuselage, wings, doors, control surfaces, and flaps.

One of the big advantages of sheet metal construction over the formerly used welded steel structures is the ease with which it can be repaired. If, for example, there is major damage to the aft section of a fuselage, the rivets that hold the damaged area can be drilled out and the entire section removed. A new section can then be mated to the undamaged portion in a jig, and with a minimum of man-hours, the aircraft can be restored to its original condition and structural integrity.

ASSESSMENT OF DAMAGE

The difference between making a profit and losing money on a repair job is largely in the assessment of the damage. An intelligent bid must be made, one that includes the repair of every bit of the damage, yet one that is not so large that it disqualifies the bid. Damage that is visible from the surface is usually easy to evaluate, but it is the damage that is not readily apparent that can make the difference between profit and loss.

When examining a damaged structure, use the illustrated parts catalog to determine what types of components are not visible. Consider every piece of skin, rib, former, stringer, and fitting. Some of these parts which have only superficial damage may be quickly repaired, but once the labor of a repair is considered, it may be more economical to use new parts on larger or severely damaged components.

It may also be more economical to exchange a damaged component such as a wing or fuselage from a repair station that specializes in rebuilding these components. A repair station's specialized skills and equipment will allow it to make the repair with

a far smaller labor cost than a shop that does the work only occasionally. By exchanging for a component that has already been repaired, the damaged aircraft can be returned to service in far less time than if the work is done in a smaller, less specialized facility.

INSPECTION OF RIVETED JOINTS

Hidden damage may extend beyond the area of visible deformation, and any riveted joint that shows an indication of damage should be inspected well beyond the last deformed rivet. When inspecting the rivets, check both the manufactured heads and the shop heads.

One method of determining if the rivet has been tipped from excessive loads is to try slipping a .020-inch feeler gauge under the rivet head. If it goes under, the rivet may have been stretched. When rivet damage is suspected, drill out the rivet and examine the hole for any indication of elongation or tearing. If the structure has been damaged, the skin will shift when the rivet is taken out. All of the stresses caused by the stretching will have to be removed by drilling out rivets in the seam until there is no more shifting. If the holes are sufficiently out of alignment to require the next size larger rivet, be sure that the edge distance and rivet spacing will allow the use of the larger rivet. Otherwise, the skin will have to be replaced.

INSPECTION FOR CORROSION

Many times, aircraft structures that are enclosed will develop corrosion that will not be detected unless the structure is opened for repair. Also, if a damaged component is improperly stored for a long period of time, corrosion may develop. One of the most important aspects of sheet metal repair is to detect, remove, and treat corroded structural components before the corrosion has a chance to progress too far. If corrosion is found, every trace must be removed and the metal treated to prevent its recurrence. After the treatment, the part should be primed with either epoxy or zinc chromate primer. A more complete coverage of the removal and control of corrosion is found in Chapter Twelve of the *AfrP Technician General Textbook*.

REPAIR OF NEGLIGIBLE DAMAGE

Smooth dents in a structure, free from cracks and sharp corners that do not interfere with any structure or mechanism, are considered negligible damage. These may be left as they are, or, if the structure is painted, they may be filled with a resin-type filler, filed smooth, and refinished to match the rest of the

surface. However, fillers should not be used on control surfaces, because if the filler becomes dislodged, a severe imbalance could cause aerodynamic fluttering of the control. In fact, most repairs to control surfaces are classified as major because of the critical balance considerations.

Other forms of damage that may be considered negligible include scratches in aluminum alloy skins. However, scratches may harbor corrosion and concentrate stresses enough that they may cause the part to crack. If the scratch is not too deep, it can be burnished with a smooth, rounded piece of steel to force the metal back into the scratch. Work the metal back in smoothly and evenly, but do not allow it to lap or fold over and form an inclusion that will trap moisture and cause corrosion. [Figure 2-146]

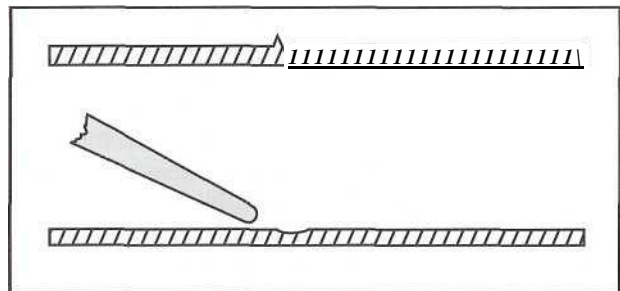

Figure 2-146. A scratch in a piece of aluminum may be burnished. The displaced metal is moved back into the scratch to prevent corrosion from forming. In addition, the blending of the metal reduces the possibility of cracks forming at the bottom of a scratch.

SPECIFIC SHEET METAL REPAIRS

Before discussing any type of specific repairs that could be made on an aircraft, remember that the methods, procedures, and materials mentioned in the following pages are only typical and should not be used as the authority for the repair. When repairing a damaged component or part, consult the applicable section of the manufacturer's **Structural Repair Manual (SRM)** for the aircraft. These manuals may also be referred to by some manufacturers as **Structural Inspection and Repair Manuals (SIRM)**, and essentially contain the same type of information as an SRM.

An SRM differs from the manufacturer's service or repair manual in that it is devoted entirely to the inspection and repair of the aircraft structure. On some smaller aircraft, the manufacturer will include a chapter on structural repair in the service manual rather than in a separate, dedicated SRM. Some of the areas covered in a structural repair manual (or a single chapter) will include the criteria that all

repairs must restore a damaged aircraft to its original design strength, shape and alignment.

Specific areas of repair and adjustment will usually include the equipment and tools necessary for repair, control balancing, and setting of the angle of incidence of the wings or stabilizers. Also included will be specifications for materials to be used and the procedures to follow in the repair of the fuselage, wings, ailerons, fin, stabilizer, elevator, rudder, engine mounts, baffling, and cowling. Instructions for all types of materials used in the structure will be included. Normally, a similar repair will be illustrated, and the types of material, rivets and rivet spacing, and the methods and procedures to be used, will be listed. Any special additional information needed to make a repair will also be detailed. If in doubt about any part of a repair detailed in the SRM, the aircraft manufacturer should be consulted.

REPAIR OF STRESSED SKIN STRUCTURE

When repairing damage to a stressed skin structure, it is important to make a repair which fully restores the original strength of the panel. The repair will be required to assume any loads transferred to it and pass them through to the rest of the structure.

APPROVAL OF REPAIRS

For an aircraft to remain legally airworthy, it must continue to meet all of the requirements for its original certification. This means that any repair must retain all of the strength, rigidity, and airflow characteristics of the original structure, and it must be protected against damage from the environment in the same way as the original, or better. Any repair that affects any of these factors must be approved by the FAA. The easiest way of assuring that the repair will meet the required standards is to verify that all data used is FAA approved.

Approved data may be in the form of the repairs that are described by the aircraft manufacturer's service manuals or structural repair manuals, which are usually FAA approved. Before using the manufacturer's repair information, check to see that there is a statement in the manual that designates the manual is FAA approved. Approved data can also be in the form of an Airworthiness Directive, or a Supplemental Type Certificate. If the repair is unusual, the aircraft manufacturer's engineering department may need to be consulted to obtain the instructions on how to perform the repair.

When a repair is made according to approved data, the aircraft can be approved for return to service by

an A&P technician holding an Inspection Authorization (IA). An IA must examine the repair to make certain it conforms to the approved data and then sign a statement of conformity on an FAA Form 337. Once the IA signs the 337 Form and other appropriate maintenance record entries are made, the aircraft can be returned to service.

If the repair cannot be made in accordance with approved data, a technician can detail the methods that will be used to conduct the repair on a 337 Form and submit the information for approval from the FAA. It is important that the repair procedure receive approval prior to any work being accomplished on the aircraft. In most cases, the 337 Form can be submitted to the local Flight Standards District Office for approval. However, if the repair is extensive, the local office submits the information to the engineers in the aircraft certification department for approval.

When detailing the methods that will be used to conduct a repair, information to substantiate that the procedure meets FAA criteria can come from a number of sources. One source that is commonly used is to reference procedures outlined in Advisory Circular AC 43.13-1B, *Acceptable Methods, Techniques, and Practices*. However, the information contained in this circular is not FAA approved, but is considered acceptable to be used to meet airworthiness standards. Once the AC is used as a reference, the FAA must verify that the information meets approved criteria.

Upon completion of the repair, in most cases, an IA can perform an inspection to verify that the work has been done in accordance with the approved procedures, and then permit the aircraft to be returned to service.

If a similar repair has been made on another aircraft and written up on a 337 Form and approved, that 337 Form may not be used as approved data because its approval is for a one-time-only specific repair. A similar repair can be made, but the repaired aircraft will have to be approved for return to service by the FAA via another 337 Form.

CRITERIA OF A REPAIR

Any repair made on an aircraft structure must allow all of the stresses to enter, must sustain these stresses, and must then allow them to return into the structure. The repair must be as strong as the original structure, but not different enough in strength or stiffness to cause stress concentrations or alter the resonant frequency of the structure.

All-metal aircraft are made of very thin sheet metal, and it is possible to restore the strength of a repair without restoring its rigidity. All repairs should be made using the same type and thickness of material that was used in the original structure. If the original skin had corrugations or flanges for rigidity, these must be preserved and strengthened. If a flange or corrugation is dented or cracked, the material loses much of its rigidity and must be repaired in such a way that will restore its rigidity and stiffness as well as its strength.

There also must be no abrupt changes in the cross-sectional area of a repair. If a crack is reinforced in a stressed skin, it should not be made with a rectangular patch that causes an abrupt change in the strength of the skin, as the stresses enter, and then another abrupt change as they leave. Rather, use an octagonal patch that gives a more gradual change as the stresses enter and leave the repair area. [Figure 2-147]

Think ahead when considering a repair. Remember that every rivet that is removed must be reinstalled, and to drive a solid rivet, access must be made to both the manufactured head and the shop head. If there are areas that cannot be reached to buck a solid rivet, it may be necessary to use blind rivets. A friction-lock Cherry rivet usually requires one size larger diameter than a solid rivet it replaces, and if one is used, be sure to verify that sufficient edge distance exists. On the other hand, a mechanical-lock Cherry rivet normally allows the use of the same size diameter as the solid rivet it replaces and also may be available in slightly oversized diameters.

Both Hi-Shear rivets and Huck Lockbolts are types of high-strength pin rivets that are used in aircraft factories for applications where high strength is needed, but where light weight and ease of installation make them a preferred choice over bolts and nuts. If one of these special fasteners need to be replaced in a repair and the proper tooling is not available, bolts and self-locking nuts are generally allowed as replacement hardware. However, it is still necessary to verify that the aircraft manufacturer allows the substitution.

REPLACEMENT OF A PANEL

In accordance with FAR Part 43, Appendix A, if additional seams are cut in a stressed skin panel, these types of repairs constitute a major repair, and must have FAA approval before the aircraft can be approved for return to service. In addition, repairs to stressed skin panels that exceed 6 inches in any direction also constitute a major repair, and also

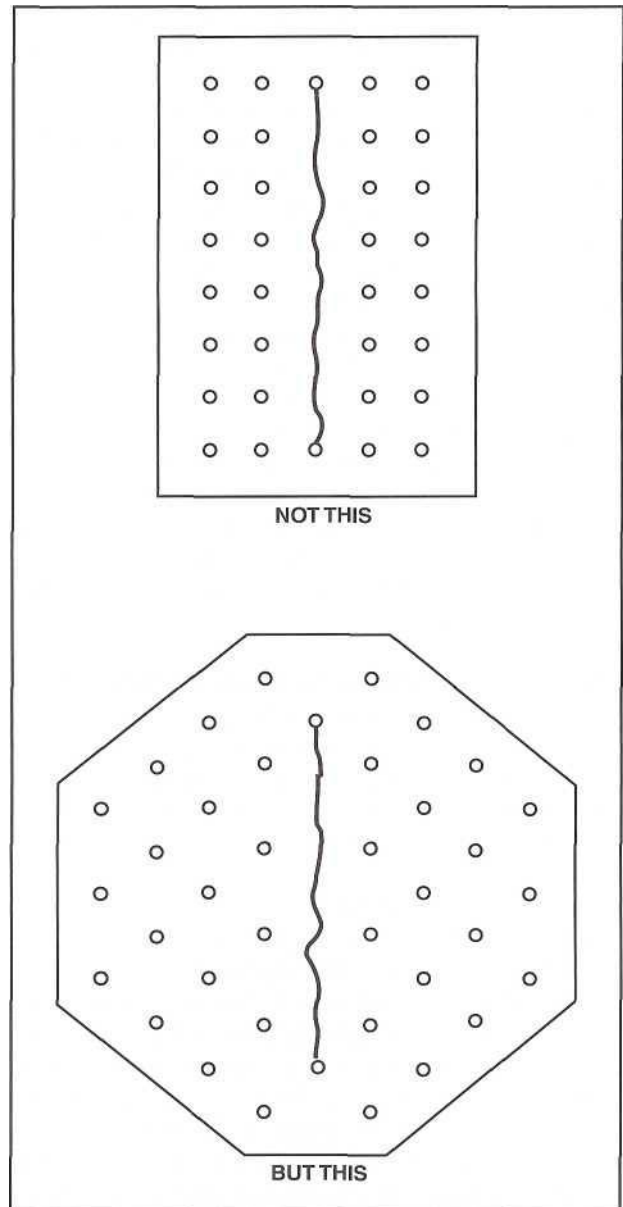

Figure 2-147. A repair should be constructed to allow the stresses to be imparted on the repair area in a gradual manner. Increasing the cross section of a repair over a wider area helps reduce the stress concentrations caused by an abrupt change.

must have FAA approval. On the other hand, if a skin on a wing or tail surface has been extensively damaged, it may be more economical to replace an entire panel rather than making a repair within the panel.

To perform these repairs, remove the damaged panel from one structural member to the next, cutting a generous radius in all of the corners. Usually a radius of 1/2 inch is considered to be the minimum size. Remove all of the rivets immediately sur-

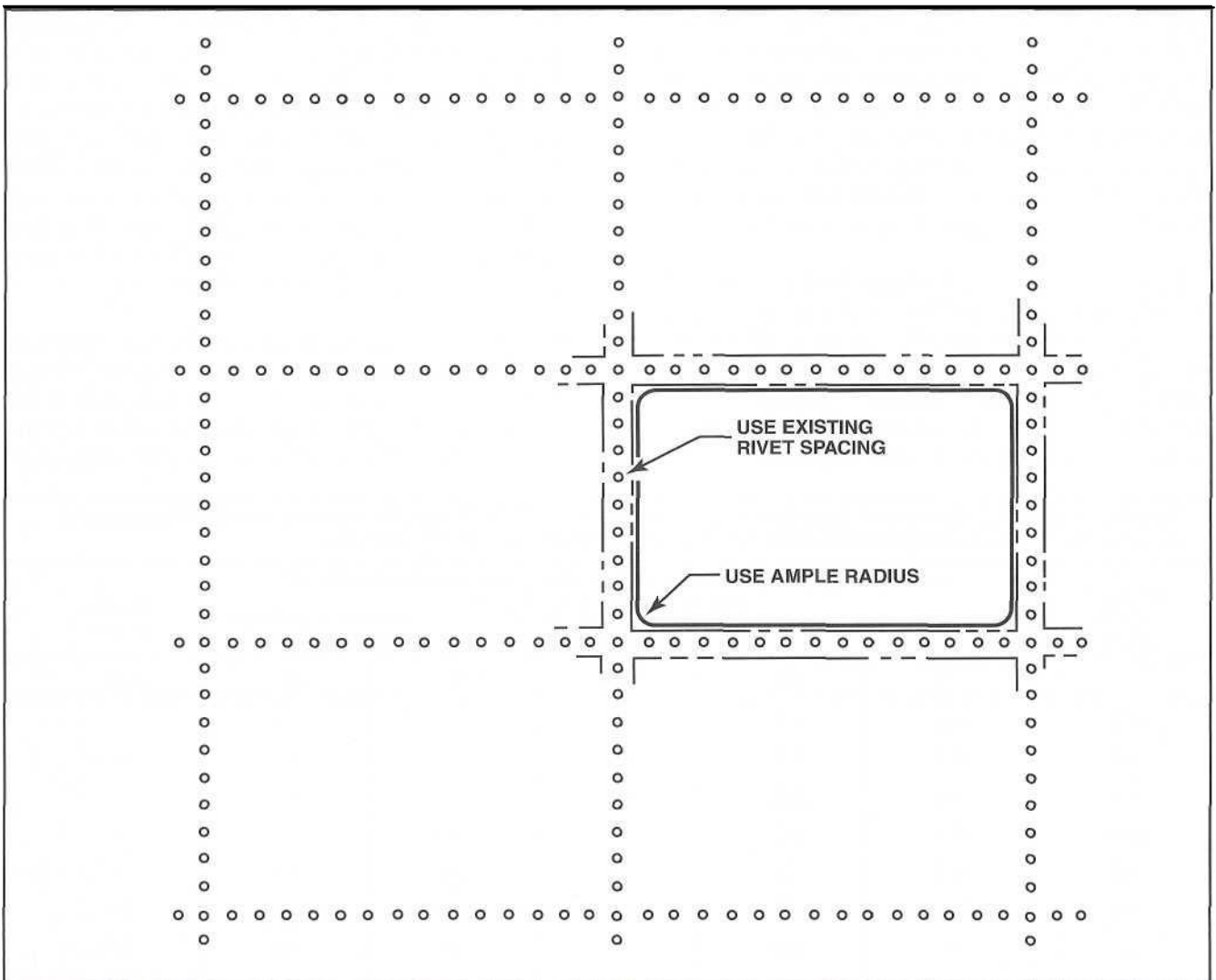

Figure 2-148. It is often advisable to replace an entire panel rather than making a patch within the panel.

rounding the cutout. When installing the new panel, use the same rivet size and spacing as was used on the original structure, unless there is different rivet spacing along a sheet splice for the panel being repaired. If different rivet spacing is used, apply the same spacing as was used on the splice inboard or ahead of the panel being replaced. Be sure when cutting the new panel that sufficient edge distance exists for all of the rivets to be installed. [Figure 2-148]

Cut the panel to size and drill one of the corner rivet holes. Fasten the panel to the structure with a Cleco fastener, aligning the panel with the structure. Now, using a hole finder, locate and drill the other corner holes and temporarily fasten these holes with Cleco fasteners. If possible, back-drill the rest of the holes through the structure or, if not possible, use the hole

finder to locate the remaining holes. Then remove the panel and deburr all of the holes and the corners of the panel. Finish the panel by gently crimping the edges so it will fit tightly against the skin, and spray the inside with a light coat of zinc chromate primer. Once the panel is prepared, fasten it back in position with Cleco fasteners, and begin riveting the panel in place.

DESIGN OF PATCHES FOR STRESSED SKIN

When there is damage to a stressed skin, first determine the amount of strength that has been lost, and then design a patch that will restore the strength. A typical example of this kind of repair restores the original strength by placing an octagonal patch over a crack. For example, assume a repair is needed to a .040-inch aluminum alloy skin with a 2-inch crack across the material.

To begin the process of repairing the panel, begin by finding out how much strength the damaged section needs to provide. To determine this value, tables are available that specify the number of rivets that are necessary to impart the same strength through the repair as through an undamaged sheet of aluminum. These tables specify a particular type and size of rivet in various thickness aluminum alloy sheets.

Using one such table for 1/8-inch diameter, 2117 AD rivets in .040 inch 2024-T3 skin, 7.7 rivets per inch of crack width are called for on each side of the damaged area. This falls below the line in this column, which means that the joint is critical in shear, or that it will fail by the rivets shearing rather than by the sheet tearing at the holes. [Figure 2-149]

Begin the repair by drilling a number 30 stop-drill hole in each end of the crack. Clean a piece of .040-inch aluminum alloy with lacquer thinner and spray it with a light coat of zinc chromate primer so the layout lines will show up. Start the layout with the locations of the stop-drill holes, and draw a line between them. Now, draw a parallel line on each side of this line, two and one-half rivet diameters from it. This is the edge distance between the center of the rivet hole and the edge of the crack.

Since the damage to the skin is 2 inches, there will need to be a minimum of 16 rivets on each side of the repair. However, 16 rivets on either side of the crack will not allow a symmetrical patch. On the other hand, if 18 rivets are used on each side, a pat-

Table 4-9. Number of rivets required for splices (single-lap joint) in bare 2014-T6, 2024-T3, 2024-T36, and 7075-T6 sheet, clad 2014-T6, 2024-T3, 2024-T36 and 7075-T6 plate, bar, rod, tube, and extrusions, 2014-T6 extrusions.						
Thickness "t" in inches	No. of 2117-T4 (AD) protruding head rivets required per inch of width "W" (on each side of crack or splice)					No. of Bolts
	Rivet Size					
	3/32	1/8	5/32	3/16	1/4	AN-3
.016	<u>6.5</u>	4.9	--	--	--	--
.020	6.9	4.9	3.9	--	--	--
.025	8.6	<u>4.9</u>	3.9	--	--	--
.036	11.1	6.2	<u>3.9</u>	3.3	--	--
.036	12.5	7.0	4.5	<u>3.3</u>	2.4	--
.040	13.8	7.7	5.0	3.5	<u>2.4</u>	3.3
.051	--	9.8	6.4	4.5	2.5	3.3
.064	--	12.3	8.1	5.6	3.1	3.3
.081	--	--	10.2	7.1	3.9	3.3
.091	--	--	11.4	7.9	4.4	<u>3.3</u>
.102	--	--	12.8	8.9	4.9	3.4
.128	--	--	--	11.2	6.2	3.2

NOTES:

- For stringers in the upper surface of a wing, or in a fuselage, 80 percent of the number of rivets shown in the table may be used.
- For intermediate frames, 60 percent of the number shown may be used.
- For single lap sheet joints, 75 percent of the number shown may be used.

ENGINEERING NOTES:

- The load per inch of width of material was calculated by using a strip 1 inch wide in tension.
- Number of rivets required was calculated for 2117-T4 (AD) rivets, based on a rivet allowable shear stress equal to 40 percent of the sheet allowable tensile stress, and a sheet allowable bearing stress equal to 160 percent of the sheet allowable tensile stress, using nominal bolt diameters for rivets.
- Combinations of sheet thickness and rivet size above the underlined numbers are critical in (i.e., will fail by) bearing on the sheet; those below are critical in shearing of the rivets.
- The number of AN-3 bolts required below the underlined number was calculated based on a sheet allowable tensile stress of 70,000 psi and a bolt allowable single shear load of 2,126 pounds.

Figure 2-149. Tables are available that specify the number of rivets required for each side of a single lap joint repair to restore the original strength to sheet aluminum.

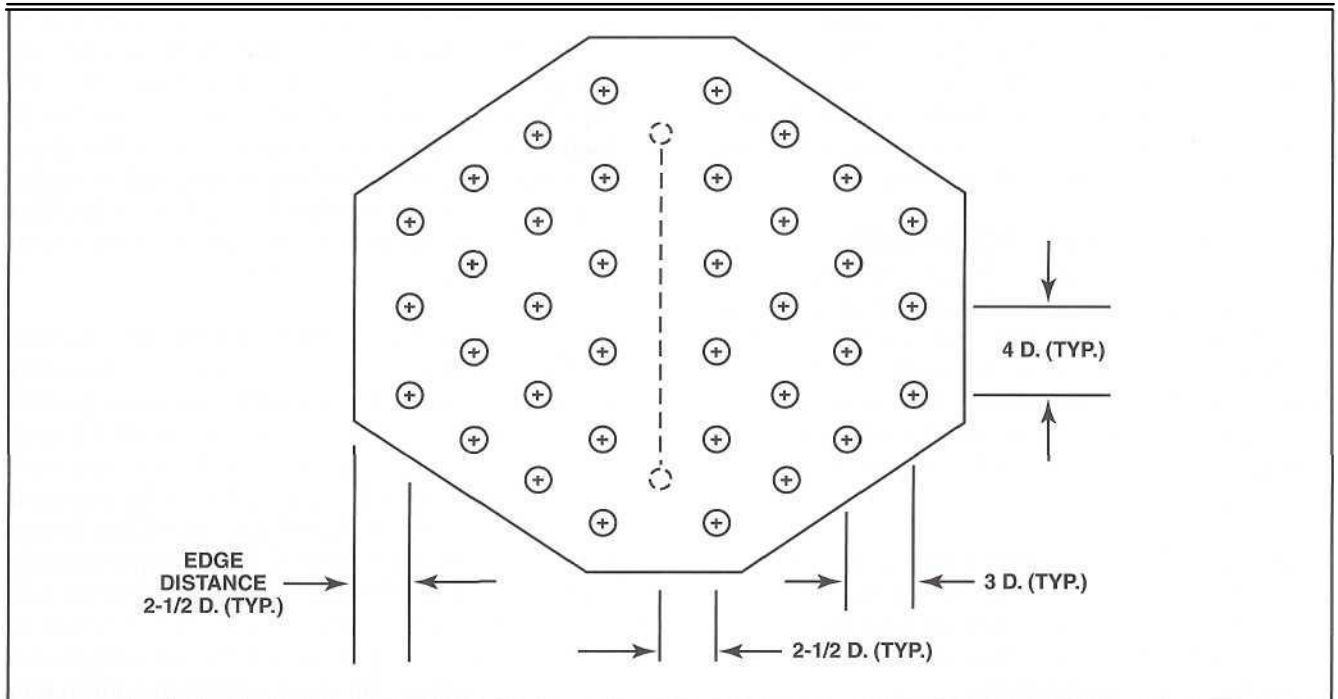

Figure 2-150. This layout of an octagonal patch shows the pattern and number of required rivets to repair a 2-inch crack in stressed .040-inch thick 2024-T3 aluminum alloy skin.

tern can be formed consisting of seven rivets in the first row, six in the second, and five in a third row. Although the pattern will use more than the minimum number of rivets, this is allowed. The determining factor for the maximum number of rivets is that the rivets cannot be spaced closer together than minimums allow, while also maintaining edge distances. By using four rivet diameters for the pitch, a rivet spacing of 1/2-inch can be used and the correct distance between the rows will be 3/8-inch. [Figure 2-150]

Use a fine tipped marker to lay out all the lines and mark the 36 rivet holes. Draw a line, two and one-half diameters from the center of the rivets in the outside rows. Cut the patch along this outside line, deburr all of the edges, and cut a radius in all of the corners. Center punch each rivet location, and drill a number 30 hole for each rivet. Once drilled, deburr each of the holes.

After the patch has been prepared, center it over the stop-drilled crack and drill two holes through the skin to match the holes in diagonal corners of the patch. If the damage is on a curved portion of the skin, the patch will first need to be run through a slip roll former to form its contour to match the skin. Do not try to form the metal by holding the patch by hand while drilling. In most cases, the

amount of tension on the metal will cause it to slip. When the rivets are installed, the metal will shift, causing the drilled holes to misalign. The patch must fit smooth and tightly before riveting. Also, slightly crimping the perimeter of the patch prevents the edges from lifting. [Figure 2-151]

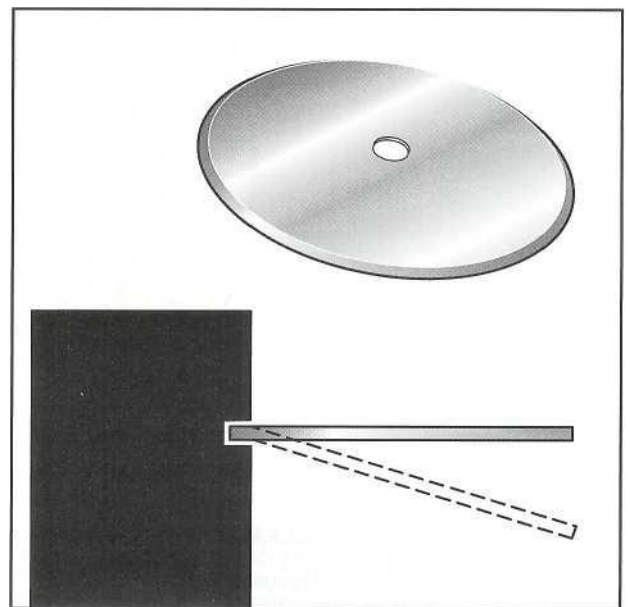

Figure 2-151. A simple tool for beveling the edges of a patch can be fabricated from a phenolic block. Using a band saw, notch the end of the block to the desired depth of the bevel.

Fasten the patch in place with Cleco fasteners and drill all of the remaining rivet holes. After drilling, remove the patch, deburr the holes in the skin, and remove any metal chips. Once deburred and cleaned, verify that the protective coating is in good condition and rivet the patch in place.

FLUSH PATCH STRESSED SKIN REPAIRS

Small damage in a stressed skin may be repaired by making a circular patch that has uniform strength in all directions. For maximum streamlining, a flush patch may be installed on the inside of the skin, using flush rivets, and a plug of the same thickness as the skin. The plug is riveted in the hole where the damaged skin is removed, and contours the surface to the original shape.

Designing a flush patch repair is similar to any other type of patch repair. For example, if there is damage to a .025-inch aluminum alloy stressed skin made from 2024-T3 material, a flush patch can be fabricated in the following fashion.

Before installing a patch, it is necessary to remove any damaged material. For this example, assume that a 2-inch hole has been cut to remove the damaged material. Begin designing the patch by deter-

mining the minimum number of rivets required to restore the strength of the sheet metal. By referring to the chart in figure 2-149, it is found that the repair requires 8.6 3/32-inch diameter rivets per inch on each side of the damage in a doubler plate. Although the material will be removed in a circular pattern, the damage still has a 2-inch diameter. This means that the repair must have at least 18 rivets on each side of the damage. [Figure 2-152]

Lay out the pattern on a piece of .025-inch material, making a circle with a 1-inch radius, representing the removed damage in the skin. Then draw a circle with a radius of 1.23 inches to locate the first row of rivet holes, which is approximately two and one-half rivet diameters from the edge of the removed damage. A second circle with a radius of 1.61 inches will locate the second row of rivets, approximately four diameters from the circle on which the first row is located. Finally, a third circle with a radius of 1.84 inches is marked to locate the outside perimeter of the doubler. This will provide the minimum edge distance from the outside row of rivets to the edge of the doubler.

Using a protractor, mark off 20 degree increments on the first circle to locate 9 rivets on each half of the

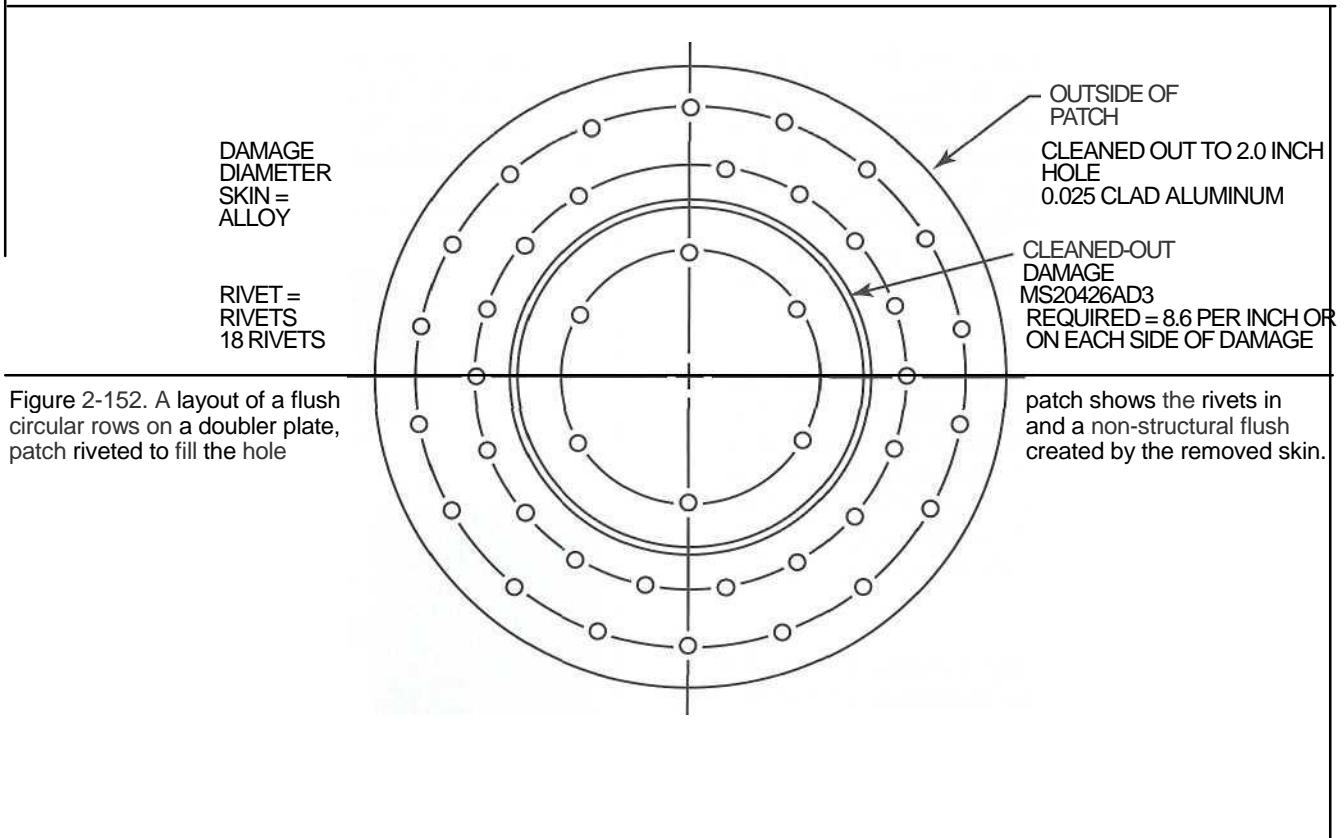

Figure 2-152. A layout of a flush circular rows on a doubler plate, patch riveted to fill the hole

patch shows the rivets in and a non-structural flush created by the removed skin.

circle. Now, mark between the center of each of these rivets on the second circle to locate the center of the rivets in the second row. Mark all of these locations, and then center punch them for drilling. Use a number 40 drill to make the rivet holes at each of the locations.

Once the doubler is fabricated, position it on the inside surface of the skin and center it under the cleaned-out damage. Drill one hole, and fasten the doubler in place with a Cleco fastener. Once one hole is fastened, continue to drill for the remaining rivets, securing the doubler with a sufficient number of Cleco fasteners as the drilling progresses.

Once the drilling is complete, remove the doubler, deburr all holes, and clean out any metal chips. Because the repair is to be flush, instead of using universal head rivets, flush head rivets will be installed. Since the skin has insufficient thickness to allow counter-sinking, the rivet holes must be dimpled to accept MS20426AD3 rivets. Once the doubler plate has been dimpled, spray the surface with zinc chromate primer and rivet it in place.

The final step in completing the repair involves cutting a circular patch of .025-inch material that will fill in the removed skin. Once fabricated, place the patch in the hole and drill for rivets through the patch and doubler. Since the patch does not offer any strength to the stressed skin, only enough rivets are required to hold the patch securely in place to prevent the edges from lifting. After the patch is prepared, dimple the metal, and finish installing the rivets.

STRINGER REPAIRS

The most critically loaded stringers in an aircraft structure are those found in the lower surface of a cantilever wing. They are under a tensile load in flight and under a compressive load upon landing. Stringers must receive the greatest amount of care when being repaired to enable them to withstand high stress loads.

When a bulbed stringer must be spliced, first determine the amount of material in the cross-section, and use material having the same or greater area to attach a doubler with the number of rivets specified in figure 2-149. For example, assume a stringer has a 1 inch wide flange on one side, and a 1/2-inch wide flange on the other, and is made of .040-inch 2024T-3 aluminum alloy. In this example, the stringer would have a total cross section of 1.5 inches. According to figure 2-149, there will need to be 7.7 rivets per inch of width, or 12-1/8-inch diameter rivets on each side of the splice (7.7 x 1.5). Putting an extra 3/32-inch diameter rivet at each end will help avoid an abrupt cross-sectional area change. Allowing for an edge distance of two and one-half rivet diameters, and a spacing of three diameters, the splice will have to extend 5.05 inches on either side of the joint. [Figure 2-153]

For splice material, use a piece of the same type of bulb angle. Taper the ends of the top flange back to provide a gradual change in the cross-sectional area and rivet the two pieces together. For formed stringers and extrusions other than bulb angles, the repair is similar. Form a reinforcement piece with

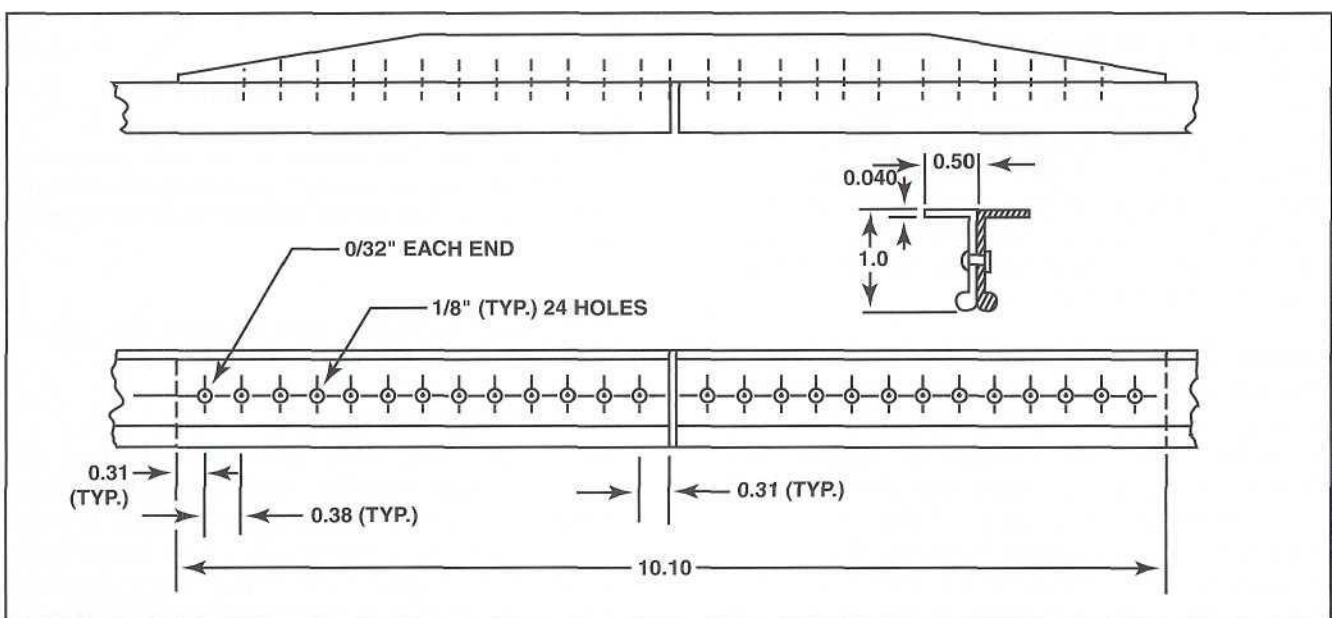

Figure 2-153. This layout shows the required number of rivets spaced out on each side of a stringer splice.

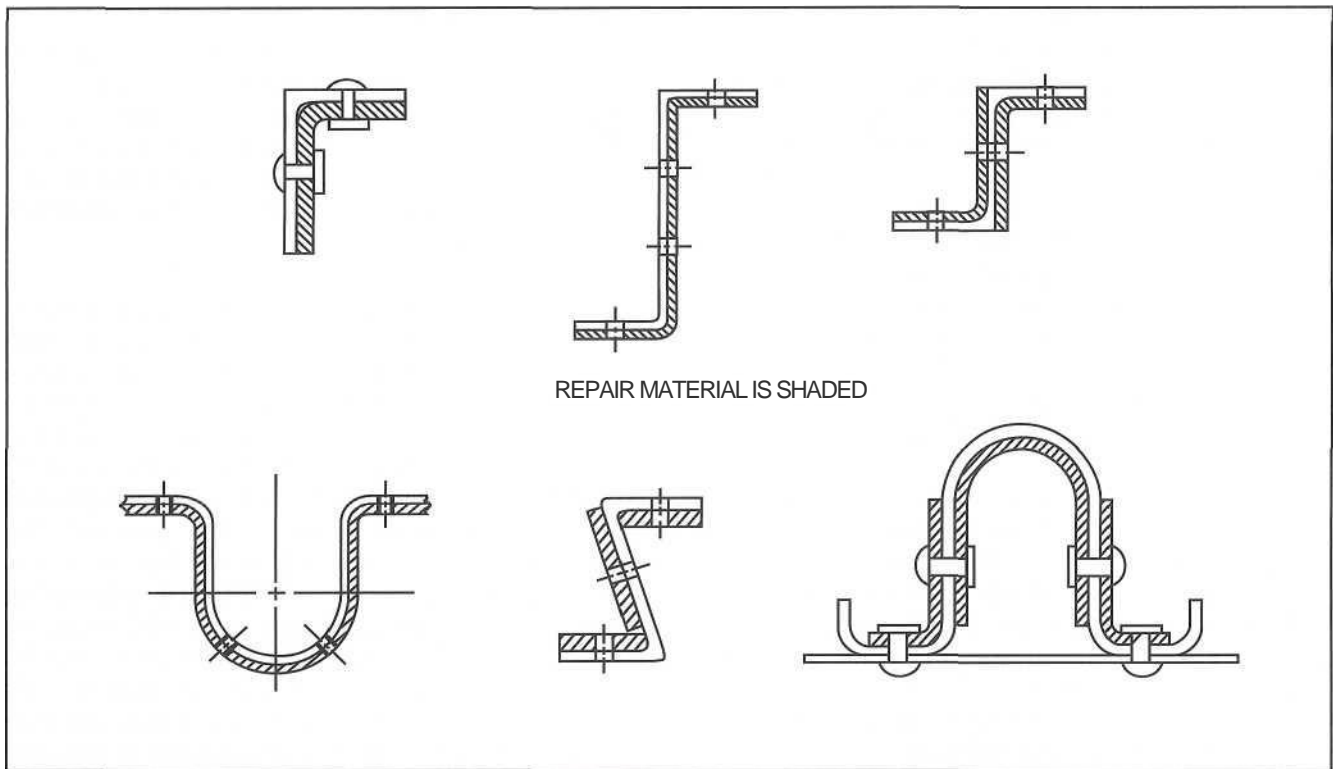

Figure 2-154. The cross-sectional area of the repair material must be greater than the damaged area. On a typical stringer repair, this requires reinforcing more than one angle of the stringer.

more cross-sectional area than the damaged stringer, and rivet it in place with the number of rivets specified in figure 2-149. Remember, the function of a stringer is to provide stiffness as well as strength. [Figure 2-154]

REPAIRS FOR WATERCRAFT

In addition to providing adequate strength with the proper streamlining, any repair to a float or boat hull must be waterproof, and adequately protected from corrosion. The strength requirements and layout procedures are similar to other repairs previously discussed, but when a patch is prepared, coat it with a rubber-like sealant, and then put in place. Also, dip all rivets in the sealant and install them while the sealant is wet.

TRAILING EDGE REPAIRS

The trailing edge of a truss-type wing is usually made of aluminum alloy formed into a V-section. When these areas are distorted or cracked, they should be straightened out as much as possible and an insert formed of the same thickness material, slipped inside and riveted in place. These rivets will be difficult to install, and will have to be put in with the manufactured head on the inside, and bucked with a bar ground to fit in the confines of the

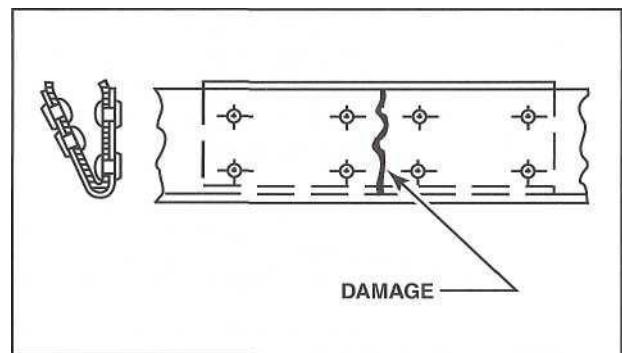

Figure 2-155. A typical trailing edge repair shows the repair material inserted into the inside of the angle and riveted in place.

V. The rivet shank can then be upset with a flush rivet set. [Figure 2-155]

CORRUGATED SKIN REPAIRS

The control surfaces on most light, all-metal airplanes are made from thin sheet metal, which is corrugated to give additional stiffness. When a corrugation is dented or cracked, it can no longer withstand the loads imposed on it, and must be repaired. To perform repairs to corrugated surfaces, remove the damaged area and rivet a new piece of skin in

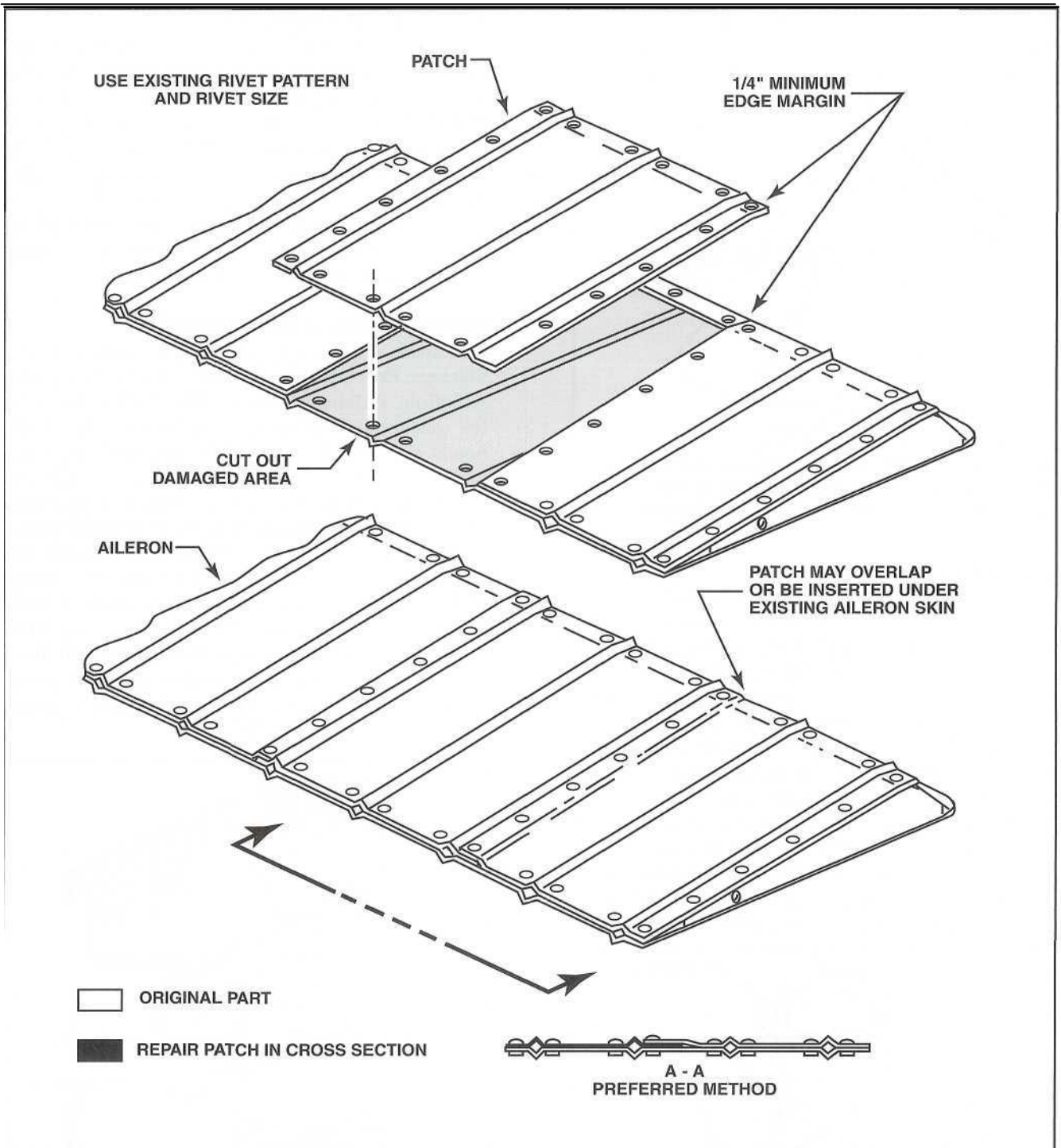

Figure 2-156. The most common repair to light aircraft control surfaces involves replacing a portion of the corrugated skin.

place. Corrugated skins are available from the aircraft manufacturer, or can be fabricated by forming in a press. [Figure 2-156]

It is extremely important when making any repair to a control surface that the repair does not add

weight behind the hinge line. In the SRM, the aircraft manufacturer generally specifies the balance conditions for the surfaces. After repairs have been made to a control surface, it must be checked to determine that its balance falls within specifications. In addition, any repair to monocoque or

semimonocoque control surfaces constitutes a major repair. [Figure 2-157]

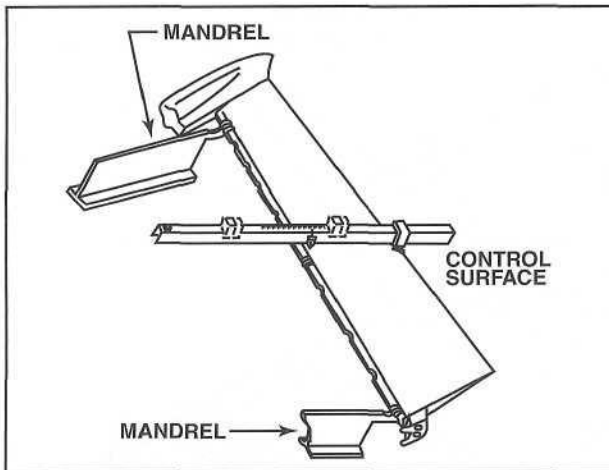

Figure 2-157. The static balance of control surfaces must be checked after a repair has been made to be sure that it is within the tolerances allowed by the manufacturer.

INSPECTION OPENINGS

Many times, a repair must be made to a metal structure that requires access to the inside where the manufacturer has provided no openings. In these situations, inspection hole kits are often available so holes can be cut wherever access is needed. These kits usually include doublers and plates for reinforcing and covering the access opening. Generally, the doubler is riveted to the inside of the structure, and screws are used to secure the cover. Be sure, before cutting a hole in the structure, that it is not located in a highly stressed area. If there is any doubt about the location of the hole, check with the manufacturer or obtain approval from the FAA before cutting a hole. [Figure 2-158]

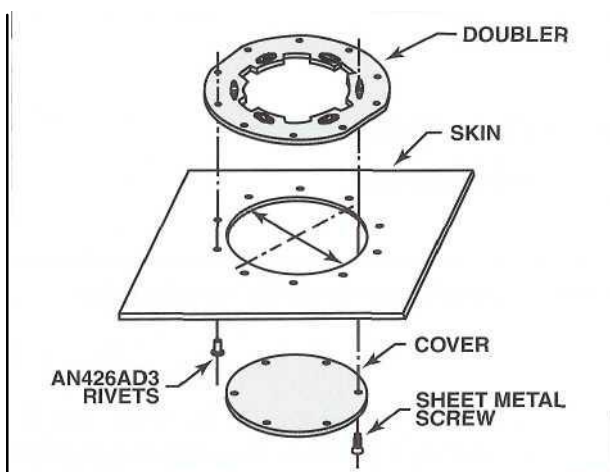

Figure 2-158. Inspection holes may be cut in an aircraft skin to allow access to an area that must be repaired. Be sure that the location for such a hole is approved before cutting the opening.

SPECIALIZED REPAIRS

The high stresses encountered by modern aircraft require that every repair to a structure be carefully considered and made only in accordance with data that is furnished by the manufacturer, or that is specifically approved by the FAA. This is especially true for major load carrying members such as bulkheads, formers, and spars. In addition, special considerations must be used when repairing pressurized aircraft because of the high stress loads encountered in the pressurized sections of the airframe.

FORMER AND BULKHEAD REPAIRS

Bulkheads are primary load carrying members of a fuselage. However, they are also found in wing construction. Bulkheads are usually perpendicular to the longerons, keel beams, or stringers. Some bulkheads also run fore and aft in the fuselage, especially around passenger and cargo doors. On the other hand, formers are often called forming rings, body frames, circumferential rings, or belt frames, because of the manner in which they provide the shape to a fuselage structure. Formers are usually riveted to longerons and stringers in order to carry primary structural loads. Since formers and bulkheads may be subject to high loads, repairs to these components should be conducted in strict accordance with the aircraft manufacturer's repair instructions. [Figure 2-159]

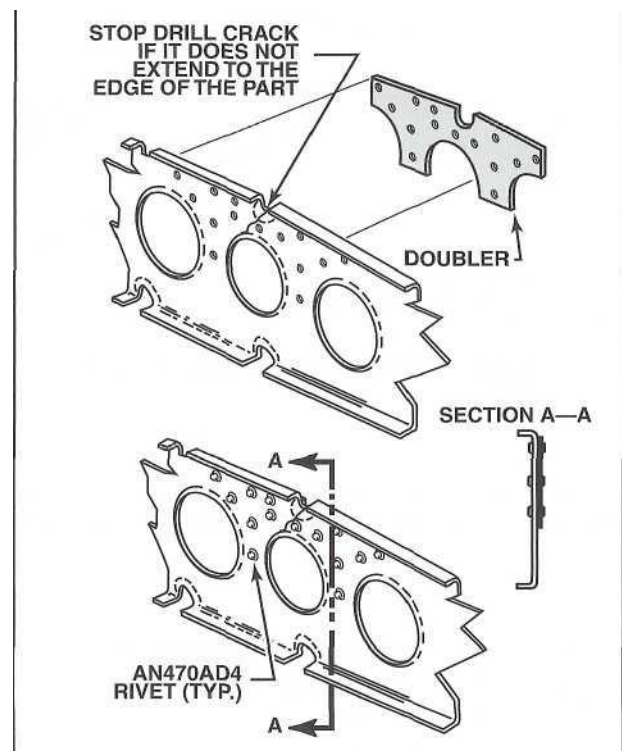

Figure 2-159. A wing rib or fuselage former must be reinforced with a doubler over the damaged area.

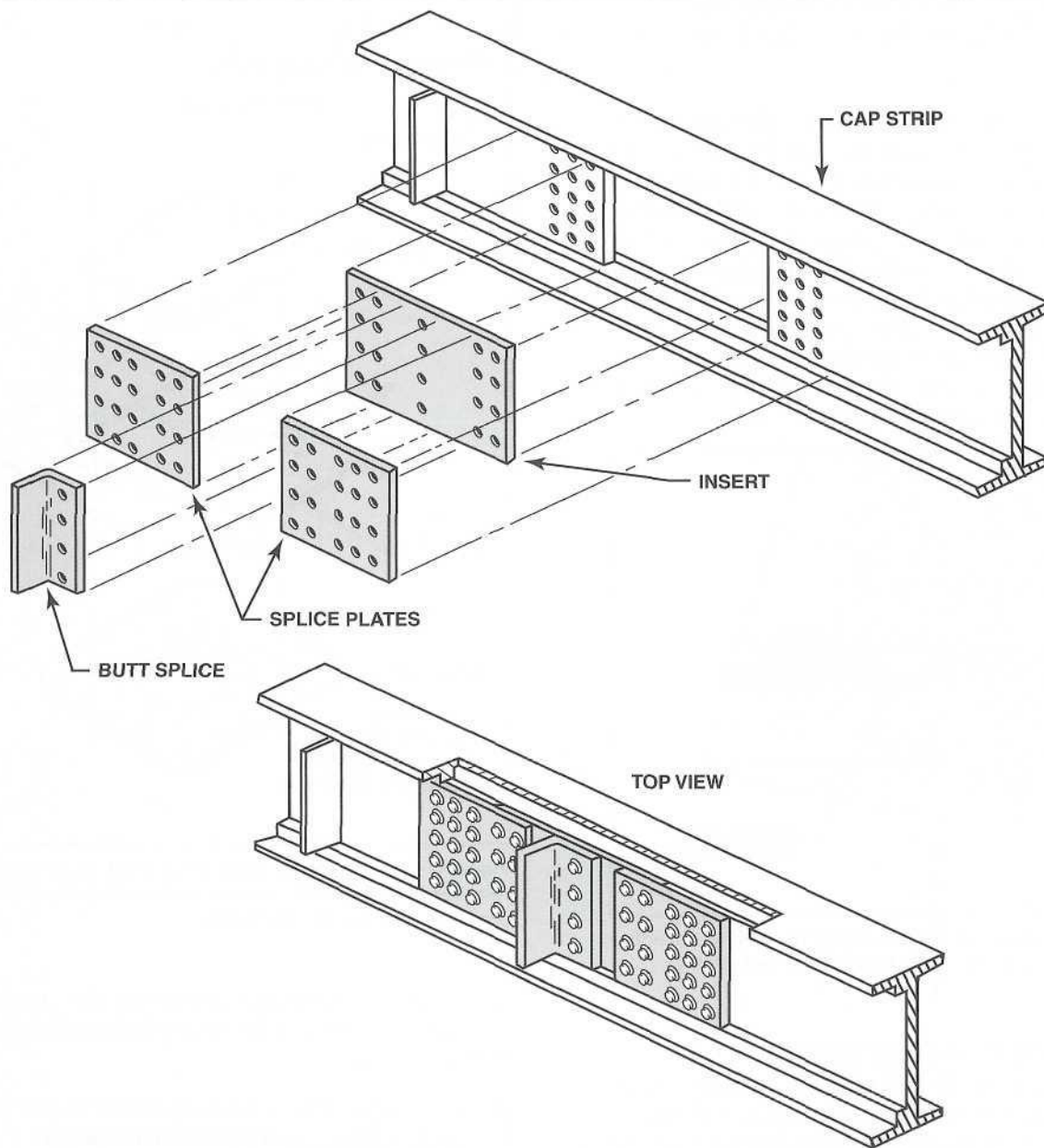

Figure 2-160. A spar web butt splice requires adding an insert to replace the cutout damaged area. Any material used for a splice should be of the same type and thickness as the original spar, and reinforced with doubler plates.

SPAR REPAIRS

The spar, being a primary load carrying member of the wings, usually requires repairs to be made according to the aircraft manufacturer's instructions. However, spar repairs of a general nature are also covered in AC43.13-1B, *Acceptable Methods, Techniques and Practices*. Again, these repairs are not approved for any specific aircraft, but the procedures may be used to obtain FAA approval.

Some spar repairs involve placing an insert in place of a damaged section. Before riveting the insert in

place, give all contacting surfaces a coat of zinc chromate primer. The rivets used for attaching the insert section to the spar flange are in addition to those calculated for attaching the splice plates. One typical spar repair is shown in Figure 2-160.

LEADING EDGE REPAIRS

A damaged leading edge usually involves nose ribs, skins and the spar. Repairs made to these components are usually outlined in the manufacturer's SRM or maintenance manual. Since the leading edges are laid out in sections from the wing butt to

the tip, the manufacturer often recommends that an entire leading edge section be replaced during the repair procedure.

One difficulty encountered when replacing a leading edge is trying to maintain the contour of the structure during installation. In many cases, it is advisable to use cargo straps or other similar devices to hold the leading edge in position before drilling any holes. Once the leading edge has been initially contoured and positioned, wrap the straps around the wing and tighten them to pull the leading edge into position. Once secured, it is less likely to have problems with the leading edge shifting, which causes misaligned rivet holes. [Figure 2-161]

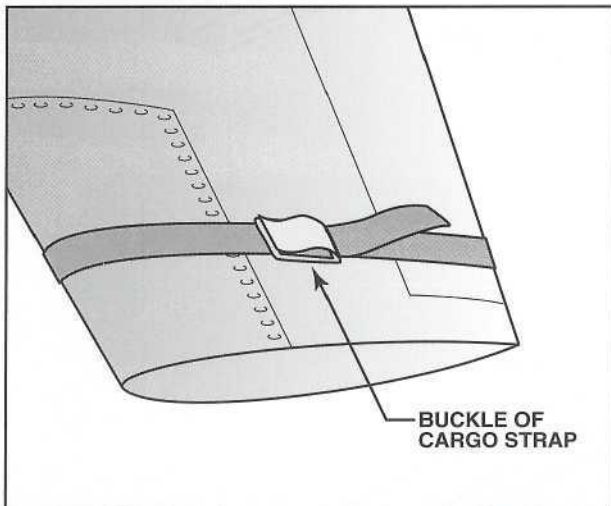

Figure 2-161. Cargo straps are useful for pulling a leading edge section into position before drilling and riveting.

PRESSURIZED STRUCTURE REPAIRS

High performance aircraft with pressurized cabins are becoming more common in aviation, and repairs to this type of structure must take into account the need for additional strength. The increased strength is especially critical due to the flexing of the structure during pressurization and depressurization cycles. When repairs are necessary on these aircraft, it is especially critical to follow the aircraft manufacturer's procedures. In many cases, the manufacturer's engineering department must design and issue specific instructions to be followed when conducting repairs to pressurized airframe structural components. [Figure 2-162]

MISCELLANEOUS REPAIRS

In many situations, it is possible that more than a single sheet metal component will suffer damage, making it necessary to use a combination of repair techniques. One such repair involves damage to the

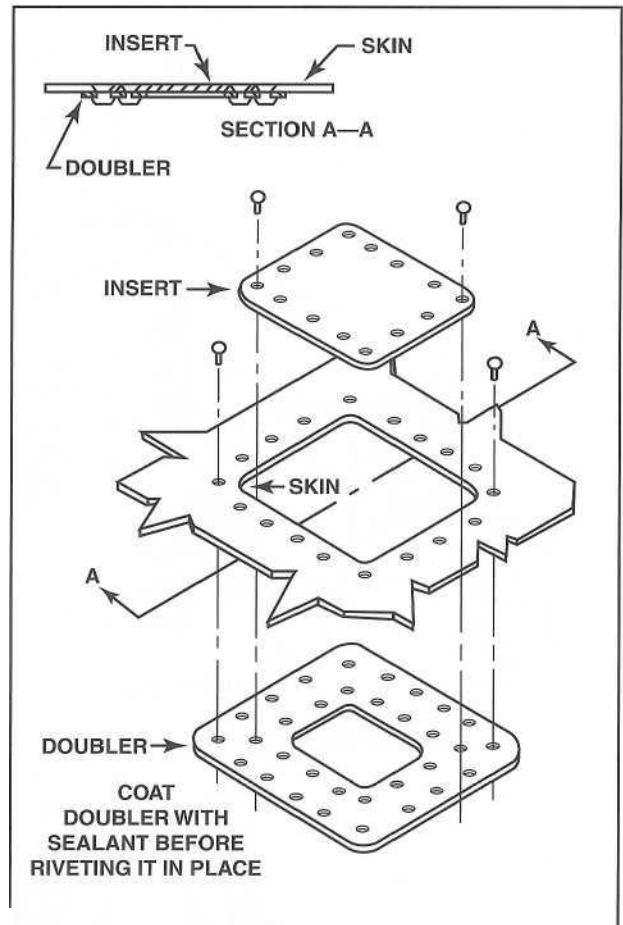

Figure 2-162. A typical repair of a pressurized structure requires that sealant be used to restore air tightness to the pressure vessel of the structure.

skin as well as substructure components. An example of a typical repair for this type damage is shown in figure 2-163.

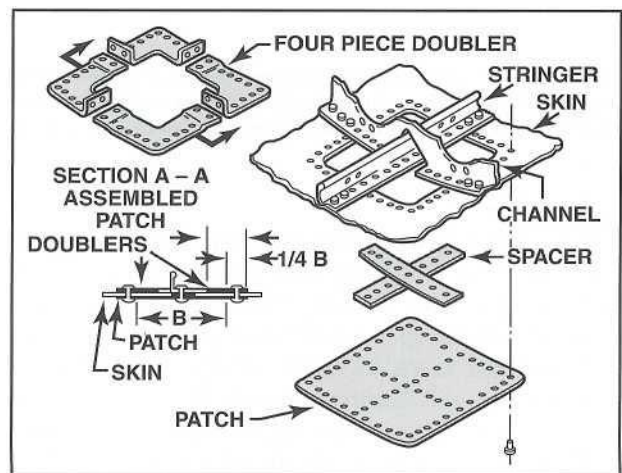

Figure 2-163. If the substructure and skin have been damaged, the substructure must first be repaired and then the skin patched.

Although many repair procedures have been discussed in this chapter, there are countless sheet metal structures in an aircraft. In some cases, damage to these components is minor, and only requires general practices to construct an acceptable repair.

However, it is important to use good judgement in determining if a repair may affect the integrity of the aircraft. Always remember to consult the aircraft manufacturer, or a local FAA inspector before proceeding with any questionable procedures.