

INDUSTRY

HYDRAULIC FLUIDS **SHELL TELLUS AND SHELL IRUS** COMPRESSOR OILS **SHELL CORENA** TURBINE OILS **SHELL TURBO OILS** BEARING AND CIRCULATING OILS **SHELL MORLINA** ELECTRICAL INSULATING OILS **SHELL DIALA** GAS ENGINE OILS **SHELL MYSELLA OIL** INDUSTRIAL GEAR OILS **SHELL OMALA** DETERGENTS **SHELL DOBATEX** REFRIGERATION OILS **SHELL REFRIGERATION OIL** GREASE **SHELL GADUS** PROCESS OILS **SHELL ONDINA OILS** SHELL CATENEX OILS **SLIDEWAY OIL** SHELL TONNA **SHELL GAS COMPRESSOR OIL** DRAGLINE LUBRICANTS **SHELL DRAGLINE ROPE OIL** HEAT TRANSFER OILS **SHELL HEAT TRANSFER OIL PAPER** MACHINE CIRCULATING OILS **SHELL PAPER MACHINE OIL** ROCK DRILL OILS **SHELL AIR TOOL OIL** BIODEGRADABLE **SHELL NATURELLE** CORROSION PREVENTATIVE **SHELL VSI 8235**

SHELL TELLUS

INDUSTRIAL HYDRAULIC FLUIDS





The Shell Tellus range of hydraulic fluids is designed to help make it easy for equipment operators to select the Shell lubricant that will best deliver value to their operations through enhanced wear protection, long oil life and high system efficiency.



PRODUCT-NAME SUFFIX KEY

- E** = Energy saving, high efficiency
- M** = Manufacturing/machine: factory applications
- V** = Versatile applications

APPLICATION ICON KEY

-  Factory/machine applications
-  Long life
-  High load
-  Mobile equipment/exterior use

SHELL TELLUS S2 M

INDUSTRIAL HYDRAULIC FLUID

PREVIOUSLY SHELL TELLUS

DESIGNED TO MEET CHALLENGES

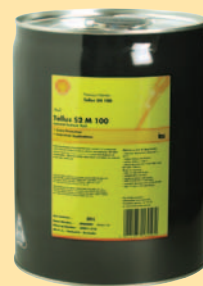

Shell Tellus S2 M fluids are high performance hydraulic fluids that use Shell's unique patented technology to provide outstanding protection and performance.

PERFORMANCE FEATURES

LONG FLUID LIFE-MAINTENANCE SAVING

- Thermally stable in modern hydraulic systems working in extreme conditions of load and temperature. Shell Tellus S2 M are highly resistant to degradation and sludge formation therefore improving system reliability and cleanliness.
- Resist oxidation in the presence of air, water and copper. Turbine Oil Stability Test (TOST) results show outstanding performance for Shell Tellus S2 M; low acidity, low sludge formation, low copper loss; therefore helping to extend oil drain interval life and reduce maintenance costs.
- Shell Tellus S2 M have good chemical stability in the presence of moisture, which ensures long oil life and helps to reduce the risk of corrosion and rusting.

OUTSTANDING WEAR PROTECTION

- Proven anti-wear additives are incorporated to be effective throughout the range of operating conditions, including low and severe duty high load conditions. Outstanding performance in a range of piston and vane pump tests; including the tough Denison T6C (dry and wet versions) and the demanding Vickers 35VQ25.

MAINTAINING SYSTEM EFFICIENCY

- Shell Tellus S2 M are suitable for ultra-fine filtration, an essential requirement in today's hydraulic systems. Unaffected by the usual products of contamination, such as water and calcium, which are known to cause blockage of fine filters. Customers can use finer filters, therefore achieving all the benefits of having in use cleaner fluids.
- Shell Tellus S2 M possess high lubrication properties and excellent low friction characteristics in hydraulic systems operating at low or high speed. Helps prevent stick-slip problems in critical applications enabling very fine control of machinery.
- Careful use of additives to ensure quick air release without excessive foaming. Quick air release helps minimise cavitation and slow oxidation, maintaining system and fluid performance.
- Good water separation properties (demulsibility). Helps resist the formation of water-in-oil emulsions, to help avoid consequent hydraulic system and pump damage.
- Shell Tellus S2 M are suitable for a range of other industrial applications.

APPLICATIONS

- Industrial hydraulic systems.
- Mobile hydraulic fluid power transmission systems.
- Marine hydraulic systems.

COMPATIBILITY AND MISCIBILITY

COMPATIBILITY

Shell Tellus S2 M are compatible with most pumps. However, please consult your Shell representative before using in pumps containing silver plated components.

SEAL AND PAINT COMPATIBILITY

Shell Tellus S2 M are compatible with all seal materials and paints normally specified for use with mineral oils.

SPECIFICATIONS, APPROVALS AND RECOMMENDATIONS

HAS THE APPROVAL OF:

- Cincinnati Machine: P-68 (ISO 32), P-70 (ISO 46), P-69 (ISO 68)
- Dension Hydraulics: (HF-0, HF-1, HF-2)
- Eaton Vickers: M-2950 S
- DIN 51524 Part 2 HLP type.

MEETS THE REQUIREMENTS OF:

- ISO: 11158 (HM fluids)
- GM: LS/2
- AFNOR: NF-E 48-603
- Mannesman Rexroth (RE): 90 220-1
- Swedish Standard (SS): 15 54 34 AM.

TYPICAL PHYSICAL CHARACTERISTICS

CHARACTERISTICS	22	32	46	68	100
ISO Oil Type	HM	HM	HM	HM	HM
Kinematic Viscosity (ASTM D 445)					
@ 0°C mm ² /s	180	338	580	1040	1790
@ 40°C mm ² /s	22	32	46	68	100
@ 100°C mm ² /s	4.3	5.4	6.7	8.6	11.1
Viscosity Index (ISO 2909)	100	99	98	97	96
Density @ 15°C kg/m ³	866	875	879	886	891
Flash Point °C (COC)	210	218	230	235	250
Pour Point °C	-30	-30	-30	-24	-24

SHELL TELLUS S2 V

INDUSTRIAL HYDRAULIC FLUID FOR WIDE TEMPERATURE RANGE

PREVIOUSLY SHELL TELLUS T

DESIGNED TO MEET CHALLENGES

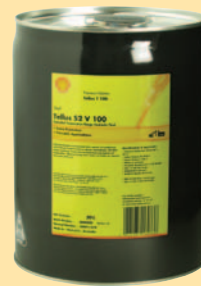

Shell Tellus S2 V fluids are high performance hydraulic fluids that use Shell's unique patented technology with excellent viscosity control under both severe mechanical stress and across a wide range of temperatures. They provide outstanding protection and performance in most mobile equipment and other applications subjected to wider ranges of ambient or operating temperatures.

PERFORMANCE FEATURES

LONG FLUID LIFE – MAINTENANCE SAVING

- Shell Tellus S2 V fluids help extend equipment maintenance intervals by resisting thermal and chemical breakdown. This minimises sludge formation and provides excellent performance in the industry standard ASTM D 943 Turbine Oil Stability Test (TOST).
- Shell Tellus S2 V fluids also have good stability in the presence of moisture, which ensures long fluid life and reduces the risk of corrosion and rusting, particularly in moist or humid environments.
- Highly shear stable viscosity modifiers help minimise variations in the fluid properties throughout the fluid drain interval.

OUTSTANDING WEAR PROTECTION

- Proven zinc-based anti-wear additives are incorporated to be effective throughout the range of operating conditions, including low load and severe duty high load conditions. Outstanding performance in a range of piston and vane pump tests, including the tough Denison T6C (dry and wet versions) and the demanding Vickers 35VQ25, demonstrates how Shell Tellus S2 V fluids can help system components last longer.

MAINTAINING SYSTEM EFFICIENCY

- The extended temperature range capability of Shell Tellus S2 V allows efficient operation of mobile equipment from cold start to normal operating conditions.
- Superior cleanliness, excellent filterability and high performance water separation, air release and anti-foam characteristics all help contribute to maintaining or enhancing the efficiency of hydraulic systems.
- The unique additive system in Shell Tellus S2 V, in combination with superior cleanliness (meeting the requirements of max ISO 4406 21/19/16 class, ex Shell filling lines. As recognised by DIN 51524 specification, the oil is exposed to various influences with transport and storage that could affect the cleanliness level) helps reduce the impact of contaminants on filter blocking, allowing both extended filter life and use of finer filtration for extra equipment protection.
- Shell Tellus S2 V fluids are formulated for fast air release without excessive foaming to help efficient hydraulic power transfer and minimise fluid and equipment impacts of cavitation-induced oxidation that can shorten fluid life.

APPLICATIONS

MOBILE/EXTERIOR HYDRAULIC APPLICATIONS

- Hydraulic and fluid power transmission systems in exposed environments can be subject to wide variations in temperature. The high viscosity index of Shell Tellus S2 V helps deliver responsive performance from cold start conditions to full load, severe duty operation.

PRECISION HYDRAULIC SYSTEMS

- Precision hydraulic systems require excellent control of fluid viscosity over the operating cycle. Shell Tellus S2 V provides greater temperature viscosity stability compared to ISO HM fluids that can help improve the performance of such systems.
- For more severe operating conditions, longer fluid life and enhanced efficiency, the Shell Tellus 'S3' and 'S4' ranges offer additional performance benefits.

COMPATIBILITY

- Shell Tellus S2 V fluids are suitable for use with most hydraulic pumps. However, please consult your Shell representative before using in pumps containing silver plated components.

FLUID COMPATIBILITY

- Shell Tellus S2 V fluids are compatible with most other mineral oil based hydraulic fluids. However, mineral oil hydraulic fluids should not be mixed with other fluid types (e.g. environmentally acceptable or fire resistant fluids).

SEAL AND PAINT COMPATIBILITY

- Shell Tellus S2 V fluids are compatible with seal materials and paints normally specified for use with mineral oils.

SPECIFICATIONS, APPROVALS AND RECOMMENDATIONS

HAS THE APPROVAL OF:

- Denison Hydraulics: (HF-0, HF-1, HF-2)
- Cincinnati Machine: P-68 (ISO 32), P-70 (ISO 46), P-69 (ISO 68)
- Eaton Vickers: M-2950 S, I-286 S.

MEETS OR EXCEEDS THE REQUIREMENTS OF:

- Swedish Standard (SS): 15 54 34 AM
- ISO: 11158 (HV fluids)
- AFNOR: NF-E 48-603
- ASTM: 6158-05 (HV fluids)
- DIN: 51524 Part 3 HVL P type
- GB: 111181-1-94 (HV fluids).

For a full listing of equipment approvals and recommendations please consult your local Shell Technical Helpdesk.

TYPICAL PHYSICAL CHARACTERISTICS

CHARACTERISTICS	15	32	46	68	100
ISO Oil Type	HV	HV	HV	HV	HV
Kinematic Viscosity (ASTM D 445)					
@ -20°C mm ² /s	350	1300	2350		
@ 40°C mm ² /s	15	32	46	68	100
@ 100°C mm ² /s	3.8	6.1	7.9	10.5	14.0
Viscosity Index (ISO 2909)	142	143	143	142	142
Density @ 15°C kg/m ³ (ISO 12185)	872	872	872	877	880
Flash Point °C (COC) (ISO 2592)	170	210	225	225	225
Pour Point °C (ISO 3016)	-42	-39	-36	-30	-30

SHELL TELLUS S3 M

PREMIUM ZINC-FREE INDUSTRIAL HYDRAULIC FLUID

RECOMMENDED REPLACEMENT FOR SHELL TELLUS S



DESIGNED TO MEET CHALLENGES

Shell Tellus S3 M hydraulic fluids are high performance lubricants that use exclusive zinc-free technology to provide outstanding protection and performance in most manufacturing and many mobile equipment operations. They resist breakdown under heat or mechanical stress, helping to prevent damaging deposits that can decrease the efficiency of your hydraulic system.

PERFORMANCE FEATURES

LONG FLUID LIFE – MAINTENANCE SAVING

Shell Tellus S3 M fluids offer an improved capability to extend fluid maintenance intervals and helps reduce equipment downtime through:

- An extended ASTM D 943 TOST lifetime, with an oxidative stability that is up to three times longer than the industry minimum.
- Excellent resistance to breakdown in the presence of water and heat.

These features provide extended maintenance capability without compromising protection or performance, even under severe or extended temperature range applications.

OUTSTANDING WEAR PROTECTION

- Advanced zinc-free anti-wear additives provide protection over a wide range of conditions, including low and severe duty, and high load operation. This protection has been demonstrated in tough industry standard hydraulic pump tests such as the Denison T6C (dry and wet versions), Denison P46 and Eaton Vickers 35VQ25 tests.

MAINTAINING SYSTEM EFFICIENCY

- Superior cleanliness and filterability; coupled with excellent water separation, air release and anti-foam characteristics, all help to maintain or enhance hydraulic system efficiency.
- The filterability of Shell Tellus S3 M is maintained even when the fluid is contaminated with water.
- Shell Tellus S3 M fluids have an ISO 4406 cleanliness of 21/19/16 or better ex Shell filling lines. As recognised by DIN 51524 specification, the oil is exposed to various influences with transport and storage that could effect the cleanliness level.

APPLICATIONS

MANUFACTURING AND INDUSTRIAL HYDRAULIC SYSTEMS

- Shell Tellus S3 M fluids are suitable for a wide range of hydraulic power applications found in manufacturing and industrial environments.

SEVERE DUTY HYDRAULIC SERVICE

- The long-life characteristics of Shell Tellus S3 M fluids can make them particularly suitable for severe duty (e.g. load, temperature) applications or where extended life is required (e.g. remote or inaccessible locations).

MARINE AND MOBILE HYDRAULIC SYSTEMS

- Shell Tellus S3 M fluids are suitable for marine and mobile applications where ISO HM type hydraulic fluids are recommended.

ENVIRONMENTAL IMPACT

- Shell Tellus S3 M has a reduced environmental impact in the event of a leak or accidental spillage compared to conventional zinc-based hydraulic fluids. This is achieved through the use of zinc-free anti-wear technology and low sulphur base oils.

For further reductions in environmental impact, we offer the Shell Naturelle range of environmentally considerate lubricants.

For applications that experience wide temperature variations we recommend the Shell Tellus 'S2' series of hydraulic fluids.

COMPATIBILITY

- Shell Tellus S3 M fluids are suitable for use with most hydraulic pumps.

FLUID COMPATIBILITY

- Shell Tellus S3 M fluids are compatible with most other mineral oil based hydraulic fluids. However, mineral oil hydraulic fluids should not be mixed with other fluid types (e.g. environmentally acceptable or fire-resistant fluids).

SEAL AND PAINT COMPATIBILITY

- Shell Tellus S3 M fluids are compatible with seal materials and paints normally specified for use with mineral oils.

SPECIFICATIONS, APPROVALS AND RECOMMENDATIONS

HAS THE APPROVAL OF:

- Denison Hydraulics: (HF-0, HF-1, HF-2)
- Eaton Vickers (Brochure 694)
- MAG (Cincinnati Machine)
P-68 (ISO 32), P-70 (ISO 46), P-69 (ISO 68)

MEETS THE REQUIREMENTS OF:

- ISO 11158 (HM fluids)
- DIN 51524-2 (HLP oils)
- ASTM 6158 (HM mineral oils)
- SS 15 54 34.

For a full listing of equipment approvals and recommendations please consult your local Shell Technical Helpdesk.

TYPICAL PHYSICAL CHARACTERISTICS

CHARACTERISTICS	22	32	46	68	100
ISO Oil Type	HM	HM	HM	HM	HM
Kinematic Viscosity (ASTM D 445)					
@ 0°C mm ² /s	180	324	565	700	1750
@ 40°C mm ² /s	22	32	46	68	100
@ 100°C mm ² /s	4.3	5.5	6.8	10.2	11.4
Viscosity Index (ISO 2909)	100	105	105	135	100
Density @ 15°C kg/m ³ (ISO 12185) kg/m ³	875	855	865	835	875
Flash Point °C (PMCC) (IP 34) (COC)	204	215	220	250	250
Pour Point °C (ISO 3016)	-30	-33	-33	-51	-33

SHELL TELLUS S4 ME

ADVANCED SYNTHETIC INDUSTRIAL HYDRAULIC FLUID

PREVIOUSLY SHELL TELLUS EE



DESIGNED TO MEET CHALLENGES

Shell Tellus S4 ME hydraulic fluids are designed to help users improve the energy efficiency of their hydraulic systems without compromising the protection of the system or maintenance procedures of their equipment and operations. Shell Tellus S4 ME has been found to improve energy efficiency in applications such as plastic injection moulding and metal pressing compared to Shell Tellus S2 M. In addition, Shell Tellus S4 ME also uses an advanced ashless additive system designed to help equipment service life and lower maintenance costs through providing outstanding wear protection and long oil life capability.

PERFORMANCE FEATURES (COMPARED TO SHELL TELLUS 2M)

ENERGY EFFICIENCY

- With the help of sophisticated system modelling, Shell Tellus S4 ME has been designed to improve the energy efficiency of hydraulic systems through a specially developed formulation that balances the flow, frictional and power transmission characteristics of the fluid. Field evaluation has shown energy efficiency* improvements in such applications.

REDUCE MAINTENANCE COSTS

- Shell Tellus S4 ME offers outstanding performance in all the properties relevant to a hydraulic fluid such as hydraulic pump wear and resistance to breakdown in contact with water or other contaminants.
- Together with an oil life that exceeds the 10,000 hours maximum duration that can be measured in the industry Turbine Oil Stability Test (TOST), Shell Tellus S4 ME offers you the capability to significantly extend oil change intervals, which can help reduce overall maintenance costs.

GREATER EQUIPMENT PROTECTION

- In addition to meeting standard industry and OEM specification requirement, Shell Tellus S4 ME is formulated to provide an exceptional level of additional protection. For instance, Shell Tellus S4 ME results in up to 68% less wear in the Vickers V104C pump wear test than the 50 mg pass/fail limits for many OEMs such as Cincinnati Machine (P-specification), Bosch-Rexroth (RD 90220-1) and Eaton Vickers. Superior cleanliness (meeting the requirements of ISO 4406 21/19/16 class or better ex Shell filling plants. As recognised by DIN 51524 specification, the oil is exposed to various influences with transport and storage that could affect the cleanliness level). Together with outstanding protection against sludge build-up, valve sticking and corrosion, it can help prolong the life of your hydraulic equipment.

APPLICATIONS

INDUSTRIAL HYDRAULIC SYSTEMS

- Particularly suitable for those systems with high intensity hydraulic power usage such as injection moulding and high pressure metal pressing operations and where resistance to high temperatures or long oil life is required.

MOBILE HYDRAULIC SYSTEMS

- Shell Tellus S4 ME is also suitable for use in certain mobile hydraulic fluid power transmission systems and in marine applications and provides superior low temperature fluidity compared to most conventional ISO HM type fluids.

* Actual energy savings may vary depending on application, current oil used, maintenance procedures, condition of equipment, operating conditions and intensity of hydraulic power usage.

ENVIRONMENTAL IMPACT

- Shell Tellus S4 ME oils use an advanced zinc-free (ashless) additive system to help provide reduced environmental impact in the case of leakage or accidental spillage compared to conventional zinc-based hydraulic fluids through the use of ashless anti-wear.

COMPATIBILITY

- Suitable for use with most hydraulic pumps.
- With most other mineral oil based hydraulic fluids. However, mineral oil hydraulic fluids should not be mixed with other fluid types (e.g. environmentally acceptable or fire resistant fluids).
- With seal materials and paints normally specified for use with mineral oils.

SPECIFICATIONS, APPROVALS AND RECOMMENDATIONS

HAS THE APPROVALS OF:

- Denison Hydraulics: (HF-0, HF-1, HF-2)
- Cincinnati Machine: P-68 (ISO 32), P-70 (ISO 46), P-69 (ISO 68)
- Eaton Vickers: M-2950 S, I-286 S
- BoschRexroth
- Arburg: Injection moulding applications.

MEETS OR EXCEEDS THE REQUIREMENTS OF:

- ASTM: D 6158 (HM fluids)
- ISO: 11158 (HM fluids)
- DIN: 51524 Part 2 HLP type
- Swedish Standard (SS): 15 54 34 AM
- AFNOR: NF-E 48-60
- Krauss Maffei.

For a full listing of equipment approvals and recommendations please consult your local Shell Technical Helpdesk.

TYPICAL PHYSICAL CHARACTERISTICS

CHARACTERISTICS	46	68
ISO Fluid Type	HM	HM
Kinematic Viscosity (IP 71)		
@ 0°C mm ² /s	576	1038
@ 40°C mm ² /s	46	68
@ 100°C mm ² /s	6.8	8.7
Viscosity Index (ISO 226)	98	97
Density @ 15°C kg/m ³ (ISO 12185)	0.832	0.835
Flash Point °C (COC) (ISO 2592)	250	250
Pour Point °C (ISO 3016)	-51	-51

LOOKING FOR ENHANCED EFFICIENCY?

Shell Tellus S4 ME

ADVANCED SYNTHETIC HYDRAULIC FLUID

- Proven to enhance energy efficiency*
- Up to four times longer oil life*
- Helps prolongs equipment life

Part of the Shell Tellus hydraulic fluid range – designed to help you make the right choice

DESIGNED TO MEET CHALLENGES



*Compared to Shell Tellus S3 M a mineral oil.

SHELL IRUS FLUID C

HFC TYPE FIRE-RESISTANT HYDRAULIC FLUID

DESIGNED TO MEET CHALLENGES

Shell Irus Fluid C is an advanced water-glycol fire resistant hydraulic fluid containing powerful additives to enhance its anti-wear, anti-corrosion and anti-oxidation properties. The water content is approximately 40% by weight.

PERFORMANCE FEATURES

FIRE RESISTANT FOR HIGH RISK INSTALLATIONS

- As demonstrated in the 7th Luxembourg Report fire resistance tests the product contributes significantly to reduce the fire risk both in presence of flame and hot surfaces due to fire resistance properties.

EXCELLENT COMPONENTS AND FLUID DURATION

- Reliable operation especially compared with fluids of older technologies.

IMPROVED WEAR PERFORMANCES AGAINST MINIMUM INDUSTRY STANDARD

- As demonstrated in the vane pump testing required by the 7th Luxembourg Report the product offers significantly better anti-wear performances than the minimum required by the standard.

APPLICATIONS

Shell Irus Fluid C is particularly suitable for demanding hydraulic applications where there is a high fire risk, such as those found in the Mining and Metal Processing industries.

In order to reduce the water evaporation Shell Irus Fluid C, as for all the ISO HFC type of fluids, should be used below 55°C with a suggested maximum temperature of 45°C.

COMPATIBILITY AND MISCIBILITY

LUBRICATION AND COMPONENT LIFE

In general, water-glycol fluids are less effective bearing lubricants than petroleum mineral hydraulic oils, but are entirely satisfactory in systems containing pumps with plain bearings or lightly loaded ball and roller bearings. However, in common with other water-based fluids a reduction in bearing life can be expected. This will normally be included in the 'derating' made by the pump manufacturer.

In order to increase as much as possible the reliability of the system and reduce its maintenance costs it is important that all components are checked with their manufacturer on whether they are suitable/compatible with water glycol products.

ADDITIONAL INFORMATION

CONTROL OF WATER CONTENT

Water content should be controlled within 35% to 45% by weight. Condensate or de-ionized water should be used for any additions, which should be made slowly while the fluid is circulating.

CONVERSION FROM OTHER TYPES OF FLUIDS

Specific attention should be given in case of converting to Shell Irus Fluid C systems that were previously using lubricants of different types than ISO HFC (e.g. mineral oils or ISO HFDU type of products). In such a case it is suggested you seek advice from your Shell representative about the change over procedure you should follow.

TYPICAL PHYSICAL CHARACTERISTICS

CHARACTERISTICS	
ISO Fluid Type	HFC
Appearance	Transparent Red
Kinematic Viscosity (ASTM D 445)	
@ -20°C mm ² /s	1875
@ 0°C mm ² /s	358
@ 20°C mm ² /s	112
@ 40°C mm ² /s	47
Density @ 15°C kg/m ³ (ISO 12185)	1059
Pour Point °C (ISO 3016)	-57

SHELL IRUS FLUID DR

HFD-R TYPE FIRE-RESISTANT HYDRAULIC FLUID

DESIGNED TO MEET CHALLENGES

Shell Irus Fluid DR is a tri-aryl phosphate ester fire-resistant hydraulic fluid and contains carefully selected additives to give superior oxidation and hydrolytic stability characteristics.

PERFORMANCE FEATURES

- Good fire resistance.
- Non-toxic under EEC regulations.
- Extended fluid change intervals.
- Pump life similar to life with mineral hydraulic oils.
- Fire resistance maintained during the life of the fluid.
- Compatible with most seal materials.

APPLICATIONS

- Hydraulic and power transmission systems used in the steel and mining industries and other applications which call for a fire resistant hydraulic fluid.
- Die-casting machines.
- Billet loaders.
- Electric arc furnaces.
- Forging presses.
- Welding robots.
- Continuous casting machines.
- Hydraulic presses.
- Extrusion presses.

COMPATIBILITY AND MISCIBILITY

SEALS

- Butyl, Viton, Ethylene/Propylene.*

PAINTS

- Epoxy resin paints are compatible.

METALS

- Satisfactory with common constructional metals. Aluminium and its alloys should be hard anodised and not used as bearing surfaces.

* Contact seal suppliers for their advice.

ADDITIONAL INFORMATION

LUBRICATION

The lubricating properties of Shell Irus Fluid DR compare favourably with those of an equivalent mineral oil of the same viscosity.

As a result, in many pumps, they show similar performance (bearing life and wear properties) to mineral oil, although some slight de-rating may be necessary at very high loads. Contact with the pump manufacturer is advisable before use.

TYPICAL PHYSICAL CHARACTERISTICS

CHARACTERISTICS	46
ISO Fluid Type	HFD-R
Appearance	Yellow Clear fluid
Kinematic Viscosity (ASTM D 445)	
@ 0°C mm ² /s	1600
@ 40°C mm ² /s	43
@ 50°C mm ² /s	26
@ 100°C mm ² /s	5.3
Viscosity Index (ISO 2909)	15
Density @ 15°C kg/m ³ (ISO 12185)	1125
Pour Point °C (ISO 3016)	-18

SHELL CORENA

AIR COMPRESSOR OILS

The Shell Corena range of air compressor oils is designed to help make it easy for equipment operators to select the Shell oil that will best deliver value to their operations through enhanced wear protection, long oil life and high system efficiency.

THE SHELL CORENA 'R' RANGE

Rotary vane and screw air compressor oils for use in stationary and mobile air compressors

THE SHELL CORENA 'P' RANGE

Reciprocating (piston) air compressor oils for safe and reliable operation in demanding high-pressure applications

INCREASINGLY EFFICIENT PROTECTION

ADVANCED TIER 4
PREMIUM TIER 3
MAIN LINE TIER 2

Shell Corena S4 R

SYNTHETIC

- Extra long life
- Improved efficiency
- Severe applications



Formulated for better protection, longer oil life and better system efficiency



Shell Corena S3 R

- Long life
- High efficiency



Shell Corena S4 P

SYNTHETIC

- Extra long life
- Improved efficiency
- Severe applications



Formulated for better protection, longer oil life and better system efficiency



Shell Corena S2 P

- Reliable protection
- Standard life applications



PRODUCT-NAME SUFFIX KEY

- P** = High pressure/reciprocating (piston) air compressors
R = Rotary vane and screw air compressors

APPLICATION ICON KEY

- Rotary vane and screw air compressors
- Factory/machine applications
- Mobile air compressors
- High temperature
- Reciprocating (piston) air compressors

OIL PRODUCT	REPLACEMENT PRODUCT	PERFORMANCE FEATURES	APPLICATIONS
Shell Corena AS	Shell Corena S4 R 46, 68	<ul style="list-style-type: none"> ■ Extra long life ■ System efficiency ■ Severe applications 	<ul style="list-style-type: none"> ■ Rotary vane and screw air compressors ■ Factory/machine applications ■ Mobile air compressors ■ High temperature
Shell Corena S	Shell Corena S3 R 46, 68	<ul style="list-style-type: none"> ■ Long life ■ System efficiency 	<ul style="list-style-type: none"> ■ Rotary vane and screw air compressors ■ Factory/machine applications ■ Mobile air compressors
Shell Corena AP	Shell Corena S4 P 68, 100	<ul style="list-style-type: none"> ■ Extra long life ■ System efficiency ■ Severe applications 	<ul style="list-style-type: none"> ■ Factory/machine applications ■ Reciprocating (piston) air compressors ■ High temperature
Shell Corena P	Shell Corena S2 P 68, 100, 150	<ul style="list-style-type: none"> ■ Reliable protection ■ Standard life applications ■ Severe applications 	<ul style="list-style-type: none"> ■ Factory/machine applications ■ Reciprocating (piston) air compressors

SHELL CORENA S2 P

RECIPROCATING (PISTON) AIR COMPRESSOR OIL

PREVIOUSLY SHELL CORENA P

DESIGNED TO MEET CHALLENGES

Shell Corena S2 P is a premium quality reciprocating air compressor lubricant. It is based on a blend of specially selected base oils to provide a level of performance approaching that of synthetic oils.

PERFORMANCE FEATURES

LONG OIL LIFE-MAINTENANCE SAVING

- Allows the service interval between valve and piston maintenance to be extended over normal service practices due to low deposits forming tendencies. Compressors can be kept in service for much longer periods, operating at a consistently high level of efficiency.

ENHANCED AIR-LINES SAFETY

- In discharge air-lines, the combination of rust particles, dispersed in carbonaceous deposits, coupled with heat from recently compressed air, can cause an exothermic reaction leading to the possibility of fires and explosion. Shell Corena S2 P helps to minimise the likelihood of this danger arising.

MAINTENANCE SYSTEM EFFICIENCY

- Resistant to the formation of carbon deposits and lacquer on valves and piston crowns, caused by the by-products of corrosion, such as ferric oxides and hydroxides, at high working temperatures and pressures. Such deposits can cause serious damage, lower compressor efficiency and increase maintenance costs.
- Shell Corena S2 P separates readily from water allowing excess water to be drained from the oil circulation system, thus preventing accelerated corrosion and a reduction in lubrication efficiency. This also helps to separate oil from condensate in oil/water separators and drier units.

OUTSTANDING WEAR PROTECTION

- Effectively protects all metal surfaces from corrosion. Protects all sensitive machinery parts (e.g. housings, valves, bearings, from wear to help prolong the service intervals).

APPLICATIONS

RECIPROCATING AIR COMPRESSORS

- Industrial reciprocating air compressors operating with air discharge temperatures of up to 220°C.

BREATHING AIR COMPRESSORS

- Shell Corena S2 P may be used in breathing air compressors, provided subsidiary clean-up apparatus is used to ensure that the air produced is fit for breathing.

COMPATIBILITY AND MISCIBILITY

SEAL COMPATIBILITY

Shell Corena S2 P is compatible with all sealing materials commonly used in air compressors.

SPECIFICATIONS, APPROVALS AND RECOMMENDATIONS

- DIN 51506 VDL
- ISO 6743-3:2003 DAA Normal Duty.

TYPICAL PHYSICAL CHARACTERISTICS

CHARACTERISTICS	68	100	150
Kinematic Viscosity (ASTM D 445)			
@ 40°C mm ² /s	68	100	155
@ 100°C mm ² /s	7.8	9.2	12.1
Density @ 15°C kg/m ³	883	899	902
Flash Point (COC) °C (ASTM D 92)	235	240	240
Pour Point °C (ASTM D 97)	-33	-33	-30
Neutralisation Value mg KOH/g	0.3	0.3	0.3
Sulphated Ash % m	0.06	0.06	0.06
Oxidation Stability (delta-CCR) % m	1.8	2	2.3
Properties of the distillation residues 20% (DIN 51562)			
Carbon residue (CCR) %m	0.3	0.3	0.3
Rust Prevention Properties (steel) degrees (ASTM D 665-B)	Pass	Pass	Pass
Water Stability @ 54°C min (ASTM D 1401) @ 82°C min	30	-	-
	-	20	20

SHELL CORENA S3 R

PREMIUM ROTARY AIR COMPRESSOR OIL

PREVIOUSLY SHELL CORENA S

DESIGNED TO MEET CHALLENGES

Shell Corena S3 R is a premium quality lubricant developed for the lubrication of rotary sliding vane and screw air compressors. It is based on a blend of selected solvent refined base oils and carefully chosen additives.

PERFORMANCE FEATURES

LONG OIL LIFE-MAINTENANCE SAVING

- Shell Corena S3 R will allow for significant increases in oil drain intervals (compared to basic mineral compressor oil), where allowed by manufacturers – up to a maximum of 6,000 hours, even when operating at a continuous maximum discharge air temperature of up to 100°C.
- Resists formation of carbon deposits in sliding vane slots enabling them to move freely. Also resists deposit formation on rotating components of screw compressors. As a consequence high levels of compressor efficiency can be maintained for long periods in both types of compressor.
- Depending on intake air quality, duty cycle and ambient conditions, especially hot and humid type climates as found in the Asian and Pacific regions, a reduced oil drain period is recommended.

MAINTAINING SYSTEM EFFICIENCY

- The careful selection of base oils and additives provides rapid air release without excessive foaming to give excellent operation even under cycling conditions.
- The product is easily separated from water, keeping the system in good condition even when contaminated with water.
- Shell Corena S3 R is formulated to reduce sludge and deposit formation from the thermal degradation processes, even at very high temperatures, maintaining compressor efficiency.
- Coupled with the oil's long life capability is its ability to maintain internal surface cleanliness in service. This is important to maintain high levels of performance for the compressor and separator/coalescer.

OUTSTANDING WEAR PROTECTION

- Effectively protects all metal surfaces from corrosion. Protects all sensitive machinery parts (e.g. gears, screws, bearings, from wear to help prolong the service intervals).

APPLICATIONS

ROTARY SLIDING VANE AIR COMPRESSORS

- Oil flooded or oil injected, single or two-stage compressors, operating at pressures of up to 10 bar and with air discharge temperatures of up to 100°C.

SCREW AIR COMPRESSORS

- Oil flooded or oil injected, single or two-stage compressors, operating at pressures of up to 20 bar and with air discharge temperatures of up to 100°C.

COMPATIBILITY AND MISCIBILITY

SEAL COMPATIBILITY

- Shell Corena S3 R is compatible with all sealing materials commonly used in air compressors.

SPECIFICATIONS, APPROVALS AND RECOMMENDATIONS

- ISO 6743-3A-DAJ.

TYPICAL PHYSICAL CHARACTERISTICS

CHARACTERISTICS	46	68
Kinematic Viscosity (ASTM D 445) @ 40°C mm ² /s	46	68
@ 100°C mm ² /s	6.9	8.9
Density @ 15°C kg/m ³ (ASTM D 1298)	868	873
Flash Point °C (COC) (ASTM D 92)	230	248
Pour Point °C (ASTM D 97)	-30	-30
Water Separability @ 54°C min. (ASTM D 1401)	15	15

SHELL CORENA S4 R

ADVANCED SYNTHETIC ROTARY AIR COMPRESSOR OIL

PREVIOUSLY SHELL CORENA AS

Shell Corena S4 R is an advanced air compressor lubricant using unique additive technology, capable of giving outstanding performance in oil-flooded air compressors of screw or vane design. Based on specially selected PAO base fluids, Shell Corena S4 R provides long oil life and effective lubrication in severe applications.

PERFORMANCE FEATURES

LONG OIL LIFE-MAINTENANCE SAVING

- Shell Corena S4 R will allow for significant increases in oil drain intervals (compared to mineral compressor oil) with oil analysis, where allowed by manufacturers – up to a maximum of 12,000 hours, even when operating at a continuous maximum discharge air temperature in excess of 100°C. Depending on intake air quality, duty cycle and ambient conditions, especially in hot and humid type climates as found in the Asian and Pacific regions, a reduced oil drain period is recommended.
- Shell Corena S4 R is formulated to reduce sludge and deposit formation from thermal degradation processes, even at very high temperatures, maintaining compressor efficiency.
- Reduced change of viscosity with change in operating temperature in comparison to conventional mineral oil-based products. This provides low starting viscosity together with higher viscosity at operating temperature.

OUTSTANDING RESISTANCE TO OXIDATION

- Shell Corena S4 R is designed to resist the formation of carbon deposits and the formation of sludge in all moving parts of sliding vane and screw compressors, helping to ensure maximum output of the machine throughout the service interval.

OUTSTANDING WEAR PROTECTION

- Effectively protects all metal surfaces from corrosion. Protects all sensitive machinery parts (e.g. gears, screws, bearings, from wear to help prolong the service intervals).

MAINTAINING SYSTEM EFFICIENCY

- Resulting in a low foaming tendency and very good air release and water shedding properties. This helps to separate oil from air and water in two-stage compressor intercoolers, oil/water separators and drier units.
- The product is easily separated from water, keeping the system in good condition even when contaminated with water.
- Shell Corena S4 R has low volatility and oil carry over to provide reduced oil top-up requirements in combination with increased air quality.

APPLICATIONS

ROTARY SLIDING VANE AND SCREW AIR COMPRESSORS

- Oil flooded/oil-injected single and two-stage compressors, in particular those operating with higher output pressures of up to 25 bar and with air discharge temperatures higher than 100°C (including intermittent operation under these conditions).

EQUIPMENT RUNNING UNDER ARDUOUS CONDITIONS

- May also be used where exceptionally high ambient temperatures are found, when the oil temperature cannot be reduced to normal levels.

ABB TURBOCHARGERS

- Recommended for use in ABB turbochargers fitted to low and medium speed diesel engines used in marine and power generation applications.

COMPATIBILITY AND MISCIBILITY

MISCIBILITY

- Shell Corena S4 R is fully miscible with mineral oils, although dilution with mineral lubricants will markedly reduce its performance. Care must be taken to ensure that Shell Corena S4 R is not mixed with other types of synthetic fluids.

SEAL COMPATIBILITY

- Shell Corena S4 R is compatible with all sealing materials commonly used in air compressors.

SPECIFICATIONS, APPROVALS AND RECOMMENDATIONS

- ABB for use in VTR turbochargers, with a maximum oil change interval of 5,000 hours (HZTL 90617, List 3).
- ISO 6743-3A-DAJ.

TYPICAL PHYSICAL CHARACTERISTICS

CHARACTERISTICS	46	68
Kinematic Viscosity (ASTM D 445)		
@ 40°C mm ² /s	46	68
@ 100°C mm ² /s	7.7	10.2
Viscosity Index (ISO 2909)	135	135
Density @ 15°C kg/m ³ (ASTM 1298)	843	848
Flash Point °C (COC) (ASTM D 92)	230	248
Pour Point °C (ASTM D 97)	-45	-45
Air Release minutes	2	4
Rust Prevention Properties (ASTM D 665-B)	Pass	Pass
Water Separability mins (ASTM D 1401)	10	10
Rotating Pressure Vessel Oxidation mins (ASTM D 2272)	2200	2200
FZG Load Carrying Test	>12	>12

SHELL CORENA S4 P

ADVANCED SYNTHETIC RECIPROCATING (PISTON) AIR COMPRESSOR OIL

PREVIOUSLY SHELL CORENA AP

DESIGNED TO MEET CHALLENGES

Shell Corena S4 P is an advanced reciprocating air compressor lubricant and is based on specially selected synthetic ester fluids. It incorporates the latest additive technology to provide outstanding performance.

PERFORMANCE FEATURES

LONG OIL LIFE-MAINTENANCE SAVING

- Developed specifically for heavy-duty reciprocating air compressors. This includes reciprocating air compressors subjected to overloading, intermittent or continuous operation. Shell Corena S4 P is designed to provide safe, reliable and effective lubrication for extended service periods where mineral compressor lubricants are unsatisfactory.
- The extreme low tendency for deposit build-up ensures continued high compressor performance over long periods. It enables the normal valve maintenance period, typically between 250 and 1,000 hours of operation using conventional mineral oils, to be extended to 2,000, or even 4,000 hours.

ENHANCED AIR-LINE SAFETY

- The absence of deposit formation has a very important safety related benefit. In discharge air-lines, the combination of rust particles, dispersed in carbonaceous deposits, coupled with heat from recently compressed air, can cause an exothermic reaction leading to the possibility of fires and explosion. Shell Corena S4 P helps to minimise the likelihood of this danger arising.

OUTSTANDING WEAR PROTECTION

- Effectively protects all metal surfaces from corrosion. Protects all sensitive machinery parts (e.g. gears, screws, bearings, from wear to help and prolong the service intervals).

MAINTAINING SYSTEM EFFICIENCY

- Resistant to the formation of carbon deposits and lacquer on valves and piston crowns, caused by the by-products of corrosion such as ferric oxides and hydroxides, at high working temperatures and pressures. Such deposits can cause serious damage, lower compressor efficiency and increase maintenance costs.
- Separates readily from water preventing accelerated corrosion and facilitating separation from condensate.

APPLICATIONS

RECIPROCATING AIR COMPRESSORS

- All industrial reciprocating air compressors, in particular up to and above air discharge temperatures of 220°C with continuous high delivery pressures.

BREATHING AIR COMPRESSORS

- Shell Corena S4 P may be used in breathing air compressors, provided subsidiary clean-up apparatus is used to ensure that the air produced is fit for breathing.

COMPATIBILITY AND MISCIBILITY

SEAL COMPATIBILITY

- Shell Corena S4 P, in common with other ester-based lubricants, is not compatible with all seal materials, and some older compressors may need to have the seals changed before they can be run on the new grades.

MISCIBILITY

- Shell Corena S4 P oils are fully miscible with mineral oils, although dilution with mineral lubricants will markedly reduce its performance.

COMPATIBILITY GUIDE

Acceptable	High nitrile content (SE85)	>36% acrylonitrile
Majority Acceptable	Medium nitrile content (SE70)	30–36% acrylonitrile
Not Acceptable	Low nitrile content	<30% acrylonitrile

SPECIFICATIONS, APPROVALS AND RECOMMENDATIONS

- DIN 51506 VDL
- ISO/DP 6521-L-DAB – medium duty
- ISO 6743-3:2003 DAB – severe duty
- EN 12021.

TYPICAL PHYSICAL CHARACTERISTICS

CHARACTERISTICS	68	100
Kinematic Viscosity (ASTM D 445) @ 40°C mm ² /s	68	100
@ 100°C mm ² /s	8.5	10.2
Density @ 15°C kg/m ³ (ASTM D 445)	990	988
Flash Point °C (COC) (ASTM D 92)	250	260
Pour Point °C (ASTM D 97)	–51	–39
Sulphated Ash %m (DIN 51575)	<0.02	0.02
Rust Prevention Properties (24 hours)	Pass	Pass
Copper Corrosion (100°C / 3 hours) (ASTM D 130)	1b	1b
Water Separability @ 54°C min. (ASTM D 1401)	30	–
@ 82°C min.	–	25

WANT TO INCREASE PRODUCTIVITY?



Shell Corena S4 R

ADVANCED SYNTHETIC OIL FOR SLIDING-VANE
AND SCREW ROTARY AIR COMPRESSORS

- Enhanced compressor efficiency and availability for increased productivity.
- Designed to extend oil and equipment life.
- Keeps high-temperature and high-pressure equipment working efficiently for longer.

Part of the Shell Corena air compressor oil range
– designed to help you make the right choice

DESIGNED TO MEET CHALLENGES

SHELL TURBO

INDUSTRIAL TURBINE OILS

A RANGE OF TURBINE OILS TO MEET YOUR NEEDS

To meet the challenges of a wide range of equipment designs and applications, Shell has designed a portfolio of oils that helps you to choose a product to match your technical and operational needs.

PRODUCT-NAME SUFFIX KEY

- GT** = Gas turbines
- CC** = Combined-cycle turbines
- T** = Steam, hydro turbines

APPLICATION ICON KEY

-  Turbine
-  Power station
-  High temperature
-  Turbo compressor
-  Enclosed gear

HEAVY-DUTY GAS TURBINES AND TURBOCOMPRESSORS.

INDUSTRIAL STEAM, HEAVY-DUTY GAS AND COMBINED-CYCLE TURBINES, INCLUDING GEARED SYSTEMS.

INDUSTRIAL STEAM AND LIGHT-DUTY GAS TURBINES AND TURBOCOMPRESSORS.

INCREASINGLY EFFICIENT PROTECTION >>>>

ADVANCED TIER 4
PREMIUM TIER 3
MAIN LINE TIER 2

Shell Turbo GT

SYNTHETIC

- Extra long life
- High temperature operation



Shell Turbo CC

- Extra long life
- Extra protection



Shell Turbo T

- Reliable performance
- Reliable protection



SHELL TURBO OILS T

HIGH QUALITY INDUSTRIAL STEAM AND GAS TURBINE OIL

DESIGNED TO MEET CHALLENGES

Shell Turbo Oils T have long been regarded as the industry standard turbine oil. Building on this reputation, Shell Turbo Oils T have been developed to meet the demands of the most modern non-geared steam turbine systems and light duty gas turbines. Shell Turbo Oils T are formulated from high quality hydrotreated base oils and a combination of zinc-free additives that provide excellent oxidative stability, protection against rust and corrosion, low foaming and excellent demulsibility.

PERFORMANCE FEATURES

STRONG CONTROL OF OXIDATION

- The use of inherently oxidatively stable base oils together with an effective inhibitor package provides high resistance to oxidative degradation. The result is extended oil life, minimising the formation of aggressive corrosive acids, deposits and sludge, helping to reduce your operating costs.

HIGH RESISTANCE TO FOAMING AND RAPID AIR RELEASE

- The oils are formulated with a non-silicone anti-foam additive, which generally controls foam formation. This feature coupled with fast air-release from the lubricant reduces the possibility of problems such as pump cavitation, excessive wear and premature oil oxidation, helping to give you increased system reliability.

POSITIVE WATER-SHEDDING PROPERTIES

- Robust demulsibility control such that excess water, common-place in steam turbines, can be drained easily from the lubrication system, minimising corrosion and premature wear and lowering the risk of unplanned maintenance.

EXCELLENT RUST AND CORROSION PROTECTION

- Helps prevent the formation of rust and guards against onset of corrosion ensuring protection for equipment following exposure to humidity or water during operation and during shut-downs, minimising maintenance.

RESISTANT TO REACTION WITH AMMONIA

- The use of highly refined base oils and specific additives, resistant to attack by ammonia, minimises the possibility of damaging oil soluble/insoluble ammonia compounds being formed in the lubricant. Shell Turbo Oils T mitigate the formation of these deposits, which could impair the reliable operation of bearings and seal oil systems.

APPLICATIONS

Shell Turbo Oils T are available in ISO grades 32, 46, 68 and 100 suited for application in the following areas:

- Non-geared industrial steam turbines.
- Non-geared light duty gas turbines.
- Water turbine lubrication.
- Compressor applications.
- Numerous applications where strong control over rust and oxidation is required.

SPECIFICATIONS, APPROVALS AND RECOMMENDATIONS

MEETS OR EXCEEDS SPECIFICATIONS OF:

- General Electric: GEK 28143b – Type I (ISO 32), GEK 28143b – Type II (ISO 46), 46506E
- Siemens-Westinghouse: 21T0591 and PD-55125Z3
- DIN: 51515 part 1 and 2
- ISO: 8068
- Solar: ES 9-224W, Class II
- GEC: Alstom NBA P50001
- JIS: K2213 Type 2
- BS: 489-1999
- ASTM: D 4304, Type I
- Siemens/Mannesmann Demag: 800037 98.

APPROVED BY OEM AGAINST:

- Siemens Power Generator: TLV 9013 04 and TLV 9013 05
- Alstom Power Turbo-Systems: HTGD 90-117
- Man Turbo: SP 079984 D0000 E99
- Cincinnati Approvals: P-38 Turbo T32; P-55 Turbo T46; P-54 Turbo T68.

TYPICAL PHYSICAL CHARACTERISTICS

CHARACTERISTICS	32	46	68	100
Kinematic Viscosity @ 40°C mm ² /s (ASTM D 445)	32	46	68	100
@ 100°C mm ² /s	5.2	6.6	8.5	11.1
Colour	10.5	10.5	10.5	<1.0
Flash Point °C (COC)	>215	220	240	250
Pour Point °C	≤-12	≤-12	-9	≤-9
Total Acid Number mg KOH/g	0.05	0.05	0.05	0.05
Foaming ml/ml (ASTM D 892)				
Sequence I	30/Nil	30/Nil	30/Nil	30/Nil
Sequence II	20/Nil	20/Nil	20/Nil	20/Nil
Sequence III	30/Nil	30/Nil	30/Nil	30/Nil
Air Release min.	2	4	6	10
Water Demulsibility min.	15	15	20	20
Steam Demulsibility secs.	150	153	183	210
Copper Corrosion 100°C/3hrs	1b	1b	1b	1b
Rust Control after water washing	Pass	Pass	Pass	Pass
FZG, Fail Load Stage	6	7	7	7
Oxidation Control Tests				
a) TOST life modified hr	>10,000	>1,000	>1,000	>10,000
b) TOST 1,000hr sludge mg	30	3	3	30
c) RPVOT min.	>950	>90	>80	>700

SHELL TURBO OIL GT

HIGH PERFORMANCE INDUSTRIAL GAS TURBINE LUBRICANT



DESIGNED TO MEET CHALLENGES

Shell Turbo Oil GT has been developed for the most severe operating conditions imposed by modern, heavy-duty industrial gas turbines.

PERFORMANCE FEATURES

OUTSTANDING OXIDATION STABILITY

- The lubricant's service life depends, to a great extent, on its oxidative stability. Excellent results in both the 'hot oxidation test' (FTM5308) and the 'TOST' life test (ASTM-D943) clearly demonstrates Shell Turbo Oil GT potential for extended service life compared to conventional mineral oil technology.

EXCELLENT THERMAL STABILITY

- Higher bearing temperatures which are particularly severe during stop/start cycling conditions, may lead to bearing deposits and the formation of harmful sludge in the system which subsequently may result in expensive 'downtime' and reduce service life of system components. Shell Turbo Oil GT is formulated to give greater protection against thermal degradation and hence may significantly contribute to lower operating and maintenance costs.

EXCELLENT AIR RELEASE CHARACTERISTICS

- Effective air release with a minimum of foaming tendency as required by modern gas turbines.

APPLICATIONS

POWER AND INDUSTRIAL HEAVY-DUTY GAS TURBINES

- Shell Turbo Oil GT is used as lubricating oil for main shaft bearings and mechanical gears as well as governor oil in the turbine control valves in modern gas turbines.

FURTHER INDUSTRIAL APPLICATIONS

- Shell Turbo Oil GT may also be used for other industrial applications requiring a high performance gas turbine oil, like lubrication of turbo compressors.

SPECIFICATIONS, APPROVALS AND RECOMMENDATIONS

EXCEEDS SPECIFICATIONS OF:

- DIN: 51515-1, 51515-2
- SIEMENS: TLV 9013 04
- GEK: 32568F, GEK 107395a, GEK 28143B – Type I (ISO 32), GEK 28143B – Type II (ISO 46)
- ALSTOM: HTGD 90-117, ASTM 4304-06A Type III
- ALSTOM/ABB: HTGD 90-117T
- SOLAR: ES 9-224 W Class II.

TYPICAL PHYSICAL CHARACTERISTICS

CHARACTERISTICS	32
Kinematic Viscosity (ASTM D 445) @ 40°C mm ² /s	31.4
@ 100°C mm ² /s	5.78
Viscosity Index (ASTM D 2270)	>125
Density @ 15°C kg/m ³ (IP 365)	844
Flash Point °C (COC) (ASTM D 92)	230
Pour Point °C (ASTM D 97)	-15
Neutralisation Value mg KOH/g (ASTM D 974)	0.10
Air Release Behaviour @ 50°C min. (ASTM D 3427)	2
Copper Corrosion (3h/100°C) (ASTM D 974)	1b
Rust-Preventing Properties (ASTM D 665 A&B)	No Rust
Oxidation Control Tests	
RPVOT minutes (ASTM D 2272)	>1,000
Modified RPVOT %	>95%
TOST lifetime hr (ASTM D 943)	>8,000
TOST 1,000 hrs sludge mg/kg (IP 157)	<40
Oxidation Test 175°C/72hrs (FTM-971b-5308-7)	
Sludge content mg	52
Viscosity change %	+5

SHELL TURBO OIL CC

PREMIUM QUALITY INDUSTRIAL GAS, STEAM AND COMBINED CYCLE TURBINE OIL

DESIGNED TO MEET CHALLENGES

Shell Turbo Oil CC has been developed to meet the severe demands imposed by modern, heavy-duty turbine applications, exceeding a number of major gas and steam manufacturers lubricant specifications.

A patented, metal free additive technology, ensures that this product offers substantially improved performance over conventional turbine oils. Its unique combination of excellent oxidative stability, sludge control and surface properties make Turbo CC the first choice lubricant for emerging combined cycle turbine technology, as well as existing gas and steam turbine plants.

PERFORMANCE FEATURES

SUPERIOR OXIDATION RESISTANCE

- High temperatures and extended oil drain intervals demand superior oxidation properties of the oil. Shell Turbo Oil CC's excellent oxidative stability helps reduce the formation of sludge and other harmful oxidation products, contributing to extended oil life, less maintenance and less downtime.

OUTSTANDING THERMAL RESISTANCE

- Modern turbines impose high thermal stress on the oil, increasing the risk of failures. Shell Turbo Oil CC is specially designed to cope with these conditions. Its outstanding thermal stability, coupled with resistance to formation of lacquer, helps reduce the possibility of unplanned outages.

RAPID AIR RELEASE AND HIGH RESISTANCE TO FOAMING

- High oil flows contribute to the possibility of entrapped air, which can lead to pump cavitation, premature oil oxidation and excessive wear. Shell Turbo Oil CC exhibits excellent surface properties with minimal foam formation and rapid air-release, which minimises air entrapment, reducing these effects of high oil flows to a minimum.

EXCELLENT WATER-SHEDDING PROPERTIES

- Water contamination is common place in steam turbines, causing corrosion and affecting bearing lubrication. Because of Shell Turbo Oil CC's outstanding demulsibility, water can be drained easily from the lubrication system, protecting the installation against corrosion and premature wear.

GOOD LOAD CARRYING CAPACITY

- Help to reduce excessive gear tooth and turbine component wear making it suitable for use in turbines with highly loaded gears. Helps minimise downtime and maintenance costs.

APPLICATIONS

- Power generation combined cycle turbines
- Industrial steam turbines
- Industrial gas turbines.

SPECIFICATIONS, APPROVALS AND RECOMMENDATIONS

EXCEEDS SPECIFICATIONS OF:

- General Electric: GEK 28143 A, GEK 32568F, GEK 46506E, GEK101941A, GEK 107395A.

- Siemens-Westinghouse: 21 T0591 and 55125Z3
- Solar: ES 9-224, class II
- DIN: 51515 Part 1 L-TD and Part 2 L-TG
- ISO: 8068 L-TGD and L-TGS
- GEC: Alstom NBA P50001A
- JIS: K-2213 Type 2
- BS: 489-1999
- Siemens/Mannesmann Demag: 800 037 98 TD/32/TD46
- ASTM: D 4304-06A, Type I, II, III.

APPROVED BY OEM AGAINST:

- Siemens TLV 9013 04
- Alstom HTGD 90 117.

TYPICAL PHYSICAL CHARACTERISTICS

CHARACTERISTICS	32	46
Kinematic Viscosity @ 40°C mm ² /s	32	46
@ 100°C mm ² /s	5.4	6.9
Viscosity Index	–	105
Flash Point °C (COC)	218	238
Pour Point °C	–12	–12
Total Acid Number mg KOH/g	0.16	0.16
Foaming ml/ml		
Sequence I	10/Nil	10/Nil
Sequence II	20/Nil	20/Nil
Sequence III	10/Nil	10/Nil
Air Release	4 min.	4 min.
Water Demulsibility	15 min.	15 min.
Rust Control after water washing	Pass	Pass
Load Carrying Capacity (FZG) load stage fail	9 min.	9 min.
Oxidation Control Tests		
a) TOST life	>10,000	>10,000
b) RPVOT	>1,300	>1,300
c) FTM-791b-5308:		
TAN increase mg KOH/g	+0.6	+0.6
Viscosity Increase @ 40°C %	+8.0	+8.0
Sludge formation mg	98	98

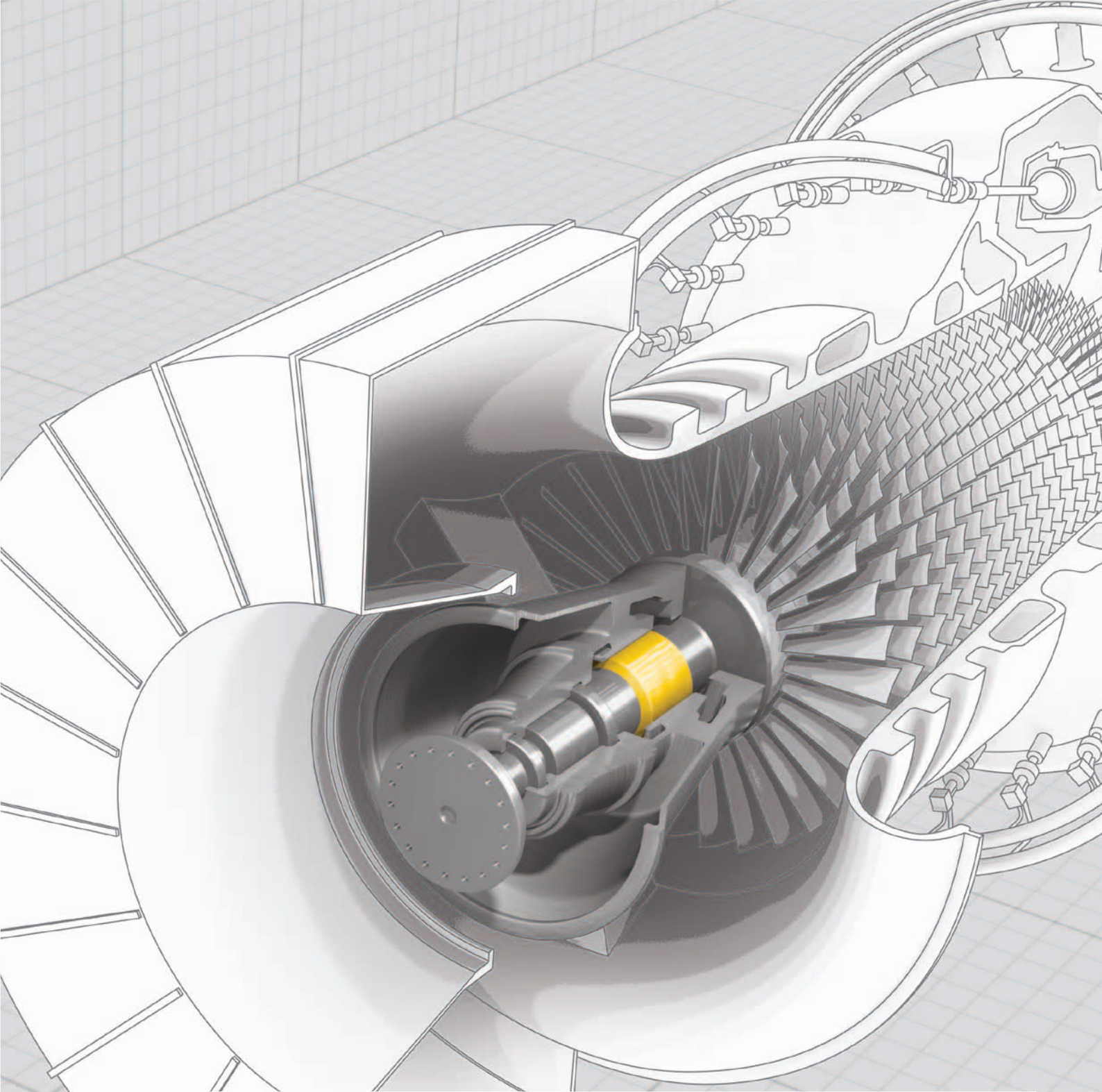

**DESIGNED TO DELIVER
RELIABILITY AND EFFICIENCY.
JUST LIKE OUR TURBINE OILS
- SHELL TURBO.**

DESIGNED TO MEET CHALLENGES

SHELL MORLINA S2 BL

SPECIAL APPLICATION BEARING AND CIRCULATING OILS

*PREVIOUSLY SHELL MORLINA 5
RECOMMENDED REPLACEMENT FOR SHELL MORLINA 10*

DESIGNED TO MEET CHALLENGES

Shell Morlina S2 BL oils are special low viscosity, solvent refined mineral oils blended with zinc free additives, help to provide extended performance in the high speed spindles of machine tools.

PERFORMANCE FEATURES

LONG OIL LIFE – MAINTENANCE SAVING

- Shell Morlina S2 BL oils are formulated with a well proven rust and oxidation inhibitor package that provides high resistance to oxidation caused by heat in the presence of air, water and metal catalysts, such as copper, and helps to prolong oil life and lower maintenance costs.

RELIABLE WEAR AND CORROSION PROTECTION

- The special additives provide efficient anti-wear performance without reacting to the softer metals in bearings and enhance machine reliability.
- In addition the additive package enhances the oil's natural corrosion protective properties and helps to prolong bearing life.

MAINTAINING SYSTEM EFFICIENCY

- The low viscosity components of these oils have been chosen to help promote the smooth running of high speed machine elements and minimise heat build up through frictional energy losses.

APPLICATIONS

HIGH SPEED SPINDLES

- The low viscosity fluids (ISO grades 5 and 10) are particularly suitable for the lubrication of high speed spindles in machine tools.
- Pneumatic systems specifying an ISO 10.

SPECIFICATIONS, APPROVALS AND RECOMMENDATIONS

Shell Morlina S2 BL oils are designed to meet specifications requiring a premium quality, light viscosity oil for applications running at high speeds such as those found in high speed frames and automated machine tools.

- Cincinnati Machine P-62 (ISO VG 5, 10).

PAINT COMPATIBILITY

- Shell Morlina S2 BL oils are compatible with seal materials and paints normally specified for use with mineral oils.

TYPICAL PHYSICAL CHARACTERISTICS

CHARACTERISTICS	10
Kinematic Viscosity (ASTM D 445) @ 40°C mm ² /s	10
@ 100°C mm ² /s	2.3
Density @ 15°C kg/m ³ (ISO 12185)	881
Flash Point °C (COC) (ASTM D 93)	150
Pour Point °C (ISO 3016)	-30
Rust, Salt, Water (ASTM D 665B)	Pass
Oxidation Control Tests	
a) TOST, hrs	2,000+
b) RPVOT, mins.	300

SHELL MORLINA S2 B

INDUSTRIAL BEARING AND CIRCULATING OILS

PREVIOUSLY SHELL MORLINA

DESIGNED TO MEET CHALLENGES

Shell Morlina S2 B oils are high performance oils designed to provide outstanding oxidation and water separation protection for most general industrial bearing and circulating oil system applications and certain other industrial applications which do not require oils with extreme pressure (EP) properties.

PERFORMANCE FEATURES

CONSISTENT PERFORMANCE

- Shell Morlina S2 B oils are formulated with a well proven rust and oxidation inhibitor additive package that helps provide consistent performance and protection throughout the maintenance interval.

RELIABLE WEAR AND CORROSION PROTECTION

SHELL MORLINA S2 B OILS HELP PROLONG THE LIFE OF BEARINGS AND CIRCULATING SYSTEMS THROUGH:

- Excellent water separation characteristics that helps ensure that critical oil films are retained between highly loaded parts.
- Good air release characteristics to minimise cavitation and associated damage to circulating pumps.
- Helps protect against corrosion, oxidation, and emulsion formation, even in the presence of water.

MAINTAINING SYSTEM EFFICIENCY

- Shell Morlina S2 B oils are blended with high quality, solvent refined base oils that promote good water separation and air release to ensure the efficient lubrication of the machines and systems.

APPLICATIONS

MACHINE CIRCULATION SYSTEMS

OIL LUBRICATED BEARINGS

- Suitable for most plain and rolling element bearings and general industrial applications.

ROLL-NECK BEARINGS

ENCLOSED INDUSTRIAL GEAR SYSTEMS

- Low or moderately loaded enclosed gears where EP performance is not required.

SPECIFICATIONS, APPROVALS AND RECOMMENDATIONS

MEETS THE REQUIREMENTS OF:

- Morgan Morgoil® Lubricant Specification New Oil (Rev. 1.1)
- Danieli Standard Oil 6.12424.9F
- DIN 51517-1 – type C, 51517-2 – type CL.

PAINT COMPATIBILITY

- Shell Morlina S2 B oils are compatible with seal materials and paints normally specified for use with mineral oils.

Morgoil® is a registered trademark of the Morgan Construction Company.

TYPICAL PHYSICAL CHARACTERISTICS

CHARACTERISTICS	100	150	220	320
Kinematic Viscosity (ASTM D 445)				
@ 40°C mm ² /s	100	150	220	320
@ 100°C mm ² /s	11.2	15	18.3	25
Density @ 15°C kg/m ³ (ISO 12185)	881	887	891	897
Viscosity Index (ISO 2909)	97	95	92	96
Flash Point °C (COC) (ISO 2592)	250	262	280	282
Pour Point °C (ISO 3016)	-18	-15	-15	-12

SHELL MORLINA S4 B

ADVANCED BEARING AND CIRCULATING OILS

PREVIOUSLY SHELL OMALA RL

DESIGNED TO MEET CHALLENGES



Shell Morlina S4 B oils are high performance synthetic bearing and circulation lubricants, based on high performance base fluids. It offers outstanding lubrication performance under severe operating conditions, including improved energy efficiency and long service life even in severe operating conditions.

PERFORMANCE FEATURES

LONG OIL LIFE-MAINTENANCE SAVING

- The use of highly stable synthetic base oils in conjunction with a robust rust and oxidation inhibitor package helps provide excellent oxidation and thermal stability. This provides Shell Morlina S4 B with extending maintenance capability compared to conventional oils.
- In addition it helps resist the formation of harmful products of oxidation at high operating temperatures, to help maintain system cleanliness and therefore reliability of the equipment.

EXCELLENT WEAR AND CORROSION PROTECTION

- Shell Morlina S4 B has been formulated to provide excellent anti-wear performance and provides high levels of wear protection for plain and rolling element bearings and moderately loaded gearboxes, compared to mineral oil-based products. This helps provide superior gear and bearing component life.
- In addition it also provides outstanding rust and corrosion protection of all metal surfaces.

ENHANCING SYSTEM EFFICIENCY

- Shell Morlina S4 B can help improve the efficiency of lubrication in bearing and circulating systems. The superior low temperature performance and reduced change in viscosity with increase in temperature in comparison to mineral oil-based. Products provide better lubrication at low start-up temperatures and the opportunity for energy.
- Savings through reduced pumping and flow losses during normal operating conditions.
- Rapid water shedding and air release properties further enhance the efficiency of the lubrication system by helping maintain critical oil films between loaded components.

APPLICATIONS

SEVERE OPERATING CONDITIONS

- Shell Morlina S4 B is recommended for systems including moderately loaded gearboxes, operating under severe conditions such as low or high temperatures or with wide temperature variations.

LUBRICATED FOR LIFE SYSTEMS

- The long oil life of Shell Morlina S4 B makes it suitable for use in certain 'lubricated-for-life' systems.

BEARING AND CIRCULATING OIL SYSTEMS

- Suitable for use in systems containing plain or rolling element bearings, including those highly loaded bearings found in cement or quarrying applications.

SPECIFICATIONS, APPROVALS AND RECOMMENDATIONS

MEETS THE REQUIREMENTS OF:

- ISO 12925-1 Type CKS specification
- Alfa Laval Group D gearbox applications
- Aerzen Maschinenfabrik GmbH Blower applications
- Baltimore Aircoil Gear Boxes
- Cincinnati Machine Various P applications
- David Brown Table H applications
- Emerson Power Transmission
- GEA Westfalia Separator GmbH
- Renold Gears (various applications)
- Sharpe E-series worm gear reducers
- Winsmith (Peerless-Winsmith Inc) Worm gear reducer.

SEAL AND PAINT COMPATIBILITY

- Shell Morlina S4 B is compatible with all seal materials and paints normally specified for use with mineral oils.

CHANGE OVER PROCEDURE

- Shell Morlina S4 B is compatible with petroleum mineral oils and no special change-over procedure is necessary. However, to realise the full benefits, it should not be mixed with other oils.
- It is also advisable to ensure that oil systems are clean and free from contamination to optimise potential service life.

TYPICAL PHYSICAL CHARACTERISTICS

CHARACTERISTICS	150	220
Kinematic Viscosity (ISO 3104) @ 40°C mm ² /s	150	220
@ 100°C mm ² /s	19.8	25.9
Viscosity Index (ISO 2909)	149	149
Density @ 15°C kg/m ³ (ISO 12185)	846	848
Flash Point °C (COC) (ISO 2592)	236	240
Pour Point °C (ISO 3016)	-54	-48
Emulsion Test, mins. (ASTM D 1401)	15	15
Foam Test, Seq II (ml foam at 0/10 mins.) (ASTM D 892)	0/0	0/0
FZG Load Carrying Test DIN 51354-2 A/8.3/90 – Failure load stage	>12	>12

SHELL DIALA S2 ZU-I

UNINHIBITED ELECTRICAL INSULATING OIL

RECOMMENDED REPLACEMENT FOR SHELL DIALA B



DESIGNED TO MEET CHALLENGES

Shell Diala S2 ZU-I is an uninhibited electrical insulating oil manufactured from highly refined mineral oils. It offers good dielectric properties, good oxidation stability and provides efficient heat transfer even at low temperatures.

Shell Diala S2 ZU-I meets both the established and the new industry copper corrosion tests.

PERFORMANCE FEATURES

EXTENDED OIL LIFE

- Shell Diala S2 ZU-I offers inherent natural resistance to oil degradation through oxidation.

SYSTEM EFFICIENCY

- The good low temperature properties of the oil ensures proper heat transfer inside the transformer, even from low starting temperatures.

TRANSFORMER PROTECTION

- Shell Diala S2 ZU-I is non-corrosive towards copper, with no need for passivation. Shell Diala S2 ZU-I meets all relevant tests on copper corrosion, namely the established DIN 51353 (Silver Strip Test) and ASTM D1275, and also the latest more severe tests: IEC 62535 and ASTM D1275B.

APPLICATIONS

TRANSFORMERS

- Electrical insulating oil for grid and industrial transformers.

ELECTRICAL EQUIPMENT

- Components such as rectifiers, circuit breakers and switchgears.

SPECIFICATIONS, APPROVALS AND RECOMMENDATIONS

- IEC: 60296 (2003) Table 2 Transformer Oil (U): uninhibited.

STORAGE PRECAUTIONS

- The critical electrical properties of Shell Diala S2 ZU-I are easily compromised by trace contamination with foreign material. Typically encountered contaminants include moisture, particles, fibres and surfactants. Therefore, it is imperative that electrical insulating oils be kept clean and dry.
- It is strongly recommended that storage containers be dedicated for electrical service and include airtight seals. It is further recommended that electrical insulating oils be stored indoors in climate-controlled environments.

TYPICAL PHYSICAL CHARACTERISTICS

CHARACTERISTICS		
Appearance (IEC 60296)	Clear, free from sediment and suspended matters	Complies
Density (ISO 3675) @ 15°C kg/m ³	–	884
@ 20°C kg/m ³	Max. 895	881
Kinematic Viscosity (ISO 3104) @ 40°C mm ² /s	Guaranteed Max. 11.2 (IEC 60296 = Max. 12)	9,4
@ –30°C mm ² /s	Max. 1.800	940
Flash Point °C (PM) (ISO 2719/ASTM D93)	Min. 135	144
Pour Point °C (ISO 3016)	Max. –40	–57
Neutralisation Value mg KOH/g (IEC 62021-1)	Max. 0,01	<0,01
Corrosive Sulphur (DIN 51353), (IEC 62535) (ASTM D 1275 B)	Not corrosive –	Not corrosive Not corrosive
Breakdown Voltage kV (IEC 60156) Untreated	Min. 30	>30
After treatment	Min. 70	>70
Dielectric Dissipation Factor (DDF) @ 90°C (IEC 60247)	Max. 0.005	0.002
Oxidation Stability (164h/120°C) (IEC 61125 C) Total acidity mg KOH/g	Max. 1.2	0.9
Sludge %m	Max. 0.8	0.3
DDF @ 90°C (IEC 60247)	Max. 0.5	0.1

SHELL DIALA S3 ZX-I DRIED

PREMIUM INHIBITED ELECTRICAL INSULATING OIL



DESIGNED TO MEET CHALLENGES

Shell Diala S3 ZX-I Dried is a premium inhibited electrical insulating oil manufactured from specially refined mineral oils with an ultra-low sulphur content. It offers very high oxidation stability and excellent dielectric and low temperature properties. Shell Diala S3 ZX-I Dried is dried to achieve a higher breakdown voltage than required by standard industry norms.

Shell Diala S3 ZX-I Dried meets both the established and new industry copper corrosion tests.

PERFORMANCE FEATURES AND BENEFITS

EXTENDED OIL LIFE

- Shell Diala S3 ZX-I Dried is a fully inhibited oil giving outstanding oxidation performance and an extended oil life. Shell Diala S3 ZX-I Dried is also suitable for use in highly loaded applications.

TRANSFORMER PROTECTION

- Shell Diala S3 ZX-I Dried is manufactured from an ultra low sulphur base oil, making it intrinsically non-corrosive towards copper, without the need for passivation.

SYSTEM EFFICIENCY

- The good low temperature properties of the oil ensure proper heat transfer inside the transformer, even from very low starting temperatures.

Shell Diala S3 ZX-I Dried is specially dried and handled to achieve a low water content and retain a high breakdown voltage at point of delivery. This enables it to be used in many applications without further treatment.

APPLICATIONS

TRANSFORMERS

- All Power transformer types and applications (e.g. generator transformers, shunt reactors, distribution transformers).

ELECTRICAL EQUIPMENT

- Components such as rectifiers, circuit breakers and switchgear.

SPECIFICATIONS, APPROVALS AND RECOMMENDATIONS

- IEC 60296 (Edition 4.0 2012-02): Table 2
- Transformer Oil (I) (Inhibited oil)
- Section 7.1 ("Higher oxidation stability")
- Baader oxidation test of (obsolete).

TYPICAL PHYSICAL CHARACTERISTICS

CHARACTERISTICS		
Appearance (IEC 60296)	Clear, free from sediment and suspended matters	Complies
Density (ISO 3675) @ 15°C kg/m ³	–	881
@ 20°C kg/m ³	Max. 895	878
Kinematic Viscosity (ISO 3104) @ 40°C mm ² /s	Max. 12	8.0
@ –30°C mm ² /s	Guaranteed max. 800 (IEC 60296=Max. 1.800)	720
Flash Point °C (PM) (ISO 2719)	Min. 135	138
Pour Point °C (ISO 3016)	Guaranteed max. -45 (IEC 60296=Max. -40)	–60
Neutralisation Value mg KOH/g (IEC 62021-1)	Max. 0.01	<0.01
Corrosive Sulphur (DIN 51353), (IEC 62535), (ASTM D1275 B)	Not corrosive –	Not corrosive Not corrosive
Breakdown Voltage kV (IEC 60156)		
As Delivered	Min. 30	>30
After treatment	Min. 70	>70
Dielectric Dissipation Factor (DDF) @ 90°C (IEC 60247)	Max. 0.005	0.001
Oxidation Stability (500h/120°C) (IEC 61125 C)		
Total acidity mg/KOH/g	Max. 0.3	0.02
Sludge %m	Max. 0.05	0.01
DDF @ 90°C	Max. 0.05	0.005
Oxidation Stability Baader (28d/110°C) (DIN 51554)		
Neutralisation value mg/KOH/g	–	<0.03
Sludge content %m	–	<0.006
DDF @ 90°C	–	0.005

SHELL MYSELLA S3 N*

PREMIUM QUALITY STATIONARY GAS ENGINE OIL

PREVIOUSLY SHELL MYSELLA OIL LA
*as from April 2013

DESIGNED TO MEET CHALLENGES

Shell Mysella S3 N is a premium quality oil blended for use in highly-rated, spark-ignition engines which require a 'low ash' oil. It satisfies the new generation of stationary gas engines designed to meet the emerging legislation limiting emissions of NO_x, and those which employ the latest 'lean' or 'clean' burn technology.

PERFORMANCE FEATURES

EXCELLENT PISTON AND ENGINE CLEANLINESS

- Ensures long and efficient engine operation.

VERY HIGH OXIDATION AND NITRATION RESISTANCE

- Helps prolong oil life by resisting viscosity increase and the formation of harmful acids, especially in demanding cogeneration (CHP) applications.

OPTIMISED LEVEL OF 'ASH' COMPONENTS AND ALKALINITY RESERVE

- High levels of ash in the oil can lead to hard deposits in gas engines. Shell Mysella S3 N is formulated to give best possible neutralisation of acids and provide corrosion protection also at a 'low ash' (<0.5%) level.

LOW PHOSPHORUS LEVEL

- With a maximum phosphorus content of 300 ppm Shell Mysella S3 N is compatible with engines equipped with emission catalysts.

APPLICATIONS

SPARK-IGNITED GAS ENGINES FUELLED BY NATURAL GAS

- Although Shell Mysella S3 N is mainly developed to be used in natural gas applications it can also be used in engines fuelled by sour gases when a low ash oil is required.

SPECIFICATIONS, APPROVALS AND RECOMMENDATIONS

- API CD.

MEETS THE REQUIREMENTS FOR:

- Stationary gas engines.
- Caterpillar

APPROVED BY:

- Cummins
- MWM Deutz*
- Jenbacher* (with 3-way catalyst)
- MTU*
- Ruston Diesels
- Wärtsilä*.

* SAE 40 only

IS SUITABLE FOR:

- A number of other engine types, where a 'low ash' oil is required.

TYPICAL PHYSICAL CHARACTERISTICS

CHARACTERISTICS	40
Kinematic Viscosity (ASTM D 445) @ 40°C mm ² /s	139
@ 100°C mm ² /s	14
Density @ 15°C kg/m ³ (ASTM D 4052)	892
Flash Point °C (COC) (ISO 2592)	230
Pour Point °C (ISO 3016)	-18
Total Base Number mg KOH/g (ISO 3771)	5
Sulphated Ash % wt (ISO 3987)	0.45
Phosphorus max. ppm (ASTM D 4047)	300

SHELL MYSELLA S3 S*

PREMIUM QUALITY STATIONARY GAS ENGINE OIL

PREVIOUSLY SHELL MYSELLA OIL MA
*as from April 2013



DESIGNED TO MEET CHALLENGES

Shell Mysella S3 S is a premium quality oil blended for use in highly-rated spark ignition and dual-fuel four-stroke engines which require a 'medium ash' oil, or where 'sour gas' is in use. It satisfies the new generation of stationary gas engines designed to meet the emerging legislation limiting emissions of NO_x, and those which employ the latest 'lean' or 'clean' burn technology.

PERFORMANCE FEATURES

EXCELLENT PISTON AND ENGINE CLEANLINESS

- Long and efficient engine operation.

ENHANCED DIESEL DETERGENCY FOR DUAL-FUEL ENGINES

- Helps keep engines using diesel fuel clean.

VERY HIGH OXIDATION AND NITRATION RESISTANCE

- Helps prolong oil life by resisting viscosity increase and the formation of harmful acids, especially in demanding cogeneration (CHP) applications.

OPTIMISED LEVEL OF 'ASH' COMPONENTS

- Helps prolong the life of valves, in engines which prefer a medium ash oil.

RESERVE ALKALINITY

- The high level of TBN (Total Base Number) neutralises acids and provides corrosion protection, even when 'sour' gases are in use.

LOW PHOSPHORUS LEVEL

- With a maximum phosphorus content of 300 ppm Shell Mysella S3 S is compatible with engines equipped with emission catalysts.

APPLICATIONS

SPARK-IGNITED GAS ENGINES FUELLED BY NATURAL OR SO CALLED 'SOUR' GAS

- Shell Mysella S3 S is developed for engines and applications requiring a 'medium ash' oil. It is suitable for use with all types of gases; natural (sweet) gas as well as so called sour gases like landfill and sewage gas.

'DUAL-FUEL' GAS ENGINES IGNITED BY DIESEL PILOT FUEL

SPECIFICATIONS, APPROVALS AND RECOMMENDATIONS

- API CD.

APPROVED BY:

- Dorman
- Jenbacher (except 3-way catalyst, see Mysella LA)
- M.D.E. (natural gas/propane)
- Ruston Diesels
- Waukesha (including cogeneration application).

TYPICAL PHYSICAL CHARACTERISTICS

CHARACTERISTICS	40
Kinematic Viscosity (ASTM D 445) @ 40°C mm ² /s	139
@ 100°C mm ² /s	14
Density @ 15°C kg/m ³ (ASTM D 4052)	894
Flash Point °C (ASTM D 93) (ISO 2592)	230
Pour Point °C (ISO 3016)	-18
Total Base Number mg KOH/g (ISO 3771)	8.5
Sulphated Ash % wt (ISO 3987)	0.9
Phosphorus max. ppm (ASTM D 4047)	300

SHELL SHELL MYSELLA S5 N*

LONG LIFE STATIONARY GAS ENGINE OIL

PREVIOUSLY SHELL MYSELLA OIL XL

*as from April 2013

DESIGNED TO MEET CHALLENGES

Shell Mysella S5 N is a high performance quality oil blended for use in highly-rated, 4-stroke, spark-ignition engines which require a 'low ash' oil.

Shell Mysella S5 N satisfies the new generation of stationary gas engines designed to meet the emerging legislation limiting emissions of NO_x, and those which employ the latest 'lean' or 'clean' burn technology. Shell Mysella Oil XL is specially developed to provide extended drain intervals in those natural gas engines where oil life is a limiting operational factor.

PERFORMANCE FEATURES

STEP CHANGE IN OIL DRAIN INTERVAL

- Helps to significantly prolong oil life relative to previous generation gas engine oils by resisting oxidation and nitration, viscosity increase and the formation of harmful acids, especially in demanding cogeneration (CHP) applications. (When used with landfill or biogases, oil life will be dependent on the level of contaminants in the gas.)

EXCELLENT PISTON CLEANLINESS

- Superior control of deposits in advanced designs where previous products are not satisfactory.

OPTIMISED LEVEL OF 'ASH' COMPONENTS

- Helps prolong the life of valves and spark plugs.

LOW PHOSPHORUS LEVEL

- Compatible with engines equipped with emission catalysts.

APPLICATIONS

- Spark-ignited gas engines fuelled by natural gas, especially those creating high oil stress.
- May also be used for landfill and biogases.

SPECIFICATIONS, APPROVALS AND RECOMMENDATIONS

- API CF
- Caterpillar.

APPROVED BY:

- MWM Deutz
- Wärtsilä
- Rolls Royce Bergen K-G1, K-G2, K-G3, K-G4 and B series
- MAN
- MDE
- Waukesha cogen applications.

IS SUITABLE FOR:

- Engine types where a 'low ash' oil is required.

TYPICAL PHYSICAL CHARACTERISTICS

CHARACTERISTICS	40
Kinematic Viscosity	
@ 40°C mm ² /s	128
@ 100°C mm ² /s	14
Density @ 15°C kg/m ³	890
Flash Point °C (COC)	240
Pour Point °C	-18
Total Base Number mg KOH/g	4.5
Sulphated Ash % wt	0.48
Phosphorus max. ppm	300

SHELL OMALA

INDUSTRIAL GEAR OILS

The Shell Omala range of industrial gear oils is designed to help make it easy for equipment operators to select the Shell oil that will best deliver value to their operations through enhanced wear protection, long oil life and high system efficiency.

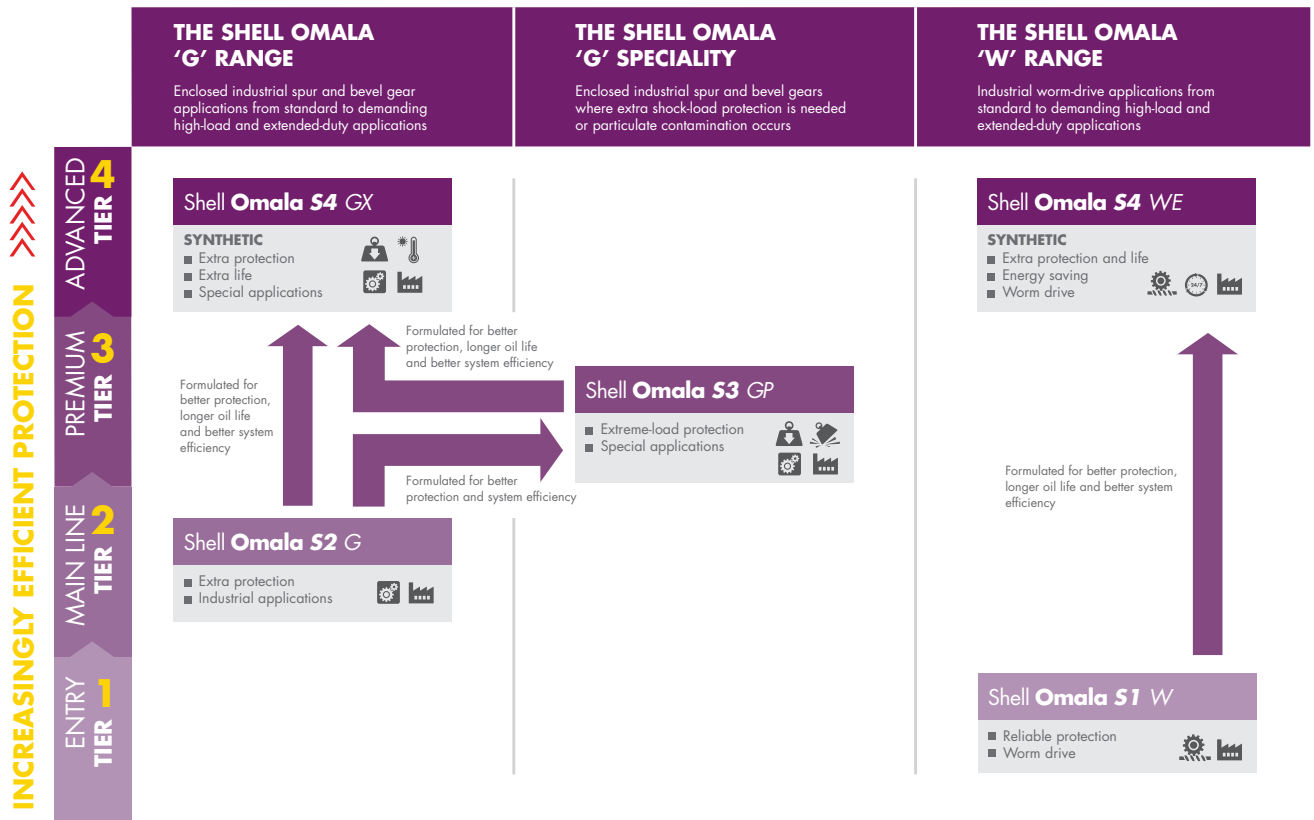

PRODUCT-NAME SUFFIX KEY

- E** = Energy saving, high efficiency
- G** = Gears – spur and helical
- P** = Extreme/high pressure
- W** = Worm drive
- X** = Extra/extreme performance

APPLICATION ICON KEY

- Extreme load
- High temperature
- Enclosed gear
- Factory/machine application
- Worm drive
- Long life
- Shock load

SHELL OMALA F

PREMIUM QUALITY INDUSTRIAL GEAR OIL

DESIGNED TO MEET CHALLENGES

Shell Omala F are premium quality, extreme-pressure oils designed, primarily, for the lubrication of heavy-duty industrial gears. Their high load carrying capacity and anti-friction characteristics combine to offer superior performance in gears and other industrial applications. They are formulated using high viscosity index, solvent refined, bases and incorporate a special sulphur-phosphorus additive to provide an extreme pressure performance significantly better than that provided by leaded gear oils. Shell Omala F are formally approved by Flender AG.

PERFORMANCE FEATURES

EXCELLENT LOAD CARRYING AND ANTI-FRICTION CHARACTERISTICS

- Helps to reduce gear tooth and bearing wear on both steel and bronze components.

OUTSTANDING OXIDATION AND THERMAL STABILITY

- Withstands high thermal loading and helps resist the formation of sludge and other harmful products of oxidation. Extended life, even with bulk temperatures up to 100°C in certain applications.

EFFECTIVE CORROSION INHIBITION

- Protects both steel and bronze components, even in the presence of contamination by water and solids.

WIDE RANGE OF VISCOSITIES

- Caters for the most varied and arduous industrial applications.

RESISTANT TO MICRO-PITTING

- Standard setting anti micro-pitting performance to reduce the risk of premature failure through surface distress.

WATER SHEDDING PROPERTIES

- Shell Omala F has excellent water separation properties. Excess water can be drained easily from lubrication systems. (Water can greatly accelerate surface fatigue on gears and bearings as well as promoting ferrous corrosion on internal surfaces. Water contamination should be avoided or removed as quickly as possible after the occurrence).

APPLICATIONS

- Steel gear transmissions
- Industrial gear drives where a full EP performance is required
- Bearings.

CIRCULATING AND SPLASH LUBRICATED SYSTEMS

- Shell Omala F should not be used for automotive hypoid gears. The appropriate Shell Spirax should be used for this purpose.

SPECIFICATIONS, APPROVALS AND RECOMMENDATIONS

APPROVED AGAINST FLENDER AG'S REQUIREMENTS OF 22/1/96 WHICH INCLUDE:

- Sufficient oxidation stability for a lifetime of 10,000 hours or two years at 80°C.
- A load stage 12 pass in the FZG double speed test (DIN 51354 Part 2).
- A pass in the FVA-54/II micro pitting (grey staining) test at load stage 10 at 90°C plus.
- Flender Foam Test.

COMPATIBILITY WITH:

- Internal gearbox paints, solid seals, compatibility with liquid seals.

TYPICAL PHYSICAL CHARACTERISTICS

CHARACTERISTICS	320	460
Kinematic Viscosity (IP 71)		
@ 40°C mm ² /s	320	460
@ 100°C mm ² /s	25.0	30.8
Viscosity Index (IP 226)	100	97
Density @ 15°C kg/m ³ (IP 365)	903	904
Flash Point °C (PMCC) (IP 34)	202	204
Pour Point °C (IP 15)	-18	-9

SHELL OMALA S1 W

INDUSTRIAL GEAR OILS

PREVIOUSLY SHELL VALVATA J

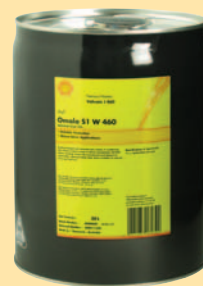
DESIGNED TO MEET CHALLENGES

Shell Omala S1 W oils are quality refined, high viscosity mineral oils compounded with a small percentage of fatty oils. They are particularly suitable for the lubrication of low speed enclosed gears and worm drive application. They are also suitable for the lubrication of high temperature, high pressure steam cylinders.

PERFORMANCE FEATURES**CONSISTENT PERFORMANCE**

- Shell Omala S1 W possesses low volatility and a natural resistance to the formation of gummy or carbonaceous deposits in high temperature conditions to give consistent performance through the lubrication maintenance intervals.

WEAR PROTECTION

- Provides a reliable oil film under low speed operation such as worm gear drives.

APPLICATIONS**ENCLOSED INDUSTRIAL WORM GEAR SYSTEMS**

- Shell Omala S1 W may be used to advantage in worm gears prone to suffer extensive wear and to reduce the bulk oil temperature. Typical examples are gears running at low speed under stop-start conditions.

STEAM CYLINDER LUBRICATION

- Suitable for steam cylinder applications working under high temperature and high pressure conditions.
- For highly-loaded worm drives Shell Omala S4 WE is recommended.
- For industrial enclosed spur and helical gear systems the Shell Omala 'G' series is recommended.
- For automotive hypoid gears, the appropriate Shell Spirax Oil should be used.

SPECIFICATIONS, APPROVALS AND RECOMMENDATIONS**MEETS THE SPECIFICATIONS OF:**

- AGMA 9005-EO2 (CP).

TYPICAL PHYSICAL CHARACTERISTICS

CHARACTERISTICS	460
Kinematic Viscosity (ISO 3104) @ 40°C mm ² /s	460
@ 100°C mm ² /s	31.5
Viscosity Index (ISO 2909)	98
Density @ 15°C kg/m ³ (ISO 12185)	887
Flash Point °C (PMCC) (ISO 2592)	318
Pour Point °C (ISO 3016)	-6

SHELL OMALA S2 G

INDUSTRIAL GEAR OILS

PREVIOUSLY SHELL OMALA

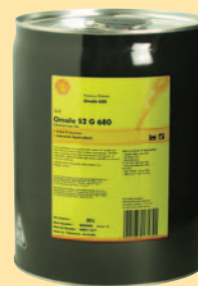

DESIGNED TO MEET CHALLENGES

Shell Omala S2 G oils are high quality extreme-pressure oils designed primarily for the lubrication of heavy-duty industrial gears. Their high load carrying capacity and anti-friction characteristics combine to offer superior performance in gears.

PERFORMANCE FEATURES

LONG OIL LIFE – MAINTENANCE SAVING

- Shell Omala S2 G oils are formulated to resist thermal and chemical breakdown throughout the maintenance interval. They withstand high thermal loading and help resist the formation of sludge to provide extended oil life capability, even with bulk oil temperatures of up to 100°C in certain applications.

EXCELLENT WEAR AND CORROSION PROTECTION

- Excellent load carrying capacity, helps to reduce gear tooth and bearing wear on both steel and bronze components.
- Shell Omala S2 G has excellent corrosion protection, protecting both steel and bronze components, even in the presence of contamination by water and solids.

MAINTAINING SYSTEM EFFICIENCY

- Shell Omala S2 G oils have excellent water separation properties, such that excess water can be drained easily from lubrication systems to help extend the life of the gears and ensure efficient lubrication of the contact areas.
- Water can greatly accelerate surface fatigue with gears and bearings as well as promoting ferrous corrosion on internal surfaces. Water contamination should therefore be avoided or removed as quickly as possible after the occurrence.

APPLICATIONS

ENCLOSED INDUSTRIAL GEAR SYSTEMS

- Shell Omala S2 G oils are formulated using an effective sulphur-phosphorus additive system to provide an extreme pressure performance which allow trouble-free application in most enclosed industrial gearboxes using steel spur and helical gears.

HIGHLY LOADED GEARS

- Shell Omala S2 G oils have an effective full extreme pressure (EP) additive system allowing them to be used in highly-loaded gear systems.

OTHER APPLICATIONS

- Shell Omala S2 G oils are suitable for lubrication of bearings and other components in circulating and splash-lubricated systems.
- For highly-loaded worm drives the Shell Omala S4 WE series oils are recommended. For automotive hypoid gears, the appropriate Shell Spirax Oil should be used.

SPECIFICATIONS, APPROVALS AND RECOMMENDATIONS

MEETS THE REQUIREMENTS OF:

- ISO: 12925-1 Type CKD
- DIN: 51517- Part 3 (CLP)
- AGMA: 9005- EO2 (EP)
- US Steel 224
- David Brown: S1.53.101,102,103,104
- Cincinatti Machine: P34,35,59,63, 74, 76-78.

TYPICAL PHYSICAL CHARACTERISTICS

CHARACTERISTICS	68	100	150	220	320	460	680	1000
Kinematic Viscosity (ISO 3104)								
@ 40°C mm ² /s	68	100	150	220	320	460	680	1000
@ 100°C mm ² /s	8.7	11.4	15.0	19.4	25.0	30.8	38.0	45.4
Viscosity Index (ISO 2909)	99	100	100	100	100	97	92	85
Density @ 15°C kg/m ³ (ISO 12185)	887	891	897	899	903	904	912	931
Flash Point °C (PMCC) (ISO 2592)	236	240	240	240	255	260	272	290
Pour Point °C (ISO 3016)	-24	-24	-24	-18	-15	-12	-9	-6

SHELL OMALA S3 GP

SPECIAL APPLICATION INDUSTRIAL GEAR OIL

RECOMMENDED REPLACEMENT FOR SHELL MINE GEAR 1500

DESIGNED TO MEET CHALLENGES



Shell Omala S3 GP oil is a specialist 'problem solving' lubricant developed to lubricate industrial gearboxes subject to extremely high and heavily shock loaded operations such as those found in steel, cement, mining and quarrying industries. They are formulated for use where ultra-high levels of extreme-pressure performance are required.

PERFORMANCE BENEFITS

LONG OIL LIFE

- Shell Omala S3 GP oil is formulated to resist thermal and chemical breakdown throughout the maintenance interval. They help resist the formation of sludge to provide good oil life capability even at temperatures up to 100°C.

EXCELLENT WEAR AND CORROSION PROTECTION

- Shell Omala S3 GP oil is formulated with high levels of extreme pressure and anti-wear additives properties to help ensure optimal gear and bearing protection even under the severest operating conditions.
- Shell Omala S3 GP has excellent corrosion protection, protecting steel components, even in the presence of contamination by water and solids.

MAINTAINING SYSTEM EFFICIENCY

- Shell Omala S3 GP oil has excellent water separation properties, such that excess water can be drained easily from lubrication systems to help maintain the integrity of critical oil films and extend the life of the gears.

APPLICATIONS

- Highly loaded gears.
- Shell Omala S3 GP oil is designed for use in enclosed industrial gear systems subject to severe operating conditions including high shock loading applications.

WORN OR DAMAGED GEARS

- The oil can be used in older gear systems that may be damaged or misaligned. The extreme pressure performance provides additional protection in such applications.

OTHER APPLICATIONS

- Shell Omala S3 GP oil is suitable for lubrication of bearings and other components in circulating and splash-lubricated systems.
- For normal load applications the other Shell Omala 'G' series oils are recommended.
- For automotive hypoid gears, the appropriate Shell Spirax Oil should be used.

SPECIFICATIONS, APPROVALS AND RECOMMENDATIONS

MEETS:

- ISO 12925-1 Type CKD, except ISO 680 and 1500
- ANSI/AGMA 9005-E02 (EP)
- US Steel 224
- DIN 51517-3 (CLP), except ISO 680 and 1500
- David Brown S1.53.101E, except ISO 680 and 1500
- Arcelor Mittal FT163.

TYPICAL PHYSICAL CHARACTERISTICS

CHARACTERISTICS	1500
Viscosity (ISO 3104) @ 40°C mm ² /s	1500
@ 100°C mm ² /s	82.6
Viscosity Index (ISO 2909)	124
Flash Point °C (COC) (ISO 2592)	224
Pour Point °C (ISO 3016)	-21
Density @ 15°C kg/m ³ (ISO 12185)	902
FZG-Test Failure Load Stage ZG (A/16.6/90)	>12
Four Ball Weld Load kg	500

SHELL OMALA S4 WE

ADVANCED SYNTHETIC INDUSTRIAL GEAR OIL

PREVIOUSLY SHELL TIVELA S

DESIGNED TO MEET CHALLENGES

Shell Omala S4 WE is an advanced synthetic heavy-duty industrial worm drive gear oil formulated using specially selected polyalkylene glycol base fluids and additives. It offers outstanding lubrication performance under severe operating conditions, including improved energy efficiency, long service life and high resistance to micro-pitting.

PERFORMANCE FEATURES

LONG OIL LIFE – MAINTENANCE SAVING

- Shell Omala S4 WE is formulated to provide excellent oxidation and thermal stability, extending lubricant life and resisting the formation of harmful oxidation products at high operating temperatures. This helps maintain system cleanliness over extended maintenance intervals.
- This performance is recognised by Flender AG where a formal approval for 20,000 hours (four years) at 80°C (bulk oil temperature) usage has been granted.
- Shell Omala S4 WE offers the potential to extend service intervals significantly compared to conventional industrial gear oils.

EXCELLENT WEAR PROTECTION

- Shell Omala S4 WE is formulated to have excellent load carrying capacity providing long component life even under shock loading conditions. It also has a high resistance to micro-pitting. These features provide benefits over mineral oil-based products in terms of gear and bearing component life.

MAINTAINING SYSTEM EFFICIENCY

- Shell Omala S4 WE offers improved energy efficiency and lower operating temperatures in worm gear applications. Rig testing has shown efficiency improvements of up to 15% in comparison with mineral oil-based products and 11% over other synthetic hydrocarbon-based lubricants. These results have been confirmed by OEM testing and field experience.

APPLICATIONS

ENCLOSED INDUSTRIAL WORM GEAR SYSTEMS

- Recommended for industrial worm gear reduction systems operating under severe operating conditions, such as high load, very low or elevated temperatures and wide temperature variations.

EXTENDED LIFE SYSTEMS

- Shell Omala S4 WE is particularly recommended for certain systems where maintenance is infrequent or systems are inaccessible (e.g. yaw gears in wind turbine installations).

OTHER APPLICATIONS

- Shell Omala S4 WE oils are suitable for lubrication of bearings and other components in circulating and splash-lubricated systems.
- Shell Omala S4 WE is not recommended for the lubrication of components manufactured from aluminium or aluminium alloys.
- For highly-loaded spur and helical gears the Shell Omala 'G' series oils are recommended.

- For automotive hypoid gears, the appropriate Shell Spirax Oil should be used.

SEAL AND PAINT COMPATIBILITY

High quality epoxy paints are recommended, as polyalkylene glycols will tend to attack certain conventional paints. Shell Omala S4 WE has been found to be satisfactory with nitrile and Viton seal materials, although Viton seals are preferred.

CHANGE-OVER PROCEDURE

Shell Omala S4 WE contains polyalkylene glycols and is not compatible with mineral oils or most other synthetic lubricant types. Care should be taken when changing from such products to Shell Omala S4 WE. The system should be flushed with the minimum quantity of Shell Omala S4 WE, operating under no load and draining while warm. Ideally, seals exposed to mineral oils should also be replaced. Inspect the lubricant after a few days use. Ensure that oil systems are clean and free from contamination.

Shell Omala S4 WE is also not miscible with some other polyalkylene glycols, so caution is needed when topping-up. Generally the preference is to avoid mixtures by draining and refilling.

SPECIFICATIONS, APPROVALS AND RECOMMENDATIONS

MEETS:

- David Brown: S1.53.105 G
- ISO: 12925-1 Type CKE
- ANSI/AGMA: 9005-E02 (EP).

FULLY APPROVED BY:

- Flender: AG
- Bonfiglioli.

TYPICAL PHYSICAL CHARACTERISTICS

CHARACTERISTICS	150	220	320
Kinematic Viscosity (ISO 3104) @ 40°C mm ² /s	136	222	321
@ 100°C mm ² /s	22.5	34.4	52.7
Viscosity Index (ISO 2909)	188	203	230
Density @ 15°C kg/m ³ (ISO 12185)	1076	1074	1069
Flash Point °C (PMCC) (ISO 2592)	268	278	270
Pour Point °C (ISO 3016)	-42	-39	-39
FZG Load Carrying Test (DIN 51354-2 A/8.3/90) – Failure load stage	>12	>12	>12

SHELL OMALA S4 GX

ADVANCED SYNTHETIC INDUSTRIAL GEAR OIL

PREVIOUSLY SHELL OMALA HD

DESIGNED TO MEET CHALLENGES



Shell Omala S4 GX is an advanced synthetic heavy-duty industrial gear oil offering outstanding lubrication performance under severe operating conditions, including reduced friction, long service life and high resistance to micro-pitting for optimal gear protection.

PERFORMANCE FEATURES

LONG OIL LIFE – MAINTENANCE SAVING

- Shell Omala S4 GX is formulated using an advanced additive system in combination with specially selected synthetic base fluids to provide outstanding resistance to breakdown over long duration and/or high temperature operation.
- This performance is recognised by Flender AG where a formal approval for 20,000 hours (four years) at 80°C usage has been granted.
- Shell Omala S4 GX can operate successfully at bulk temperatures up to 120°C.
- Shell Omala S4 GX offers the potential to significantly extend service intervals compared to conventional industrial gear oils.

EXCELLENT WEAR AND CORROSION PROTECTION

- Shell Omala S4 GX is formulated to have excellent load carrying capacity and micro-pitting performance providing long component life even under shock loading conditions. These features provide benefits over mineral oil-based products in terms of gear and bearing component life.
- Shell Omala S4 GX also has excellent corrosion protection, even in the presence of contamination by water and solids.

MAINTAINING SYSTEM EFFICIENCY

- Shell Omala S4 GX can help maintain or enhance the efficiency of industrial gear systems through improved low temperature performance and lower friction in comparison to mineral oil-based products. This provides better lubrication at low start-up temperatures.
- Shell Omala S4 GX oils have excellent water separation properties, such that excess water can be drained easily from lubrication systems to help extend the life of the gears and ensure efficient lubrication of the contact areas.

APPLICATIONS

WIND TURBINES AND OTHER INACCESSIBLE INSTALLATIONS

- Shell Omala S4 GX is particularly recommended for certain systems where extra long life is required, maintenance is infrequent or systems are inaccessible.

ENCLOSED INDUSTRIAL GEAR SYSTEMS

- Recommended for industrial reduction gear systems operating under severe operating conditions, such as high load, very low or elevated temperatures and wide temperature variations.

OTHER APPLICATIONS

- Shell Omala S4 GX oils are suitable for lubrication of bearings and other components in circulating and splash-lubricated systems.
- For highly loaded worm drives the Shell Omala S4 WE series oils are recommended.
- For automotive hypoid gears, the appropriate Shell Spirax Oil should be used.

COMPATIBILITY AND MISCIBILITY

- Shell Omala S4 GX is compatible with all seal materials and paints normally specified for use with mineral oils.

SPECIFICATIONS, APPROVALS AND RECOMMENDATIONS

MEETS THE REQUIREMENTS OF:

- ISO 12925-1 Type CKD (except ISO 1000)
- ANSI/AGMA 9005-E02 (EP) (except ISO 1000)
- US Steel 224 (except ISO 1000)
- David Brown S1.53.106 (except ISO 1000)
- DIN 51517-3 (CLP) (except ISO 1000).

APPROVED BY:

- Flender AG.

APPROVED FOR WIND TURBINE GEARBOXES BY:

- Gamesa
- Dongfang Wind Turbines
- Dalian Heavy Industries
- Sinovel.

TYPICAL PHYSICAL CHARACTERISTICS

CHARACTERISTICS	220	320	460	680
Kinematic Viscosity (ISO 3104)				
@ 40°C mm ² /s	230	335	462.6	670.4
@ 100°C mm ² /s	30.0	40.0	50.0	64.9
Viscosity Index (ISO 2909)	160	159	170	169
Density @ 15°C kg/m ³ (ISO 12185)	881	883	879	881
Flash Point °C (COC) (ISO 2592)	250	252	264	256
Pour Point °C (ISO 3016)	-45	-42	-36	-33
FZG Load Carrying Test (DIN 51354-2 A/8.3/90 A/16, 6/90) – Failure load stage	>14	>14	>14	>14
Timken OK Load lbs (ASTM D 2782)	>85	>85	>85	>85

SHELL OMALA S4 WHEEL

ADVANCED SYNTHETIC INDUSTRIAL GEAR OIL

PREVIOUSLY SHELL HYPERIA S



DESIGNED TO MEET CHALLENGES

Shell Omala S4 Wheel is an advanced synthetic heavy-duty industrial gear oil offering outstanding lubrication performance under severe operating conditions, including improved energy efficiency and long service life. It is recommended specifically for use in General Electric Off-Highway Motorised Wheels fitted to load haul dump trucks used in mining applications.

PERFORMANCE FEATURES

EXCELLENT WEAR CORROSION PROTECTION

- Provides high levels of load carrying capacity even under shock loading conditions. This provides benefits over mineral oil-based products in terms of gear and bearing component life.
- Shell Omala S4 Wheel oil provide outstanding rust and corrosion protection on metal surfaces.

LONG OIL LIFE-MAINTENANCE SAVING

- Resists the formation of harmful products of oxidation at high operating temperatures, improving system cleanliness and therefore reliability of the equipment.
- Extended component and lubricant life offers the opportunity to extend service intervals and to help reduce maintenance and disposal costs.

ENHANCED SYSTEM EFFICIENCY

- Offers improved low temperature performance and reduced change in viscosity with increase in temperature in comparison to mineral oil-based products. This provides better lubrication at low start-up temperatures and the opportunity for energy savings by optimising the viscosity for normal operating conditions.
- Shell Omala S4 Wheel oils also have excellent water shedding and air release properties helping it maintain critical oil films and efficient lubricant.

APPLICATIONS

- Gearcases of General Electric motorised wheels fitted to load haul dump trucks used in mining applications.
- Enclosed industrial reduction gear systems operating under severe operating conditions, such as high load, very low or elevated temperatures and wide temperature variations.
- Plain and rolling element bearings.
- Oil circulation systems.
- For highly-loaded worm drives, Shell Omala S4 Wheel oil is recommended.
- For automotive hypoid gears, the appropriate Shell Spirax oil should be used.

SEAL AND PAINT COMPATIBILITY

Shell Omala S4 Wheel is compatible with all seal materials and paints normally specified for use with mineral oils.

SPECIFICATIONS, APPROVALS AND RECOMMENDATIONS

MEETS THE SPECIFICATIONS OF:

- David Brown S253.106H
- US Steel 224
- DIN 51517-3 (CLP).

APPROVED UNDER GE UNDER GEK-30375H AGAINST THE FOLLOWING:

- ISO 320 GE Specifications D50E 27C
- ISO 460 GE Specifications D50E 27D
- ISO 680 GE Specifications D50E 27E.

TYPICAL PHYSICAL CHARACTERISTICS

CHARACTERISTICS	680
Kinematic Viscosity (ISO 3104) @ 40°C mm ² /s	680
@ 100°C mm ² /s	61
Viscosity Index (ISO 2909)	157
Density @ 15°C kg/m ³ (ISO 12185)	860
Flash Point (ISO 2592) (PMCC) °C	274
Pour Point °C (ISO 3016)	-43
FZG Load Carrying Test (DIN 51354-2) A/8, 3/90 A/16, 6/90 – Failure load stage	>12
Timken OK Load lbs (ASTM D 2782)	>80

WANT TO INCREASE EFFICIENCY?

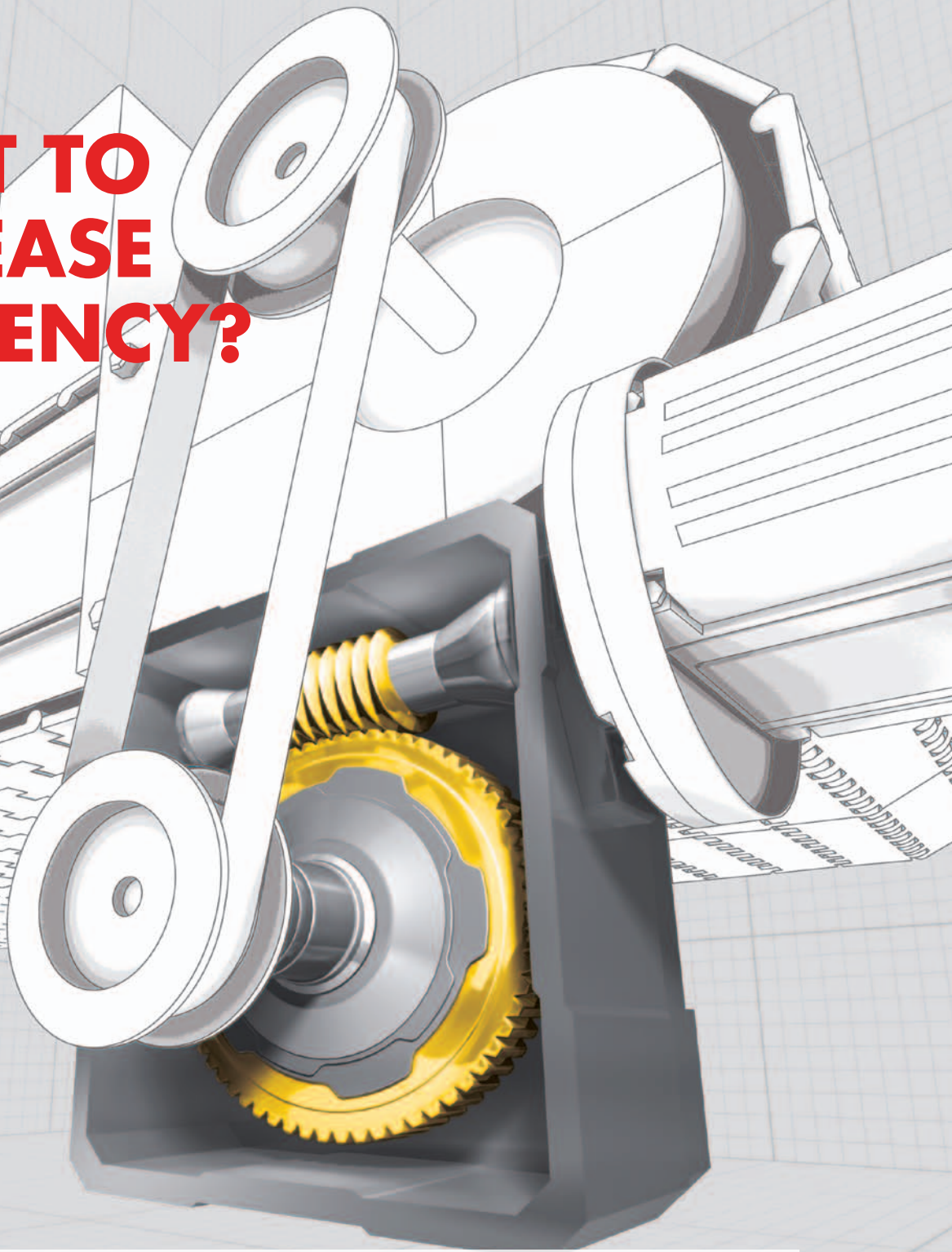

Shell Omala S4 WE

ADVANCED SYNTHETIC OIL FOR WORM GEARS

- Designed to help increase energy efficiency
- Excellent oil life and wear protection
- Increased productivity and reduced maintenance costs

Part of the Shell Omala industrial gear oil range
– designed to help you make the right choice

DESIGNED TO MEET CHALLENGES

SHELL DOBATEX GOLD

WATER BASED MULTI-PURPOSE CLEANING SOLUTION FOR TRUCK, CAR AND MARINE APPLICATIONS AND HEAVY-DUTY MINING EQUIPMENT



DESIGNED TO MEET CHALLENGES

Shell Dobatex Gold is a water based, multi-purpose cleaning detergent proven in a wide range of industrial and automotive applications including the heavier duty demands of mining equipment and fishing and trucking fleets through to routine janitorial cleaning.

PERFORMANCE FEATURES

Shell Dobatex Gold effectively removes dirt, grease and grime from all hard surfaces, even vertical ones, where its stable foaming action allows greater penetration and more thorough cleaning.

Shell Dobatex Gold will not promote rust or deteriorate paintwork, polished surfaces, metal or glass. It has strong colouring for ease of identification even at low dilution levels. It is formulated to provide good results even where water quality is poor.

EXCELLENT CLEANING PERFORMANCE

- Highly effective on a wide range of dirt, oils and grease in both soft or hard water.

MULTI-PURPOSE CONVENIENCE

- Shell Dobatex Gold is a versatile cleaner which can be used to reduce the number of detergents required on site.

REDUCED SAFETY CONCERNS

- Being water based, biodegradable, non flammable and free of odour, Shell Dobatex Gold is recommended for use in enclosed workshops or in underground maintenance stations where there is restricted ventilation.

ENVIRONMENTALLY RESPONSIBLE

- Biodegradable (AS 4351) and contains no hydrocarbon solvents or caustic alkalis.

AQIS APPROVED (CATEGORY 1, TYPE A)

- Shell Dobatex Gold carries full AQIS (Cat 1, Type A) approval status, which means that it is fully approved for use in general cleaning and janitorial applications in areas in contact with food preparation, such as general home and commercial kitchens, abattoirs, fishing and any other areas where incidental food contact is possible.

APPLICATIONS

Shell Dobatex Gold is highly adaptable to a wide range of cleaning requirements. One flexible product enables you to cut down on inventory, and with varying dilutions and application methods it is effective and safe for:

- Truck fleets, cars and small commercial vehicles
- Fishing fleets and marine leisure craft
- Heavy and light mining equipment
- Machinery and engine degreasing
- Routine and janitorial cleaning purposes such as:

- Flooring
- Commercial and home kitchens (including as a dishwashing fluid), cafeterias and bathrooms
- Food processing equipment
- Abattoirs, fishing cooperatives, commercial food preparation areas
- General purpose offices and office furniture cleaning solution
- Shell Dobatex Gold is a multi-purpose detergent and cleaning fluid.

SPECIFICATIONS, APPROVALS AND RECOMMENDATIONS

MEETS THE REQUIREMENTS OF:

- AQIS approved (Category 1, Type A)
- Ready biodegradability of a single organic substance or natural product when tested according to AS 4351 Part 2.

FLUID PREPARATION

SHELL DOBATEX GOLD MUST BE DILUTED WITH WATER BEFORE USE, EITHER MANUALLY OR WITH AUTOMATED DOSING EQUIPMENT. RECOMMENDED DILUTIONS ARE:

- Degreasing or workshop floors 1:3 to 1:5
- Vehicle washing 1:10
- Janitorial and general cleaning 1:100

When practicable, Shell Dobatex Gold should be left on particularly greasy surfaces or equipment for a few minutes to ensure penetration, before removing and rinsing with water.

TYPICAL PHYSICAL CHARACTERISTICS

CHARACTERISTICS	
Appearance (Visual)	Gold fluid
pH	10

SHELL DOBATEX AQUA DEGREASER

A HIGH-PERFORMANCE, BIODEGRADABLE, WATER BASED DEGREASING AND CLEANING AGENT FOR MINING, AUTOMOTIVE AND INDUSTRIAL APPLICATIONS

DESIGNED TO MEET CHALLENGES

Shell Dobatex Aqua Degreaser is a water based degreasing product formulated specifically for the removal of oil and grease in demanding applications in the general engineering, automotive and mining/construction industries.

PERFORMANCE FEATURES

Shell Dobatex Aqua Degreaser is a water based, quick break formulation designed to perform exceptionally well for organic residue removal in water based degreasing applications in parts and equipment washing. Shell Dobatex Aqua Degreaser effectively removes greases and greasy dirt, without risk of equipment damage.

Unlike most conventional degreasers, where a thin layer of hydrocarbon tends to remain after cleaning, Shell Dobatex Aqua Degreaser leaves a completely non-greasy surface.

Being water based, Shell Dobatex Aqua Degreaser is a safer alternative to solvent degreasers, especially when used indoors or in confined spaces.

Shell Dobatex Aqua Degreaser is a particularly simple and effective biodegradable cleaner for nasty oil stains on driveway and workshop floors. Shell Dobatex Aqua Degreaser provides superior and cost-effective results.

Shell Dobatex Aqua Degreaser can be used effectively with poor quality water sources.

APPLICATIONS

SHELL DOBATEX AQUA DEGREASER HAS BEEN DESIGNED FOR THE EFFECTIVE REMOVAL OF GREASE AND OIL/DIRT RESIDUES FROM:

- Engineering parts and equipment
- Automotive workshops and parts cleaning
- Mining equipment
- Mechanical parts
- Factory and driveway floors where frequent oil stains may occur.

EXCELLENT CLEANING PERFORMANCE

- Highly effective on a wide range of oils, grease and grime.

REDUCED SAFETY CONCERNS

- Being water based, biodegradable, non-flammable and with a citrus odour, Dobatex Aqua Degreaser is recommended for use in enclosed workshops or underground mining applications.

QUICK BREAK

- The special feature of Shell Dobatex Aqua Degreaser is its ability to emulsify grease/oil/water, then rapidly form separate oil and water phases. This property allows for speedy and efficient separation in grease traps and interceptors, minimising waste issues.

NEUTRAL PH

- Neutral pH enables safer handling.

ENVIRONMENTALLY RESPONSIBLE

- Biodegradable to AS 4351 part 2 and contains no hydrocarbon solvents or caustic alkalis.

FLUID PREPARATION

SHELL DOBATEX AQUA DEGREASER MUST BE DILUTED WITH WATER BEFORE USE, EITHER MANUALLY OR WITH AUTOMATED DOSING EQUIPMENT. RECOMMENDED DILUTIONS ARE:

- Degreasing of very dirty equipment 1:3
- Degreasing of workshop floors etc. 1:5
- General degreasing or cleaning 1:10

Shell Dobatex Aqua Degreaser should be applied by spraying or soaking and left to penetrate for at least 10 minutes. Pressure wash or rinse thoroughly to remove all grease, dirt and detergent.

TYPICAL PHYSICAL CHARACTERISTICS

CHARACTERISTICS	
Appearance (Visual)	Clear pink liquid
pH (1% Solution)	6.5

SHELL DOBATEX PLATINUM

A BIODEGRADABLE WATER BASED QUICK BREAK DETERGENT FOR HEAVY-DUTY MINING AND INDUSTRIAL APPLICATIONS

DESIGNED TO MEET CHALLENGES

Shell Dobatex Platinum is a premium performance phosphorus-free detergent suitable for a wide range of heavy-duty applications, where management of waste water is a priority.

PERFORMANCE FEATURES

EXCELLENT CLEANING PERFORMANCE

- Shell Dobatex Platinum is highly effective on a wide range of dirt, oils and grease in both hard and soft water.

ENVIRONMENTALLY RESPONSIBLE

- Phosphorus-Free, Shell Dobatex Platinum can be used without contributing to algal blooms caused by excess phosphates. It is water based and biodegradable, containing no hydrocarbon solvents or caustic alkalis.

QUICK BREAK

- Shell Dobatex Platinum has a unique ability to emulsify grease/oil/water, then rapidly form separate oil and water phases, allowing for quick and efficient separation in grease traps and interceptors.

BALANCED STABILITY AND QUICK BREAK PERFORMANCE

- Shell Dobatex Platinum is uniquely formulated to provide the delicate balance in foaming stability which allows it to be used on all surfaces, even vertical ones, yet retain superior ability to separate quickly in interceptor pits into discrete oil and water layers.

MULTI-PURPOSE CONVENIENCE

- Providing top-tier performance, Shell Dobatex Platinum can be used to reduce the number of detergents used on site without compromise.

REDUCED SAFETY CONCERNS

- Being water based, biodegradable, nonflammable and free of odour, Shell Dobatex Platinum is recommended for use in underground maintenance stations where there is restricted ventilation.

APPLICATIONS

Shell Dobatex Platinum is a premium performance detergent suitable for a wide range of cleaning requirements, including heavy and light mining equipment, heavy truck fleets and machinery and engine degreasing.

Shell Dobatex Platinum is formulated to provide premium performance results even when the water quality is poor.

SPECIFICATIONS, APPROVALS AND RECOMMENDATIONS

MEETS THE REQUIREMENTS FOR:

- Ready biodegradability of a single organic substance or natural product, when tested according to AS 4351 Part 2.

FLUID PREPARATION

Shell Dobatex Platinum must be diluted with water before use, either manually or with automated dosing equipment. Recommended dilutions are:

- Degreasing or workshop floors 1:3 to 1:5
- Vehicle washing 1:10
- Janitorial and general cleaning 1:100

When practicable, Shell Dobatex Platinum should be left on particularly greasy surfaces or equipment for a few minutes to ensure penetration, before removing and rinsing with water.

TYPICAL PHYSICAL CHARACTERISTICS

CHARACTERISTICS	
Appearance (Visual)	Green liquid
pH (1% Solution)	8

SHELL REFRIGERATION OIL S2 FR-A

REFRIGERATOR COMPRESSOR LUBRICANT

PREVIOUSLY SHELL CLAVUS

DESIGNED TO MEET CHALLENGES

Shell Refrigeration Oil S2 FR-A is a low miscibility compressor lubricant intended for use in refrigeration compressors using ammonia refrigerant. It is formulated from specially refined paraffinic base oils in combination with additives selected to minimise system deposits and provide long service life.

PERFORMANCE FEATURES

SYSTEM EFFICIENCY

- Shell Refrigeration Oil S2 FR-A has been specially optimised for use in systems where oil separation is required. It has been designed to reduce 'light end' oil carryover; this helps minimise oil thickening in the compressor and reduces oil coating of internal evaporator surfaces thus maintaining overall system efficiency.

EXTENDED MAINTENANCE INTERVALS

- Shell Refrigeration Oil S2 FR-A has excellent high temperature and oxidation stability providing long service life even where high compressor discharge temperatures are found.
- In addition it is formulated to provide excellent control of deposit and sludge formation, contributing to extended oil drain intervals, in comparison with conventional mineral oil based refrigerator oils.

APPLICATIONS

REFRIGERATOR COMPRESSORS

- Shell Refrigeration Oil S2 FR-A is recommended for use in open, semi-open and hermetic compressors in domestic, commercial and industrial refrigeration systems. It can be used in both rotary and reciprocating compressor types.

REFRIGERANT COMPATIBILITY

- Shell Refrigeration Oil S2 FR-A is recommended for use with ammonia (R717) based refrigeration systems where it offers excellent performance, even under high compressor discharge temperatures, or down to evaporation temperatures of -30°C.
- It can also be used in systems using hydrocarbons such as propane (R290).
- Shell Refrigeration Oil S2 FR-A is not recommended for use with CFC, HCFC or HFC refrigerants such as R12, R22 or R134a.

SEAL COMPATIBILITY

- Shell Refrigeration Oil S2 FR-A is compatible with all commonly used sealing materials designed for use with mineral oils.

LUBRICANT COMPATIBILITY

- Shell Refrigeration Oil S2 FR-A is completely miscible with mineral oil, alkylated benzene and PAO based lubricants.

SPECIFICATIONS, APPROVALS AND RECOMMENDATIONS

MEETS THE REQUIREMENTS OF:

- DIN 51503 KAA and KE.

TYPICAL PHYSICAL CHARACTERISTICS

CHARACTERISTICS	
Kinematic Viscosity (ISO 3448) @ 40°C mm ² /s	68
@ 100°C mm ² /s	9
Refrigerator Oil (DIN 51503)	CAA, KE
Density @ 15°C kg/m ³ (ISO 12185)	862
Flash Point °C (COC) (ISO 2592)	232
Pour Point °C (ISO 3016)	-39
Miscibility with R290	Completely miscible with hydrocarbon based refrigerants

SHELL REFRIGERATION OIL S4 FR-F

SYNTHETIC REFRIGERATOR COMPRESSOR LUBRICANT

PREVIOUSLY SHELL CLAVUS R

DESIGNED TO MEET CHALLENGES

Shell Refrigeration Oil S4 FR-F is a synthetic lubricant with a polyolester base fluid. This lubricant has been developed for use with R134a and other environmentally acceptable HFC refrigerants.

PERFORMANCE FEATURES

EXTENDED MAINTENANCE INTERVALS

- Shell Refrigeration Oil S4 FR-F is a high-tech synthetic refrigerator oil based on polyolester fluids.
- Shell Refrigeration Oil S4 FR-F has excellent thermal and oxidation stability. This results in a high performance level of the oil over a long period of time.

WEAR PROTECTION

- Helps to minimise wear in bearings and pistons, the most critical parts of a reciprocating type compressor.

APPLICATIONS

REFRIGERATOR COMPRESSORS

- Shell Refrigeration Oil S4 FR-F is recommended for use in open, semi-open and hermetic compressors operating with refrigerants such as R134a, R23, R404A, R407C, R507 and other blends of HFC refrigerants.
- Shell Refrigeration Oil S4 FR-F is compatible with elastomers commonly used in refrigeration systems.

REFRIGERATOR PLANT DESIGN

- For applications of refrigeration and air-conditioning such as: industrial, refrigeration, refrigeration systems for food storage, mobile and stationary air-conditioning. When switching to new refrigerants and refrigerator oils the requirements of the refrigeration system manufacturer have to be followed.

PRODUCT HANDLING

- The hygroscopic nature of the base fluid has to be taken into consideration and it is recommended that, when filling the system, air contact should be avoided as much as possible. Once an oil pack has been opened it must be sealed carefully after use and the remaining contents should be used within a few days.

SPECIFICATIONS, APPROVALS AND RECOMMENDATIONS

MEETS THE REQUIREMENTS OF:

- DIN 51503 KD.

TYPICAL PHYSICAL CHARACTERISTICS

CHARACTERISTICS	68
Kinematic Viscosity (ISO 3104) @ 40°C mm ² /s	66
@ 100°C mm ² /s	8.8
Refrigerator Oil Group (DIN 51503)	KD
Density @ 15°C kg/m ³ (ISO 12185)	991
Flash Point °C (COC) (ISO 2592)	>230
Pour Point °C (ISO 3016)	-42
TAN (pH=11,0) mg KOH/g ASTM D664-97 mod.	<0.06
Floc-point with R134 °C (DIN 51351)	<-30
Miscibility with R134a 2% oil °C	-54/98
Miscibility with R134a 20% oil °C	-34/94
Miscibility with R12 °C	<60/>+100

SHELL REFRIGERATION OIL S4 FR-V

SYNTHETIC REFRIGERATOR COMPRESSOR LUBRICANT

PREVIOUSLY SHELL CLAVUS AB

DESIGNED TO MEET CHALLENGES

Shell Refrigeration Oil S4 FR-V is a synthetic refrigeration lubricant based on alkylated benzenes. Compatible with all commonly used refrigerants with the exception of HFCs. They are particularly recommended for refrigerator compressors operating with ammonia and HCFC as refrigerant.

PERFORMANCE FEATURES

SYSTEM EFFICIENCY

- Shell Refrigeration Oil S4 FR-V has high solvency and is designed to maintain refrigerant cleanliness and efficiency.

EXTENDED MAINTENANCE INTERVALS

- Shell Refrigeration Oil S4 FR-V has excellent high temperature and oxidation stability providing long service life even where high compressor discharge temperatures are found.
- In addition it is formulated to provide excellent control of deposit and sludge formation, contributing to extended oil drain intervals, in comparison with mineral oil based refrigerator oils.

APPLICATIONS

REFRIGERATOR COMPRESSORS

- Shell Refrigeration Oil S4 FR-V is recommended for use in open, semi-open and hermetic compressors in domestic, commercial and industrial refrigeration systems. It can be used in both rotary and reciprocating compressor types.

REFRIGERANT COMPATIBILITY

- Shell Refrigeration Oil S4 FR-V is designed for use with most commonly occurring refrigerants:
- Ammonia (R717) systems where it offers excellent performance, even under high compressor discharge temperatures or down to evaporation temperatures of -33°C or lower.
- Carbon dioxide (R744) systems.
- CFC and HCFC systems (R12 and R22).
- Hydrocarbon systems such as propane (R290).

SEAL COMPATIBILITY

- Shell Refrigeration Oil S4 FR-V is compatible with all commonly used sealing materials used with mineral oils.

LUBRICANT COMPATIBILITY

- Shell Refrigeration Oil S2 FR-V is completely miscible with mineral oil, other alkylated benzene and PAO based lubricants.

SPECIFICATIONS, APPROVALS AND RECOMMENDATIONS

MEETS THE REQUIREMENTS OF:

- DIN 51503 KAA and KC.

TYPICAL PHYSICAL CHARACTERISTICS

CHARACTERISTICS	68
Kinematic Viscosity (ASTM D 445) @ 40°C mm ² /s	68
@ 100°C mm ² /s	6.2
Refrigerator Oil Group (DIN 51503)	CAA, KC
Density @ 15°C kg/m ³ (ISO 12185)	871
Flash Point °C (COC)	190
Pour Point °C	-39
Neutralisation number mg KOH/g (ASTM D 664) (TAN)	<0.04
Saponification number °C (DIN 51351)	0.08
Floc Point R12h (DIN 51593)	<-30
Stability with Refrigerants h (DIN 51593)	>96
Miscibility with Refrigerants	Completely miscible with hydrocarbon based refrigerants
Miscibility with R134a 2% oil C°	-54/98
Miscibility with R134a 20% oil C°	-34/94
Miscibility with R12 C°	<60/>+100

SHELL GADUS ESSENTIAL GUIDE TO GREASES

DESIGNED TO MEET CHALLENGES

KEY CHARACTERISTICS							APPLICATION						
SHELL GREASE	TIER (Higher is better)	THICKENER TYPE	BASE OIL VISCOSITY cSt @ 40°C	NLGI GRADE (Grease consistency)	TEMPERATURE RANGE	COLOUR	PLAIN BEARINGS	ROLLER BEARINGS	ENCLOSED GEARS	GEARED COUPLINGS	SLIDES, LINKAGES AND PINS	ELECTRIC MOTORS	WIRE ROPES
Shell Gadus S5 T460 1.5	S5	Polyurea	460	1.5	-40°C to 180°C	Brown	***	***	-	*	***	-	-
Shell Gadus S4 V2600AD 1.5	S4	Lithium calcium	2600	1.5	0°C to 130°C	Black	***	-	-	-	***	-	-
Shell Gadus S3 V460XD 2	S3	Lithium complex	460	2	-20°C to 150°C	Black	***	**	-	**	***	-	-
Shell Gadus S3 V460D 2	S3	Lithium complex	460	2	-20°C to 150°C	Black	***	**	-	**	***	-	-
Shell Gadus S3 V460 2	S3	Lithium complex	460	2	-20°C to 150°C	Brown	***	**	-	**	**	-	-
Shell Gadus S3 V220C 1	S3	Lithium complex	220	1	-25°C to 140°C	Red	**	***	-	*	*	*	-
Shell Gadus S3 V220C 2	S3	Lithium complex	220	2	-25°C to 140°C	Red	**	***	-	*	**	*	-
Shell Gadus S3 T220 2	S3	Polyurea	220	2	-20°C to 160°C	Brown	**	***	-	*	**	*	-
Shell Gadus S3 T100 2	S3	Polyurea	100	2	-20°C to 160°C	Brown	*	***	-	-	*	***	-
Shell Gadus S3 High Speed Coupling Grease	S3	Lithium	700	0.5	-30°C to 120°C	Brown	-	-	-	***	-	-	-
Shell Gadus S2 V1000AD 2	S2	Lithium calcium	1000	2	0°C to 130°C	Black	***	**	-	-	***	-	-
Shell Gadus S2 V220AC 2	S2	Lithium calcium	220	2	-20°C to 120°C	Red	**	***	-	*	**	*	-
Shell Gadus S2 V220AD 2	S2	Lithium calcium	220	2	-10°C to 120°C	Black	**	**	-	*	***	-	-
Shell Gadus S2 V220 00	S2	Lithium	220	00	-30°C to 110°C	Brown	*	*	***	**	**	-	*
Shell Gadus S2 V220 0	S2	Lithium	220	0	-20°C to 120°C	Brown	*	**	**	**	**	-	-
Shell Gadus S2 V220 1	S2	Lithium	220	1	-20°C to 120°C	Brown	*	***	*	**	**	-	-
Shell Gadus S2 V220 2	S2	Lithium	220	2	-20°C to 120°C	Brown	**	***	-	*	**	**	-
Shell Gadus S2 V100 2	S2	Lithium	100	2	-25°C to 130°C	Brown	*	***	-	-	*	***	-
Shell Gadus S2 V100 3	S2	Lithium	100	3	-20°C to 130°C	Brown	*	***	-	-	*	***	-
Shell Gadus S2 A320 2	S2	Calcium	320	2	-10°C to 60°C	Brown	**	-	-	-	*	-	**

PRODUCT-NAME SUFFIX KEY

- A = Wet (aqueous) conditions
- C = Coloured grease
- D = Contains solids, suitable for shock-load conditions
- H = Heavy duty
- K = Low temperatures
- L = Low load
- OG = Open gear
- P = Extreme/high pressure
- X = Extra/extreme performance

THICKENER GUIDE LETTERS

- T = Extreme-temperature performance using Shell polyurea thickeners
- U = Unusual non-melting thickeners or other applications
- V = Versatile, multipurpose applications using lithium and lithium complex thickeners

- *** Outstanding performance in application
- ** Good performance in application
- * Validate use with Shell representative
- Not suitable for this application
- n/a Not available in Tactic EMV

GREASE FEATURE													SHELL GREASE
OPEN GEARS	HIGH SPEED	LOW SPEED	HIGH TEMP.	LOW TEMP.	EXTREME PRESSURE	VIBRATION	WATER	SHOCK LOAD	LIFE	CONTAINS SOLIDS	PUMP-ABILITY	TACTIC EMV*	
-	*	***	***	***	***	***	***	**	***	-	*	n/a	Shell Gadus 55 T460 1.5
**	-	***	**	-	***	***	***	***	**	***	*	n/a	Shell Gadus 54 V2600AD 1.5
-	*	***	***	**	***	***	**	***	**	***	*	n/a	Shell Gadus 53 V460XD 2
-	*	***	***	**	***	***	**	***	**	***	*	***	Shell Gadus 53 V460D 2
-	*	***	***	**	***	***	**	**	**	-	*	n/a	Shell Gadus 53 V460 2
-	**	**	***	**	**	**	**	*	**	-	**	n/a	Shell Gadus 53 V220C 1
-	**	**	***	**	**	**	**	**	**	-	*	***	Shell Gadus 53 V220C 2
-	**	**	***	**	**	**	***	**	***	-	*	***	Shell Gadus 53 T220 2
-	***	*	***	**	*	**	***	*	***	-	**	n/a	Shell Gadus 53 T100 2
-	***	*	**	***	***	***	**	-	**	-	-	n/a	Shell Gadus 53 High Speed Coupling Grease
*	-	***	**	-	***	***	***	***	**	***	*	n/a	Shell Gadus 52 V1000AD 2
-	**	**	**	**	**	**	***	**	**	-	*	n/a	Shell Gadus 52 V220AC 2
*	*	**	**	*	***	***	***	***	**	***	*	n/a	Shell Gadus 52 V220AD 2
-	*	*	**	***	**	-	*	*	*	-	***	n/a	Shell Gadus 52 V220 00
-	*	*	**	**	**	-	*	*	*	-	***	n/a	Shell Gadus 52 V220 0
-	**	*	**	**	**	*	*	*	*	-	**	n/a	Shell Gadus 52 V220 1
-	**	**	**	**	**	**	*	**	*	-	*	n/a	Shell Gadus 52 V220 2
-	***	*	**	**	-	*	*	-	*	-	*	n/a	Shell Gadus 52 V100 2
-	***	*	**	**	-	*	*	-	*	-	-	n/a	Shell Gadus 52 V100 3
*	-	**	-	-	**	**	***	**	*	-	*	n/a	Shell Gadus 52 A320 2

* Available in Shell Tactic EMV automatic lubricators, designed to provide continuous lubrication, well-suited for difficult to access areas such as remote and hazardous locations.

SHELL GADUS KILN SEAL GREASE

SPECIAL KILN SEALANT GREASE

PREVIOUSLY KILN SEAL TI

DESIGNED TO MEET CHALLENGES

Shell Gadus Kiln Seal Grease is a premium grade lithium complex based sealant formulated specifically for the mineral sands industry.

It is formulated to withstand the high temperatures experienced in the rotary kiln's mechanical seals yet provide an effective seal under heavy loads.

PERFORMANCE FEATURES

Shell Gadus Kiln Seal Grease contains anti-rust and antioxidant additives to control corrosion and suppress premature oxidation of the sealant.

- The tackiness additives in Shell Gadus Kiln Seal Grease assist in adhesion of the product to seal faces.
- Shell Gadus Kiln Seal Grease has good mechanical stability.
- Shell Gadus Kiln Seal Grease has excellent sealing characteristics under heavy loads and low rotary speed conditions.

SHELL GADUS KILN SEAL GREASE EXHIBITS SUPERIOR PERFORMANCE IN TERMS OF:

- Lower consumption rate than basic lithium greases.
- Excellent pumpability in normal Australian conditions which makes it ideal for automatic centralised pumping equipment even over long distances.
- Compared to basic lithium greases Shell Gadus Kiln Seal Grease offers a reduction in sealant wastage and hence potentially reduced disposal problems and associated cost.

TYPICAL PHYSICAL CHARACTERISTICS

CHARACTERISTICS	
Appearance	Brown
Worked Penetration @ 25°C 0.1mm (ASTM D 217)	340
Dropping Point °C (IP 396)	240
Oil Separation 18h @ 40°C %m (IP 121)	4.0
Viscosity of Base Oil @ 100°C mm ² /s (ASTM D 445)	14.5
EMCOR Corrosion Test (IP 220)	0/0

SHELL GADUS S2 A320

HIGH PERFORMANCE MULTI-PURPOSE EXTREME PRESSURE GREASE

PREVIOUSLY SHELL RHODINA EP (LF)

DESIGNED TO MEET CHALLENGES

Shell Gadus S2 A320 is a smooth textured, calcium based grease for undemanding industrial and marine applications at moderate temperatures requiring extreme pressure performance.

PERFORMANCE FEATURES

GOOD WATER RESISTANCE

- Withstands washing with water, helping to prevent loss of protection.

EXTREME PRESSURE PERFORMANCE

- Protects components from excessive wear under heavy loads.

APPLICATIONS

- Plain bearings working under arduous conditions in the presence of water.
- Shell Gadus S2 A320 is not recommended for rolling element bearings.
- Stern Tube Bearings, Cranes, Davits, Winches, Windlass.
- Low or Medium duty open gearing.
- Wire ropes in general use.

ADDITIONAL INFORMATION

- Operating temperature range -10°C to $+60^{\circ}\text{C}$.
- Peak temperatures up to 80°C (short periods).

SEALS

- Shell Gadus S2 A320 is compatible with normal mineral oil seal materials.

TYPICAL PHYSICAL CHARACTERISTICS

CHARACTERISTICS	2
Colour	Brown
Soap Type	Calcium
Base Oil Type	Mineral Oil
Kinematic Viscosity (IP 71/ASTM D 445) @ 40°C mm^2/s	320
@ 100°C mm^2/s	27
Dropping Point $^{\circ}\text{C}$ (IP 132/ASTM D 566-76)	85
Cone Penetration worked @ 25°C 0.1mm (IP 50/ASTM D 217)	265-295
Pumpability (long distance)	Fair

SHELL GADUS S2 THREAD COMPOUND

STORAGE AND THREAD COMPOUNDS FOR USE IN THE OIL INDUSTRY

RECOMMENDED REPLACEMENT FOR SHELL MALLEUS GREASE STC

DESIGNED TO MEET CHALLENGES

Shell Gadus S2 Thread Compound are storage and thread compounds, meeting the requirements of the DEA 47(E) Committee for use as 'green' dopes. These greases are based on highly refined mineral oils with a calcium soap thickener and suitable additives to provide excellent corrosion protection, helping to prevent galling of threads and ensure consistent make/break torques.

PERFORMANCE FEATURES

- Shell Gadus S2 Thread Compound contains no metals (Pb, Zn, Cu) in metallic form or other components identified by the Paris Commission (PARCOM) (e.g. PTFE, nylon or other polymers).

PROVEN PERFORMANCE IN FIELD TESTS

- Successfully applied in suitable applications.

EXCELLENT ANTI-CORROSION PERFORMANCE ALSO PROVIDED

- Shell Gadus S2 Thread Compound can be used as an effective corrosion preventive, allowing mills to only use one product and simplifying operations for production and drilling companies who do NOT have to remove protectives before applying a thread compound.

EXCELLENT BRUSHABILITY

- Can be applied even at low temperatures.

EXCELLENT ANTI-GALLING PERFORMANCE

- For carbon steels and up to 13% chromium steels Shell Gadus S2 Thread Compound helps minimise damage to pipe threads from galling.

EXCELLENT WATER WASH-OUT RESISTANCE

- Maintains protection and helps prevent corrosion.
- Essential qualities for vehicles working in wet environments.

APPLICATIONS

- Thread compounds for use with Rotary shouldered connectors.

ADDITIONAL INFORMATION

- Operating temperature range -20°C to 60°C.

TYPICAL PHYSICAL CHARACTERISTICS

CHARACTERISTICS	2
Colour	Black
Soap Type	Calcium
Base Oil Type	Mineral
Kinematic Viscosity (IP 71/ASTM D 445) @ 40°C mm ² /s	120
@ 100°C mm ² /s	12.0
Cone Penetration worked @ 25°C 0.1mm (IP 50/ASTM D 217)	265–295
Dropping Point °C	140
Applicability at low temperatures	Excellent

SHELL GADUS S2 V100

HIGH PERFORMANCE MULTI-PURPOSE GREASE

PREVIOUSLY SHELL ALVANIA RL

DESIGNED TO MEET CHALLENGES

Shell Gadus S2 V100 are general purpose industrial greases based on a new lithium hydroxystearate soap thickener fortified with anti-oxidant, anti-wear and anti-rust additives.

PERFORMANCE FEATURES

RELIABLE HIGH TEMPERATURE PERFORMANCE

- Very good performance up to +130°C.

GOOD OXIDATION AND MECHANICAL STABILITY

- Helps to resist the formation of deposits caused by oxidation at high operating temperatures. Shell Gadus S2 V100 are extremely stable under vibrations.

GOOD CORROSION RESISTANCE CHARACTERISTICS

- Effective protection in hostile environments.

LONG STORAGE LIFE

- Does not alter in consistency during prolonged storage.

APPLICATIONS

- Rolling element and plain grease lubricated bearings.
- Electric motor bearings.
- Sealed-for-life bearings.
- Water pump bearings.
- Shell Gadus S2 V100 may be used under a wide range of operating conditions. They offer very significant advantages over conventional lithium greases at high temperature or in the presence of water.

SHELL GADUS S2 V100 2

- A medium consistency grease designed, mainly, for general industrial lubrication. Ideal for centralised lubrication systems operating at normal temperatures.

SHELL GADUS S2 V100 3

- A medium/hard high performance industrial grease, particularly recommended for the lubrication of electrical motor bearings.

TYPICAL PHYSICAL CHARACTERISTICS

CHARACTERISTICS	2	3
Soap Type	Lithium hydroxystearate	
Base Oil Type	Mineral	Mineral
Kinematic Viscosity (IP 71/ASTM D 445) @ 40°C mm ² /s @ 100°C mm ² /s	100.0 11	100.0 11
Cone Penetration worked @ 25°C 0.1mm (IP 50/ASTM D 217)	265–295	220–250
Dropping Point °C (IP 396)	180	180

SHELL GADUS S2 V1000AD

HIGH PERFORMANCE MULTI-PURPOSE HEAVY-DUTY 1000 AD GREASE WITH SOLIDS

PREVIOUSLY SHELL ALVANIA SDX 2

DESIGNED TO MEET CHALLENGES

Shell Gadus S2 V1000AD is a super high performance grease for the lubrication of industrial bearings subjected to the most arduous conditions. It is based on heavy-duty semi-synthetic base oils and a mixed lithium/calcium soap thickener. It contains extreme-pressure, anti-wear, anti-corrosion and adhesion additives. The addition of molybdenum disulphide provides additional resistance to shock loading.

PERFORMANCE FEATURES

PROTECTS EQUIPMENT UNDER THE HEAVIEST LOADS

- Contains molybdenum disulphide and specially selected extreme pressure additives to provide lubrication under severe operating conditions such as shock loading, severe vibration and boundary lubrication conditions.

LONGER GREASE LIFE

- Excellent mechanical stability resisting breakdown and softening. Its efficient load carrying ability means that Shell Gadus S2 V1000AD typically performs longer than conventional lithium greases, allowing extended intervals between regreasing.

EXCELLENT WATER RESISTANCE

- Resists water washout ensuring lasting protection against corrosion and ingress of contamination.

SUPERIOR ADHESION

- Forms a tenacious film resisting leakage and flingoff to protect under the most arduous conditions.

APPLICATIONS

- Shell Gadus S2 V1000AD is recommended for the lubrication of severe duty applications even in damp and hostile conditions including:
 - Heavy earth-moving pins and bushes.
 - Turntables.
 - Slow moving industrial journal and rolling element bearings.
- This grease is particularly suited where flingoff, water and vibration are problems and heavy shock loads are experienced. This grease is not recommended for high speed bearings.

OPERATING TEMPERATURE RANGE

- 0°C to 130°C.

TYPICAL PHYSICAL CHARACTERISTICS

CHARACTERISTICS	2
Colour	Black
Soap Type	Lithium/ Calcium
Base Oil Type	Semi-Synthetic
Kinematic Viscosity (ASTM D 445) @ 40°C mm ² /s @ 100°C mm ² /s	1000 60
Dropping Point °C (IP 396)	184
Cone Penetration worked @ 25°C 0.1mm (IP 50/ASTM D 217)	265–295
Timken OK Load N (ASTM D 2509)	34
4 Ball weld load Kg (ASTM D 2596)	500
Water Washout %m (ASTM D 1264)	<3

SHELL GADUS S2 V220

HIGH PERFORMANCE MULTI-PURPOSE EXTREME PRESSURE GREASE

RECOMMENDED REPLACEMENT FOR SHELL ALVANIA EP (LF)
AND SHELL RETINAX CS, CP



DESIGNED TO MEET CHALLENGES

Shell Gadus S2 V220 greases are high quality multi-purpose, extreme-pressure greases based on a blend of high viscosity index mineral oils and a lithium hydroxystreate soap thickener and contain extreme-pressure and other proven additives to help enhance their performance in a wide range of applications.

Shell Gadus S2 V220 greases are designed for multi-purpose grease lubrication of rolling element and plain bearings as well as hinges and sliding surfaces such as those found throughout most industrial and transport sectors.

PERFORMANCE FEATURES

OUTSTANDING LOAD CARRYING CAPACITY

- Shell Gadus S2 V220 greases contain special extreme-pressure additives which enable them to withstand heavy and shock loads without failure of the lubricant film.

IMPROVED MECHANICAL STABILITY

- This is particularly important in vibrating environments where poor mechanical stability can lead to grease softening with subsequent loss of lubrication performance and leakage.

GOOD RESISTANCE TO WATER WASH-OUT

- Shell Gadus S2 V220 greases have been formulated to offer resistance to water wash-out.

OXIDATION STABILITY

- Specially selected base oil components have excellent oxidation resistance. Their consistency will not alter in storage and they withstand high operating temperatures without hardening or forming bearing deposits.

ANTI-CORROSION PROTECTION

- Shell Gadus S2 V220 greases have an affinity with metal and have the ability to protect bearing surfaces against corrosion, even when the grease is contaminated with water.

APPLICATIONS

SHELL GADUS S2 V220 IS DESIGNED FOR:

- Heavy-duty bearings and general industrial lubrication.
- Heavy-duty plain and rolling element bearings operating under harsh conditions including shock loading in wet environments.
- Operation over the temperature range -20°C to 100°C for bearings operating at 75% of the maximum rated speed (can withstand up to 120°C intermittently).

SHELL GADUS S2 V220 GREASE 1 IS DESIGNED FOR:

- Heavy-duty bearings served by centralised dispensing equipment.
- Extreme-pressure gear grease for applications at normal ambient temperature.
- Heavy-duty plain and rolling element bearings operating under harsh conditions including shock loading in wet environments.
- Low temperature greasing applications.

SHELL GADUS S2 V220 GREASES 00 AND 0 ARE SPECIFICALLY DESIGNED FOR:

- Steel mill lubrication where a softer grease is necessary for specialised dispensing systems.
- Heavy-duty plain and rolling element bearings operating under harsh conditions including shock loading in wet environments.

RE-GREASING INTERVALS

- For bearings operating near their maximum recommended temperatures, re-greasing intervals should be reviewed.

NOTE: Care should be taken to ensure that the grease does NOT come into contact with hydraulic brake rubber components.

SPECIFICATIONS, APPROVALS AND RECOMMENDATIONS

MEETS THE FOLLOWING SPECIFICATIONS:

- British Timken specification for Steel Mill applications.

TYPICAL PHYSICAL CHARACTERISTICS

CHARACTERISTICS	00	0	1	2
Soap Type	Lithium	Lithium	Lithium	Lithium
Base Oil	Mineral	Mineral	Mineral	Mineral
Kinematic Viscosity (IP 71/ASTM D 445)				
@ 40°C mm ² /s	220	220	220	220
@ 100°C mm ² /s	19	19	19	19
Dropping Point $^{\circ}\text{C}$ (IP 396)	–	–	180	180
Cone Penetration worked at 25°C 0.1mm (IP 50/ASTM D 217)	400–430	355–385	310–340	265–295

SHELL GADUS S2 V220AC

HIGH PERFORMANCE MULTI-PURPOSE EXTREME-PRESSURE GREASE

RECOMMENDED REPLACEMENT FOR SHELL ALVANIA HD 2 AND SHELL RETINAX HD2

DESIGNED TO MEET CHALLENGES

Shell Gadus S2 V220AC grease is a high quality multi-purpose grease based on high viscosity index mineral oil and a mixed lithium/calcium soap thickener. It contains extreme-pressure, anti-wear, anti-oxidation and anti-corrosion additives to enhance its performance in a wide range of applications.

PERFORMANCE FEATURES

EXCELLENT MECHANICAL STABILITY EVEN UNDER VIBRATING CONDITIONS

- Consistency retained over long periods, even in conditions of severe vibration.

GOOD CORROSION RESISTANCE

- Helps to provide protection from the elements of corrosion.

EXTENDED LIFE AT MODERATE TEMPERATURES

- Allows longer periods between maintenance schedules reducing down-time and grease consumption. Demonstrated to work in the field with regreasing intervals above 30,000 kms even for demanding applications such as transmission joints.

GOOD OIL SEPARATION

- Ensures effective lubrication and reliable performance.

APPLICATIONS

- Heavy-duty plain and rolling element bearings operating in the following environments:
 - Vibrating conditions
 - Heavy load
 - High temperature
 - Shock load
 - Presence of water.

Multi-purpose convenience, especially in the transport sector where product can be used for both wheel bearings and chassis lubrication of passenger cars, light trucks and heavy-duty trucks. This grease is also suitable for construction equipment exposed to intense water washout.

OPERATING TEMPERATURE RANGE

Shell Gadus S2 V220AC grease are recommended for the grease lubrication of heavy-duty bearings operating up to their maximum rated speed over the temperature range -20°C to 130°C (140°C peak).

SPECIFICATIONS, APPROVALS AND RECOMMENDATIONS

MEETS THE FOLLOWING SPECIFICATIONS:

- ASTM D4950-08 LB.

TYPICAL PHYSICAL CHARACTERISTICS

CHARACTERISTICS	2
Colour	Red
Soap Type	Lithium/ Calcium
Base Oil Type	Mineral
Kinematic Viscosity (IP 71/ASTM D 445) @ 40°C mm ² /s	220
@ 100°C mm ² /s	18
Dropping Point °C (IP 396)	175
Cone Penetration worked @ 25°C 0.1mm (IP 50/ASTM D 217)	265-295

SHELL GADUS S2 V220AD

HIGH PERFORMANCE HEAVY-DUTY GREASE CONTAINING SOLID LUBRICANTS

RECOMMENDED REPLACEMENT FOR SHELL ALVANIA HDX AND SHELL RETINAX HDX 2

DESIGNED TO MEET CHALLENGES

Shell Gadus S2 V220AD is a very high performance grease for the lubrication of industrial bearings subjected to the most arduous conditions. It is based on high viscosity index mineral oil and a mixed lithium/calcium soap thickener and contains extreme-pressure, anti-oxidation, anti-wear, anti-corrosion and adhesion additives. It also contains molybdenum disulphide to provide resistance to shock loading.

PERFORMANCE FEATURES

GOOD OXIDATION AND MECHANICAL STABILITY

- Formulated to resist the formation of deposits caused by oxidation at high operating temperatures and maintains consistency, helping to reduce leakage.

GOOD CORROSION RESISTANCE

- Provides protection from the elements of corrosion.

FOR SHOCK LOADED CONDITIONS

- Helps to resist breakdown, softening and subsequent leakage under shock loads.

GOOD ADHESION PROPERTIES

- Helps to reduce losses and grease consumption.

EXTREME PRESSURE PERFORMANCE

- Rig tests confirm EP additives in Shell Gadus S2 V220AD help prolong bearing life when subjected to heavy and shock loads.

APPLICATIONS

- Shell Gadus S2 V220AD is recommended for the lubrication of shock loaded heavy-duty bearings working in damp hostile conditions.

TYPICAL PHYSICAL CHARACTERISTICS

CHARACTERISTICS	1	2
Colour	Black	Black
Soap Type	Lithium/ Calcium	Lithium/ Calcium
Base Oil Type	Mineral	Mineral
Kinematic Viscosity (IP 71/ASTM D 445) @ 40°C mm ² /s	220	220
@ 100°C mm ² /s	18	18
Dropping Point °C (IP 396)	170	175
Cone Penetration worked at 25°C 0.1mm (IP 50/ASTM D 217)	310–340	265–295
4 Ball Weld Load Kg (IP 239)	315	315
Operating Temperature Range	-10°C–120°C	-10°C–120°C

SHELL GADUS S3 HIGH SPEED COUPLING GREASE

PREMIUM GEAR COUPLING GREASE

PREVIOUSLY SHELL ALBIDA GC 1

DESIGNED TO MEET CHALLENGES

Shell Gadus S3 High Speed Coupling Grease is a special grease for flexible gear coupling. Shell Gadus S3 High Speed Coupling Grease is a lithium polyethylene complex grease based on mineral oil, containing anti-oxidants, rust inhibitors, extreme pressure and anti-wear additives.

PERFORMANCE FEATURES

HIGH SPEED-RESISTS SEPARATION

- The grease has a unique design that resists separation during extreme centrifugal accelerations. While conventional products separate rapidly in centrifugal high speed gear couplings resulting in severe oil leakage, the structure and composition of Shell Gadus S3 High Speed Coupling Grease remains intact at accelerations up to 36,000 G.

EXTRA PROTECTION

- Helps to reduce components failure due to corrosion.
- Excellent load-carrying performance and reduced wear rates.

APPLICATIONS

- Shell Gadus S3 High Speed Coupling Grease was especially designed for lubrication of flexible gear couplings operating at speeds from 300rpm and up.

ADDITIONAL INFORMATION

- Operating temperature range -10°C to 120°C.

TYPICAL PHYSICAL CHARACTERISTICS

CHARACTERISTICS	1
Colour	Dark Brown
Soap Type	Lithium / Complex
Soap Content °C	<3%
Base Oil Type	Mineral
Kinematic Viscosity (IP 71/ASTM D 445) @ 40°C mm ² /s	700
@ 100°C mm ² /s	34
NLGI	1
Cone Penetration worked @ 25°C 0.1mm (IP 50/ASTM D 217)	310-340
Dropping Point °C (IP 396)	>150

SHELL GADUS S3 REPAIR

PREMIUM OPEN GEAR RUNNING IN GREASE CONTAINING SOLIDS

PREVIOUSLY SHELL MALLEUS RN

DESIGNED TO MEET CHALLENGES

Shell Gadus S3 Repair is a high performance sprayable running in aluminium complex grease, based on a part synthetic base oil blend and contains micronised graphite as solid lubricant. The product chemistry is designed to cause a well-controlled smoothing process to reduce surfaces roughness on new and damaged open gearing.

PERFORMANCE FEATURES

Shell Gadus S3 Repair not only designed to reduce surface roughness of first time operating open gears but also improves used tooth flanks surface with a 'cleaning' and corrective effect.

The product can also be used in case of light tooth damage smoothing surface roughness on the load carrying tooth flanks and increasing the contact area.

SUPERIOR RUNNING IN PERFORMANCE

- Shell Gadus S3 Repair advanced formulation is designed to ensure a well-controlled smoothing process through chemical reaction in the zones being under higher load. This controlled wear process is designed to allow the gearing to obtain the maximum load distribution between the girth and pinion gearing.

PERIODIC SMOOTH LAPPING OF TOOTH PROFILE

- It is considered to be a good maintenance practice to apply a 180 kg drum of Shell Gadus S3 Repair once per year, or every 6,000 hours of operation, to remove fatigue micro-cracks or micro-pitting (not really visible to the naked eye) well before they increase in size, causing long-term future irreversible damage.

ENDORSED BY LEADING OPEN GEAR MANUFACTURERS

- Ferry Captain, one of the major open gear manufacturers, endorses Shell Gadus S3 Repair.

ENVIRONMENTAL ADVICES

- Shell Gadus S3 Repair is bitumen and solvent free.

APPLICATIONS

For mining, cement, steel industries and power stations, open gears on:

- Grinding mills
- Rotary kilns and dryers.

Shell Gadus S3 Repair is a ready-to-use product, which can be applied through conventional automatic lubrication spraying systems or manual pressurised-air hand spraying equipment.

It is important to consult the appropriate consumption charts to determine the specified quantities of lubricant to apply. Incorrect consumption quantities could result in tooth damage.

OPERATING TEMPERATURE RANGE

- Automatic spraying system from -15°C to 100°C.
- Lubrication film from -30°C up to 200°C.

TYPICAL PHYSICAL CHARACTERISTICS

CHARACTERISTICS	00
Colour	Black
Soap Type	Al Complex
Texture (visual)	Tacky
Base Oil Type	Part-Synthetic
Solid Lubricant	–
Density at 15.5°C kg/m ³ (Gardener method)	1.0
Kinematic Viscosity (ISO 3104)	
@ 40°C mm ² /s	520
@ 100°C mm ² /s	32
Base Oil Viscosity (IP 71/ASTM D 445)	
@ 40°C mm ² /s	–
@ 100°C mm ² /s	–
Dropping Point °C (IP 396/ASTM D 566-76)	240
Cone Penetration worked @ 25°C 0.1mm (ASTM D 217)	400–430
4 Ball Weld Load N	8000
4 Ball Test Kg (ASTM D 596)	–
4 Ball Wear Scar mm (ASTM D 2266)	–
4 Ball Load Wear Index (ASTM D 2596)	–
FZG A/2.76/50 (DIN 51354) Load Stage pass	–
Rust Test (ASTM D 1743)	Pass
Copper Strip Corrosion 3h @ 100°C	18

CONSUMPTION QUANTITY GUIDELINES

APPLICATION TYPE	DOUBLE-PINION MILL DRIVE (TYPE 4)	SMALL ROTARY DRUM (TYPE 2)
1. Small rotary drums (e.g. dryer units) <750kw	4	–
2. Small single-pinion kiln drives <750kw	5	–
3. Average single-pinion drives of mills and kilns >751–<2500kw	6	–
4. Large single-pinion mill drives and double-pinion kiln drives >250kw	7	–
5. Double-pinion mill drives	8	–
The above recommended consumption quantities only apply to Shell Gadus S3 Repair. kw = Kilowatt power rating of the electrical motor, driving the gear train		
Required specific consumption quantity [cc/[cm x op. hour]]	– 7	5
Flank width (cm)	– 85	40
Consumption quantity/op. hour (cc) cc to kg/by 1000	– 7 x 85 = 595cc	5 x 40 = 200cc
Consumption quantity/24 op. hours (kg)	– 0.59cc x 24op = 14.28kg per day	0.20cc x 24op = 4.8kg per day

In the case of double-pinion drives with pinion lubrication the consumption quantity should be doubled and distributed evenly to both spray bars.
cc = cubic centimeters cm = centimeters of the tooth flank width
op = operating hours per day kg = Kilograms

SHELL GADUS S3 OG 2

SPECIAL PURPOSE OPEN GEAR AND WIRE ROPE GREASE

RECOMMENDED REPLACEMENT FOR SHELL MALLEUS GREASE OGM EXTRA HEAVY

DESIGNED TO MEET CHALLENGES

Shell Gadus S3 OG 2 is primarily designed for applications in mining equipment, shovels and excavators in open cut operations.

Shell Gadus S3 OG 2 is based on Aluminium Complex soap thickener dispensed in a high viscosity base oil containing enhanced extreme pressure-antiwear chemistry.

PERFORMANCE FEATURES

LOAD CARRYING CAPACITY UNDER SEVERE OPERATION CONDITIONS

- Shell Gadus S3 OG 2 contains selected components to help ensure excellent resistance to shock and permanent heavy load.

VERY HIGH MECHANICAL AND THERMAL STABILITY

- Shell Gadus S3 OG 2 thickener structure is designed to resist mechanical stress and high temperature.

WITHSTANDING SEVERE OPERATION CONDITIONS

- Like dust and dirt contamination, water, changes in temperature.

MAINTAIN OVER TIME ADHESIVE CHARACTERISTICS

- Formulated with performing and advanced polymer technology to help ensure durable protection.

APPLICATIONS

Typical applications for Shell Gadus S3 OG 2 are:

- Open gears
- Sticks
- Circle Rail and rollers
- Antifriction bearings
- Bushings.

OPERATING TEMPERATURE RANGE

- 0°C to 60°C

SPECIFICATIONS, APPROVALS AND RECOMMENDATIONS

MEETS THE REQUIREMENTS OF:

- Liebherr Specification.

TYPICAL PHYSICAL CHARACTERISTICS

CHARACTERISTICS	2
NLGI Consistency	2
Colour	Black
Soap Type	Aluminium Complex
Base Oil Type	Mineral
Solid Lubricant	Yes
Base Oil Viscosity (IP 71/ASTM D 445) @ 40°C mm ² /s	3200
@ 100°C mm ² /s	110
Cone Penetration worked @ 25°C 0.1mm (IP 50/ASTM D 217)	275–295
Dropping Point °C (IP 132/ASTM D 566-76)	240
4 Ball Test Kg (IP 236)	620
4 Ball Wear Scar mm (ASTM D 2266)	max. 0.7
4 Ball Load Wear Index (LWI) kg (ASTM D 2596)	120
Rust Test (ASTM D 1743)	Pass
Copper Strip (ASTM D 4048)	1b

SHELL GADUS S3 T100

PREMIUM QUALITY INDUSTRIAL BEARING GREASE

RECOMMENDED REPLACEMENT FOR SHELL STAMINA RL

DESIGNED TO MEET CHALLENGES

Shell Gadus S3 T100 is a high technology grease designed to give optimum performance for grease lubrication in industrial bearings. Shell Gadus S3 T100 is based on mineral oil with a special diurea thickener to give long life, low wear and shear-stable properties at high temperatures.

PERFORMANCE FEATURES

- Outstanding life at high temperatures
- Excellent wear protection
- Excellent mechanical stability at high temperatures
- Excellent oxidation resistance
- Good protection against false brinnelling
- Low oil separation
- Excellent corrosion resistance
- Provides protection from the elements of corrosion
- Versatile
- Water resistant
- Withstands washing with water, preventing loss of protection.

HIGH TEMPERATURE PERFORMANCE

- The diurea thickener used in Shell Gadus S3 T100 has a high melting point and the grease performance is limited only by the properties of the base oil and additive components.
- The low volatility and excellent oxidation stability of the base oil are such that they give it an excellent service life in bearings operating between -20°C and 150°C. With caution, Shell Gadus S3 T100 may, in some circumstances, be used at temperatures up to 180°C, but only if the re-lubrication period is suitably adjusted.

CORROSION PROTECTION

- When a bearing is running, most high quality greases can maintain an adequate lubricating film even when the grease is loaded with water. However, when the grease bearing is idle, corrosion may occur causing pitting which can be destructive. Shell Gadus S3 T100 is formulated with corrosion inhibitors to help protect bearing surfaces even when the grease is contaminated with water.
- The lubrication properties of Shell Gadus S3 T100 have been used very successfully in slow moving, loaded large bearings such as those found in continuous casters in steel plants.

APPLICATIONS

- Shell Gadus S3 T100 is particularly recommended for use in high temperature (150°C), lightly loaded industrial bearings.
- It is recommended for use where long operational life and extended re-greasing intervals are an important consideration.

OPERATING TEMPERATURE RANGE

- -20°C to 150°C.

RE-LUBRICATION

Grease life varies considerably from application to application, even with bearings operating under normally identical conditions. Variables such as air flow, dirt and humidity can have a considerable effect in addition to the more commonly recognised parameters of load, speed and temperature.

The use of Shell Gadus S3 T100 usually permits considerable extension of the re-lubrication interval.

OXIDATION STABILITY

Shell Gadus S3 T100 has a high temperature oxidation inhibitor system to help ensure that it will withstand high operating temperatures without forming deposits. Unlike the soap thickeners used in most greases, the diurea thickener in Shell Gadus S3 T100 does not catalyse grease oxidation, indeed the diurea thickener offers inherent anti-oxidant properties. This contributes to longer grease life at higher temperatures.

The base oil component of Shell Gadus S3 T100 is a specially selected high viscosity index mineral oil with excellent oxidation and evaporation resistance.

SEALING

The rheology of Shell Gadus S3 T100 is such that at low shear rates and with heating the consistency increases. Consequently, in bearings operating at high temperatures the grease remains in place providing good sealing and continuous lubrication even in the presence of vibration.

WATER WASHOUT

Shell Gadus S3 T100 exhibits very good resistance to water washout by immersion or spray.

TYPICAL PHYSICAL CHARACTERISTICS

CHARACTERISTICS	2
Colour	Brown
Soap Type	Diurea
Base Oil Type	Mineral
Base Oil Viscosity (IP 71/ASTM D 445) @ 40°C mm ² /s	100
@ 100°C mm ² /s	11
Dropping Point °C (IP 132/ASTM D 566-76)	250
Cone Penetration worked @ 25°C 0.1mm (IP 50/ASTM D 217)	265-295
Pumpability (long distance)	Fair

SHELL GADUS S3 T220

ULTIMATE PERFORMANCE EXTREME PRESSURE DIUREA GREASE

PREVIOUSLY SHELL STAMINA EP

DESIGNED TO MEET CHALLENGES

Shell Gadus S3 T220 Greases are high technology greases designed to give optimum performance for grease lubrication in industrial bearings. They are based on mineral oil with a special diurea thickener to give long life, low wear and shear-stable properties at high temperatures.

PERFORMANCE FEATURES

POTENTIAL COST SAVINGS VIA:

- Formulated to reduce grease consumption at high temperatures, as grease resists melting and subsequent leakage, due to the use of the latest diurea thickener technology developed by Shell's 'in house' expertise in Japan.
- Helps to reduce maintenance costs since lower bearing replacement rates can be achieved, due to the excellent anti-wear properties that are available from the latest technology diurea thickened greases.
- Helps to lower total labour costs, due to the extended lubrication intervals and less downtime that results from using the latest in high performance greases.
- Simplified maintenance programs can be established, resulting from the multi-purpose capabilities of this grease and long service lives that are possible.

APPLICATIONS

- Steel
- Paper
- Aluminium
- Chemical
- and many others.
- Recommended as an extreme pressure grease for highly loaded ball, roller and plain bearing applications at high temperatures where extended service life is required. Proven in the following applications:
 - Hot strip mills
 - Paper mill bearings (dry end)
 - Electrical motors (large).

SPECIFICATIONS, APPROVALS AND RECOMMENDATIONS

IS RECOMMENDED FOR USE:

- Over the temperature range -10°C to 160°C (even up to 180°C with suitable adjustment of relubrication interval).

TYPICAL PHYSICAL CHARACTERISTICS

CHARACTERISTICS	2
Colour	Light Brown
Soap Type	Diurea
Base Oil Type	Mineral
Kinematic Viscosity (IP 71/ASTM D 445) @ 40°C mm ² /s @ 100°C mm ² /s	220 19
Dropping Point °C (IP 396)	260
Cone Penetration worked @ 25°C 0.1mm (IP 50/ASTM D 217)	280
Pumpability (long distance)	Fair

SHELL GADUS S3 V220C

PREMIUM MULTI-PURPOSE EXTREME PRESSURE GREASE

RECOMMENDED REPLACEMENT FOR SHELL ALBIDA EP AND SHELL RETINAX LX



DESIGNED TO MEET CHALLENGES

Shell Gadus S3 V220C Greases are premium multi-purpose greases based on high viscosity index mineral oil and a lithium complex thickener. They contain the latest additives to offer excellent high temperature oxidation performance and other additives to enhance their anti-oxidation, anti-wear and anti-corrosion properties.

Shell Gadus S3 V220C Greases are especially suitable for bearings operating at high temperature and under load.

PERFORMANCE FEATURES

EXCELLENT MECHANICAL STABILITY EVEN UNDER VIBRATING CONDITIONS

- Consistency retained over long periods, even in conditions of severe vibration.

ENHANCED EXTREME PRESSURE PROPERTIES

- Excellent load-carrying performance.

GOOD WATER RESISTANCE

- Ensures lasting protection even in the presence of large amounts of water.

HIGH DROPPING POINT LONG OPERATIONAL LIFE AT HIGH TEMPERATURES EFFECTIVE CORROSION PROTECTION

- Helps ensure components/bearings do not fail due to corrosion.

APPLICATIONS

Shell Gadus S3 V220C Greases are used for the grease lubrication of heavy-duty bearings used in machinery found in the following applications:

- Continuous casting
- Vibrating sieves
- Quarries
- Breakers
- Roller conveyors
- Automotive wheelbearings.

RE-GREASING INTERVALS

For bearings operating near their maximum recommended temperatures, re-greasing intervals should be reviewed.

SPECIFICATIONS, APPROVALS AND RECOMMENDATIONS

MEETS THE FOLLOWING SPECIFICATIONS

- Meets ASTM D 4950-68 C7C-L13.

TYPICAL PHYSICAL CHARACTERISTICS

CHARACTERISTICS	1	2
Colour	Red	Red
Soap Type	Lithium/Complex	Lithium/Complex
Base Oil Type	Mineral	Mineral
Kinematic Viscosity (IP 71/ASTM D 445) @ 40°C mm ² /s	220	220
@ 100°C mm ² /s	19	19
Dropping Point °C (IP 396)	240	240
Cone Penetration worked @ 25°C 0.1mm (IP 50/ASTM D 217)	310–340	265–295
Pumpability (long distance)	Good	Fair

SHELL GADUS S3 V460

PREMIUM MULTI-PURPOSE HEAVY-DUTY GREASE

RECOMMENDED REPLACEMENT FOR SHELL RETINAX SD AND SHELL ALBIDA HD

DESIGNED TO MEET CHALLENGES

Shell Gadus S3 V460 Grease is a premium, high temperature greases for heavy-duty industrial applications. This product is based on high viscosity index mineral oil and a lithium complex soap thickener and contains the latest additives to offer excellent high temperature oxidation performance and other additives to enhance its anti-oxidation, anti-wear and anti-corrosion properties.

Shell Gadus S3 V460 Grease is especially suitable for slow moving, heavy-duty bearings operating at high temperature and under severe load.

PERFORMANCE FEATURES

HIGH BASE OIL VISCOSITY TO MEET LEADING OEM REQUIREMENTS FOR SLOW MOVING LARGE BEARINGS

- Proven in workroll bending operations in steel plants.

EXCELLENT MECHANICAL STABILITY EVEN UNDER VIBRATING CONDITIONS

- Consistency retained over long periods, even in conditions of severe vibration.

ENHANCED EXTREME PRESSURE PROPERTIES

- Excellent load-carrying performance.

EXCELLENT WATER RESISTANCE

- Ensures lasting protection even in the presence of large amounts of water.

EFFECTIVE CORROSION PROTECTION

- Helps ensure components/bearings do not fail due to corrosion.

HIGH DROPPING POINT

- Resistant to high temperatures.

APPLICATIONS

Shell Gadus S3 V460 Grease are used for the grease lubrication of heavy-duty, slow moving bearings used in heavy industries:

- Steel (continuous casters, workroll bearings, etc.)
- Cement
- Paper
- Chemical industry
- Mining.

RE-GREASING INTERVALS

For bearings operating near their maximum recommended temperatures, re-greasing intervals should be reviewed.

TYPICAL PHYSICAL CHARACTERISTICS

CHARACTERISTICS	2
Colour	Light Brown
Soap Type	Lithium/ Complex
Base Oil Type	Mineral
Kinematic Viscosity (IP 71/ASTM D 445) @ 40°C mm ² /s @ 100°C mm ² /s	460 31
Dropping Point °C (IP 396)	250
Cone Penetration Worked @ 25°C 0.1mm (IP 50/ASTM D217)	265–295
Pumpability (Long distance)	Fair

SHELL GADUS S3 V460D

PREMIUM MULTI-PURPOSE HEAVY-DUTY GREASE WITH SOLIDS

RECOMMENDED REPLACEMENT FOR SHELL ALBIDA HDX

DESIGNED TO MEET CHALLENGES

Shell Gadus S3 V460D Grease is a high performance, high temperature grease for slow moving heavily loaded large bearings subject to shock loads. It is based on high viscosity index mineral oil and a lithium complex thickener. Apart from containing the latest additives to ensure excellent high temperature, anti-corrosion and anti-oxidation performance, it also contains Mos2 to ensure the grease can handle shock loads.

PERFORMANCE FEATURES

HIGH BASE OIL VISCOSITY TO PROVIDE EXCELLENT LOAD CARRYING PERFORMANCE

- Meets the recommended base oil viscosity recommended by leading OEMs.

EXCELLENT MECHANICAL STABILITY EVEN UNDER VIBRATING CONDITIONS

- Consistency retained over long periods, even in conditions of severe vibration.

ENHANCED EXTREME PRESSURE PROPERTIES AND RESISTANT TO SHOCK LOADS

- Excellent load-carrying performance enhanced by the presence of Mos2.

EXCELLENT WATER RESISTANCE

- Ensures lasting protection even in the presence of large amounts of water.

EFFECTIVE CORROSION PROTECTION

- Helps ensure components/bearings do not fail due to corrosion.

HIGH DROPPING POINT

- Resistant to high temperatures.

APPLICATIONS

Shell Gadus S3 V460D Grease is used for the grease lubrication of heavy-duty, slow moving bearings subject to shock loads found in the following industries:

- Mining
- Steel.

RE-GREASING INTERVALS

For bearings operating near their maximum recommended temperatures, re-greasing intervals should be reviewed.

SPECIFICATIONS, APPROVALS AND RECOMMENDATIONS

LISTED BY THE FOLLOWING OEMS:

- Komatsu Mining (Germany)
- Terex
- BE (certified)
- Dieffenbacher
- Hitachi
- Konecranes
- CMI
- Flat Products Equipments
- Pfeiffer
- Voith Paper Environmental.

MEETS THE REQUIREMENTS OF:

- The 3% Mos2 grease Caterpillar specification.

HAS APPROVAL FROM:

- Rothe Erde.

TYPICAL PHYSICAL CHARACTERISTICS

CHARACTERISTICS	2
Colour	Black
Soap Type	Lithium/Complex
Base Oil Type	Mineral
Kinematic Viscosity (IP 71/ASTM D 445) @ 40°C mm ² /s @ 100°C mm ² /s	460 31
Cone Penetration Worked @ 25°C 0.1mm (IP 50/ASTM D 217)	265–295
Dropping Point °C (IP 396)	>240

SHELL GADUS S3 V460XD

PREMIUM MULTI-PURPOSE HEAVY-DUTY GREASE WITH EXTRA SOLIDS

RECOMMENDED REPLACEMENT FOR SHELL ALBIDA MDX

DESIGNED TO MEET CHALLENGES

Shell Gadus S3 V460XD Grease is a premium heavy-duty grease designed for use in a wide range of industrial and mining applications. It is based on a high viscosity index mineral oil and lithium complex thickener. It contains selected additives to offer excellent high temperature oxidation performance and enhanced extreme pressure, anti-wear and anti-corrosion properties. It also contains molybdenum disulphide to provide additional resistance to shock loading.

PERFORMANCE FEATURES

WIDE OPERATING TEMPERATURE RANGE

- Ball and rolling element bearings operating continuously at temperatures between -15°C and 150°C.

PROLONGED GREASE SERVICE LIFE

- Enhanced oxidation resistance helps prolong grease life at higher temperatures, allowing extended re-greasing intervals.

EXCELLENT MECHANICAL STABILITY

- Maintains consistency over long periods even in the most severe conditions.

FOR SHOCK LOADED CONDITIONS

- Resists break down, softening and subsequent leakage under shock loads.

ENHANCE EXTREME PRESSURE AND ANTI-WEAR PROPERTIES

- Rig tests confirm E.P. additives in Shell Gadus S3 V460XD prolong the life of bearings subject to heavy loads and shock loads.

LOW WATER WASH-OUT

- Good water resistant properties.

EFFECTIVE CORROSION PROTECTION

- Helps ensure components/bearings do not fail due to corrosion.

APPLICATIONS

- Shell Gadus S3 V460XD Grease is used for the lubrication of shock loaded, heavy-duty slow moving bearings and non-bearing applications such as those found in large mobile mining equipment. Shell Gadus S3 V460XD Grease is available as NLGI 2 grease and also as an NLGI 1 version where a more pumpable grease is required.

SPECIFICATIONS, APPROVALS AND RECOMMENDATIONS

LISTED BY THE FOLLOWING OEMS:

- Komatsu
- Komatsu Trucks
- Terex
- Liebherr Trucks
- P&H
- BE (certified).

EXCEEDS THE SPECIFICATIONS OF:

- Caterpillar.

TYPICAL PHYSICAL CHARACTERISTICS

CHARACTERISTICS	2
Colour	Black
Soap Type	Lithium/ Complex
Base Oil Type	Mineral
Kinematic Viscosity (ASTM D 445) @ 40°C mm ² /s	460
@ 100°C mm ² /s	31
Dropping Point °C (IP 396)	250
4 Ball EP Test Kg (IP 239)	620
Molybdenum Disulphide Content %	5
Molybdenum Disulphide Particle Size (microns)	<5
Worked Penetration @ 25°C (ASTM D 17) (dmm)	265–295

SHELL GADUS S4 V2600AD

ADVANCED PLAIN BEARING GREASE (MALLEUS)

PREVIOUSLY SHELL MALLEUS JBZ

DESIGNED TO MEET CHALLENGES

Shell Gadus S4 V2600AD is a unique Lithium/Calcium thickened part-synthetic grease with superior adhesion and load carrying properties. It is formulated specially for very large and slow moving bearings, slides, bushes and other heavy-duty industrial applications.

PERFORMANCE FEATURES

PROTECTS EQUIPMENT UNDER THE HEAVIEST LOADS

- Contains molybdenum disulphide and specially selected extreme pressure additives to provide lubrication under severe operating conditions such as shock loading, severe vibration and boundary lubrication conditions.

LONGER GREASE LIFE

- Excellent mechanical stability resisting breakdown and softening. Its efficient load carrying ability means that Shell Gadus S4 V2600AD typically performs longer than conventional lithium greases, allowing extended intervals between re-greasing.

RESISTS GREASE LOSS AND CORROSION

- Excellent water and juice washout resistance helps to prevent grease loss and provide corrosion protection.

CLEANER WORKING ENVIRONMENT

- Contains no bitumen, solvents, highly aromatic base oils, lead or sodium nitrite, and this, together with reduced usage, minimal fling-off or leakage, provide a cleaner and safer working environment.

APPLICATIONS

Shell Gadus S4 V2600AD is recommended for the lubrication of:

- Sugar mill bearing
- Cement mill journals
- Plain bearings
- Pivot pins
- Slow speed cams and followers
- Open gears.

OPERATING TEMPERATURE RANGE

- 0°C to 130°C.

TYPICAL PHYSICAL CHARACTERISTICS

CHARACTERISTICS	1.5
Colour	Black
Soap Type	Lithium/ Calcium
Base Oil Type	Part-Synthetic
Kinematic Viscosity (IP 71/ASTM D 445) @ 40°C mm ² /s	2600
@ 100°C mm ² /s	120
NLGI Consistency	1.5
Cone Penetration worked @ 25°C 0.1mm (IP 50/ASTM D 217)	305
Dropping Point °C (IP 396)	180
Timken OK Load °C (ASTM D 2509)	38.6
4 Ball Weld kg (IP 239)	820
Copper Corrosion (ASTM D 130)	1b
Emcor Corrosion in Distilled Water (IP 220)	0.0

SHELL GADUS S4 V460D

ADVANCED MULTI-PURPOSE HEAVY-DUTY GREASE

PREVIOUSLY SHELL ALBIDA GREASE HDZX

DESIGNED TO MEET CHALLENGES

Shell Gadus S4 V460D Grease is a high performance high temperature grease for slow moving heavily loaded pins, bushes and large bearings subject to shock loads. They are based on PAO synthetic oil and high viscosity index mineral oil and a lithium complex thickener. Apart from containing the latest additives to ensure excellent high temperature, anti-corrosion and anti-oxidation performance, they also contain Mos2 to ensure the grease can handle shock loads. The enhancement of PAO synthetic base oil allows the grease to be pumped and perform in lubrication systems at much lower temperatures.

PERFORMANCE FEATURES

HIGH BASE OIL VISCOSITY TO PROVIDE EXCELLENT LOAD CARRYING PERFORMANCE

- Meets the recommended base oil viscosity recommended by leading OEMs.

EXCELLENT MECHANICAL STABILITY EVEN UNDER VIBRATING CONDITIONS

- Consistency retained over long periods, even in conditions of severe vibration.

ENHANCED EXTREME PRESSURE PROPERTIES AND RESISTANT TO SHOCK LOADS

- Excellent load-carrying performance enhanced by the presence of Mos2.

EXCELLENT WATER RESISTANCE

- Ensures lasting protection even in the presence of large amounts of water.

EFFECTIVE CORROSION PROTECTION

- Helps to ensure components/bearings do not fail due to corrosion.

HIGH DROPPING POINT

- Resistant to high temperatures.

APPLICATIONS

Shell Gadus S4 V460D Greases are used for the grease lubrication of heavy-duty, slow moving pins and bushes and bearings subject to shock loads found in the following industries:

- Mining
- Steel.

RE-GREASING INTERVALS

For bearings operating near their maximum recommended temperatures, re-greasing intervals should be reviewed.

SPECIFICATIONS, APPROVALS AND RECOMMENDATIONS

LISTED BY THE FOLLOWING OEMS:

- Komatsu
- Komatsu Trucks
- Terex
- Liebherr Trucks
- P&H
- BE (certified).

EXCEEDS THE SPECIFICATIONS OF:

- Caterpillar.

TYPICAL PHYSICAL CHARACTERISTICS

CHARACTERISTICS	2
Colour	Black
Soap Type	Lithium/Complex
Base Oil Type	Mineral/Syn
Kinematic Viscosity (IP 71/ASTM D 445) @ 40°C mm ² /s	460
@ 100°C mm ² /s	32.0
Cone Penetration worked @ 25°C 0.1mm (IP 50/ASTM D 217)	265–295
Dropping Point °C (IP 396)	250
4 Ball Weld Load kg (ASTM D 2596)	620

SHELL GADUS S4 OG CLEAR OIL 20000

ADVANCED OPEN GEAR AND WIREROPE LUBRICANT

DESIGNED TO MEET CHALLENGES

Shell Gadus S4 OG Clear Oil 20000 is an advanced part-synthetic, non-bitumastic viscous lubricant specifically developed to satisfy the demands of heavily loaded open gearing.

PERFORMANCE FEATURES

HIGH VISCOSITY

- The very high viscosity of Shell Gadus S4 OG Clear Oil 20000 has been achieved by combining synthetic oil with thickening effect and high viscosity mineral oils. The use of synthetic oil with thickening effect has also produced a lubricant with high viscosity index, which provides good pumpability at low temperatures while maintaining high viscosity at elevated temperatures.

GEAR INSPECTIONS

- Static and dynamic inspections are much easier to view the gear condition without cleaning off the grease or oil as the lube film is clear and you can inspect the gearing through the lube film.

EXTREME PRESSURE PERFORMANCE

- The high viscosity base oils are combined with extreme pressure additives to give the lubricant very high film strength and extreme load carrying capability needed for the protection of heavily loaded open gearing.

PUMPABILITY

- Shell Gadus S4 OG Clear Oil 20000 can be applied in automatic lubrication systems previously used for bitumastic lubricants (e.g. Farval, Wakefield, Tecalmit and Lincoln). The viscous oil nature of the lubricant allows it to be gravity fed into equipment centralised lubricators if required.

APPLICATIONS

Developed specifically for the lubrication of medium-size to large girth gear drives.

It provides good adhesion, excellent resistance to high pressure and protection against wear.

Shell Gadus S4 OG Clear Oil 20000 incorporates synthetic oil with thickening effect and high viscosity mineral oils blended with extreme pressure additives to give a modern high performance open gear lubricant.

RE-GREASING INTERVALS

For bearings operating near their maximum recommended temperatures, re-greasing intervals should be reviewed.

TYPICAL PHYSICAL CHARACTERISTICS

CHARACTERISTICS	
Base Oil Type	Semi-Synthetic
Kinematic Viscosity (IP 71/ASTM D 445)	
@ 40°C mm ² /s	20,000
@ 100°C mm ² /s	500
4 Ball Weld Load N (ASTM D 2596)	8000
Flash Point °C	220
Pour Point °C	-5
FZG Scuffing Load Stage	>12

SHELL GADUS S5 T100

ADVANCED MULTI-PURPOSE GREASE

PREVIOUSLY SHELL STAMINA RLS



DESIGNED TO MEET CHALLENGES

Shell Gadus S5 T100 Grease is a very high technology grease designed to give optimum performance for grease lubrication in industrial bearings.

It is based on synthetic oil with a special diurea thickener to give long life, low wear and shear-stable properties at high temperatures.

PERFORMANCE FEATURES

- Outstanding life at high temperatures
- Excellent wear protection
- Excellent mechanical stability at high temperatures
- Excellent oxidation resistance
- Low oil separation
- Versatile.

EXCELLENT CORROSION RESISTANCE

- Provides protection from the elements of corrosion.

WATER RESISTANT

- Withstands washing with water, preventing loss of protection.

APPLICATIONS

Shell Gadus S5 T100 Grease is particularly recommended for use in high temperature up to 180°C, lightly loaded industrial bearings. It is recommended for use where long operational life and extended re-greasing intervals are an important consideration.

HIGH TEMPERATURE PERFORMANCE

The diurea thickener used in Shell Gadus S5 T100 has a high melting point and the grease performance is limited only by the properties of the base oil and additive components.

The low volatility and excellent oxidation stability of the base oil are such that they give an excellent service life in bearings operating between -40°C and 180°C.

With caution, Shell Gadus S5 T100 Grease may, in some circumstances, be used at temperatures up to 200°C, but only if the re-lubrication period is suitably adjusted.

OXIDATION STABILITY

Shell Gadus S5 T100 has a superior high temperature oxidation inhibitor system to ensure that it will withstand high operating temperatures without forming deposits. Unlike the soap thickeners used in most greases, the diurea thickener in Shell Gadus S5 T100 does not catalyse grease oxidation, indeed the diurea thickener offers inherent anti-oxidant properties. This contributes to longer grease life at higher temperatures.

The base oil part of Shell Gadus S5 T100 is a specially selected synthetic component with excellent oxidation and evaporation resistance.

CORROSION PROTECTION

When a bearing is running, most high quality greases can maintain an adequate lubricating film even when the grease is contaminated with water. However, when the grease bearing is idle corrosion may occur causing pitting which can be detrimental. Shell Gadus S5 T100 is formulated with corrosion inhibitors to help protect bearing surfaces even when the grease is contaminated by water.

The lubrication properties of Shell Gadus S5 T100 is unimpaired by small quantities of salt water.

Grease life varies considerably from application to application, even with bearings operating under nominally identical conditions. Variables such as air flow, dirt and humidity can have a considerable effect in addition to the more commonly recognised parameters of load, speed and temperature.

The use of Shell Gadus S5 T100 usually permits considerable extension of the re-lubrication interval.

SEALING

The rheology of Shell Gadus S5 T100 is such that at low shear rates and with heating the consistency increases. Consequently, in bearings operating at high temperatures the grease remains in place providing good sealing and continuous lubrication even in the presence of vibration.

WATER WASHOUT

Shell Gadus S5 T100 exhibits very good resistance to water washout by immersion or spray.

TYPICAL PHYSICAL CHARACTERISTICS

CHARACTERISTICS	2
Colour	Brown
Soap Type	Polyurea
Base Oil Type	Synthetic
Kinematic Viscosity (IP 71/ASTM D 445) @ 40°C mm ² /s	100
@ 100°C mm ² /s	14
Cone Penetration Worked @ 25°C 0.1mm (IP 50/ASTM D 217)	265-295
Dropping Point °C (IP 132/ASTM D 566-76)	250
FAG FE-9 Test L50 hrs @ 180°C	>100
Pumpability (long distance)	Fair

SHELL GADUS S5 T460

ADVANCED MULTI-PURPOSE HEAVY-DUTY GREASE

PREVIOUSLY SHELL STAMINA HDS



DESIGNED TO MEET CHALLENGES

Shell Gadus S5 T460 is a high performance, high-temperature, long life grease for heavy-duty industrial applications. It uses fully synthetic base stocks and the latest technology diurea thickener. It contains the latest additives to offer excellent high temperature oxidation performance and other additives to enhance its anti-oxidation, anti-wear and anti-corrosion properties.

Shell Gadus S5 T460 is especially suitable for sealed and semi-sealed applications involving slow moving, heavy-duty bearings operating at high temperatures and under severe loads.

PERFORMANCE FEATURES

HIGH BASE OIL VISCOSITY TO MEET LEADING OEM REQUIREMENTS FOR SLOW MOVING LARGE BEARINGS

- Based upon the latest diurea grease technology proven in steel, paper, wind mills and other industries.

EXCELLENT RESISTANCE TO HIGH TEMPERATURES AND 'HEAT SOAK'

- Synthetic base stocks combined with the inherent oxidation resistance of the diurea thickeners combine to give class leading performance in this area.

ENHANCED EXTREME PRESSURE PROPERTIES

- Excellent load-carrying performance.

EXCELLENT WATER RESISTANCE

- Ensures lasting protection even in the presence of large amounts of water.

HIGH DROPPING POINT

- Resistant to high temperatures.

EFFECTIVE CORROSION PROTECTION

- Helps to ensure components/bearings do not fail due to corrosion.

APPLICATIONS

- Steel, paper, aluminium, chemical, wind power.
- Heavy-duty slow moving plain and rolling element bearings operating in the severe environment, especially when semi or fully sealed for life.

SPECIFICATIONS, APPROVALS AND RECOMMENDATIONS

IS RECOMMENDED FOR USE:

- 40°C to 180°C.

TYPICAL PHYSICAL CHARACTERISTICS

CHARACTERISTICS	1.5
Colour	Light Brown
Soap Type	Diurea
Base Oil Type	Fully-Synthetic
Kinematic Viscosity @ 40°C mm ² /s	460
Cone Penetration worked @ 25°C 0.1mm (IP 50/ASTM D 217)	295
Dropping Point°C (IP 132)	250
Pumpability (Long distance)	Good

SHELL GADUS S2 OG

SUPERIOR PERFORMANCE OPEN GEAR GREASE

DESIGNED TO MEET CHALLENGES

Shell Gadus S2 OG is a range of a premium quality, full EP lubricants developed for the lubrication and protection of open gears and wire ropes subjected to extremes of ambient temperature and operating conditions. They are a unique blend of high quality paraffinic mineral and synthetic base oils with carefully selected additives to provide optimum performance. Its balanced formulation allows the lubricant to stay soft and pliable over long periods, thus helping to minimise the build-up of lubricant in the roots of the gear teeth.

PERFORMANCE FEATURES

EXCEPTIONAL PHYSICAL AND MECHANICAL STABILITY

- Shell Gadus S2 OG retains its natural protective properties over its long working life.

EXCELLENT ANTI-WEAR PERFORMANCE

- At working temperatures, speeds and pressures, Shell Gadus S2 OG forms a protective cushion between the large gear (girth, bull etc) and pinion teeth.

SUPERB LOAD CARRYING CAPACITY

- Molybdenum disulphide and other solid lubricants combine to reduce tooth contact zone temperatures, reduce gear surface pitting and help alleviate 'stick-slip' conditions.

WATER REPELLENT

- Effectively resists water 'wash-off' by immersion or spray.

CORROSION PROTECTION

- Protects metal surfaces from corrosion in hostile environments such as salt-water conditions. Repels dirt and dust.

APPLICATIONS

- Heavily loaded open gears, particularly those found in grinding mills, kilns, shovels, draglines, ship loaders, stackers and reclaimers and excavator applications. When choosing a product to suit your ambient temperature conditions, always consult with your Shell representative for the appropriate grade.
- Multi service lubricant that can be used as the one grease (multi-purpose and open gear) for the entire machine on most shovels, excavators and draglines (excluding electrical motors bearings).
- Surface dressing of slow moving gears open to the atmosphere.
- Plain bearings, pivot pins/bushings and articulations found in earth moving equipment.
- Mooring, static and slow moving wire ropes including those intermittently immersed in salt water.
- Wide variety of heavy-duty mining and industrial applications.

SPECIFICATIONS, APPROVALS AND RECOMMENDATIONS

APPROVED BY:

- FLSmith (Shell Gadus S2 OG 500, 400, 205)
- Norberg (Shell Gadus S2 OG 400)
- Ferry Capitain (Shell Gadus S2 OG 500, 400, 205)
- Falk (Shell Gadus S2 OG 400)
- Lincoln (All Shell Gadus S2 OG).

TYPICAL PHYSICAL CHARACTERISTICS

CHARACTERISTICS	80	85
Kinematic Viscosity (ISO 3016) (Base Oil) @ 40°C mm ² /s @ 100°C mm ² /s	1600 80	1600 80
Density @ 15°C kg/m ³ (ISO 12185)	1.018	1.070
Flash Point (COC) °C (ISO 2592)	min. 130	min. 130
4 Ball Extreme Pressure Test (ASTM D 2596, ASTM D 2266)	min. 6200	min. 6200
Weld Load N Scar Diameter mm	max. 0.8	max. 0.8
Timken OK Load without solids N (ASTM D 2509)	min. 45	min. 45
Falex Continuous Load Failure N (ASTM D 3233)	min. 20450	min. 20450

SHELL RHODINA GREASE BBZ

HIGH PERFORMANCE, PART-SYNTHETIC GREASE, FOR BEARINGS
SUBJECT TO FRETTING AND FALSE BRINELLING

DESIGNED TO MEET CHALLENGES

Shell Rhodina Grease BBZ is specifically designed for high demanding outdoor applications, in particular when protection against false brinelling and fretting corrosion is required—even at very low temperatures.

PERFORMANCE FEATURES

SHELL RHODINA GREASE BBZ PROVIDES

- Protection and lubrication for a wide range of temperatures and in particular has excellent low temperature behaviour allowing excellent operation even in very cold climates.
- Shell Rhodina Grease BBZ has very good water resistance properties.
- This product was developed on the basis of Shell's long-time experience in protecting blade bearings under operation and during idling.
- It helps to minimise the risk of bearing failures which may be caused during transportation and mounting.
- The combination of selected base oils and additives is designed to provide extended product and equipment life.

APPLICATIONS

Shell Rhodina Grease BBZ is designed for lubrication of specific bearings in windturbines (e.g. blade bearings) and other similar applications. Protection against fretting corrosion, moisture corrosion and false brinelling is provided.

Shell Rhodina Grease BBZ can also be used in bearings operating at very low temperatures (e.g. under arctic conditions).

ADDITIONAL INFORMATION

- It is designed for application in a temperature range from -55°C up to 100°C .

TYPICAL PHYSICAL CHARACTERISTICS

CHARACTERISTICS	1.5
Colour	Light Brown
Soap Type	Calcium
Base Oil Type	Part-Synthetic
Kinematic Viscosity (ISO 3104) @ 40°C mm^2/s @ 100°C mm^2/s	13.0 3.0
Cone Penetration Worked @ 25°C 0.1mm (IP 50/ASTM D 217)	300
Dropping Point $^{\circ}\text{C}$ (IP 396)	145

SHELL ONDINA OILS

MEDICINAL WHITE OILS

DESIGNED TO MEET CHALLENGES

Shell Ondina Oils are highly refined, non-additive, aromatic-free paraffinic white mineral oils complying with the stringent pharmacopoeia purity requirements. Shell Ondina Oils can be used in pharmaceutical, food packaging, cosmetic and other applications, where this high purity is required by legislation or important for the quality of the finished product.

PERFORMANCE FEATURES

HIGH PURITY

- Refined to the highest degree of purity removing all aromatics; consist only of chemically inert n- and iso-paraffin molecules.

OPTIMAL QUALITY CONTROL

- Segregated product lines during production, storage, blending and filling; extensive laboratory control testing.

EXCELLENT STABILITY

- Exceeding oxidation and light stability of standard process oils.

APPLICATIONS

COSMETIC AND PHARMACEUTICALS

- Components in cosmetic creams, lotions, oils and toiletries.

FOOD PACKAGING

- Extender oil in polystyrene and other plastics, price labels.

HYGIENE ARTICLES

- Extender oil in thermoplastic TPE (e.g. SIS, SEPS), TPV and other elastomers.

TECHNICAL APPLICATIONS AND CAR COMPONENTS

- Carrier fluid and extender oil for a variety of high quality applications, where colour and stability is important. Suitable when PVC is replaced by TPE elastomers.

TOYS AND SIMILAR ARTICLES

- Extender oil in TPE elastomers (e.g. SBS, SEBS).

MACHINERY LUBRICATION

- The use of medicinal white oils in direct and indirect food applications. These requirements may deviate from country to country and must be taken into account by the user.

SPECIFICATIONS, APPROVALS AND RECOMMENDATIONS

EXCEEDS SPECIFICATIONS OF:

- European Pharmacopoeia 3rd Edition
- US Pharmacopoeia 29th and 30th Editions
- US FDA §172.878 ('White Mineral Oil') for direct food contact
- US FDA §178.3620(a) for indirect food contact
- FDA specifications, where above specified oils are positively listed e.g.
 - §173.340, §175.105, §175.210
 - §175.230, §175.300, §176.170,
 - §176.180, §176.200, §176.210
 - §177.1200, §177.2260, §177.2600
 - §177.2800, §178.3120, §178.3570
 - §178.3740, §178.3910, §573.680.
- UK 'The Mineral Hydrocarbon in Food Regulations 1966'

TYPICAL PHYSICAL CHARACTERISTICS

CHARACTERISTICS	15	32	68
Kinematic Viscosity @ 40°C mm ² /s	15	32	68
@ 100°C mm ² /s	3.3	5.1	6.5
Density @ 15°C kg/m ³ (ISO 12185)	850	865	865
Flash Point °C (COC) (ISO 2592)	180	210	210
Pour Point °C (ISO 3016)	-12	-12	-12
Colour (Saybolt) (ASTM D 156)	+30	+30	+30
Specifications: Europ Pharmacopoeia 3	Light Liquid Paraffin	Light Liquid Paraffin	Liquid Paraffin
US Pharmacopoeia 23	Light mineral oil	Light mineral oil	Mineral oil
Purity Requirements for Medicinal White Oils acc. Europ. Pharm. 3; US Pharm. 23, 30; US FDA §172.878, FDA §178.3620(a)	Pass	Pass	Pass

SHELL CATENEX OIL S

PARAFFINIC PROCESS OIL

DESIGNED TO MEET CHALLENGES

Shell Catenex Oils S are paraffinic process oils manufactured via the solvent extraction process. They are general purpose process oils as extender or carrier fluids.

TYPICAL PHYSICAL CHARACTERISTICS

CHARACTERISTICS	523	579
Colour (ASTM D 1500)	1.0	5.5
Density @ 15°C kg/m ³ (ISO 12185)	868	905
Refractive Index @ 20°C (ASTM D 1218)	1.478	1.498
Flash Point °C (COC) (ISO 2592)	210	300
Pour Point °C (ISO 3016)	-15	-6
Kinematic Viscosity @ 20°C mm ² /s (ISO 3104)	58	2300
@ 40°C mm ² /s	23	500
@ 100°C mm ² /s	4.5	32.0
Sulphur X-Ray %m/m (ISO 14596)	0.6	1.3
Carbon Type Distribution (DIN 51378)		
C/A S-corr. %	3	6
C/N S-corr. %	28	23
C/P S-corr. %	69	71
Refractive Intercept (RI) (DIN 51378)	1.0450	1.0470
Viscosity Gravity Constant (VGC) (DIN 51378)	0.812	0.819
Aniline Point °C (ISO 2977)	100	122
Clay Gel Analysis (ASTM D 2007)		
polar components %m/m	0.6	3.0
aromatic components %m/m	23.4	48.5
saturated components %m/m	76.0	48.5
Evaporation Loss 22h/107°C %m/m (ASTM D 972)	0.8	<0.1
Noack Volatility 1h/250°C %m/m (ASTM D 5800)	18	-
PCA-Content (DMSO) %m/m (IP 346)	<3	<3

SHELL TONNA S3 M

HIGH PERFORMANCE LUBRICANT FOR MACHINE TOOL SLIDEWAYS

DESIGNED TO MEET CHALLENGES

Shell Tonna S3 M is specially designed for the lubrication of machine tool slides and tables. It is based on highly refined mineral oils and contain additives to enhance its tackiness, anti-wear and stick-slip characteristics. It is specially recommended in cases where high precision and low speed machines are used as well as where there are combined lubrication systems.

PERFORMANCE FEATURES

EXCELLENT FRICTIONAL PROPERTIES

- Specially developed to overcome 'stick-slip' problems with slow moving machine tool slides and tables, allowing more accurate positioning. This provides major benefits of improved surface finish and dimensional accuracy of workpieces.

ADVANCED TECHNOLOGY

- Developed in conjunction with machine tool manufacturers to meet the requirements of the most advanced machine tools using a wide variety of slideway materials.

GOOD SLIDEWAY ADHESION

- Provides strong adhesion to slideway surfaces, resisting wash-off by metalworking fluids.

READY SEPARATION FROM WATER-EXTENDIBLE CUTTING FLUIDS

- Separates readily from water-extendible metalworking oils allowing easy removal by skimming.

EXCELLENT ANTI-WEAR PERFORMANCE

- Provides high levels of anti-wear protection for slideways, gears, bearings and hydraulic system components.

EXCELLENT CORROSION PREVENTION CHARACTERISTICS

- Provides effective protection of machine tool surfaces and components in the presence of water-extendible cutting fluids.

APPLICATIONS

MACHINE TOOL SLIDEWAYS, TABLES AND FEED MECHANISMS

- Developed for use on a wide range of materials used for machine tool slideway surfaces, including cast iron and synthetic materials.

MACHINE TOOL HYDRAULIC SYSTEMS

- Particularly recommended for machines which have a combined hydraulic and slideway lubrication system.

MACHINE TOOL GEARBOXES AND SPINDLES

- Also suitable for gear and headstock lubrication.
- The lower viscosity grade is intended for horizontal slide lubrication (Shell Tonna S3 M 68). For vertical slides use Shell Tonna S3 M 220.

SPECIFICATIONS, APPROVALS AND RECOMMENDATIONS

MEETS THE FOLLOWING SPECIFICATIONS

- ISO 11158
- ISO 6743-4 HM and HG
- ISO 12925-1
- ISO 6743-6 CKC
- ISO 19378
- ISO 6743-13 GA and GB
- DIN CGLP
- Cincinnati Machine P-50 (ISO 220) P-47 (ISO 68).

TYPICAL PHYSICAL CHARACTERISTICS

CHARACTERISTICS	68	220
Kinematic Viscosity (ISO 3104) @ 40°C mm ² /s	68	220
@ 100°C mm ² /s	8.6	19.1
Viscosity Index (ISO 2909)	98	98
Density @ 15°C kg/m ³ (ISO 12185)	879	894
Flash Point °C (COC) (ISO 2592)	225	250
Pour Point °C (ISO 3016)	-24	-15

SHELL DRAGLINE ROPE OIL XPL

HIGH PERFORMANCE WIRE ROPE LUBRICANT FOR DRAGLINES

DESIGNED TO MEET CHALLENGES

Shell Dragline Rope Oil XPL is a premium quality, high performance wire rope lubricant developed specifically for the protection and lubrication of running wire ropes on large walking draglines operating in the Australian coal mining industry.

Shell Dragline Rope Oil XPL is a carefully balanced formulation of highly refined paraffinic base oils blended with selected performance-enhancing additives designed to prolong the life of hard working dragline wire ropes.

PERFORMANCE FEATURES

This oil has specifically been formulated to penetrate between the wire rope strands to ensure adequate lubrication of the rope core. Corrosion preventatives are incorporated in the lubricant to minimise corrosion of the steel wires which can reduce wire rope life.

The specially refined paraffinic base oils, compounded with proven extreme pressure additives, gives excellent film forming properties to reduce wire rope wear and strand fretting.

The light viscosity oils added to Shell Dragline Rope Oil XPL ensure the lubricant penetrates deep into the rope core when applied for protection of the inner most wire strands.

Special tackifying additives are blended into the product to provide excellent adhesiveness to the wire rope to reduce fling off when the rope travels at high speeds over sheaves.

- Reduces corrosion, fatigue and wear of hard working dragline wire ropes helping to extend their life.
- Leaves a transparent oil film on wire ropes for visual inspection.
- Can be applied through automatic lubrication systems.

TYPICAL PHYSICAL CHARACTERISTICS

CHARACTERISTICS	
Appearance	Clear Bright Red
Viscosity @ 40°C mm ² /s (ASTM D 445)	225*
Density @ 15°C kg/m ³ (ASTM D 4052)	891
Flash Point °C (COC) (ASTM D 93)	>61.5

*Before the addition of hydrocarbon solvent.

SHELL HEAT TRANSFER OIL S2

HIGH PERFORMANCE HEAT TRANSFER FLUID

PREVIOUSLY SHELL THERMIA B

DESIGNED TO MEET CHALLENGES

Shell Heat Transfer Oil S2 is based on carefully selected, highly refined mineral oils chosen for their ability to provide superior performance in indirect closed fluid heat transfer systems.

PERFORMANCE FEATURES

EXTENDED MAINTENANCE INTERVALS

- Shell Heat Transfer Oil S2 is based on carefully selected highly refined mineral oils and resists oil cracking, oxidation and thickening. This provides extended oil life, provided efficient fluid heating and good pump circulation is ensured, such that film temperatures on the heater surface do not exceed the limits below.

SYSTEM EFFICIENCY

- Low viscosity enables excellent fluidity and heat transfer over a wide temperature range.
- Shell Heat Transfer Oil S2 also has a low vapour pressure so resists cracking. This minimises the formation of volatile decomposition products; these would require recovery via expansion chamber and condensate collector.

WEAR PROTECTION

- Shell Heat Transfer Oil S2 is non-corrosive and has high solvency; this helps to reduce deposit formation by holding oxidation products in solution and keeping internal surfaces of heat exchangers clean.

APPLICATIONS

ENCLOSED CIRCULATED HEAT TRANSFER SYSTEMS

- For industrial applications such as process industry, chemical plants, textile producers and in household equipment such as oil filled radiators.
- Shell Heat Transfer Oil S2 can be used in high temperature continuous heat transfer equipment with the following application limits:
Maximum film temperature = 340°C
Maximum bulk temperature = 320°C

ADVICE

- The life of Shell Heat Transfer Oil S2 depends on the design and usage of the system. If the system is well designed and not subjected to abnormal workloads, the life can be for many years.
- It is important to monitor oil condition regularly as rates of change in physical characteristics are more significant than actual values. The properties that should be monitored are viscosity, acidity, flash point (open and closed) and insolubles content.

SPECIFICATIONS, APPROVALS AND RECOMMENDATIONS

TYPICALLY MEETS THE REQUIREMENTS

- DIN 51522
- Classified as ISO 6743-12 Family Q.

TYPICAL PHYSICAL CHARACTERISTICS

CHARACTERISTICS

Kinematic Viscosity (ISO 3104)		
@ 0°C mm ² /s		223
@ 40°C mm ² /s		25
@ 100°C mm ² /s		4.7
@ 200°C mm ² /s		1.1
Density @ 15°C kg/m ³ (ISO 12185)		866
Flash Point °C	(PMCC) (ISO 2719)	210
	(COC) (ISO 2592)	220
Fire Point °C (COC) (ISO 2592)		255
Pour Point °C (ISO 3016)		-12
Initial Boiling Point °C (ASTM D 2887)		355
Autoignition Temperature °C (DIN 51794)		360
Neutralisation Value mg KOH/g (ASTM D 974)		<0.05
Ash (Oxid) %m/m (ISO 6245)		<0.01
Carbon Residue (conradson) %m/m (ISO 10370)		0.02
Copper Corrosion (3h/100°C) (ISO 2160)		class 1

TYPICAL DESIGN DATA

TEMPERATURE °C	0	20	40	100	150	200	250	300	340
Density kg/m ³	876	863	850	811	778	746	713	681	655
Specific Heat Capacity kJ/kg*K	1.809	1.882	1.954	2.173	2.355	2.538	2.72	2.902	3.048
Thermal Conductivity W/m*K	0.136	0.134	0.133	0.128	0.125	0.121	0.118	0.114	0.111
Prandtl No.	3375	919	375	69	32	20	14	11	9

SHELL PAPER MACHINE OIL S3 M

PAPER MACHINE CIRCULATING OILS

PREVIOUSLY SHELL DELIMA S

DESIGNED TO MEET CHALLENGES

Shell Paper Machine Oil S3 M are high performance oils based on modern ashless additive technology.

PERFORMANCE FEATURES

GOOD OIL LIFE-MAINTENANCE SAVING

- Antioxidant additives provide excellent oil service life with superior performance in the ASTM Turbine Oil Stability Test.
- Very low tendency to form deposits or sludge.

MAINTAINING SYSTEM EFFICIENCY

- Allows easier removal of water. Helps to prevent formation of emulsions in system.
- Good filterability is essential for clean systems and low filter cost.
- Excellent anti-foam and air release properties.

RELIABLE WEAR AND CORROSION PROTECTION

- Helps to prevent wear in the lubricated parts of the paper machine. Zinc-free ashless additive technology.
- High level of corrosion protection for all metal surfaces.

APPLICATIONS

- Shell Paper Machine Oil S3 M has been used in many applications especially in Metso and Voith paper machine circulating systems, including the dry and wet end of the machine along with calender stacks.
- Lubrication of bearings, gears and auxiliary equipment in the wet and drying section of paper machines.
- Hydraulic and lubrication systems in deflection-compensating rolls.
- Maintained protection of gears under severe operating conditions compared to standard circulating mineral oil.
- The bulk temperature of the oil should not continuously exceed 80°C.

COMPATIBILITY AND MISCIBILITY

- Shell Paper Machine Oil S3 M is compatible with seal materials and paints specified for use with mineral oils.

SPECIFICATIONS, APPROVALS AND RECOMMENDATIONS

- Can be used when DIN 51517 Part 2 type oils are required
- FZG: DIN 51354 stage 12 Pass.

MEETS THE REQUIREMENTS OF:

- SKF and METSO requirements for Paper Machine Oils
- Voith VN 108.

TYPICAL PHYSICAL CHARACTERISTICS

CHARACTERISTICS	150	220
Kinematic Viscosity (ASTM D 445) @ 40°C mm ² /s	150	220
@ 100°C mm ² /s	14.8	19.2
Viscosity Index (ISO 2909)	98	98
Density @ 15°C kg/m ³ (ISO 12185)	890	897
Flash Point °C (COC) (ISO 2592)	240	250
Pour Point °C (ISO 3016)	-21	-21
Demulsibility at 82°C (ASTM D 1401) (separation time)	10	10
Rust test, synthetic sea water	Pass	Pass
Oxidation Life (TOST) hrs (ASTM D 943)	3,364	4,378
Timken, OK Load lbs (ASTM D 2782)	50	60

SHELL AIR TOOL OIL S2 A

PNEUMATIC TOOL AND ROCK DRILL OILS

RECOMMENDED REPLACEMENT FOR SHELL TORCULA OIL

DESIGNED TO MEET CHALLENGES

Shell Air Tool Oil S2 A has been developed to meet the special lubrication requirements of pneumatic tools, including percussion type pneumatic tools subjected to the most arduous conditions.

They are designed to maintain high oil film strength and effectively lubricate even the most demanding requirements of pneumatic drill impact mechanisms as well as providing excellent mist lubrication of general purpose air tools.

PERFORMANCE FEATURES

RELIABLE WEAR AND CORROSION PROTECTION

- Shell Air Tool Oil S2 A has been developed to provide excellent lubricity and anti-wear properties to protect percussion tools including rock drills operating under arduous conditions.
- It also helps provide high levels of corrosion protection even under severe water wash conditions.
- The high oil film strength provides for excellent load carrying performance and increased drill life.

MAINTAINING SYSTEM EFFICIENCY

- To ensure efficient lubrication under the full range of operation, Shell Air Tool Oil S2 A has good low temperature fluidity at low temperatures to help provide consistent lubrication and to resist oil build-up in areas cooled by rapid air expansion.
- Shell Air Tool Oil S2 A has excellent emulsability enabling lubrication in a wet environment.

APPLICATIONS

PERCUSSIVE PNEUMATIC TOOLS

- Suitable for a wide range of mobile percussive pneumatic tools such as those used in rock drilling, mining and construction activities (e.g. jack hammers, sinkers and other air operated tools).

OIL MIST LUBRICATION APPLICATIONS

- Shell Air Tool Oil S2 A can also be used in applications requiring mist lubrication, such as air tool installations commonly found in manufacturing.

OTHER APPLICATIONS

- May be used in certain gear and bearing lubrication systems subject to water ingress.

SEAL AND PAINT COMPATIBILITY

- Shell Air Tool Oil S2 A is compatible with seal materials and paints normally specified for use with mineral oils.

SPECIFICATIONS, APPROVALS AND RECOMMENDATIONS

- Meets ISO 6743-11 Types PAC and PBC.

TYPICAL PHYSICAL CHARACTERISTICS

CHARACTERISTICS	100	320
Kinematic Viscosity (ISO 3448) @ 40°C mm ² /s	100	320
@ 100°C mm ² /s	11.5	25.0
Density @ 15°C kg/m ³ (ISO 12185)	884	895
Flash Point °C (COC) (ISO 2592)	241	248
Pour Point °C (ISO 3016)	-24	-18

SHELL NATURELLE HF-E

FULLY-SYNTHETIC BIODEGRADABLE HYDRAULIC FLUIDS

DESIGNED TO MEET CHALLENGES

Shell Naturelle HF-E are advanced biodegradable hydraulic fluids for use in power transmission and hydraulic systems working in environmentally sensitive areas. Synthetic esters blended with specially tailored additive systems provide Shell Naturelle HF-E fluids with a superior balance of biodegradability, lubrication performance and compatibility with the environment.

PERFORMANCE FEATURES

READILY BIODEGRADABLE

- Biodegradable by >60% after 28 days when tested in OECD 301 B (CO₂ evolution test).

LOW ECOTOXICITY

- 'Not Harmful' to algae, invertebrates (Daphnia) and fish; EL₅₀/LL₅₀ >100 mg/l when tested as water-accommodated fractions in OECD 201, OECD 202 and OECD 203.

EXCELLENT VISCOSITY/TEMPERATURE CHARACTERISTICS

- Minimum change of viscosity with variation in operating temperature, giving true 'multigrade' characteristics.

HIGH SHEAR STABILITY

- High shear stability ensures effective lubrication and efficient system operation.

EXCELLENT CORROSION PROTECTION

- Long-term protection for common construction materials, including most metals, non-metals and seal materials such as viton and high nitrile.

GOOD OXIDATION RESISTANCE

- Helps resist the formation of acidic products generated when working at high operating temperatures.

OPTIMUM WEAR PROTECTION

- Effective under all operating conditions, including low and severe duty situations.

APPLICATIONS

- Heavy-duty hydraulic systems for construction and earthmoving equipment
- Machine tool hydraulic systems
- Hydrostatic drive gears
- General industrial control equipment and hydraulic systems
- Moderately rated gearboxes where an anti-wear hydraulic oil is specified.

COMPATIBILITY AND MISCIBILITY

Shell Naturelle HF-E is miscible with conventional mineral oil based hydraulic oils in all proportions. However, in order to ensure that the environmental properties and performance are maintained, the system should be drained and flushed prior to change over to Shell Naturelle HF-E.

Owing to the surface wetting properties of Shell Naturelle HF-E, if systems were previously operated using a mineral oil hydraulic fluid, deposits formed in the system during operation may be loosened and deposited in system filters. The filters should therefore be checked at regular intervals after fluid changeover.

SEAL AND PAINT COMPATIBILITY

Shell Naturelle HF-E is compatible with all seal materials and paints normally specified for use with petroleum mineral oils. Certain plastics and industrial adhesives may be adversely affected and advice should be sought from the respective manufacturers.

SPECIFICATIONS, APPROVALS AND RECOMMENDATIONS

Shell Naturelle HF-E 46 and 68 are on the 'Positivliste' and qualify for funding under the German 'Marketing Introduction Programme' for biolubricants.

The improved anti-wear properties, and naturally high viscosity index (VI) of Shell Naturelle Fluids HF-E, means that they can often be used where ISO 11158 (HM/HV) and DIN 51524 Part 2 or Part 3 (HLP/HVLP) mineral oil hydraulic fluids are specified. However, bulk fluid operating temperatures should not be allowed to exceed 90°C and optimum fluid life will be realised if operating temperatures are maintained at approximately 55°C.

HAS THE APPROVALS OF:

- Eaton Vickers M-2950 S and I-286 S
- ISO 15380 HEES
- VDMA 24568 Synthetic esters.

MEETS OR EXCEEDS THE REQUIREMENTS OF:

- Swedish Standard SS 15 54 34, SP-Listed.

TYPICAL PHYSICAL CHARACTERISTICS

CHARACTERISTICS	46
Colour	Green
Kinematic Viscosity (ISO 3104) @ 40°C mm ² /s	47.2
@ 100°C mm ² /s	9.41
Viscosity Index (ISO 2909)	188
Density @ 15°C kg/m ³	921
Flash Point °C (COC) (ISO 2592)	321
Pour Point °C (COC) (ISO 3016)	-42

SHELL VSI 8235 (CONCENTRATE)

PROTECTS AGAINST RUSTING IN ENCLOSED VAPOUR SPACES

DESIGNED TO MEET CHALLENGES

Shell VSI 8235 (Concentrate) is an oil soluble concentrate that has the ability to protect steel surfaces which are above the normal oil level in a system e.g. the vapour spaces in an oil storage tank or the oil reservoir in a circulation system.

PERFORMANCE FEATURES

- Shell VSI 8235 (Concentrate) contains polar materials which are both oil soluble and also volatile. Thus, as Shell VSI 8235 (Concentrate) is in circulation, the vapour spaces in a system are continuously kept filled with the VSI vapour which is formed by these inhibitors and this vapour continuously blankets metal surfaces to protect them from corrosion.
- Shell VSI 8235 (Concentrate) should be added to the lubricant contained in the sump or in the oil tank a few hours before the equipment is stopped. For new pieces of equipment which will be stored after trial, the lubricant/Shell VSI 8235 (Concentrate) mixture could be totally or partially drained out after the trial run provided however, that a small quantity of mixture is kept in the sump. If the oil temperature remains lower than 25°C, the distance between the upper internal surfaces to be protected and the oil level in the machine must be less than two metres.
- The anti-corrosion performance of the lubricant/Shell VSI 8235 (Concentrate) mixture and the durability of the protection provided are dependent on the degree of ventilation of the system and the oil temperature. The performance can be improved by raising the oil temperature before stopping the equipment and by sealing the vents of the machine concerned.
- The internal protection of large oil tanks will be improved by brushing or spraying the surfaces to be protected with the lubricant/Shell VSI 8235 (Concentrate) mixture.
- Shell VSI 8235 (Concentrate) has no detrimental effects on the individual and special properties of the lubricant to which it is added. The mixture can be used as the service lubricant when the equipment is returned to or put in operation.

WHEN SHELL VSI 8235 (CONCENTRATE) IS USED AT 2% VOLUME SOLUTION IN THE SYSTEM OIL OF EQUIPMENT TO BE PROTECTED, IT:

- Enhances the anti-corrosion performance of the lubricant it is added to.
- Provides corrosion protection of enclosed spaces above the lubricant level by blanketing the metal surfaces to be protected by means of volatile corrosion inhibitors.

APPLICATIONS

Shell VSI 8235 (Concentrate) is an oil soluble concentrate that has the ability to protect steel surfaces which are above the normal oil level in a system – the vapour spaces in an oil storage tank or the oil reservoir in a circulation system would be examples.

Shell VSI 8235 (Concentrate) is recommended for use in all enclosed oil lubrication systems where rusting is likely to occur because of the presence of steam condensate or atmospheric moisture in the system.

TYPICAL APPLICATIONS ARE:

- Oil lubricated rolling bearing and gear housings, reservoirs, oil piping, and similar circulation system components.
- Machine tool housings where the machines may be idle over a weekend or for even longer periods of time.
- Steam turbine lubrication systems where corrosion of oil gravity tanks or oil storage tank walls and overheads is occurring.
- Any machinery that is actually idle or in intermittent use and which is therefore susceptible to rusting because the oil in use gradually drains down from internal surfaces.

RECOMMENDED DOSAGE

Shell VSI 8235 (Concentrate) is recommended for use at 2% volume solution and is added to the existing oil already in the equipment. It should not be used at higher concentrations as this may result in equipment damage.

TYPICAL PHYSICAL CHARACTERISTICS

CHARACTERISTICS	100
Density @ 15°C kg/m ³ (ASTM D 4052/D 1298)	886
Flash Point °C (ASTM D 445)	114
Viscosity @ 40°C mm ² /s (ASTM D 445)	21
TAN mg/KOH/g (ASTM D 664)	32
Total Base Number mg/KOH/g (ASTM D 2896)	30