

## SHINDAIWA OWNER'S/OPERATOR'S MANUAL

# T242 Trimmer



### **WARNING!**

Minimize the risk of injury to yourself and others! Read this manual and familiarize yourself with the contents. Always wear eye and hearing protection when operating this unit.



### **WARNING!**

The engine exhaust from this product contains chemicals known to the State of California to cause cancer, birth defects or other reproductive harm.

## Introduction

The Shindaiwa 242 Series hand held power equipment has been designed and built to deliver superior performance and reliability without compromise to quality, comfort, safety or durability.

Shindaiwa engines represent the leading edge of high-performance engine technology, delivering exceptionally high power with remarkably low displacement and weight. As an owner/operator, you'll soon discover for yourself why Shindaiwa is simply in a class by itself!

ECHO Inc. reserves the right to make changes to products without prior notice, and without obligation to make alterations to units previously manufactured.

### IMPORTANT!

The information contained in this owner's/operator's manual describes units available at the time of publication.

### NOTE:

Specifications, descriptions and illustrative materials in this literature are as accurate as known at the time of publication, but are subject to change without notice. Illustrations may include optional equipment and accessories, and may not include all standard equipment.

### IMPORTANT!

The operational procedures described in this manual are intended to help you get the most from this unit as well as to protect you and others from harm. These procedures are guidelines for safe operation under most conditions, and are not intended to replace any safety rules and/or laws that may be in force in your area. If you have questions regarding your 242 series hand held power equipment, or if you do not understand something in this manual, your Shindaiwa dealer will be glad to assist you. You may also contact ECHO Inc. at the address printed on the back of this manual.

## Table of Contents

Introduction.....	2	135-Hour Maintenance.....	21
Attention Statements .....	3	Carburetor Adjustment.....	21
Warning and Operational Labels .....	3	Disassemble Trimmer Head .....	22
Safety Instructions .....	4	Remove Trimmer Head .....	22
Emission Control (Exhaust & Evaporative).....	7	Nylon Line Replacement .....	23
Contents .....	7	Storage.....	24
Description.....	8	Troubleshooting Guide .....	25
Assembly .....	10	Specifications .....	28
Fuel.....	12	Warranty statements .....	29
Starting Cold Engine.....	14	Servicing Information.....	32
Starting Warm Engine .....	15	Parts/Serial Number .....	32
Stopping the Engine .....	15	Service.....	32
Operation.....	16	Consumer Product Support.....	32
General Maintenance .....	18	Warranty Registration .....	32
Daily Maintenance .....	18	Additional or Replacement Manuals .....	32
10-Hour Maintenance .....	19		
10/15-Hour Maintenance .....	19		
50-Hour Maintenance .....	20		

## Attention Statements

Throughout this manual are special “attention statements”.



### **DANGER!**

A statement preceded by the triangular attention symbol and the word “DANGER” contains information that should be acted upon to prevent serious injury or death.



### **WARNING!**

A statement preceded by the triangular attention symbol and the word “WARNING” contains information that should be acted upon to prevent serious bodily injury.

### **CAUTION!**

A statement preceded by the word “CAUTION” contains information that should be acted upon to prevent mechanical damage.

### **IMPORTANT!**

A statement preceded by the word “IMPORTANT” is one that possesses special significance.

### **NOTE:**

A statement preceded by the word “NOTE” contains information that is handy to know and may make your job easier.

## Warning and Operational Labels



Read and follow this operator's manual. Failure to do so could result in serious injury.



Beware of thrown or ricocheted objects



Wear eye and hearing protection at all times during operation of this unit. Wear head protection where there is a risk of falling objects.



**WARNING:** Surface can be hot. Always wear gloves when handling this unit.

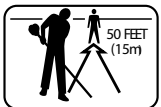

Make sure no one is within 15 m / 50 feet of an operating machine.



Do not use blades.  
String line only

## Safety Instructions

### Personal Condition and Safety Equipment

**WARNING!**

Users of this product risk injury to themselves and others if the unit is used improperly and/or safety precautions are not followed. Proper clothing and safety gear must be worn when operating unit.

### Physical Condition

Your judgment and physical dexterity may not be good:

- if you are tired or sick,
- if you are taking medication,
- if you have taken alcohol or drugs.

Operate unit only if you are physically and mentally well.

**WARNING!**

The ignition components of this machine generate an electromagnetic field during operation which may interfere with some pacemakers. To reduce the risk of serious or fatal injury, persons with pacemakers should consult with their physician and the pacemaker manufacturer before operating this machine. In the absence of such information, ECHO Inc. does not recommend the use of ECHO Inc. products by anyone who has a pacemaker.

### Eye Protection

Eye protection that meets ANSI Z87.1, CE, or CSA Z94.3 requirements must be worn whenever you operate the unit.

### Hand Protection

Wear no-slip, heavy duty work gloves to improve your grip on the handles. Gloves also reduce the transmission of machine vibration to your hands.

### Breathing Protection

Wear a facemask to protect against dust.

### Hearing Protection

ECHO Inc. recommends wearing hearing protection whenever unit is used.

### Proper Clothing

Wear snug fitting, durable clothing:

- Pants should have long legs, shirts with long sleeves.
- DO NOT WEAR SHORTS,
- DO NOT WEAR TIES, SCARVES, JEWELRY, or clothing with loose or hanging items that could become entangled in moving parts or surrounding growth.

Wear sturdy work shoes with nonskid soles:

- DO NOT WEAR OPEN TOED SHOES,
- DO NOT OPERATE UNIT BAREFOOTED.

Wear no-slip, heavy duty work gloves.

Keep long hair away from engine and air intake. Retain hair with cap or net.

### Hot Humid Weather

Heavy protective clothing can increase operator fatigue which may lead to heat stroke. Schedule heavy work for early morning or late afternoon hours when temperatures are cooler.

## Safety Instructions

### Equipment



#### WARNING!

Use only ECHO Inc. approved attachments. Serious injury may result from the use of a non-approved attachment combination. ECHO Inc. will not be responsible for the failure of cutting devices, attachments or accessories which have not been tested and approved by ECHO Inc. Read and comply with all safety instructions listed in this manual.

- Check unit for loose/missing nuts, bolts, and screws. Tighten and/or replace as needed.
- Inspect the debris shield for damage and ensure that the cut-off knife is securely in place. Replace if either is damaged or missing.
- Check that the cutting attachment is firmly attached and in safe operating condition.
- Check that the handle(s) and harness (if included) are adjusted for safe, comfortable operation. See Assembly section for proper adjustment.
- Moving parts can amputate fingers or cause severe injuries. Keep hands, clothing and loose objects away from all openings.
- ALWAYS stop engine, disconnect spark plug, and make sure all moving parts have come to a complete stop before removing obstructions, clearing debris, or servicing unit.
- DO NOT start or operate unit unless all guards and protective covers are properly assembled to unit.
- NEVER reach into any opening while the engine is running. Moving parts may not be visible through openings.
- Check fuel system for leaks due to fuel tank damage, especially if the unit is dropped. If damage or leaks are found, do not use unit, otherwise serious personal injury or property damage may occur. Have unit repaired by an authorized servicing dealer before using.



#### DANGER!

All over head electrical conductors and communications wires can have electricity flow with high voltages. This unit is not insulated against electrical current. Never touch wires directly or indirectly, otherwise serious injury or death may result.

### Read the Manuals

Provide all users of this equipment with the Operator's Manual for instructions on Safe Operation.

### Clear the Work Area

Spectators and fellow workers must be warned, and children and animals prevented from coming nearer than 15 m (50 ft.) while the unit is in use.

### Keep a Firm Grip

Hold both handles with thumbs and fingers encircling the grips.

### Keep a Solid Stance

Maintain footing and balance at all times. Do not stand on slippery, uneven or unstable surfaces. Do not work in odd positions or on ladders. Do not over reach.



## Safety Instructions

### Avoid Hot Surfaces

Keep exhaust area clear of flammable debris. Avoid contact during and immediately after operation.



### WARNING!

During operation the muffler or catalytic muffler and surrounding cover become hot. Always keep exhaust area clear of flammable debris during transportation or when storing, otherwise serious property damage or personal injury may result.

### Vibration and Cold

It is believed that a condition called Raynaud's Phenomenon, which affects the fingers of certain individuals, may be brought about by exposure to vibration and cold. Exposure to vibration and cold may cause tingling and burning sensations, followed by loss of color and numbness in the fingers. The following precautions are strongly recommended because the minimum exposure, which might trigger the ailment, is unknown.

- Keep your body warm, especially the head, neck, feet, ankles, hands, and wrists.
- Maintain good blood circulation by performing vigorous arm exercises during frequent work breaks, and also by not smoking.
- Limit the hours of operation. Try to fill each day with jobs where operating the unit or other hand-held power equipment is not required.
- If you experience discomfort, redness, and swelling of the fingers followed by whitening and loss of feeling, consult your physician before further exposing yourself to cold and vibration.



### Repetitive Stress Injuries

It is believed that overusing the muscles and tendons of the fingers, hands, arms, and shoulders may cause soreness, swelling, numbness, weakness, and extreme pain in those areas. Certain repetitive hand activities may put you at a high risk for developing a Repetitive Stress Injury (RSI). An extreme RSI condition is Carpal Tunnel Syndrome (CTS), which could occur when your wrist swells and squeezes a vital nerve that runs through the area. Some believe that prolonged exposure to vibration may contribute to CTS. CTS can cause severe pain for months or even years.

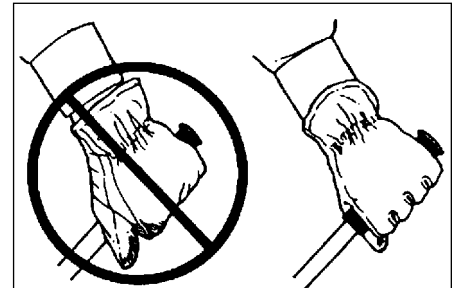

To reduce the risk of RSI/CTS, do the following:

- Avoid using your wrist in a bent, extended, or twisted position. Instead try to maintain a straight wrist position. Also, when grasping, use your whole hand, not just the thumb and index finger.
- Take periodic breaks to minimize repetition and rest your hands.
- Reduce the speed and force with which you do the repetitive movement.
- Do exercise to strengthen the hand and arm muscles.
- Immediately stop using all power equipment and consult a doctor if you feel tingling, numbness, or pain in the fingers, hands, wrists, or arms. The sooner RSI/CTS is diagnosed, the more likely permanent nerve and muscle damage can be prevented.

## Emission Control (Exhaust & Evaporative)

### EPA 2010 and Later and/or C.A.R.B. TIER III

The emission control system for the engine is EM (engine modification) and, if the second to last character of the Engine Family on the Emission Control Information label (sample below) is “C”, “K”, or “T”, the emission control system is EM and TWC (3-way catalyst). The fuel tank/fuel line emission control system is EVAP (evaporative emissions). Evaporative emissions for California models are only applicable to fuel tanks.

EMISSION CONTROL INFORMATION	
ENGINE FAMILY: CEHXS.0214KL	DISPLACEMENT: 21.2cc
EMISSION COMPLIANCE PERIOD: 50 Hours	
THIS ENGINE MEETS 2014 U.S. EPA EXH/EVP & CALIFORNIA EXH/EVP EMISSION REGULATIONS FOR S.O.R.E. REFER TO OWNER'S MANUAL FOR MAINTENANCE SPECIFICATIONS AND ADJUSTMENTS.	
<b>YAMABIKO CORP.</b>	JAN 2014 

EMISSION CONTROL INFORMATION	
ENGINE FAMILY: CEHXS.0214KL	DISPLACEMENT: 21.2cc
EMISSION COMPLIANCE PERIOD: 300 Hours	
THIS ENGINE MEETS 2014 U.S. EPA EXH/EVP & CALIFORNIA EXH/EVP EMISSION REGULATIONS FOR S.O.R.E. REFER TO OWNER'S MANUAL FOR MAINTENANCE SPECIFICATIONS AND ADJUSTMENTS.	
<b>YAMABIKO CORP.</b>	JAN 2014 

An Emission Control Label is located on the engine.  
(This is an EXAMPLE ONLY, information on label varies by engine FAMILY).

#### PRODUCT EMISSION DURABILITY (EMISSION COMPLIANCE PERIOD)

The 50 or 300 hour emission compliance period is the time span selected by the manufacturer certifying the engine emissions output meets applicable emissions regulations, provided that approved maintenance procedures are followed as listed in the Maintenance Section of this manual.

## Contents

The Shindaiwa product you purchased has been factory pre-assembled for your convenience. Due to packaging restrictions, debris shield installation and other assembly may be necessary.

The support handle may need to be re-positioned for comfortable operation.

After opening the carton, check for damage. Immediately notify your retailer or Shindaiwa Dealer of damaged or missing parts. Use the contents list to check for missing parts.

- \_\_\_ - 1 - Power Head / Drive Shaft Assembly
- \_\_\_ - 1 - Debris Shield Assembly
- \_\_\_ - 1 - Trimmer Head
- \_\_\_ - 1 - Trimmer head spacer
- \_\_\_ - 1 - Fixing plate
- \_\_\_ - 1 - Safety Glasses
- \_\_\_ - 1 - Assembly Tool(s)
- \_\_\_ - 1 - Operator's Manual
- \_\_\_ - 1 - Emission Control Warranty Statement
- \_\_\_ - 1 - Warranty Registration Card



### Description

Locate the safety label(s) on your unit. Make sure the label(s) is legible and that you understand and follow the instructions on it. If a label cannot be read, a new one can be ordered from your Shindaiwa dealer. See "Servicing Information" instructions for specific information.

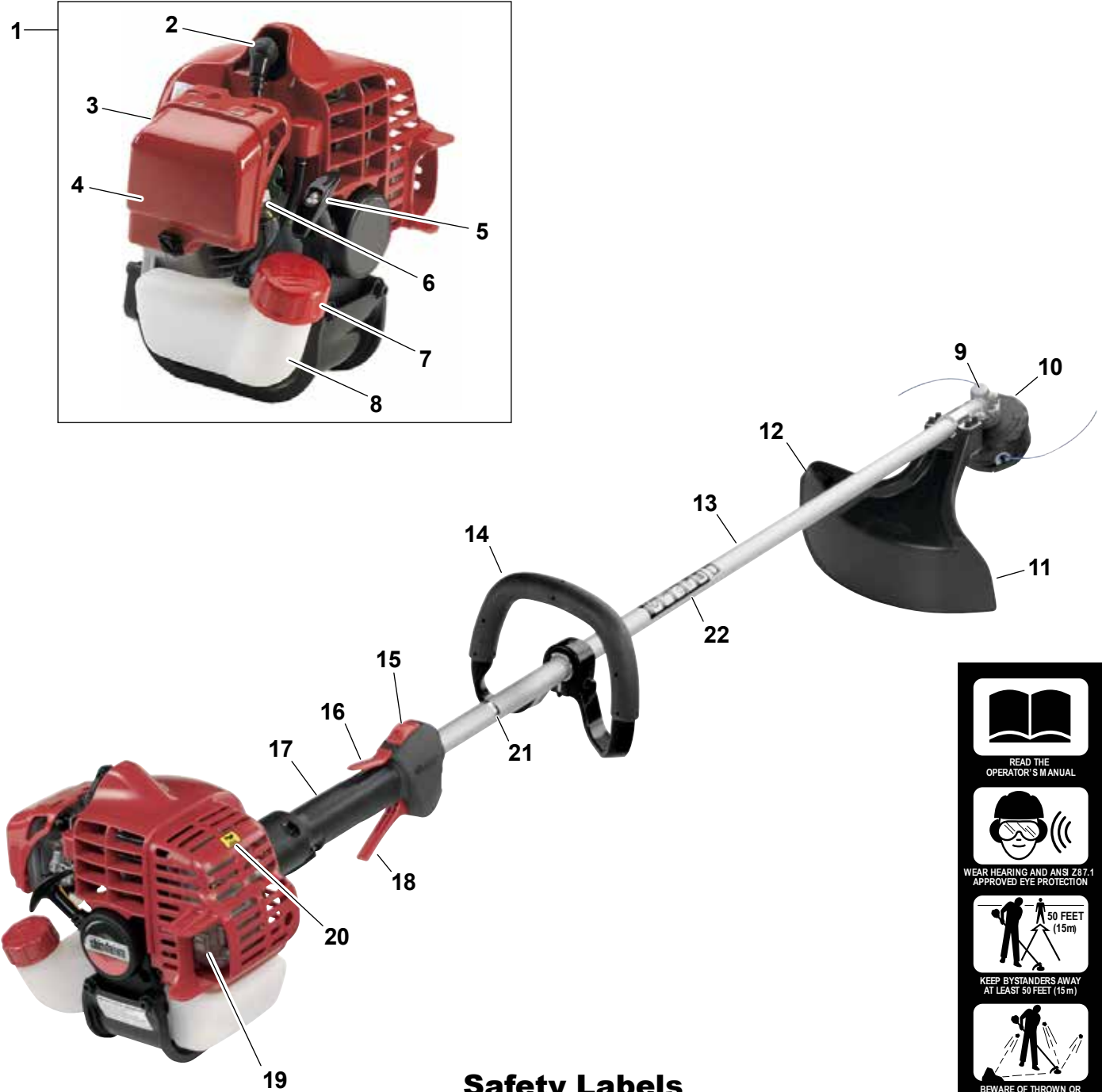

### Safety Labels



20 - Hot Label



21 - Support Handle





22 - Drive Shaft



## Description

---

1. **POWER HEAD** - Includes the engine, clutch, fuel system, ignition system, intake and exhaust systems and recoil starter.
2. **SPARK PLUG** - Provides spark to ignite fuel mixture.
3. **CHOKE LEVER** - Is located on the air filter case. When starting a cold engine, move choke lever to  (Cold Start Position) to close choke. Open choke by moving choke lever to  (Run Position).
4. **AIR FILTER COVER** - Covers replaceable air filter and air filter case
5. **RECOIL STARTER HANDLE** - Pull starter handle slowly until recoil starter engages, then pull quickly and firmly. Return handle slowly. DO NOT let handle snap back or damage to unit will occur.
6. **PURGE BULB** - Pumping purge bulb before starting engine draws fresh fuel from the fuel tank and purges air from the carburetor. Pump purge bulb until fuel is visible and flows freely in the clear, fuel tank return line. Pump purge bulb an additional 4 or 5 times.
7. **FUEL TANK CAP** - Covers and seals fuel tank opening.
8. **FUEL TANK** - Contains the fuel and fuel filter.
9. **GEAR CASE** - Connects the cutting attachment to the unit.
10. **NYLON CUTTER HEAD** - Contains replaceable nylon trimming line that advances when the trimmer head is tapped against the ground while the head is turning at normal operating speed.
11. **DEBRIS SHIELD** - MUST be installed on unit before use, see "Assembly Instructions". Debris shield includes the cut-off knife. The debris shield helps protect the operator by deflecting debris produced during the trimming operation.
12. **CUT-OFF KNIFE** - Automatically trims line to the correct length: 5 inches after head is tapped on the ground. If trimmer is operated without a cut-off knife, the line will become too long, the engine will overheat and engine damage may occur.
13. **DRIVE SHAFT ASSEMBLY** - Includes the right-hand throttle handle, left-hand support handle, drive shaft, main pipe, gear case, and safety labels.
14. **SUPPORT HANDLE - FOR LEFT HAND** - The support handle is loosely assembled to the drive shaft assembly when removed from the carton. The support handle must be positioned and secured for operator comfort and safety.
15. **STOP SWITCH - "SLIDE SWITCH"** mounted on top of the throttle handle.
16. **THROTTLE TRIGGER LOCKOUT** - This lever must be held during starting. Operation of the throttle trigger is prevented unless throttle trigger lockout lever is engaged.
17. **THROTTLE HANDLE - FOR RIGHT HAND** - Contains stop switch, throttle lockout, and throttle trigger.
18. **THROTTLE TRIGGER** - Spring loaded to return to idle when released. During acceleration, press trigger gradually for best operating technique.
19. **SPARK ARRESTOR MUFFLER OR SPARK ARRESTOR MUFFLER WITH CATALYST** - The muffler or catalytic muffler controls exhaust noise and emission. The spark arrestor screen prevents hot, glowing particles of carbon from leaving the muffler. Keep exhaust area clear of flammable debris.

## Assembly

This unit comes fully assembled with the exception of the debris shield, and trimmer head.

### Adjust throttle trigger free play

The throttle trigger free play (A) should be approximately 3/16 - 1/4 inch (4-6 mm). Make sure that the throttle trigger (B) operates smoothly without binding.

If it becomes necessary to adjust the throttle trigger free play (A), perform the procedures that follow.

1. Move Choke Lever (C) to  (D) "Cold Start Position" to close choke. This prevents dirt from entering the carburetor throat when the air filter is removed. Brush accumulated dirt from air filter area.
2. Loosen air filter cover knob (E) and remove the air filter cover (F).
3. Loosen the lock nut (G) on the cable adjuster (H).
4. Turn the cable adjuster (H) in or out as required to obtain proper free play 3/16 - 1/4 inch (4-6 mm).
5. Tighten locknut (G).
6. Reinstall air filter cover (F).

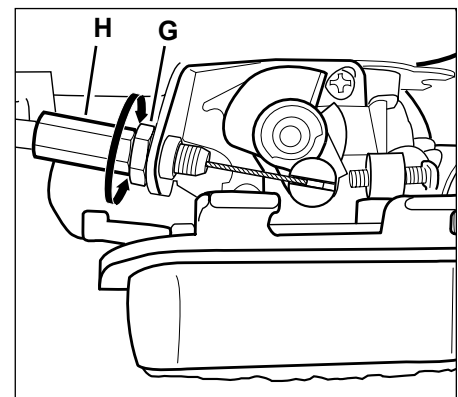
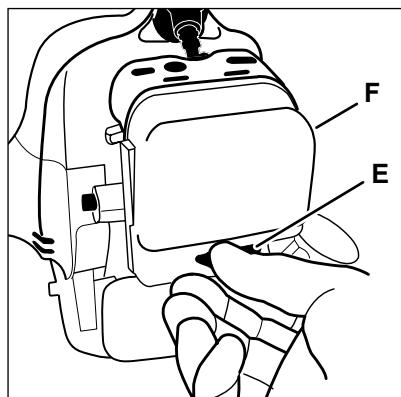
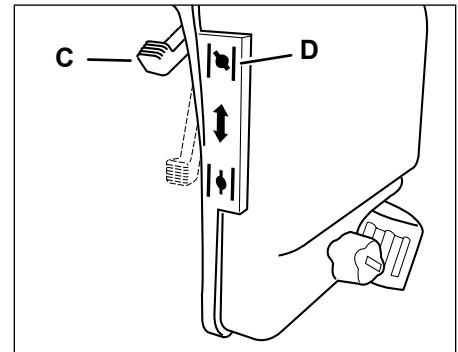
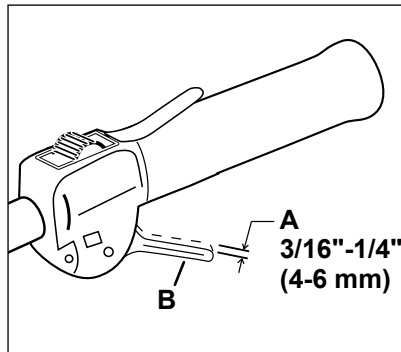

### Install the Debris Shield

1. Place shim (J) on debris shield (K) and insert between the main pipe (L) and mounting plate (M).

#### NOTE:

It may be necessary to loosen the retaining nut (N) and clamp screw (O) to adjust mounting plate (M).

2. Fit shim (P) and bracket (Q) on main pipe (L). Install the four socket-head cap screws (R) and loosely tighten (finger tight).
3. Re-tighten clamp screw (O) and retaining nut (N).
4. Tighten the four socket-head cap screws (R) to secure debris shield (K).

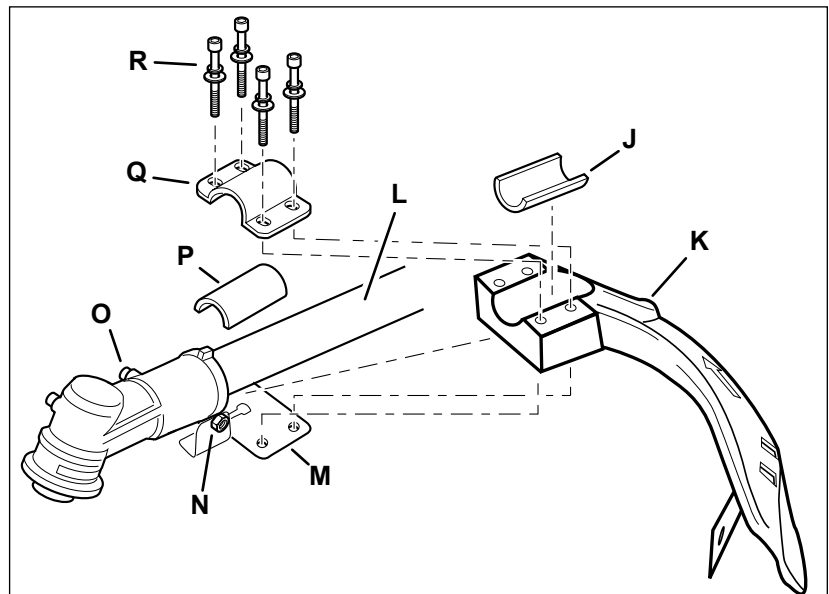

#### WARNING!

NEVER operate the unit without the debris shield installed and tightly secured!

### Assembly

#### Install the Speed-Feed® Trimmer Head

1. Turn the trimmer over so that the gear case output shaft (A) faces UP.
2. Remove and discard the plastic tube (B) from the output shaft (A).
3. Lock gear case by inserting a 4mm hex wrench (C) into locking hole (D).
4. Apply light force to wrench (C) while turning output shaft (A).
5. Continue turning until wrench (C) engages locking notch (E) on underside of holder (F).
6. Hold wrench (C) securely to prevent output shaft (A) from turning.
7. Install fixing plate (H) onto holder.
8. Place nylon spacer (G) on fixing plate (H). Match small (25 mm) diameter recess in nylon spacer (G) to mounting arbor on fixing plate (H).
9. Assemble trimmer head (J) to output shaft (A), turning trimmer head counterclockwise. Tighten trimmer head securely, using hand pressure only.

**NOTE:**

Nylon spacer (G) must stay centered on mounting arbor during tightening.

10. Remove wrench (C).

**IMPORTANT!**

The trimmer head has a left-hand thread. For removal turn the trimmer head clockwise.

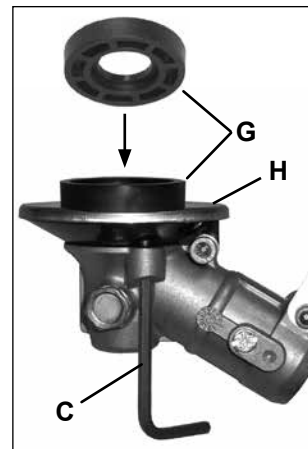
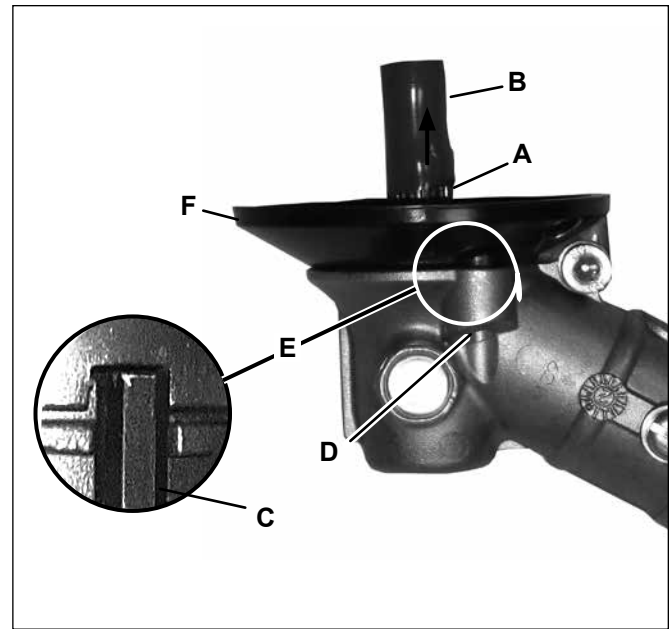

#### To Advance Trimmer Line

To advance trimmer line, tap trimmer head (J) against the ground while the head is turning at normal operating speed.

#### Position the Support Handle

**NOTE:**

Label (A) shows minimum spacing (B) for the support handle location.

1. Position support handle (C) for comfortable operation and secure screw (D).

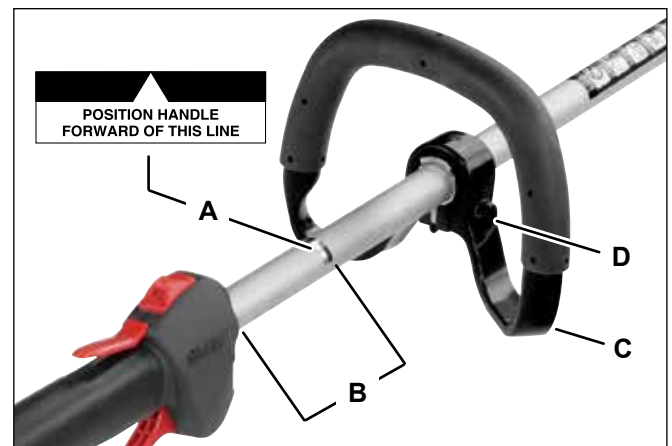

**The unit should now be completely assembled and ready for use.**

## Fuel



### WARNING!

Alternative fuels, such as E15 (15% ethanol), E-85 (85% ethanol) or any fuels not meeting ECHO Inc. requirements are **NOT** approved for use in Shindaiwa gasoline engines. Use of alternative fuels may cause performance problems, loss of power, overheating, fuel vapor lock, and unintended machine operation, including, but not limited to, improper clutch engagement. Alternative fuels may also cause premature deterioration of fuel lines, gaskets, carburetors and other engine components.

## Fuel Requirements

**Gasoline** - Use 89 Octane [R+M/2] (mid grade or higher) gasoline known to be good quality. Gasoline may contain up to 10% Ethanol (grain alcohol) or 15% MTBE (methyl tertiary-butyl ether). Gasoline containing methanol (wood alcohol) is **NOT** approved.

**2 Stroke Mixture Oil** - A 2-stroke engine oil meeting ISO-L-EGD (ISO/CD 13738) and J.A.S.O. M345/FD standards must be used. Shindaiwa One™ 2-Stroke Oil is strongly recommended as it meets this standard and is specifically formulated for use in all Shindaiwa 2-stroke engines. Engine problems due to inadequate lubrication caused by failure to use an ISO-L-EGD (ISO/CD 13738) and J.A.S.O. M345/FD certified oil will void the engine warranty.

For increased engine protection, Shindaiwa recommends using Shindaiwa Red Armor™ engine oil to protect the engine from harmful carbon build up, maintain engine performance, and increase engine life. Shindaiwa Red Armor™ engine oil exceeds ISO-L-EGD and J.A.S.O. M345/FD performance requirements.

### IMPORTANT!

Shindaiwa One™ 2-Stroke oil or Red Armor™ engine oil may be mixed at 50:1 ratio for application in all Shindaiwa engines sold in the past, regardless of ratio specified in those manuals.

## Handling Fuel



### DANGER

Fuel is VERY flammable. Use extreme care when mixing, storing or handling or serious personal injury may result.

- Use an approved fuel container.
- DO NOT smoke near fuel.
- DO NOT allow flames or sparks near fuel.
- Fuel tanks/cans may be under pressure. Always loosen fuel caps slowly to allow pressure to equalize.
- NEVER refuel a unit when the engine is HOT or RUNNING!
- DO NOT fill fuel tanks indoors. ALWAYS fill fuel tanks outdoors over bare ground.
- DO NOT overfill fuel tank. Wipe up spills immediately.
- Securely tighten fuel tank cap and close fuel container after refueling.
- Inspect for fuel leakage. If fuel leakage is found, do not start or operate unit until leakage is repaired.
- Move at least 3m (10 ft.) from refueling location before starting the engine.

## Mixing Instructions

1. Fill an approved fuel container with half of the required amount of gasoline.
2. Add the proper amount of 2-stroke engine oil to gasoline.
3. Close container and shake to mix oil with gasoline.
4. Add remaining gasoline, close fuel container, and remix.

### IMPORTANT!

Spilled fuel is a leading cause of hydrocarbon emissions. Some states may require the use of automatic fuel shut-off containers to reduce fuel spillage.

Fuel to Oil Mix - 50:1 Ratio			
U.S.		METRIC	
GAS	OIL	GAS	OIL
Gallons	Fl. oz.	Liter	cc.
1	2.6	4	80
2	5.2	8	160
5	13	20	400

## Fuel

### After use

- DO NOT store a unit with fuel in its tank. Leaks can occur. Return unused fuel to an approved fuel storage container.

**Storage** - Fuel storage laws vary by locality. Contact your local government for the laws affecting your area. As a precaution, store fuel in an approved, airtight container. Store in a well-ventilated, unoccupied building, away from sparks and flames.

### IMPORTANT!

Stored fuel ages. Do not mix more fuel than you expect to use in thirty (30) days, ninety (90) days when a fuel stabilizer is added. Use of unmixed, improperly mixed, or stale fuel may cause hard starting, poor performance, or severe engine damage and void the product warranty. Read and follow instructions in the Long Term Storage section of this manual.

### IMPORTANT!

Stored two-stroke fuel may separate. ALWAYS shake fuel container thoroughly before each use.

### Filling the fuel tank

#### CAUTION!

Slowly remove the fuel cap only after stopping the engine.

1. Place the unit on a flat, level surface.
2. Clear any dirt or other debris from around the fuel filler cap.
3. Remove the fuel cap (A), and fill the fuel tank with clean, fresh fuel. Do not fill above bottom of fuel tank neck (B).
4. Reinstall the fuel tank cap (A) and tighten firmly.
5. Wipe away any spilled fuel before starting engine.

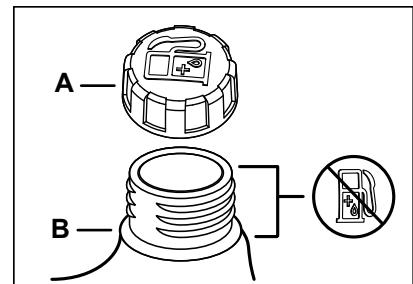

## Starting Cold Engine



### WARNING!

The attachment will operate immediately when the engine starts, and could result in possible serious injury. Keep movable parts of the attachment away from objects that could become entangled or thrown, and surfaces that could cause loss of control.

### IMPORTANT!

Engine ignition is controlled by a two position stop switch mounted on the throttle handle labeled, "I" for ON or START and "O" for OFF or STOP.

#### 1. Stop Switch

Move stop switch (A) away from the STOP position.

#### 2. Choke

Move choke lever (B) to |↵| (C), Cold Start Position.

#### 3. Purge Bulb

Pump purge bulb (E) until fuel is visible and flows freely in the clear fuel tank return line (F). Pump purge bulb an additional 4 or 5 times.

#### 4. Recoil Starter

Lay the unit on a flat area and keep movable attachment parts clear of all obstacles. Firmly grip throttle handle (G) and throttle trigger lockout (H) with left hand and fully depress throttle trigger (J) to wide open position.

Pull starter handle (K) slowly until recoil starter engages, then pull quickly and firmly until engine fires, or maximum five (5) pulls.

### CAUTION!

- Return starter handle (K) slowly. DO NOT let starter handle snap back or damage to unit will occur.
- Do not pull starter handle (K) to the end of the rope travel. Pulling the starter handle to the end of the rope travel can damage the recoil starter.

#### 5. Choke

After engine fires (or 5 pulls), move choke lever (B) to the |↑| (D), Run (open) position. Firmly grasp throttle handle (G) and throttle trigger lockout (H) with left hand and fully depress throttle trigger (J) to wide open position. Pull starter handle (K) until engine starts and runs. Release throttle trigger (J) and allow unit to warm up at idle for several minutes.

### NOTE:

If engine does not start with choke on |↑| (D), Run (open) position, after 5 pulls, repeat instructions 2 - 5.

#### 6. Throttle Trigger

After engine warm-up, grip the throttle handle (G) and support handle. Depress the throttle trigger lockout (H), and gradually depress throttle trigger (J) to increase engine RPM to operating speed.

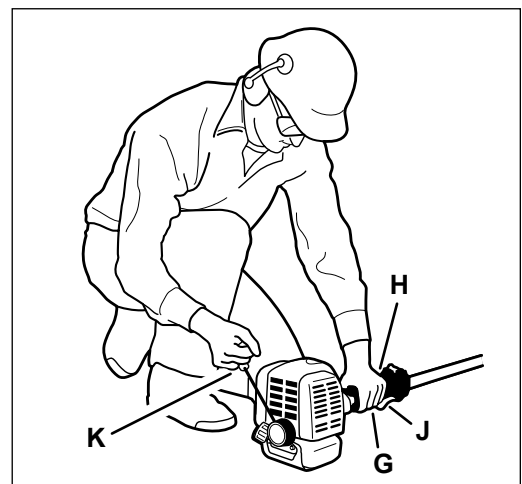
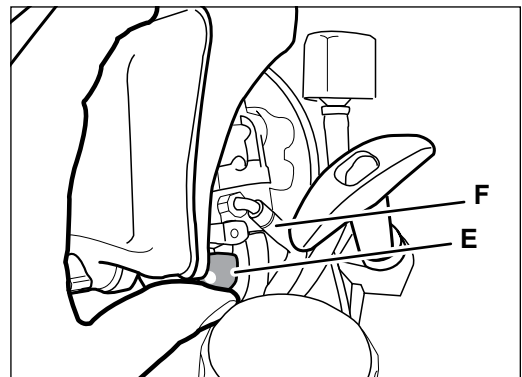
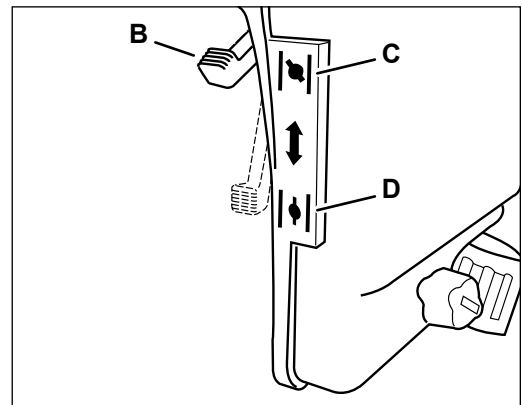
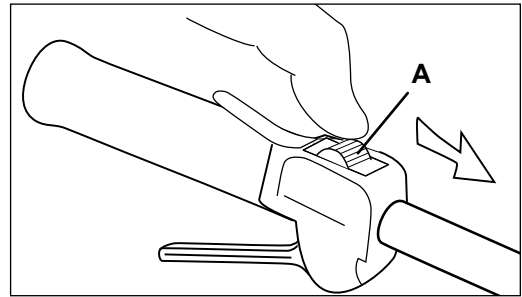



## Starting Warm Engine



### WARNING!

The cutting attachment should not move at idle, otherwise serious personal injury may result.

### NOTE:

If cutting attachment moves, readjust carburetor according to "Carburetor Adjustment: Adjusting Engine Idle" instructions in this manual or see your Shindaiwa Dealer.

The starting procedure is the same as "Starting Cold Engine" except DO NOT move choke lever (B) to  (C), Cold Start Position, and do not depress throttle trigger (J) to wide open position.

### 1. Stop Switch

Move stop switch (A) away from the STOP position.

### 2. Purge Bulb

Pump purge bulb (E) until fuel is visible and flows freely in the clear fuel tank return line (F). Pump purge bulb an additional 4 or 5 times.

### 3. Recoil Starter

Lay the unit on a flat area and keep movable attachment parts clear of all obstacles. Firmly grip throttle handle (G) and throttle trigger lockout (H) with left hand.

Pull starter handle (K) slowly until recoil starter engages, then pull quickly and firmly until engine fires, or maximum five (5) pulls.

### NOTE:

If engine does not start after 5 pulls, use "Starting Cold Engine" procedure.

### CAUTION!

Return starter handle (K) slowly. DO NOT let starter handle snap back or damage to unit will occur.

Do not pull starter handle (K) to the end of the rope travel. Pulling the starter handle to the end of the rope travel can damage the recoil starter.

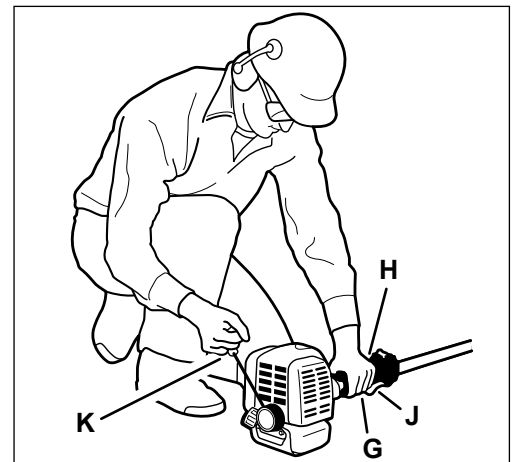
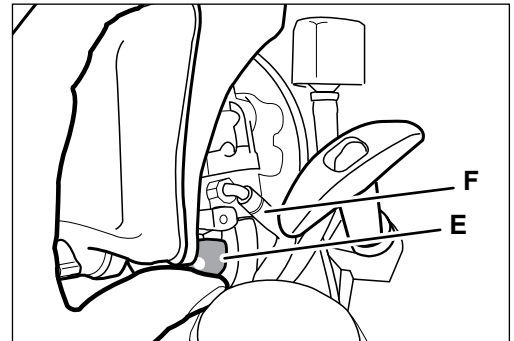
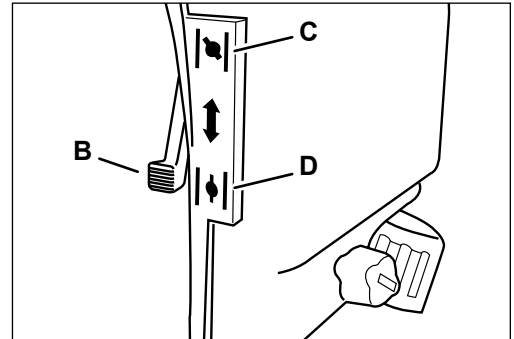
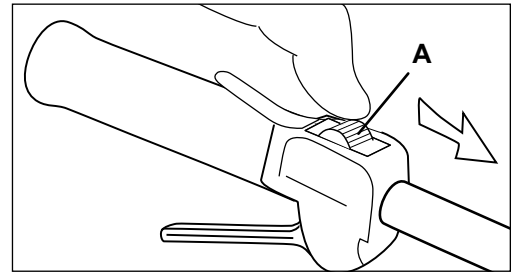

## Stopping the Engine

### 1. Throttle

Release throttle trigger (L) and allow engine to return to idle before shutting off engine.

### 2. Stop Switch

Move stop switch (M) to STOP position.



### WARNING!

If engine does not stop when stop switch is moved to STOP position, move choke lever (B) to  (C), Cold Start Position, to close choke and stall engine. Have your Shindaiwa dealer repair stop switch before using unit again.

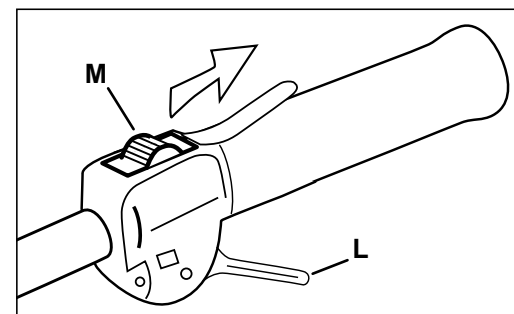



## Operation



### WARNING!

- NEVER operate the unit without the debris shield installed and tightly secured!
- A debris shield or other protective device is no guarantee of protection against ricochet. YOU MUST ALWAYS GUARD AGAINST FLYING DEBRIS!
- ALWAYS make sure the cutting attachment is properly installed and firmly tightened before operation.
- NEVER use a cracked or warped cutting attachment: replace it with a serviceable one.
- ALWAYS make sure the cutting attachment fits properly into the appropriate attachment holder. If a properly installed attachment vibrates, replace the attachment with new one and re-check.
- ALWAYS stop the engine immediately and check for damage if you strike a foreign object or if the unit becomes tangled. Do not operate with broken or damaged equipment.
- NEVER operate a unit with worn or damaged fasteners or attachment holders.
- Engine exhaust IS HOT, and contains Carbon Monoxide (CO), a poison gas. Breathing CO can cause unconsciousness, serious injury, or death. Exhaust can cause serious burns. ALWAYS position unit so that exhaust is directed away from your face and body.
- Operation of this equipment may create sparks that can start fires. This unit is equipped with a spark arrestor to prevent discharge of hot particles from the engine. Metal cutters can also create sparks if the cutter strikes rocks, metal, or other hard objects. Contact local fire authorities for laws or regulations regarding fire prevention requirements.
- A standard grass trimmer with a loop handle should NEVER be operated with blade-type attachments. For blade use the trimmer must be fitted with a bicycle-type handlebar or a barrier bar that is located in front of the operator to reduce the risk of the operator from coming in contact with the cutting attachment (per ANSI B175.3). When using a blade, the unit must also be equipped with a harness or strap.



### DANGER!

Do not operate this product indoors or in inadequately ventilated areas. Engine exhaust contains poisonous emissions and can cause serious injury or death.

### CAUTION!

- Operation of trimmer head without a debris shield and using excessive line length can lead to premature clutch failure.
- Do not push the rotating line into trees, wire fences or any material that could tangle or break line ends

## Operation

### Cutting Grass

#### Units equipped with a trimmer head

Your Shindaiwa unit may be equipped with one of several Shindaiwa trimmer head models, each with features for specific applications and/or operational requirements. For proper operation, always refer to the instructions accompanying the trimmer head being used. Available trimmer head styles include:

- **Semi-automatic.** Trimmer line is advanced when the operator taps the trimmer head on the ground during operation.
- **Manual.** The operator must stop the unit and advances line manually with the grass trimmer stopped.
- **Fixed.** The operator must stop the unit and add new lengths of trimmer line manually.
- **Flail.** This device, designed for clearing weeds and light brush, features three nylon blades attached to the head by pivots.

#### NOTE:

Additional hardware may be required to mount the Fixed Line or the Flail type trimmer heads.

### Trimming and Mowing Grass

Hold the trimmer so the trimmer head is angled slightly into the area to be cut. To ensure maximum trimmer-line service life, cut only with the tip of the trimmer line. Cut grass by swinging the trimmer from left to right. Keep the trimmer head horizontal.

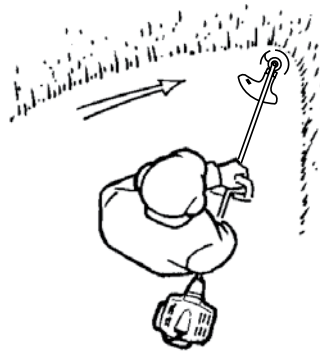

### Edging

Tilt the handle about 100° to the left (from horizontal) and move forward, holding the trimmer vertically as shown.



### Engine Operating Speeds

Operate the unit at full throttle while cutting. Best fuel efficiency is obtained by releasing the throttle when swinging back after a cut.

#### CAUTION!

- Operation at high RPM without a load can lead to engine damage
- Operation at low RPM tends to cause grass and debris to wrap around the cutting attachment.
- Operation at low RPM can lead to premature clutch failure.

### Shoulder Strap or Harness

A shoulder strap or harness gives significant support and comfort to help ensure safe and efficient operation.

## General Maintenance

### IMPORTANT!

MAINTENANCE, REPLACEMENT OR REPAIR OF EMISSION CONTROL DEVICES AND SYSTEMS MAY BE PERFORMED BY ANY REPAIR ESTABLISHMENT OR INDIVIDUAL; HOWEVER, WARRANTY REPAIRS MUST BE PERFORMED BY A DEALER OR SERVICE CENTER AUTHORIZED BY ECHO INC. THE USE OF PARTS THAT ARE NOT EQUIVALENT IN PERFORMANCE AND DURABILITY TO AUTHORIZED PARTS MAY IMPAIR THE EFFECTIVENESS OF THE EMISSION CONTROL SYSTEM AND MAY HAVE A BEARING ON THE OUTCOME OF A WARRANTY CLAIM.

### NOTE:

Using non-standard replacement parts could invalidate your Shindaiwa warranty.



### WARNING!

- Moving parts can amputate fingers or cause severe injuries. Keep hands, clothing and loose objects away from all openings. Always stop engine, disconnect spark plug, and make sure all moving parts have come to a complete stop before removing obstructions, clearing debris, or servicing unit. Allow unit to cool before performing service. Wear gloves to protect hands from sharp edges and hot surfaces.
- Non-standard accessories, cutting attachment, or replacement parts may not operate properly with your unit and may cause damage and lead to personal injury.

### Muffler

This unit must never be operated with a faulty or missing spark arrester or muffler. Make sure the muffler is well secured and in good condition. A worn or damaged muffler is a fire hazard and may also cause hearing loss.

### Spark Plug

Keep the spark plug and wire connections tight and clean.

### Fasteners

Make sure nuts, bolts, and screws (except carburetor adjusting screws) are tight.

## Daily Maintenance

Prior to each work day, perform the following:

1. Remove dirt or debris from the engine (A). Check air filter (B) and cooling fins (C) for clogging and clean them as necessary.
2. Carefully remove any accumulation of dirt or debris from the muffler (D) or the fuel tank (E). Dirt build-up in these areas could cause engine overheating, induce premature wear, or create a fire hazard.
3. Check for loose or missing screws or components. Make sure the cutting attachment is securely fastened.
4. Check the entire unit for leaking fuel or grease.

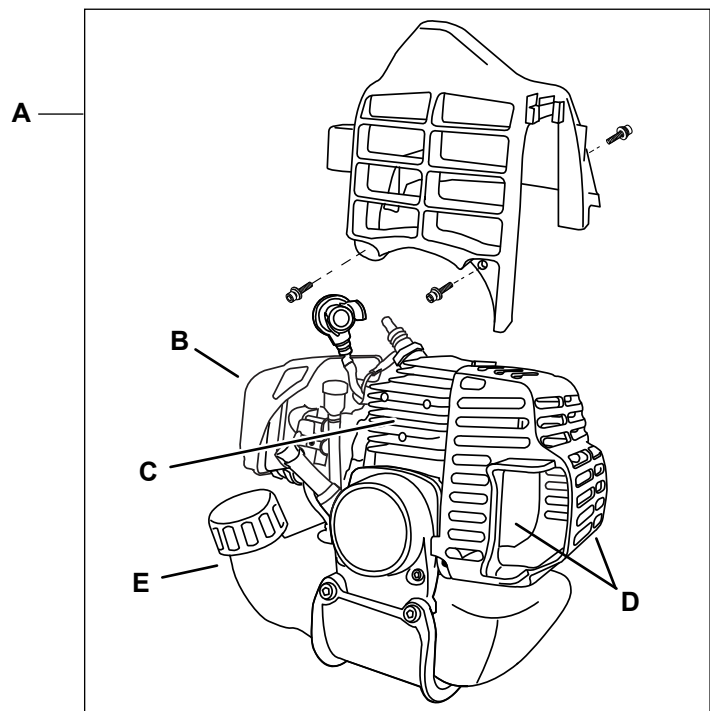

## 10-Hour Maintenance

**Every 10 hours of operation**  
(more frequently in dusty or dirty conditions).

1. Move choke lever (A) to  (B), Cold Start Position, to close choke. This prevents dirt from entering the carburetor throat when the air filter is removed. Brush accumulated dirt from air filter area.
2. Loosen the air filter cover knob (C) and remove the air filter cover (D). Brush dirt from inside cover.
3. Replace air filter (E) if it is damaged, fuel soaked, very dirty, or the rubber sealing edges are deformed.
4. Lightly brush debris from air filter (E). Soak heavily soiled air filter in water/detergent solution to loosen dirt, then brush lightly.
5. Rinse with clean water and allow to dry completely before reuse.
6. Install air filter (E) in air filter case (F).
7. Install air filter cover (D) and tighten air filter cover knob (C) securely.

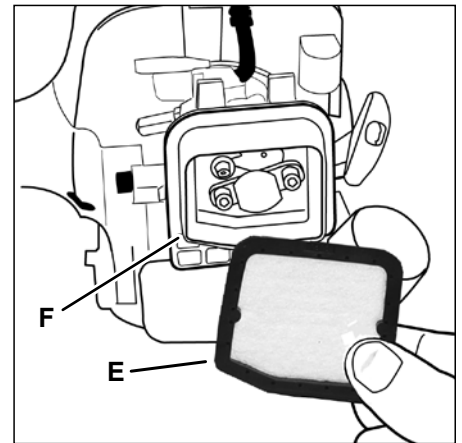
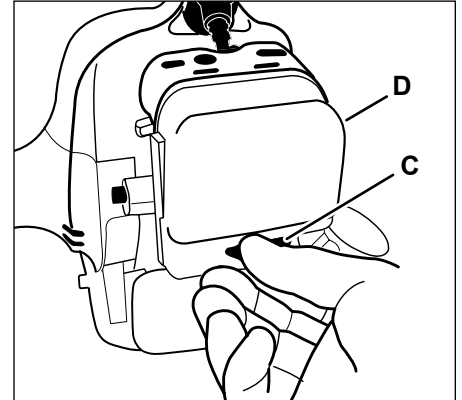
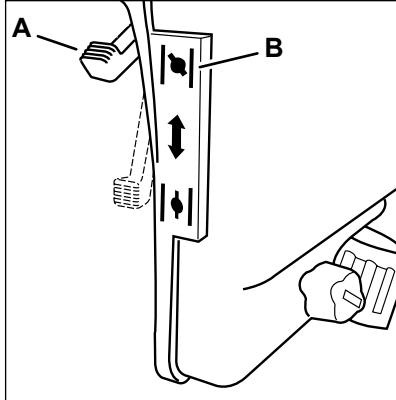

### CAUTION!

Do not operate the unit if the air filter assembly or air filter is damaged, wet or missing

## 10/15-Hour Maintenance

**Every 10 to 15 hours of operation:**

### NOTE:

Use only NGK BPM-8Y spark plug (BPMP-8Y in Canada) otherwise severe engine damage may occur.

1. Remove spark plug (G) and check for fouling, worn and rounded center electrode.
2. Clean the spark plug or replace with a new one. DO NOT sand blast to clean. Remaining sand will damage engine.
3. Adjust spark plug gap (H) to 0.6 mm (0.024 inch) by bending outer electrode (J).
4. Tighten the spark plug to 150-170 kgf • cm (130-150 lbf • in).

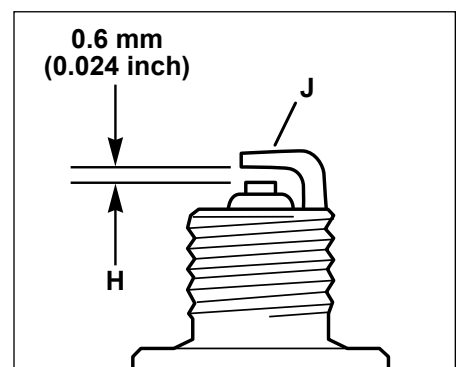
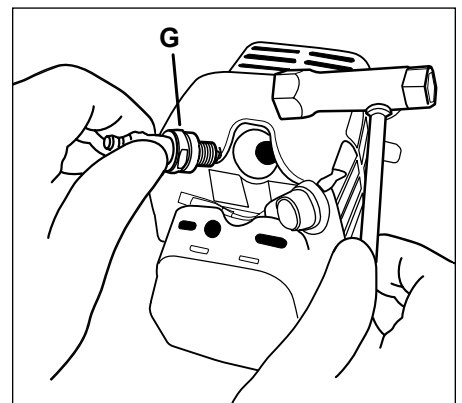

### CAUTION!

Before removing the spark plug, clean the area around the spark plug to prevent dirt and debris from getting into the engine's internal parts.

## 50-Hour Maintenance

### Every 50 hours of operation

(more frequently in dusty or dirty conditions):

1. Remove and clean the engine cover (A) and clean grass and dirt from the cylinder fins (B).

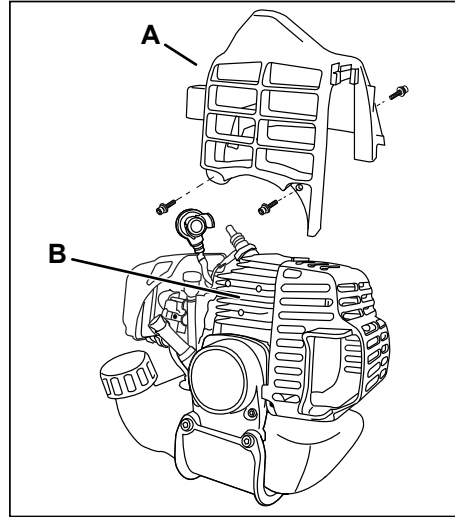

### Gearcase lubrication

2. Clean all loose debris from gear case (C).
3. Remove grease plug (D) and check level of grease.
4. Add grease if necessary. DO NOT overfill.



### Remove and replace the fuel filter



#### **DANGER!**

Fuel is VERY flammable. Use extreme care when mixing, storing or handling, or serious personal injury may result.

5. Use a clean rag to remove loose dirt from around fuel cap and empty fuel tank.
6. Use the "fuel line hook" (E) to pull the fuel line (F) and fuel filter (G) from the fuel tank.
7. Remove the fuel filter (G) from the fuel line (F) and install the new fuel filter.

Before reinstalling the new fuel filter, inspect the condition of all the fuel system components (fuel pick-up line, fuel return line, tank vent line, tank vent, fuel cap and fuel tank). If damage, splitting or deterioration is noted, the unit should be removed from service until it can be inspected or repaired by a Shindaiwa trained service technician.

#### **CAUTION!**

Make sure you do not pierce the fuel line with the end of the hooked wire. The line is delicate and can be damaged easily.

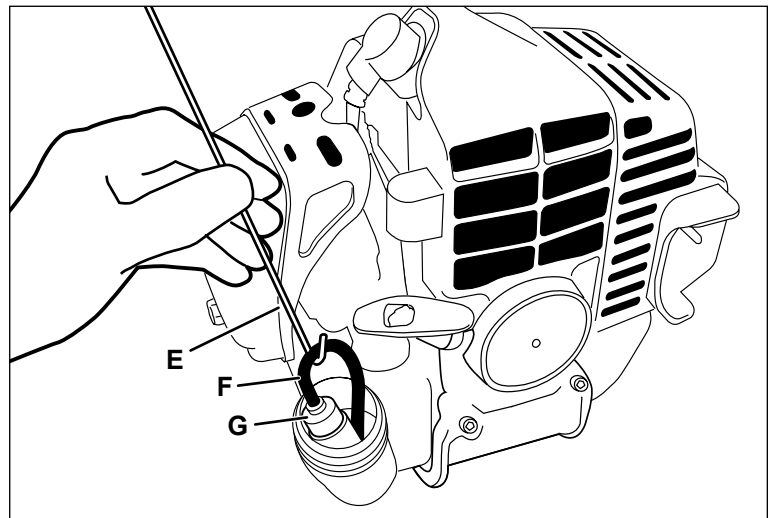

#### **NOTE:**

Federal EPA regulations require all model year 2012 and later gasoline powered engines produced for sale in the United States to be equipped with a special low permeation fuel supply hose between the carburetor and fuel tank. When servicing model year 2012 and later equipment, only fuel supply hoses certified by EPA can be used to replace the original equipment supply hose. Fines up to \$37,500 may be enforced for using a non-certified replacement part.

## 135-Hour Maintenance

Every 135 hours of operation, remove and clean the muffler.



### WARNING!

Never operate this trimmer with a damaged or missing muffler or spark arrester! Operating with missing or damaged exhaust components is a fire hazard, and can also damage your hearing!

1. Remove the spark plug boot (A).
2. Remove the engine cover (B) and muffler cover (C).
3. Remove exhaust parts (D & E), exhaust gasket (F) and spark arrester screen (G).
4. Clean the spark arrester screen (G) with a stiff bristle brush.
5. Remove the 3 muffler bolts and the muffler (H).
6. Inspect the cylinder exhaust port (J) for any carbon buildup.
7. Gently tap the muffler (H) on a wood surface to dislodge any loose carbon.
8. Reassemble in the reverse order of disassembly

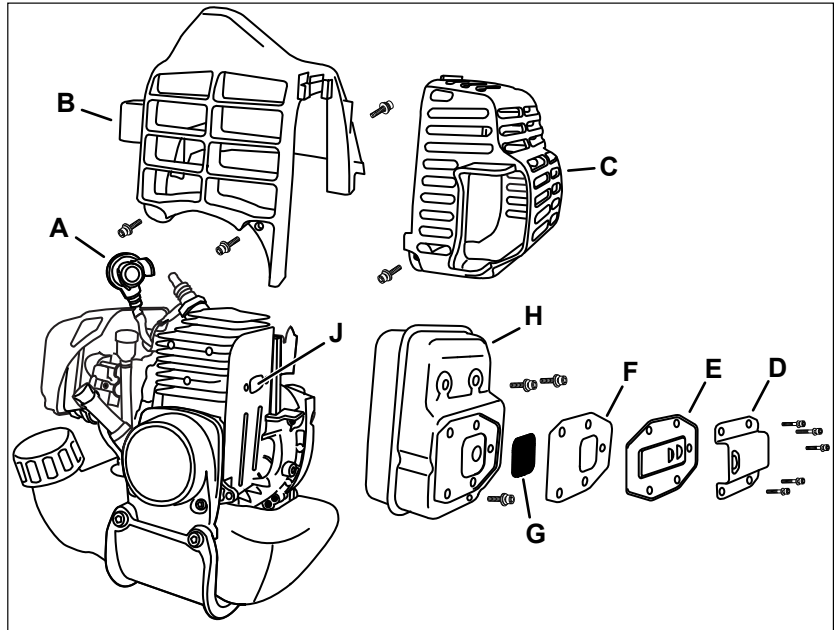

### IMPORTANT!

If you note excessive carbon buildup, consult with an authorized Shindaiwa servicing dealer.

## Carburetor Adjustment

### Engine Break-In

New engines must be operated a minimum duration of two tanks of fuel break-in before carburetor adjustments can be made. During the break-in period your engine performance will increase and exhaust emissions will stabilize. Idle speed can be adjusted as required.

### High Altitude Operation

This engine has been factory adjusted to maintain satisfactory starting, emission, and durability performance up to 1,100 feet above sea level (ASL) (96.0 kPa). To maintain proper engine operation and emission compliance above 1,100 feet ASL the carburetor may need to be adjusted by an authorized Shindaiwa service dealer.

### IMPORTANT!

If the engine is adjusted for operation above 1,100 feet ASL, the carburetor must be re-adjusted when operating the engine below 1,100 feet ASL, otherwise severe engine damage may result.

### NOTE:

Every unit is run at the factory and the carburetor is set in compliance with emission regulations. Carburetor adjustments, other than idle speed, must be performed by an authorized Shindaiwa dealer.



## Carburetor Adjustment

### Adjusting Engine Idle

The engine must return to idle speed whenever the throttle lever is released. Idle speed is adjustable, and must be set low enough to permit the engine clutch to disengage the cutting attachment.

### Idle Speed Adjustment

1. Place the trimmer on the ground, then start the engine. Allow it to idle 2-3 minutes until warm.
2. If the cutting attachment rotates when the engine is at idle, reduce the idle speed by turning the idle speed screw (A) counter-clockwise; clockwise to increase idle speed
3. If a tachometer is available, idle speed screw (A) should be set to the specifications found on the "Specifications" page of this manual.

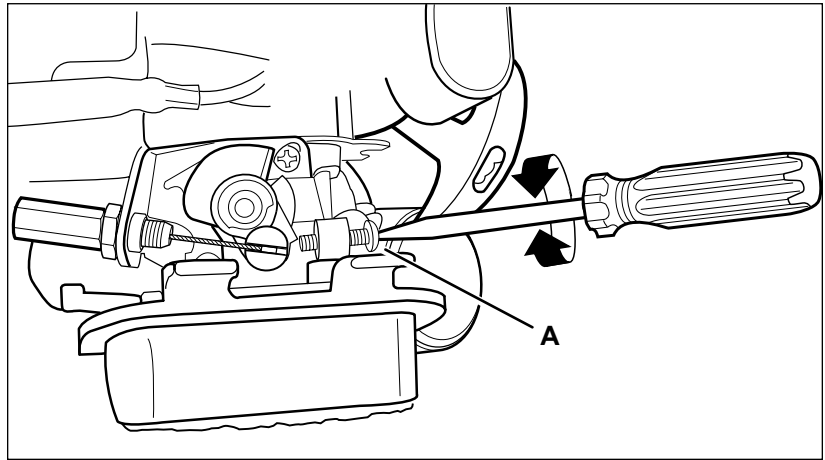

### WARNING!

When carburetor adjustment is completed, the cutting attachment should not move at idle, otherwise serious personal injury may result. If the idle speed cannot be adjusted by the procedure described here, return the trimmer to your Shindaiwa dealer for inspection.

## Disassemble Trimmer Head

### NOTE:

For normal use, Speed-Feed® trimmer head disassembly is not necessary. However, if circumstances require disassembly, follow these instructions.

1. Press top of locking tabs (A) on both sides of Speed Feed® head to release cover (B) from eyelet carrier (C).
2. Remove cover (B) from eyelet carrier (C).

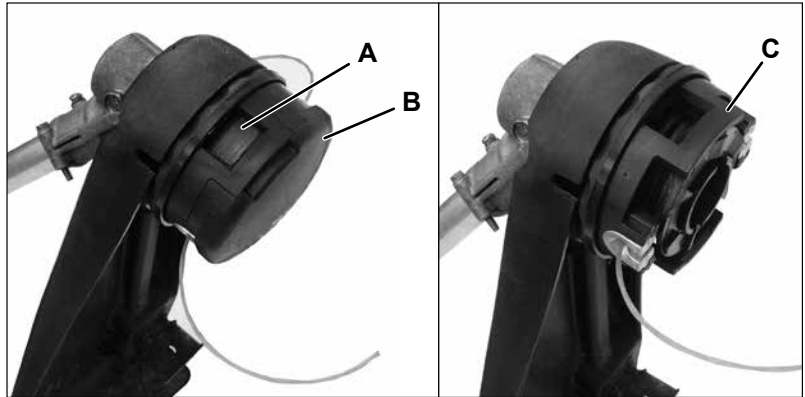

## Remove Trimmer Head

### Note:

Do not disassemble trimmer head.

1. Turn the trimmer over so the trimmer head (D) faces UP.
2. Lock gear case by inserting a 4mm hex wrench (E) into locking hole (F).
3. Apply light pushing force to wrench (E) while turning trimmer head (D).
4. Continue turning until wrench (E) engages locking notch (G) on underside of holder.
5. Hold wrench (E) securely.
6. Remove trimmer head (D) by turning it clockwise until head is completely off of output shaft.
7. Remove wrench (E).

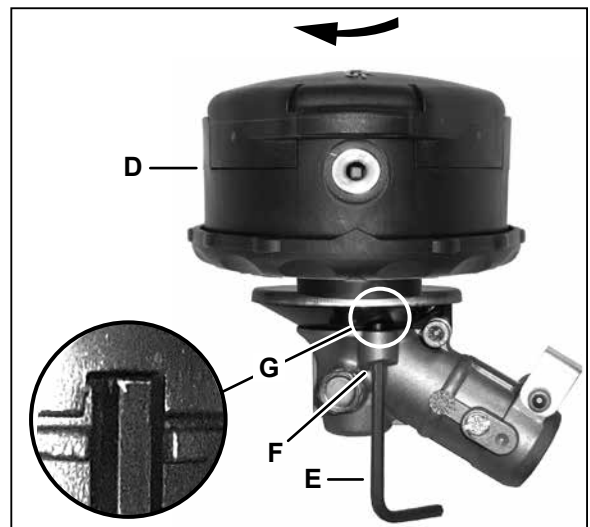



## Nylon Line Replacement



### CAUTION!

Wear gloves or personal injury may result:

- Cutoff knife is sharp.
- Gearcase and surrounding area may be hot.

1. Cut one piece of nylon line to recommended length.
  - .080 (2.0 mm) dia. – 20' (6 m)
  - .095 (2.4 mm) dia. – 20' (6 m)
2. Align arrows on top of knob (A) with openings in eyelets (B).

3. Insert one end of nylon line into an eyelet, and push line equal distance through trimmer head.

4. Hold trimmer head while turning knob (C) clockwise to wind nylon line onto spool until about 5" (13 cm) of each line remains exposed.

**Trimmer head is now fully loaded and ready for operation.**

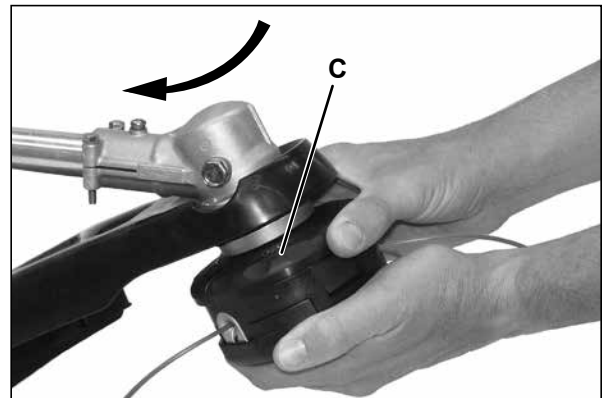
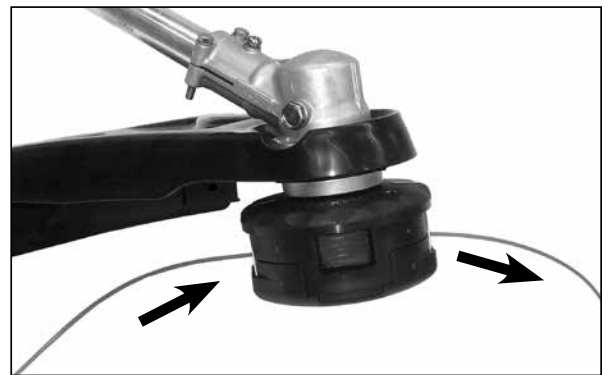

### IMPORTANT!

When the wear indicators (D) located at the bottom of the Speed-Feed® trimmer head are worn smooth, or if holes appear, replacement of the trimmer head cover (E) or the entire Speed-Feed® head is required.



## Storage

### Long Term Storage (over 30 Days)

Do not store your unit for a prolonged period of time (30 days or longer) without performing protective storage maintenance which includes the following:

1. Place the stop switch in the "OFF" position.
2. Remove accumulation of grease, oil, dirt and debris from exterior of unit.
3. Perform all periodic lubrication and services that are required.
4. Repair and replace all worn or damaged parts.
5. Tighten all the screws and nuts.
6. Drain fuel tank completely. Press purge bulb 6 -7 times to remove remaining fuel from carburetor then drain the tank again. Close choke, start and run the engine until it stops due to lack of fuel.
7. a. Allow engine to cool then remove the spark plug and pour 7 cc (1/4 oz.) of fresh, clean, two-stroke engine oil into the cylinder through the spark plug hole.  
b. Slowly pull the recoil starter handle 2-3 times to distribute the oil inside the engine.  
c. Observe the piston location through the spark plug hole. Pull the recoil handle slowly until the piston reaches the top of its travel and leave it there.
8. Install the spark plug (do not connect ignition cable).
9. Store unit in a dry, dust free place, out of the reach of children.

**DANGER!**

Do not store in enclosure where fuel fumes may accumulate or reach an open flame or spark.

## Troubleshooting Guide

### ENGINE DOES NOT START OR HARD TO START

What To Check	Possible Cause	Remedy
Vaporlock.	<ul style="list-style-type: none"> <li>Engine hot/heat soaked.</li> <li>Low fuel quality.</li> </ul>	<ul style="list-style-type: none"> <li>Let cool completely and restart.</li> <li>Refill with fresh, clean unleaded gasoline with a pump octane of 89 or higher mixed with an air cooled engine oil that meets or exceeds ISO-L-EGD (ISO/CD 13738) and J.A.S.O. M345- FD classified oils at 50:1 gasoline/oil ratio.</li> </ul>

### ENGINE DOES NOT START

What To Check	Possible Cause	Remedy
Does the engine crank?	<ul style="list-style-type: none"> <li>Faulty recoil starter.</li> <li>Fluid in the crankcase.</li> <li>Internal damage.</li> </ul>	Consult with an authorized Shindaiwa servicing dealer.
<p>YES</p> <p>↓</p> Good compression?	<ul style="list-style-type: none"> <li>Loose spark plug.</li> <li>Excess wear on cylinder, piston, rings.</li> </ul>	<ul style="list-style-type: none"> <li>Tighten and re-test.</li> <li>Consult with an authorized Shindaiwa servicing dealer.</li> </ul>
<p>YES</p> <p>↓</p> Does the tank contain fresh fuel of the proper grade?	<ul style="list-style-type: none"> <li>Fuel incorrect, stale, or contaminated; mixture incorrect.</li> </ul>	Refill with fresh, clean unleaded gasoline with a pump octane of 89 or higher mixed with an air cooled engine oil that meets or exceeds ISO-L-EGD (ISO/CD 13738) and J.A.S.O. M345- FD classified oils at 50:1 gasoline/oil ratio.
<p>YES</p> <p>↓</p> Is fuel visible and moving in the return line when priming?	<ul style="list-style-type: none"> <li>Check for clogged fuel filter and/or vent.</li> <li>Priming pump not functioning properly.</li> </ul>	<ul style="list-style-type: none"> <li>Replace fuel filter or vent as required. Re-start.</li> <li>Consult with an authorized Shindaiwa servicing dealer.</li> </ul>
<p>YES</p> <p>↓</p> Is there spark at the spark plug wire terminal?	<ul style="list-style-type: none"> <li>The ignition switch is in "O" (OFF) position.</li> <li>Shorted ignition ground.</li> <li>Faulty ignition unit.</li> </ul>	<ul style="list-style-type: none"> <li>Move switch to "I" (ON) position and re-start.</li> <li>Consult with an authorized Shindaiwa servicing dealer.</li> </ul>
Check the spark plug.	<ul style="list-style-type: none"> <li>The plug is fouled or improperly gapped.</li> <li>The plug is damaged internally or of the wrong size.</li> </ul>	<ul style="list-style-type: none"> <li>Clean and gap the spark plug. Check the Specifications section for the correct plug and gap for your unit. Restart.</li> <li>Replace the spark plug. Check the Specifications section for the correct plug and gap for your unit. Restart.</li> </ul>

# Troubleshooting Guide

## LOW POWER OUTPUT

What To Check	Possible Cause	Remedy
<p>Is the engine overheating?</p>	Operator is overworking the unit.	Use a lower throttle setting.
	Carburetor mixture is too lean.	Consult with an authorized Shindaiwa servicing dealer.
	Improper fuel ratio.	Refill with fresh, clean unleaded gasoline with a pump octane of 89 or higher mixed with an air cooled engine oil that meets or exceeds ISO-L-EGD (ISO/CD 13738) and J.A.S.O. M345-FD classified oils at 50:1 gasoline/oil ratio.
	Fan, fan cover, cylinder fins dirty or damaged.	Clean, repair or replace as necessary.
	Carbon deposits on the piston or in the muffler.	Consult with an authorized Shindaiwa servicing dealer.
<p>Engine is rough at all speeds. May also have black smoke and/or unburned fuel at the exhaust.</p>	Clogged air filter.	Service the air filter.
	Loose or damaged spark plug.	Tighten or replace the spark plug. Check the Specifications section for the correct plug and gap for your unit.
	Air leakage or clogged fuel line.	Repair or replace fuel filter and/or fuel line.
	Water in the fuel.	Refill with fresh, clean unleaded gasoline with a pump octane of 89 or higher mixed with an air cooled engine oil that meets or exceeds ISO-L-EGD (ISO/CD 13738) and J.A.S.O. M345-FD classified oils at 50:1 gasoline/oil ratio.
	Piston seizure.	Consult with an authorized Shindaiwa servicing dealer.
	Faulty carburetor and/or diaphragm.	
<p>Engine is knocking.</p>	Overheating condition.	Consult with an authorized Shindaiwa servicing dealer.
	Improper fuel.	Refill with fresh, clean unleaded gasoline with a pump octane of 89 or higher mixed with an air cooled engine oil that meets or exceeds ISO-L-EGD (ISO/CD 13738) and J.A.S.O. M345-FD classified oils at 50:1 gasoline/oil ratio.
	Carbon deposits in the combustion chamber.	Consult with an authorized Shindaiwa servicing dealer.

## Troubleshooting Guide

### ADDITIONAL PROBLEMS

Symptom	Possible Cause	Remedy
Poor acceleration.	<ul style="list-style-type: none"> <li>Clogged air filter.</li> <li>Clogged fuel filter.</li> <li>Lean fuel/air mixture.</li> <li>Idle speed set too low.</li> </ul>	<ul style="list-style-type: none"> <li>Clean the air filter.</li> <li>Replace the fuel filter.</li> <li>Consult with an authorized Shindaiwa servicing dealer.</li> <li>Adjust idle. Check Specifications page for correct idle speed.</li> </ul>
Engine stops abruptly.	<ul style="list-style-type: none"> <li>Ignition switch turned off.</li> <li>Fuel tank empty.</li> <li>Water in the fuel.</li> <li>Clogged fuel filter.</li> <li>Shorted spark plug or loose terminal.</li> <li>Ignition failure.</li> <li>Piston seizure.</li> </ul>	<ul style="list-style-type: none"> <li>Reset the switch and re-start.</li> <li>Refill with fresh, clean unleaded gasoline with a pump octane of 89 or higher mixed with an air cooled engine oil that meets or exceeds ISO-L-EGD (ISO/CD 13738) and J.A.S.O. M345- FD classified oils at 50:1 gasoline/oil ratio.</li> <li>Replace fuel filter.</li> <li>Clean or replace spark plug. Check the Specifications section for the correct plug and gap for your unit. Tighten the terminal.</li> <li>Replace the ignition unit.</li> <li>Consult with an authorized Shindaiwa servicing dealer.</li> </ul>
Engine difficult to shut off.	<ul style="list-style-type: none"> <li>Ground (stop) wire is disconnected, or switch is defective.</li> <li>Overheating due to incorrect spark plug.</li> <li>Overheated engine.</li> </ul>	<ul style="list-style-type: none"> <li>Test and replace as required.</li> <li>Replace the spark plug. Check the Specifications section for the correct plug and gap for your unit. Restart.</li> <li>Idle engine until cool.</li> </ul>
Engine will not idle down.	<ul style="list-style-type: none"> <li>Idle set too high.</li> <li>Engine has an air leak.</li> </ul>	<ul style="list-style-type: none"> <li>Adjust idle. Check Specifications page for correct idle speed.</li> <li>Consult with an authorized Shindaiwa servicing dealer.</li> </ul>
Cutting attachment moves at engine idle.	<ul style="list-style-type: none"> <li>Engine idle too high.</li> <li>Broken clutch spring or worn clutch spring boss.</li> </ul>	<ul style="list-style-type: none"> <li>Adjust idle. Check Specifications page for correct idle speed.</li> <li>Replace spring/shoes as required, check idle speed.</li> </ul>
Excessive vibration.	<ul style="list-style-type: none"> <li>Loose attachment holder.</li> <li>Warped or damaged attachment.</li> <li>Loose gearcase.</li> <li>Bent main shaft/worn or damaged bushings.</li> </ul>	<ul style="list-style-type: none"> <li>Inspect and re-tighten holders securely.</li> <li>Inspect and replace attachment as required.</li> <li>Tighten gearcase securely.</li> <li>Inspect and replace as necessary.</li> </ul>
Cutting attachment will not move.	<ul style="list-style-type: none"> <li>Shaft not installed in powerhead or gearcase.</li> <li>Broken shaft.</li> <li>Damaged gearcase.</li> </ul>	<ul style="list-style-type: none"> <li>Inspect and reinstall as required.</li> <li>Consult with an authorized Shindaiwa servicing dealer.</li> </ul>

## Specifications

<b>Model Name</b>	<b>T242</b>
Length w/o cutter head	1,740 mm (68.5 in.)
Width	320 mm (12.6 in.)
Height	335 mm (13.2 in.)
Weight (dry) w/o cutter head	5.3 kg (11.7 lb.)
Engine Type	Air cooled, two-stroke, single cylinder gasoline engine
Bore	33.0 mm (1.30 in.)
Stroke	28.0 mm (1.10 in.)
Displacement	23.9 cc (1.46 cu.in.)
Carburetor	Diaphragm w/purge pump
Air Filter	Double layer felt
Ignition System	Flywheel magneto, capacitor discharge ignition type
Spark Plug	NGK BPM-8Y; Gap 0.65 mm (0.026 in.); Torque 150-170 kgf • cm (130-150 lbf • in).
Exhaust	Spark arrestor muffler or spark arrestor muffler with catalyst
Fuel	Mixed (Gasoline and two-stroke oil)
Fuel/Oil Ratio	50 : 1 Shindaiwa One® ISO-L-EGD (ISO/CD 13738) and J.A.S.O. M345-FD, two-stroke, air-cooled engine oil.
Gasoline	Use 89 Octane unleaded. Do not use fuel containing methyl alcohol, more than 10% ethyl alcohol or 15% MTBE. Do not use alternative fuels such as E-15 or E-85.
Oil	Shindaiwa One® oil ISO-L-EGD (ISO/CD 13738) and J.A.S.O. M345-FD two-stroke, air-cooled engine oil
Fuel Tank Capacity	0.63 L (21.3 US fl. oz.)
Starter System	Automatic rewind starter
Clutch	Centrifugal type
Operating Rod	24 mm (0.96 in.) diameter, aluminum tube
Drive Shaft	6 mm (0.24 in.) diameter, solid shaft with spline (10-tooth)
Gear Case Ratio	1.4:1 Reduction
Rotating Direction	Counterclockwise; viewed from top
Cutter Head	Speed Feed® 400 LH nylon line head; Line capacity 6.0 m (20 ft.)
Handles	Front - Left-hand support handle; Rear - Right-hand throttle handle
Idle Speed	3,000 RPM
Clutch Engagement Speed	3,850 RPM
Wide Open Throttle Speed (W.O.T.)	9,400 RPM

Specifications are subject to change without notice.

## Warranty statements

### SHINDAIWA LIMITED WARRANTY STATEMENT FOR PRODUCT SOLD IN USA AND CANADA BEGINNING 01/01/2013

#### ECHO, INC'S RESPONSIBILITY

ECHO Incorporated's (ECHO, INC.) Limited Warranty, provides to the original purchaser that this Shindaiwa product is free from defects in material and workmanship. Under normal use and maintenance from date of purchase, ECHO, INC. agrees to repair or replace at its discretion, any defective product free of charge at any authorized Shindaiwa servicing dealer within listed below application time periods, limitations and exclusions. **THIS LIMITED WARRANTY IS ONLY APPLICABLE TO SHINDAIWA PRODUCTS SOLD BY AUTHORIZED SHINDAIWA DEALERS. IT IS EXTENDED TO THE ORIGINAL PURCHASER ONLY, AND IS NOT TRANSFERABLE TO SUBSEQUENT OWNERS EXCEPT FOR EMISSION RELATED PARTS.** Repair parts and accessories replaced under this warranty are warranted only for the balance of the original unit or accessory warranty period. Any damage caused by improper installation or improper maintenance is not covered by this warranty. All parts or products replaced under warranty become the property of ECHO, INC. This warranty is separate from the Emission control warranty statement supplied with your new product. Please consult the Emission Control Warranty Statement for details regarding emission related parts. For a list of Authorized Shindaiwa Dealers refer to [WWW.SHINDAIWA.COM](http://WWW.SHINDAIWA.COM) or call **1-877-986-7783**.

#### OWNER'S RESPONSIBILITY

To ensure trouble free warranty coverage it is important that you register your Shindaiwa equipment on-line at [WWW.SHINDAIWA.COM](http://WWW.SHINDAIWA.COM) or by filling out the warranty registration card supplied with your unit. Registering your product confirms your warranty coverage and provides a direct link if we find it necessary to contact you.

The owner shall demonstrate reasonable care and use, and follow preventative maintenance, storage, fuel and oil usage as prescribed in the operator's manual. Should a product difficulty occur, you must, at your expense, deliver or ship your Shindaiwa unit to an authorized Shindaiwa servicing dealer for warranty repairs (within the applicable warranty period), and arrange for pick-up or return of your unit after the repairs have been made. For your nearest authorized Shindaiwa servicing dealer, call Shindaiwa's Dealer Referral Center, at 1-877-986-7783 or you can locate a Shindaiwa servicing dealer at [WWW.SHINDAIWA.COM](http://WWW.SHINDAIWA.COM). Should you require assistance or have questions concerning Shindaiwa's Warranty Statement, you can contact our Consumer Product Support Department at 1-800-673-1558 or contact us through the web at [WWW.SHINDAIWA.COM](http://WWW.SHINDAIWA.COM).

#### PRODUCT WARRANTY PERIOD

##### RESIDENTIAL APPLICATION

- **5 YEAR WARRANTY** - Units for residential, or non-income producing use will be covered by this limited warranty for five (5) years from date of purchase.

##### EXCEPTIONS:

- For engine powered products, the electronic ignition module, flexible drive cable, and solid drive shaft are warranted for the life\* of the product on parts only.
- Cutting attachments such as, but not limited to, bars, chains, sprockets, tines, blades, PowerBroom™, belts, and nylon trimmer heads for residential or non-income producing use will be covered for failures due to defects in material or workmanship for a period of 60 days from original product purchase date. Any misuse from contact with concrete, rocks, or other structures is not covered by this warranty.
- Multipurpose Tool Attachments carry the same warranty duration as the units they are designed to fit.

##### COMMERCIAL APPLICATION

- **90 DAY WARRANTY** - All Chain Saws and Cut-Off Saws for commercial, institutional, agricultural, industrial, or income producing use will be covered by this limited warranty for 90 Days from the date of purchase.
- **2 YEAR WARRANTY** - All other units for commercial, institutional, agricultural, industrial, or income producing use will be covered by this limited warranty for two (2) years from the date of purchase.

##### EXCEPTIONS:

- For engine powered products, the electronic ignition module, flexible drive cables, and solid drive shafts are warranted for the life\* of the product on parts only.
- Cutting attachments such as, but not limited to, bars, chains, sprockets, tines, blades, PowerBroom™, belts, and nylon trimmer heads for commercial, institutional, agricultural, industrial, rental, or income producing will be covered for failures due to defects in material or workmanship for a period of 30 days from original product purchase date. Any misuse from contact with concrete, rocks, or other structures is not covered by this warranty.
- Multipurpose Tool Attachments carry the same warranty duration as the units they are designed to fit.

##### RENTAL APPLICATION - 90 DAYS WARRANTY

- Units for rental use will be covered against defects in material and workmanship for a period of 90 days from the date of purchase.

\* ECHO INC's liability under the "Lifetime" coverage is limited to furnishing parts specified under the PRODUCT Warranty PERIOD section of this warranty statement for "Life" free of charge for a period of ten (10) years after the date of the complete unit's final production.



## Warranty statements

### PURCHASED REPAIR PARTS AND ACCESSORIES

- 90-day all applications

### ATTENTION ENGINE POWERED PRODUCT OWNERS

This Shindaiwa engine powered product is a quality-engineered unit which has been manufactured to exact tolerances to provide superior performance. To help ensure the performance of the unit, it is required to use engine oil which meets the ISO-L-EGD Standard per ISO/CD 13738 and JASO M345/FD Standards. Shindaiwa Red Armor™ and Shindaiwa One™ are a premium engine oil specifically formulated to meet ISO-L-EGD (ISO/CD 13738) and JASO M345/FD Standards. The use of engine oils designed for other applications, such as for outboard motors or lawnmowers can result in severe engine damage, and will void your engine limited warranty.

### THIS WARRANTY DOES NOT COVER DAMAGE CAUSED BY:

- Lack of lubrication or engine failure, due to the use of engine oils that do not meet the ISO-L-EGD (ISO/CD 13738) and JASO M345/FD Standards. Shindaiwa Red Armor™ and Shindaiwa One™ Engine Oil meets the ISO-L-EGD and JASO M345/FD Standard. Emission related parts are covered for 5 years residential or 2 years commercial use regardless of two-stroke oil used, per the statement listed in the EPA or California Emission Control Warranty Explanation.
- Damage caused by use of gasohol, containing methanol (wood alcohol), or gasoline containing less than 89 octane. Only use gasoline which contains 89 octane or higher. Gasohol which contains a maximum 10% ethanol (grain alcohol) or 15% MTBE (methyl/tertiary/butyl/ether) is also approved. The prescribed mixing ratio of gasoline to oil is listed on the Shindaiwa oil label and covered in your operator's manual.
- Engine damage caused by use of ether or any starting fluids.
- Damage caused by tampering with engine speed governor or emission components, or running engines above specified and recommended engine speeds as listed in your operator's manual.
- Operation of the unit with improperly maintained/removed cutting shield or removed/damaged air filter.
- Damage caused by dirt, pressure or steam cleaning the unit, salt water, corrosion, rust, varnish, abrasives, and moisture.
- Defects, malfunctions or failures resulting from abuse, misuse, neglect, modifications, alterations, normal wear, improper servicing, or use of unauthorized attachments.
- Incorrect storage procedures, stale fuel, including failure to provide or perform required maintenance services as prescribed in the operator's manual. Preventative maintenance as outlined in the operator's manual is the customer's responsibility.
- Failures due to improper set-up, pre-delivery service or repair service by anyone other than authorized Shindaiwa servicing dealer during the warranty period.
- Certain parts and other items are not warranted, including but not limited to: lubricants, starter cords, and engine tune-ups.
- Use of spark plugs other than those meeting performance and durability requirements of the OEM spark plug listed in the Operator's Manuals.
- Overheating or carbon scoring failures due to restricted, clogged exhaust port or combustion chamber, including damage to spark arrester screen.
- Adjustments after the first (30) thirty days and beyond, such as carburetor adjustment and throttle cable adjustment.
- Damage to gears or gear cases caused by contaminated grease or oil, use of incorrect type or viscosity of lubricants, and/or failure to comply with recommended grease or oil change intervals.
- Damage caused by pump or sprayer running dry, pumping or spraying caustic or flammable materials, or lack of or broken strainers.
- Additional damage to parts or components due to continued use after operational problem or failure occurs. Should operational problem or failure occur, the product should not be used, but delivered as is to an authorized Shindaiwa servicing dealer.

It is a dealer's and/or customer's responsibility to complete and return the warranty registration card supplied with your Shindaiwa product or by visiting [WWW.SHINDAIWA.COM](http://WWW.SHINDAIWA.COM). Your receipt of purchase including date, model and serial number must be maintained and presented to an authorized Shindaiwa servicing dealer for warranty service. Proof of purchase rests solely with the customer. Some states do not allow limitations on how long an implied warranty lasts, so the above limitations may not apply to you. Some states do not allow the exclusion or limitation of incidental or consequential damages, so you may also have other specific legal rights which vary from state to state. This limited warranty is given by ECHO Incorporated, 400 Oakwood Rd., Lake Zurich, IL 60047.

### DISCLAIMER OF IMPLIED WARRANTIES

This limited warranty is in lieu of all other expressed or implied warranties, including any warranty of FITNESS FOR A PARTICULAR PURPOSE OR USE and any implied warranty of **MERCHANTABILITY** otherwise applicable to this product. ECHO, INC. and its affiliated companies shall not be liable for any special incidental or consequential damage, including lost profits. There are no warranties extended other than as provided herein. This limited warranty may be modified only by ECHO, INC.



## Servicing Information

---

### Parts/Serial Number

Genuine Shindaiwa Parts and Assemblies for your Shindaiwa products are available only from an Authorized Shindaiwa Dealer. When you do need to buy parts **always** have the Model Number, Type and Serial Number of the unit with you. You can find these numbers on the engine. For future reference, write them in the space provided below.

Model No. \_\_\_\_\_ SN. \_\_\_\_\_

### Service

Service of this product during the warranty period must be performed by an Authorized Shindaiwa Service Dealer. For the name and address of the Authorized Shindaiwa Service Dealer nearest you, ask your retailer or call: 1-877-986-7783. Dealer information is also available on WWW.SHINDAIWA.COM. When presenting your unit for Warranty service/repairs, proof of purchase is required.

### Consumer Product Support

If you require assistance or have questions concerning the application, operation or maintenance of this product you may call the Shindaiwa Consumer Product Support Department at 1-877-986-7783 from 8:30 am to 4:30 pm (Central Standard Time) Monday through Friday. Before calling, please know the model and serial number of your unit.

### Warranty Registration

To ensure trouble free warranty coverage it is important that you register your Shindaiwa equipment by filling out the warranty registration card supplied with your unit or online at [www.shindaiwa.com](http://www.shindaiwa.com). Registering your product confirms your warranty coverage and provides a direct link if we find it necessary to contact you.

### Additional or Replacement Manuals

**Replacement Operator and Parts Catalogs** are available from your Shindaiwa dealer or at [WWW.SHINDAIWA.COM](http://WWW.SHINDAIWA.COM) or by contacting the Consumer Product Support Department (1-877-986-7783). Always check [WWW.SHINDAIWA.COM](http://WWW.SHINDAIWA.COM) for updated information.

# shindaiwa®

ECHO Incorporated.  
400 Oakwood Road  
Lake Zurich, IL 60047-1564 U.S.A.  
Telephone: 1-877-986-7783  
Fax: 1-847-540-8416  
[www.shindaiwa.com](http://www.shindaiwa.com)

Copyright© 2014 By ECHO Incorporated  
All Rights Reserved.

Yamabiko Corporation  
7-2 Suehirocho 1-Chome, Ohme,  
Tokyo, 198-8760, Japan  
Phone: 81-428-32-6118  
Fax: 81-428-32-6145

T16311005861-T16311999999  
T16212038844-T16212999999