

English.....1  
Français.....FR\_1  
Italiano.....IT\_1

SHINDAIWA OWNER'S/OPERATOR'S MANUAL

# T242XS GRASS TRIMMER C242S BRUSHCUTTER

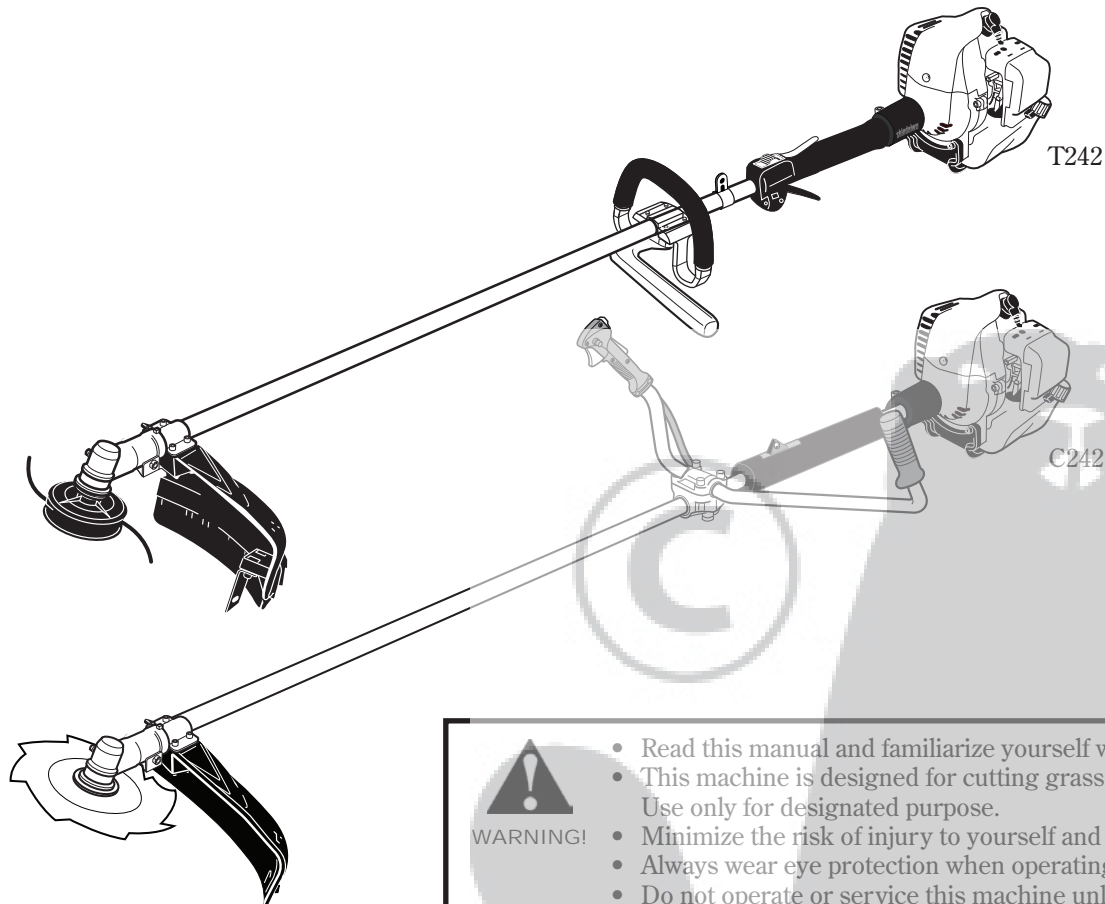

WARNING!

- Read this manual and familiarize yourself with its contents.
- This machine is designed for cutting grass, weeds and brush. Use only for designated purpose.
- Minimize the risk of injury to yourself and others.
- Always wear eye protection when operating this machine.
- Do not operate or service this machine unless you clearly understand this manual.
- Keep this manual available at all times so that you can reference it whenever you have a question about the use of this unit.

# shindaiwa

Part Number 62121-94310 Rev. 3/07

## Introduction

The Shindaiwa 242 Series hand held power equipment has been designed and built to deliver superior performance and reliability without compromise to quality, comfort, safety or durability.

Shindaiwa engines represent the leading edge of high-performance engine technology, delivering exceptionally high power with remarkably low displacement and weight. As an owner/operator, you'll soon discover for yourself why Shindaiwa is simply in a class by itself!

### IMPORTANT!

The information contained in this owner's/operator's manual describes units available at the time of publication.

Shindaiwa Inc. reserves the right to make changes to products without prior notice, and without obligation to make alterations to units previously manufactured.

## Contents

	PAGE
Attention Statements .....	2
Safety Information.....	2
Safety Labels.....	4
Product Description.....	5
Specifications.....	5
Assembly and Adjustments.....	6
Mixing Fuel .....	11
Starting the Engine.....	11
Stopping the Engine .....	12
Adjusting Engine Idle .....	12
Checking Unit Condition.....	12
Shoulder Strap.....	13
Cutting Grass with a Trimmer Head .....	13
Using a Blade.....	14
Maintenance .....	15
Long Term Storage.....	18
Blade Sharpening.....	18
Troubleshooting Guide .....	19
Declaration of Conformity.....	21

## Attention Statements

Throughout this manual are special "Attention Statements".



### WARNING!

A statement preceded by the triangular attention symbol and the word "WARNING" contains information that should be acted upon to prevent serious bodily injury.

### CAUTION!

A statement preceded by the word "CAUTION" contains information that should be acted upon to prevent mechanical damage.

### IMPORTANT!

A statement preceded by the word "IMPORTANT" is one that possesses special significance.

### NOTE:

A statement preceded by the word "NOTE" contains information that is handy to know and may make your job easier.



Read and follow this operator's manual. Failure to do so could result in serious injury.



Wear eye and hearing protection at all times during operation of this unit.



Wear non-slip gloves, long trousers and non-skid boots during the operation of this machine.

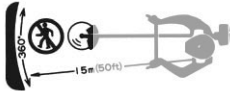

Make sure no one is within 15 meters of an operating machine.



Beware of thrown objects.



The maximum speed of the cutting attachment shaft in  $\text{min}^{-1}$ .



Sound Power Level (measured in accordance with 2000/14/EC).

### IMPORTANT!

The operational procedures described in this manual are intended to help you get the most from this unit as well as to protect you and others from harm. These procedures are guidelines for safe operation under most conditions, and are not intended to replace any safety rules and/or laws that may be in force in your area. If you have questions regarding your 242 series hand held power equipment, or if you do not understand something in this manual, your Shindaiwa dealer will be glad to assist you. You may also contact Shindaiwa Inc. at the address printed on the back of this Manual.

## General Safety Instructions

### Work Safely

Shindaiwa trimmers operate at very high speeds and can do serious damage or injury if they are misused or abused. Never allow a person without training or instruction to operate this unit!



### WARNING!

Never make unauthorized attachment installations. Do not use attachments not approved by Shindaiwa for use on this unit.

### Stay Alert

You must be physically and mentally fit to operate this unit safely.



### WARNING!



Never operate power equipment of any kind if you are tired or if you are under the influence of alcohol, drugs, medication or any other substance that could affect your ability or judgement.



### WARNING!

- Never operate a trimmer with damaged or missing anti-vibration cushions. Long-term exposure to vibration can damage your hands, in particular vascular, bone or joint, neurological or muscular disorders. For lowest vibration, replace damaged mounts immediately. Mounts hardened due to age or weathering should also be replaced.
- Prolonged exposure to excessive noise is fatiguing and could lead to impaired hearing. The use of proper ear protection can reduce this potential hazard.



### WARNING!

The engine exhaust from this product contains chemicals which may cause cancer, birth defects or other reproductive harm.

## General Safety Instructions



### WARNING!

#### Use Good Judgment

**ALWAYS** wear eye protection to shield against thrown objects.

**NEVER** run the engine when transporting the unit.

**NEVER** run the engine indoors! Make sure there is always good ventilation. Fumes from engine exhaust can cause serious injury or death.

**ALWAYS** clear your work area of trash or hidden debris that could be thrown back at you or toward a bystander.

**ALWAYS** use the proper cutting tool for the job.

**ALWAYS** stop the engine immediately if it suddenly begins to vibrate or shake. Inspect for broken, missing or improperly installed parts or attachments.

**NEVER** extend trimming line beyond the length specified for your unit.

**ALWAYS** keep the unit as clean as practical. Keep it free of loose vegetation, mud, etc.

**ALWAYS** hold the unit firmly with both hands when cutting or trimming, and maintain control at all times.

**ALWAYS** keep the handles clean.

**ALWAYS** disconnect the spark plug wire before performing any maintenance work.

**ALWAYS**, if a saw blade should bind fast in a cut, shut off the engine immediately. Push the branch or tree to ease the bind and free the blade.

## The Properly Equipped Operator

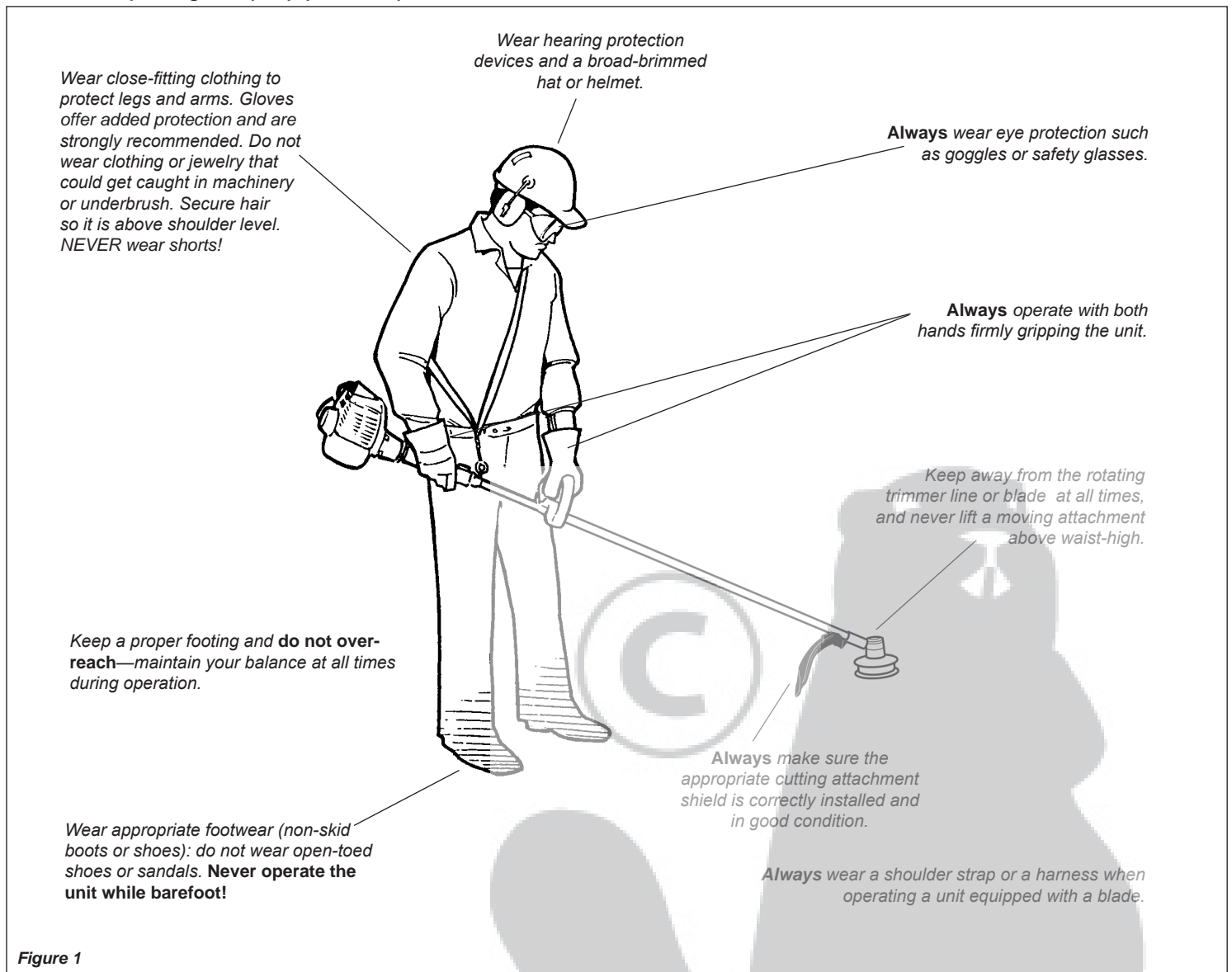

Figure 1

## Be Aware of the Working Environment

*Avoid long-term operation in very hot or very cold weather.*

*Make sure bystanders or observers outside the 15 meters "danger zone" wear eye protection.*

*Reduce the risk of bystanders being struck by flying debris. Make sure no one is within 15 meters—that's about 16 paces—of an operating attachment.*

*When operating in rocky terrain or near electric wires or fences, use extreme caution to avoid contacting such items with the cutting attachment.*

*Always make sure the appropriate cutting attachment shield is correctly installed.*

*Be extremely careful of slippery terrain, especially during rainy weather.*

*If contact is made with a hard object, stop the engine and inspect the cutting attachment for damage.*

*Be constantly alert for objects and debris that could be thrown either from the rotating cutting attachment or bounced from a hard surface.*

*Beware of a coasting blade when brushcutting. A coasting blade can injure while it continues to spin after the throttle trigger is released or after the engine is stopped.*

Figure 2

## Safety Labels

**Attach handle on this line.**

T242

C242

**IMPORTANT!**

**Safety and Operation Information Labels:** Make sure all information labels are undamaged and readable. Immediately replace damaged or missing information labels. New labels are available from your local authorized Shindaiwa dealer.

Figure 3

# Product Description

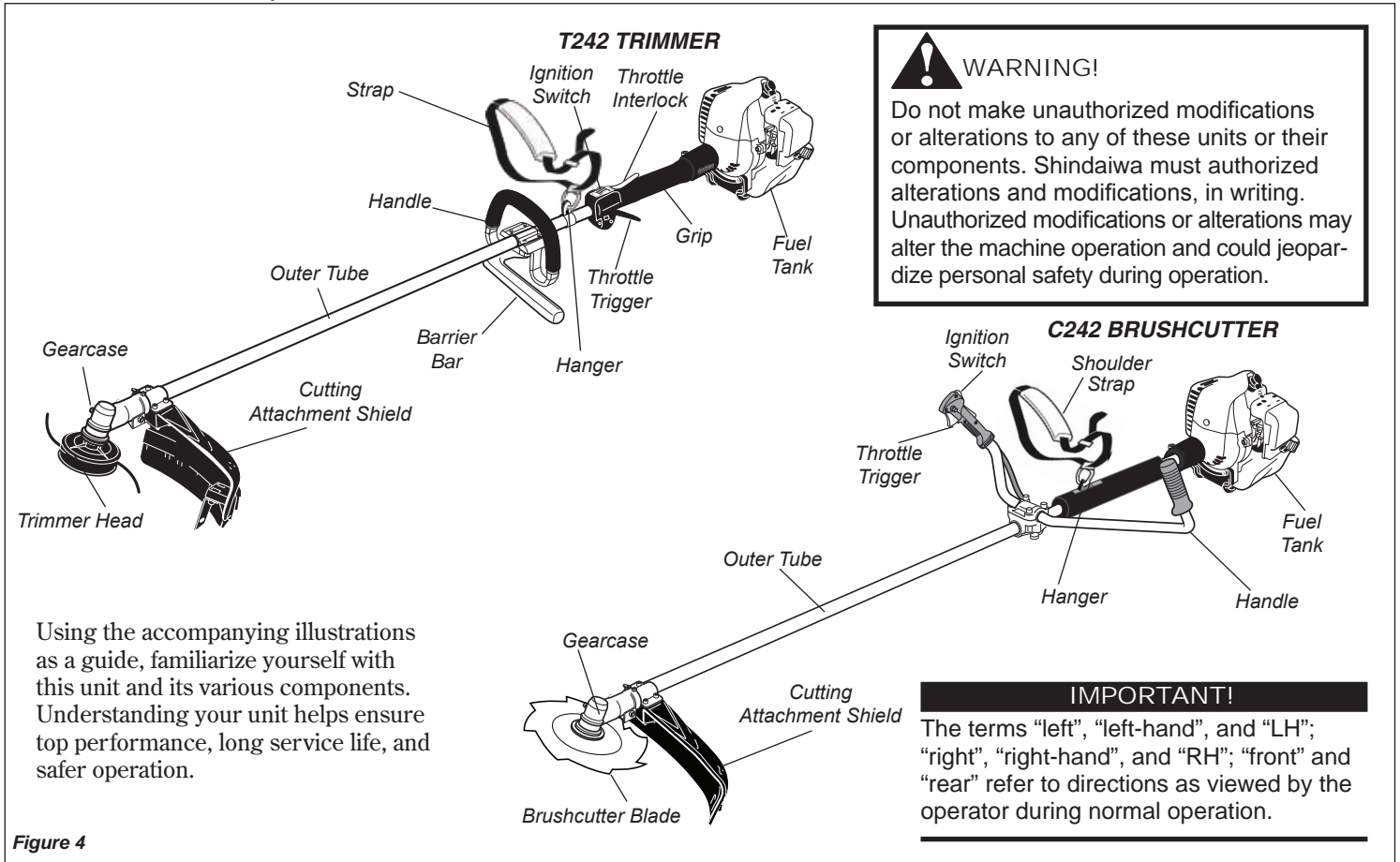

Figure 4

Using the accompanying illustrations as a guide, familiarize yourself with this unit and its various components. Understanding your unit helps ensure top performance, long service life, and safer operation.

## Specifications

	T242XS/EC2	C242S/EC2
Engine Name	242 EC2	
Engine Model	242 EC2	
Engine Type	2-cycle, vertical-cylinder, air-cooled	
Displacement	23.9 cm <sup>3</sup>	
Bore X Stroke	33 x 28 mm	
Maximum Speed (at the cutting attachment shaft)	8,900 min <sup>-1</sup>	
Engine Speed at Idling	2,750 min <sup>-1</sup>	
Maximum Engine Speed	12,000 min <sup>-1</sup>	
Maximum Engine Speed at Maximum Power Output	8,000 min <sup>-1</sup>	
Maximum Power Output	0.8 kW	
Ignition	CDI	
Spark Plug	NGK BPMR6A	
Starting Method	Recoil Starter	
Stopping Method	Slide Switch	
Air Cleaner Type	Foam filter element	
Fuel/Oil Ratio	50:1	
Fuel Tank Capacity	620 cm <sup>3</sup>	
Carburetor Type	Walbro WYK-Diaphragm	
Dry Weight (without cutting attachment and guard)	5.1 kg	5.1 kg
Dimensions (L X W X H)	1730 X 375 X 325 mm	1730 X 580 X 485 mm
Sound Pressure Level*	TRIMMER	97 dB(A)
	BLADE Note:1	94 dB(A)
Sound Power Level**	TRIMMER	106 dB(A)
	BLADE Note:1	102 dB(A)
Vibration Level***	Idling [Front (Left)/Rear (Right)]	TRIMMER [4.7/1.5] m/s <sup>2</sup>
		BLADE Note:1 [4.7/1.9] m/s <sup>2</sup>
	WOT [Front (Left)/Rear (Right)]	TRIMMER [4.7/6.0] m/s <sup>2</sup>
		BLADE Note:1 [3.9/5.7] m/s <sup>2</sup>
Handle Type	Loop Type Handle	Bicycle Type Handle

Specifications are subject to change without notice.

\* Sound Pressure Level: In accordance with EN ISO 11806 and ISO 22868 (average data between at Idling and at WOT).

\*\* Sound Power Level: In accordance with EN ISO 11806 and ISO 22868 (average data between at Idling and at WOT).

\*\*\* Vibration Level: In accordance with EN ISO 11806 and ISO 22867.

Note:1: 8-tooth blade equipped.

## Prior to Assembly

Before assembling, make sure you have all the components required for a complete unit. This machine consists of the following components and accessories. Carefully inspect all components for damage. If you find any damage or missing items, ask your Shindaiwa dealer for consultation.

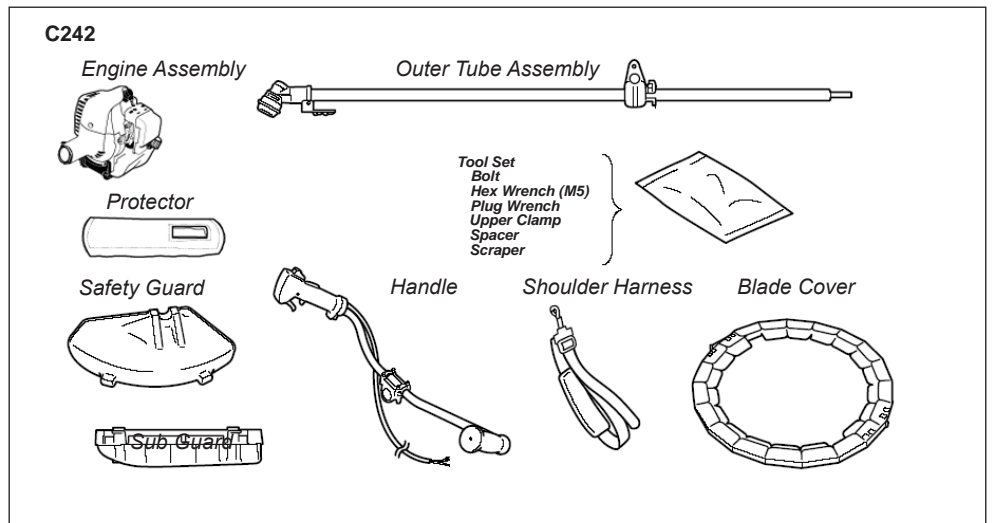
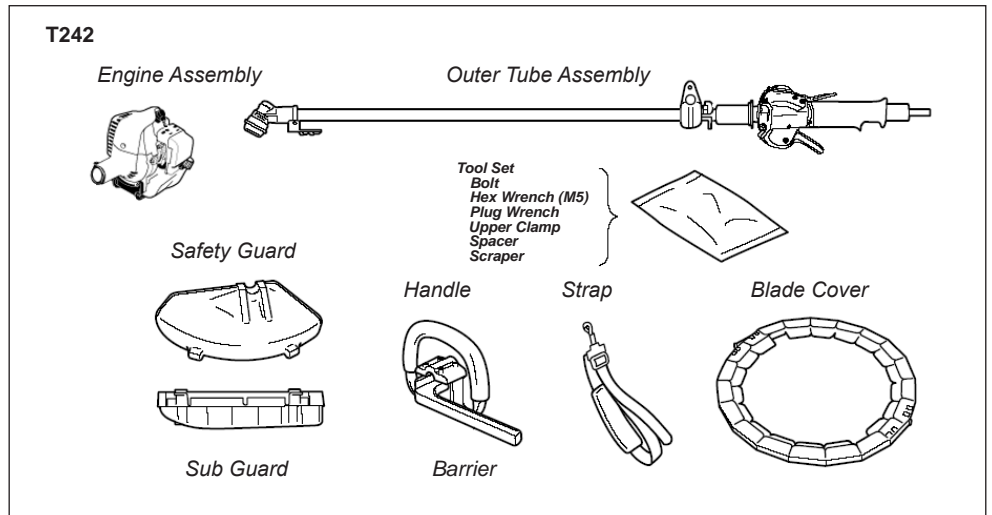

## Assembly and Adjustments

### Assembly of the Outer Pipe

1. Using the hex wrench, loosen the joint bolt.
2. Slip the outer pipe into the joint until the pipe bottoms. The outer pipe or gearcase shaft may have to be rotated slightly for the splines on the mainshaft to fully engage to the engine.

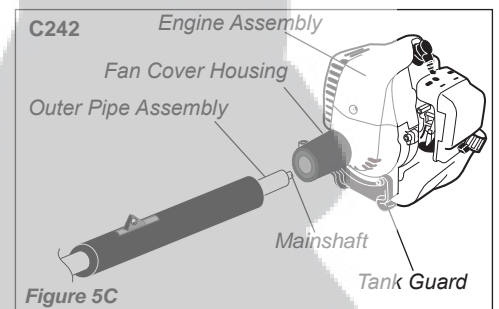
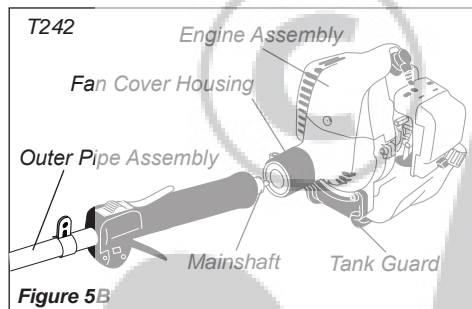
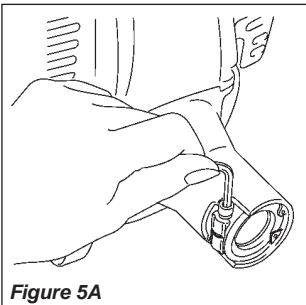

3. Tighten the joint bolt securely using the hex wrench.

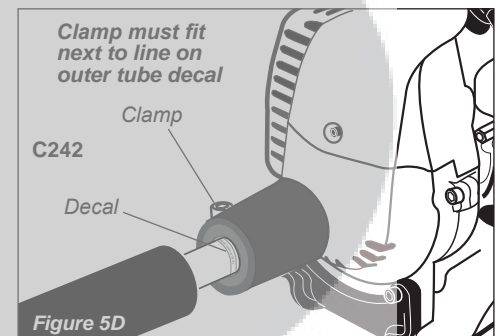

# Assembly and Adjustments

## Handle

### Handle T242

1. Put the 4 square nuts into the frame of the barrier. See figure 6.
2. Fit the handle and barrier over the outer pipe and tighten the 4 bolts.
3. Position the handle about 250 mm ahead of the throttle housing end.
4. Secure the handle by alternately tightening the four bolts in a diagonal or "crisscross" fashion.

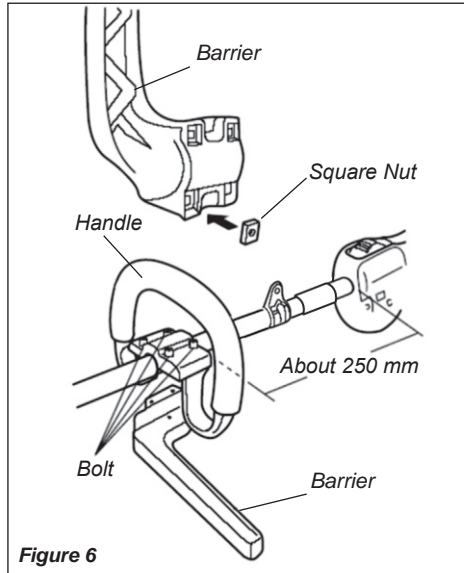

### Handle Bar C242

1. Use the 4 mm hex wrench to remove the lower cap retaining screws from the handlebar bracket. Remove the cap from the bracket. See Figure 7.
2. Position the handle on the outer tube forward of Handle Positioning Label as shown in Figure 7. Reassemble the lower cap to the handlebar bracket in the reverse order of disassembly.
3. Locate the handle in the best position for operator comfort.
4. Firmly tighten both lower cap retaining screws.
5. Install the protector sleeve on the outer tube. See Figure 7.

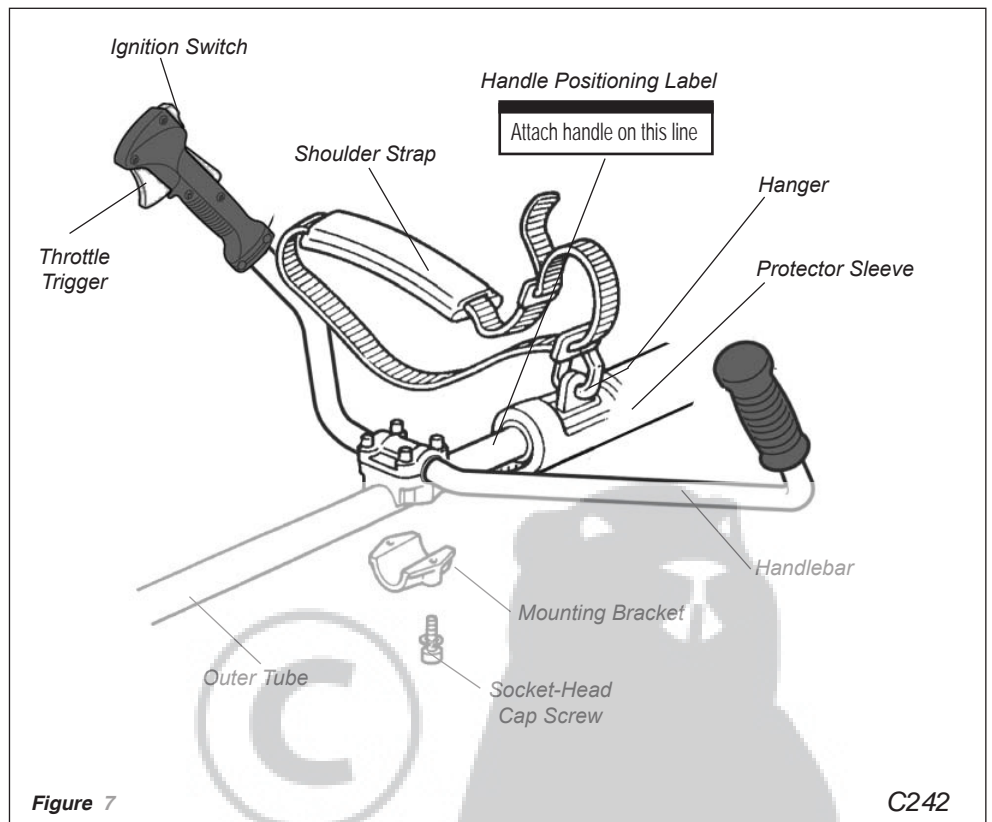

# Assembly and Adjustments

## Hook Up Throttle Cable

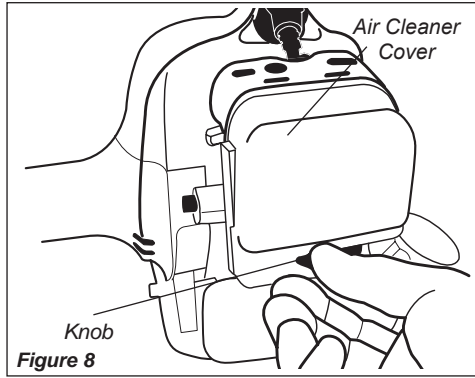

1. Loosen the air cleaner cover knob and remove the air cleaner cover. See Figure 8.

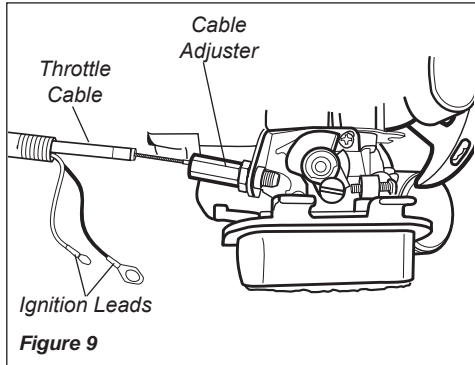

2. Loop the ribbed cable tube under the tube and to the top left side of the engine and push cable through the cable adjuster. See Figure 9.

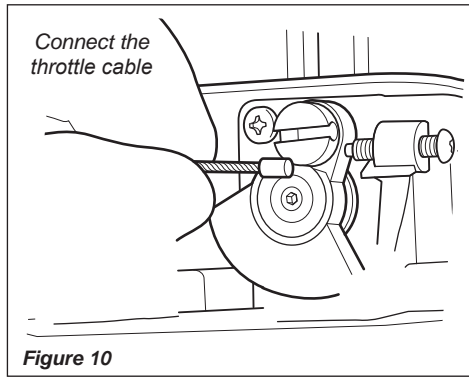

3. Connect the bullet shaped end of the throttle cable to the throttle lever on top of the carburetor. See Figure 10.

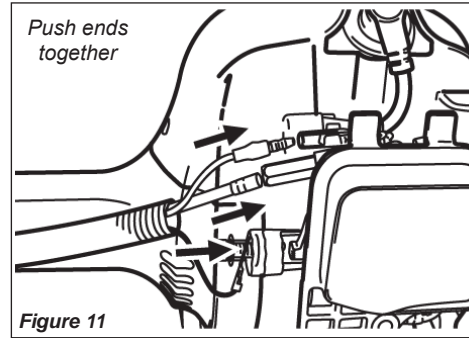

4. Connect ignition leads. See Figure 11.

### CAUTION!

Wiring runs must not interfere with throttle operation.

# Assembly and Adjustments

## Adjust Throttle Lever Free Play

The throttle lever free play should be approximately 4-6 mm. See Figure 10. Make sure that the throttle lever operates smoothly without binding. If it becomes necessary to adjust the lever free play, follow the procedures and illustrations that follow.

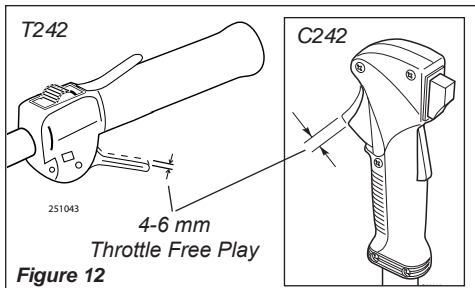

1. Loosen the lock nut on the cable adjuster. See Figure 12.
2. Turn the cable adjuster in or out as required to obtain proper free play 4-6 mm. See Figure 12.
3. Tighten the locknut.
4. Reinstall the air cleaner cover.

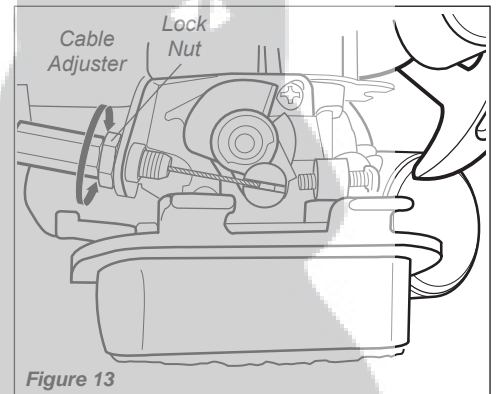



# Assembly and Adjustments

## Cutting Attachment Shield

Install the Cutting Attachment Shield T242/C242.

1. Insert the cutting attachment shield between the outer tube and the cutting attachment shield mounting plate. See Figure 14.

**NOTE:**

It may be necessary to loosen the retaining nut and clamp screw to adjust cutting attachment shield mounting plate.

2. Fit the two spacers and the bracket over the outer tube and loosely install the four socket-head cap screws. See Figure 14.
3. Tighten the four socket-head cap screws to secure the cutting attachment shield.

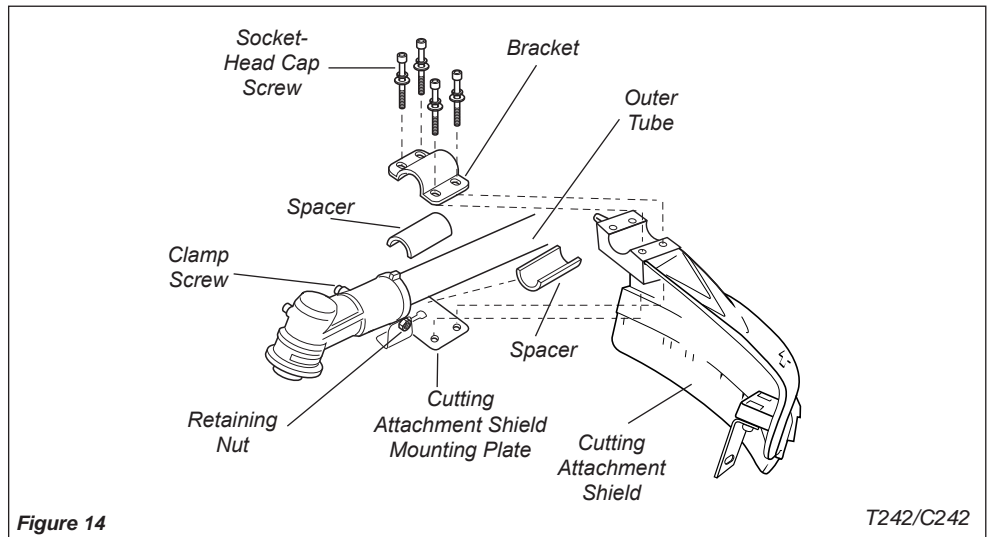

Figure 14

T242/C242

### Sub-Shield.

(when trimmer head is in use)

1. Attach the shield extension to the cutting attachment shield. See Figure 15.

**WARNING!**  
NEVER use this machine without sub-shield when using a trimmer head.

**CAUTION!**  
Make sure the sub-guard is completely hooked at the hook receiver.

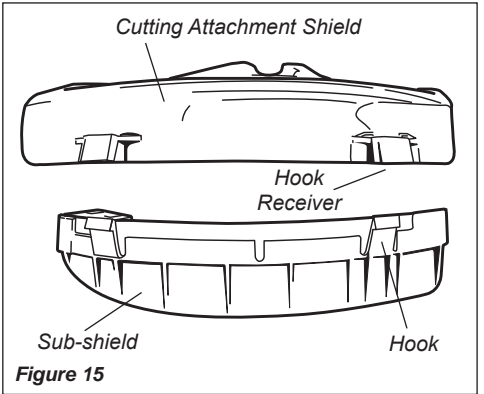

Figure 15

**CAUTION!**  
Make sure the clamp screw and retaining nut are securely tightened before tightening the four socket-head cap screws.

**WARNING!**  
NEVER operate the unit without the cutting attachment shield installed and tightly secured!

## Assembly

### Installing a Trimmer Head

**NOTE:**

The 242 is shipped with Holder A, Holder B, shaft bolt, and bolt guard installed. The shaft bolt is a LEFT-HAND thread. Remove it by turning **CLOCKWISE!**

1. With the gearcase output shaft facing up, rotate the gearshaft and Holder A until the hole in Holder A aligns with the matching hole in the gearcase flange, and then lock the holder to the gearcase by inserting the long end of the hex wrench through both holes. See Figure 16.
2. Using the combination spark plug/screwdriver wrench, remove the shaft bolt, bolt guard and Holder B. (The bolt guard and shaft bolt are not used with a trimmer head). See Figure 16.
3. Install Holder B on the gearcase shaft. The splined hole on Holder B must engage with the gearcase shaft.
4. Using the hex wrench to secure Holder A, install and hand-tighten the trimmer

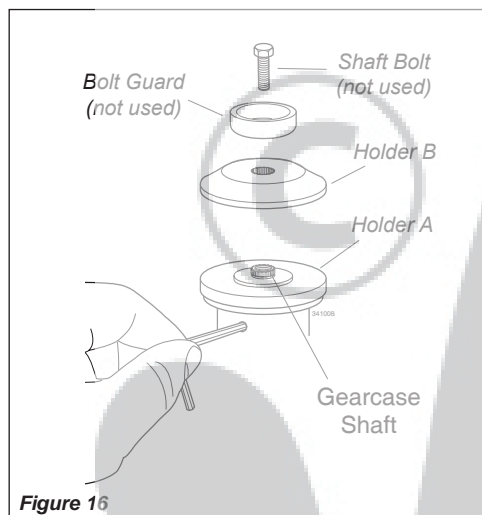

Figure 16

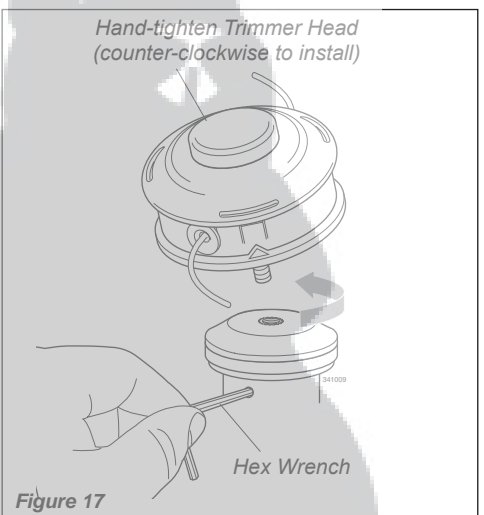

Figure 17

head (counter-clockwise to install). See Figure 17.

5. Remove the hex wrench from the gearcase and holder.

The T242/C242 should now be completely assembled to operate as a trimmer.

# Assembly

## Blade T242/C242

Mount the Saw Blade.

Turn the T242/C242 upside down so the gearcase output shaft is facing UP and remove the shaft bolt, bolt guard and Holder B from the gearcase shaft.

1. Align the hole in blade Holder A with the matching hole in the gearcase flange and then temporarily lock the output shaft by inserting a hex wrench through both holes. See Figure 18.

### CAUTION!

Install the blade so its printed surface is visible to the operator when the brushcutter is in the normal operating position.

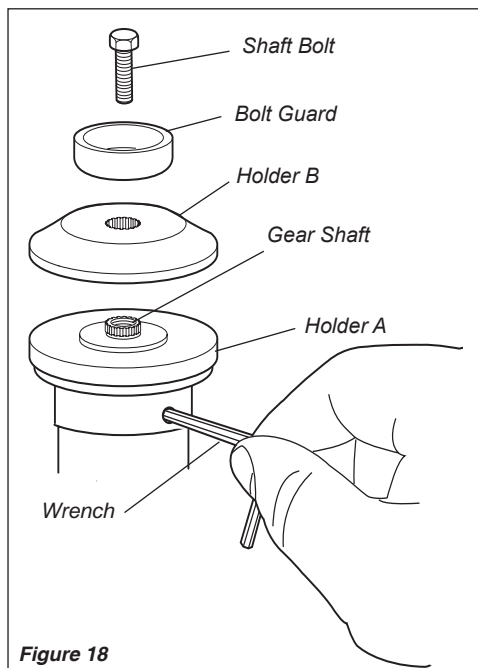
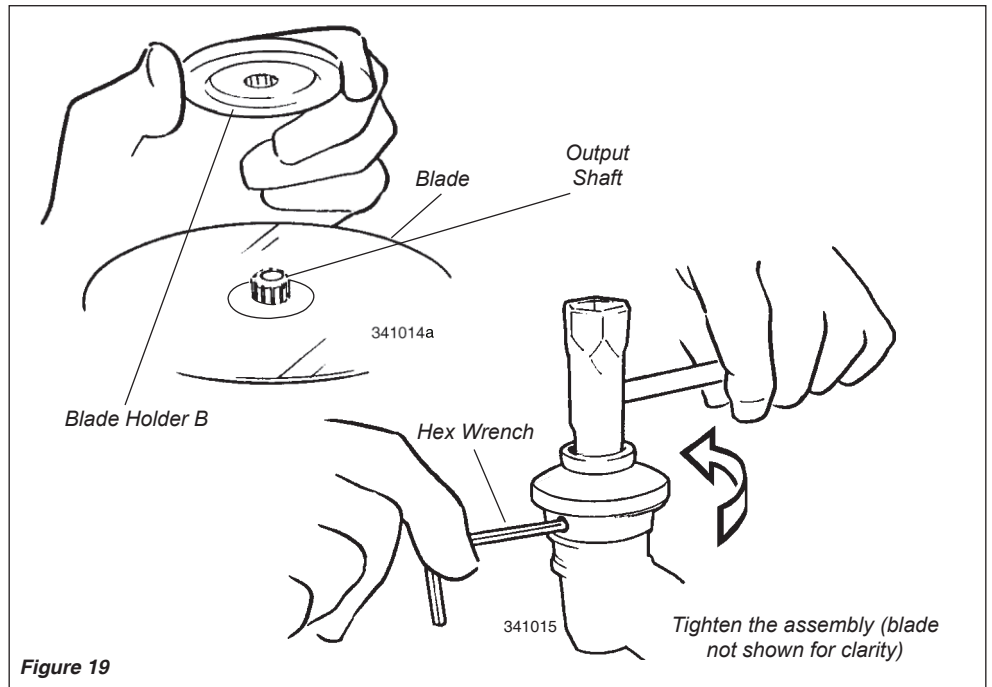

Figure 19

**WARNING!**  
The blade must fit flat against the holder flange. The blade mounting hole must be centered over the raised boss on blade Holder A.

2. Install blade Holder B on the output shaft. See Figure 19. The recess in the holder must fit tightly against the blade.



3. Install the bolt guard and then the blade retaining bolt. Using the combination spark plug wrench/screwdriver, tighten the bolt firmly in a counter-clockwise direction.
4. Remove the hex wrench.

The T242/C242 should now be completely assembled and ready for use with a blade.

## Mixing Fuel

### CAUTION!

- Some types of gasoline contain alcohol as an oxygenate. Oxygenated gasoline may cause increased operating temperatures. Under certain conditions, alcohol-based gasoline may also reduce the lubricating qualities of some 2-cycle mixing oils.
- Never use any type of gasoline containing more than 10% alcohol by volume! Generic oils and some outboard oils may not be intended for use in high-performance 2 cycle engines, and should never be used in your Shindaiwa engine.

### CAUTION!

This engine is designed to operate on a 50:1 mixture consisting of unleaded gasoline and ISO-L-EGD or JASO FC class 2-cycle mixing oil only. Use of non-approved mixing oils can lead to excessive carbon deposits.

- Use only fresh, clean unleaded gasoline with a pump octane of 87 or higher.
- Mix all fuel with a 2-cycle air-cooled mixing oil that meets or exceeds ISO-L-EGD and/or JASO FC classified oils at 50:1 gasoline/oil ratio.

Examples of 50:1 mixing quantities

Gasoline liters	2-cycle mixing oil milliliters
2.5 l.....	50 ml
5 l.....	100 ml
10 l.....	200 ml
20 l.....	400 ml

### IMPORTANT!

Mix only enough fuel for your immediate needs! If fuel must be stored longer than 30 days and **ONE** oil with fuel stabilizer is not used, it should first be treated with a fuel stabilizer such as STA-BIL™.

**shindaiwa ONE** Oil is a registered JASO FC classified oil and also meets or exceeds ISO-L-EGD performance requirements. Shindaiwa One is recommended for use in all Shindaiwa low emissions engines and also includes a fuel stabilizer.

## Filling the Fuel Tank



### WARNING!

#### Minimize the Risk of Fire

- NEVER** smoke or light fires near the engine.
- ALWAYS** stop the engine and allow it to cool before refueling.
- ALWAYS** Wipe all spilled fuel and move at least 3 meters from the fueling point and source before starting.
- ALWAYS** inspect the unit for fuel leaks before each use. During each refill, check that no fuel leaks from around the fuel cap and/or

fuel tank. If fuel leaks are evident, stop using the unit immediately. Fuel leaks must be repaired before using the unit.

**ALWAYS** move the unit at least 3 meters away from a fuel storage area or other readily flammable materials before starting the engine.

**NEVER** place flammable material close to the engine muffler.

**NEVER** operate the engine without the muffler and spark arrester screen in place.

1. Place the trimmer on a flat, level surface.
2. Clear any dirt or other debris from around the fuel filler cap.
3. Remove the fuel cap, and fill the tank with clean, fresh fuel.
4. Reinstall the fuel filler cap and tighten firmly.

## Starting the Engine

### IMPORTANT!

Engine ignition is controlled by a two position switch mounted on the throttle housing labeled, "I" for ON or START and "O" for OFF or STOP.

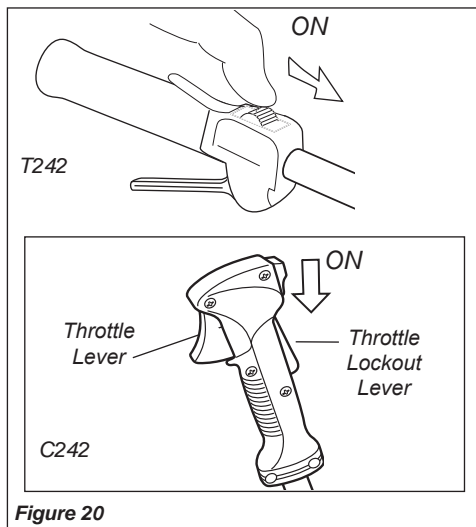

1. Slide the ignition switch to the "ON" position. See Figure 20.

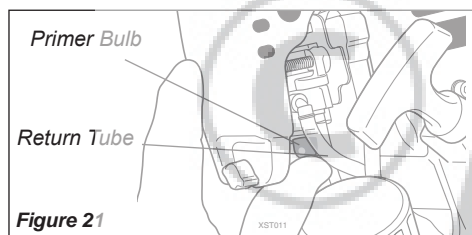

2. Press the primer bulb until fuel can be seen flowing in the transparent return tube.

### IMPORTANT!

The primer system only pushes fuel through the carburetor. Repeatedly pressing the primer bulb will not flood the engine with fuel.

3. Set the choke lever to the CLOSED position if engine is cold.

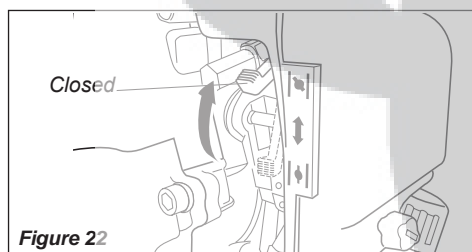

4. While holding the outer tube firmly with left hand. Use your other hand to slowly pull the recoil starter handle until resistance is felt, then pull quickly to start the engine.

### CAUTION!

Do not pull the recoil starter to the end of the rope travel. Pulling the recoil starter to the end of the rope travel can damage the starter.

## Starting the Engine (continued)



**WARNING!**  
The cutting attachment may rotate when the engine is started!

- When the engine starts, slowly move the choke lever to the "OPEN" position. See Figure 24. (If the engine stops after the initial start, close the choke and restart.)

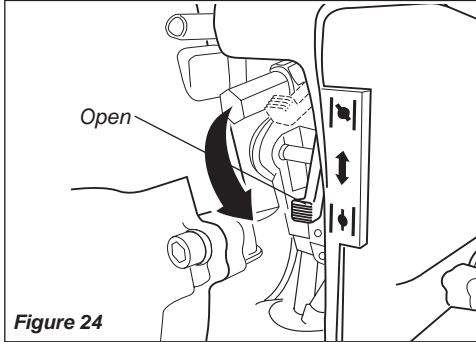

Figure 24



**WARNING!**  
Never start the engine from the operating position.

### IMPORTANT!

If the engine fails to start after several attempts with the choke in the closed position, the engine may be flooded with fuel. If flooding is suspected, move the choke lever to the open position and repeatedly pull the recoil starter to remove excess fuel and start the engine. If the engine still fails to start, refer to the troubleshooting section of this manual.

### When the Engine Starts...

- After the engine starts, allow the engine to warm up at idle 2 or 3 minutes before operating the unit.
- After the engine is warm, pick up the unit and clip on the shoulder harness or strap. See page 13.
- Advancing the throttle makes the cutting attachment turn faster; releasing the throttle permits the attachment to stop turning. If the cutting attachment continues to rotate when the engine returns to idle, carburetor idle speed should be adjusted (see "Adjusting Engine Idle" below).

## Stopping the Engine

Idle the engine briefly before stopping (about 2 minutes), then slide the ignition switch to the "O" (Engine OFF) position.

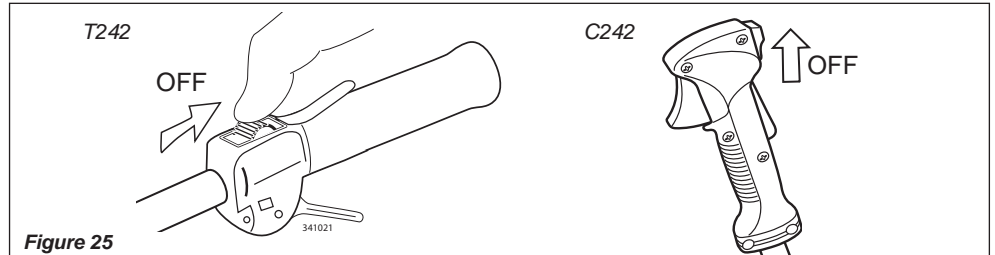

Figure 25

## Adjusting Engine Idle

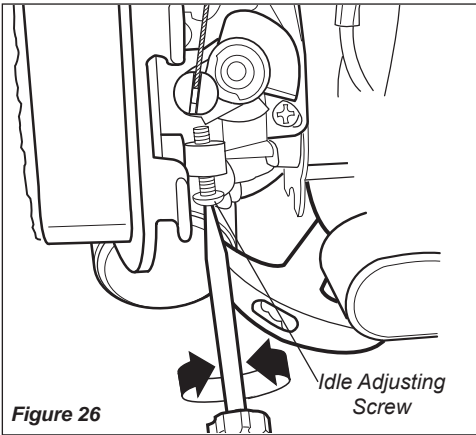

Figure 26

The engine must return to idle speed whenever the throttle lever is released. Idle speed is adjustable, and must be set low enough to permit the engine clutch to disengage the cutting attachment.

### Idle Speed Adjustment



**WARNING!**  
The cutting attachment must NEVER rotate at engine idle! If the idle speed cannot be adjusted by the procedure described here, return the trimmer to your Shindaiwa dealer for inspection.

- Place the trimmer on the ground, then start the engine, and then allow it to idle 2-3 minutes until warm.
- If the attachment rotates when the engine is at idle, reduce the idle speed by turning the idle adjustment screw counter-clockwise. See Figure 26.
- If a tachometer is available, the engine idle speed should be final adjusted to  $2,750(\pm 250)$  rpm min<sup>-1</sup>.
- Carburetor fuel mixture adjustments are preset at factory and cannot be serviced in the field.

## Checking Unit Condition

**NEVER** operate the unit with the cutting attachment shield or other protective devices removed!



**WARNING!**  
A cutting attachment shield or other protective device is no guarantee of protection against ricochet. YOU MUST ALWAYS GUARD AGAINST FLYING DEBRIS!

Use only authorized Shindaiwa parts and accessories with your Shindaiwa trimmer. Do not make modifications to this unit without written approval from Shindaiwa, Inc.

**ALWAYS** make sure the cutting attachment is properly installed and firmly tightened before operation.

**NEVER** use a cracked or warped cutting attachment: replace it with a serviceable one.

**ALWAYS** make sure the cutting attachment fits properly into the appropriate attachment holder. If a properly installed attachment vibrates, replace the attachment with new one and re-check.

**ALWAYS** stop the engine immediately and check for damage if you strike a foreign object or if the unit becomes tangled.

Do not operate with broken or damaged equipment.

**NEVER** allow the engine to run at high speeds without a load. Doing so could damage the engine.

**NEVER** operate a unit with worn or damaged fasteners or attachment holders.

When transporting, make sure the engine is not running and the blade is covered with the blade cover.

# Attaching The Shoulder Strap

## To Wear the Shoulder Strap

1. Hook the strap hook to the hanger on the outer tube.
2. Wear the shoulder strap so that the hook stays at your right hand side.
3. Adjust the length of the shoulder strap so that you can hold and operate the machine comfortably.

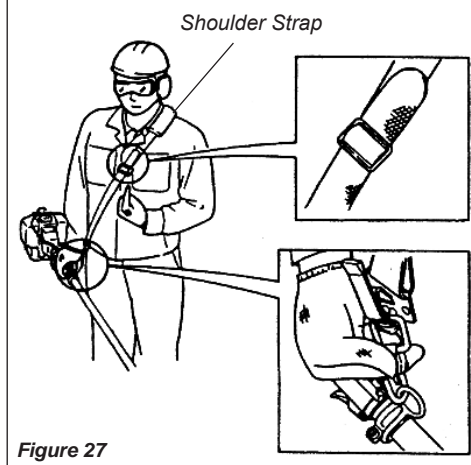

Figure 27

### IMPORTANT!

Adjust the shoulder strap or harness so the shoulder pad rests comfortably on the off-side shoulder and the cutting path of the cutting attachment is parallel to the ground. Make sure all hooks and adjustment devices are secure.

### WARNING!

Always wear a shoulder strap when operating this unit with a blade. A shoulder strap is also recommended when using trimmer line.

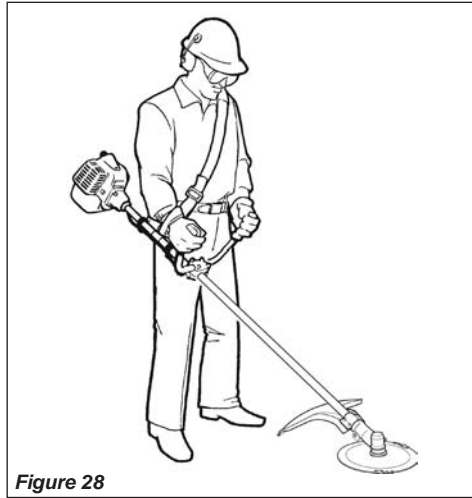

Figure 28

### NOTE:

Using a shoulder strap with a brushcutter allows you to maintain proper control of the unit and reduces fatigue during extended operation.

## Emergency Release

In case of emergency, strongly pull the white tab at the hook. The machine will be released from the strap.

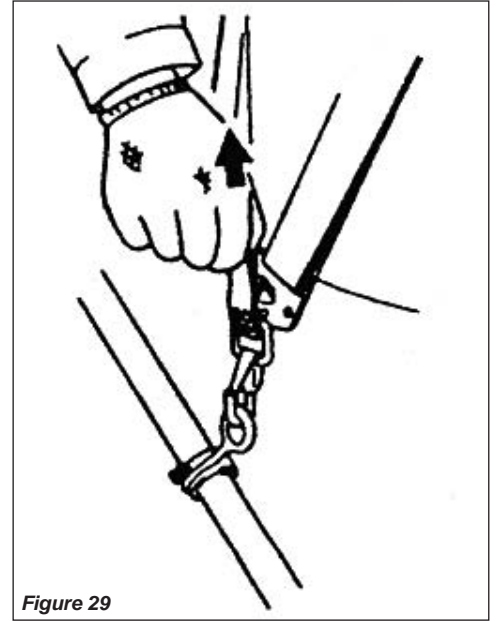

Figure 29

# Cutting Grass—Units equipped With a Trimmer Head

Your Shindaiwa unit may be equipped with one of several Shindaiwa trimmer head models, each with features for specific applications and/or operational requirements.

### NOTE:

For proper operation, always refer to the instructions accompanying the trimmer head being used. Available trimmer head styles include:

- **Semi-automatic.** Trimmer line is indexed when the operator taps the trimmer head on the ground during operation.
- **Manual.** The operator indexes line manually with the grass trimmer stopped.
- **Fixed.** The operator must stop the unit and add new lengths of trimmer line manually.
- **Flail.** This device, designed for clearing weeds and light brush, features three nylon blades attached to the head by pivots.

### NOTE:

Additional hardware may be required to mount the Fixed Line or the Flail type trimmer heads.

### CAUTION!

Do not push the rotating line into trees, wire fences or any material that could tangle or break line ends.

## Engine Operating Speeds

Operate the unit at full throttle while cutting grass.

### CAUTION!

Operation of trimmer without a cutting attachment shield and using excessive line length can lead to premature clutch failure.

### CAUTION!

Operation at low speeds can lead to premature clutch failure.

## Trimming and Mowing Grass

Hold the trimmer so the trimmer head is angled slightly into the area to be cut. To ensure maximum trimmer-line service life, cut only with the tip of the trimmer line. Cut grass by swinging the trimmer from

left to right. Keep the trimmer head horizontal. See Figure 30.

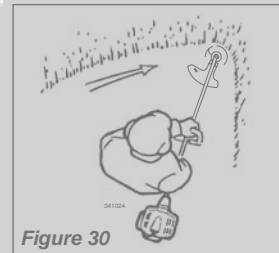

Figure 30

## Edging

Tilt the handle about 100° to the left (from horizontal) and move forward, holding the trimmer vertically as shown in Figure 31.

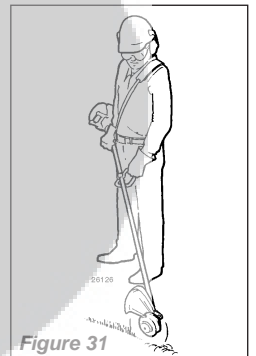

Figure 31

## Using a Blade T242/C242

### WARNING!

- Before working with a blade-equipped unit, always inspect and clean the area of objects that could interfere with or damage the blade.
- Never use a blade near sidewalks, fence posts, buildings or other objects that could cause injury or damage.
- Never use a blade for purposes other than those for which it was designed.
- Whenever you strike a hard object with a blade, always stop the brushcutter and carefully inspect the blade for damage. **NEVER OPERATE THE BRUSHCUTTER WITH A DAMAGED BLADE!**
- A blade-equipped unit must be equipped with a bicycle-type handlebar or barrier bar as well as a harness or shoulder strap.
- Always make sure the cutting attachment shield is properly installed before operating this unit.

### Blade Thrust

'Blade thrust' is a sudden sideways or backward motion of the brushcutter. Such motion may occur when the blade jams or catches on an object such as a sapling tree or tree stump. **BE CONSTANTLY ALERT FOR BLADE THRUST AND GUARD AGAINST ITS EFFECTS!**

### Brushcutter Handlebar

A brushcutter handlebar or barrier bar helps prevent the operator from moving forward, or the unit moving rearward, thus preventing inadvertent bodily contact with the blade. **ALWAYS KEEP THE HANDLEBAR OR BARRIER BAR SECURELY IN PLACE ON THE UNIT!**

## Using a Blade T242/C242

The blade rotates counter-clockwise. For best performance and to minimize being stuck by debris, move the blade from right to left while advancing on your work. Position the blade so cuts are made between the blade's 8 o'clock and 10 o'clock positions (as viewed from above). **DO NOT** cut between the 10 o'clock and 5 o'clock positions.

### WARNING!

When cutting wood with a saw, feed the blade slowly—never strike or "slam" a spinning blade against the wood.

### WARNING!

**DO NOT** use 2-tooth or non-Shindaiwa approved 4-tooth cutting blades with Shindaiwa trimmers and brushcutters.

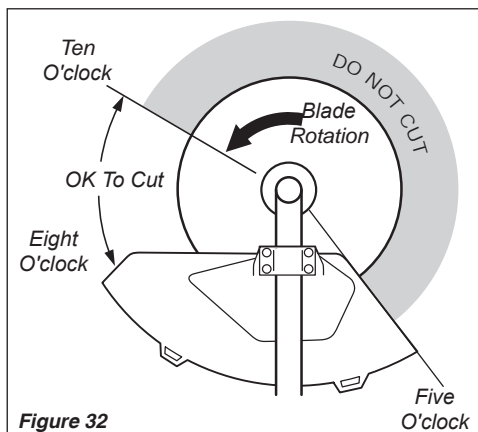

### Vertical Cuts

Hold the brushcutter with the blade at a 90° angle to the ground so the blade's bottom edge rotates toward the operator. Move the blade from top to bottom through the cut, and cut only with the bottom edge of the blade.

### WARNING!

When making vertical cuts, never allow the blade to exceed waist height.

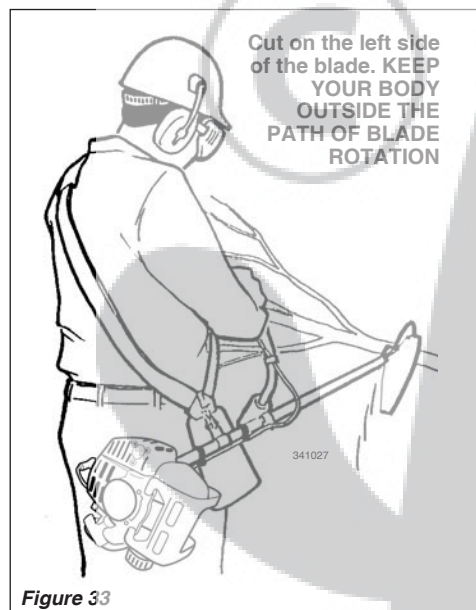

### Brushcutter Shoulder Strap

A shoulder strap provides additional protection against blade thrust. In addition, a shoulder strap gives significant support and comfort to help ensure safe and efficient operation. When operating a T242/C242 with a blade, make sure both the handle and shoulder strap are adjusted to the size of the operator using the unit.

### Engine Operating Speeds

Operate the unit at full throttle while cutting. Best fuel efficiency is obtained by releasing the throttle when swinging back after a cut.

- To prevent possible engine damage, do not allow the brushcutter to run at high speeds without a load.
- Avoid operating the engine at low speeds. Doing so can lead to rapid clutch wear. In addition, slow-speed operation tends to cause grass and debris to wrap around the cutting head.

## Recommended Cutting Attachments

Make sure to use the following recommended Shindaiwa cutting attachment with this machine.

PART NUMBER 60903-98310  
8-TOOTH BLADE  
INNER BORE: 25.4 mm  
DIAMETER: 255.0 mm  
THICKNESS: 2.0 mm



PART NUMBER 60903-98320  
4-TOOTH BLADE  
INNER BORE: 25.4 mm  
DIAMETER: 255.0 mm  
THICKNESS: 2.0 mm



PART NUMBER 78809-12000  
SPEED FEED 3.75 TRIMMER HEAD  
BOLT DIAMETER: 7 mm  
THREAD:  
LEFT, 1.0 mm PITCH



PART NUMBER 72430-92142  
3-TOOTH BLADE  
INNER BORE: 25.4mm  
DIAMETER: 255.0mm  
THICKNESS: 2.2mm



## General Maintenance



### WARNING!

Before performing any maintenance, repair or cleaning work on the unit, make sure the engine and cutting attachment are completely stopped. Disconnect the spark plug wire before performing service or maintenance work.



### WARNING!

Non-standard parts may not operate properly with your unit and may cause damage and lead to personal injury.

### Spark Plug

Keep the spark plug and wire connections tight and clean.

## Daily Maintenance

### Prior to each work day, perform the following:

- Remove all dirt and debris from the engine, check the cooling fins and air cleaner for clogging, and clean as necessary.

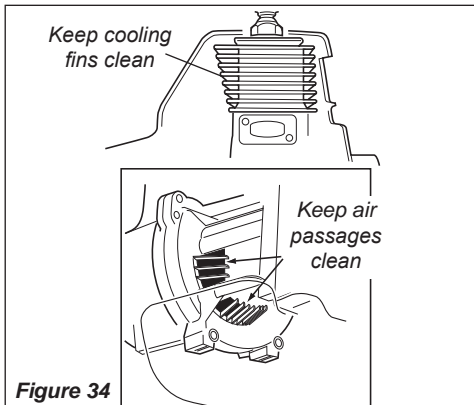

- Carefully remove any accumulations of dirt or debris from the muffler and fuel tank. Check cooling air intake area at base of crankcase. Remove all debris. Dirt build-up in these areas can lead to engine overheating, fire, or premature wear.
- Clean any debris or dirt from the cutting attachment.
- Check for loose or missing screws or components. Make sure the cutting attachment is securely fastened.
- Check the entire unit for leaking fuel or grease.
- Make sure nuts, bolts, and screws (except carburetor idle speed adjusting screws) are tight.

## 10-Hour Maintenance

### NOTE:

If the machine is used in dusty or dirty conditions, perform the periodic maintenance more frequently.

- Remove the air cleaner filter. Clean or replace as necessary. To clean filter wash it thoroughly in soap and water. Let it dry before reinstalling the filter.

### CAUTION!

Do not operate the unit if the air cleaner or filter is damaged, or if the filter is wet or water soaked.

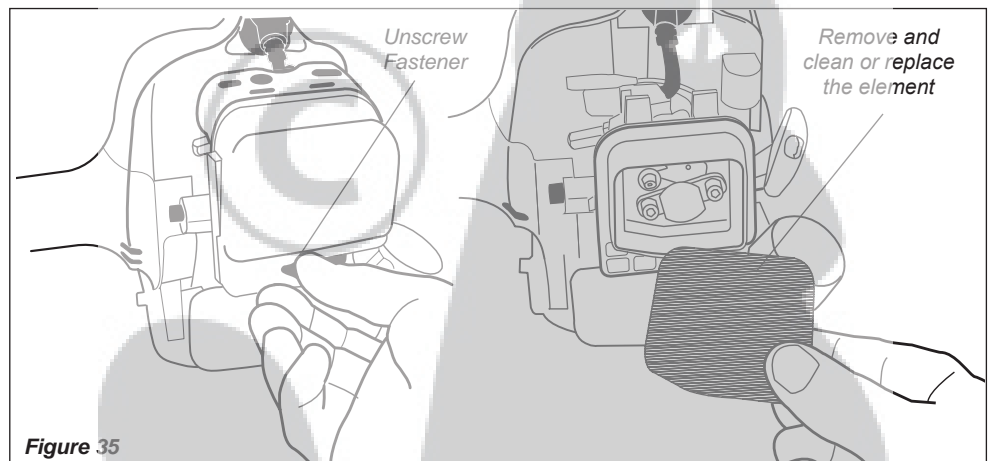
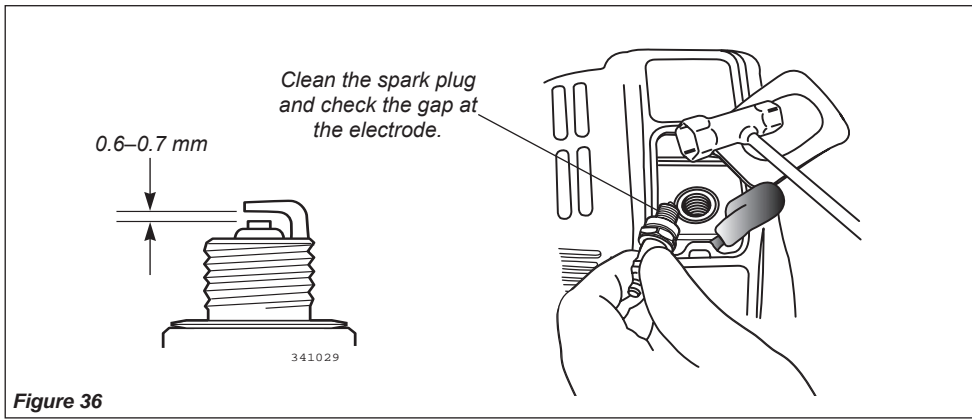

Figure 35

## 10/15-Hour Maintenance



Every 10 to 15 hours of operation:

- Remove and clean the spark plug. Adjust the spark plug electrode gap to 0.6 - 0.7 mm. If the spark plug must be replaced, use only an NGK BPR6A or equivalent resistor type spark plug of the correct heat range. See Figure 36.

### NOTE:

The NGK BPR6A also meets the requirements for electro magnetic compliance (EMC).

### CAUTION!

Before removing the spark plug, clean the area around the plug to prevent dirt and debris from getting into the engine's internal parts.

## 50-Hour Maintenance

Every 50 hours of operation (more frequently in dusty or dirty conditions):

- Remove and clean the cylinder cover and clean grass and dirt from the cylinder fins.
- Remove the cutting attachment, cutting attachment holder and gear shaft collar. Remove the filler plug from the side of the gearcase and press new grease into the gearcase until old grease is pushed out. Use only lithium-base grease such as Shindaiwa Gearcase Lubricant or equivalent. See Figure 37.
- Lubricate main shaft splines.
- Use a hooked wire to extract the fuel filter from inside the fuel tank. See Figure 38.

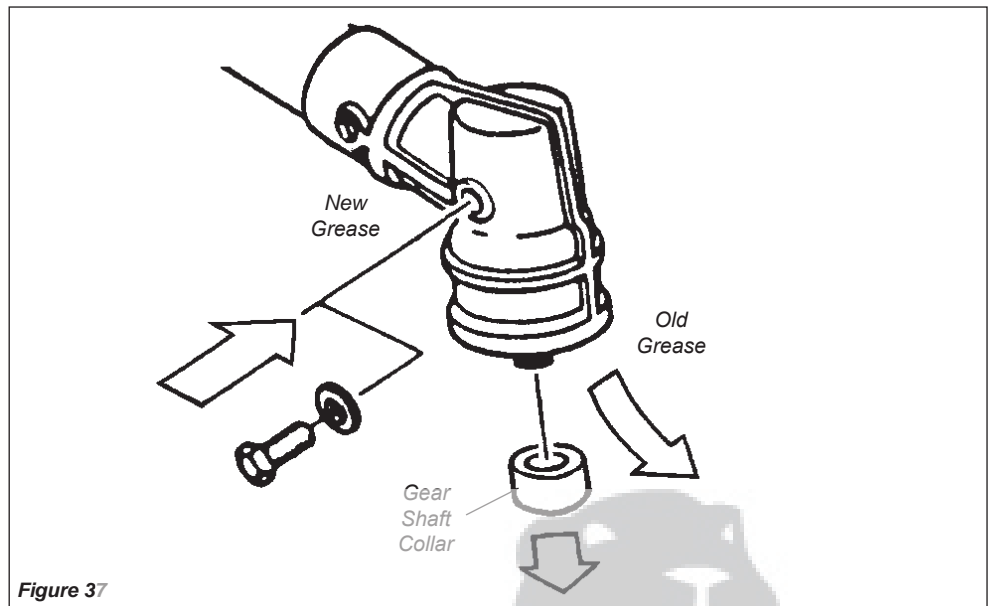

### CAUTION!

Make sure you do not pierce the fuel line with the end of the hooked wire. The line is delicate and can be damaged easily.

- Remove and replace the filter element. Before reinstalling the new filter element, inspect the condition of all the fuel system components (fuel pick-up line, fuel return line, tank vent line, tank vent, fuel cap and fuel tank). If damage, splitting or deterioration is noted, the unit should be removed from service until it can be inspected or repaired by a Shindaiwa-trained service technician.

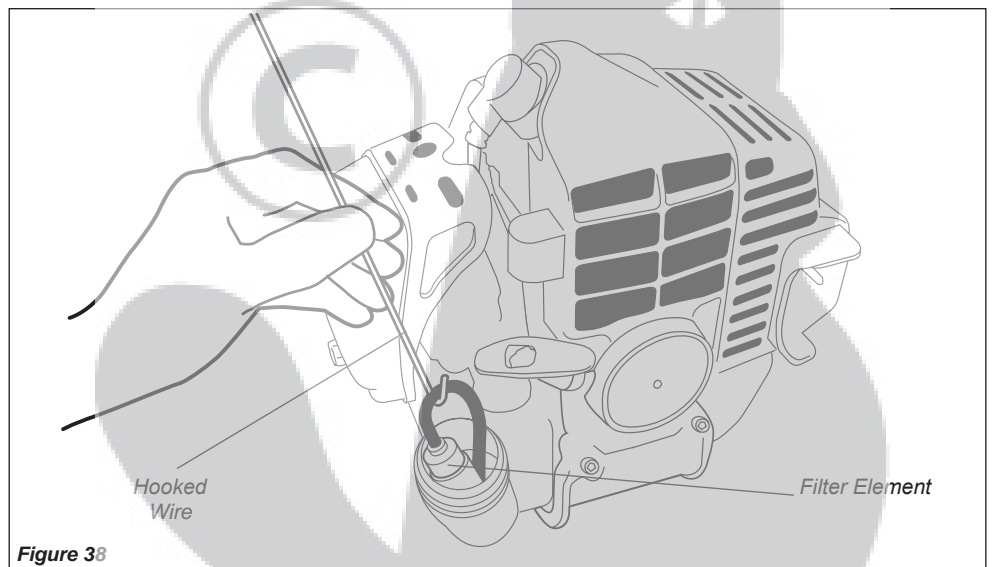



## 135-hour Maintenance

Every 135 hours of operation, remove and clean the muffler.



### WARNING!

Never operate this trimmer with a damaged or missing muffler or spark arrester! Operating with missing or damaged exhaust components is a fire hazard, and can also damage your hearing!

1. Remove the spark plug boot.
2. With a 3 mm hex wrench remove the 1 muffler cover and 3 engine cover screws and the engine cover. See Figure 39.
3. With a Phillips type screwdriver remove the 5 screws holding the spark arrester screen and cover to the muffler. See Figure 39.
4. Remove the screen and clean it with a stiff bristle brush.
5. With a 4 mm hex wrench remove the 3 muffler bolts and the muffler. See Figure 39.
6. Inspect the cylinder exhaust port for any carbon buildup.
7. Gently tap the muffler on a wood surface to dislodge any loose carbon.

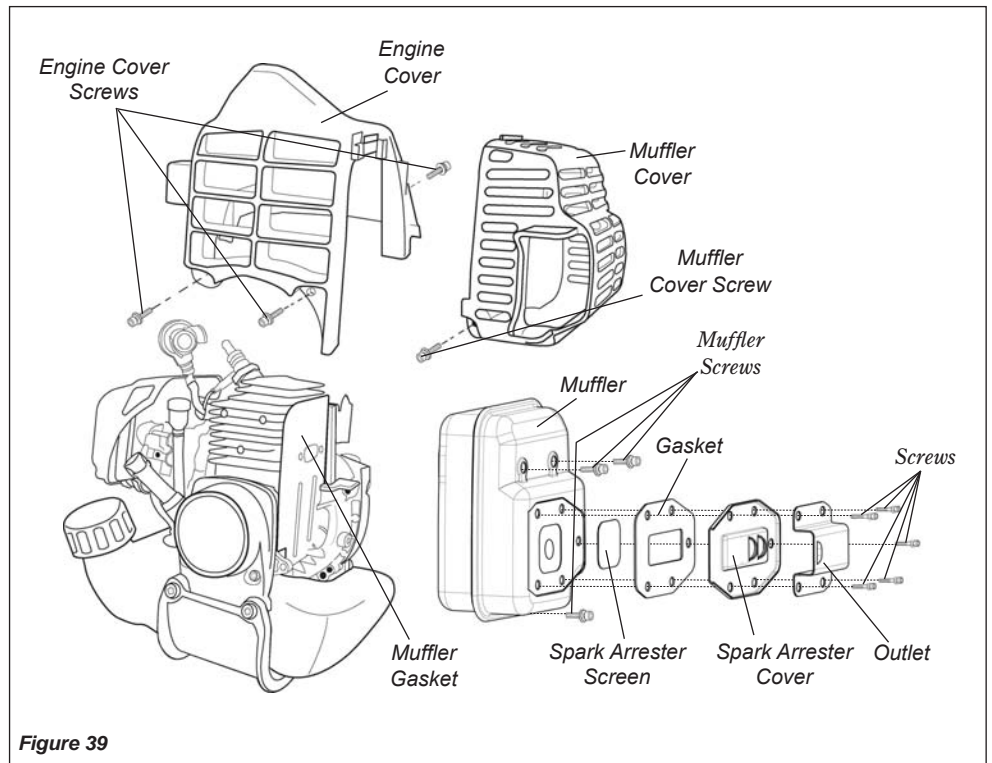
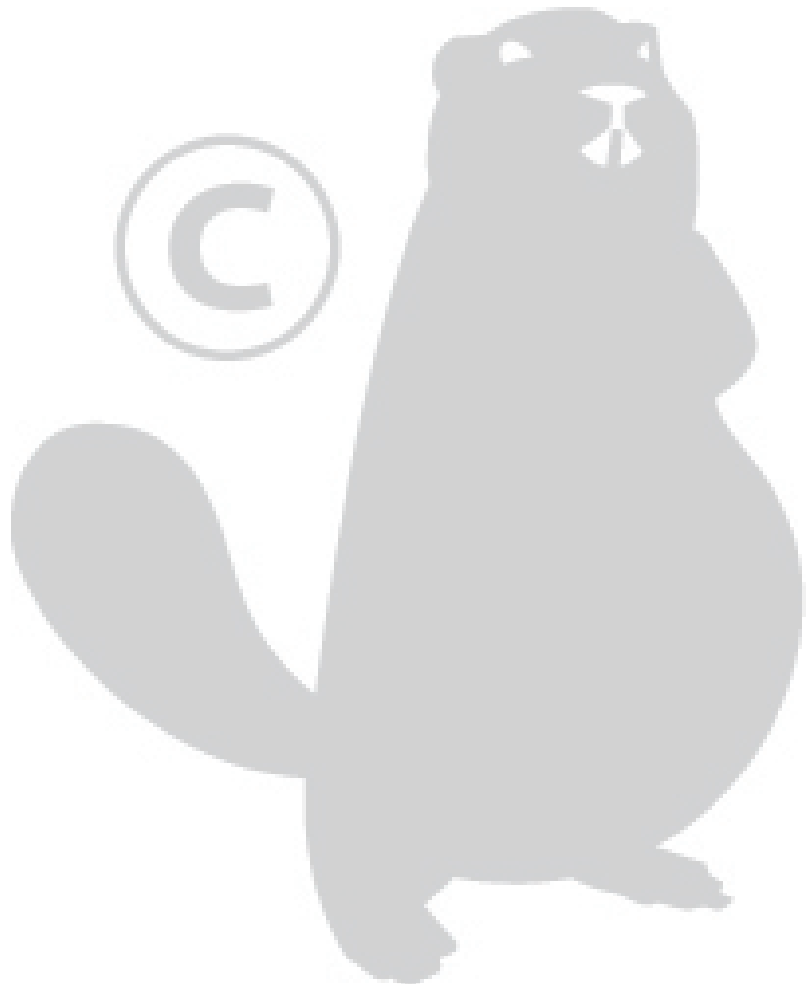

Figure 39

### IMPORTANT!

If you note excessive carbon buildup, consult with an authorized Shindaiwa servicing dealer.

8. Reassemble the spark arrester, muffler and engine cover in the reverse order of disassembly.



## Long Term Storage

Whenever the unit will not be used for **30 days or longer**, use the following procedures to prepare it for storage:

- Clean external parts thoroughly.
- Drain all the fuel from the fuel tank.

### IMPORTANT!

All stored fuels should be stabilized with a fuel stabilizer such as STA-BIL™, if **ONE** oil with fuel stabilizer is not used.

### CAUTION!

Gasoline stored in the carburetor for extended periods can cause hard starting and could also lead to increased service and maintenance cost.

- Remove the remaining fuel from the fuel lines and carburetor.
1. Prime the primer bulb until no more fuel is passing through.
  2. Start and run the engine until it stops running.
  3. Repeat steps 1 and 2 until the engine will no longer start.

- Remove the spark plug and pour about 7 ml of 2-cycle mixing oil into the cylinder through the spark plug hole. Slowly pull the recoil starter 2 or 3 times so oil will evenly coat the interior of the engine. Reinstall the spark plug.
- Before storing the unit, repair or replace any worn or damaged parts.
- Remove the air cleaner element from the carburetor and clean it thoroughly with soap and water. Let dry and reassemble the element.
- Store the unit in a clean, dust-free area.

## Blade Sharpening

With the file or a grinder, file a blade as follows.



### WARNING!

Sharpen only the cutting teeth of a blade. **DO NOT** alter the contour of the blade in any way. In order to keep the blade in balance, all cutting edges must be sharpened equally. **DO NOT** file the tips of the teeth too sharp.

The sharpening angle should be 45° approximately.  
Do not file the tips of the blade too sharp. leave 0.2 ~ 0.5 mm unsharpened.

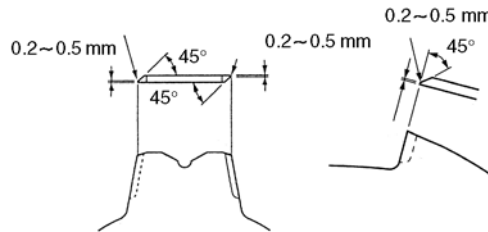

Figure 41

Make sure the width of all cutting teeth are the same.

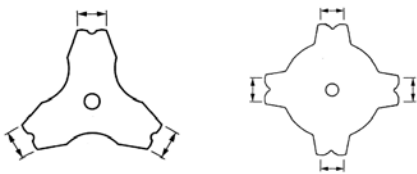

Figure 40

The bottom of each tooth must remain unsharpened. (Blade as viewed from bottom.)

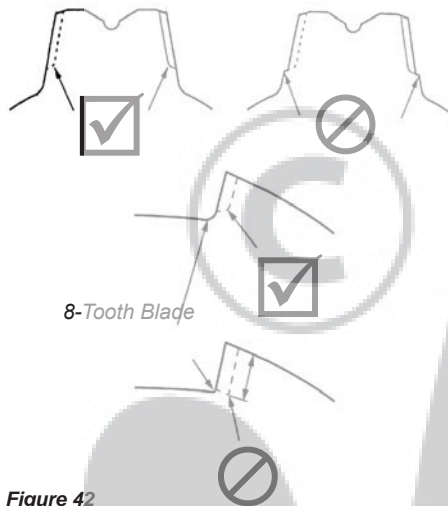

Figure 42

## ENGINE DOES NOT START

What To Check	Possible Cause	Remedy
Does the engine crank? ↓ YES	NO Faulty recoil starter. Fluid in the crankcase. Internal damage.	Consult with an authorized servicing dealer.
Good compression? ↓ YES	NO Loose spark plug. Excess wear on cylinder, piston, rings.	Tighten and re-test. Consult with an authorized servicing dealer.
Does the tank contain fresh fuel of the proper grade? ↓ YES	NO Fuel incorrect, stale, or contaminated; mixture incorrect.	Refill with fresh, clean unleaded gasoline with a pump octane of 87 or higher mixed with a 2-cycle air cooled mixing oil that meets or exceeds ISO-L-EGD and/or JASO FC classified oils at 50:1 gasoline/oil ratio.
Is fuel visible and moving in the return line when priming? ↓ YES	NO Check for clogged fuel filter and/or vent. Priming pump not functioning properly.	Replace fuel filter or vent as required. restart. Consult with an authorized servicing dealer.
Is there spark at the spark plug wire terminal? ↓ YES	NO The ignition switch is in "O" (OFF) position. Shorted ignition ground. Faulty ignition unit.	Move switch to "I" (ON) position and re-start. Consult with an authorized servicing dealer.
Check the spark plug.	NO If the plug is wet, excess fuel may be in the cylinder. The plug is fouled or improperly gapped. The plug is damaged internally or of the wrong size.	Crank the engine with the plug removed, reinstall the plug, and restart. Clean and regap the plug to 0.6 - 0.7 mm. Restart. Replace the plug with an NGK BPMR6A or equivalent resistor type spark plug of the correct range. Set spark plug electrode gap to 0.6-0.7 mm.

## LOW POWER OUTPUT

What To Check	Possible Cause	Remedy
Is the engine overheating?	Operator is overworking the unit. Carburetor mixture is too lean. Improper fuel ratio. Fan, fan cover, cylinder fins dirty or damaged. Carbon deposits on the piston or in the muffler.	Shorten trimmer line. Cut at a slower rate. Consult with an authorized servicing dealer. Refill with fresh, clean unleaded gasoline with a pump octane of 87 or higher mixed with a 2-cycle air cooled mixing oil that meets or exceeds ISO-L-EGD and/or JASO FC classified oils at 50:1 gasoline/oil ratio. Clean, repair or replace as necessary. Consult with an authorized servicing dealer.
Engine is rough at all speeds. May also have black smoke an/ or unburned fuel at the exhaust.	Clogged air cleaner element. Loose or damaged spark plug. Air leakage or clogged fuel line. Water in the fuel. Piston seizure. Faulty carburetor and/or diaphragm.	Service the air cleaner element. Tighten or replace. Repair or replace fuel filter and/or fuel line. Replace the fuel. See page 11. Consult with an authorized servicing dealer.
Engine is knocking.	Overheating condition. Improper fuel. Carbon deposits in the combustion chamber.	See above. Check fuel octane rating; check for presence of alcohol in the fuel (page 11). Refuel as necessary. Consult with an authorized servicing dealer.

Symptom	Possible Cause	Remedy
Poor acceleration.	<ul style="list-style-type: none"> <li>Clogged air filter.</li> <li>Clogged fuel filter.</li> <li>Lean fuel/air mixture.</li> <li>Idle speed set too low.</li> </ul>	<ul style="list-style-type: none"> <li>Clean the air filter.</li> <li>Replace the fuel filter.</li> <li>Consult with an authorized servicing dealer.</li> <li>2,750(±250) rpm min<sup>-1</sup>.</li> </ul>
Engine stops abruptly.	<ul style="list-style-type: none"> <li>Switch turned off.</li> <li>Fuel tank empty.</li> <li>Clogged fuel filter.</li> <li>Water in the fuel.</li> <li>Shorted spark plug or loose terminal.</li> <li>Ignition failure.</li> <li>Piston seizure.</li> </ul>	<ul style="list-style-type: none"> <li>Reset the switch and re-start.</li> <li>Refuel. See page 11.</li> <li>Replace fuel filter.</li> <li>Drain; replace with clean fuel. See page 11.</li> <li>Clean or replace spark plug, tighten the terminal.</li> <li>Replace the ignition unit.</li> <li>Consult with an authorized servicing dealer.</li> </ul>
Engine difficult to shut off.	<ul style="list-style-type: none"> <li>Ground (stop) wire is disconnected, or switch is defective.</li> <li>Overheating due to incorrect spark plug.</li> <li>Overheated engine.</li> </ul>	<ul style="list-style-type: none"> <li>Test and replace as required.</li> <li>Idle engine until cool. Clean and regap the plug to 0.6 - 0.7 mm. Correct plug: NGK BPMR6A or equivalent resistor type spark plug of the correct range.</li> <li>Idle engine until cool.</li> </ul>
Cutting attachment rotates at engine idle.	<ul style="list-style-type: none"> <li>Engine idle too high.</li> <li>Broken clutch spring or worn clutch spring boss.</li> <li>Loose attachment holder.</li> </ul>	<ul style="list-style-type: none"> <li>2,750(±250) rpm min<sup>-1</sup>.</li> <li>Replace spring/shoes as required, check idle speed.</li> <li>Inspect and re-tighten holders securely.</li> </ul>
Engine will not idle down.	<ul style="list-style-type: none"> <li>Engine idle set too high.</li> <li>Engine has an air leak.</li> </ul>	<ul style="list-style-type: none"> <li>2,750(±250) rpm min<sup>-1</sup>.</li> <li>Consult with an authorized servicing dealer.</li> </ul>
Excessive vibration.	<ul style="list-style-type: none"> <li>Warped or damaged cutting attachment.</li> <li>Loose gearcase.</li> <li>Bent main shaft/worn or damaged bushings.</li> <li>Trimmer line not wound properly on spool.</li> </ul>	<ul style="list-style-type: none"> <li>Inspect and replace attachment as required.</li> <li>Tighten gearcase securely.</li> <li>Inspect and replace as necessary.</li> <li>Rewind trimmer line.</li> </ul>
Cutting attachment will not rotate.	<ul style="list-style-type: none"> <li>Shaft not installed in powerhead or gearcase.</li> <li>Broken shaft.</li> <li>Damaged gearcase.</li> </ul>	<ul style="list-style-type: none"> <li>Inspect and reinstall as required.</li> <li>Consult with an authorized servicing dealer.</li> </ul>



# DECLARATION OF CONFORMITY

We hereby declare the Shindaiwa Engine Brushcutter,  
Model R242 (T242XS/EC2, C242S/EC2),

meets the following respective requirements.

Council Directives:

89/336/EEC as amended

98/37/EC as amended

2000/14/EC as amended

2004/26/EC as amended

Standard taken:

ISO 12100- 1&2

ISO 11806

CISPR 12

Measured sound power level: 109dB(A)

Guaranteed sound power level: 110dB(A)

Technical documentation is kept by:

K. Maeda DIV. Manager

Engineering Research and Development DIV.

**Shindaiwa Corporation**

Head office : 6-2-11, Ozuka-Nishi, Asaminami-Ku,  
Hiroshima, 731-3167, Japan

TEL: 81-82-849-2003, FAX: 81-82-849-2482

2 March, 2007



T. Yoshitomi

DIV. Manager

Quality Assurance DIV.

**Shindaiwa Corporation**

Head office : 6-2-11, Ozuka-Nishi, Asaminami-Ku,  
Hiroshima, 731-3167, Japan

TEL: 81-82-849-2206, FAX: 81-82-849-2481

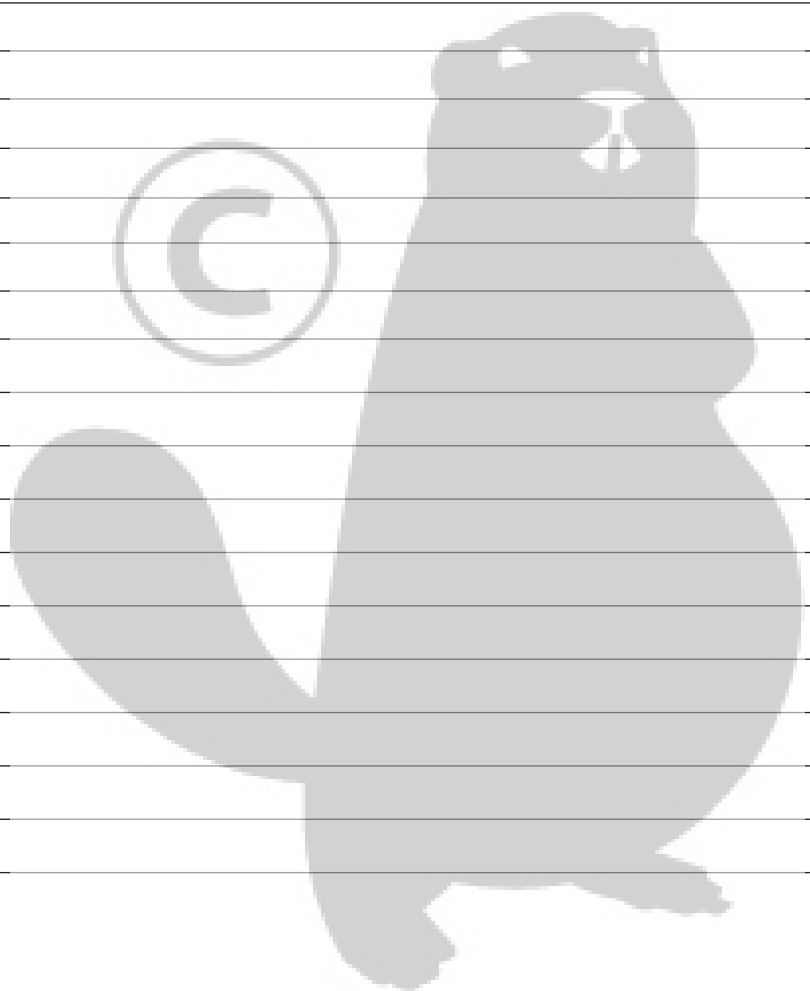

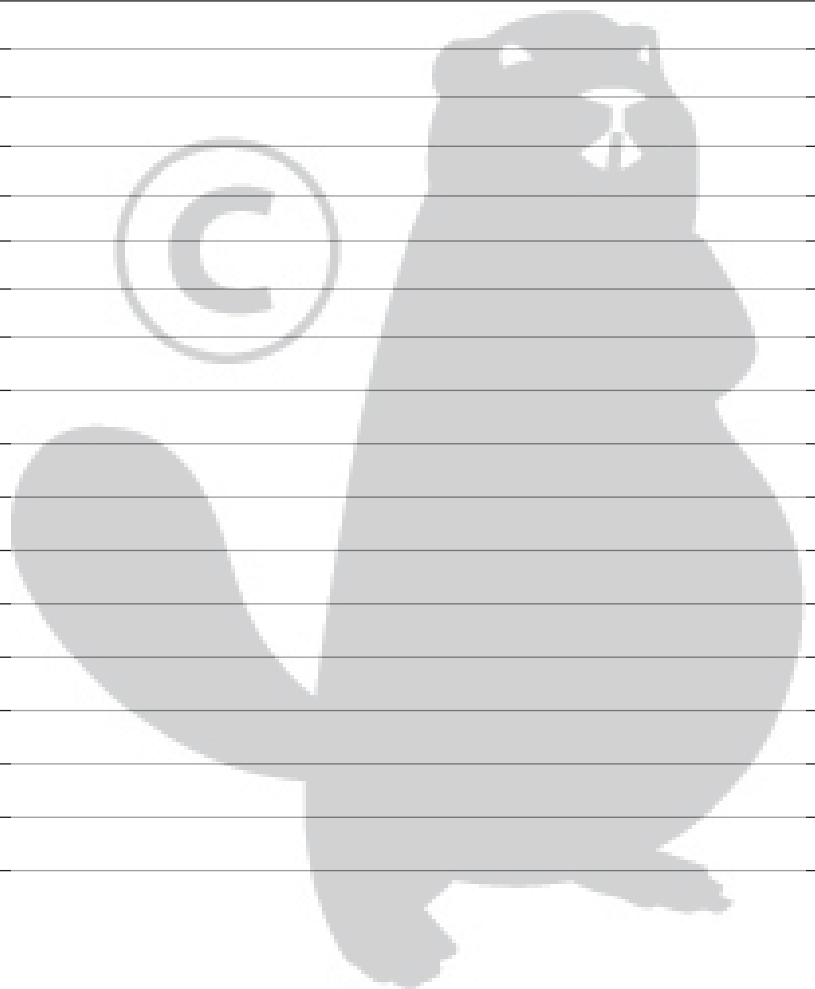

NOTES:

**shindaiwa**

Shindaiwa Inc.  
11975 S.W. Herman Rd.  
Tualatin, Oregon 97062 USA  
Telephone: 503 692-3070  
Fax: 503 692-6696  
www.shindaiwa.com

Shindaiwa Corporation  
Head Office:  
6-2-11, Ozuka-Nishi  
Asaminami-Ku, Hiroshima  
731-3167, Japan  
Telephone: 81-82-849-2220  
Fax: 81-82-849-2481

©2007 Shindaiwa, Inc.  
Part Number 62121-94310  
Revision 3/07

Shindaiwa is a registered trademark  
of Shindaiwa, Inc.  
Specifications subject to change without notice.

