

Lawrence Livermore National Laboratory

Si Based Pillar Structured Thermal Neutron Detectors



University of
Nebraska
Lincoln



Funded by
DHS/DNDO

Rebecca Nikolic

A.Conway¹, C. Britton³, C. Cheung², M. Dar², M.N. Ericson³, L. Fabris³, R. Radev¹, Q. Shao¹, L. Voss¹, T.F. Wang¹
LLNL¹, Univ. of Neb.², ORNL³

This work performed under the auspices of the U.S. Department of Energy by
Lawrence Livermore National Laboratory under Contract DE-AC52-07NA27344, LLNL-PRES-474261

IAEA March 23, 2011

nikolic1@llnl.gov

We are developing high-performance neutron detectors

50µm Pillar, > 90% fill

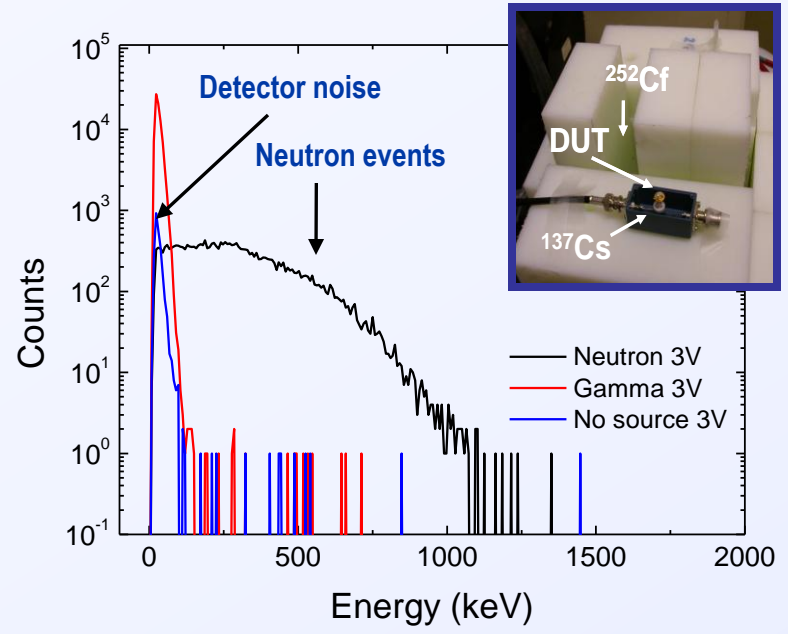
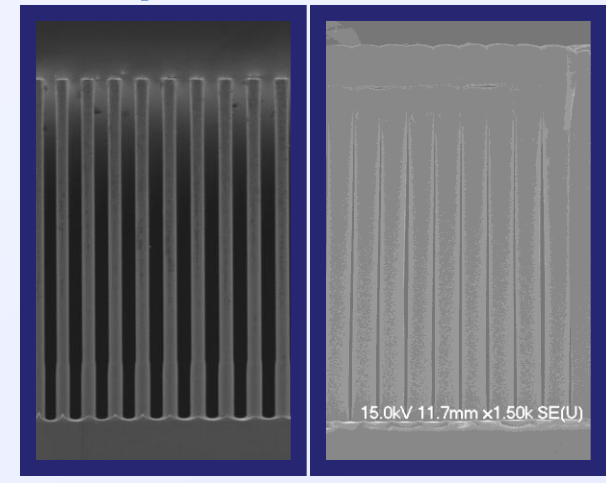

→20 % recent result (26 µm pillar)
 →10⁵ neutron/gamma discrimination

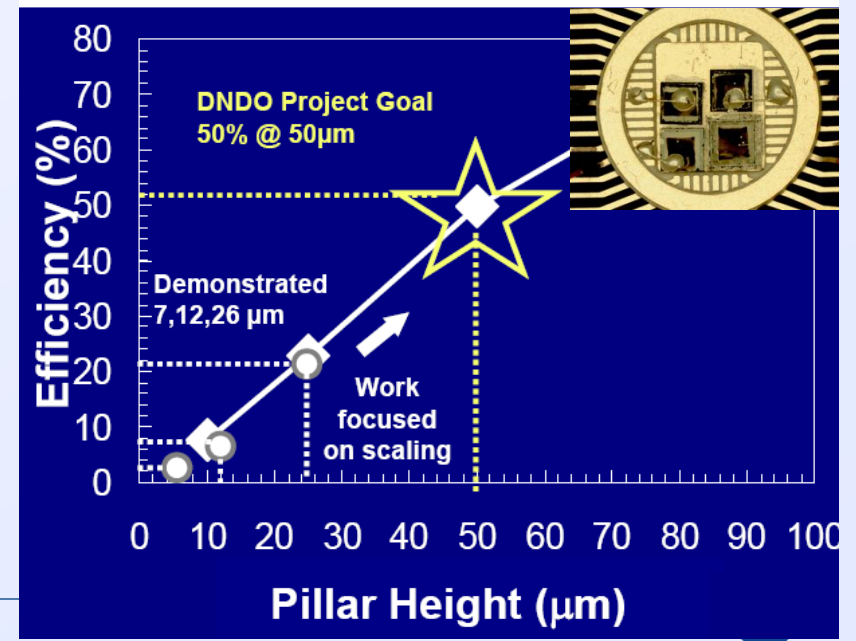

Applied Physics Letters, Vol. 93, Issue 13, Sept. 2008, p. 133502

Thermal neutron detectors are needed for the detection of SNM:

^3He tube is current standard

- ❖ ^{10}B is interspersed between silicon pillars to detect thermal neutrons
- ❖ ^{10}B chosen for high thermal neutron cross-section 3837 barns and process compatibility

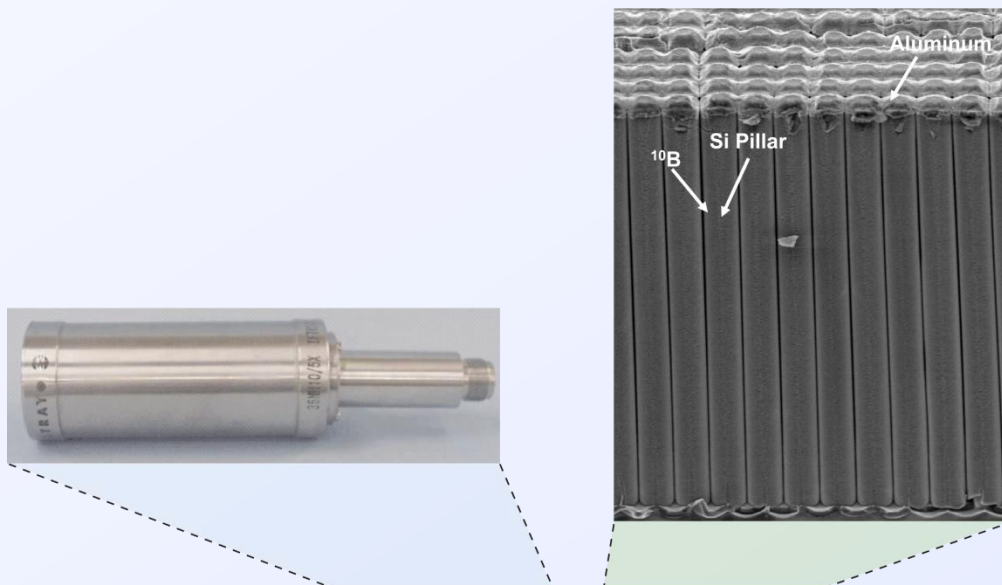

	^3He Tube	Pillar Detector
Efficiency	20–90%	50+%
Required voltage	1000 V	<10 V
Fieldability	Microphonics, HV, air transport	Rugged Not Commercial

Comparison: Thermal Neutron Converter Materials

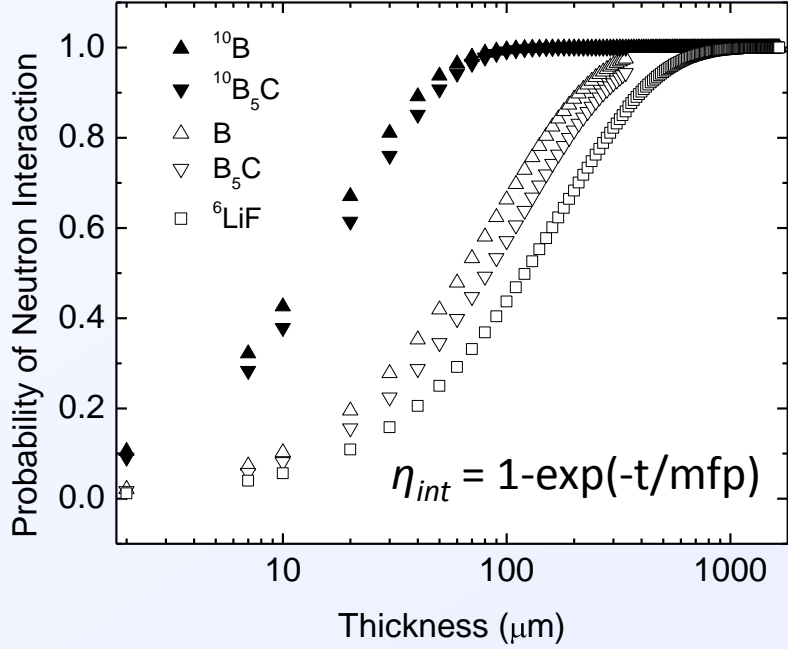

Mean free path = $1/N\sigma$ [μm]

N = number density, nuclei/volume
 σ = microscopic cross-section

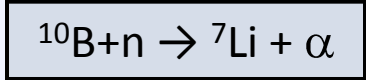

- Pillar height determined by probability of n interaction
- Pillar spacing determined by α & Li travel ranges

	1 st Excited State		Ground State	
Energy (MeV)	0.84 Li	1.47 α	1.02 Li	1.78 α
Distance in ^{10}B (μm)	1.85	3.6	2.0	4.4
Distance in Si (μm)	2.4	5.2	2.8	6.4



Pillar Detector enables high efficiency neutron detection

Standard 2D Design

Thermal neutrons

3 μm

Converter

$^{10}\text{Boron}$

$(\alpha, ^7\text{Li})$ Charged particles

Detector

+ - Electronhole pairs

- ❖ ^{10}B efficiently produces α particles

$$94\% \quad ^{10}\text{B} + n \rightarrow ^7\text{Li}(0.84\text{MeV}) + \alpha(1.47\text{MeV})$$

($Q=2.31\text{MeV}$, $\sigma=3571\text{b}$)

$$6\% \quad ^{10}\text{B} + n \rightarrow ^7\text{Li}(1.01\text{MeV}) + \alpha(1.78\text{MeV})$$

($Q=2.79\text{MeV}$, $\sigma=269\text{b}$)

- ❖ Most $\alpha/{}^7\text{Li}$ do not reach the detector
- ❖ Limited efficiency: 2-5 % (@ thermal)

LLNL 3D Design

Thermal neutrons

50 μm

4 μm pitch

^{10}B

$(\alpha, ^7\text{Li})$ Charged particles

Si

+ - Electron-hole pairs

- ❖ Simulations show 3-D structure will increase efficiency towards 50+%
- ❖ Device geometry:
 - etch depth (50 μm) \rightarrow n_0 capture
 - pitch (4 μm) \rightarrow alpha particle range

Pillar Detector Fabrication

Multi-step Process

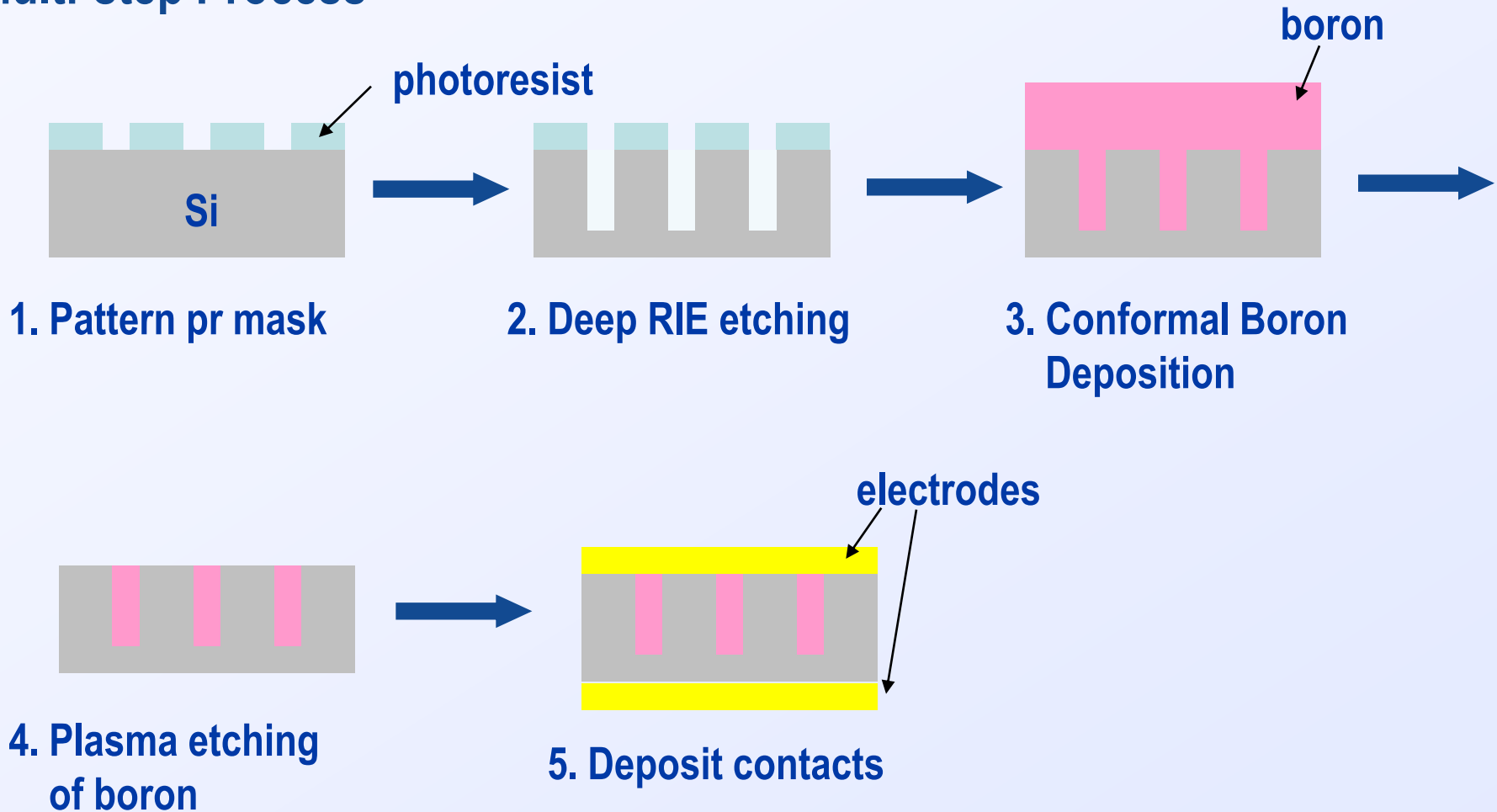

High-density plasma processing for high aspect ratio structures

Inductive-Coupled Plasma (ICP)

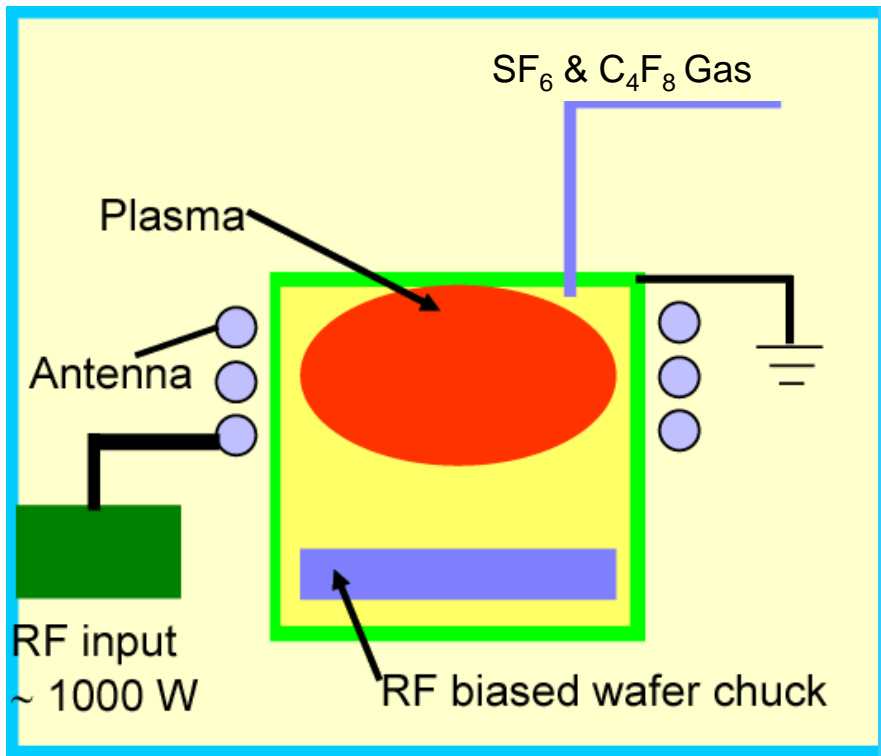

Electron Cyclotron Resonance (ECR)

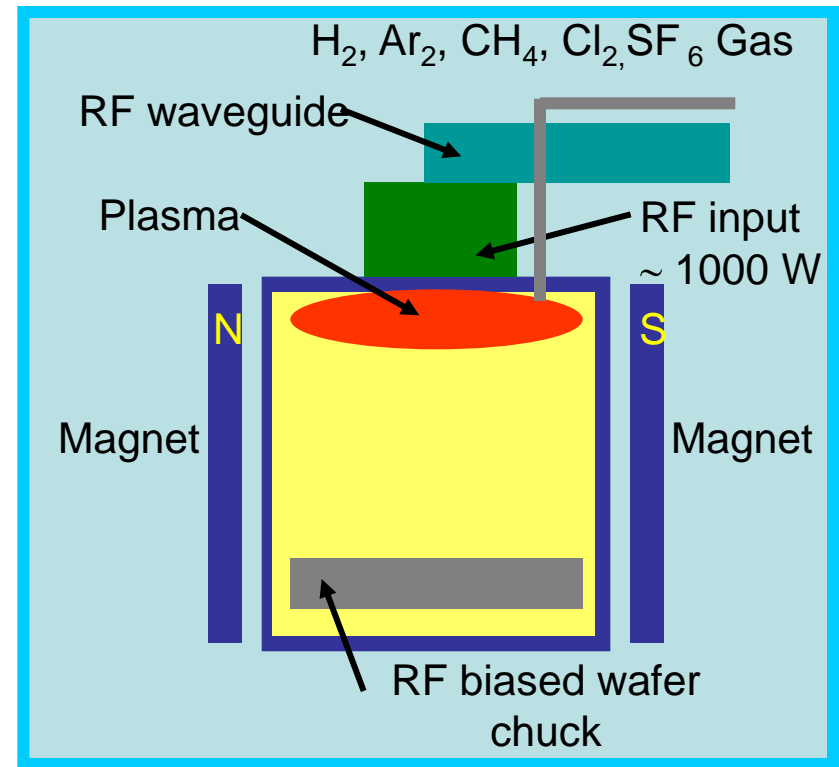

Control ion density and RF power independently

- ⇒ 1. Less damages to etched materials; 2. Flexibility in mask materials;
3. High etch rate; 4. Low substrate temperature

“Pillar” Chips for ^{10}B R&D and Detector Fabrication

Pillar Litho well-developed

- ❖ Large area pillar litho developed
- ❖ Developing negative pr process for large area

nLOF 2020

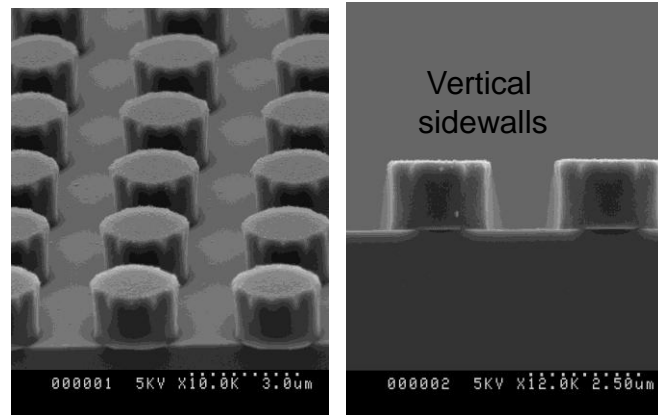

ICP Etch

- ❖ 50 μm pillar process developed
- ❖ Compatible with 2” and 4” wafers

50 μm Pillar Chips, 2 μm Width

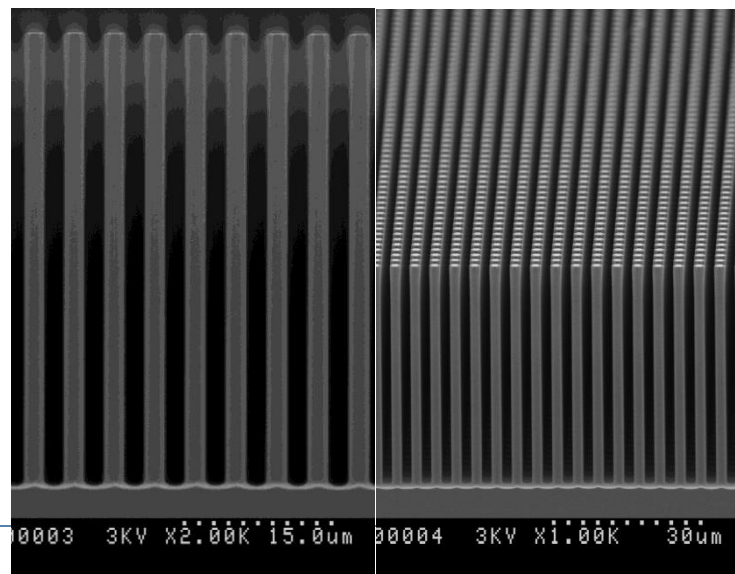

Vertical vs. Horizontal CVD System for ^{10}B Deposition



Horizontal CVD System

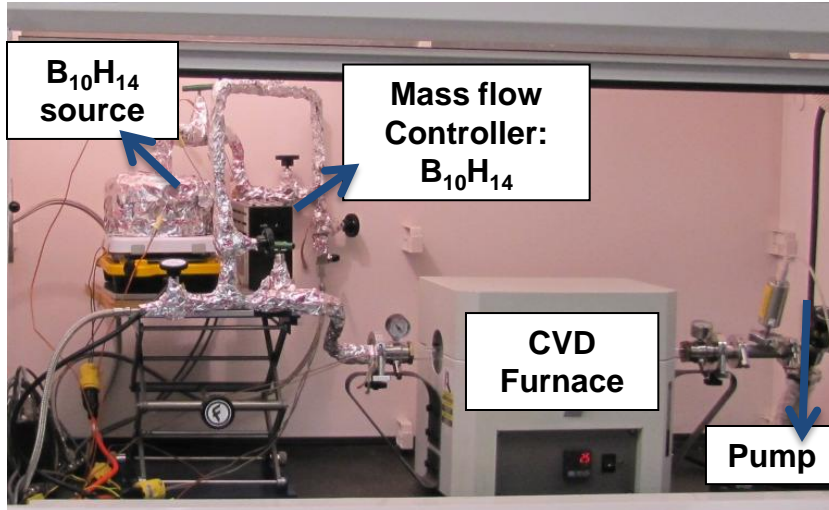

Features

- Inexpensive set up
- Easy cleaning of quartz tube chamber
- Limited control of precursor and heating profiles for samples
- Long sample loading time
- Potential for chemical exposure

Vertical CVD System

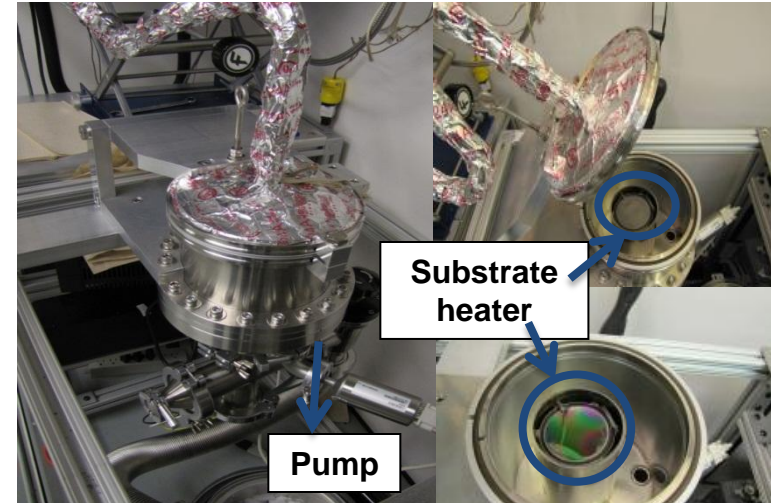

Features

- Better control of precursor and sample heating
- Quick sample loading
- Large conductance → Effective pump rate & lower operation pressure
- Tailor for scale up with larger wafers
- Low chemical exposure

Vertical CVD system provides improved **film reproducibility** and **safety**.

Activating New Vertical CVD System



Heat shielding improves heat profile and boron filling.

Vertical CVD system

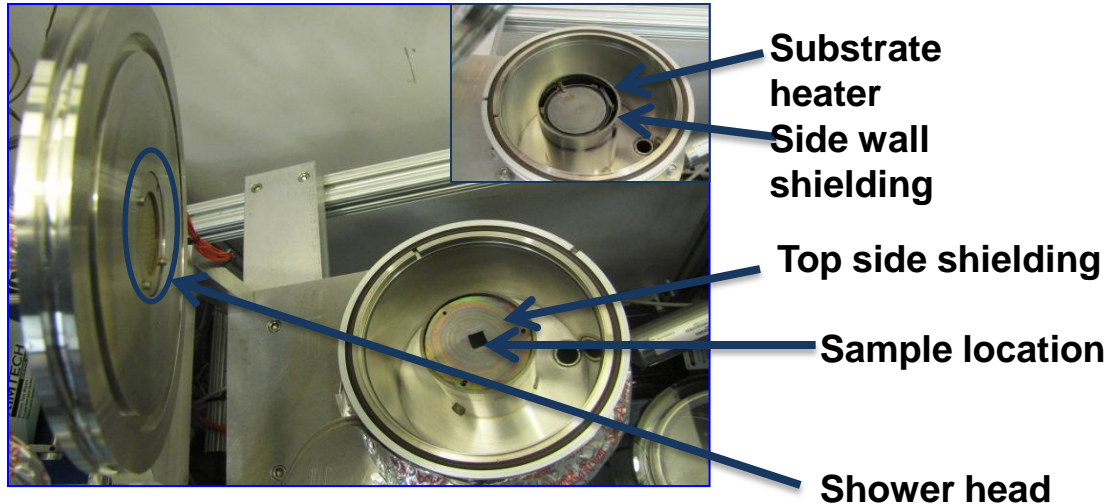

50- μ m silicon pillar samples

before boron coating

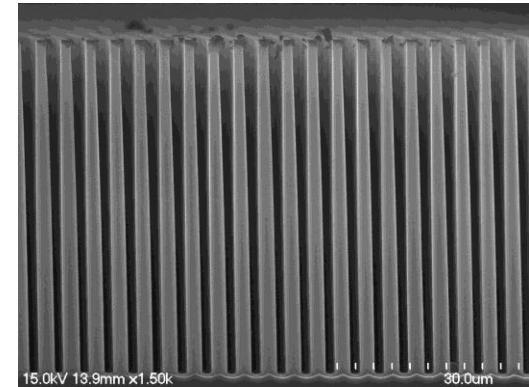

High fill factor achieved

- First device runs had low efficiency
- Optimizing vertical process in parallel with 1" CVD tube

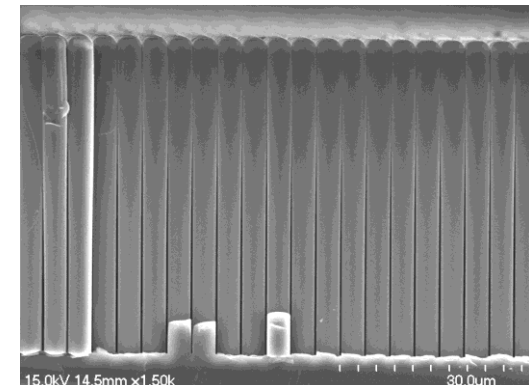
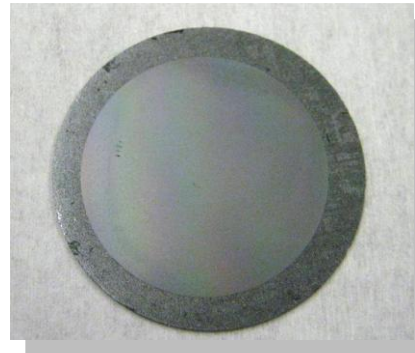

We have developed specialized processing and characterization tools for ^{10}B

Boron CVD and Etch Back

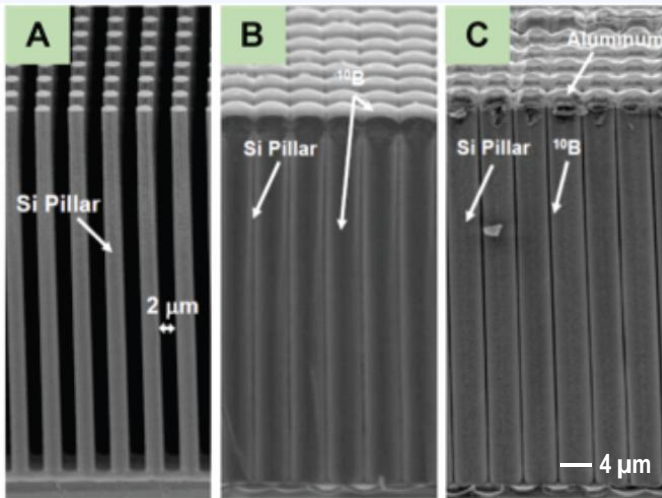

A) Pillar Platform 1:25 aspect ratio

B) Conformal boron filling

C) Rapid removal of boron with high B:Si selectivity

Raman Spectroscopy

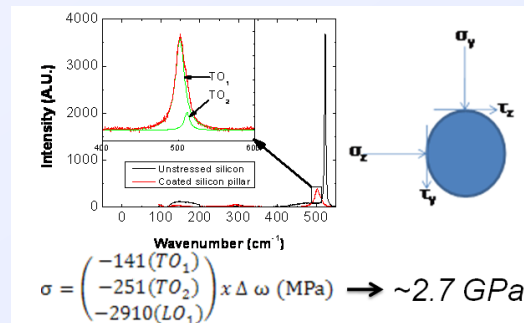

Stress induced on silicon pillars calculated from Raman shift

Stress in ^{10}B Coating

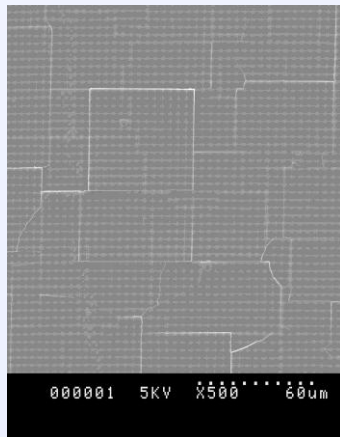

SIMS:

No B diffusion Si/B interface

Boron CVD 600 °C – 900 °C

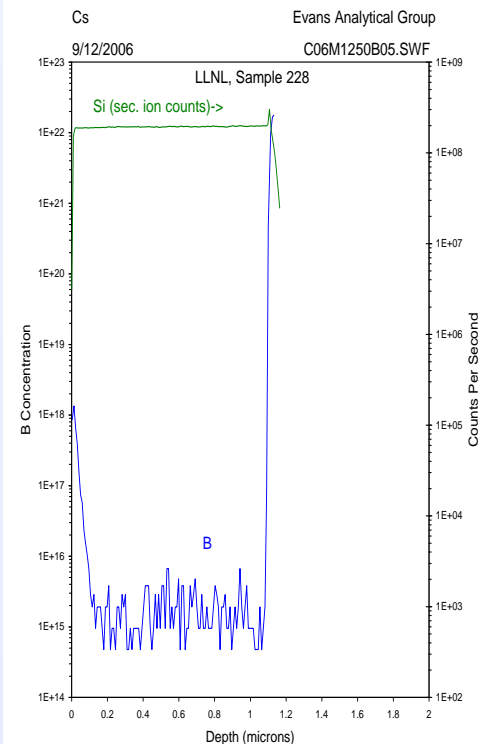



Efficiency by simulations and measurement

Simulations

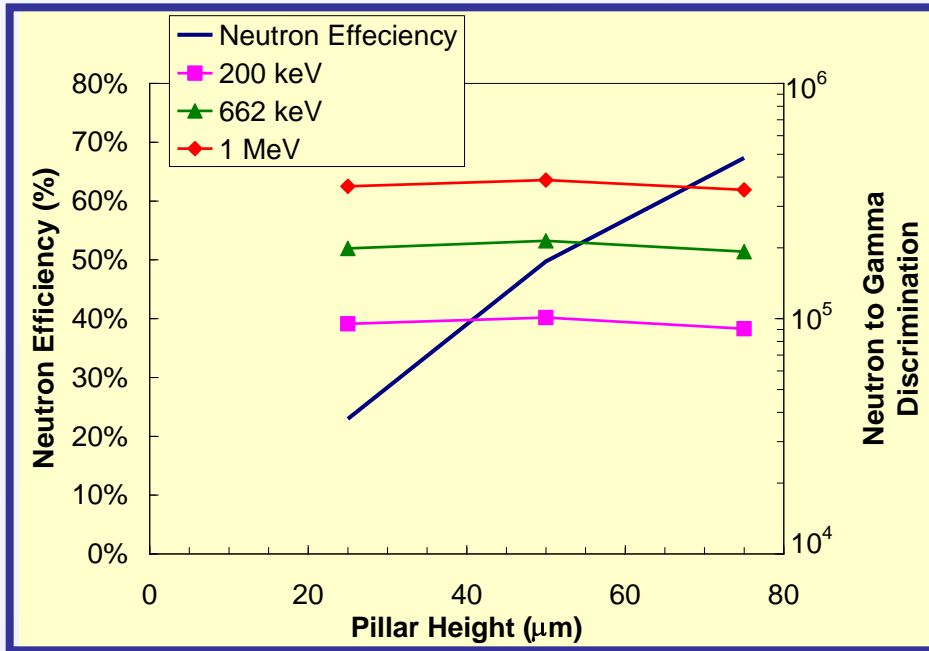

Measurements

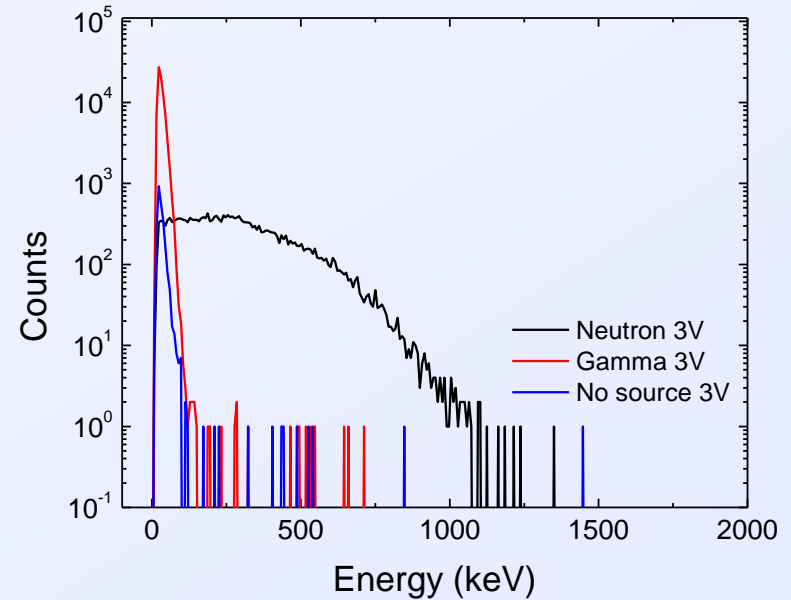

Simulation Tool-box

- MCNP → Neutron history
- TRIM → alpha, lithium trajectory
- Silvaco → semiconductor device physics

→ 20 % recent result (26 μm pillar)
→ 10⁵ neutron/gamma discrimination

We are increasing detector area and channel number

Interposer board 4 mm x 4 mm detectors

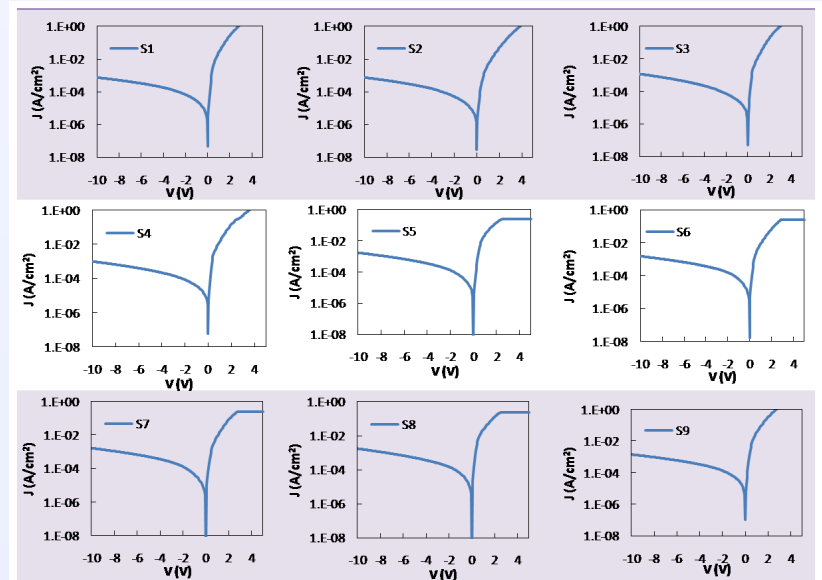
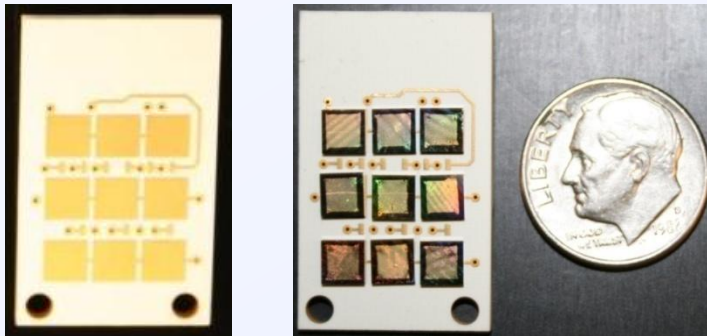

Scaling to Larger Area

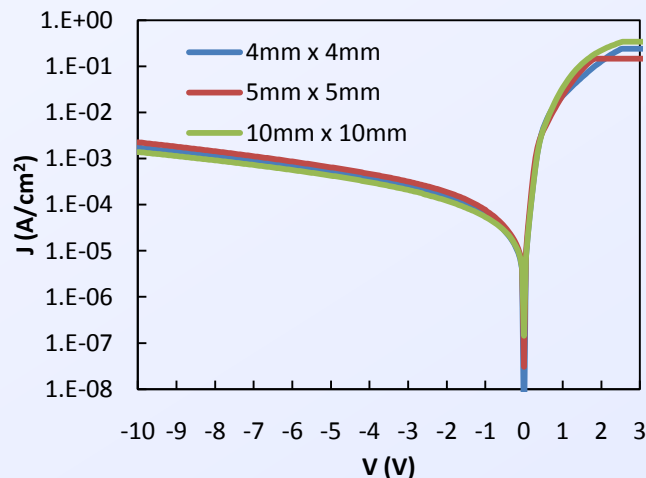

**Excellent uniformity
across 9, 4 mm x 4 mm detectors**
 $J_{\text{leak}}: 10^{-3} \text{ A/cm}^2$

Thermal neutron detection efficiencies measured at LLNL

Process for measuring thermal neutron efficiency:

- MCNP of source and lab for # of incident thermal neutrons
- $\text{Eff} = \text{Measured counts} / \text{simulated incident counts}$
- Measure “calibration” detector using poly moderated ^{252}Cf source
- Other detectors:
 - Compare to calibration detector to determine relative efficiency
- All detectors from “EPI-26” family 1” CVD system

Part #	Efficiency
EPI 26-1-1*	22
EPI 26-1-4	23
EPI 26-7-1	~20
EPI 26-6-3	16.4
EPI 26-7-2	16.1
EPI 26-7-3	19.2
EPI 26-7-4	17.8
EPI 26-1-2	~20
EPI 26-2-3	~20
EPI 26-2-4	~20

*Calibration detector

Packaged LLNL Pillar Detector



TO can
2 mm x 2 mm detectors

Characterization of 9 Element Detector Array

Measurements with
rack-mount electronics

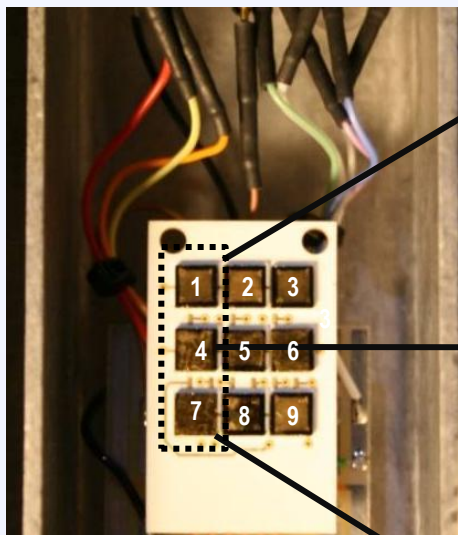

- Detector size 2 mm x 2 mm
- Moderated ^{252}Cf sources
- 1.5 m distance
- Detector unbiased
- Measurement time 3000 sec.
- Total counts Channels Σ 1-9 = 16k
- 14 counts/sec/cm²

Lawrence Livermore National Laboratory

Element 1

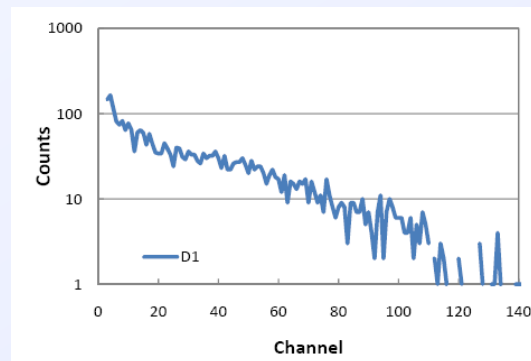
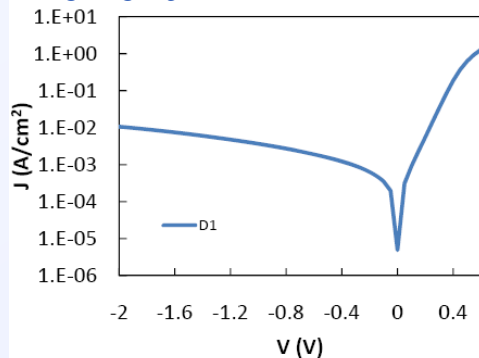

Element 4

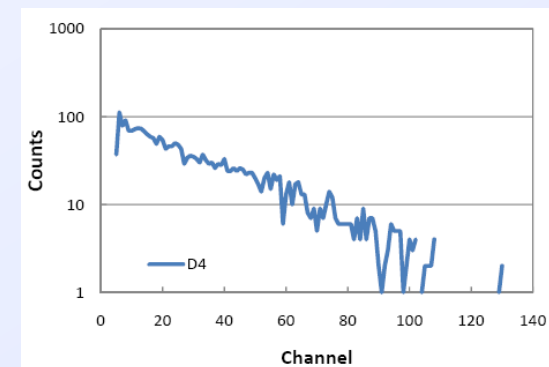
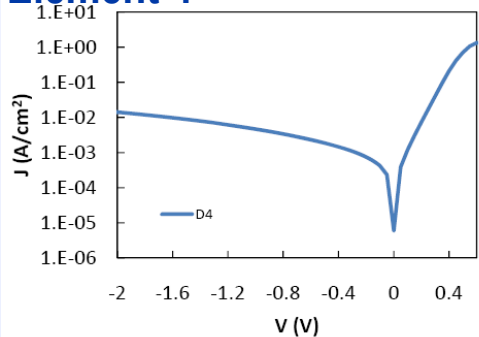

Element 7

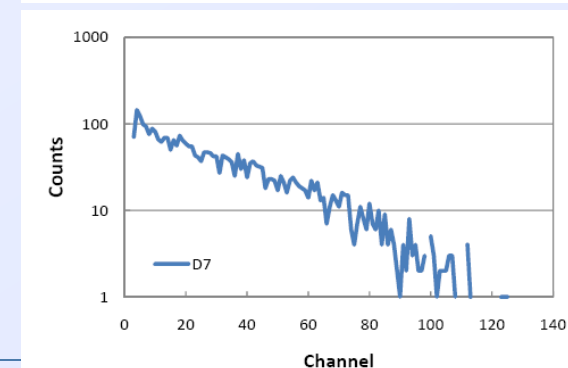
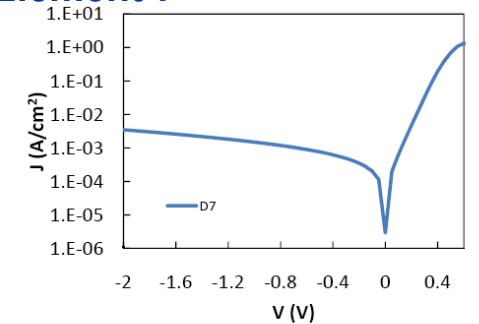

9 channel custom circuit with discrete components

- Custom design and layout with discrete COTS components
- Integrates 9 detectors with individual readout chain
 - Packaged individually
 - Or, on interposer board
- Readout chain includes:
 - Charge sensitive preamp
 - Shaping amplifier, 250 ns shaping time
 - Low level discriminator
 - Driver circuit for TTL output
 - LED display and driver circuits
 - Can readout either electron or hole signal

Individually packaged detectors

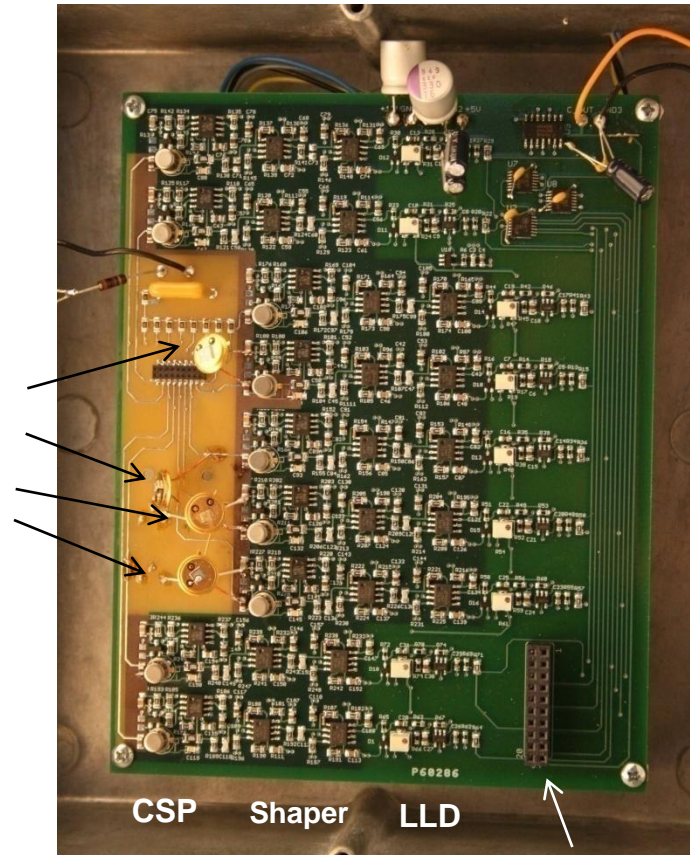

Output to LED display



Video: 3 detector channels

detector size 2 mm x 2 mm

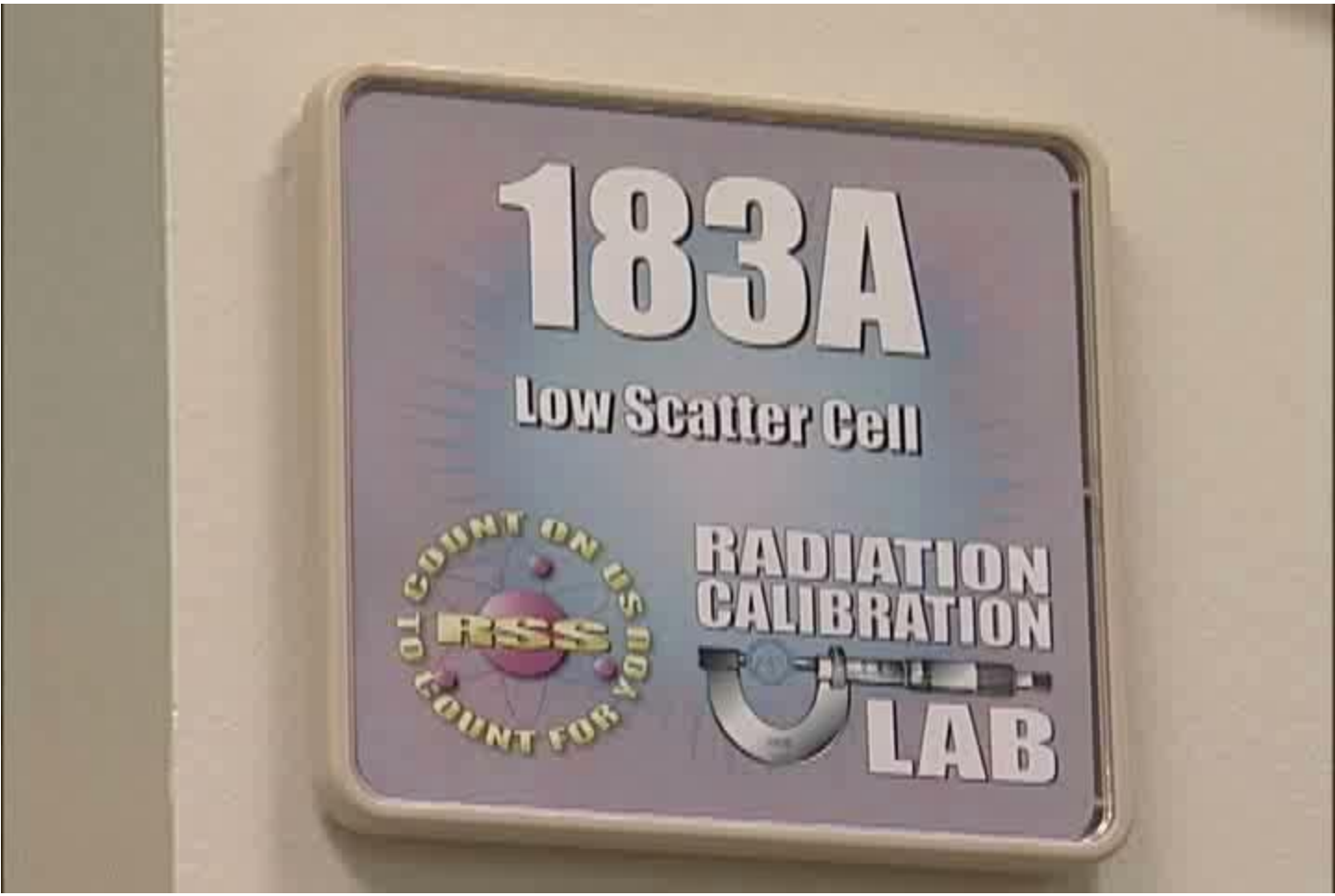

Read Out Design: ASIC

- Example for single channel, 8 channel was implemented

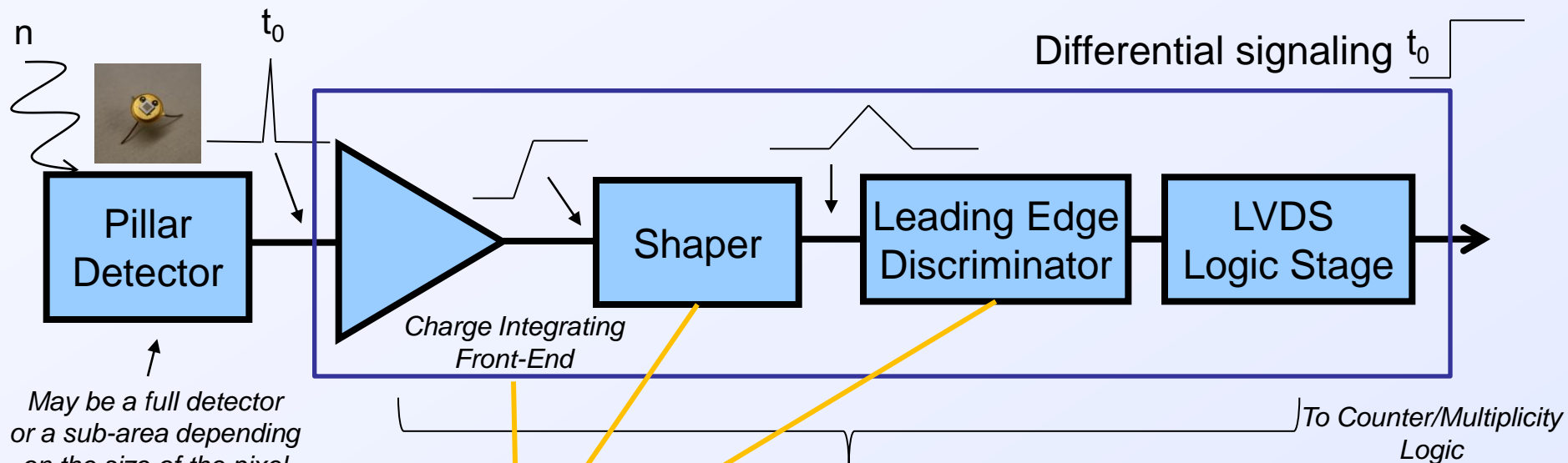

May be a full detector or a sub-area depending on the size of the pixel capacitance and leakage



Single ASIC Channel

ASIC
2.8 mm x 4.0 mm
8 Channels per ASIC
Mosis Foundry

20 ASICs received Dec. 2010



Silicon Detector for HLC: High radiation tolerance possible

*Silicon FZ Strip Detectors for High Luminosity Colliders

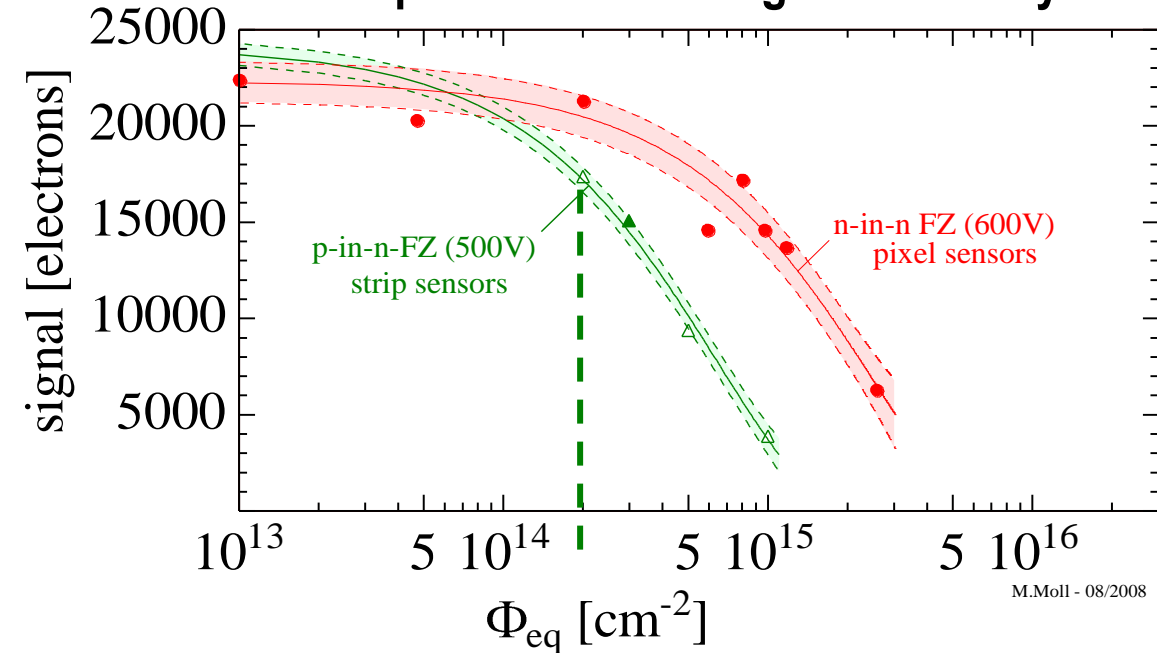

NIEL - nonionizing energy loss
IEL - ionizing energy loss

Radiation Damage to Sensors:

- **Bulk damage due to NIEL**
 - Change of effective doping concentration
 - Increase of leakage current
 - Increase of charge carrier trapping
- **Surface damage due to IEL**
(accumulation of positive charge in oxide & interface charges)

■ Determine if Pillar Detector has elevated damage due to:

- large surface area
- composite material structure

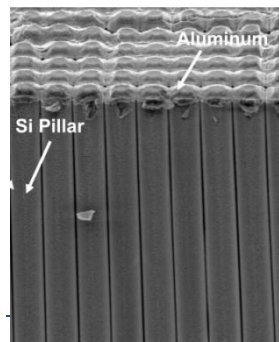

High fluence measurements: gamma

Test setup

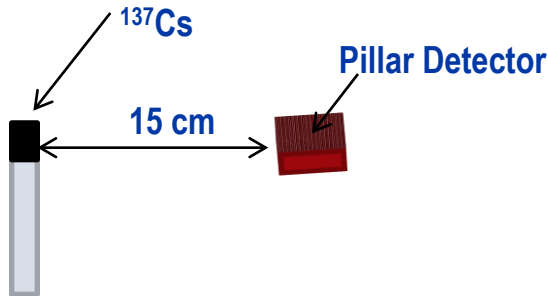

- Electrical measurements done before and after irradiation
- Time, 60ksec (16 hours)
- Gamma flux: 2.64×10^9 photons/($\text{cm}^2 \cdot \text{sec}$)
- Total gamma fluence delivered: 2.0×10^{14} photons/ cm^2
- Electrical properties of I-V, C-V and transient voltage decay remain same:

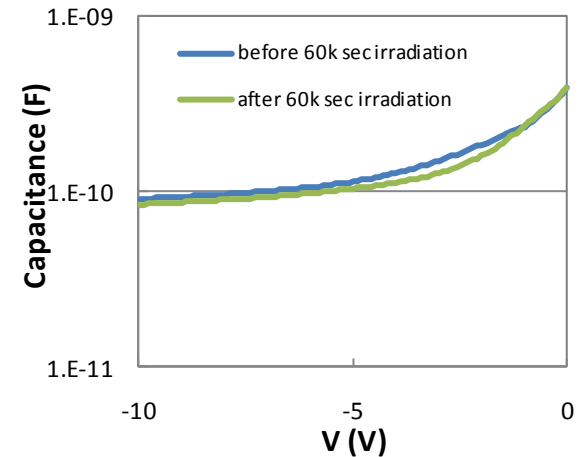
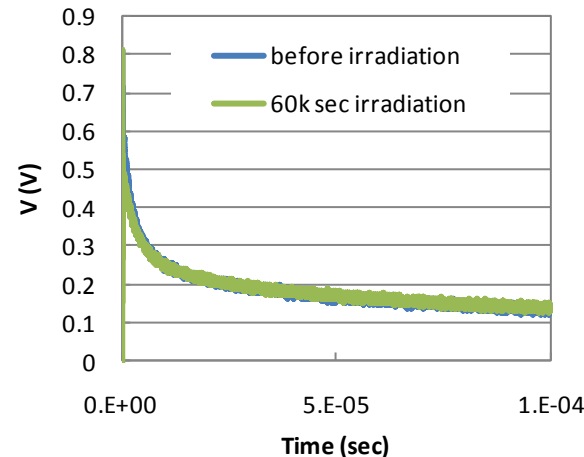
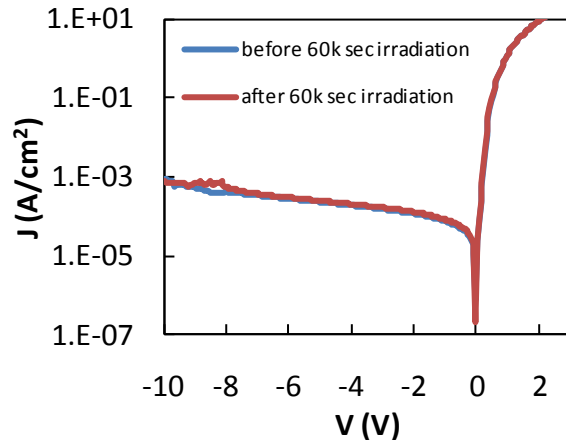

I-V remains the same

- No trapping centers introduced
- No damage in the depletion region

Transient voltage decay remains the same

- No change in effect lifetime: $\sim 1.0 \mu\text{s}$
- No damage in bulk or pillar sidewalls

C-V remains the same

- No change in voltage pulse for a certain amount of induced charges
- Neutron detection performance not degraded

High fluence measurements: fast neutron

Test setup

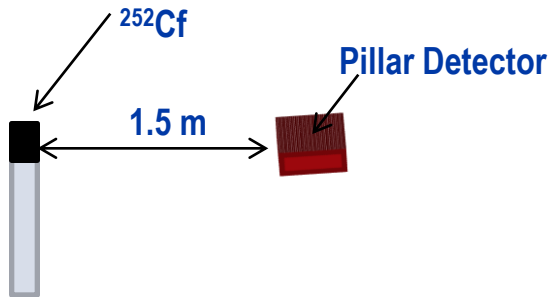

- Electrical measurements done before and after irradiation
- Time, 60ksec (16 hours)
- Neutron flux: 3.2×10^3 n/(cm²·sec)
- Total neutron fluence delivered: 1.9×10^8 n/cm²
- Electrical properties of I-V, C-V and transient voltage decay remain same

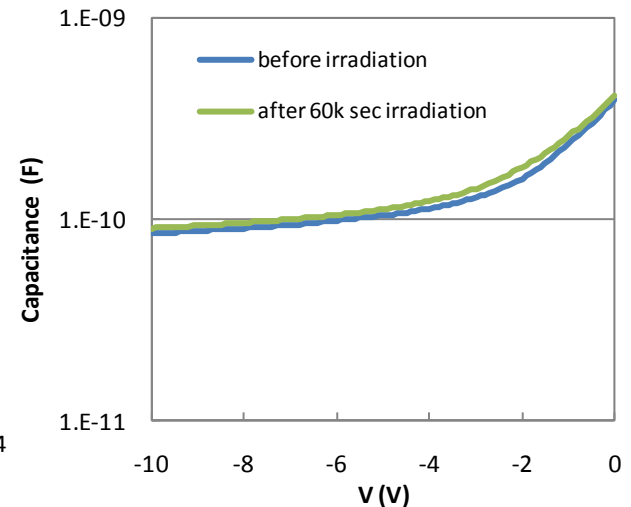
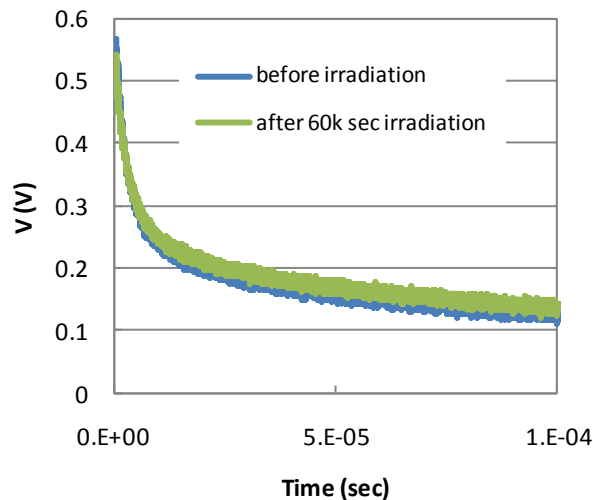
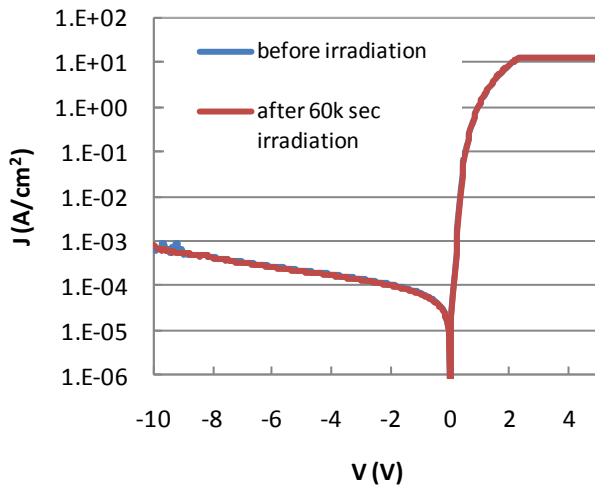

I-V remains the same

- No trapping centers introduced
- No damage in the depletion region

Transient voltage decay remains the same

- No change in effect lifetime: $\sim 1.0 \mu\text{s}$
- No damage in bulk or pillar sidewalls

C-V remains the same

- No change in voltage pulse for a certain amount of induced charges
- Neutron detection performance not degraded

High fluence measurements summary

Thermal neutron counts monitored before & after irradiation testing

Thermal Neutron Counts Set-up

- Moderated ^{252}Cf source 4×10^8 n/sec
 - 30 cm diameter D_2O covered with 1 mm Cd
- Time 60k sec (16 hours)
- 0.5 micro-sec shaping time
- Detector bias = 0V

Gamma and Neutron Radiation

Gamma (#/cm ² s)
10^9
Neutron (#/cm ² s)
10^3

No reduction in n counts

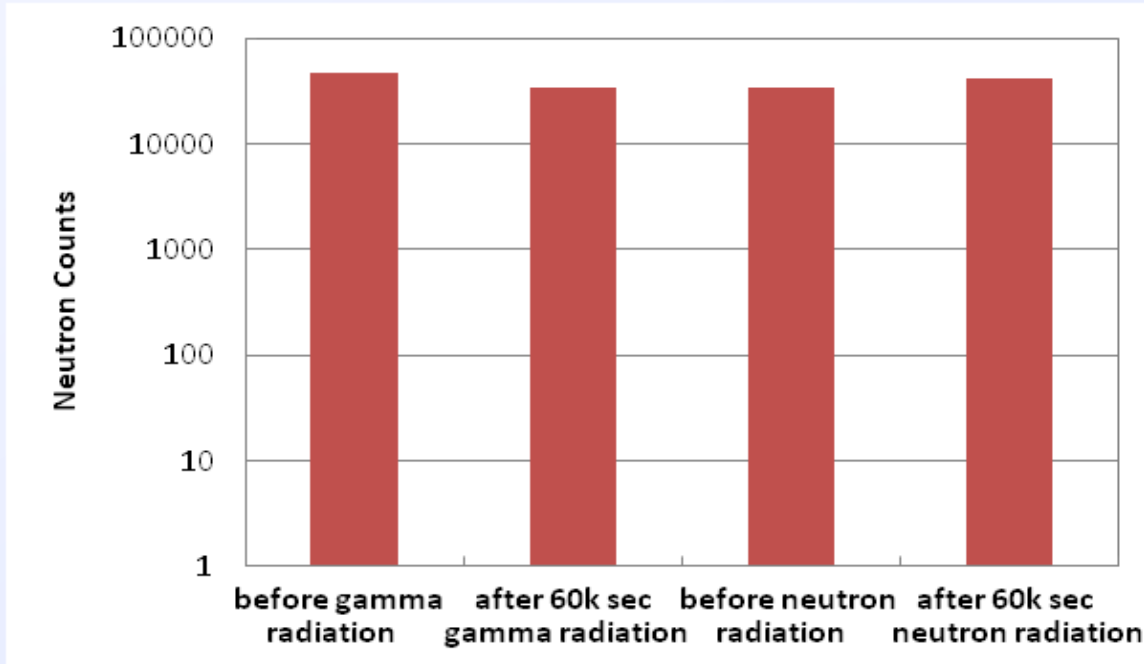

Measurement of He-3 detector for comparison with Pillars

- ^3He detector can be used for efficiency calibration
- He-3 detector used:
 - Cylindrical ^3He from LND, Inc.
 - Active volume
 - 1.55 cm diameter, 2.39 cm long
 - 4 Atm ^3He , 850V
 - Data sheet efficiency $\sim 30\%$ thermal neutrons
- Initial measurements performed
- Efficiency calculations underway

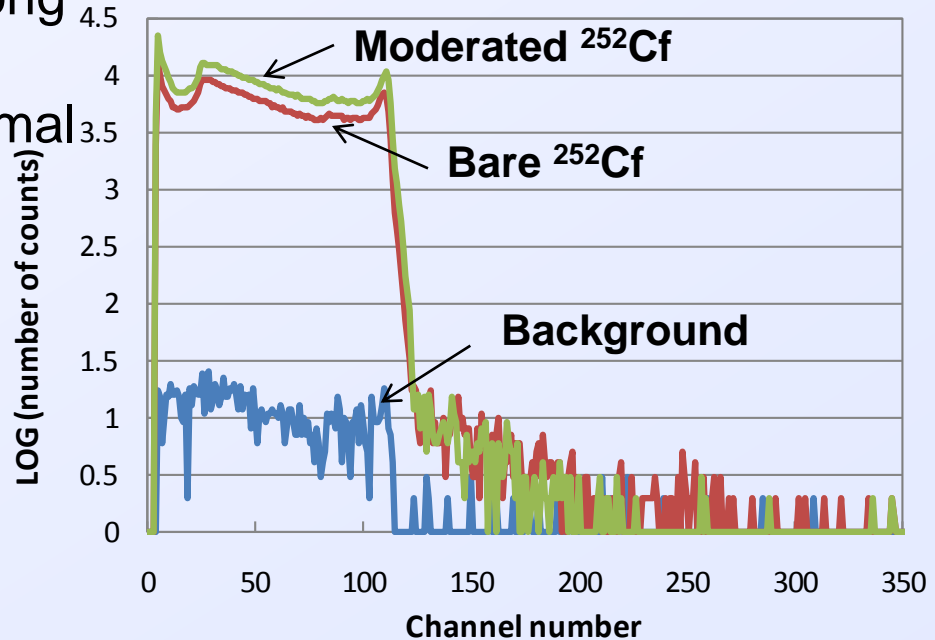
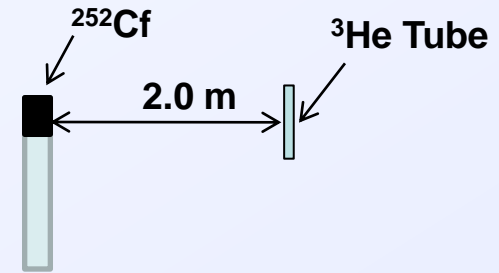

Conditions	Counts
No Source	1393
Bare ^{252}Cf	622413
Moderated* ^{252}Cf	887504

^3He vs Pillar Detector

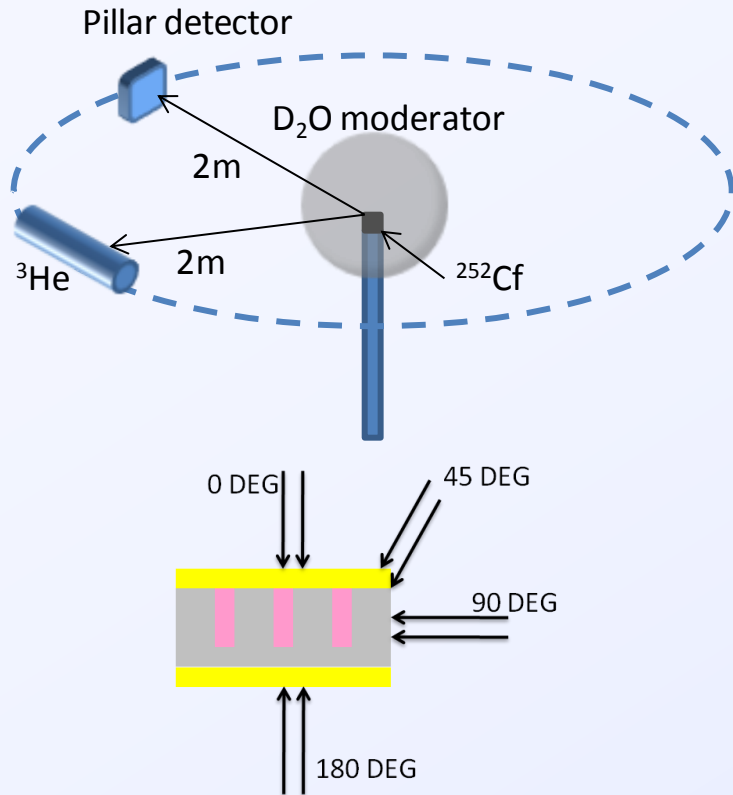

Detector	^3He tube* (LND-25177)	Pillar detector (EPI26-1-1)
Active dimensions (cm)	Diameter:1.55 Length:2.39	0.2 x 0.2
Operation voltage (V)	850	0
Total counts (1 hour)	886,111	3067
CPS/area (#/cm ² ·s)	66.44	21.30

*Gas pressure: 3040 torr

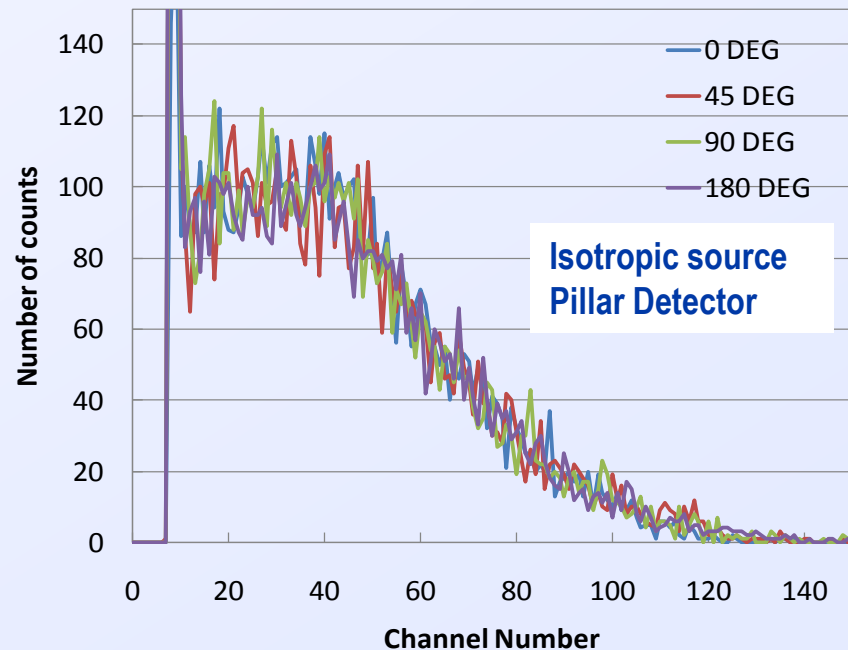

Isotropic source

No angular dependence (as shown in measurements)

Non-Isotropic source

Little streaming 4.6 ° solid angle to deflect out Si

Mapping Pillar Detector Over ³He Tube Form: Efficiency Comparison

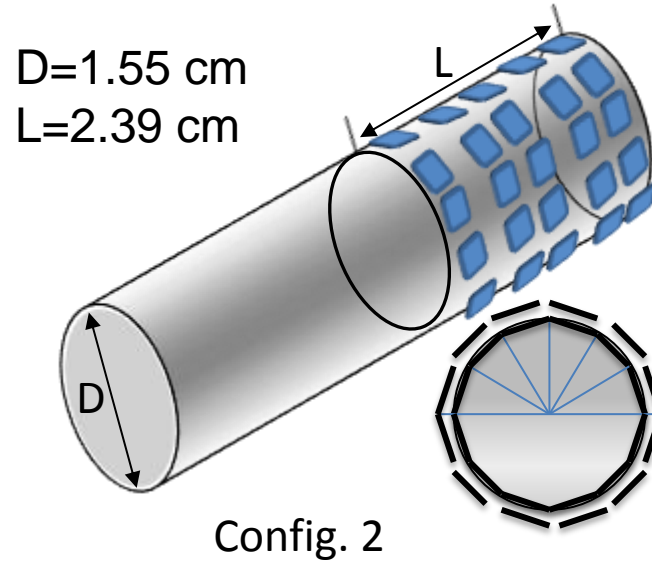
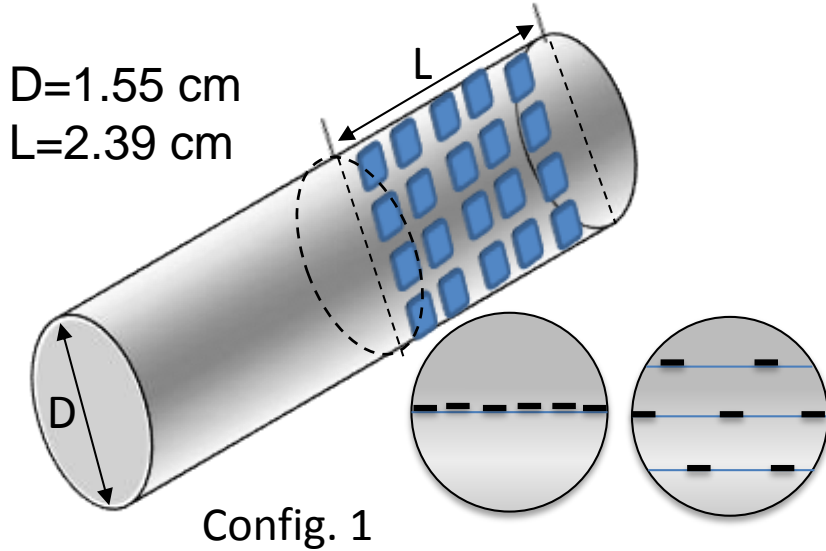

Comparison of ³He and pillar detector (**246.14 cps for ³He**)

Configurations		Pillar Efficiency	Number of detectors	Total counts per second	Sensitivity normalized to ³ He
1	Single side	22 %	7 x 11 (77)	65.45	0.27
	Single side	44 %	7 x 11 (77)	130.9	0.53
2	Single side	22 %	12 x 11 x 2 (264)	224.4	0.91
	Single side	44 %	12 x 11 x 2 (264)	449	1.82

Pillar efficiency can increase by lining multiple layers within the form factor

Summary

- Pillar based neutron detectors can be a ^3He replacement (small form factor applications)
- Ideal material system is Si (electron/hole collection) and ^{10}B (neutron conversion)
- High aspect ratio structures of $2\ \mu\text{m} \times 2\ \mu\text{m}$ pillars, with a $4\ \mu\text{m}$ pitch and scaled to $\sim 50\ \mu\text{m}$ can achieve 50 % thermal neutron detection efficiency, currently at 20 %
- 8-channel ASIC read-out integration underway
- Scaling for efficiency and area

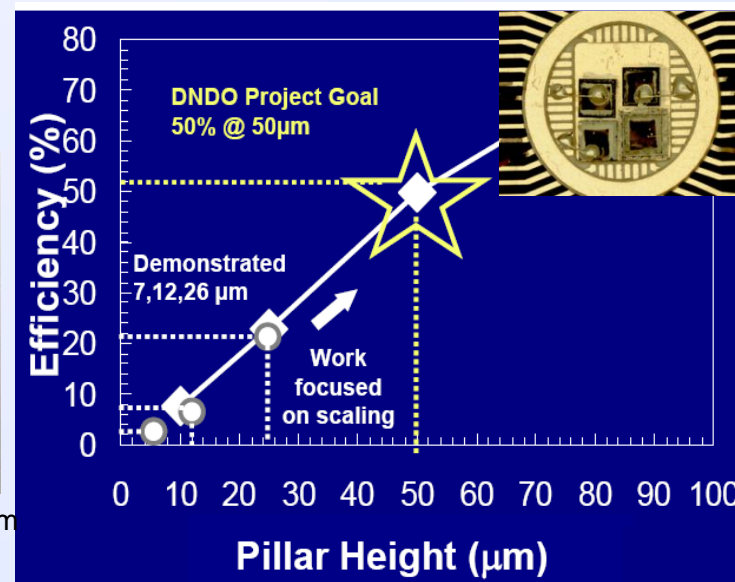
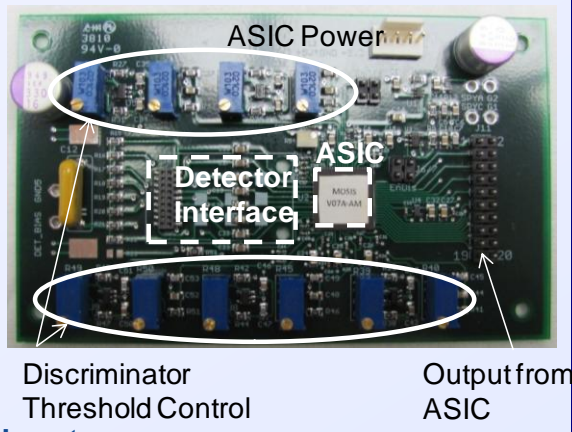
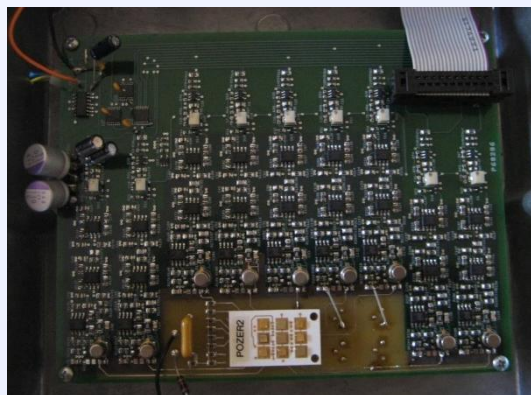

Acknowledgement

- DHS DNDO Program Manager:
 - » Dr. Alan Janos
- LLNL Radiation Detector Materials PEL:
 - » Dr. Steve Payne
- LLNL Technician Staff:
 - » Cathy Reinhardt
 - » Tim Graff
 - » Marianne Ammondolia